



THE DATASHEET OF SIAERO+-EVB



Aero™/Aero+ GSM/GPRS Transceiver Chipsets

**INTEGRATED TRANSCEIVERS FOR MULTI-BAND
GSM/GPRS WIRELESS COMMUNICATIONS**

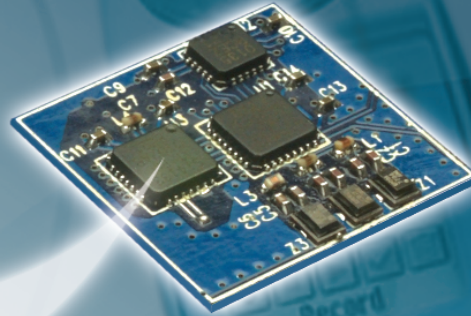

FEATURES

- Complete multi-band GSM cellular radio front-end using 100% CMOS RF technology
 - GSM 850
 - E-GSM 900
 - DCS 1800
 - PCS 1900
- Best-in-class performance
- Unparalleled integration
 - 50% less board area
 - 80% fewer components
- Low-IF receiver
 - Dual or triple band LNA
 - Image-reject down-converter
 - High performance A/D converter
- Universal analog baseband interface
 - Digital channel select filter
 - Digital programmable gain control
- Offset PLL transmitter
 - High precision I/Q up-converter
 - Integrated transmit VCO and loop filter
- Proven frequency synthesizer technology
 - Integrated RF and IF VCOs
- Integrated reference oscillator (DCXO)
- GPRS class 12 compliant
- 2.7 to 3.0 V operation
- Low profile packages
 - Si4200: 5 x 5 mm MLP32
 - Si4201: 4 x 4 mm MLP20
 - Si4133T/34T: 5 x 5 mm MLP28/MLP32

APPLICATIONS

- Multi-band GSM cellular handsets
- GPRS voice and data terminals

PRODUCT DESCRIPTION

The Aero transceiver is the industry's first 100% CMOS RF front-end for multi-band GSM digital cellular handsets and wireless data modems. The Aero's highly-integrated architecture eliminates the IF SAW filter, low noise amplifiers (LNAs) for three bands, transmit and RF voltage-controlled oscillator (VCO) modules, and more than 60 other discrete components found in conventional GSM handsets to deliver smaller, more cost effective GSM solutions that are easier to design and manufacture.

The receive section uses a digital low-IF architecture which avoids the difficulties associated with direct conversion receivers while lowering cost and reducing complexity. The universal analog baseband interface is compatible with any baseband subsystem. The transmit section uses an offset phase-locked loop (PLL) with a fully integrated transmit VCO. The frequency synthesizer takes advantage of Silicon Labs' proven synthesizer technology to integrate RF and IF VCOs, varactors and loop filters. The Aero+ transceiver integrates a digitally controlled crystal oscillator (DCXO) to eliminate expensive and bulky VC-TCXO modules.

AERO+ TRANSCEIVER BLOCK DIAGRAM

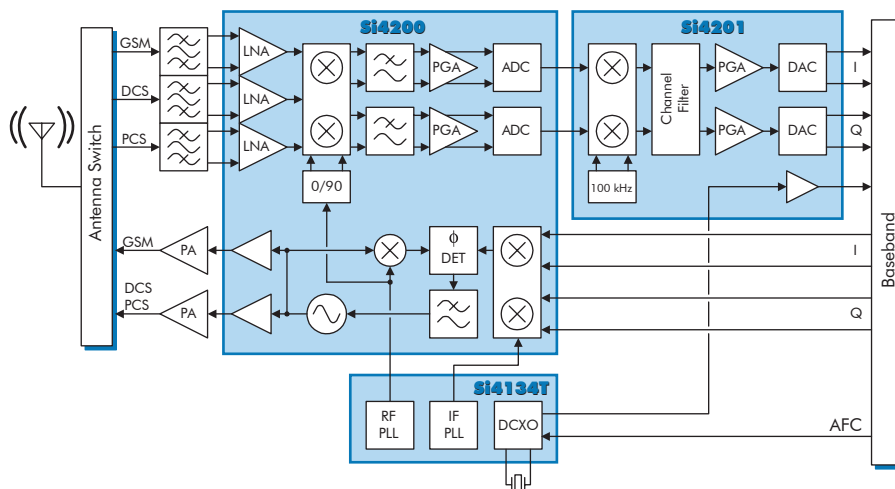

PRODUCT BRIEF

SILICON LABORATORIES'

AERO TRANSCEIVER:

RAISING CMOS

TO THE POWER OF RF



SILICON LABORATORIES

**INTEGRATED. CMOS.
UNIVERSAL. INNOVATIVE.**

Unparalleled Integration:

The Aero transceiver's innovative architecture eliminates the IF SAW filter, transmit and RF VCO modules and more than 60 other discrete components found in conventional GSM handset designs. This level of integration is an enabling force in lowering the cost, simplifying the design and manufacturing, and shrinking the form factor of the RF circuitry in next-generation GSM voice and data terminals.

100% CMOS Technology:

While conventional solutions use BiCMOS or other bipolar process technologies, the Aero chipset is the industry's first cellular transceiver to be implemented in a 100% CMOS process. This brings the dramatic cost savings and extensive manufacturing capacity of CMOS to the GSM market.

Universal Baseband Interface:

A software-programmable baseband interface enables the Aero transceiver to operate with any baseband subsystem. This programmability gives the handset designer the ability to use the latest RF technology without redesigning the baseband portion of the phone.

Digital Low-IF Receiver:

The Aero transceiver uses a patented digital low-IF receive architecture that avoids the difficult problems associated with direct conversion approaches while lowering cost, reducing complexity and ensuring consistent part-to-part operation.

50% Area Reduction / 80% Fewer Components

Aero/Aero+ Transceiver

Actual size shown

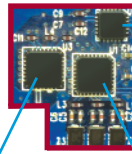

Si4201 Universal Baseband Interface

- 4 x 4 mm MLP20
- Software programmable to interface to any baseband subsystem

Si4133T/34T RF Synthesizer

- Si4133T (Aero): 5 x 5 mm MLP28
- Si4134T (Aero+): 5 x 5 mm MLP32
- Uses Silicon Labs' proven RF synthesizer technology
- Fastest settling times using a stable integer-N architecture
- Integrated DCXO (Aero+)

Si4200 Transceiver

- 5 x 5 mm MLP32
- Integrates the entire transmit and receive paths including the LNAs and transmit VCO

Alternate Technology

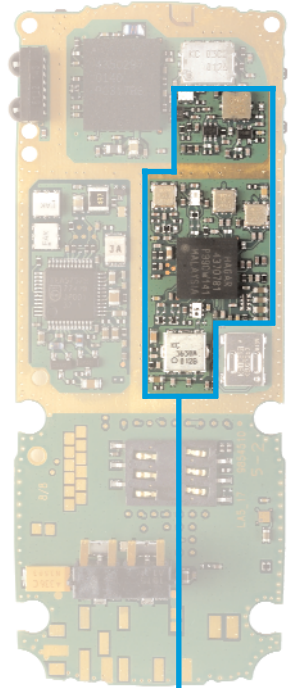

RF Subsection

TYPICAL SIZE COMPARISON			
	Total Area	Modules	Components
Silicon Laboratories' Aero+	2.4 cm²	0	20
Conventional RF Front End	5 cm²	2	80



CONTACT INFORMATION



SILICON LABORATORIES

Silicon Laboratories Inc.
4635 Boston Lane • Austin, TX 78735
Toll Free: 1(877)444-3032
Email: Aeroinfo@silabs.com
Web site: www.silabs.com

*"Raising CMOS to the Power of RF," Aero, Silicon Laboratories and the Silicon Laboratories logo are trademarks of Silicon Laboratories Inc.
CCW, 5,000, August 02, Rev A*

ORDERING INFORMATION

Product

- Si4200-BM
- Si4200DB-BM
- Si4133T-BM
- Si4134T-BM
- Si4201-BM

Description

- Tri-band Transceiver—(GSM 850 or GSM 900)/DCS 1800/PCS 1900
- Dual-band Transceiver—GSM 900/DCS 1800 or GSM 850/PCS 1900
- Dual RF Synthesizer
- Dual RF Synthesizer with DCXO (Aero+)
- Universal Baseband Interface

Data Sheets



- Si4200-DS Aero GSM/GPRS Transceiver Data Sheet
- Aero+-DS Aero+ GSM/GPRS Transceiver Data Sheet
- Aero-EVB-DS Aero Transceiver Evaluation Board Data Sheet

Evaluation Boards

- Aero-EVB Aero Evaluation Board
- SiAero+-EVB Aero+ Evaluation Board

Looking for pricing, stock, or lifecycle information?

Click below to explore more details on WIN SOURCE:

-  [View SIAERO+-EVB](#) on WIN SOURCE
-  [Silicon Labs](#) Information

Optimize Your Supply Chain with WIN SOURCE Solutions

-  Global Sourcing Solution
-  Obsolete Management
-  Cost Control Management
-  Shortage Management
-  Alternative Solution
-  Excess Inventory Management