

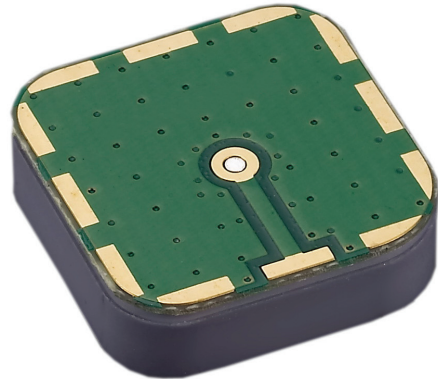

THE DATASHEET OF SGPD.15B

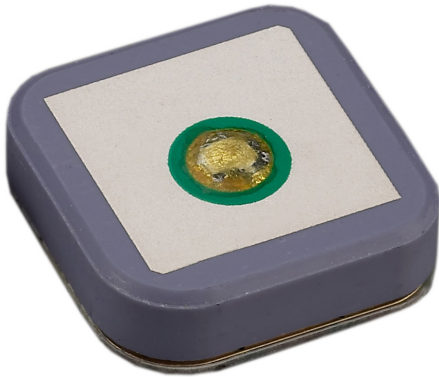



SGP.15a

Specification

Part No.	SGP.1575.15.4.A.02
Product Name	GPS SMT Patch Antenna
Features	15mm*15mm*4.5mm 1575MHz Centre Frequency Patent Pending RoHS Compliant

1. Introduction

This ceramic GPS patch antenna is based on smart **XtremeGain™** technology. It is mounted via SMT process and has been selected as optimal solution for the 45x45mm ground plane.

2. Specification

Original Patch Specification tested on 45mm ground plane

Parameter	Specification	Notes
Range of Receiving Frequency	1575.42 ± 1.023MHz	
Center Frequency	1575.42 ± 3MHz	With 45*45mm ground plane
Bandwidth	6MHz min	
Return Loss	≤-10 dB	
VSWR	1.5 max	
Gain at Zenith	+1.0 dBic typ.	
Axial Ratio	3.0 dB max	
Polarization	RHCP	
Impedance	50 Ohms	
Frequency Temperature Coefficient (τf)	0 ± 20ppm / °C	-40°C to +85°C
Operating Temperature	-40°C to +85°C	

****Changes in user groundplane and environment will offset centre frequency**

3. Electrical Specifications

3.1 Return Loss, SWR, Impedance, measured on the test fixture

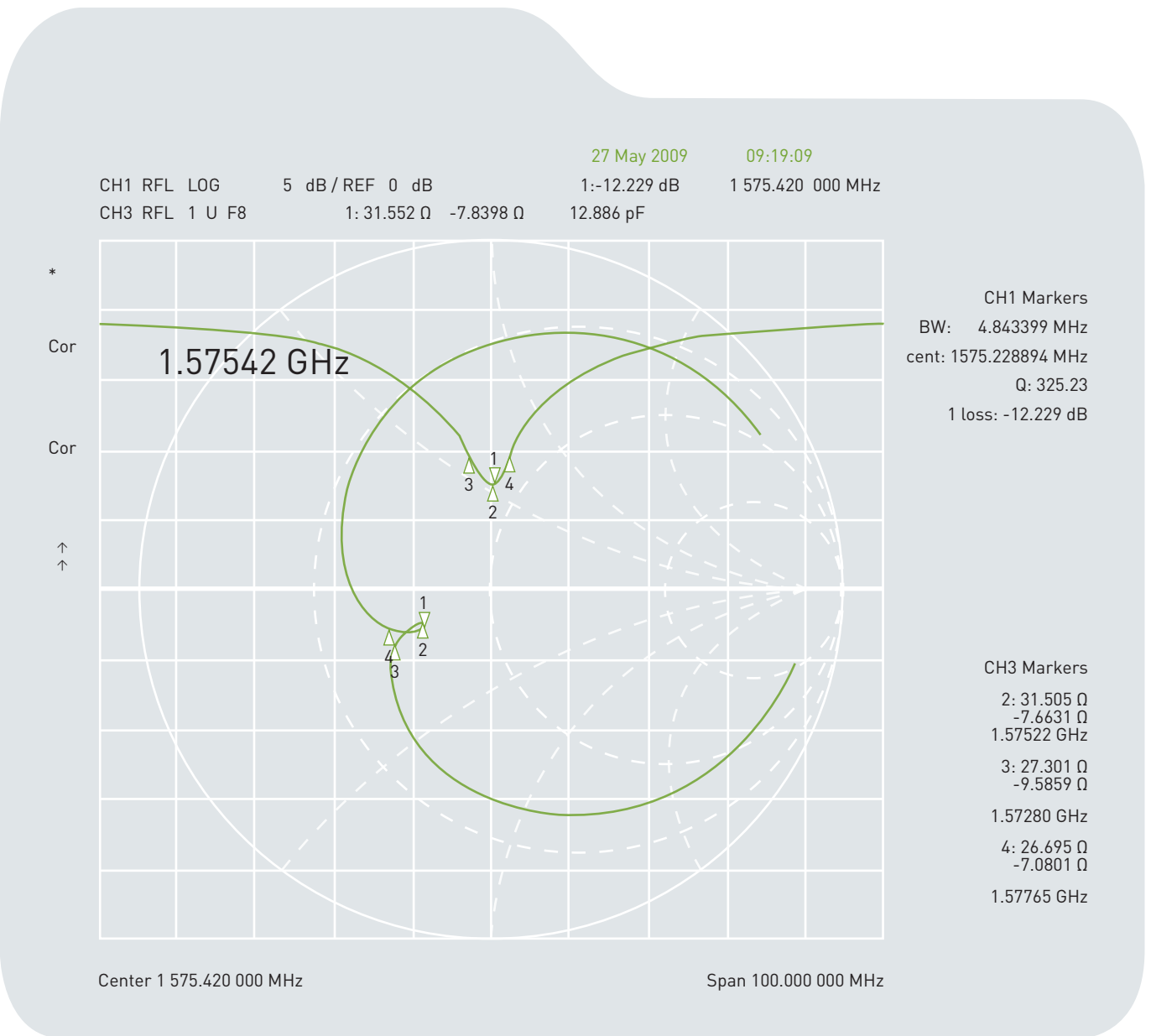

4. Mechanical Specifications

4.1 Dimensions and Drawing

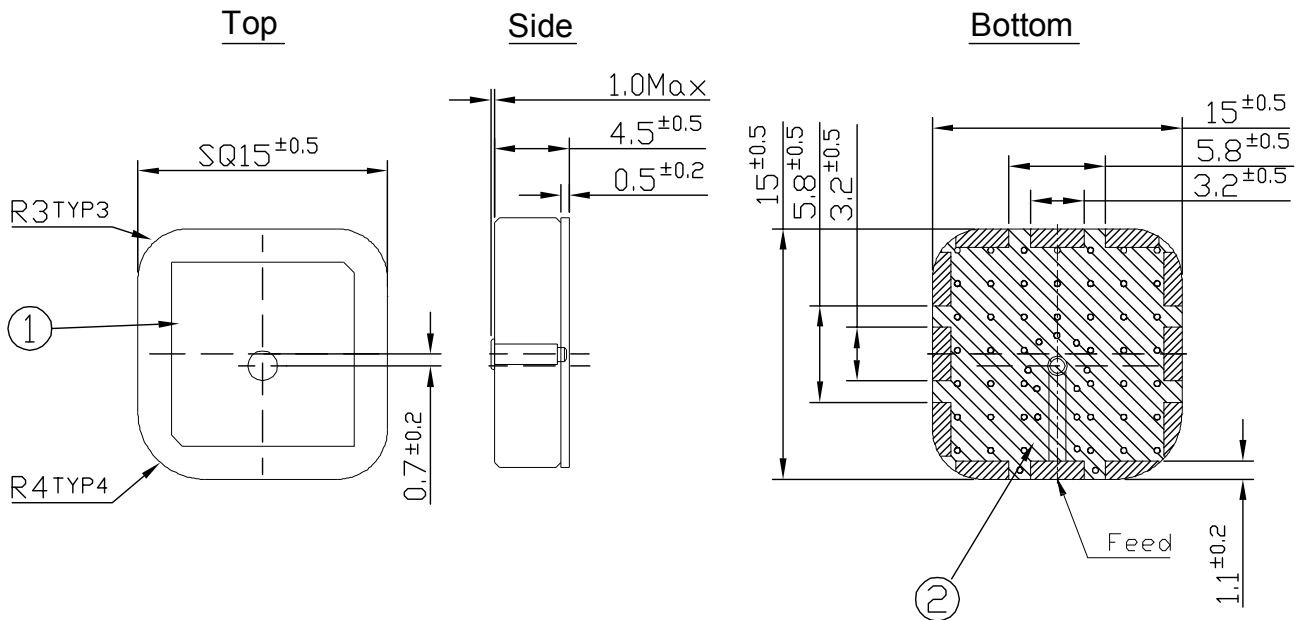

NOTE:

1. Solder mask.
2. Area to be soldered.
3. Clearance area.
4. Dimension of 50 Ohm CPW dependent on individual board.
5. Must be soldered to complete antenna feed connection.

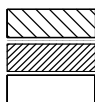

	Name	Part No.	Material	Finish	Quantity
1	SGP.15 Patch 15x15x4	SGP.15	Ceramic	Clear	1
2	SGP.15 PCB		FR4 0.5t	Green	1

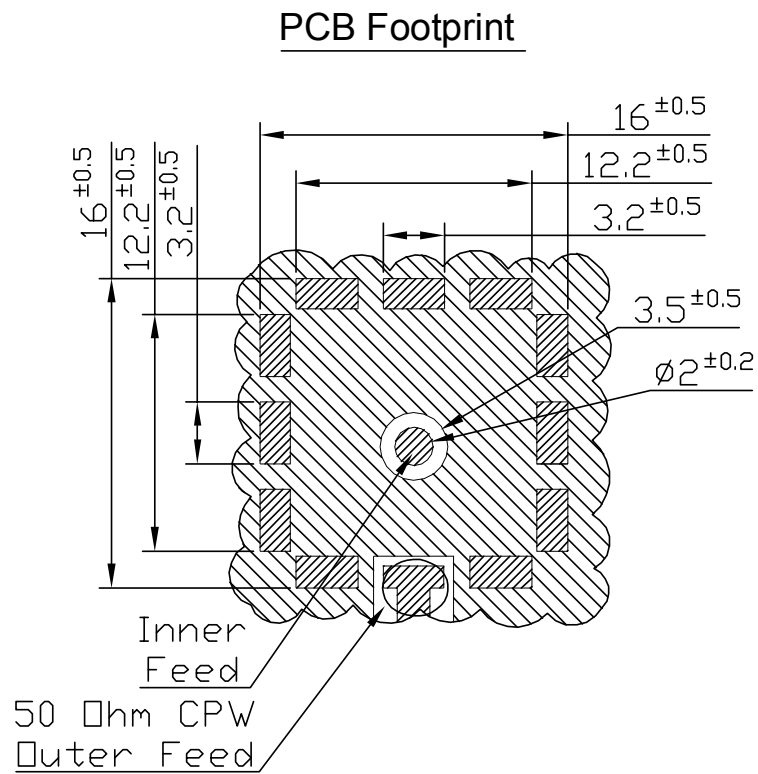

4.2 Antenna footprint

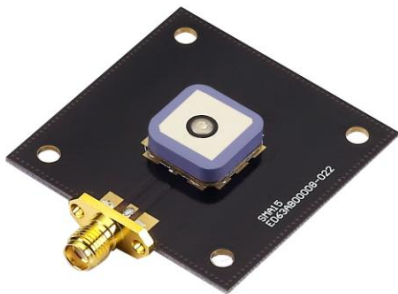
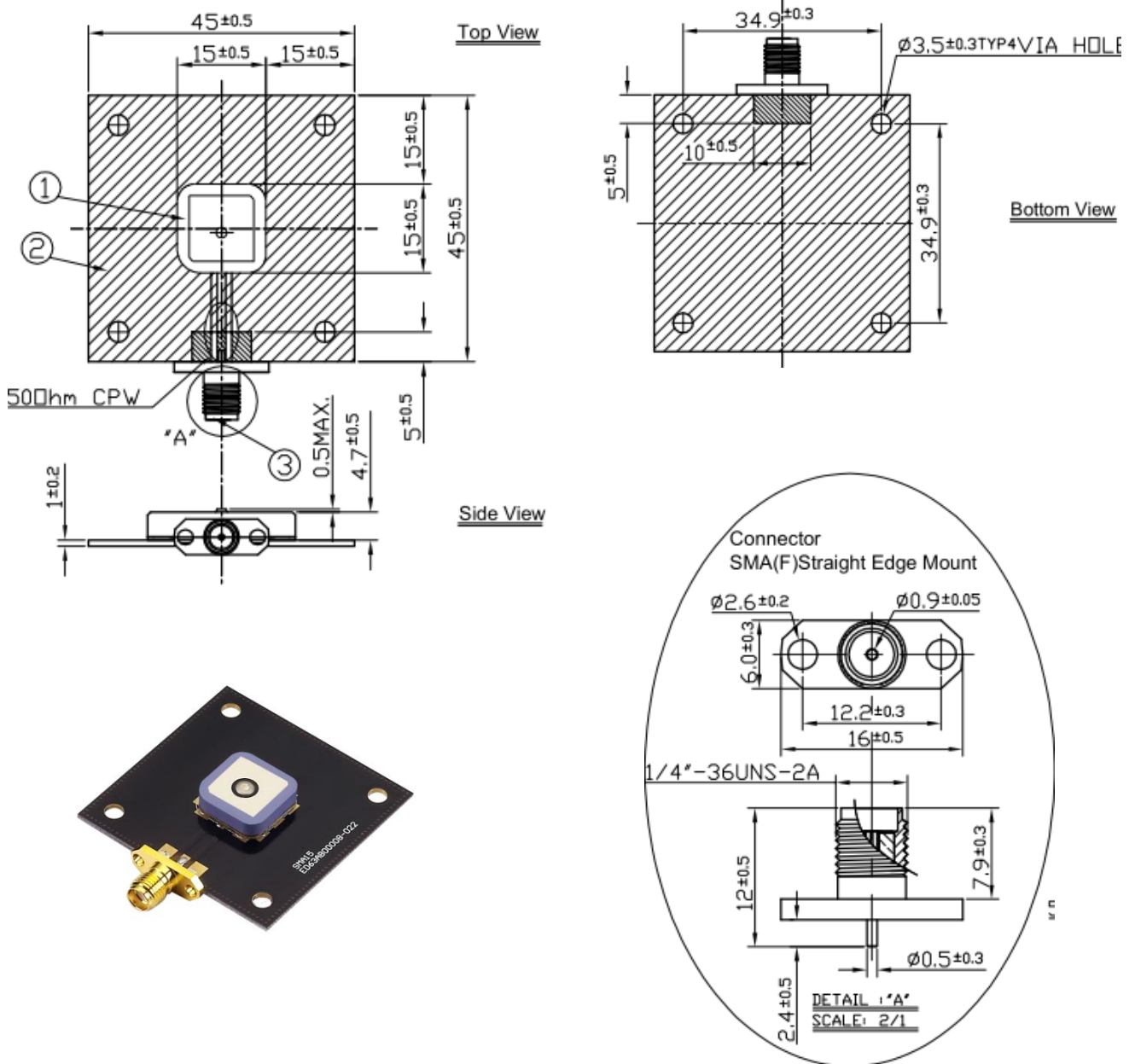

4.3 Test Jig and Dimension



NOTE:

- 1. Solder Mask (Black) 
- 2. Solder Area 

Name	P/N	Material	Finish	Qty
1 SGP.15 Patch 15x15x4	SGP.15A	Ceramic	Clear	1
2 FR4 PCB		FR4 1t	Black	1
3 SMA(F)Straight Edge Mount	SMA.F.ST.JACK.PANELM.2H.CM	Brass	Gold	1

4.4 Test Fixture set up and measurements

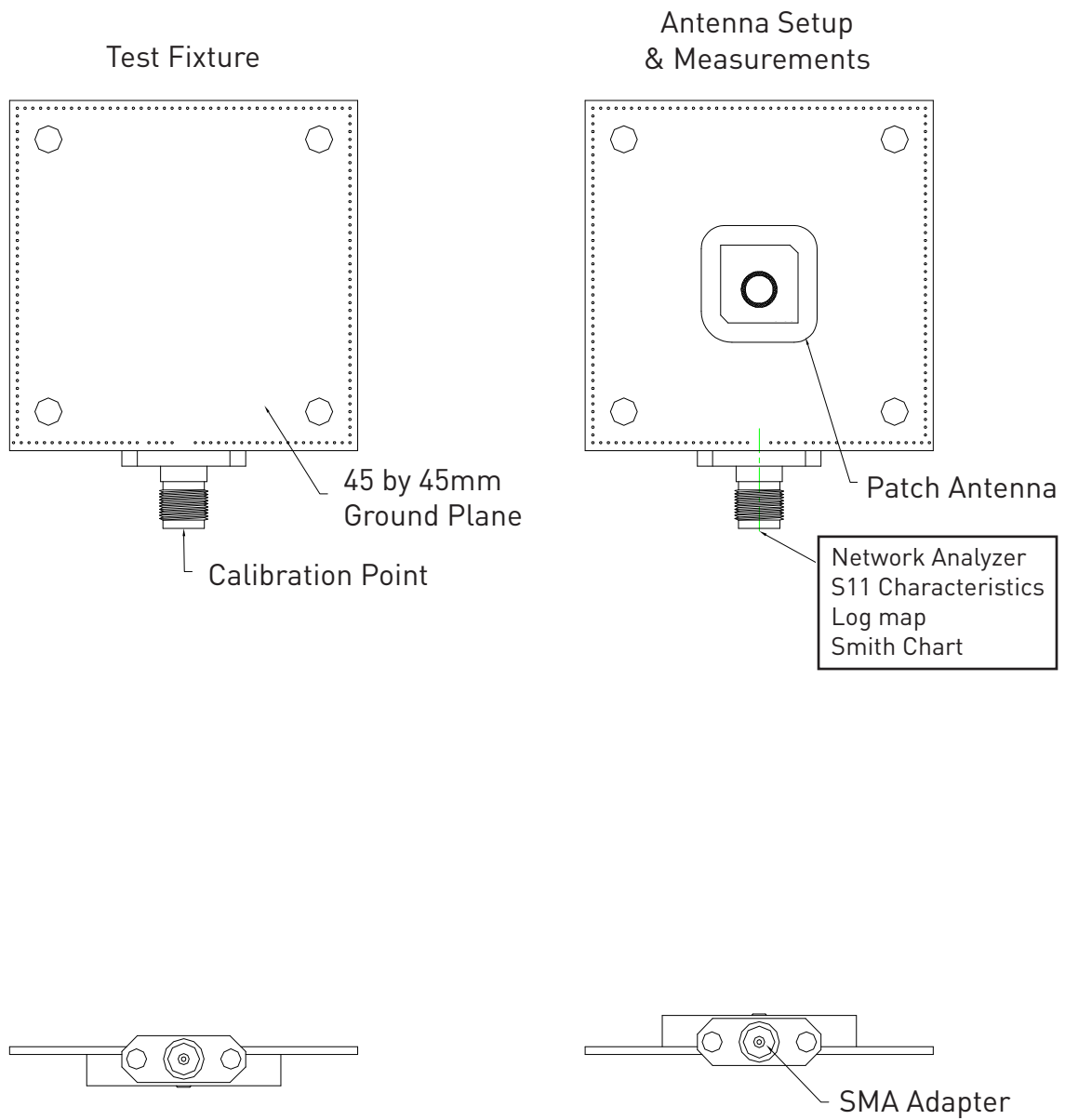

5. Antenna Recommended Soldering Conditions

5.1 Flux, Solder

- Use rosin-based flux. Don't use highly acidic flux with halide content exceeding 0.2wt%(chlorine conversion value).
- Use Sn solder.

5.2 Reflow Soldering Conditions

- Pre-heating should be in such a way that the temperature difference between solder and product surface is limited to 150°C max. Cooling into solvent after soldering also should be in such a way that temperature difference is limited to 100°C max. Unwrought pre-heating may cause cracks on the product, resulting in the deterioration of products quality.

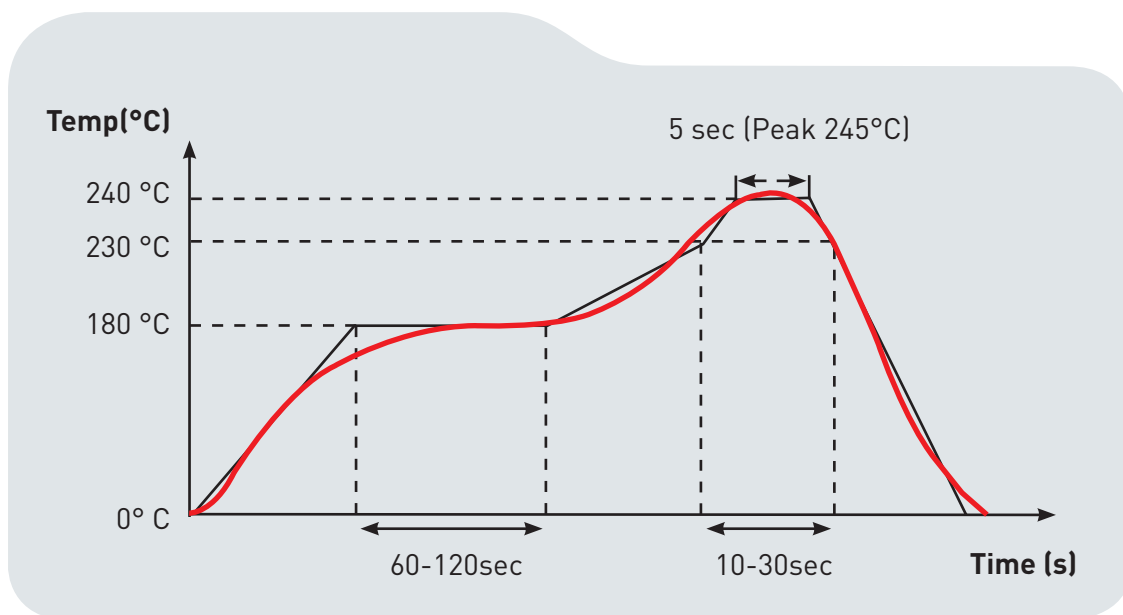

5.3 Reflow with Soldering Iron

- The following conditions must be strictly followed when using a soldering iron.

Pre-heating	150°, 1 min
Tip temperature	290° max
Soldering iron output	30w max
Soldering time	3 second max

Looking for pricing, stock, or lifecycle information?

Click below to explore more details on WIN SOURCE:

- ⊖ [View SGPD.15B](#) on WIN SOURCE
- ⊖ [Taoglas Limited](#) Information

Optimize Your Supply Chain with WIN SOURCE Solutions

- ✓ Global Sourcing Solution
- ✓ Obsolete Management
- ✓ Cost Control Management
- ✓ Shortage Management
- ✓ Alternative Solution
- ✓ Excess Inventory Management