



THE DATASHEET OF SMARTRF06EBK



SmartRF06 Evaluation Board (EVM)

User's Guide



Literature Number: SWRU321B
May 2012–Revised March 2017

1	Introduction	5
2	About This Manual	5
2.1	Acronyms.....	6
3	Getting Started	6
3.1	Installing SmartRF Studio and USB Drivers	6
4	Using the SmartRF06 Evaluation Board	9
4.1	Absolute Maximum Ratings	10
5	SmartRF06 Evaluation Board Overview	11
5.1	XDS100v3 Emulator.....	13
5.2	Power Sources.....	13
5.3	Power Domains	15
5.4	LCD.....	17
5.5	Micro SD Card Slot	17
5.6	Accelerometer	18
5.7	Ambient Light Sensor	18
5.8	Buttons	19
5.9	LEDs.....	19
5.10	EVM Connectors.....	19
5.11	Breakout Headers and Jumpers	22
5.12	Current Measurement	25
6	Debugging an External Target Using SmartRF06EB	27
6.1	20-Pin ARM JTAG Header	28
6.2	10-Pin ARM Cortex Debug Header	28
6.3	Custom Strapping.....	29
7	Frequently Asked Questions	30
8	References	30
Appendix A	Schematics	31
A.1	SmartRF06EB 1.2.1.....	31
	Revision History	37

List of Figures

1	Driver Install: Update Driver	7
2	Driver Install: Specify Path to FTDI Drivers	7
3	Driver Install: VCP Loaded	8
4	Driver Install: Drivers Successfully Installed	8
5	SmartRF06EB (rev. 1.2.1) With EVM Connected	9
6	SmartRF06EB Architecture	11
7	SmartRF06EB Revision 1.2.1 Front Side	12
8	SmartRF06EB Revision 1.2.1 Reverse Side	12
9	Jumper Mounted on J5 to Enable the UART Back Channel	13
10	Main Power Switch (P501)	14
11	Source Selection Switch (P502)	14
12	SmartRF06EB Power Selection Switch (P502) in “USB” Position	14
13	SmartRF06EB Power Source Selection Switch (P502) in “BAT” Position	14
14	SmartRF06EB External Power Supply Header (J501)	15
15	Power Domain Overview of SmartRF06EB	15
16	Mount a Jumper on J502 to Bypass EVM Domain Voltage Regulator	16
17	Simplified Schematic of Ambient Light Sensor Setup	18
18	SmartRF06EB EVM Connectors RF1 and RF2	19
19	SmartRF06EB I/O Breakout Overview	22
20	XDS100v3 Emulator Bypass Header (P408)	24
21	20-Pin ARM JTAG Header (P409)	24
22	10-Pin ARM Cortex Debug Header (P410)	25
23	Measuring Current Consumption Using Jumper J503	26
24	Measuring Current Consumption Using Jumper J503	26
25	Simplified Connection Diagram for Different Debugging Scenarios	27
26	Debugging External Target Using SmartRF06EB	28
27	ARM JTAG Header (P409) With Strapping to Debug External Target	29
28	SmartRF06EB - Top Level	31
29	SmartRF06EB - XDS100v3 - FPGA	32
30	SmartRF06EB - XDS100v3 - FTDI	33
31	SmartRF06EB - EVM Interfaces/Level Shifters	34
32	SmartRF06EB - Power Supply	35
33	SmartRF06EB - High Voltage Peripheral	36
34	SmartRF06EB - Low Voltage Peripherals	36

List of Tables

1	SmartRF06EB Features	5
2	Acronyms	6
3	Supply Voltage: Recommended Operating Conditions and Absolute Maximum Ratings	10
4	Temperature: Recommended Operating Conditions and Storage Temperatures	10
5	UART Back Channel Signal Connections.....	13
6	Power Domain Overview of SmartRF06EB.....	16
7	LCD Signal Connections	17
8	Micro SD Card Signal Connections.....	17
9	Accelerometer Signal Connections	18
10	Ambient Light Sensor Signal Connections.....	18
11	Button Signal Connections.....	19
12	General Purpose LED Signal Connections	19
13	EVM connector RF1 Pin Out	20
14	EVM Connector RF2 Pin Out	21
15	SmartRF06EB I/O Breakout Overview	23
16	20-Pin ARM JTAG Header Pin-Out (P409).....	24
17	10-Pin ARM Cortex Debug Header Pin-Out (P410)	25
18	Debugging External Target: Minimum Strapping (cJTAG support).....	29
19	Debugging External Target: Optional Strapping	29

SmartRF06 Evaluation Board (EVM)

1 Introduction

The SmartRF06 Evaluation Board (SmartRF06EB or simply EB) is the motherboard in development kits for Low Power RF ARM® Cortex®-M based System-on-Chips from Texas Instruments. The board has a wide range of features, shown in [Table 1](#).

Table 1. SmartRF06EB Features

Component	Description
TI XDS100v3 emulator	cJTAG and JTAG emulator for easy programming and debugging of SoCs on Evaluation Modules (EVM) or external targets.
High-speed USB 2.0 interface	Easy plug and play access to full SoC control using SmartRF™ Studio PC software. Integrated serial port over USB enables communication between the SoC via the UART back channel.
64x128 pixels serial LCD	Big LCD display for demo use and user interface development.
LEDs	Four general purpose LEDs for demo use or debugging.
Micro SD card slot	External flash for extra storage, over-the-air upgrades and more.
Buttons	Five push-buttons for demo use and user interfacing.
Accelerometer	Three-axis highly configurable digital accelerometer for application development and demo use.
Light sensor	Ambient light sensor for application development and demo use.
Breakout pins	Easy access to SoC GPIO pins for quick and easy debugging.

2 About This Manual

This manual contains reference information about the SmartRF06EB.

[Section 3](#) will give a quick introduction on how to get started with the SmartRF06EB. It describes how to install the SmartRF Studio software to get the required USB drivers for the evaluation board. [Section 4](#) briefly explains how the EB can be used throughout a project's development cycle. [Section 5](#) gives an overview of the various features and functionality provided by the board.

A troubleshooting guide is found in [Section 7](#) and [Appendix A](#) contains the schematics for SmartRF06EB revision 1.2.1.

The PC tools SmartRF Studio and SmartRF Flash Programmer have their own user manual.

For references to relevant documents and web pages, see [Section 8](#).

2.1 Acronyms

Table 2. Acronyms

Acronym	Description
ALS	Ambient Light Sensor
cJTAG	Compact JTAG (IEEE 1149.7)
CW	Continuous Wave
DK	Development Kit
EB	Evaluation Board
EVM	Evaluation Module
FPGA	Field-Programmable Gate Array
I/O	Input/Output
JTAG	Joint Test Action Group (IEEE 1149.1)
LCD	Liquid Crystal Display
LED	Light Emitting Diode
LPRF	Low Power RF
MCU	Microcontroller
MISO	Master In, Slave Out (SPI signal)
MOSI	Master Out, Slave In (SPI signal)
NA	Not Applicable / Not Available
NC	Not Connected
RF	Radio Frequency
RTS	Request to Send
RX	Receive
SoC	System-on-Chip
SPI	Serial Peripheral Interface
TI	Texas Instruments
TP	Test Point
TX	Transmit
UART	Universal Asynchronous Receive Transmit
USB	Universal Serial Bus
VCP	Virtual COM Port

3 Getting Started

Before connecting the SmartRF06EB to the PC via the USB cable, it is highly recommended to perform the steps described below.

3.1 Installing SmartRF Studio and USB Drivers

Before your PC can communicate with the SmartRF06EB over USB, the USB drivers for the EB needs to be installed. The latest SmartRF Studio installer [\[1\]](#) includes USB drivers both for Windows x86 and Windows x64 platforms.

After you have downloaded SmartRF Studio from the web, extract the zip-file, run the installer and follow the instructions. Select the complete installation to include the SmartRF Studio program, the SmartRF Studio documentation and the necessary drivers needed to communicate with the SmartRF06EB.

3.1.1 SmartRF Studio

SmartRF Studio is a PC application developed for configuration and evaluation of many RF-IC products from Texas Instruments. The application is designed for use with SmartRF Evaluation Boards, such as SmartRF06EB, and runs on the Microsoft Windows operating systems.

SmartRF Studio lets you explore and experiment with the RF-ICs as it gives full overview and access to the devices' registers to configure the radio and has a control interface for simple radio operation from the PC.

This means that SmartRF Studio will help radio system designers to easily evaluate the RF-IC at an early stage in the design process. It also offers a flexible code export function of radio register settings for software developers.

The latest version of SmartRF Studio can be downloaded from the Texas Instruments website [1], where a complete user manual can be found.

3.1.2 FTDI USB Driver

SmartRF PC software such as SmartRF Studio uses a proprietary USB driver from FTDI [2] to communicate with SmartRF06 evaluation boards. Connect your SmartRF06EB to the computer with a USB cable and turn it on. If you did a complete install of SmartRF Studio, the device is automatically recognized by Windows and the SmartRF06EB is ready for use!

3.1.2.1 Install FTDI USB Driver Manually in Windows

If the SmartRF06EB was not properly recognized after plugging it into your PC, try the following steps to install the necessary USB drivers. The steps described are for Microsoft Windows 7, but are very similar to those in Windows XP and Windows Vista. It is assumed that you have already downloaded and installed the latest version of SmartRF Studio 7 [1].

Open the Windows Device Manager and right click on the first "Texas Instruments XDS100v3" found under "Other devices" as shown in Figure 1.

Select "Update Driver Software..." and, in the appearing dialog, browse to <Studio install dir>\Drivers\ftdi as shown in Figure 2.

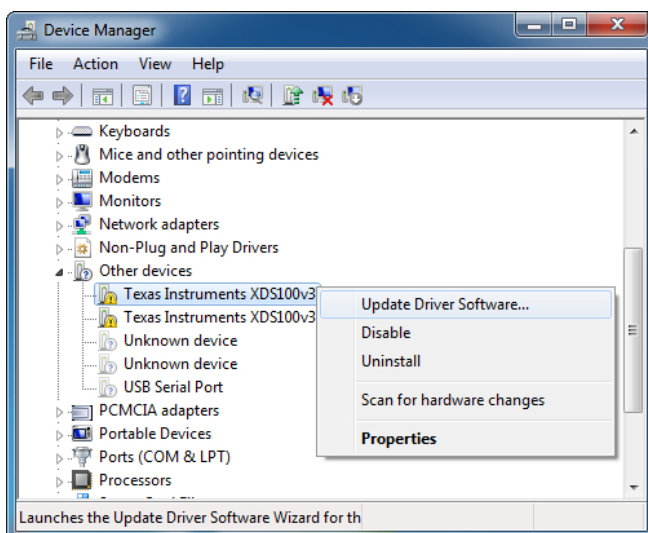

Figure 1. Driver Install: Update Driver

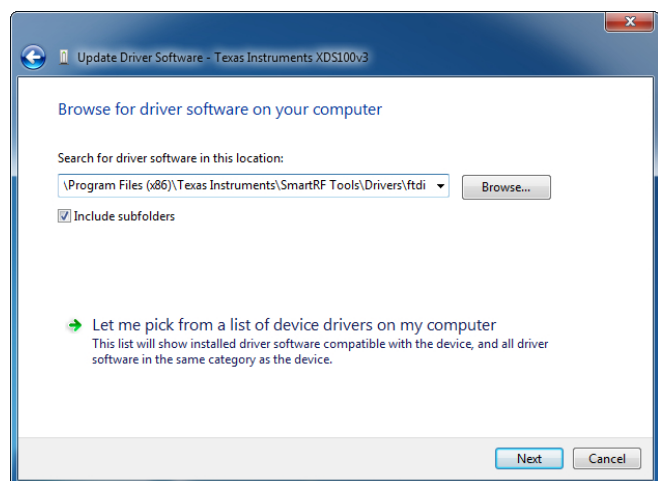

Figure 2. Driver Install: Specify Path to FTDI Drivers

Press Next and wait for the driver to be installed. The selected device should now appear in the Device Manager as "TI XDS100v3 Channel x" (x = A or B) as seen in Figure 4. Repeat the above steps for the second "Texas Instruments XDS100v3" listed under "Other devices".

3.1.2.1.1 Enable XDS100v3 UART Back Channel on Windows

If you have both “TI XDS100v3 Channel A” and “TI XDS100v3 Channel B” listed under Universal Serial Bus Controllers, you can proceed. Right click on “TI XDS100v3 Channel B” and select Properties. Under the Advanced tab, make sure “Load VCP” is checked as shown in [Figure 3](#).

A “USB Serial Port” may be listed under “Other devices”, as seen in [Figure 1](#). Follow the same steps as for the “Texas Instruments XDS100v3” devices to install the VCP driver. When the drivers from <Studio install dir>\Drivers\ftdi is properly installed, you should see the USB Serial Port device be listed under “Ports (COM & LPT)” as shown in [Figure 4](#).

The SmartRF06EB drivers are now installed correctly.

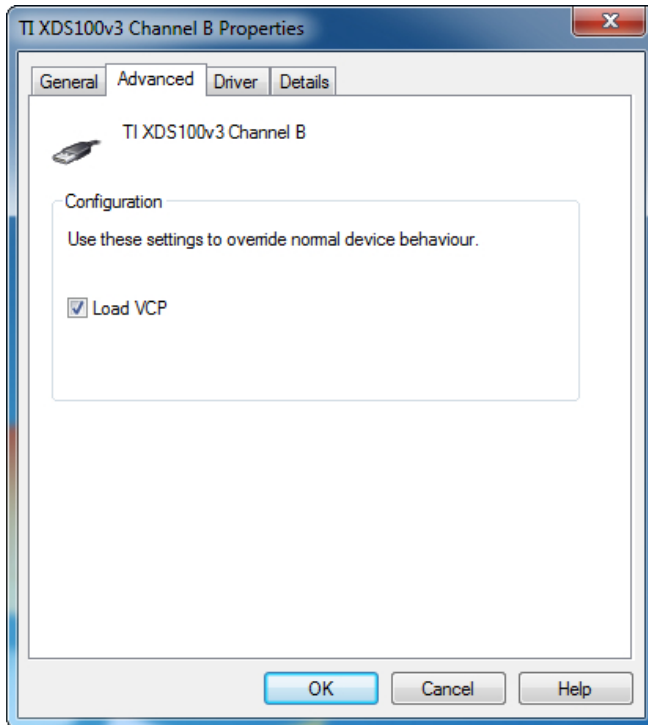

Figure 3. Driver Install: VCP Loaded

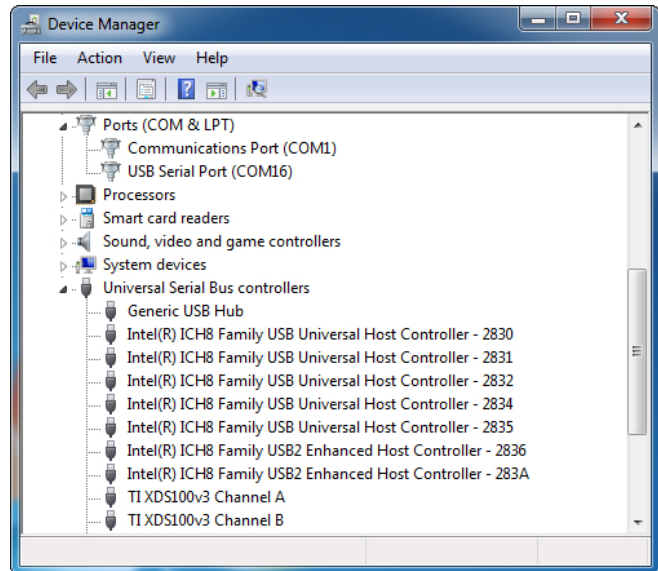

Figure 4. Driver Install: Drivers Successfully Installed

3.1.2.2 Install XSD100v3 UART Back Channel on Linux

The ports on SmartRF06EB will typically be mounted as *ttyUSB0* or *ttyUSB1*. The UART back channel is normally mounted as *ttyUSB1*.

1. Download the Linux drivers from [\[2\]](#).
2. Untar the *ftdi_sio.tar.gz* file on your Linux system.
3. Connect the SmartRF06EB to your system.
4. Install driver:
 - (a) Verify the USB Product ID (PID) and Vendor ID (VID). The TI XDS100v3 USB VID is 0x0403 and the PID is 0xA6D1, but if you wish to find the PID using a terminal window/shell, use

```
> lsusb | grep -i future.
```
 - (b) Install driver using modprobe In a terminal window/shell, navigate to the *ftdi_sio* folder and run

```
> sudo modprobe ftdi_sio vendor=0x403 product=0xA6D1 .
```

SmartRF06EB should now be correctly mounted. The above steps have been tested on Fedora and Ubuntu distributions.

If the above steps failed, try uninstalling ‘brltty’ prior to step 4 (technical note TN_101, [\[2\]](#)):

```
> sudo apt-get remove brltty.
```

4 Using the SmartRF06 Evaluation Board

The SmartRF06EB is a flexible test and development platform that works together with RF Evaluation Modules from Texas Instruments.

An Evaluation Module is a small RF module with RF chip, balun, matching filter, SMA antenna connector and I/O connectors. The modules can be plugged into the SmartRF06EB, which lets the PC take direct control of the RF device on the EVM over the USB interface.

SmartRF06EB currently supports: CC2538EM

SmartRF06EB is included in the CC2538 development kit.

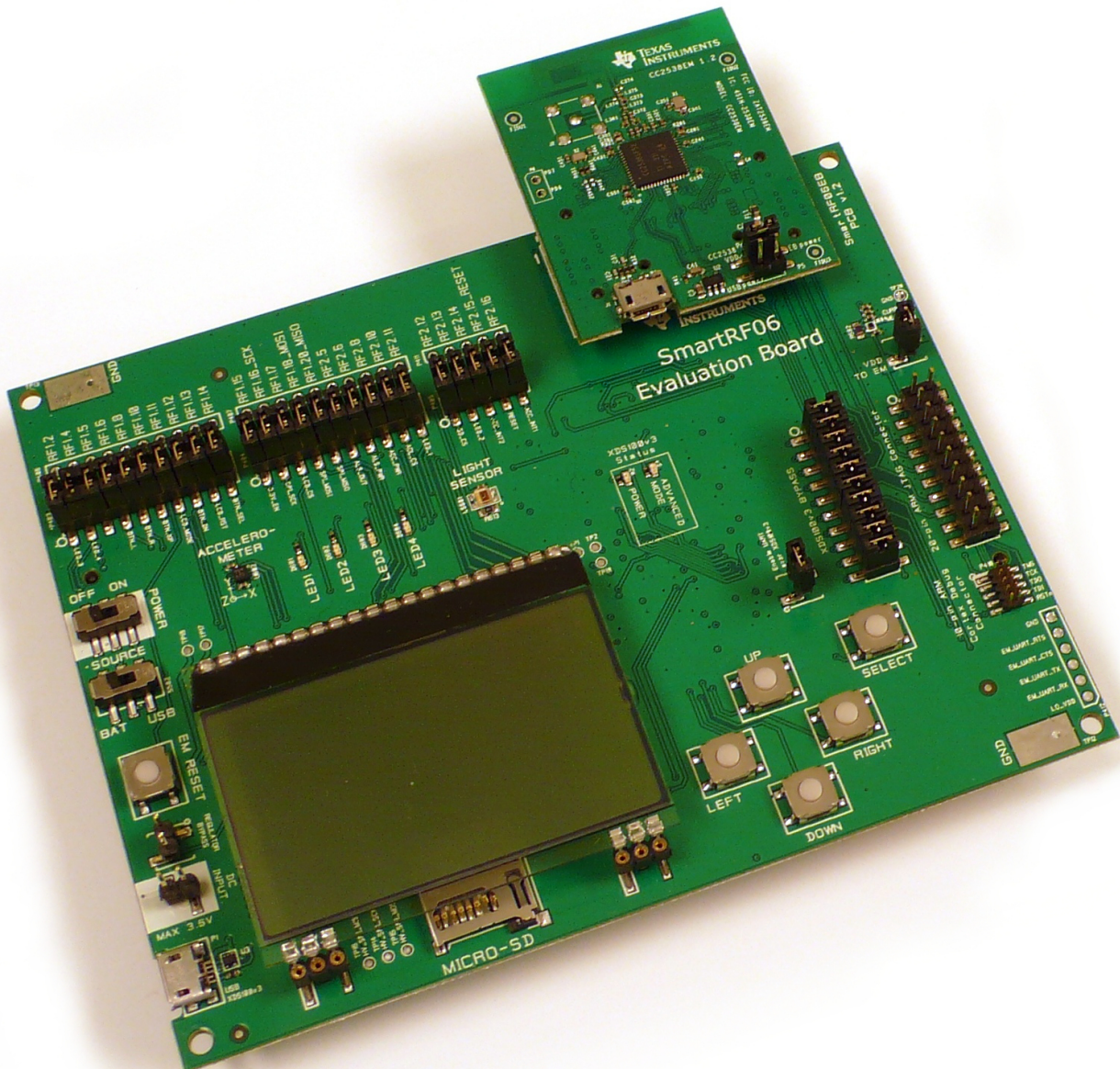

Figure 5. SmartRF06EB (rev. 1.2.1) With EVM Connected

The PC software that controls the SmartRF06EB + EVM is SmartRF Studio. Studio can be used to perform several RF tests and measurements, for example, to set up a CW signal and send or receive packets.

The EB+EVM can be of great help during the whole development cycle for a new RF product.

- Perform comparative studies. Compare results obtained with EB+EVM with results from your own system.
- Perform basic functional tests of your own hardware by connecting the radio on your board to SmartRF06EB. SmartRF Studio can be used to exercise the radio.
- Verify your own software with known good RF hardware, by simply connecting your own microcontroller to an EVM via the EB. Test the send function by transmitting packets from your software and receive with another board using SmartRF Studio. Then, transmit using SmartRF Studio and receive with your own software.
- Develop code for your SoC and use the SmartRF06EB as a standalone board without PC tools.

The SmartRF06EB can also be used as a debugger interface to the SoCs from IAR Embedded workbench for ARM or Code Composer Studio from Texas Instruments. For details on how to use the SmartRF06EB to debug external targets, see [Section 6](#).

4.1 Absolute Maximum Ratings

The minimum and maximum operating supply voltages and absolute maximum ratings for the active components onboard the SmartRF06EB are summarized in [Table 3](#). [Table 3](#) lists the recommended operating temperature and storage temperature ratings. For more details, see the device-specific data sheet.

Table 3. Supply Voltage: Recommended Operating Conditions and Absolute Maximum Ratings

Component	Operating Voltage		Absolute Maximum Rating	
	Min [V]	Max [V]	Min [V]	Max [V]
XDS100v3 Emulator ⁽¹⁾ [4]	+1.8	+3.6	-0.3	+3.75
LCD [5]	+3.0	+3.3	-0.3	+3.6
Accelerometer [6]	+1.62	+3.6	-0.3	+4.25
Ambient light sensor [7]	+2.3 ⁽²⁾	+5.5	NA	+6

⁽¹⁾ The XDS100v3 Emulator is USB powered. Values refer to the supply and I/O pin voltages of the connected target.

⁽²⁾ Recommended minimum operating voltage.

Table 4. Temperature: Recommended Operating Conditions and Storage Temperatures

Component	Operating Voltage		Absolute Maximum Rating	
	Min [V]	Max [V]	Min [V]	Max [V]
XDS100v3 Emulator [4]	-20	+70	-50	+110
LCD [5]	-20	+70	-30	+80
Accelerometer [6]	-40	+85	-50	+150
Ambient light sensor [7]	-40	+85	-40	+85

5 SmartRF06 Evaluation Board Overview

SmartRF06EB acts as the motherboard in development kits for ARM Cortex-based low power RF SoCs from Texas Instruments. The board has several user interfaces and connections to external interfaces, allowing fast prototyping and testing of both software and hardware. An overview of the SmartRF06EB architecture is found in [Figure 6](#). The board layout is found in [Figure 7](#) and [Figure 8](#), while the schematics are located in Appendix A.

This section provides an overview of the general architecture of the board and describes the available I/O. The following subsections explain the I/O in more detail. Pin connections between the EVM and the evaluation board I/O can be found in [Section 5.10](#).

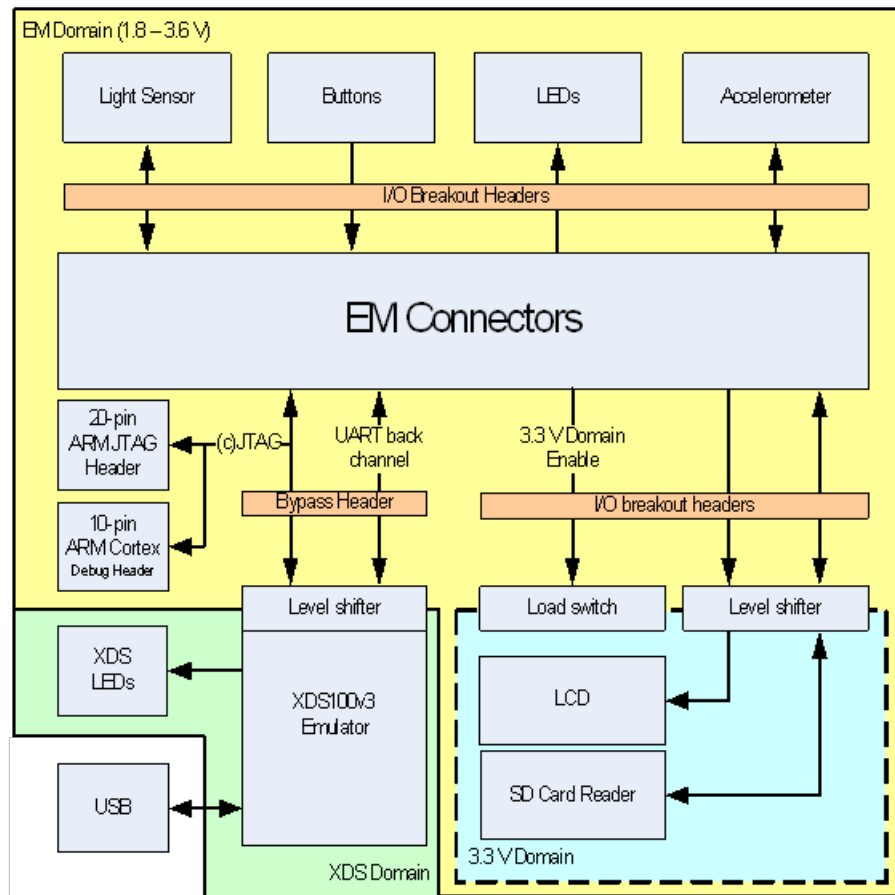

Figure 6. SmartRF06EB Architecture

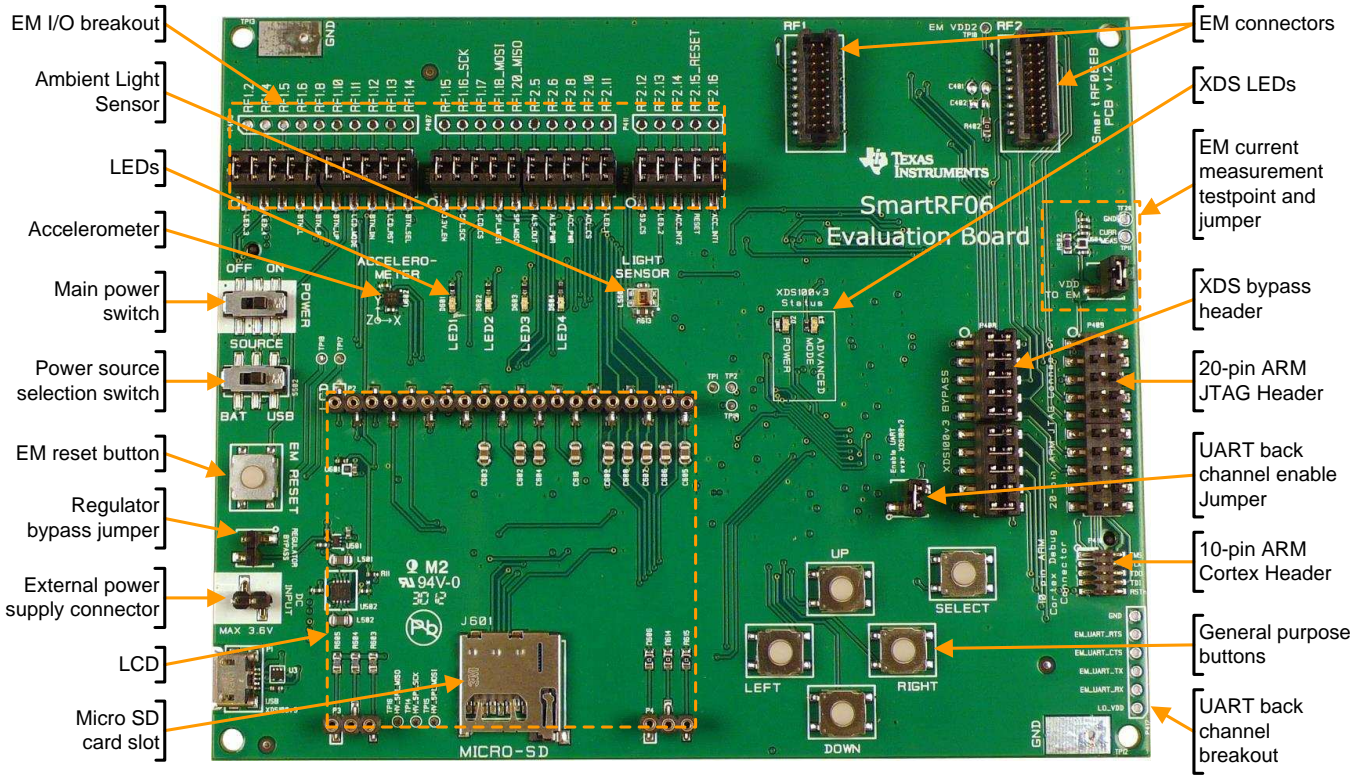

Figure 7. SmartRF06EB Revision 1.2.1 Front Side

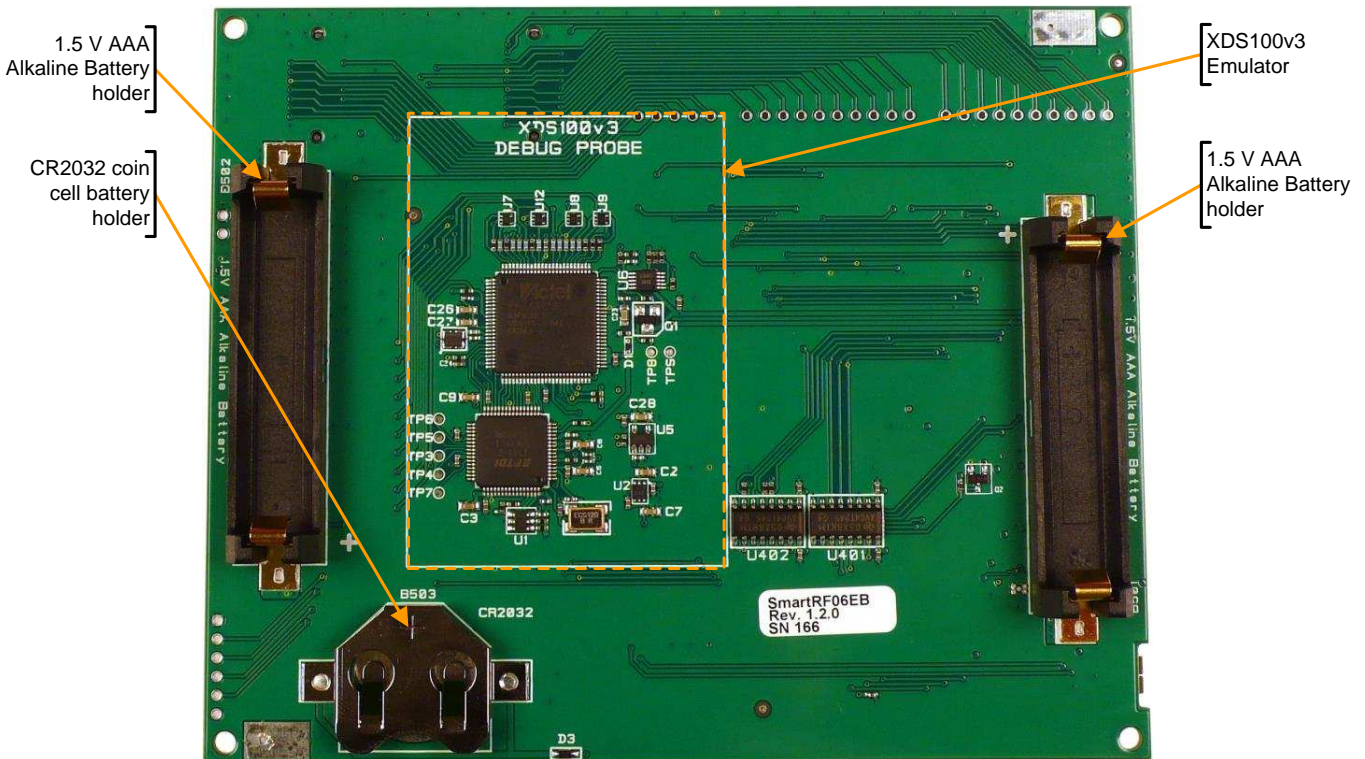

Figure 8. SmartRF06EB Revision 1.2.1 Reverse Side

5.1 XDS100v3 Emulator

The XDS100v3 Emulator from Texas Instruments has cJTAG and regular JTAG support. cJTAG is a 2-pin extension to regular 4-pin JTAG. The XDS100v3 consists of a USB to JTAG chip from FTDI [2] and an FPGA to convert JTAG instructions to cJTAG format.

In addition to regular debugging capabilities using cJTAG or JTAG, the XDS100v3 Emulator supports a UART backchannel over a USB Virtual COM Port (VCP) to the PC. The UART back channel supports flow control, 8-N-1 format and data rates up to 12Mbaud.

For detailed information about the emulator, see the XDS100v3 emulator product page [4]. The XDS100v3 Emulator is powered over USB and is switched on as long as the USB cable is connected to the SmartRF06EB and the main power switch (S501) is in the ON position. The XDS100v3 Emulator supports targets with operating voltages between 1.8 V and 3.6 V. The min (max) operating temperature is -20 (+70) °C.

5.1.1 UART Back Channel

The mounted EVM can be connected to the PC via the XDS100v3 Emulator's UART back channel. When connected to a PC, the XDS100v3 is enumerated as a Virtual COM Port (VCP) over USB. The driver used is a royalty free VCP driver from FTDI, available, for example, on Microsoft Windows, Linux and Max OS X. The UART back channel gives the mounted EVM access to a four pin UART interface, supporting 8-N-1 format at data rates up to 12 Mbaud.

To enable the SmartRF06EB UART back channel the "Enable UART over XDS100v3" jumper (J5), located on the lower right side of the EB, must be mounted (see Figure 9). Table 5 shows an overview of the I/O signals related to UART Back Channel.



Figure 9. Jumper Mounted on J5 to Enable the UART Back Channel

Table 5. UART Back Channel Signal Connections

Signal Name	Description	Probe Header	EVM Pin
RF1.7_UART_RX	UART receive (EVM data in)	EM_UART_RX (P412.2)	RF1.7
RF1.9_UART_TX	UART transmit (EVM data out)	EM_UART_TX (P412.3)	RF1.9
RF1.3_UART_CTS	UART clear to send signal	EM_UART_CTS (P412.4)	RF1.3
RF2.18_UART_RTS	UART request to send signal	EM_UART_RTS (P412.5)	RF2.18

5.2 Power Sources

There are three ways to power the SmartRF06EB: batteries, USB bus and external power supply. The power source can be selected using the power source selection switch (S502) seen in Figure 10. The XDS100v3 Emulator can only be powered over USB. The main power supply switch (S501) cuts power to the SmartRF06EB.

CAUTION

Never connect batteries and an external power source to the SmartRF06EB at the same time! Doing so may lead to excessive currents that may damage the batteries or cause onboard components to break. The CR2032 coin cell battery is in particular very sensitive to reverse currents (charging) and must never be combined with other power sources (AAA batteries or an external power source).

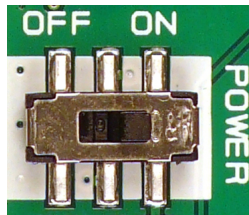

Figure 10. Main Power Switch (P501)

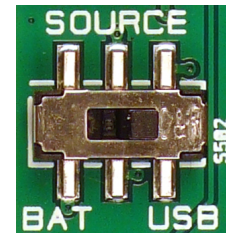

Figure 11. Source Selection Switch (P502)

5.2.1 USB Power

When the SmartRF06EB is connected to a PC via a USB cable, it can draw power from the USB bus. The onboard voltage regulator supplies approximately 3.3 V to the mounted EVM and the EB peripherals. To power the mounted EVM and the EB peripherals from the USB bus, the power source selection switch (S502) should be in “USB” position (see [Figure 12](#)).

The maximum current consumption is limited by the regulator to 1500 mA.

NOTE: Most USB power sources are limited to 500 mA.

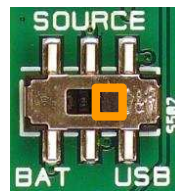

Figure 12. SmartRF06EB Power Selection Switch (P502) in “USB” Position

5.2.2 Battery Power

The SmartRF06EB can be powered using two 1.5 V AAA alkaline batteries or a 3 V CR2032 coin cell battery. The battery holders for the AAA batteries and the CR2032 coin cell battery are located on the reverse side of the PCB. To power the mounted EVM and the EB peripherals using batteries, the power source selection switch (S502) should be in “BAT” position (see [Figure 13](#)).

When battery powered, the EVM power domain is by default regulated to 2.1 V. The voltage regulator may be bypassed by mounting a jumper on J502. For more details, see [Section 5.3.2](#).

CAUTION

Do not power the SmartRF06EB using two 1.5 V AAA batteries and a 3 V CR2032 coin cell battery at the same time. Doing so may lead to excessive currents that may damage the batteries or cause onboard components to break

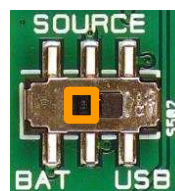

Figure 13. SmartRF06EB Power Source Selection Switch (P502) in “BAT” Position

5.2.3 External Power Supply

The SmartRF06EB can be powered using an external power supply. To power the mounted EVM and the EB peripherals using an external power supply, the power source selection switch (S502) should be in “BAT” position (see [Figure 13](#)).

The external supply’s ground should be connected to the SmartRF06EB ground, for example, to the ground pad in the top left corner of the EB. Connect the positive supply connector to the external power header J501 (see [Figure 14](#)). The applied voltage must be in the range from 2.1 V to 3.6 V and limited to max 1.5 A.

When powered by an external power supply, the EVM power domain is by default regulated to 2.1 V. The voltage regulator may be bypassed by mounting a jumper on J502. For more details, see [Section 5.3.2](#).

CAUTION

There is a risk of damaging the onboard components if the applied voltage on the external power connector/header is lower than -0.3 V or higher than 3.6 V (combined absolute maximum ratings for onboard components). For more information, see [Section 4.1](#).

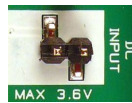

Figure 14. SmartRF06EB External Power Supply Header (J501)

5.3 Power Domains

The SmartRF06EB is divided into three power domains, described in detail in the following sections. The SmartRF06EB components, and what power domain they belong to, is shown in [Figure 15](#) and [Table 6](#).

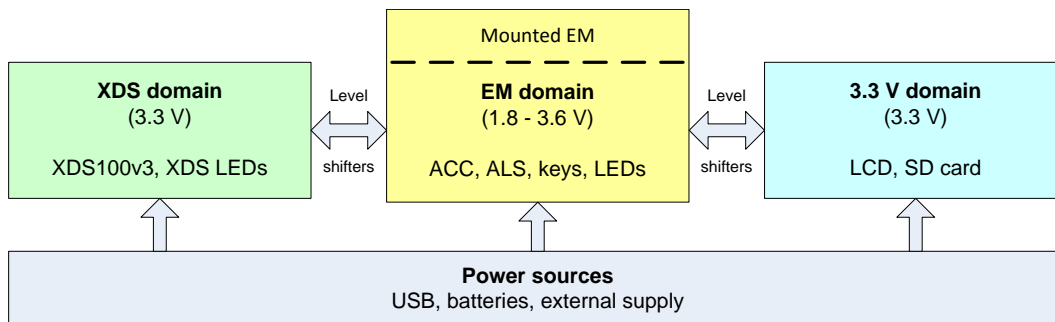

Figure 15. Power Domain Overview of SmartRF06EB

Table 6. Power Domain Overview of SmartRF06EB

Component	Power Domain	Power Source
Evaluation Module	EVM domain (LO_VDD)	USB, battery, external
General Purpose LEDs	EVM domain (LO_VDD)	USB, battery, external
Accelerometer	EVM domain (LO_VDD)	USB, battery, external
Ambient Light Sensor	EVM domain (LO_VDD)	USB, battery, external
Current Measurement MSP MCU	EVM domain (LO_VDD)	USB, battery, external
LEDs	EVM domain (LO_VDD)	USB, battery, external
XDS100v3 Emulator	XDS domain	USB
XDS100v3 LEDs	XDS domain	USB
SD Card Slot	3.3 V domain (HI_VDD)	Same as EVM domain
LCD	3.3 V domain (HI_VDD)	Same as EVM domain

5.3.1 XDS Domain

The XDS100v3 Emulator (see [Section 5.1](#)) onboard the SmartRF06EB is in the XDS domain. The XDS domain is powered over USB. The USB voltage supply (+5 V) is down-converted to +3.3 V and +1.5 V for the different components of the XDS100v3 Emulator.

The SmartRF06EB must be connected to a PC over USB for the XDS domain to be powered up. The domain is turned on or off by the SmartRF06EB main power switch.

5.3.2 EVM Domain

The mounted EVM board and most of the SmartRF06EB peripherals are powered in the EVM domain and signals in this domain (accessible by the EVM), are prefixed “LV_” in the schematics. [Table 6](#) lists the EB peripherals that are powered in the EVM domain. The domain is turned on or off by the SmartRF06EB power switch.

The EVM domain may be powered using various power sources: USB powered (regulated to 3.3 V), battery powered (regulated to 2.1 V or unregulated) and using an external power supply (regulated to 2.1 V or unregulated).

When battery powered or powered by an external source, the EVM power domain is by default regulated to 2.1 V using a step down converter. The step down converter may be bypassed by mounting a jumper on J502 (see [Figure 16](#)), powering the EVM domain directly from the source. When J502 is not mounted, the EVM power domain is regulated to 2.1 V. The maximum current consumption of the EVM power domain is then limited by the regulator to 410 mA.

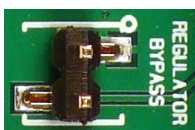

Figure 16. Mount a Jumper on J502 to Bypass EVM Domain Voltage Regulator

NOTE: Mounting a jumper on J502 will not have any effect if the SmartRF06EB is powered over USB (when the power source selection switch, S502, is in “USB” position).

5.3.3 3.3 V Domain

The 3.3 V domain is a sub domain of the EVM domain. The 3.3 V domain is regulated to 3.3 V using a buck-boost converter, irrespective of the source powering the EVM domain. Signals in the 3.3 V domain (controlled by the EVM) are prefixed “HV_” for High Voltage in the schematics.

Two EB peripherals are in the 3.3 V domain, the LCD and the SD card slot, as listed in [Table 6](#). These peripherals are connected to the EVM domain via level shifters U401 and U402.

The 3.3 V domain may be switched on (off) completely by the mounted EVM board by pulling signal LV_3.3V_EN to a logical 1 (0). For details about the mapping between the EVM and signals onboard the SmartRF06EB, see [Table 15](#).

5.4 LCD

The SmartRF06EB comes with a 128x64 pixels display from Electronic Assembly (DOG128E-6) [\[4\]](#). The LCD display is available to mounted EVM via a SPI interface, enabling software development of user interfaces and demo use. [Table 7](#) shows an overview of the I/O signals related to the LCD.

The recommended operating condition for the LCD display is a supply voltage between 3.0 V and 3.3 V. The LCD display is powered from the 3.3 V power domain (HI_VDD). The min (max) operating temperature is –20 (+70) °C.

CAUTION

The LCD connector on SmartRF06EB is very tight to ensure proper contact between the EVM and the LCD. Be extremely cautious when removing the LCD to avoid the display from breaking.

Table 7. LCD Signal Connections

Signal Name	Description	Probe Header	EVM Pin
LV_3.3V_EN	3.3 V domain enable signal	RF1.15 (P407.1)	RF1.15
LV_LCD_MODE	LCD mode signal	RF1.11 (P406.7)	RF1.11
;LV_LCD_RESET	LCD reset signal (active low)	RF1.13 (P406.9)	RF1.13
;LV_LCD_CS	LCD chip select (active low)	RF1.17 (P407.3)	RF1.17
LV_SPI_SCK	SPI clock	RF1.16_SCK (P407.2)	RF1.16
LV_SPI_MOSI	SPI MOSI (LCD input)	RF1.18_MOSI (P407.4)	RF1.18

5.5 Micro SD Card Slot

The SmartRF06EB has a micro SD card slot for connecting external SD/MMC flash devices (flash device not included). A connected flash device is available to the mounted EVM via a SPI interface, giving it access to extra flash, enabling over-the-air upgrades and more. [Table 9](#) shows an overview of I/O signals related to the micro SD card slot.

The micro SD card is powered from the 3.3 V power domain (HI_VDD).

Table 8. Micro SD Card Signal Connections

Signal Name	Description	Probe Header	EVM Pin
LV_3.3V_EN	3.3 V domain enable signal ⁽¹⁾	RF1.15 (P407.1)	RF1.15
;LV_SDCARD_CS	SD card chip select (active low)	RF2.12 (P411.1)	RF2.12
LV_SPI_SCK	SPI clock	RF1.16_SCK (P407.2)	RF1.16
LV_SPI_MOSI	SPI MOSI (SD card input)	RF1.18_MOSI (P407.4)	RF1.18
LV_SPI_MISO	SPI MISO (SD card output)	RF1.20_MISO (P407.5)	RF1.20

⁽¹⁾ The LCD and SD card are both powered in the 3.3 V domain and cannot be powered on or off individually.

5.6 Accelerometer

The SmartRF06EB is equipped with a BMA250E digital accelerometer from Bosch Sensortech [6]. The accelerometer is available to the mounted EVM via an SPI interface and has two dedicated interrupt lines. The accelerometer is suitable for application development, prototyping and demo use. Table 9 shows an overview of I/O signals related to the accelerometer.

Note that some versions of the SmartRF06EB (1.2.2 and earlier – see the sticker on bottom side of PCB) used the original BMA250 IC, while later versions (1.2.3 and later) use BMA250E. The primary difference is that the BMA250E uses a different device ID. For more information, see the Bosch Sensortech data sheet [6].

The recommended operating condition for the accelerometer is a supply voltage between 1.62 V and 3.6 V. The min (max) operating temperature is -40 (+85) °C

Table 9. Accelerometer Signal Connections

Signal Name	Description	Probe Header	EVM Pin
LV_ACC_PWR	Acc. power enable signal	RF2.8 (P407.8)	RF2.8
LV_ACC_INT1	Acc. interrupt signal	RF2.16 (P411.5)	RF2.16
LV_ACC_INT2	Acc. interrupt signal	RF2.14 (P411.3)	RF2.14
LV_ACC_CS	Acc. chip select (active low)	RF2.10 (P407.9)	RF2.10
LV_SPL_SCK	SPI clock	RF1.16_SCK (P407.2)	RF1.16
LV_SPL_MOSI	SPI MOSI (acc. input)	RF1.18_MOSI (P407.4)	RF1.18
LV_SPL_MISO	SPI MISO (acc. output)	RF1.20_MISO (P407.5)	RF1.20

5.7 Ambient Light Sensor

The SmartRF06EB has an analog SFH 5711 ambient light sensor (ALS) from Osram [7] that is available for the mounted EVM via the EVM connectors, enabling quick application development for demo use and prototyping. Figure 17 and Table 10 shows an overview of I/O signals related to the ambient light sensor.

The recommended operating condition for the ambient light sensor is a supply voltage between 2.3 V and 5.5 V. The min (max) operating temperature is -40 (+85) °C.

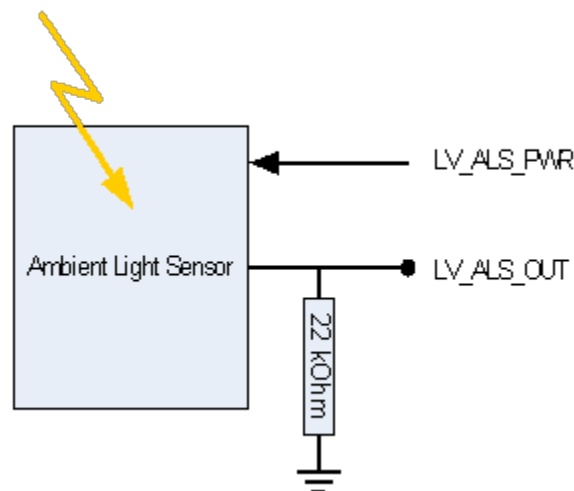

Figure 17. Simplified Schematic of Ambient Light Sensor Setup

Table 10. Ambient Light Sensor Signal Connections

Signal Name	Description	Probe Header	EVM Pin
LV_ALS_PWR	ALS power enable signal	RF2.6 (P407.7)	RF2.6
LV_ALS_OUT	ALS output signal (analog)	RF2.5 (P411.6)	RF2.5

5.8 Buttons

There are six buttons on the SmartRF06EB. Status of the LEFT, RIGHT, UP, DOWN and SELECT buttons are available to the mounted EVM. These buttons are intended for user interfacing and development of demo applications.

The EVM RESET button resets the mounted EVM by pulling its reset line low (RF2.15_RESET); [Table 11](#) shows an overview of I/O signals related to the buttons.

Table 11. Button Signal Connections

Signal Name	Description	Probe Header	EVM Pin
LV_BTN_LEFT	Left button (active low)	RF1.6 (P406.4)	RF1.6
LV_BTN_RIGHT	Right button (active low)	RF1.8 (P406.5)	RF1.8
LV_BTN_UP	Up button (active low)	RF1.10 (P406.6)	RF1.10
LV_BTN_DOWN	Down button (active low)	RF1.12 (P406.8)	RF1.12
LV_BTN_SELECT	Select button (active low)	RF1.14 (P406.10)	RF1.14
:LV_BTN_RESET	EVM reset button (active low)	<u>RF2.15_RESET</u> ; (P411.4)	RF2.15

5.9 LEDs

5.9.1 General Purpose LEDs

The four LEDs D601, D602, D603, D604 can be controlled from the mounted EVM and are suitable for demo use and debugging. The LEDs are active high. [Table 12](#) shows an overview of I/O signals related to the LEDs.

Table 12. General Purpose LED Signal Connections

Signal Name	Description	Probe Header	EVM Pin
LV_LED_1	LED 1 (red)	RF2.11 (P407.10)	RF2.11
LV_LED_2	LED 2 (yellow)	RF2.13 (P411.2)	RF2.13
LV_LED_3	LED 3 (green)	RF1.2 (P406.1)	RF1.2
LV_LED_4	LED 4 (red-orange)	RF1.4 (P406.2)	RF1.4

5.9.2 XDS100v3 Emulator LEDs

The XDS100v3 emulator has two LEDs to indicate its status: D2 and D4. The LEDs are located on the top side of the SmartRF06EB. LED D2 is lit whenever the XDS100v3 Emulator is powered, while LED D4 (ADVANCED MODE) is lit when the XDS100v3 is in an active cJTAG debug state.

5.10 EVM Connectors

The EVM connectors, shown in [Figure 18](#), are used for connecting an EVM board to the SmartRF06EB. The connectors RF1 and RF2 are the main interface and are designed to inhibit incorrect mounting of the EVM board. The pin-out of the EVM connectors is given in [Table 13](#) and [Table 14](#).



Figure 18. SmartRF06EB EVM Connectors RF1 and RF2

Table 13. EVM connector RF1 Pin Out

EVM Pin	Signal Name	Description	Probe Header	Breakout Header
RF1.1	GND	Ground		
RF1.2	RF1.2	GPIO signal to EVM board	P406.1	P403.1-2
RF1.3	RF1.3_UART_CTS	UART back channel / GPIO	P412.4	P408.15-16
RF1.4	RF1.4	GPIO signal to EVM board	P406.2	P403.3-4
RF1.5	RF1.5	GPIO signal to EVM board	P406.3	P403.5-6
RF1.6	RF1.6	GPIO signal to EVM board	P406.4	P403.7-8
RF1.7	RF1.7_UART_RX	UART back channel (EVM RX)	P412.2	P408.11-12
RF1.8	RF1.8	GPIO signal to EVM board	P406.5	P403.9-10
RF1.9	RF1.9_UART_TX	UART back channel (EVM TX)	P412.3	P408.13-14
RF1.10	RF1.10	GPIO signal to EVM board	P406.6	P403.11-12
RF1.11	RF1.11	GPIO signal to EVM board	P406.7	P403.13-14
RF1.12	RF1.12	GPIO signal to EVM board	P406.8	P403.15-16
RF1.13	RF1.13	GPIO signal to EVM board	P406.9	P403.17-18
RF1.14	RF1.14	GPIO signal to EVM board	P406.10	P403.19-20
RF1.15	RF1.15	GPIO signal to EVM board	P407.1	P404.1-2
RF1.16	RF1.16_SPI_SCK	EVM SPI Clock	P407.2	P404.3-4
RF1.17	RF1.17	GPIO signal to EVM board	P407.3	P404.5-6
RF1.18	RF1.18_SPI_MOSI	EVM SPI MOSI	P407.4	P404.7-8
RF1.19	GND	Ground		
RF1.20	RF1.20_SPI_MISO	EVM SPI MISO	P407.5	P404.9-10

Table 14. EVM Connector RF2 Pin Out

EVM Pin	Signal Name	Description	Probe Header	Breakout Header
RF2.1	RF2.1_JTAG_TCK	JTAG test clock	P409.9	P408.1-2
RF2.2	GND	Ground		
RF2.3	RF_VDD2	EVM power	TP10	J503.1-2
RF2.4	RF2.4_JTAG_TMS	JTAG test mode select	P409.7	P408.3-4
RF2.5	RF2.5	GPIO signal to EVM board	P407.6	P404.11-12
RF2.6	RF2.6	GPIO signal to EVM board	P407.7	P404.13-14
RF2.7	RF_VDD1	EVM power	TP10	J503.1-2
RF2.8	RF2.8	GPIO signal to EVM board	P407.8	P404.15-16
RF2.9	RF_VDD1	EVM power	TP10	J503.1-2
RF2.10	RF2.10	GPIO signal to EVM board	P407.9	P404.17-18
RF2.11	RF2.11	GPIO signal to EVM board	P407.10	P404.19-20
RF2.12	RF2.12	GPIO signal to EVM board	P411.1	P405.1-2
RF2.13	RF2.13	GPIO signal to EVM board	P411.2	P405.3-4
RF2.14	RF2.14	GPIO signal to EVM board	P411.3	P405.5-6
RF2.15	<u>RF2.15_RESET;</u>	EVM reset signal (active low)	P411.4	P405.7-8
RF2.16	RF2.16	GPIO signal to EVM board	P411.5	P405.9-10
RF2.17	RF2.17_JTAG_TDI	GPIO / JTAG test data in	P409.5	P408.5-6
RF2.18	RF2.18_UART_RTS	GPIO / UART back channel	P412.5	P408.17-18
RF2.19	RF2.19_JTAG_TDO	GPIO / JTAG test data out	P409.13	P408.7-8
RF2.20	GND	Ground		

5.11 Breakout Headers and Jumpers

The SmartRF06EB has several breakout headers, giving access to all EVM connector pins. An overview of the SmartRF06EB I/O breakout headers is given in Figure 19. Probe headers P406, P407, P411 and P412 give access to the I/O signals of the mounted EVM. Breakout headers P403, P404 and P405 allow the user to map any EVM I/O signal to any peripheral on the SmartRF06EB.

The XDS bypass header (P408) makes it possible to disconnect the XDS100v3 Emulator onboard the EB from the EVM. Using the 20-pin ARM JTAG header (P409) or the 10-pin ARM Cortex Debug Header (P410), it is possible to debug external targets using the onboard emulator.

NOTE: By default, all jumpers are mounted on P403, P404, P405 and P408. The default configuration is assumed in this user's guide, unless otherwise stated.

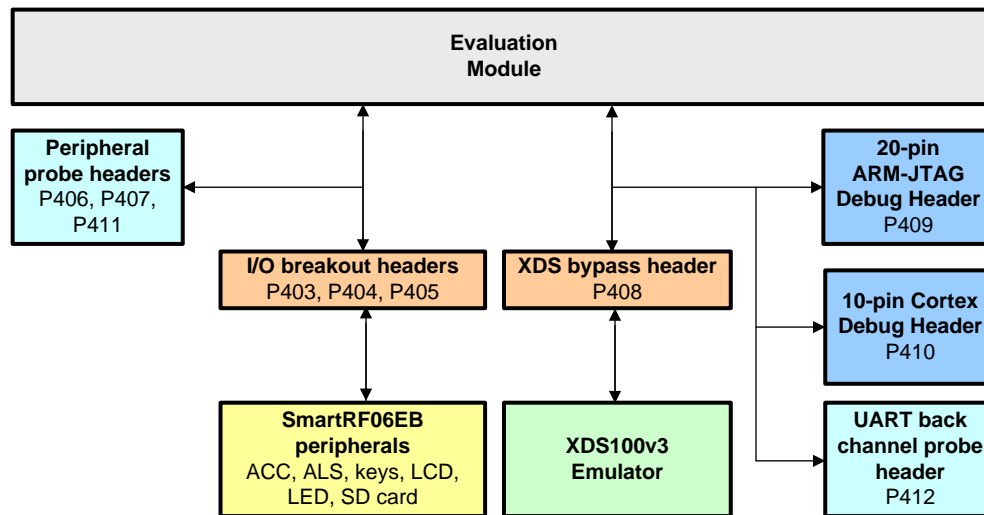

Figure 19. SmartRF06EB I/O Breakout Overview

5.11.1 I/O Breakout Headers

The I/O breakout headers on SmartRF06EB consist of pin connectors P406, P407, P411 and P412. P406, P407 and P411 are located at the top left side of SmartRF06EB. All EVM signals available on these probe headers can be connected to or disconnected from SmartRF06EB peripherals using jumpers on headers P403, P404, P405.

Probe header P412 is located near the bottom right corner of the SmartRF06EB. The signals available on P412 are connected to the XDS100v3 Emulator's UART back channel using jumpers on header P408.

The I/O breakout mapping between the SmartRF06EB and the mounted EVM is given in [Table 15](#). The leftmost column in the table refers to the silk print seen on the SmartRF06EB. The rightmost column shows the corresponding CC2538 I/O pad on CC2538EM.

Table 15. SmartRF06EB I/O Breakout Overview

Probe Header	Silk Print	EB Signal Name	EVM Connector	CC2538EM I/O
P406	RF1.2	LV_LED_3	RF1.2	PC2
	RF1.4	LV_LED_4	RF1.4	PC3
	RF1.5	NC	RF1.5	PB1
	RF1.6	LV_BTN_LEFT	RF1.6	PC4
	RF1.8	LV_BTN_RIGHT	RF1.8	PC5
	RF1.10	LV_BTN_UP	RF1.10	PC6
	RF1.11	LV_LCD_MODE	RF1.11	PB2
	RF1.12	LV_BTN_DOWN	RF1.12	PC7
	RF1.13	;LV_LCD_RESET	RF1.13	PB3
	RF1.14	LV_BTN_SELECT	RF1.14	PA3
P407	RF1.15	LV_3.3V_EN	RF1.15	PB4
	RF1.16_SCK	LV_SPI_SCK	RF1.16	PA2
	RF1.17	;LV_LCD_CS	RF1.17	PB5
	RF1.18_MOSI	LV_SPI_MOSI	RF1.18	PA4
	RF1.20_MISO	LV_SPI_MISO	RF1.20	PA5
	RF2.5	LV_ALS_OUT	RF2.5	PA6
	RF2.6	LV_ALS_PWR	RF2.6	PA7
	RF2.8	LV_ACC_PWR	RF2.8	PD4
	RF2.10	;LV_ACC_CS	RF2.10	PD5
	RF2.11	LV_LED_1	RF2.11	PC0
P411	RF2.12	;LV_SDCARD_CS	RF2.12	PD0
	RF2.13	LV_LED_2	RF2.13	PC1
	RF2.14	LV_ACC_INT2	RF2.14	PD1
	RF2.15_RESET	;LV_BTN_RESET	RF2.15	nRESET
	RF2.16	LV_ACC_INT1	RF2.16	PD2
P412	EM_UART_RX	RF1.7_UART_RX	RF1.7	PA0
	EM_UART_TX	RF1.9_UART_TX	RF1.9	PA1
	EM_UART_CTS	RF1.3_UART_CTS	RF1.3	PB0
	EM_UART_RTS	RF2.18_UART_RTS	RF2.18	PD3

5.11.2 XDS100v3 Emulator Bypass Headers

The XDS100v3 Emulator bypass header, P408, is by default mounted with jumpers (see [Figure 20](#)), connecting the XDS100v3 Emulator to a mounted EVM or external target. By removing the jumpers on P408, the XDS100v3 Emulator can be disconnected from the target.

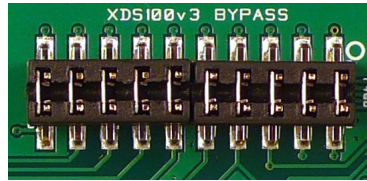

Figure 20. XDS100v3 Emulator Bypass Header (P408)

5.11.3 20-Pin ARM JTAG Header

The SmartRF06EB comes with a standard 20-pin ARM JTAG header [8] (see [Figure 21](#)), enabling the user to debug an external target using the XDS100v3 Emulator. The pin-out of the ARM JTAG header is given in [Table 16. Section 6](#) has more information on how to debug an external target using the XDS100v3 Emulator onboard the SmartRF06EB.

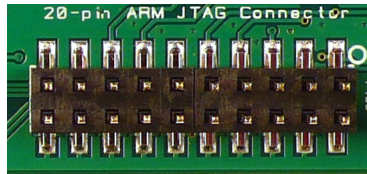

Figure 21. 20-Pin ARM JTAG Header (P409)

Table 16. 20-Pin ARM JTAG Header Pin-Out (P409)

Pin	Signal	Description	EB Signal Name	XDS Bypass Header
P409.1	VTRef	Voltage reference	VDD_SENSE	P408.19-20
P409.2	VSupply	Voltage supply	NC	
P409.3	nTRST	Test reset	NC	
P409.4	GND	Ground	GND	
P409.5	TDI	Test data in	RF2.17_JTAG_TDI	P408.5-6
P409.6	GND	Ground	GND	
P409.7	TMS	Test mode select	RF2.4_JTAG_TMS	P408.3-4
P409.8	GND	Ground	GND	
P409.9	TCK	Test clock	RF2.1_JTAG_TCK	P408.1-2
P409.10	GND	Ground	GND	
P409.11	RTCK	Return clock	NC	
P409.12	GND	Ground	GND	
P409.13	TDO	Test data out	RF2.19_JTAG_TDO	P408.7-8
P409.14	GND	Ground	GND	
P409.15	nSRST	System reset	RF2.15_RESET;	P408.9-10
P409.16	GND	Ground	GND	
P409.17	DBGREQ	Debug request	NC	
P409.18	GND	Ground	GND	
P409.19	DBGACK	Debug acknowledge	NC	
P409.20	GND	Ground	GND	

5.11.4 10-Pin ARM Cortex Debug Header

The SmartRF06EB comes with a standard 10-pin ARM Cortex debug header [8] (see [Figure 22](#)), enabling the user to debug an external target using the XDS100v3 Emulator. The ARM Cortex debug header is located near the right hand edge of the EB. The header pin-out is given in [Table 17](#). [Section 6](#) has more information on how to debug an external target using the XDS100v3 Emulator onboard the SmartRF06EB.

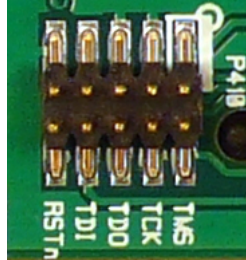

Figure 22. 10-Pin ARM Cortex Debug Header (P410)

Table 17. 10-Pin ARM Cortex Debug Header Pin-Out (P410)

Pin	Signal	Description	EB Signal Name	XDS Bypass Header
P410.1	VCC	Voltage reference	VDD_SENSE	P408.19-20
P410.2	TMS	Test mode select	RF2.4_JTAG_TMS	P408.3-4
P410.3	GND	Ground	GND	
P410.4	TCK	Test clock	RF2.1_JTAG_TCK	P408.1-2
P410.5	GND	Ground	GND	
P410.6	TDO	Test data out	RF2.19_JTAG_TDO	P408.7-8
P410.7	KEY	Key	NC	
P410.8	TDI	Test data in	RF2.17_JTAG_TDI	P408.5-6
P410.9	GNDDetect	Ground detect	GND	
P410.10	nRESET	System reset	RF2.15_RESET;	P408.9-10

5.12 Current Measurement

The SmartRF06EB provides two options for easy measurements of the current consumption of a mounted EVM. The following sections describe these two options in detail.

5.12.1 Current Measurement Jumper

SmartRF06EB has a current measurement header, J503, for easy measurement of EVM current consumption. Header J503 is located on the upper right hand side of the EB. By replacing the jumper with an ammeter, as shown in [Figure 23](#), the current consumption of the mounted EVM can be measured.



Figure 23. Measuring Current Consumption Using Jumper J503

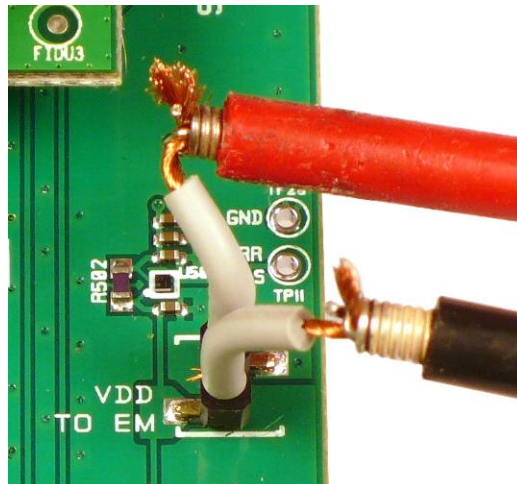

Figure 24. Measuring Current Consumption Using Jumper J503

6 Debugging an External Target Using SmartRF06EB

You can easily use XDS100v3 Emulator onboard the SmartRF06EB to debug an external target. In this section, it is assumed that the target is self-powered.

When debugging an external, self-powered target using SmartRF06EB, make sure to remove the jumper from the current measurement header (J503) as shown in the second scenario of Figure 25. In this scenario, the onboard XDS100v3 senses the target voltage of the external target. In the left side scenario of the same figure, the XDS100v3 senses the target voltage of the EB's EVM domain.

CAUTION

Having a jumper mounted on header J503 when debugging an external target causes a conflict between the EB's EVM domain supply voltage and the target's supply voltage. This may result in excess currents, damaging the onboard components of the SmartRF06EB or the target board.

In Figure 25, the right hand side scenario shows how it is possible to debug an EVM mounted on the SmartRF06EB using an external debugger. In this scenario, all the jumpers must be removed from the SmartRF06EB header P408 to avoid signaling conflicts between the onboard XDS100v3 Emulator and the external debugger.

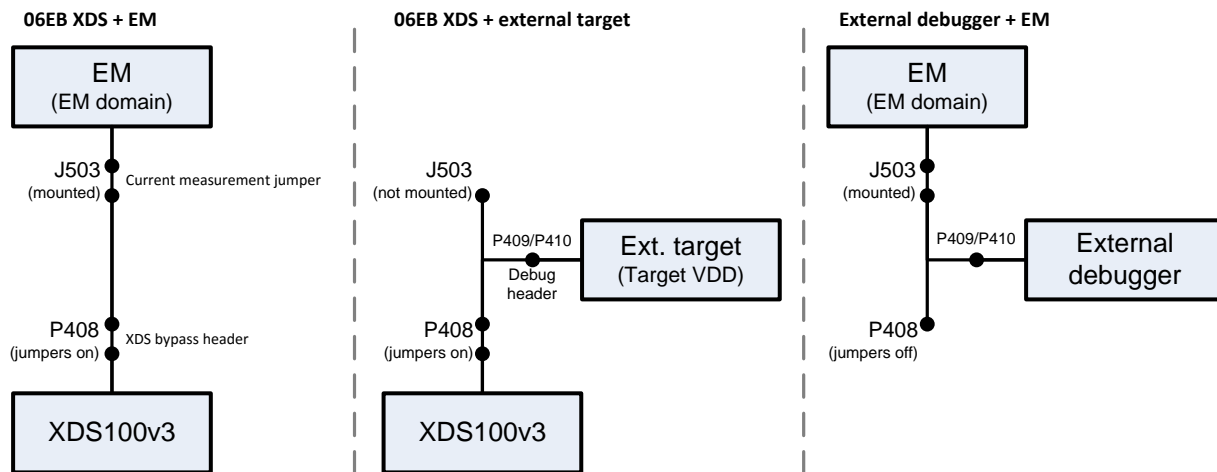

Figure 25. Simplified Connection Diagram for Different Debugging Scenarios

6.1 20-Pin ARM JTAG Header

The SmartRF06EB has a standard 20-pin ARM JTAG header mounted on the right hand side (P409). Make sure all the jumpers on the XDS bypass header (P408) are mounted and that the jumper is removed from header J503.

Connect the external board to the 20-pin ARM JTAG header (P409) using a 20-pin flat cable as seen in [Figure 26](#). Make sure pin 1 on P409 matches pin 1 on the external target. For more info about the 20-pin ARM JTAG header and the XDS bypass header, see [Section 5.11.2](#) and [Section 5.11.3](#).

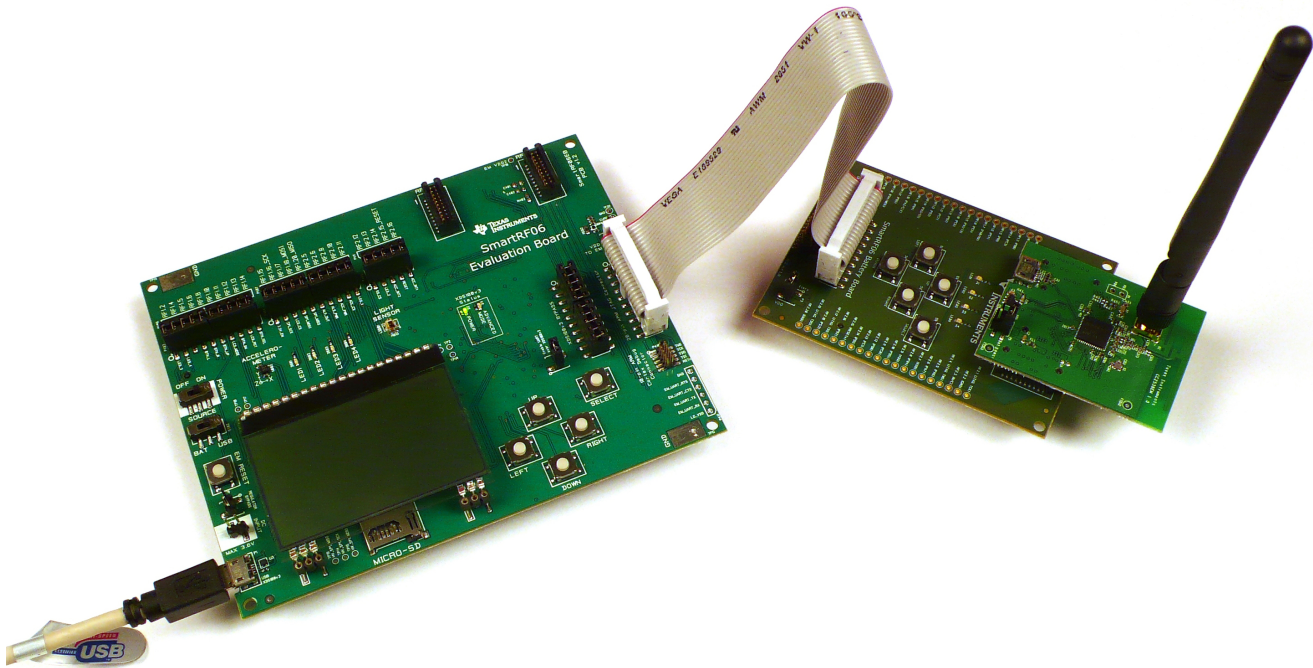

Figure 26. Debugging External Target Using SmartRF06EB

6.2 10-Pin ARM Cortex Debug Header

The SmartRF06EB has a standard 10-pin ARM Cortex Debug header mounted on the right hand side (P410). Make sure all the jumpers on the XDS bypass header (P408) are mounted and that the jumper is removed from header J503.

Connect the external board to the 10-pin ARM JTAG header using a 10-pin flat cable. Make sure pin 1 on P410 matches pin 1 on the external target. For more info about the 10-pin ARM Cortex Debug header and the XDS bypass header, see [Section 5.11.2](#) and [Section 5.11.4](#).

6.3 Custom Strapping

If the external board does not have a 20-pin ARM JTAG connector nor a 10-pin ARM Cortex connector, the needed signals may be strapped from the onboard XDS100v3 Emulator to the external target board.

Make sure all the jumpers on the XDS bypass header (P408) are mounted and that the jumper is removed from header J503. [Table 18](#) shows the signals that must be strapped between the SmartRF06EB and the target board. [Table 19](#) shows additional signals that are optional or needed for debugging using 4-pin JTAG. [Figure 27](#) shows where the signals listed in [Table 18](#) and [Table 19](#) can be found on the 20-pin ARM JTAG header.

Table 18. Debugging External Target: Minimum Strapping (cJTAG support)

EB Signal Name	EB Breakout	Description
VDD_SENSE	P409.1	Target voltage supply
GND	P409.4	Common ground for EB and external board
RF2.1_JTAG_TCK	P409.9	Test clock
RF2.4_JTAG_TMS	P409.7	Test mode select

Table 19. Debugging External Target: Optional Strapping

EB Signal Name	EB Breakout	Description
RF2.17_JTAG_TDI	P409.5	Test data in (optional for cJTAG)
RF2.19_JTAG_TDO	P409.13	Test data out (optional for cJTAG)
RF2.15_RESET;	P409.15	Target reset signal (optional)

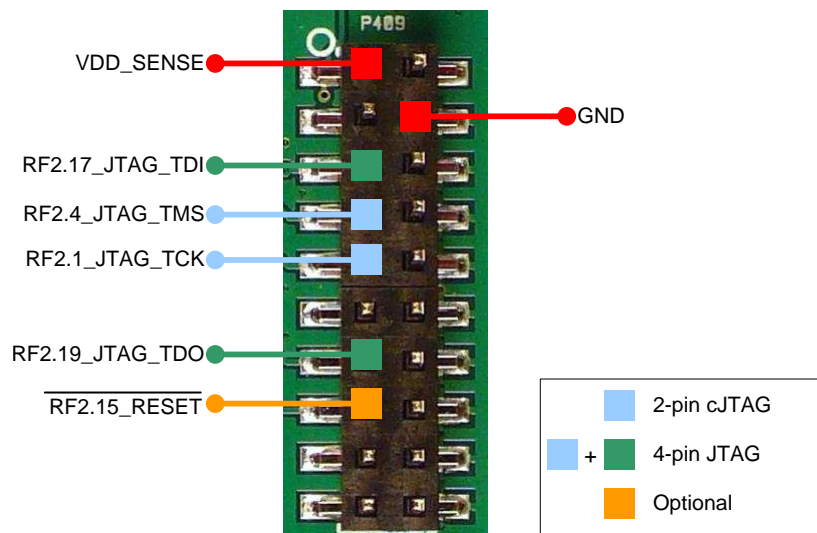

Figure 27. ARM JTAG Header (P409) With Strapping to Debug External Target

7 Frequently Asked Questions

Question: Nothing happens when I power up the evaluation board. Why?

Answer: Make sure that a power source is connected to the EB. Verify that the power source selection switch (S502) is set correctly according to your power source. When powering the EB from either batteries or an external power source, S502 should be in the “BAT” position. When powering the EB over USB, the switch should be in the “USB” position. Also, make sure the EVM current measurement jumper (J503) is short circuited.

Question: Why are there two JTAG connectors on the SmartRF06EB, and which one should I use?

Answer: The SmartRF06EB comes with two different standard debug connectors: the 20-pin ARM JTAG connector (P409) and the compact 10-pin ARM Cortex debug connector (P410). These debug connectors are there to more easily debug external targets without the need of customized strapping. For more details on how to debug external targets using the SmartRF06EB, see [Section 6](#).

Question: Can I use the SmartRF06EB to debug an 8051 SoC such as CC2530?

Answer: No, you cannot debug an 8051 SoC using the SmartRF06EB.

Question: When connecting my SmartRF06EB to my PC, no serial port appears. Why?

Answer: It may be that the virtual COM port on the SmartRF06EB’s XDS100 channel B has not been enabled. [Section 3.1.2.1.1](#) describes how to enable the Virtual COM Port in the USB driver.

8 References

1. [SmartRF Studio Product Page](#)
2. [FTDI USB Driver Page](#)
3. [SmartRF Flash Programmer Product Page](#)
4. [XDS100 Emulator Programmer wiki](#)
5. [Electronic Assembly DOGM128-6 Data Sheet](#)
6. [Bosch Sensortec BMA250 Data Sheet](#)
7. [Osram SFH 5711](#)
8. [Cortex-M Debug Connectors](#)

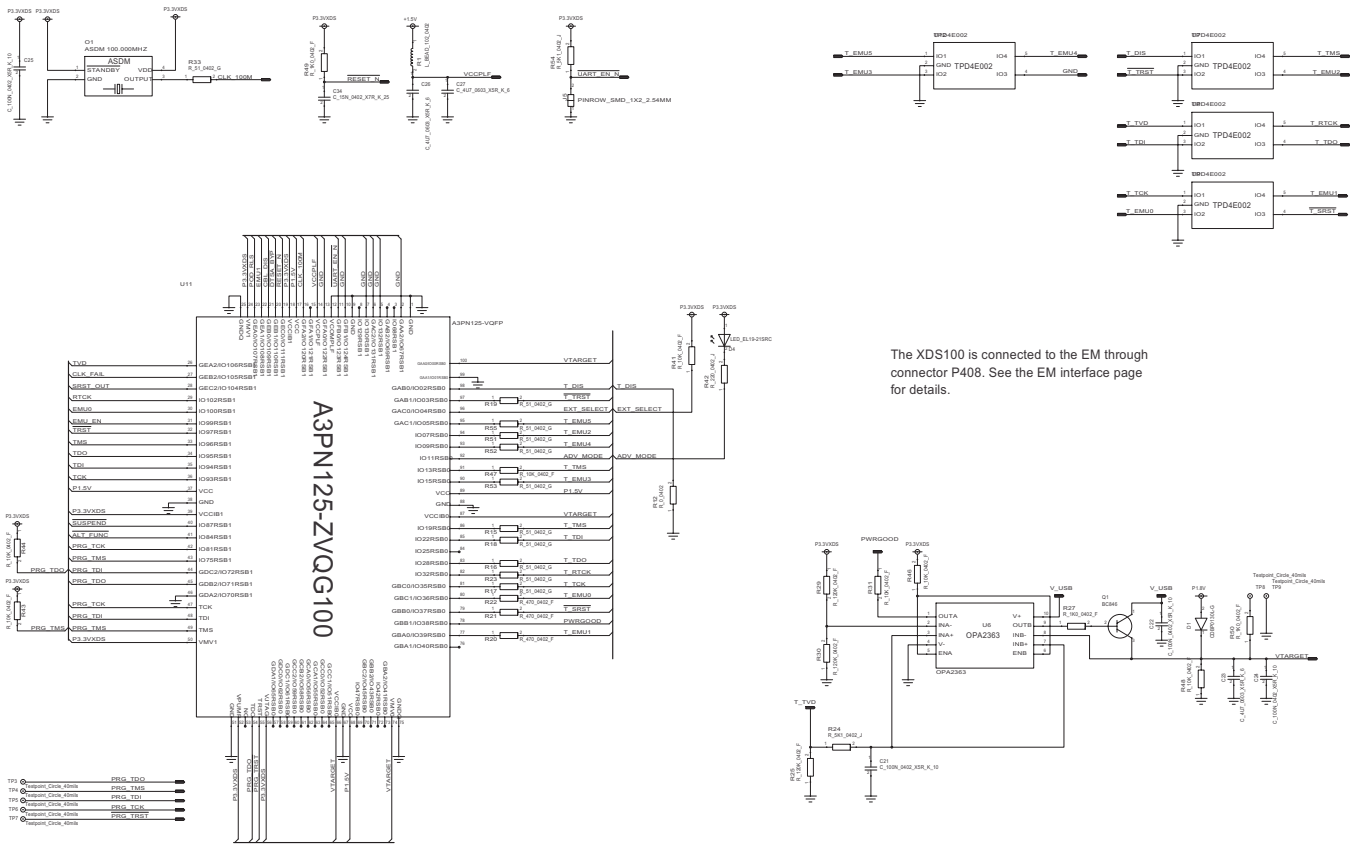

The XDS100 is connected to the EM through connector P408. See the EM interface page for details.

Copyright © 2017, Texas Instruments Incorporated

Figure 29. SmartRF06EB - XDS100v3 - FPGA

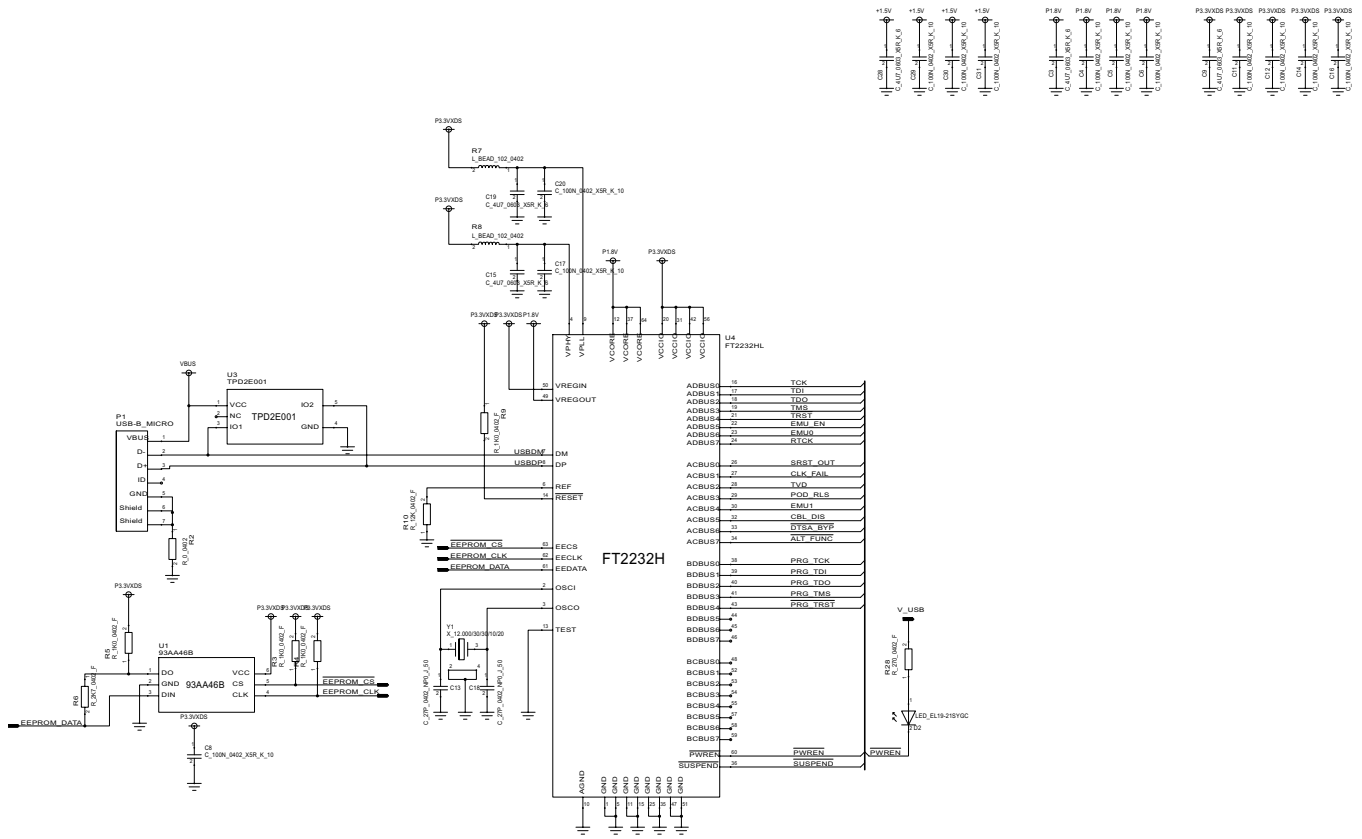

Copyright © 2017, Texas Instruments Incorporated

Figure 30. SmartRF06EB - XDS100v3 - FTDI

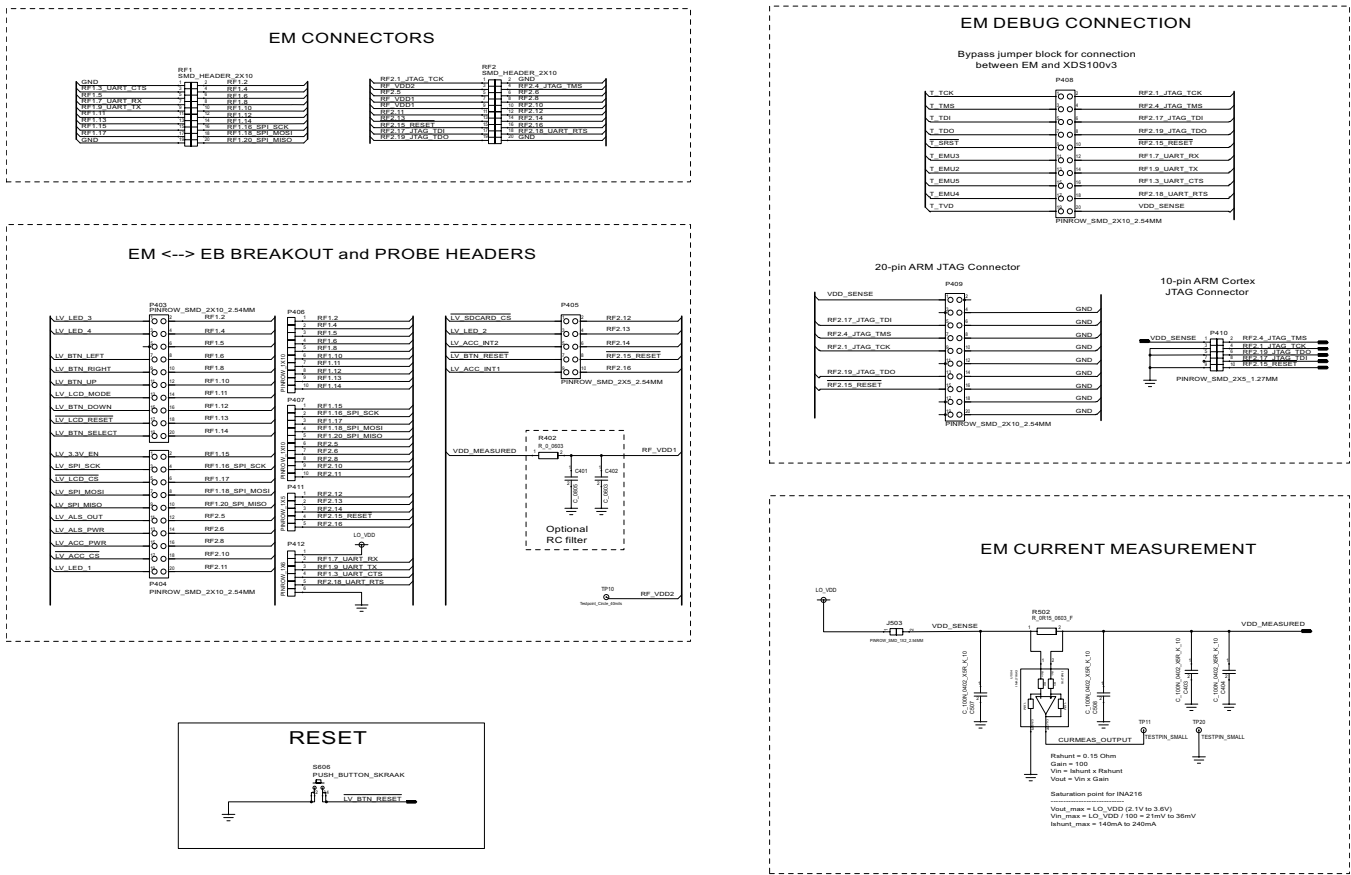

Copyright © 2017, Texas Instruments Incorporated

Figure 31. SmartRF06EB - EVM Interfaces/Level Shifters

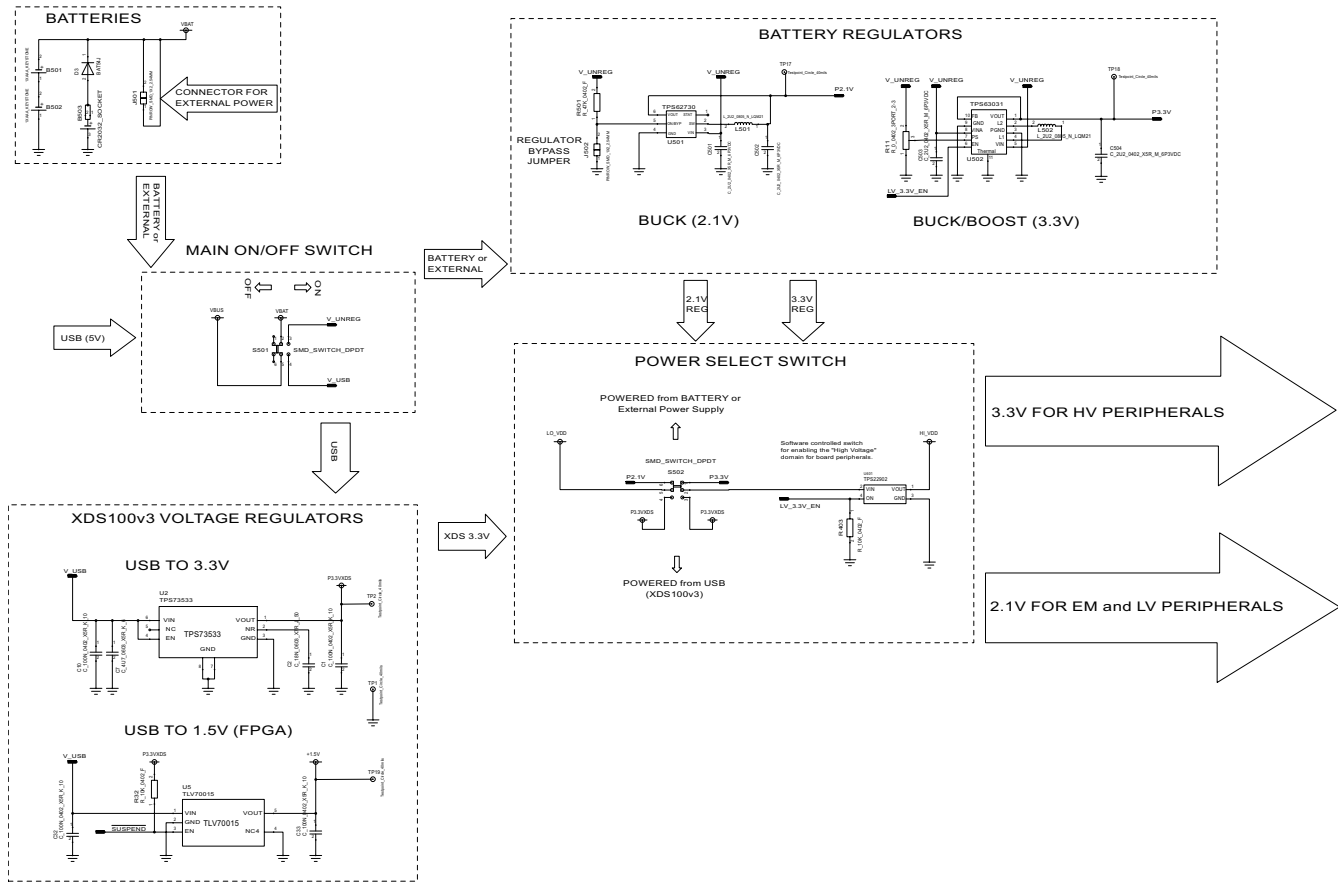

Copyright © 2017, Texas Instruments Incorporated

Figure 32. SmartRF06EB - Power Supply

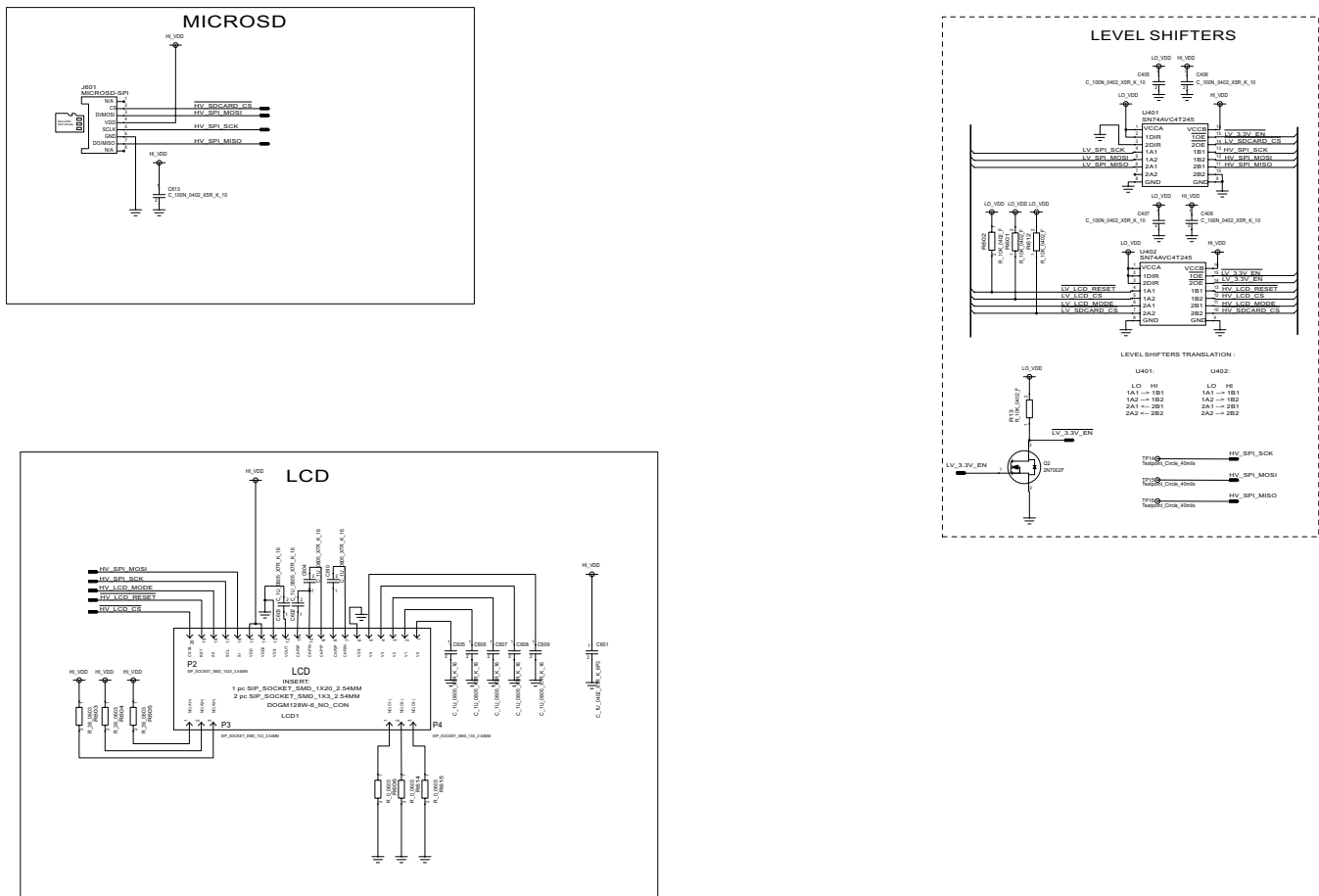

Copyright © 2017, Texas Instruments Incorporated

Figure 33. SmartRF06EB - High Voltage Peripheral

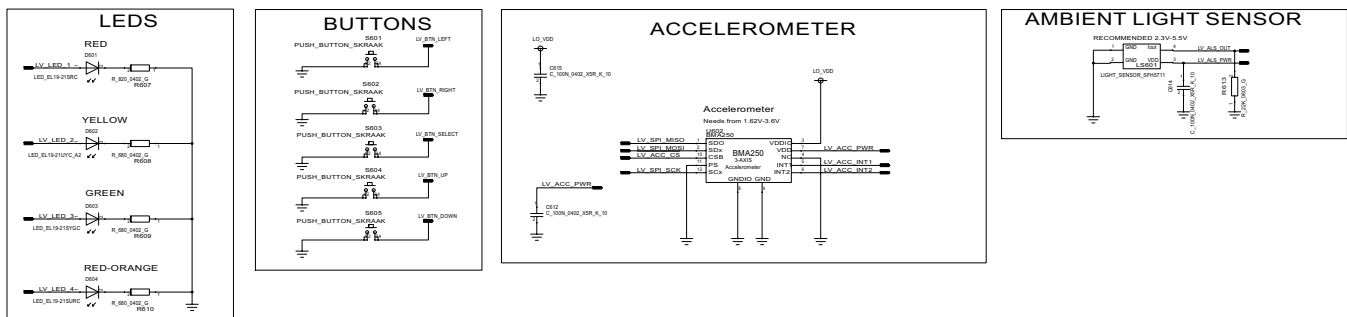

Copyright © 2017, Texas Instruments Incorporated

Figure 34. SmartRF06EB - Low Voltage Peripherals

Revision History

NOTE: Page numbers for previous revisions may differ from page numbers in the current version.

Changes from A Revision (May 2012) to B Revision	Page
• Added note of change in accelerometer.....	5

STANDARD TERMS FOR EVALUATION MODULES

1. *Delivery:* TI delivers TI evaluation boards, kits, or modules, including any accompanying demonstration software, components, and/or documentation which may be provided together or separately (collectively, an "EVM" or "EVMs") to the User ("User") in accordance with the terms set forth herein. User's acceptance of the EVM is expressly subject to the following terms.
 - 1.1 EVMs are intended solely for product or software developers for use in a research and development setting to facilitate feasibility evaluation, experimentation, or scientific analysis of TI semiconductor products. EVMs have no direct function and are not finished products. EVMs shall not be directly or indirectly assembled as a part or subassembly in any finished product. For clarification, any software or software tools provided with the EVM ("Software") shall not be subject to the terms and conditions set forth herein but rather shall be subject to the applicable terms that accompany such Software
 - 1.2 EVMs are not intended for consumer or household use. EVMs may not be sold, sublicensed, leased, rented, loaned, assigned, or otherwise distributed for commercial purposes by Users, in whole or in part, or used in any finished product or production system.
2. *Limited Warranty and Related Remedies/Disclaimers:*
 - 2.1 These terms do not apply to Software. The warranty, if any, for Software is covered in the applicable Software License Agreement.
 - 2.2 TI warrants that the TI EVM will conform to TI's published specifications for ninety (90) days after the date TI delivers such EVM to User. Notwithstanding the foregoing, TI shall not be liable for a nonconforming EVM if (a) the nonconformity was caused by neglect, misuse or mistreatment by an entity other than TI, including improper installation or testing, or for any EVMs that have been altered or modified in any way by an entity other than TI, (b) the nonconformity resulted from User's design, specifications or instructions for such EVMs or improper system design, or (c) User has not paid on time. Testing and other quality control techniques are used to the extent TI deems necessary. TI does not test all parameters of each EVM. User's claims against TI under this Section 2 are void if User fails to notify TI of any apparent defects in the EVMs within ten (10) business days after delivery, or of any hidden defects with ten (10) business days after the defect has been detected.
 - 2.3 TI's sole liability shall be at its option to repair or replace EVMs that fail to conform to the warranty set forth above, or credit User's account for such EVM. TI's liability under this warranty shall be limited to EVMs that are returned during the warranty period to the address designated by TI and that are determined by TI not to conform to such warranty. If TI elects to repair or replace such EVM, TI shall have a reasonable time to repair such EVM or provide replacements. Repaired EVMs shall be warranted for the remainder of the original warranty period. Replaced EVMs shall be warranted for a new full ninety (90) day warranty period.
3. *Regulatory Notices:*
 - 3.1 *United States*
 - 3.1.1 *Notice applicable to EVMs not FCC-Approved:*

FCC NOTICE: This kit is designed to allow product developers to evaluate electronic components, circuitry, or software associated with the kit to determine whether to incorporate such items in a finished product and software developers to write software applications for use with the end product. This kit is not a finished product and when assembled may not be resold or otherwise marketed unless all required FCC equipment authorizations are first obtained. Operation is subject to the condition that this product not cause harmful interference to licensed radio stations and that this product accept harmful interference. Unless the assembled kit is designed to operate under part 15, part 18 or part 95 of this chapter, the operator of the kit must operate under the authority of an FCC license holder or must secure an experimental authorization under part 5 of this chapter.
 - 3.1.2 *For EVMs annotated as FCC – FEDERAL COMMUNICATIONS COMMISSION Part 15 Compliant:*

CAUTION

This device complies with part 15 of the FCC Rules. Operation is subject to the following two conditions: (1) This device may not cause harmful interference, and (2) this device must accept any interference received, including interference that may cause undesired operation.

Changes or modifications not expressly approved by the party responsible for compliance could void the user's authority to operate the equipment.

FCC Interference Statement for Class A EVM devices

NOTE: This equipment has been tested and found to comply with the limits for a Class A digital device, pursuant to part 15 of the FCC Rules. These limits are designed to provide reasonable protection against harmful interference when the equipment is operated in a commercial environment. This equipment generates, uses, and can radiate radio frequency energy and, if not installed and used in accordance with the instruction manual, may cause harmful interference to radio communications. Operation of this equipment in a residential area is likely to cause harmful interference in which case the user will be required to correct the interference at his own expense.

FCC Interference Statement for Class B EVM devices

NOTE: This equipment has been tested and found to comply with the limits for a Class B digital device, pursuant to part 15 of the FCC Rules. These limits are designed to provide reasonable protection against harmful interference in a residential installation. This equipment generates, uses and can radiate radio frequency energy and, if not installed and used in accordance with the instructions, may cause harmful interference to radio communications. However, there is no guarantee that interference will not occur in a particular installation. If this equipment does cause harmful interference to radio or television reception, which can be determined by turning the equipment off and on, the user is encouraged to try to correct the interference by one or more of the following measures:

- Reorient or relocate the receiving antenna.
- Increase the separation between the equipment and receiver.
- Connect the equipment into an outlet on a circuit different from that to which the receiver is connected.
- Consult the dealer or an experienced radio/TV technician for help.

3.2 Canada

3.2.1 For EVMs issued with an Industry Canada Certificate of Conformance to RSS-210 or RSS-247

Concerning EVMs Including Radio Transmitters:

This device complies with Industry Canada license-exempt RSSs. Operation is subject to the following two conditions:

(1) this device may not cause interference, and (2) this device must accept any interference, including interference that may cause undesired operation of the device.

Concernant les EVMs avec appareils radio:

Le présent appareil est conforme aux CNR d'Industrie Canada applicables aux appareils radio exempts de licence. L'exploitation est autorisée aux deux conditions suivantes: (1) l'appareil ne doit pas produire de brouillage, et (2) l'utilisateur de l'appareil doit accepter tout brouillage radioélectrique subi, même si le brouillage est susceptible d'en compromettre le fonctionnement.

Concerning EVMs Including Detachable Antennas:

Under Industry Canada regulations, this radio transmitter may only operate using an antenna of a type and maximum (or lesser) gain approved for the transmitter by Industry Canada. To reduce potential radio interference to other users, the antenna type and its gain should be so chosen that the equivalent isotropically radiated power (e.i.r.p.) is not more than that necessary for successful communication. This radio transmitter has been approved by Industry Canada to operate with the antenna types listed in the user guide with the maximum permissible gain and required antenna impedance for each antenna type indicated. Antenna types not included in this list, having a gain greater than the maximum gain indicated for that type, are strictly prohibited for use with this device.

Concernant les EVMs avec antennes détachables

Conformément à la réglementation d'Industrie Canada, le présent émetteur radio peut fonctionner avec une antenne d'un type et d'un gain maximal (ou inférieur) approuvé pour l'émetteur par Industrie Canada. Dans le but de réduire les risques de brouillage radioélectrique à l'intention des autres utilisateurs, il faut choisir le type d'antenne et son gain de sorte que la puissance isotrope rayonnée équivalente (p.i.r.e.) ne dépasse pas l'intensité nécessaire à l'établissement d'une communication satisfaisante. Le présent émetteur radio a été approuvé par Industrie Canada pour fonctionner avec les types d'antenne énumérés dans le manuel d'usage et ayant un gain admissible maximal et l'impédance requise pour chaque type d'antenne. Les types d'antenne non inclus dans cette liste, ou dont le gain est supérieur au gain maximal indiqué, sont strictement interdits pour l'exploitation de l'émetteur.

3.3 Japan

3.3.1 *Notice for EVMs delivered in Japan:* Please see http://www.tij.co.jp/lstds/ti_ja/general/eStore/notice_01.page 日本国内に輸入される評価用キット、ボードについては、次のところをご覧ください。
http://www.tij.co.jp/lstds/ti_ja/general/eStore/notice_01.page

3.3.2 *Notice for Users of EVMs Considered "Radio Frequency Products" in Japan:* EVMs entering Japan may not be certified by TI as conforming to Technical Regulations of Radio Law of Japan.

If User uses EVMs in Japan, not certified to Technical Regulations of Radio Law of Japan, User is required to follow the instructions set forth by Radio Law of Japan, which includes, but is not limited to, the instructions below with respect to EVMs (which for the avoidance of doubt are stated strictly for convenience and should be verified by User):

1. Use EVMs in a shielded room or any other test facility as defined in the notification #173 issued by Ministry of Internal Affairs and Communications on March 28, 2006, based on Sub-section 1.1 of Article 6 of the Ministry's Rule for Enforcement of Radio Law of Japan,
2. Use EVMs only after User obtains the license of Test Radio Station as provided in Radio Law of Japan with respect to EVMs, or
3. Use of EVMs only after User obtains the Technical Regulations Conformity Certification as provided in Radio Law of Japan with respect to EVMs. Also, do not transfer EVMs, unless User gives the same notice above to the transferee. Please note that if User does not follow the instructions above, User will be subject to penalties of Radio Law of Japan.

【無線電波を送信する製品の開発キットをお使いになる際の注意事項】 開発キットの中には技術基準適合証明を受けていないものがあります。技術適合証明を受けていないものご使用に際しては、電波法遵守のため、以下のいずれかの措置を取っていただく必要がありますのでご注意ください。

1. 電波法施行規則第6条第1項第1号に基づく平成18年3月28日総務省告示第173号で定められた電波暗室等の試験設備でご使用いただく。
2. 実験局の免許を取得後ご使用いただく。
3. 技術基準適合証明を取得後ご使用いただく。

なお、本製品は、上記の「ご使用にあたっての注意」を譲渡先、移転先に通知しない限り、譲渡、移転できないものとします。

上記を遵守頂けない場合は、電波法の罰則が適用される可能性があることをご留意ください。日本テキサス・インスツルメンツ株式会社
東京都新宿区西新宿 6 丁目 2 4 番 1 号
西新宿三井ビル

3.3.3 *Notice for EVMs for Power Line Communication:* Please see http://www.tij.co.jp/lstds/ti_ja/general/eStore/notice_02.page
電力線搬送波通信についての開発キットをお使いになる際の注意事項については、次のところをご覧ください。 http://www.tij.co.jp/lstds/ti_ja/general/eStore/notice_02.page

3.4 *European Union*

3.4.1 *For EVMs subject to EU Directive 2014/30/EU (Electromagnetic Compatibility Directive):*

This is a class A product intended for use in environments other than domestic environments that are connected to a low-voltage power-supply network that supplies buildings used for domestic purposes. In a domestic environment this product may cause radio interference in which case the user may be required to take adequate measures.

4 *EVM Use Restrictions and Warnings:*

4.1 EVMS ARE NOT FOR USE IN FUNCTIONAL SAFETY AND/OR SAFETY CRITICAL EVALUATIONS, INCLUDING BUT NOT LIMITED TO EVALUATIONS OF LIFE SUPPORT APPLICATIONS.

4.2 User must read and apply the user guide and other available documentation provided by TI regarding the EVM prior to handling or using the EVM, including without limitation any warning or restriction notices. The notices contain important safety information related to, for example, temperatures and voltages.

4.3 *Safety-Related Warnings and Restrictions:*

4.3.1 User shall operate the EVM within TI's recommended specifications and environmental considerations stated in the user guide, other available documentation provided by TI, and any other applicable requirements and employ reasonable and customary safeguards. Exceeding the specified performance ratings and specifications (including but not limited to input and output voltage, current, power, and environmental ranges) for the EVM may cause personal injury or death, or property damage. If there are questions concerning performance ratings and specifications, User should contact a TI field representative prior to connecting interface electronics including input power and intended loads. Any loads applied outside of the specified output range may also result in unintended and/or inaccurate operation and/or possible permanent damage to the EVM and/or interface electronics. Please consult the EVM user guide prior to connecting any load to the EVM output. If there is uncertainty as to the load specification, please contact a TI field representative. During normal operation, even with the inputs and outputs kept within the specified allowable ranges, some circuit components may have elevated case temperatures. These components include but are not limited to linear regulators, switching transistors, pass transistors, current sense resistors, and heat sinks, which can be identified using the information in the associated documentation. When working with the EVM, please be aware that the EVM may become very warm.

4.3.2 EVMs are intended solely for use by technically qualified, professional electronics experts who are familiar with the dangers and application risks associated with handling electrical mechanical components, systems, and subsystems. User assumes all responsibility and liability for proper and safe handling and use of the EVM by User or its employees, affiliates, contractors or designees. User assumes all responsibility and liability to ensure that any interfaces (electronic and/or mechanical) between the EVM and any human body are designed with suitable isolation and means to safely limit accessible leakage currents to minimize the risk of electrical shock hazard. User assumes all responsibility and liability for any improper or unsafe handling or use of the EVM by User or its employees, affiliates, contractors or designees.

4.4 User assumes all responsibility and liability to determine whether the EVM is subject to any applicable international, federal, state, or local laws and regulations related to User's handling and use of the EVM and, if applicable, User assumes all responsibility and liability for compliance in all respects with such laws and regulations. User assumes all responsibility and liability for proper disposal and recycling of the EVM consistent with all applicable international, federal, state, and local requirements.

5. *Accuracy of Information:* To the extent TI provides information on the availability and function of EVMs, TI attempts to be as accurate as possible. However, TI does not warrant the accuracy of EVM descriptions, EVM availability or other information on its websites as accurate, complete, reliable, current, or error-free.

6. *Disclaimers:*

6.1 EXCEPT AS SET FORTH ABOVE, EVMS AND ANY MATERIALS PROVIDED WITH THE EVM (INCLUDING, BUT NOT LIMITED TO, REFERENCE DESIGNS AND THE DESIGN OF THE EVM ITSELF) ARE PROVIDED "AS IS" AND "WITH ALL FAULTS." TI DISCLAIMS ALL OTHER WARRANTIES, EXPRESS OR IMPLIED, REGARDING SUCH ITEMS, INCLUDING BUT NOT LIMITED TO ANY EPIDEMIC FAILURE WARRANTY OR IMPLIED WARRANTIES OF MERCHANTABILITY OR FITNESS FOR A PARTICULAR PURPOSE OR NON-INFRINGEMENT OF ANY THIRD PARTY PATENTS, COPYRIGHTS, TRADE SECRETS OR OTHER INTELLECTUAL PROPERTY RIGHTS.

6.2 EXCEPT FOR THE LIMITED RIGHT TO USE THE EVM SET FORTH HEREIN, NOTHING IN THESE TERMS SHALL BE CONSTRUED AS GRANTING OR CONFERRING ANY RIGHTS BY LICENSE, PATENT, OR ANY OTHER INDUSTRIAL OR INTELLECTUAL PROPERTY RIGHT OF TI, ITS SUPPLIERS/LICENSORS OR ANY OTHER THIRD PARTY, TO USE THE EVM IN ANY FINISHED END-USER OR READY-TO-USE FINAL PRODUCT, OR FOR ANY INVENTION, DISCOVERY OR IMPROVEMENT, REGARDLESS OF WHEN MADE, CONCEIVED OR ACQUIRED.

7. *USER'S INDEMNITY OBLIGATIONS AND REPRESENTATIONS.* USER WILL DEFEND, INDEMNIFY AND HOLD TI, ITS LICENSORS AND THEIR REPRESENTATIVES HARMLESS FROM AND AGAINST ANY AND ALL CLAIMS, DAMAGES, LOSSES, EXPENSES, COSTS AND LIABILITIES (COLLECTIVELY, "CLAIMS") ARISING OUT OF OR IN CONNECTION WITH ANY HANDLING OR USE OF THE EVM THAT IS NOT IN ACCORDANCE WITH THESE TERMS. THIS OBLIGATION SHALL APPLY WHETHER CLAIMS ARISE UNDER STATUTE, REGULATION, OR THE LAW OF TORT, CONTRACT OR ANY OTHER LEGAL THEORY, AND EVEN IF THE EVM FAILS TO PERFORM AS DESCRIBED OR EXPECTED.

8. *Limitations on Damages and Liability:*

8.1 *General Limitations.* IN NO EVENT SHALL TI BE LIABLE FOR ANY SPECIAL, COLLATERAL, INDIRECT, PUNITIVE, INCIDENTAL, CONSEQUENTIAL, OR EXEMPLARY DAMAGES IN CONNECTION WITH OR ARISING OUT OF THESE TERMS OR THE USE OF THE EVMS, REGARDLESS OF WHETHER TI HAS BEEN ADVISED OF THE POSSIBILITY OF SUCH DAMAGES. EXCLUDED DAMAGES INCLUDE, BUT ARE NOT LIMITED TO, COST OF REMOVAL OR REINSTALLATION, ANCILLARY COSTS TO THE PROCUREMENT OF SUBSTITUTE GOODS OR SERVICES, RETESTING, OUTSIDE COMPUTER TIME, LABOR COSTS, LOSS OF GOODWILL, LOSS OF PROFITS, LOSS OF SAVINGS, LOSS OF USE, LOSS OF DATA, OR BUSINESS INTERRUPTION. NO CLAIM, SUIT OR ACTION SHALL BE BROUGHT AGAINST TI MORE THAN TWELVE (12) MONTHS AFTER THE EVENT THAT GAVE RISE TO THE CAUSE OF ACTION HAS OCCURRED.

8.2 *Specific Limitations.* IN NO EVENT SHALL TI'S AGGREGATE LIABILITY FROM ANY USE OF AN EVM PROVIDED HEREUNDER, INCLUDING FROM ANY WARRANTY, INDEMNITY OR OTHER OBLIGATION ARISING OUT OF OR IN CONNECTION WITH THESE TERMS, EXCEED THE TOTAL AMOUNT PAID TO TI BY USER FOR THE PARTICULAR EVM(S) AT ISSUE DURING THE PRIOR TWELVE (12) MONTHS WITH RESPECT TO WHICH LOSSES OR DAMAGES ARE CLAIMED. THE EXISTENCE OF MORE THAN ONE CLAIM SHALL NOT ENLARGE OR EXTEND THIS LIMIT.

9. *Return Policy.* Except as otherwise provided, TI does not offer any refunds, returns, or exchanges. Furthermore, no return of EVM(s) will be accepted if the package has been opened and no return of the EVM(s) will be accepted if they are damaged or otherwise not in a resalable condition. If User feels it has been incorrectly charged for the EVM(s) it ordered or that delivery violates the applicable order, User should contact TI. All refunds will be made in full within thirty (30) working days from the return of the components(s), excluding any postage or packaging costs.

10. *Governing Law:* These terms and conditions shall be governed by and interpreted in accordance with the laws of the State of Texas, without reference to conflict-of-laws principles. User agrees that non-exclusive jurisdiction for any dispute arising out of or relating to these terms and conditions lies within courts located in the State of Texas and consents to venue in Dallas County, Texas. Notwithstanding the foregoing, any judgment may be enforced in any United States or foreign court, and TI may seek injunctive relief in any United States or foreign court.

IMPORTANT NOTICE FOR TI DESIGN INFORMATION AND RESOURCES

Texas Instruments Incorporated ("TI") technical, application or other design advice, services or information, including, but not limited to, reference designs and materials relating to evaluation modules, (collectively, "TI Resources") are intended to assist designers who are developing applications that incorporate TI products; by downloading, accessing or using any particular TI Resource in any way, you (individually or, if you are acting on behalf of a company, your company) agree to use it solely for this purpose and subject to the terms of this Notice.

TI's provision of TI Resources does not expand or otherwise alter TI's applicable published warranties or warranty disclaimers for TI products, and no additional obligations or liabilities arise from TI providing such TI Resources. TI reserves the right to make corrections, enhancements, improvements and other changes to its TI Resources.

You understand and agree that you remain responsible for using your independent analysis, evaluation and judgment in designing your applications and that you have full and exclusive responsibility to assure the safety of your applications and compliance of your applications (and of all TI products used in or for your applications) with all applicable regulations, laws and other applicable requirements. You represent that, with respect to your applications, you have all the necessary expertise to create and implement safeguards that (1) anticipate dangerous consequences of failures, (2) monitor failures and their consequences, and (3) lessen the likelihood of failures that might cause harm and take appropriate actions. You agree that prior to using or distributing any applications that include TI products, you will thoroughly test such applications and the functionality of such TI products as used in such applications. TI has not conducted any testing other than that specifically described in the published documentation for a particular TI Resource.

You are authorized to use, copy and modify any individual TI Resource only in connection with the development of applications that include the TI product(s) identified in such TI Resource. NO OTHER LICENSE, EXPRESS OR IMPLIED, BY ESTOPPEL OR OTHERWISE TO ANY OTHER TI INTELLECTUAL PROPERTY RIGHT, AND NO LICENSE TO ANY TECHNOLOGY OR INTELLECTUAL PROPERTY RIGHT OF TI OR ANY THIRD PARTY IS GRANTED HEREIN, including but not limited to any patent right, copyright, mask work right, or other intellectual property right relating to any combination, machine, or process in which TI products or services are used. Information regarding or referencing third-party products or services does not constitute a license to use such products or services, or a warranty or endorsement thereof. Use of TI Resources may require a license from a third party under the patents or other intellectual property of the third party, or a license from TI under the patents or other intellectual property of TI.

TI RESOURCES ARE PROVIDED "AS IS" AND WITH ALL FAULTS. TI DISCLAIMS ALL OTHER WARRANTIES OR REPRESENTATIONS, EXPRESS OR IMPLIED, REGARDING TI RESOURCES OR USE THEREOF, INCLUDING BUT NOT LIMITED TO ACCURACY OR COMPLETENESS, TITLE, ANY EPIDEMIC FAILURE WARRANTY AND ANY IMPLIED WARRANTIES OF MERCHANTABILITY, FITNESS FOR A PARTICULAR PURPOSE, AND NON-INFRINGEMENT OF ANY THIRD PARTY INTELLECTUAL PROPERTY RIGHTS.

TI SHALL NOT BE LIABLE FOR AND SHALL NOT DEFEND OR INDEMNIFY YOU AGAINST ANY CLAIM, INCLUDING BUT NOT LIMITED TO ANY INFRINGEMENT CLAIM THAT RELATES TO OR IS BASED ON ANY COMBINATION OF PRODUCTS EVEN IF DESCRIBED IN TI RESOURCES OR OTHERWISE. IN NO EVENT SHALL TI BE LIABLE FOR ANY ACTUAL, DIRECT, SPECIAL, COLLATERAL, INDIRECT, PUNITIVE, INCIDENTAL, CONSEQUENTIAL OR EXEMPLARY DAMAGES IN CONNECTION WITH OR ARISING OUT OF TI RESOURCES OR USE THEREOF, AND REGARDLESS OF WHETHER TI HAS BEEN ADVISED OF THE POSSIBILITY OF SUCH DAMAGES.

You agree to fully indemnify TI and its representatives against any damages, costs, losses, and/or liabilities arising out of your non-compliance with the terms and provisions of this Notice.

This Notice applies to TI Resources. Additional terms apply to the use and purchase of certain types of materials, TI products and services. These include; without limitation, TI's standard terms for semiconductor products (<http://www.ti.com/sc/docs/stdterms.htm>), [evaluation modules](#), and [samples](http://www.ti.com/sc/docs/sampterm.htm) (<http://www.ti.com/sc/docs/sampterm.htm>).

Mailing Address: Texas Instruments, Post Office Box 655303, Dallas, Texas 75265
Copyright © 2017, Texas Instruments Incorporated

Looking for pricing, stock, or lifecycle information?

Click below to explore more details on WIN SOURCE:

 [View SMARTRF06EBK](#) on WIN SOURCE

 [Texas Instruments](#) Information

Optimize Your Supply Chain with WIN SOURCE Solutions

-  Global Sourcing Solution
-  Obsolete Management
-  Cost Control Management
-  Shortage Management
-  Alternative Solution
-  Excess Inventory Management