

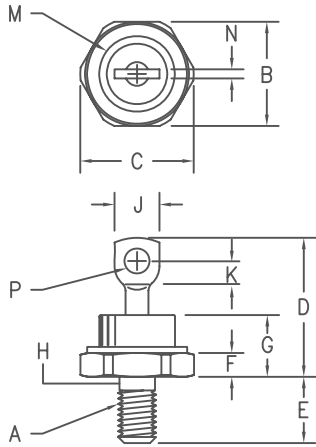

THE DATASHEET OF
S3460



Silicon Power Rectifier S/R34 Series



Notes:

1. Full threads within 2 1/2 threads
2. Standard Polarity: Stud is Cathode
Reverse Polarity: Stud is Anode

Dim.	Inches		Millimeter		Notes
	Minimum	Maximum	Minimum	Maximum	
A	---	---	---	---	1/4-28
B	.677	.687	17.19	17.44	
C	---	.793	---	20.14	
D	---	1.00	---	25.40	
E	.427	.447	10.84	11.35	
F	.115	.200	2.92	5.08	
G	---	.450	---	11.43	
H	.220	.249	5.59	6.32	1
J	---	.375	---	9.52	
K	.156	---	3.97	---	
M	---	.667	---	16.94	Dia
N	---	.080	---	2.03	
P	.140	.175	3.56	4.44	Dia

D0203AB (D05)

Microsemi
Catalog Number
Standard

*S3410
*S3420
*S3440
*S3460
*S3480
*S34100
*S34120
*S34140
*S34160

Peak Reverse
Voltage

100V
200V
400V
600V
800V
1000V
1200V
1400V
1600V

*Change S to R in part number for Reverse Polarity

- Glass Passivated Die
- 800A surge rating
- Glass to metal seal construction
- V_{RRM} to 1600V
- Low cost Non-RoHS package

Electrical Characteristics

Average forward current	$I_F(AV)$ 45 Amps	$T_C = 123^\circ C$, half sine wave, $R_{\theta JC} = 1.75^\circ C/W$ 8.3ms, half sine, $T_J = 200^\circ C$
Maximum surge current	I_{FSM} 800 Amps	
Max $I^2 t$ for fusing	$I^2 t$ 2600 A ² s	$I_{FM} = 90A; T_J = 25^\circ C$ $V_{RRM, T_J = 25^\circ C}$ $V_{RRM, T_J = 150^\circ C}$
Max peak forward voltage	V_{FM} 1.15 Volts	
Max peak reverse current	I_{RM} 10 μA	
Max peak reverse current	I_{RM} 2.0 mA	
Max Recommended Operating Frequency	10kHz	

*Pulse test: Pulse width 300 μ sec. Duty cycle 2%

Thermal and Mechanical Characteristics

Storage temperature range	T_{STG}	-65°C to 200°C
Operating junction temp range	T_J	-65°C to 200°C
Maximum thermal resistance	$R_{\theta JC}$	1.75°C/W Junction to Case
Mounting torque		25-30 inch pounds
Weight		.5 ounces (14 grams) typical

S/R34

Figure 1
Typical Forward Characteristics

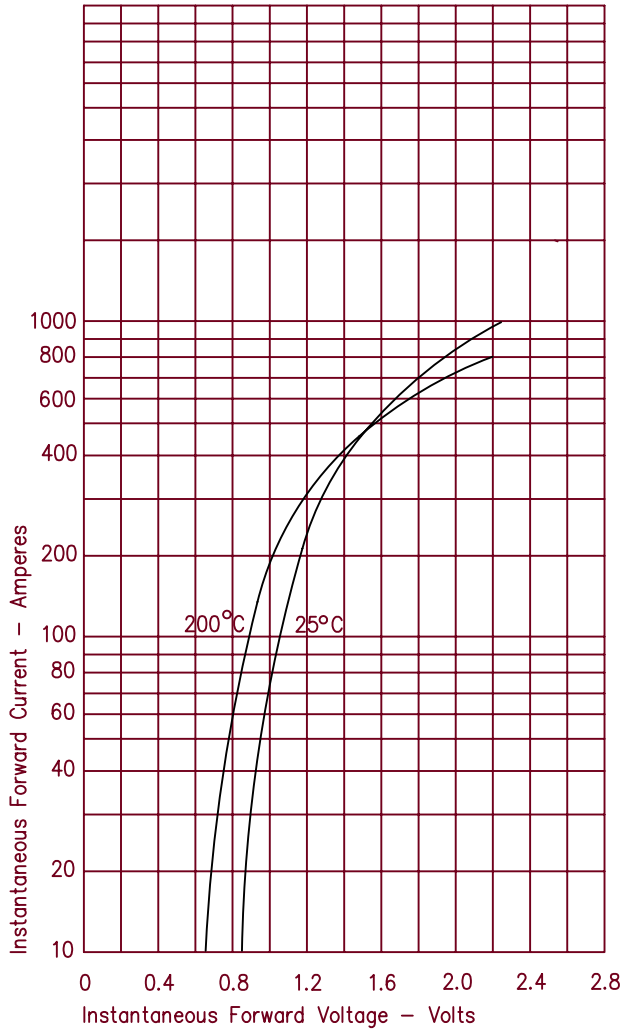

Figure 3
Forward Current Derating

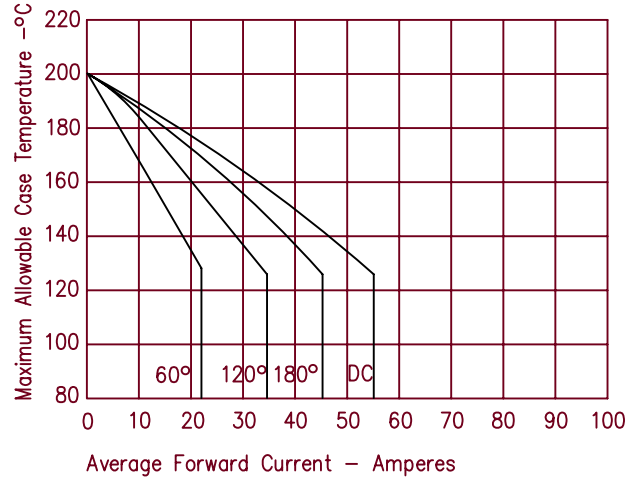

Figure 4
Maximum Forward Power Dissipation

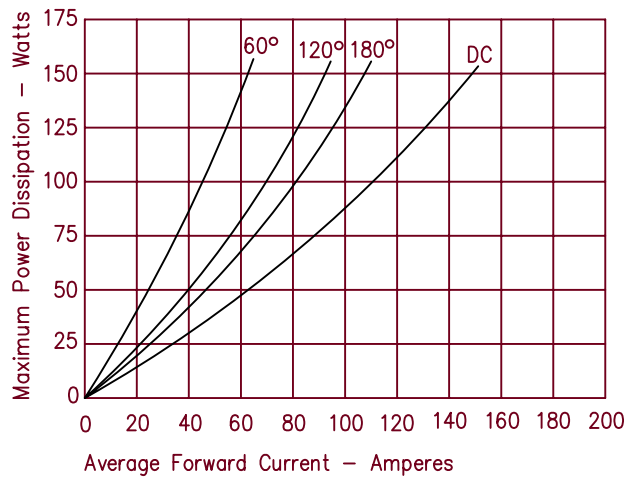
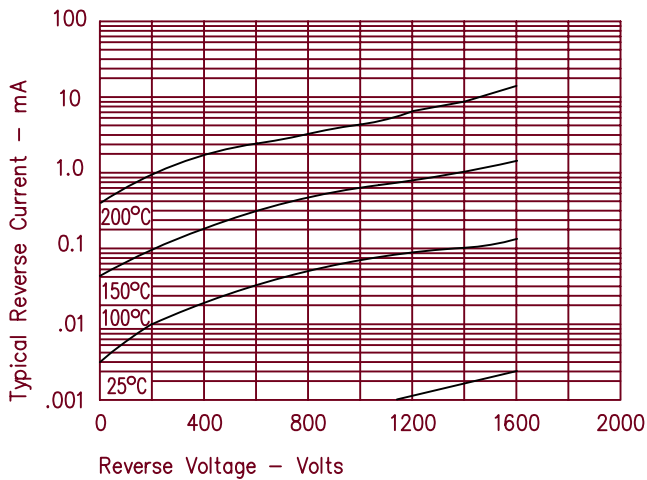



Figure 2
Typical Reverse Characteristics



Looking for pricing, stock, or lifecycle information?

Click below to explore more details on WIN SOURCE:

-  [View S3460 on WIN SOURCE](#)
-  [Microchip Technology](#) Information

Optimize Your Supply Chain with WIN SOURCE Solutions

-  Global Sourcing Solution
-  Obsolete Management
-  Cost Control Management
-  Shortage Management
-  Alternative Solution
-  Excess Inventory Management