



**THE DATASHEET OF
SMBJ5358AE3/TR13**



EMC OPTIMIZED CAN TRANSCEIVER

Check for Samples : [SN65HVD1050-EP](#)

FEATURES

- **Controlled Baseline**
 - One Assembly/Test Site, One Fabrication Site
- **Enhanced Diminishing Manufacturing Sources (DMS) Support**
- **Enhanced Product-Change Notification**
- **Qualification Pedigree ⁽¹⁾**
- **Improved Replacement for the TJA1050**
- **High Electromagnetic Immunity (EMI)**
- **Very Low Electromagnetic Emissions (EME)**
- **Meets or Exceeds the Requirements of ISO 11898-2**
- **Bus-Fault Protection of –27 V to 40 V**
- **Dominant Time-Out Function**
- **Thermal Shutdown Protection**
- **Power-Up/Down Glitch-Free Bus Inputs and Outputs**
 - High Input Impedance With Low V_{CC}
 - Monotonic Outputs During Power Cycling

APPLICATIONS

- **Industrial Automation**
 - DeviceNET™ Data Buses (Vendor ID #806)
- **SAE J2284 High-Speed CAN for Automotive Applications**
- **SAE J1939 Standard Data Bus Interface**
- **ISO 11783 Standard Data Bus Interface**
- **NMEA 2000 Standard Data Bus Interface**

(1) Component qualification in accordance with JEDEC and industry standards to ensure reliable operation over an extended temperature range. This includes, but is not limited to, Highly Accelerated Stress Test (HAST) or biased 85/85, temperature cycle, autoclave or unbiased HAST, electromigration, bond intermetallic life, and mold compound life. Such qualification testing should not be viewed as justifying use of this component beyond specified performance and environmental limits.

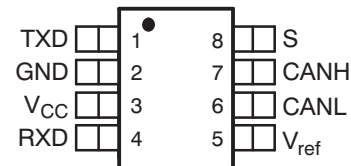
**D PACKAGE
(TOP VIEW)**

DESCRIPTION/ ORDERING INFORMATION

The SN65HVD1050 meets or exceeds the specifications of the ISO 11898 standard for use in applications employing a controller area network (CAN). The device is also qualified for use in automotive applications in accordance with AEC-Q100.⁽²⁾

As a CAN transceiver, this device provides differential transmit capability to the bus and differential receive capability to a CAN controller at signaling rates up to 1 megabit per second (Mbps)⁽³⁾.

Designed for operation in especially harsh environments, the SN65HVD1050 features cross-wire, overvoltage, and loss of ground protection from –27 V to 40 V, overtemperature protection, a –12-V to 12-V common-mode range, and withstands voltage transients from –200 V to 200 V, according to ISO 7637.

Pin 8 provides for two different modes of operation: high-speed or silent mode. The high-speed mode of operation is selected by connecting S (pin 8) to ground.

(2) The device is available with Q100 qualification as the SN65HVD1050Q (Product Preview).

(3) The signaling rate of a line is the number of voltage transitions that are made, per second, expressed in the units bps (bits per second).

ORDERING INFORMATION

PART NUMBER	PACKAGE	MARKED AS	ORDERING NUMBER
SN65HVD1050M	SOIC-8	1050EP	SN65HVD1050MDREP (reel)



Please be aware that an important notice concerning availability, standard warranty, and use in critical applications of Texas Instruments semiconductor products and disclaimers thereto appears at the end of this data sheet.

DeviceNET is a trademark of Open Devicenet Vendors Association, Inc.



This integrated circuit can be damaged by ESD. Texas Instruments recommends that all integrated circuits be handled with appropriate precautions. Failure to observe proper handling and installation procedures can cause damage.

ESD damage can range from subtle performance degradation to complete device failure. Precision integrated circuits may be more susceptible to damage because very small parametric changes could cause the device not to meet its published specifications.

DESCRIPTION/ORDERING INFORMATION (CONTINUED)

If a high logic level is applied to the S pin of the SN65HVD1050, the device enters a listen-only silent mode, during which the driver is switched off while the receiver remains fully functional.

In silent mode, all bus activity is passed by the receiver output to the local protocol controller. When data transmission is required, the local protocol controller reverses this low-current silent mode by placing a logic low on the S pin to resume full operation.

A dominant-time-out circuit in the SN65HVD1050 prevents the driver from blocking network communication with a hardware or software failure. The time-out circuit is triggered by a falling edge on TXD (pin 1). If no rising edge is seen before the time-out constant of the circuit expires, the driver is disabled. The circuit is then reset by the next rising edge on TXD.

V_{ref} (pin 5) is available as a $V_{CC}/2$ voltage reference.

The SN65HVD1050M is characterized for operation from -55°C to 125°C .

FUNCTION BLOCK DIAGRAM

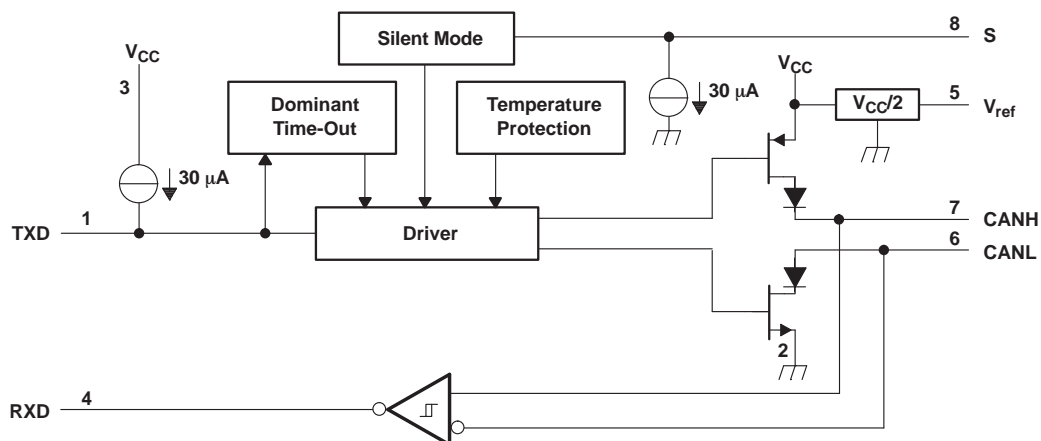

Absolute Maximum Ratings⁽¹⁾

	UNIT
V_{CC} Supply voltage ⁽²⁾	-0.3 V to 7 V
Voltage range at any bus terminal (CANH, CANL, V_{ref})	-27 V to 40 V
I_O Receiver output current	20 mA
V_I Voltage input, transient pulse ⁽³⁾ (CANH, CANL)	-200 V to 200 V
V_I Voltage input range (TXD, S)	-0.5 V to 6 V
T_J Junction temperature	-55°C to 170°C

- (1) Stresses beyond those listed under "absolute maximum ratings" may cause permanent damage to the device. These are stress ratings only, and functional operation of the device at these or any other conditions beyond those indicated under "recommended operating conditions" is not implied. Exposure to absolute-maximum-rated conditions for extended periods may affect device reliability.
- (2) All voltage values, except differential I/O bus voltages, are with respect to network ground terminal.
- (3) Tested in accordance with ISO 7637, test pulses 1, 2, 3a, 3b, 5, 6, and 7

Electrostatic Discharge Protection

over operating free-air temperature range (unless otherwise noted)

PARAMETER	TEST CONDITIONS		UNIT
Electrostatic discharge ⁽¹⁾	Human-Body Model ⁽²⁾	Bus terminals and GND	±8 kV
		All pins	±4 kV
	Charged-Device Model ⁽³⁾	All pins	±1.5 kV
		Machine Model	±200 V

(1) All typical values at 25°C

(2) Tested in accordance with JEDEC Standard 22, Test Method A114-A

(3) Tested in accordance with JEDEC Standard 22, Test Method C101

Recommended Operating Conditions

			MIN	MAX	UNIT
V_{CC}	Supply voltage		4.75	5.25	V
V_I or V_{IC}	Voltage at any bus terminal (separately or common mode)		-12	12	V
V_{IH}	High-level input voltage	TXD, S	2	5.25	V
V_{IL}	Low-level input voltage	TXD, S	0	0.8	V
V_{ID}	Differential input voltage		-6	6	V
I_{OH}	High-level output current	Driver	-70		mA
		Receiver	-2		
I_{OL}	Low-level output current	Driver		70	mA
		Receiver		2	
T_J	Junction temperature	See Thermal Characteristics table, 1-Mbps minimum signaling rate with $R_L = 54 \Omega$		150	°C

Supply Current

over recommended operating conditions (unless otherwise noted)

PARAMETER		TEST CONDITIONS	MIN	TYP	MAX	UNIT
I_{CC}	5-V supply current	Silent mode		6	10	mA
		Dominant	$V_I = 0 \text{ V}$, 60- Ω load, S at 0 V	50	70	
		Recessive	$V_I = V_{CC}$, No load, S at 0 V	6	10	

Device Switching Characteristics

over operating free-air temperature range (unless otherwise noted)

PARAMETER		TEST CONDITIONS	MIN	MAX	UNIT
$t_{d(LOOP1)}$	Total loop delay, driver input to receiver output, recessive to dominant	S at 0 V, See Figure 9	90	230	ns
$t_{d(LOOP2)}$	Total loop delay, driver input to receiver output, dominant to recessive		90	230	

Driver Electrical Characteristics

over recommended operating conditions (unless otherwise noted)

PARAMETER		TEST CONDITIONS	MIN	TYP (1)	MAX	UNIT
V _{O(D)}	Bus output voltage (dominant)	CANH	2.9	3.4	4.5	V
		CANL				
		V _I = 0 V, S at 0 V, R _L = 60 Ω, See Figure 1 and Figure 2				
V _{O(R)}	Bus output voltage (recessive)	V _I = 3 V, S at 0 V, R _L = 60 Ω, See Figure 1 and Figure 2	2	2.3	3	V
V _{OD(D)}	Differential output voltage (dominant)	V _I = 0 V, R _L = 60 Ω, S at 0 V, See Figure 1 , Figure 2 , and Figure 3	1.5		3	V
		V _I = 0 V, R _L = 45 Ω, S at 0 V, See Figure 1 , Figure 2 , and Figure 3	1.4		3	
V _{OD(R)}	Differential output voltage (recessive)	V _I = 3 V, S at 0 V, See Figure 1 and Figure 2	-0.012		0.012	V
		V _I = 3 V, S at 0 V, No load	-0.5		0.05	
V _{OC(ss)}	Steady-state common-mode output voltage	S at 0 V, See Figure 8	2	2.3	3	V
ΔV _{OC(ss)}	Change in steady-state common-mode output voltage			30		mV
I _{IH}	High-level input current, TXD input	V _I at V _{CC}	-2		2	μA
I _{IL}	Low-level input current, TXD input	V _I at 0 V	-50		-10	
I _{O(off)}	Power-off TXD output current	V _{CC} at 0 V, TXD at 5 V			1	
I _{OS(ss)}	Short-circuit steady-state output current	V _{CANH} = -12 V, CANL open, See Figure 11	-105	-72		mA
		V _{CANH} = 12 V, CANL open, See Figure 11		0.36	1	
		V _{CANL} = -12 V, CANH open, See Figure 11	-1	-0.5		
		V _{CANL} = 12 V, CANH open, See Figure 11		71	105	
C _O	Output capacitance	See receiver input capacitance				

(1) All typical values are at 25°C, with a 5-V supply.

Driver Switching Characteristics

over recommended operating conditions (unless otherwise noted)

PARAMETER		TEST CONDITIONS	MIN	TYP	MAX	UNIT
t _{PLH}	Propagation delay time, low- to high-level output	S at 0 V, See Figure 4	25	65	120	ns
t _{PHL}	Propagation delay time, high- to low-level output		25	45	120	
t _r	Differential output signal rise time	S at 0 V, See Figure 4		25		ns
t _f	Differential output signal fall time			50		
t _{en}	Enable time from silent mode to dominant	See Figure 7			1	μs
t _(dom)	Dominant time-out	↓V _I , See Figure 10	300	450	700	μs

Receiver Electrical Characteristics

over recommended operating conditions (unless otherwise noted)

PARAMETER		TEST CONDITIONS	MIN	TYP ⁽¹⁾	MAX	UNIT
V _{IT+}	Positive-going input threshold voltage	S at 0 V, See Table 3		800	900	mV
V _{IT-}	Negative-going input threshold voltage	S at 0 V, See Table 3	500	650		mV
V _{hys}	Hysteresis voltage (V _{IT+} – V _{IT-})		100	125		mV
V _{OH}	High-level output voltage	I _O = –2 mA, See Figure 6	4	4.6		V
V _{OL}	Low-level output voltage	I _O = 2 mA, See Figure 6		0.2	0.4	V
I _{I(off)}	Power-off bus input current	CANH or CANL = 5 V, Other pin at 0 V, V _{CC} at 0 V, TXD at 0 V		165	250	μA
I _{O(off)}	Power-off RXD leakage current	V _{CC} at 0 V, RXD at 5 V			20	μA
C _I	Input capacitance to ground (CANH or CANL)	TXD at 3 V, V _I = 0.4 sin(4E6πt) + 2.5 V		13		pF
C _{ID}	Differential input capacitance	TXD at 3 V, V _I = 0.4 sin(4E6πt)		5		pF
R _{ID}	Differential input resistance	TXD at 3 V, S at 0 V	30		80	kΩ
R _{IN}	Input resistance (CANH or CANL)	TXD at 3 V, S at 0 V	15	30	40	kΩ
R _{I(m)}	Input resistance matching [1 – (R _{IN (CANH)} / R _{IN (CANL)})] × 100%	V _{O(CANH)} = V _{O(CANL)}	–3%	0%	3%	

(1) All typical values are at 25 °C with a 5-V supply.

Receiver Switching Characteristics

over recommended operating conditions (unless otherwise noted)

PARAMETER		TEST CONDITIONS	MIN	TYP	MAX	UNIT
t _{PLH}	Propagation delay time, low- to high-level output	S at 0 V or V _{CC} , See Figure 6	60	100	130	ns
t _{PHL}	Propagation delay time, high- to low-level output		45	70	130	
t _r	Output signal rise time	S at 0 V or V _{CC} , See Figure 6		8		ns
t _f	Output signal fall time			8		

S-Pin Characteristics

over recommended operating conditions (unless otherwise noted)

PARAMETER		TEST CONDITIONS	MIN	TYP	MAX	UNIT
I _{IH}	High-level input current	S at 2 V	20	40	70	μA
I _{IL}	Low-level input current	S at 0.8 V	5	20	30	μA

V_{ref}-PIN Characteristics

over operating free-air temperature range (unless otherwise noted)

PARAMETER		TEST CONDITIONS	MIN	TYP	MAX	UNIT
V _O	Reference output voltage	–50 μA < I _O < 50 μA	0.4 V _{CC}	0.5 V _{CC}	0.6 V _{CC}	V

Thermal Characteristics

over operating free-air temperature range (unless otherwise noted)

PARAMETER		TEST CONDITIONS	MIN	TYP	MAX	UNIT
θ _{JA}	Junction to Air	Low-K thermal resistance ⁽¹⁾		211		°C/W
		High-K thermal resistance		131		
θ _{JB}	Junction-to-board thermal resistance			53		°C/W
θ _{JC}	Junction-to-case thermal resistance			79		°C/W

(1) Tested in accordance with the Low-K or High-K thermal metric definitions of EIA/JESD51-3 for leaded surface-mount packages

Thermal Characteristics (continued)

over operating free-air temperature range (unless otherwise noted)

PARAMETER	TEST CONDITIONS	MIN	TYP	MAX	UNIT
P _D Average power dissipation	V _{CC} = 5 V, T _J = 27°C, R _L = 60 Ω, S at 0 V, Input to TXD a 500-kHz, 50% duty-cycle square wave, C _L at RXD = 15 pF		112		mW
	V _{CC} = 5.5 V, T _J = 130°C, R _L = 45 Ω, S at 0 V, Input to TXD a 500-kHz, 50% duty-cycle square wave, C _L at RXD = 15 pF			170	
Thermal shutdown temperature			190		°C

FUNCTION TABLES
Table 1. DRIVER

INPUTS		OUTPUTS		BUS STATE
TXD ⁽¹⁾	S ⁽¹⁾	CANH ⁽¹⁾	CANL ⁽¹⁾	
L	L or Open	H	L	Dominant
H	X	Z	Z	Recessive
Open	X	Z	Z	Recessive
X	H	Z	Z	Recessive

(1) H = high level, L = low level, X = irrelevant, Z = high impedance

Table 2. RECEIVER

DIFFERENTIAL INPUTS V _{ID} = V _(CANH) – V _(CANL)	OUTPUT RXD ⁽¹⁾	BUS STATE
V _{ID} ≥ 0.9 V	L	Dominant
0.5 V < V _{ID} < 0.9 V	?	?
V _{ID} ≤ 0.5 V	H	Recessive
Open	H	Recessive

(1) H = high level, L = low level, X = irrelevant, ? = indeterminate

PARAMETER MEASUREMENT INFORMATION

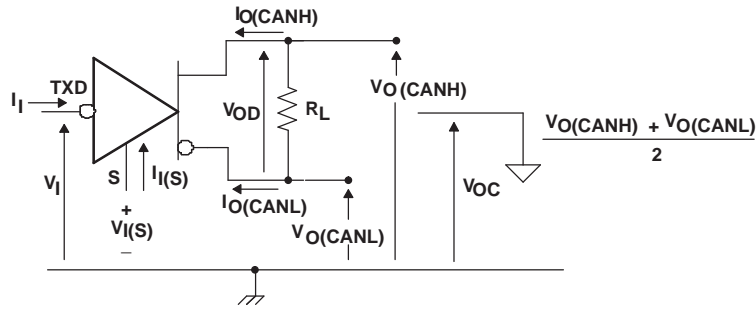

Figure 1. Driver Voltage, Current, and Test Definition

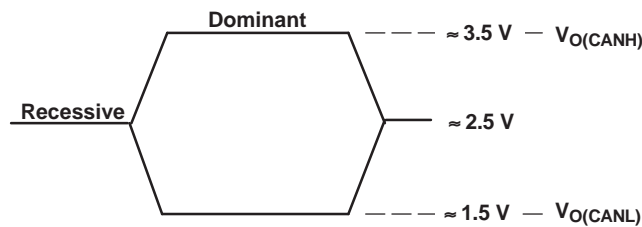

Figure 2. Bus Logic State Voltage Definitions

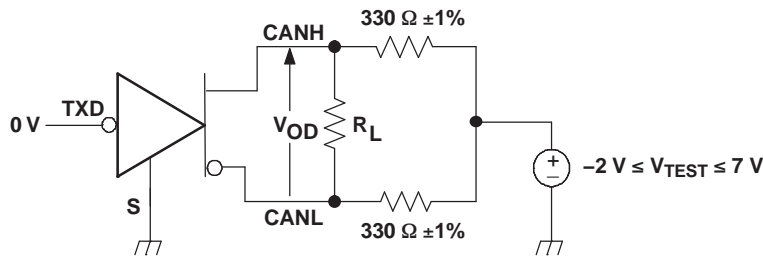

Figure 3. Driver VOD Test Circuit

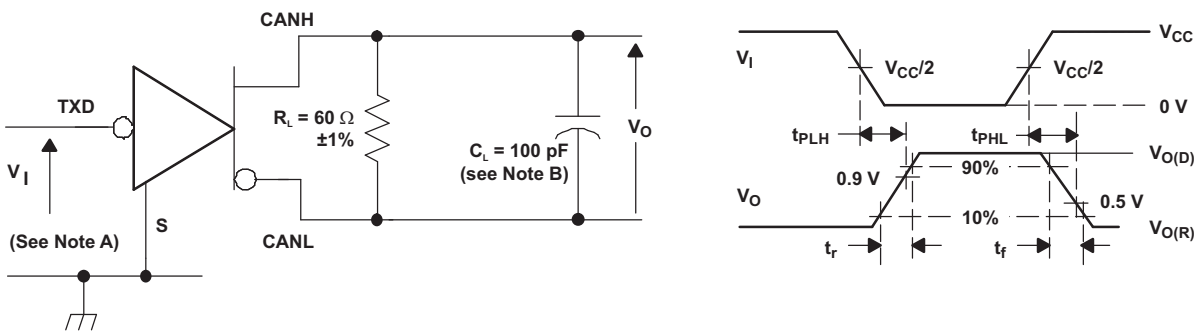

Figure 4. Driver Test Circuit and Voltage Waveforms

PARAMETER MEASUREMENT INFORMATION (continued)

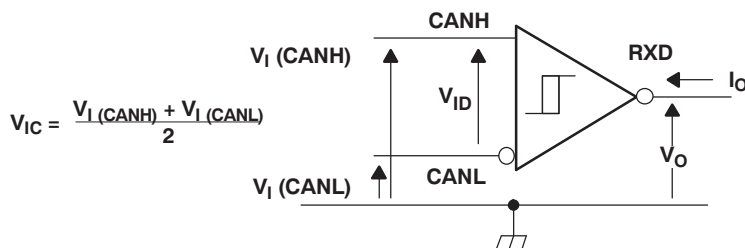
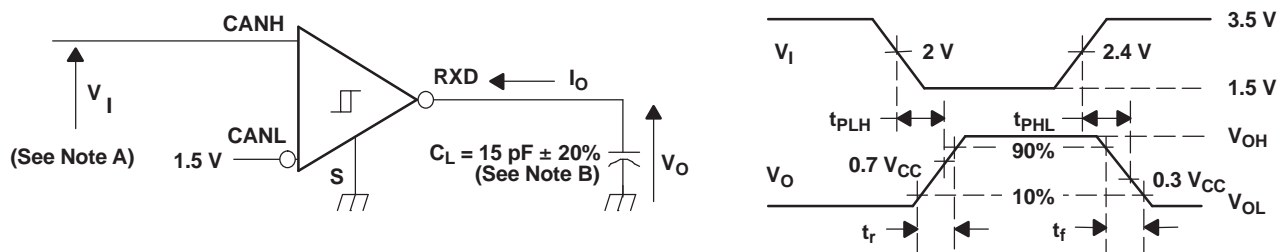

Figure 5. Receiver Voltage and Current Definitions



- A. The input pulse is supplied by a generator having the following characteristics: PRR ≤ 125 kHz, 50% duty cycle, t_r ≤ 6 ns, t_f ≤ 6 ns, Z_O = 50 Ω.
- B. C_L includes instrumentation and fixture capacitance within ±20%.

Figure 6. Receiver Test Circuit and Voltage Waveforms

Table 3. Differential Input Voltage Threshold Test

INPUT			OUTPUT	
V _{CANH}	V _{CANL}	V _{ID}	R	
-11.1 V	-12 V	900 mV	L	V _{OL}
12 V	11.1 V	900 mV	L	
-6 V	-12 V	6 V	L	
12 V	6 V	6 V	L	
-11.5 V	-12 V	500 mV	H	V _{OH}
12 V	11.5 V	500 mV	H	
-12 V	-6 V	6 V	H	
6 V	12 V	6 V	H	
Open	Open	X	H	

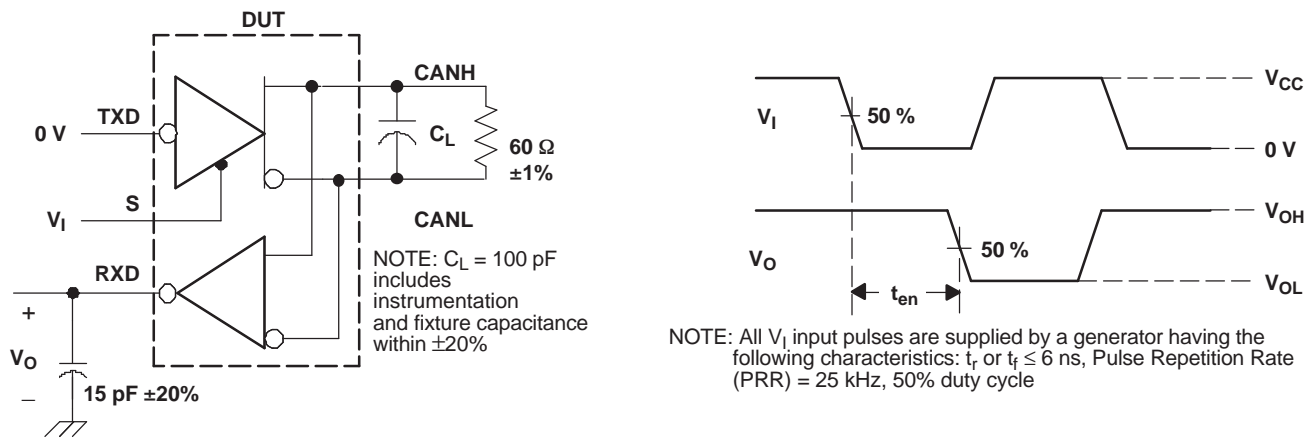
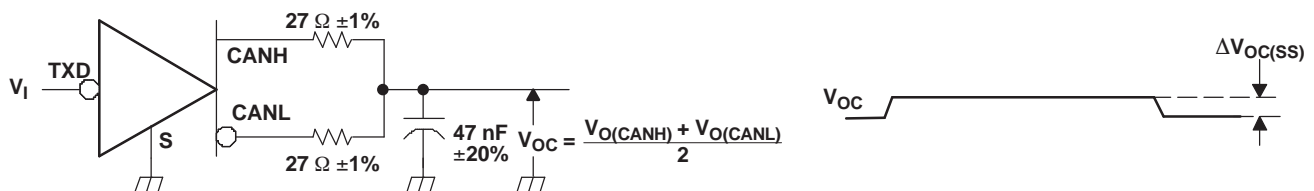
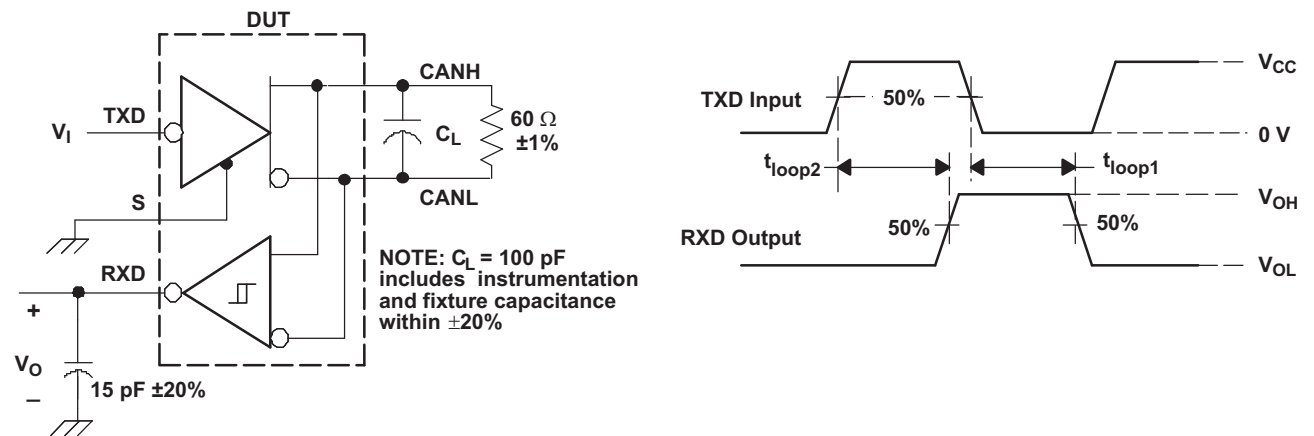

Figure 7. t_{en} Test Circuit and Waveforms



NOTE: All V_I input pulses are from 0 V to V_{CC} and supplied by a generator having the following characteristics: t_r or $t_f \leq 6 \text{ ns}$. Pulse Repetition Rate (PRR) = 125 kHz, 50% duty cycle.

Figure 8. Common-Mode Output Voltage Test and Waveform



A. All V_I input pulses are from 0 V to V_{CC} and supplied by a generator having the following characteristics: t_r or $t_f \leq 6 \text{ ns}$. Pulse Repetition Rate (PRR) = 125 kHz, 50% duty cycle.

Figure 9. $t_{(LOOP)}$ Test Circuit and Waveform

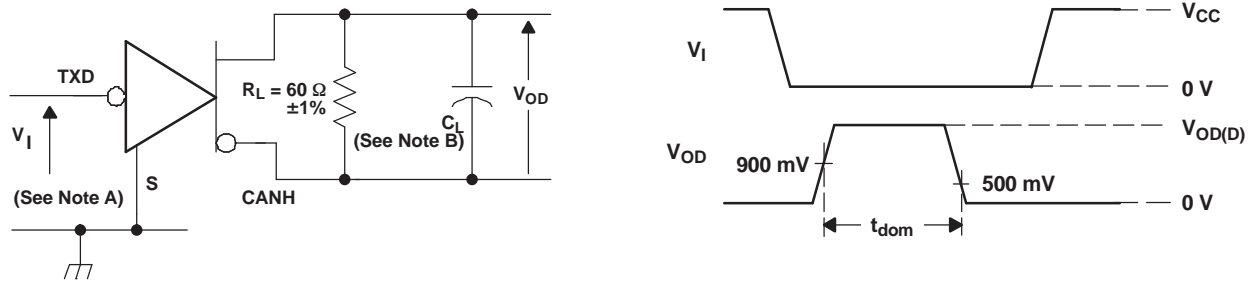

- A. All V_I input pulses are from 0 V to V_{CC} and supplied by a generator having the following characteristics: t_r or $t_f \leq 6$ ns. Pulse Repetition Rate (PRR) = 500 Hz, 50% duty cycle.
- B. $C_L = 100$ pF includes instrumentation and fixture capacitance within $\pm 20\%$.

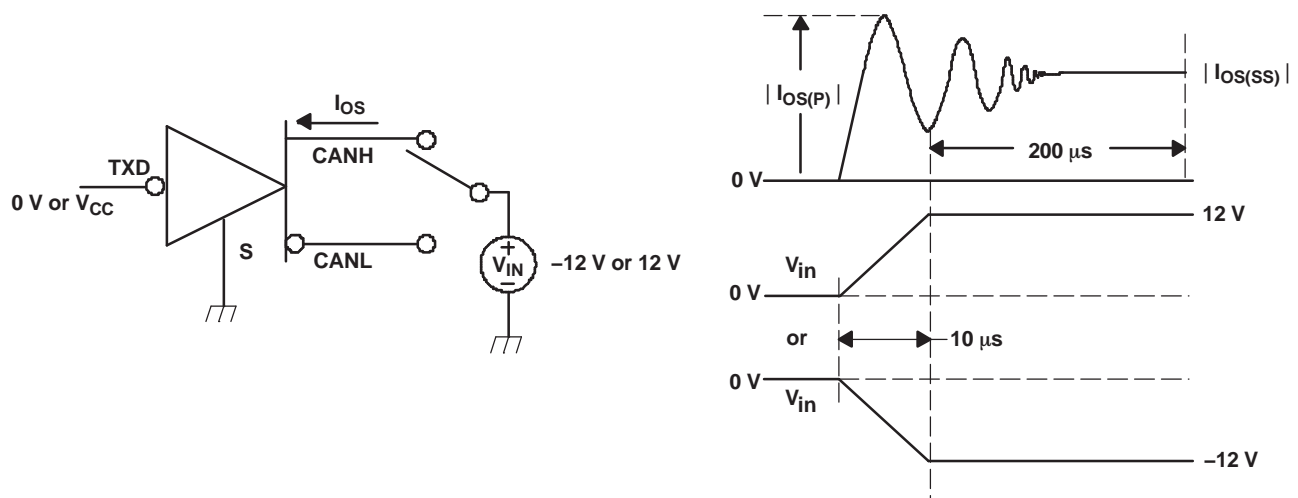
Figure 10. Dominant Time-Out Test Circuit and Waveforms

Figure 11. Driver Short-Circuit Current Test and Waveforms

DEVICE INFORMATION
Table 4. Parametric Cross-Reference With the TJA1050

TJA1050 ⁽¹⁾	PARAMETER	HVD1050
Transmitter Section		
V _{IH}	High-level input voltage	Recommended V _{IH}
V _{IL}	Low-level input voltage	Recommended V _{IL}
I _{IH}	High-level input current	Driver I _{IH}
I _{IL}	Low-level input current	Driver I _{IL}
Bus Section		
I _{LI}	Power-off bus input current	Receiver I _{I(off)}
I _{O(SC)}	Short-circuit output current	Driver I _{OS(SS)}
V _{O(dom)}	Dominant output voltage	Driver V _{O(D)}
V _{i(dif)(th)}	Differential input voltage	Receiver V _{IT} and recommended V _{ID}
V _{i(dif)(hys)}	Differential input hysteresis	Receiver V _{hys}
V _{O(reces)}	Recessive output voltage	Driver V _{O(R)}
V _{O(dif)(bus)}	Differential bus voltage	Driver V _{OD(D)} and V _{OD(R)}
R _{i(cm)}	CANH, CANL input resistance	Receiver R _{IN}
R _{i(dif)}	Differential input resistance	Receiver R _{ID}
R _{i(cm) (m)}	Input resistance matching	Receiver R _{I (m)}
C _I	Input capacitance to ground	Receiver C _I
C _{i(dif)}	Differential input capacitance	Receiver C _{ID}
Receiver Section		
I _{OH}	High-level output current	Recommended I _{OH}
I _{OL}	Low-level output current	Recommended I _{OL}
V_{ref}-Pin Section		
V _{ref}	Reference output voltage	V _O
Timing Section		
t _{d(TXD-BUSon)}	Delay TXD to bus active	Driver t _{PLH}
t _{d(TXD-BUSoff)}	Delay TXD to bus inactive	Driver t _{PHL}
t _{d(BUSon-RXD)}	Delay bus active to RXD	Receiver t _{PHL}
t _{d(BUSoff-RXD)}	Delay bus inactive to RXD	Receiver t _{PLH}
	t _{d(TXD-BUSon)} + t _{d(BUSon-RXD)}	Device t _{LOOP1}
	t _{d(TXD-BUSoff)} + t _{d(BUSoff-RXD)}	Device t _{LOOP2}
t _{dom(TXD)}	Dominant time-out	Driver t _(dom)
S-Pin Section		
V _{IH}	High-level input voltage	Recommended V _{IH}
V _{IL}	Low-level input voltage	Recommended V _{IL}
I _{IH}	High-level input current	I _{IH}
I _{IL}	Low-level input current	I _{IL}

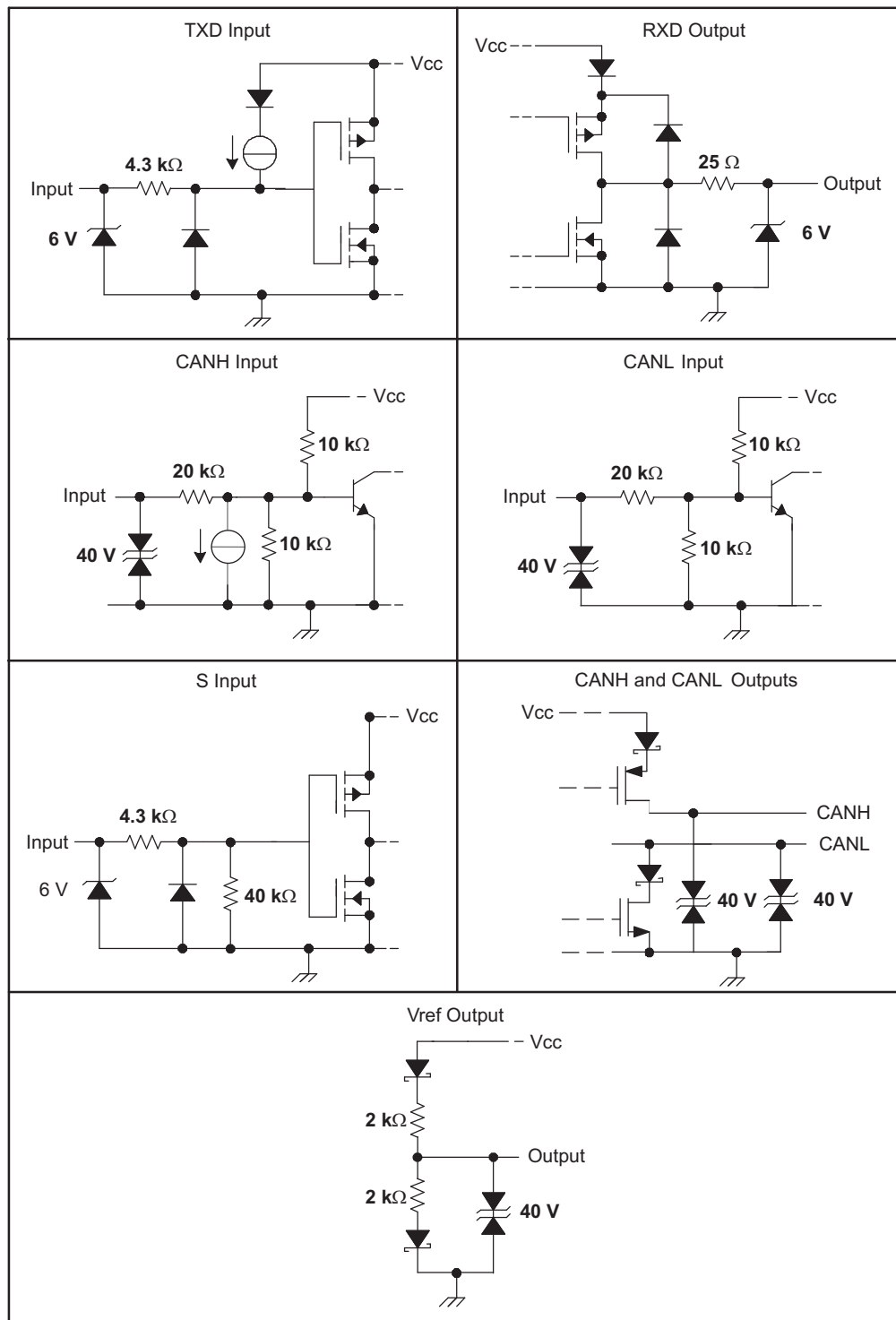
(1) From TJA1050 Product Specification, Philips Semiconductors, 2002 May 16

Equivalent Input and Output Schematic Diagrams

TYPICAL CHARACTERISTICS

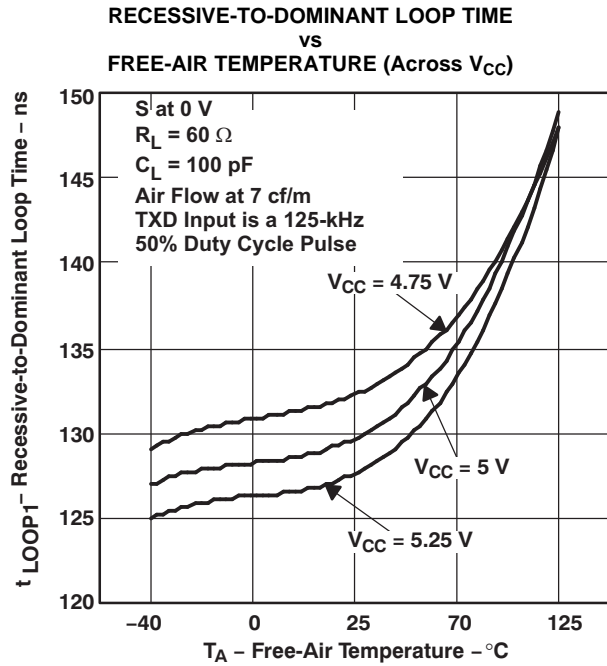

Figure 12.

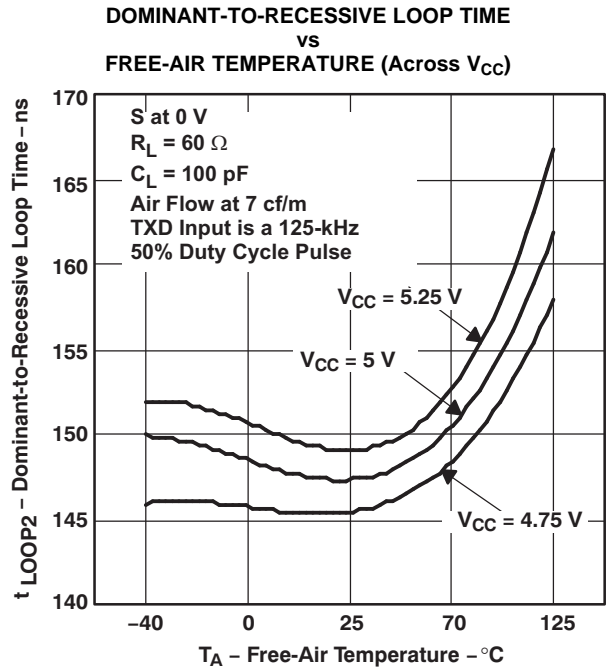

Figure 13.

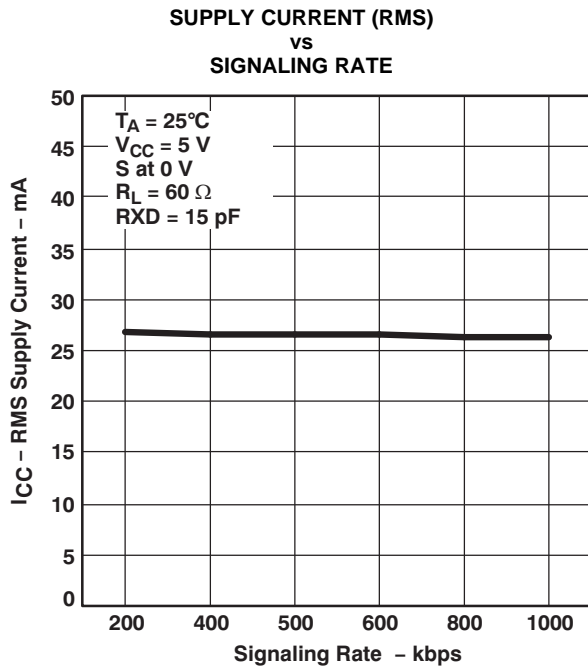

Figure 14.

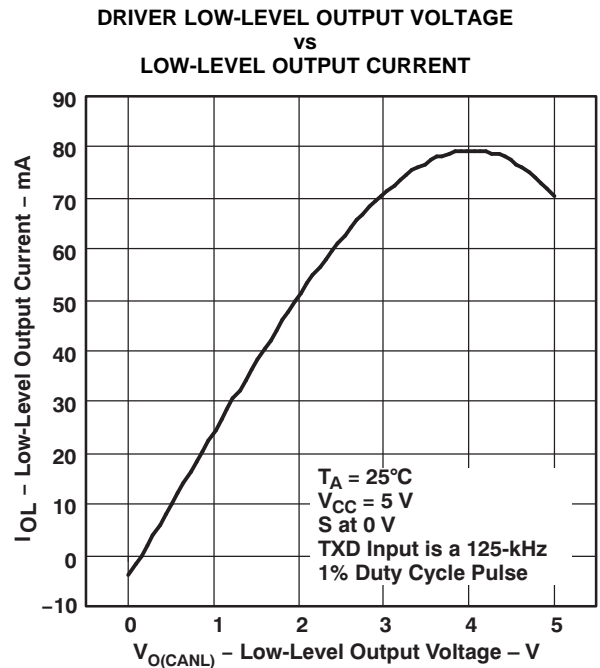

Figure 15.

TYPICAL CHARACTERISTICS (continued)

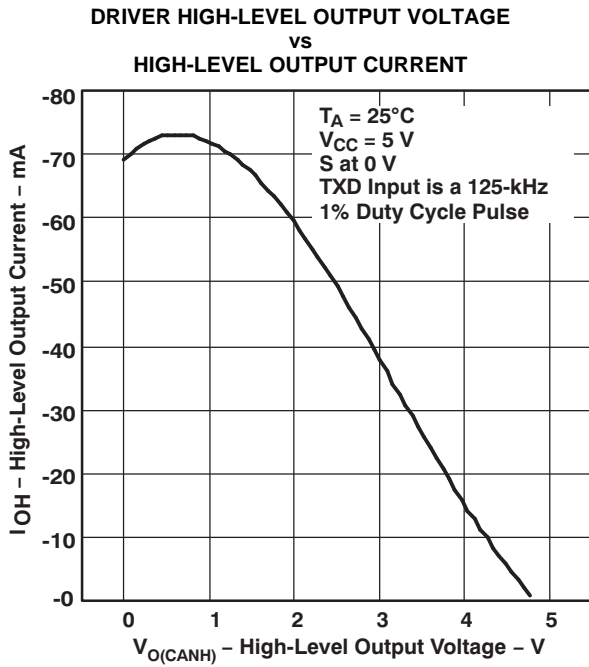

Figure 16.

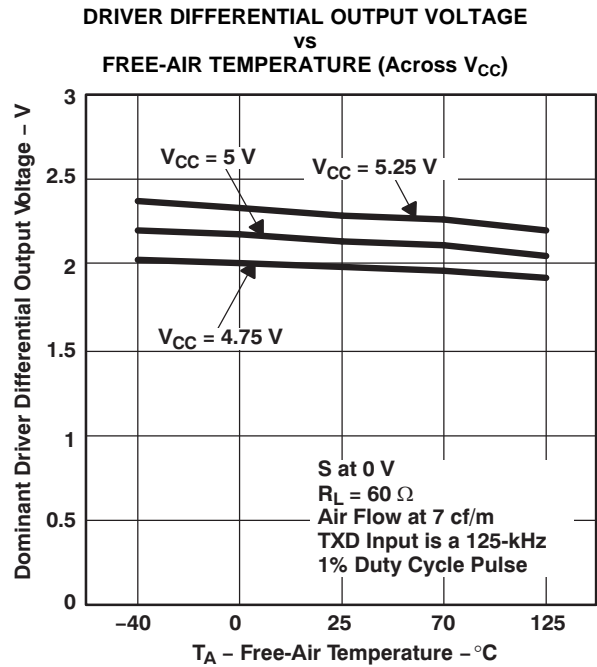

Figure 17.

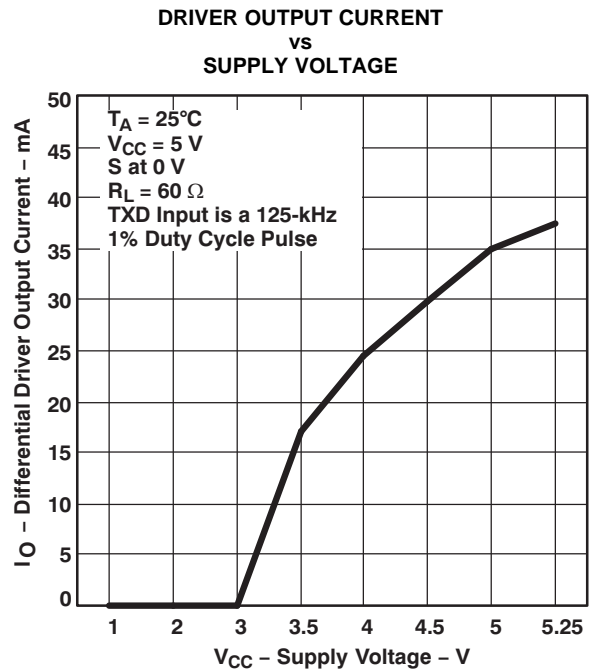

Figure 18.

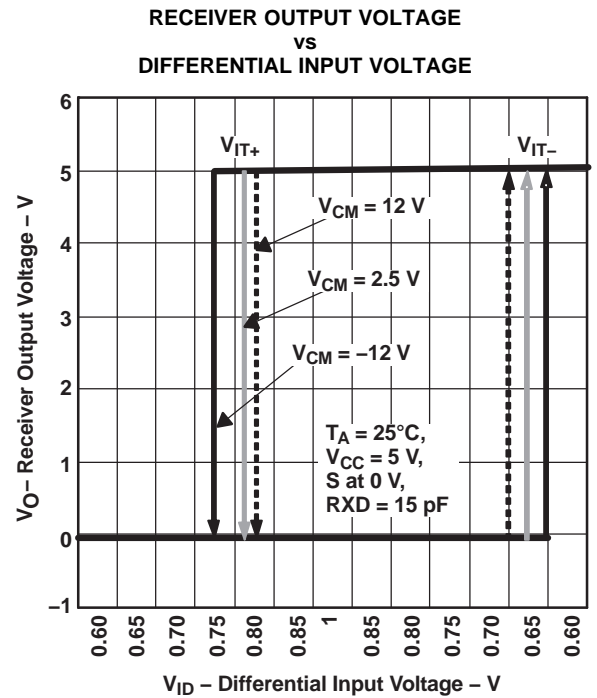

Figure 19.

TYPICAL CHARACTERISTICS (continued)

TYPICAL ELECTROMAGNETIC EMISSIONS UP TO 50 MHz (Peak Amplitude)

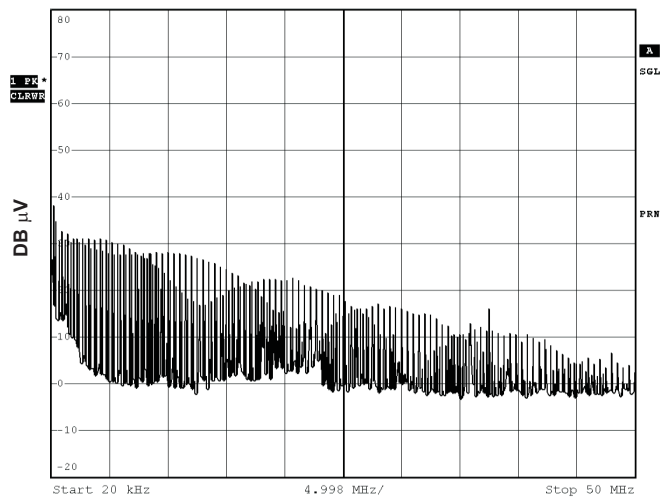

Figure 20.

TYPICAL ELECTROMAGNETIC IMMUNITY PERFORMANCE

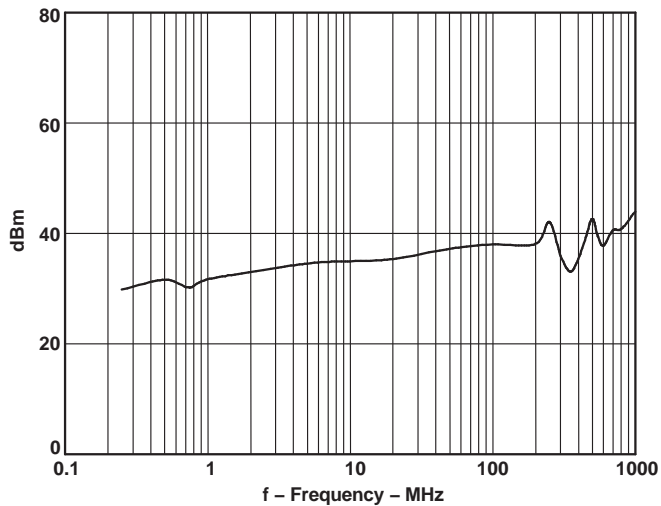

Figure 21.

PACKAGING INFORMATION

Orderable Device	Status (1)	Package Type	Package Drawing	Pins	Package Qty	Eco Plan (2)	Lead finish/ Ball material (6)	MSL Peak Temp (3)	Op Temp (°C)	Device Marking (4/5)	Samples
SN65HVD1050MDREP	ACTIVE	SOIC	D	8	2500	RoHS & Green	NIPDAU	Level-1-260C-UNLIM	-55 to 125	1050EP	Samples
V62/07608-01XE	ACTIVE	SOIC	D	8	2500	RoHS & Green	NIPDAU	Level-1-260C-UNLIM	-55 to 125	1050EP	Samples

(1) The marketing status values are defined as follows:

ACTIVE: Product device recommended for new designs.

LIFEBUY: TI has announced that the device will be discontinued, and a lifetime-buy period is in effect.

NRND: Not recommended for new designs. Device is in production to support existing customers, but TI does not recommend using this part in a new design.

PREVIEW: Device has been announced but is not in production. Samples may or may not be available.

OBSOLETE: TI has discontinued the production of the device.

(2) **RoHS:** TI defines "RoHS" to mean semiconductor products that are compliant with the current EU RoHS requirements for all 10 RoHS substances, including the requirement that RoHS substance do not exceed 0.1% by weight in homogeneous materials. Where designed to be soldered at high temperatures, "RoHS" products are suitable for use in specified lead-free processes. TI may reference these types of products as "Pb-Free".

RoHS Exempt: TI defines "RoHS Exempt" to mean products that contain lead but are compliant with EU RoHS pursuant to a specific EU RoHS exemption.

Green: TI defines "Green" to mean the content of Chlorine (Cl) and Bromine (Br) based flame retardants meet JS709B low halogen requirements of <=1000ppm threshold. Antimony trioxide based flame retardants must also meet the <=1000ppm threshold requirement.

(3) MSL, Peak Temp. - The Moisture Sensitivity Level rating according to the JEDEC industry standard classifications, and peak solder temperature.

(4) There may be additional marking, which relates to the logo, the lot trace code information, or the environmental category on the device.

(5) Multiple Device Markings will be inside parentheses. Only one Device Marking contained in parentheses and separated by a "~" will appear on a device. If a line is indented then it is a continuation of the previous line and the two combined represent the entire Device Marking for that device.

(6) Lead finish/Ball material - Orderable Devices may have multiple material finish options. Finish options are separated by a vertical ruled line. Lead finish/Ball material values may wrap to two lines if the finish value exceeds the maximum column width.

Important Information and Disclaimer:The information provided on this page represents TI's knowledge and belief as of the date that it is provided. TI bases its knowledge and belief on information provided by third parties, and makes no representation or warranty as to the accuracy of such information. Efforts are underway to better integrate information from third parties. TI has taken and continues to take reasonable steps to provide representative and accurate information but may not have conducted destructive testing or chemical analysis on incoming materials and chemicals. TI and TI suppliers consider certain information to be proprietary, and thus CAS numbers and other limited information may not be available for release.

In no event shall TI's liability arising out of such information exceed the total purchase price of the TI part(s) at issue in this document sold by TI to Customer on an annual basis.

OTHER QUALIFIED VERSIONS OF SN65HVD1050-EP :

- Catalog : [SN65HVD1050](#)
- Automotive : [SN65HVD1050-Q1](#)

NOTE: Qualified Version Definitions:

- Catalog - TI's standard catalog product
- Automotive - Q100 devices qualified for high-reliability automotive applications targeting zero defects

TAPE AND REEL INFORMATION

QUADRANT ASSIGNMENTS FOR PIN 1 ORIENTATION IN TAPE

*All dimensions are nominal

Device	Package Type	Package Drawing	Pins	SPQ	Reel Diameter (mm)	Reel Width W1 (mm)	A0 (mm)	B0 (mm)	K0 (mm)	P1 (mm)	W (mm)	Pin1 Quadrant
SN65HVD1050MDREP	SOIC	D	8	2500	330.0	12.4	6.4	5.2	2.1	8.0	12.0	Q1

TAPE AND REEL BOX DIMENSIONS

*All dimensions are nominal

Device	Package Type	Package Drawing	Pins	SPQ	Length (mm)	Width (mm)	Height (mm)
SN65HVD1050MDREP	SOIC	D	8	2500	350.0	350.0	43.0



D0008A

PACKAGE OUTLINE

SOIC - 1.75 mm max height

SMALL OUTLINE INTEGRATED CIRCUIT



4214825/C 02/2019

NOTES:

1. Linear dimensions are in inches [millimeters]. Dimensions in parenthesis are for reference only. Controlling dimensions are in inches. Dimensioning and tolerancing per ASME Y14.5M.
2. This drawing is subject to change without notice.
3. This dimension does not include mold flash, protrusions, or gate burrs. Mold flash, protrusions, or gate burrs shall not exceed $.006$ [0.15] per side.
4. This dimension does not include interlead flash.
5. Reference JEDEC registration MS-012, variation AA.

EXAMPLE BOARD LAYOUT

D0008A

SOIC - 1.75 mm max height

SMALL OUTLINE INTEGRATED CIRCUIT



LAND PATTERN EXAMPLE
 EXPOSED METAL SHOWN
 SCALE:8X



SOLDER MASK DETAILS

4214825/C 02/2019

NOTES: (continued)

- 6. Publication IPC-7351 may have alternate designs.
- 7. Solder mask tolerances between and around signal pads can vary based on board fabrication site.

EXAMPLE STENCIL DESIGN

D0008A

SOIC - 1.75 mm max height

SMALL OUTLINE INTEGRATED CIRCUIT



SOLDER PASTE EXAMPLE
BASED ON .005 INCH [0.125 MM] THICK STENCIL
SCALE:8X

4214825/C 02/2019

NOTES: (continued)

8. Laser cutting apertures with trapezoidal walls and rounded corners may offer better paste release. IPC-7525 may have alternate design recommendations.
9. Board assembly site may have different recommendations for stencil design.

IMPORTANT NOTICE AND DISCLAIMER

TI PROVIDES TECHNICAL AND RELIABILITY DATA (INCLUDING DATA SHEETS), DESIGN RESOURCES (INCLUDING REFERENCE DESIGNS), APPLICATION OR OTHER DESIGN ADVICE, WEB TOOLS, SAFETY INFORMATION, AND OTHER RESOURCES "AS IS" AND WITH ALL FAULTS, AND DISCLAIMS ALL WARRANTIES, EXPRESS AND IMPLIED, INCLUDING WITHOUT LIMITATION ANY IMPLIED WARRANTIES OF MERCHANTABILITY, FITNESS FOR A PARTICULAR PURPOSE OR NON-INFRINGEMENT OF THIRD PARTY INTELLECTUAL PROPERTY RIGHTS.

These resources are intended for skilled developers designing with TI products. You are solely responsible for (1) selecting the appropriate TI products for your application, (2) designing, validating and testing your application, and (3) ensuring your application meets applicable standards, and any other safety, security, regulatory or other requirements.

These resources are subject to change without notice. TI grants you permission to use these resources only for development of an application that uses the TI products described in the resource. Other reproduction and display of these resources is prohibited. No license is granted to any other TI intellectual property right or to any third party intellectual property right. TI disclaims responsibility for, and you will fully indemnify TI and its representatives against, any claims, damages, costs, losses, and liabilities arising out of your use of these resources.

TI's products are provided subject to [TI's Terms of Sale](#) or other applicable terms available either on [ti.com](https://www.ti.com) or provided in conjunction with such TI products. TI's provision of these resources does not expand or otherwise alter TI's applicable warranties or warranty disclaimers for TI products.

TI objects to and rejects any additional or different terms you may have proposed.

Mailing Address: Texas Instruments, Post Office Box 655303, Dallas, Texas 75265
Copyright © 2023, Texas Instruments Incorporated

Looking for pricing, stock, or lifecycle information?

Click below to explore more details on WIN SOURCE:

- ⊖ [View SMBJ5358AE3/TR13 on WIN SOURCE](#)
- ⊖ [Microchip Technology](#) Information

Optimize Your Supply Chain with WIN SOURCE Solutions

- ✓ Global Sourcing Solution
- ✓ Obsolete Management
- ✓ Cost Control Management
- ✓ Shortage Management
- ✓ Alternative Solution
- ✓ Excess Inventory Management