



# THE DATASHEET OF CSPEMI400G



# CSPEMI400G

## SIM Card EMI Filter Array with ESD Protection

### Product Description

The CSPEMI400G is an EMI filter array with ESD protection, which integrates three pi filters (C–R–C) and two additional channels of ESD protection. The CSPEMI400G has component values of 20 pF – 47 Ω – 20 pF, and 20 pF – 100 Ω – 20 pF. The parts include avalanche-type ESD diodes on every pin, which provide a very high level of protection for sensitive electronic components that may be subjected to electrostatic discharge (ESD). The ESD diodes connected to the filter ports safely dissipate ESD strikes of ±10 kV, exceeding the maximum requirement of the IEC 61000–4–2 international standard. Using the MIL–STD–883 (Method 3015) specification for Human Body Model (HBM) ESD, the pins are protected for contact discharges at greater than ±25 kV.

The ESD diodes on pins A4 and C4 ports are designed and characterized to safely dissipate ESD strikes of ±10 kV, well beyond the maximum requirement of the IEC 61000–4–2 international standard.

This device is particularly well suited for portable electronics (e.g. mobile handsets, PDAs, notebook computers) because of its small package format and easy-to-use pin assignments. In particular, the CSPEMI400G is ideal for EMI filtering and protecting data lines from ESD for the SIM card slot in mobile handsets.

The CSPEMI400G is available in a space-saving, low-profile Chip Scale Package with lead-free finishing.

### Features

- Three Channels of EMI Filtering, each with ESD Protection
- Two Additional Channels of ESD-Only Protection
- ±10 kV ESD Protection (IEC 61000–4–2, Contact Discharge)
- ±25 kV ESD Protection (HBM)
- Greater than 30 dB of Attenuation at 1 GHz
- 10-Bump, 1.960 mm x 1.330 mm Footprint Chip Scale Package (CSP)
- These Devices are Pb-Free and are RoHS Compliant

### Applications

- SIM Card Slot in Mobile Handsets
- I/O Port Protection for Mobile Handsets, Notebook Computers, PDAs, etc.
- EMI Filtering for Data Ports in Cell Phones, PDAs or Notebook Computers



ON Semiconductor®

<http://onsemi.com>



WLCSP10  
CASE 567BL

### MARKING DIAGRAM

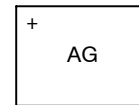

AG = CSPEMI400G

### ORDERING INFORMATION

Device	Package	Shipping†
CSPEMI400G	CSP-10 (Pb-Free)	3500/Tape & Reel

†For information on tape and reel specifications, including part orientation and tape sizes, please refer to our Tape and Reel Packaging Specification Brochure, BRD8011/D.

# CSPEMI400G

## ELECTRICAL SCHEMATIC

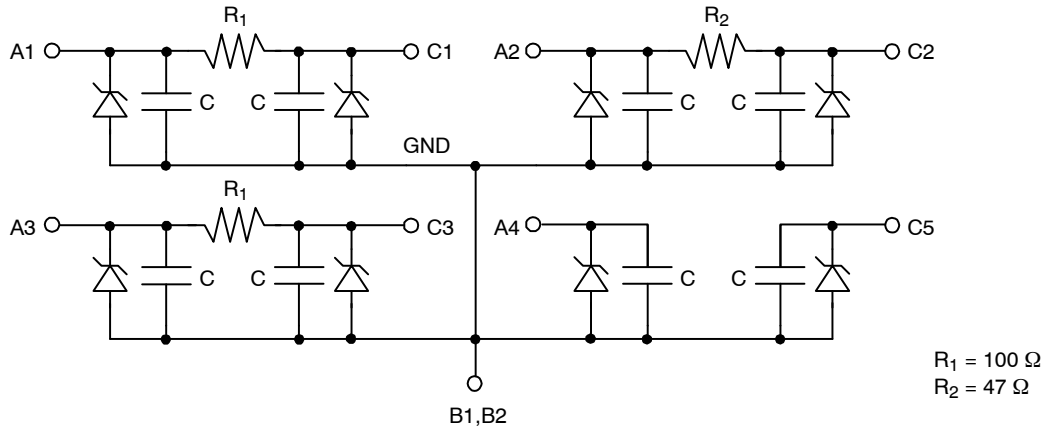

**Table 1. PIN DESCRIPTIONS**

Type	Pin	Description
EMI Filter	A1	EMI Filter with ESD Protection for RST Signal
	C1	EMI Filter with ESD Protection for RST Signal
EMI Filter	A2	EMI Filter with ESD Protection for CLK Signal
	C2	EMI Filter with ESD Protection for CLK Signal
Device Ground	B1	Device Ground
	B2	Device Ground
EMI Filter	A3	DAT EMI Filter with ESD Protection
	C3	DAT EMI Filter with ESD Protection
ESD Channel	A4	ESD Protection Channel – V <sub>CC</sub> Supply
ESD Channel	C4	ESD Protection Channel

## PACKAGE / PINOUT DIAGRAMS

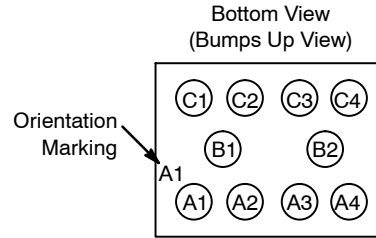
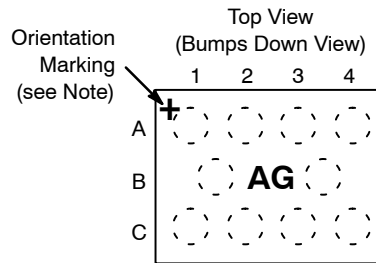

CSPEMI400G  
CSP Package

Note: Lead-free devices are specified by using a "+" character for the top side orientation mark.

## SPECIFICATIONS

**Table 2. ABSOLUTE MAXIMUM RATINGS**

Parameter	Rating	Units
Storage Temperature Range	-65 to +150	°C
DC Power per Resistor	100	mW
DC Package Power Rating	300	mW

Stresses exceeding Maximum Ratings may damage the device. Maximum Ratings are stress ratings only. Functional operation above the Recommended Operating Conditions is not implied. Extended exposure to stresses above the Recommended Operating Conditions may affect device reliability.

**Table 3. STANDARD OPERATING CONDITIONS**

Parameter	Rating	Units
Operating Temperature Range	-40 to +85	°C

# CSPEMI400G

**Table 4. ELECTRICAL OPERATING CHARACTERISTICS** (Note 1)

Symbol	Parameter	Conditions	Min	Typ	Max	Units
R <sub>1</sub>	Resistance of R <sub>1</sub>		80	100	120	Ω
R <sub>2</sub>	Resistance of R <sub>2</sub>		38	47	56	Ω
C	Capacitance	V <sub>IN</sub> = 2.5 VDC, 1 MHz, 30 mV ac	16	20	24	pF
V <sub>STANDOFF</sub>	Stand-off Voltage	I = 10 μA		6.0		V
I <sub>LEAK</sub>	Diode Leakage Current	V <sub>BIAS</sub> = 3.3 V			300	nA
V <sub>SIG</sub>	Signal Voltage Positive Clamp Negative Clamp	I <sub>LOAD</sub> = 10 mA I <sub>LOAD</sub> = -10 mA	5.6 -1.5	6.8 -0.8	9.0 -0.4	V
V <sub>ESD</sub>	In-system ESD Withstand Voltage a) Human Body Model, MIL-STD-883, Method 3015 b) Contact Discharge per IEC 61000-4-2	(Notes 2 and 4)	±25 ±10			kV
V <sub>CL</sub>	Clamping Voltage during ESD Discharge MIL-STD-883 (Method 3015), 8 kV Positive Transients Negative Transients	(Notes 2, 3 and 4)			+12 -7	V
f <sub>C1</sub>	Cut-off frequency Z <sub>SOURCE</sub> = 50 Ω, Z <sub>LOAD</sub> = 50 Ω	R = 100 Ω, C = 20 pF		77		MHz
f <sub>C2</sub>	Cut-off frequency Z <sub>SOURCE</sub> = 50 Ω, Z <sub>LOAD</sub> = 50 Ω	R = 47 Ω, C = 20 pF		85		MHz

1. T<sub>A</sub> = 25°C unless otherwise specified.
2. ESD applied to input and output pins with respect to GND, one at a time.
3. Clamping voltage is measured at the opposite side of the EMI filter to the ESD pin. For example, if ESD is applied to Pin A1, then clamping voltage is measured at Pin C1.
4. Unused pins are left open.

# CSPEMI400G

## PERFORMANCE INFORMATION

Typical Filter Performance (nominal conditions unless specified otherwise, 50 Ω Environment)

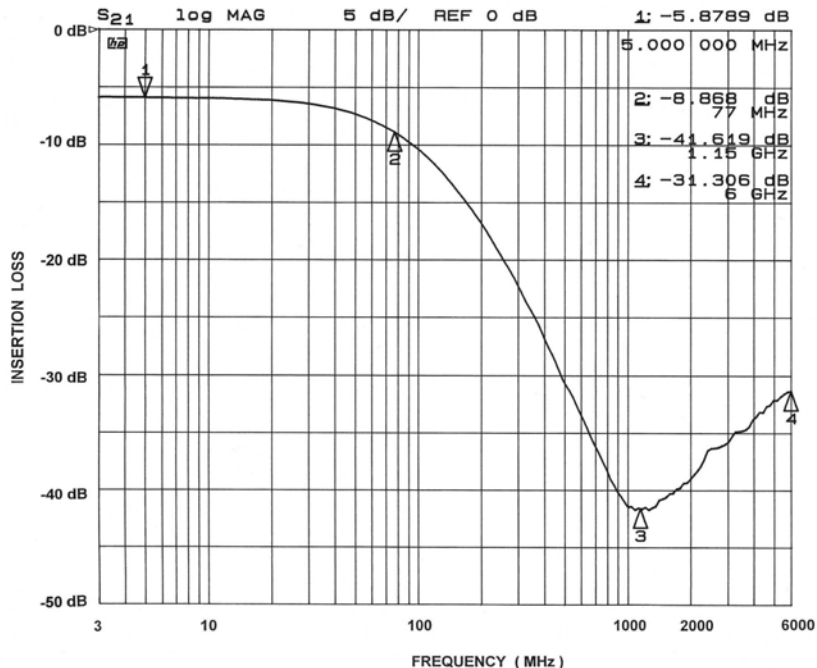

Figure 1. A1-C1 EMI Filter Performance



Figure 2. A2-C2 EMI Filter Performance

# CSPEMI400G

## PERFORMANCE INFORMATION (Cont'd)

Typical Filter Performance (nominal conditions unless specified otherwise, 50 Ω Environment)

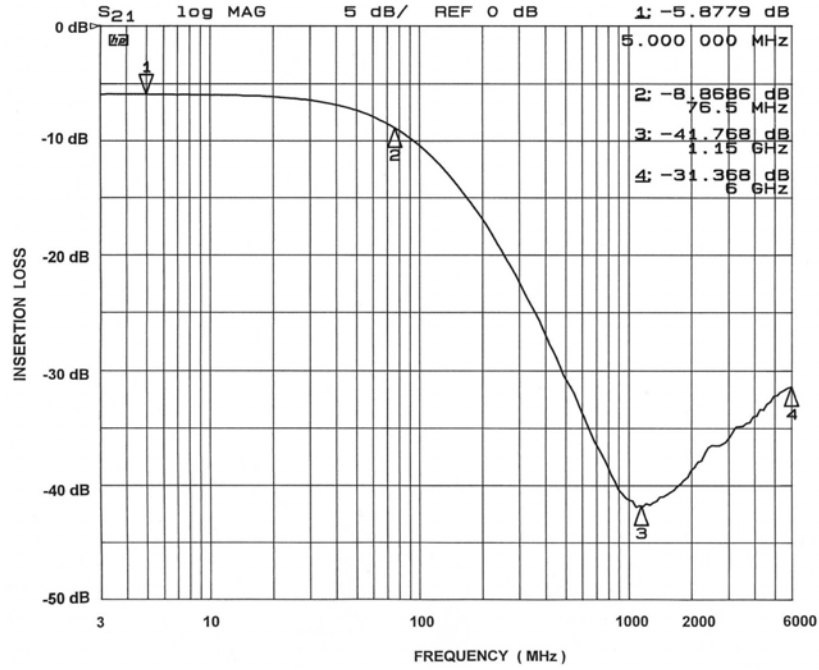

Figure 3. A3-C3 EMI Filter Performance

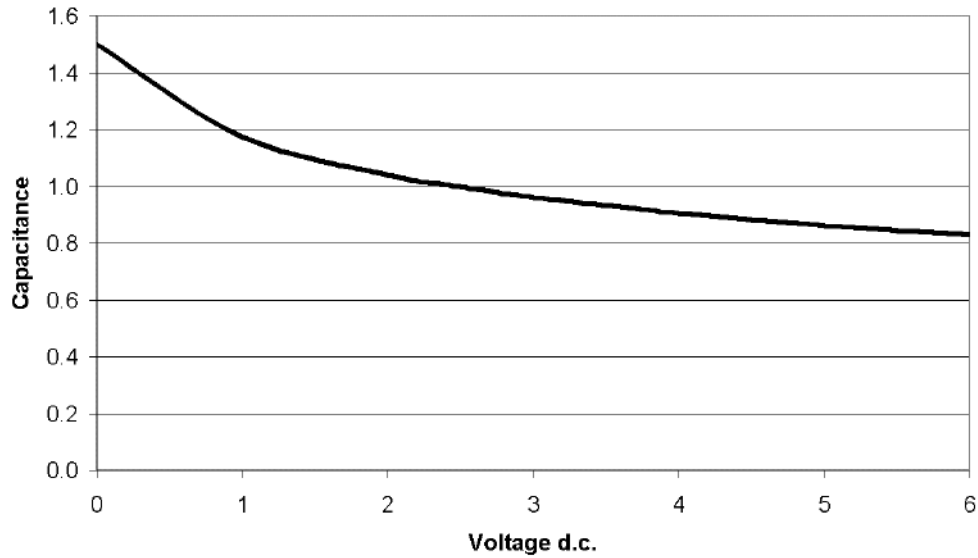
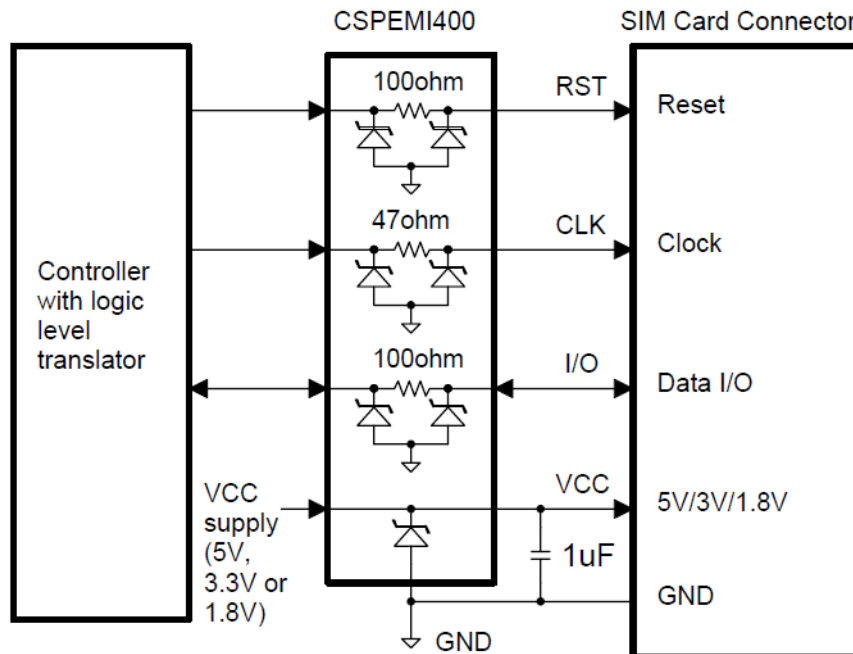

Figure 4. Typical Diode Capacitance vs. Input Voltage (normalized to 2.5 VDC)

# CSPEMI400G

## APPLICATION INFORMATION

The CSPEMI400G provides a bidirectional filter and protector for all the signals and the power line on the SIM (subscriber identity module) card connector. SIM cards are found in all GSM cellular phones and in some other handheld devices or card readers. The ESD diodes protect the controller against possible ESD strikes that may occur when the connector pins are exposed during direct contact, or during insertion of the SIM card into the card slot. The EMI filter suppresses all high-frequency noise, preventing the unwanted EMI signals from both entering and exiting the main board. The signals that interface with the SIM card are the Reset, the Clock and the bidirectional data I/O, as shown in Figure 5.



Note: One channel of the CSPEMI400G with a zener diode is not shown on the diagram.

**Figure 5. Typical Application Diagram for the SIM Card Interface**

For best filter and ESD performance, both GND bumps (B1, B2) of the CSPEMI400G should be directly connected to the Ground plane. A small capacitor of about 1  $\mu$ F is required next to the V<sub>CC</sub> pin of the SIM connector in order to improve stability of the SIM card supply rail.

# CSPEMI400G

## APPLICATION INFORMATION

Parameter	Value
Pad Size on PCB	0.240 mm
Pad Shape	Round
Pad Definition	Non-Solder Mask defined pads
Solder Mask Opening	0.290 mm Round
Solder Stencil Thickness	0.125 mm – 0.150 mm
Solder Stencil Aperture Opening (laser cut, 5% tapered walls)	0.300 mm Round
Solder Flux Ratio	50/50 by volume
Solder Paste Type	No Clean
Pad Protective Finish	OSP (Entek Cu Plus 106A)
Tolerance – Edge To Corner Ball	±50 µm
Solder Ball Side Coplanarity	±20 µm
Maximum Dwell Time Above Liquidous	60 seconds
Maximum Soldering Temperature for Lead-free Devices using a Lead-free Solder Paste	260°C

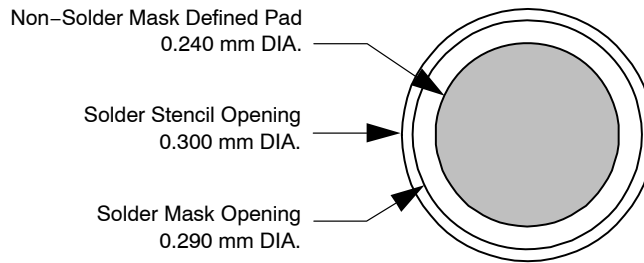

Figure 6. Recommended Non-Solder Mask Defined Pad Illustration

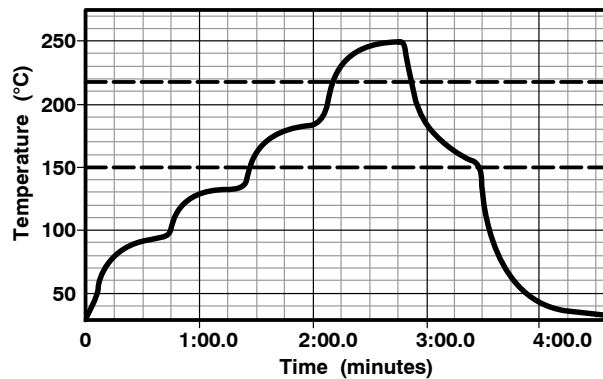
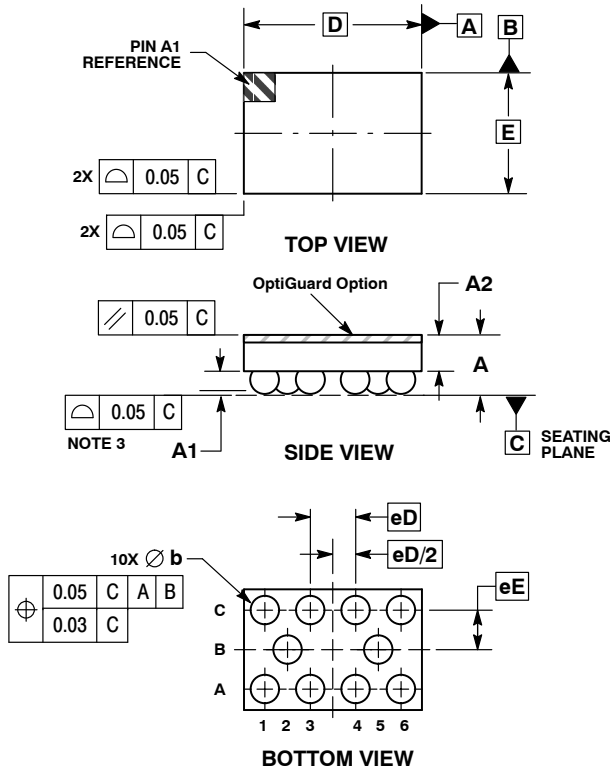

Figure 7. Lead-free (SnAgCu) Solder Ball Reflow Profile

# CSPEMI400G

## PACKAGE DIMENSIONS

WLCSP10, 1.96x1.33  
CASE 567BL  
ISSUE O



**NOTES:**

1. DIMENSIONING AND TOLERANCING PER ASME Y14.5M, 1994.
2. CONTROLLING DIMENSION: MILLIMETERS.
3. COPLANARITY APPLIES TO SPHERICAL CROWNS OF SOLDER BALLS.

MILLIMETERS		
DIM	MIN	MAX
A	0.56	0.72
A1	0.21	0.27
A2	0.40 REF	
b	0.29	0.35
D	1.96 BSC	
E	1.33 BSC	
eD	0.50 BSC	
eE	0.435 BSC	

**RECOMMENDED SOLDERING FOOTPRINT\***

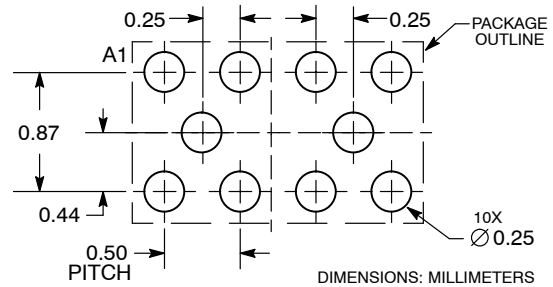

\*For additional information on our Pb-Free strategy and soldering details, please download the ON Semiconductor Soldering and Mounting Techniques Reference Manual, SOLDERRM/D.

ON Semiconductor and are registered trademarks of Semiconductor Components Industries, LLC (SCILLC). SCILLC reserves the right to make changes without further notice to any products herein. SCILLC makes no warranty, representation or guarantee regarding the suitability of its products for any particular purpose, nor does SCILLC assume any liability arising out of the application or use of any product or circuit, and specifically disclaims any and all liability, including without limitation special, consequential or incidental damages. "Typical" parameters which may be provided in SCILLC data sheets and/or specifications can and do vary in different applications and actual performance may vary over time. All operating parameters, including "Typicals" must be validated for each customer application by customer's technical experts. SCILLC does not convey any license under its patent rights nor the rights of others. SCILLC products are not designed, intended, or authorized for use as components in systems intended for surgical implant into the body, or other applications intended to support or sustain life, or for any other application in which the failure of the SCILLC product could create a situation where personal injury or death may occur. Should Buyer purchase or use SCILLC products for any such unintended or unauthorized application, Buyer shall indemnify and hold SCILLC and its officers, employees, subsidiaries, affiliates, and distributors harmless against all claims, costs, damages, and expenses, and reasonable attorney fees arising out of, directly or indirectly, any claim of personal injury or death associated with such unintended or unauthorized use, even if such claim alleges that SCILLC was negligent regarding the design or manufacture of the part. SCILLC is an Equal Opportunity/Affirmative Action Employer. This literature is subject to all applicable copyright laws and is not for resale in any manner.

**PUBLICATION ORDERING INFORMATION**

**LITERATURE FULFILLMENT:**  
Literature Distribution Center for ON Semiconductor  
P.O. Box 5163, Denver, Colorado 80217 USA  
**Phone:** 303-675-2175 or 800-344-3860 Toll Free USA/Canada  
**Fax:** 303-675-2176 or 800-344-3867 Toll Free USA/Canada  
**Email:** orderlit@onsemi.com

**N. American Technical Support:** 800-282-9855 Toll Free USA/Canada  
**Europe, Middle East and Africa Technical Support:**  
Phone: 421 33 790 2910  
**Japan Customer Focus Center**  
Phone: 81-3-5817-1050

**ON Semiconductor Website:** [www.onsemi.com](http://www.onsemi.com)  
**Order Literature:** <http://www.onsemi.com/orderlit>  
For additional information, please contact your local Sales Representative

## Looking for pricing, stock, or lifecycle information?

Click below to explore more details on WIN SOURCE:

 [View CSPEMI400G](#) on WIN SOURCE

 [ON Semiconductor](#) Information

## Optimize Your Supply Chain with WIN SOURCE Solutions

-  Global Sourcing Solution
-  Obsolete Management
-  Cost Control Management
-  Shortage Management
-  Alternative Solution
-  Excess Inventory Management