

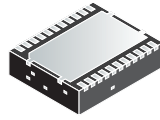

**THE DATASHEET OF
CSD97370AQ5M**





Synchronous Buck NexFET™ Power Stage

Check for Samples: [CSD97370AQ5M](#)

FEATURES

- 90% System Efficiency at 25A
- Input Voltages up to 22V
- High Frequency Operation (Up To 2MHz)
- Incorporates Power Block Technology
- High Density – SON 5-mm × 6-mm Footprint
- Low Power Loss 2.8W at 25A
- Ultra Low Inductance Package
- System Optimized PCB Footprint
- Universal 5V PWM Signal Compatibility
- 3-State PWM Input
- Integrated Bootstrap Diode
- Pre-Bias Start-Up Protection
- Shoot Through Protection
- RoHS Compliant – Lead Free Terminal Plating
Halogen Free

APPLICATIONS

- Synchronous Buck Converters
- Multiphase Synchronous Buck Converters
- POL DC-DC Converters
- Memory and Graphic Cards
- Desktop and Server VR11.x and VR12.x V-Core Synchronous Buck Converters

ORDERING INFORMATION

Device	Package	Media	Qty	Ship
CSD97370AQ5M	SON 5-mm × 6-mm Plastic Package	13-Inch Reel	2500	Tape and Reel

DESCRIPTION

The CSD97370AQ5M NexFET Power Stage is an optimized design for use in a high power, high density Synchronous Buck converter. This product integrates an enhanced gate driver IC and Power Block Technology to complete the power stage switching function. This combination produces a high current, high efficiency, high speed switching device and delivers an excellent thermal solution in a small 5-mm × 6-mm outline package due to its large ground based thermal pad. In addition, the PCB footprint has been optimized to help reduce design time and simplify the completion of the overall system design.

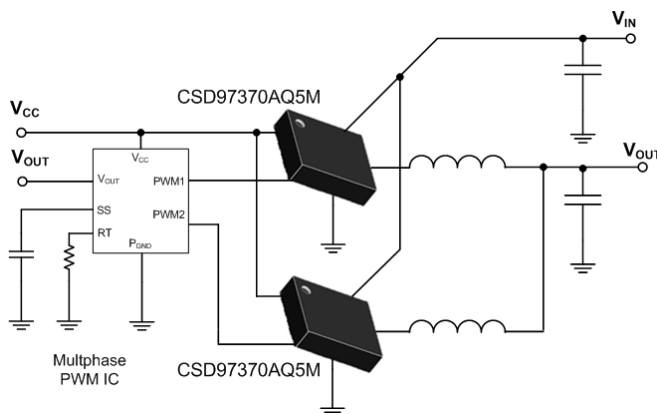
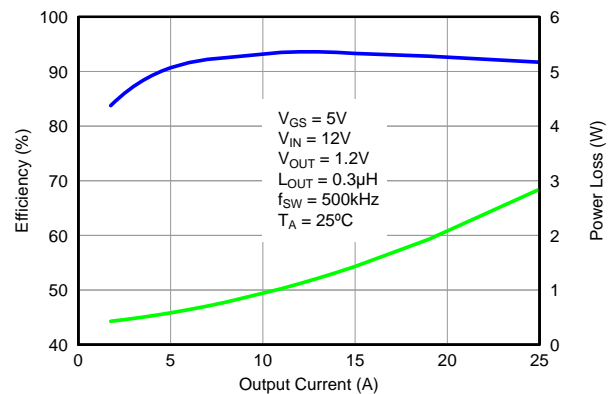
Figure 1. Application Diagram

Figure 2. Efficiency and Power Loss

Please be aware that an important notice concerning availability, standard warranty, and use in critical applications of Texas Instruments semiconductor products and disclaimers thereto appears at the end of this data sheet.

CSD97370AQ5M

SLPS352A – SEPTEMBER 2011 – REVISED MAY 2012

www.ti.com



These devices have limited built-in ESD protection. The leads should be shorted together or the device placed in conductive foam during storage or handling to prevent electrostatic damage to the MOS gates.

ABSOLUTE MAXIMUM RATINGS⁽¹⁾

T_A = 25°C (unless otherwise noted)

	VALUE		UNIT	
	MIN	MAX		
V _{IN} to P _{GND} ⁽²⁾		30	V	
V _{SW} to P _{GND} , V _{IN} to V _{SW}	-0.8	30	V	
V _{SW} to P _{GND} (10ns)	-7	32	V	
V _{DD} to P _{GND}	-0.3	6	V	
ENABLE to P _{GND} ⁽³⁾	-0.3	V _{DD} + 0.3	V	
PWM to P _{GND} ⁽³⁾	-0.3	V _{DD} + 0.3	V	
BOOT to BOOT_R ⁽³⁾	-0.3	V _{DD} + 0.3	V	
ESD Rating	Human Body Model (HBM)		2	kV
	Charged Device Model (CDM)		500	V
Power Dissipation, P _D		12	W	
Operating Temperature Range, T _J	-40	150	°C	
Storage Temperature Range, T _{STG}	-55	150	°C	

- (1) Stresses above those listed in "Absolute Maximum Ratings" may cause permanent damage to the device. These are stress ratings only and functional operation of the device at these or any other conditions beyond those indicated under "Recommended Operating Conditions" is not implied. Exposure to Absolute Maximum rated conditions for extended periods may affect device reliability.
- (2) V_{IN} to V_{SW} Max = 32V for 10ns
- (3) Should not exceed 6V

RECOMMENDED OPERATING CONDITIONS

T_A = 25° (unless otherwise noted)

Parameter	Conditions	MIN	MAX	UNIT
Gate Drive Voltage, V _{DD}		4.5	5.5	V
Input Supply Voltage, V _{IN}		3.3	22	V
Output Voltage, V _{OUT}			5.5	V
Continuous Output Current, I _{OUT}	V _{IN} = 12V, V _{DD} = 5V, V _{OUT} = 1.2V, f _{SW} = 500kHz, L _{OUT} = 0.3μH ⁽¹⁾		40	A
Peak Output Current, I _{OUT-PK} ⁽²⁾			60	A
Switching Frequency, f _{SW}	C _{BST} = 0.1μF (min)	200	2000	kHz
On Time Duty Cycle			85%	
Minimum PWM On Time		40		ns
Operating Temperature		-40	125	°C

- (1) Measurement made with six 10-μF (TDK C3216X5R1C106KT or equivalent) ceramic capacitors placed across V_{IN} to P_{GND} pins.
- (2) System conditions as defined in Note 1. Peak Output Current is applied for t_p = 50μs.

THERMAL INFORMATION

T_A = 25°C (unless otherwise noted)

PARAMETER		MIN	TYP	MAX	UNIT
R _{θJC}	Thermal Resistance, Junction-to-Case (Top of package)			20	°C/W
R _{θJB}	Thermal Resistance, Junction-to-Board ⁽¹⁾			2	°C/W

- (1) R_{θJB} value based on hottest board temperature within 1mm of the package.

ELECTRICAL CHARACTERISTICS

 $T_A = 25^\circ\text{C}$, $V_{DD} = \text{POR to } 5.5\text{V}$ (unless otherwise noted)

PARAMETER	CONDITIONS	MIN	TYP	MAX	UNIT
P_{Loss}					
Power Loss ⁽¹⁾	$V_{IN} = 12\text{V}$, $V_{DD} = 5\text{V}$, $V_{OUT} = 1.2\text{V}$, $I_{OUT} = 25\text{A}$, $f_{SW} = 500\text{kHz}$, $L_{OUT} = 0.3\mu\text{H}$, $T_J = 25^\circ\text{C}$	–	2.8	3.3	W
Power Loss ⁽²⁾	$V_{IN} = 12\text{V}$, $V_{DD} = 5\text{V}$, $V_{OUT} = 1.2\text{V}$, $I_{OUT} = 40\text{A}$, $f_{SW} = 500\text{kHz}$, $L_{OUT} = 0.3\mu\text{H}$, $T_J = 125^\circ\text{C}$	–	8	10	W
V_{IN}					
V_{IN} Quiescent Current (I_Q)	ENABLE = 0V, $V_{DD} = 5\text{V}$	–	–	100	μA
V_{DD}					
Standby Supply Current (I_{DD})	ENABLE = 0V, PWM = 0V	–	1	5	μA
Operating Supply Current (I_{DD})	ENABLE = 5V, PWM = 50% Duty cycle, $f_{SW} = 500\text{kHz}$	–	16	20	mA
POWER-ON RESET AND UNDER VOLTAGE LOCKOUT					
Power on Reset (V_{DD} Rising)		–	3.6	3.9	V
UVLO (V_{DD} Falling)		3.4	3.5	–	V
Hysteresis		100	–	250	mV
Startup Delay ⁽³⁾	ENABLE = PWM = 5V	–	600	1000	ns
ENABLE					
Logic Level Low Threshold (V_{IL})	Schmitt Trigger Input PWM = 5V (See Figure 5)	0.8	1	–	V
Logic Level High Threshold (V_{IH})		–	1.6	2.0	V
Threshold Hysteresis		–	580	–	mV
Weak Pull-down Impedance		–	100	–	k Ω
Rising Propagation Delay (t_{PDH})		–	600	–	ns
Falling Propagation Delay (t_{PDL})		–	200	–	ns
PWM					
I_{PVMH}	PWM = 5V	–	450	580	μA
I_{PVML}	PWM = 0V	–	–450	–580	μA
PWM Logic Level High (V_{PVMH})	$V_{DD} = \text{POR to } 5.5\text{V}$, $C_{PWM} = 10\text{pF}$ (See Figure 6)	–	–	4	V
PWM Logic Level Low (V_{PVML})		0.8	–	–	V
PWM 3-State open Voltage		–	2.4	–	V
PWM to VSW propagation delay (t_{PDLH} and t_{PDHL})		–	100	–	ns
3-State Shutdown Hold-off Time (t_{3HT})		–	100	–	ns
3-State Shutdown Propagation Delay (t_{3SD})		–	650	–	ns
3-State Recovery Propagation Delay (t_{3RD})		–	75	–	ns
BOOTSTRAP SWITCH					
Forward Voltage (V_{FBOOT})	$V_{DD} - V_{BOOT}$, $I_F = 20\text{mA}$	–	180	360	mV
Reverse Leakage (I_{RBOOT}) ⁽²⁾	$V_{BOOT} - V_{DD} = 20\text{V}$	–	0.15	1	μA

(1) Measurement made with six 10- μF (TDK C3216X5R1C106KT or equivalent) ceramic capacitors placed across V_{IN} to P_{GND} pins.

(2) Specified by design

(3) POR to V_{SW} rising

PIN CONFIGURATION

SON 5mm × 6mm
22-Pin Package
(Top View)

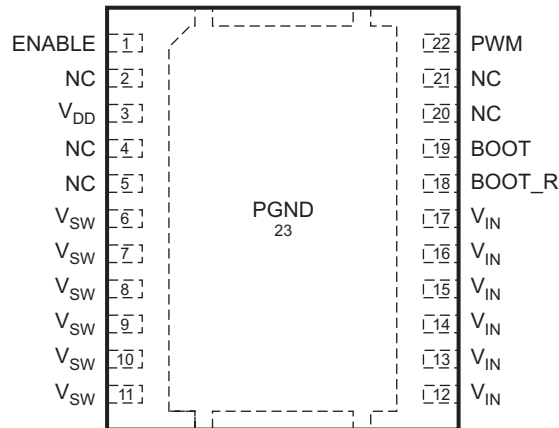

P0125-01

PIN DESCRIPTION

PIN		DESCRIPTION
NO.	NAME	
1	ENABLE	Enables device operation. If ENABLE=logic HIGH, turns on the device. If ENABLE=logic LOW, the device is turned off and MOSFET gates are actively pulled low. An internal 100kΩ pull down resistor will pull the ENABLE pin LOW if left floating.
2	NC	Not for electrical connection, connect to floating pad only.
3	V _{DD}	Supply Voltage to Gate Drivers and internal circuitry.
4	NC	Not for electrical connection, connect to floating pad only.
5	NC	Not for electrical connection, connect to floating pad only.
6	V _{SW}	Voltage Switching Node – pin connection to the output inductor.
7	V _{SW}	Voltage Switching Node – pin connection to the output inductor.
8	V _{SW}	Voltage Switching Node – pin connection to the output inductor.
9	V _{SW}	Voltage Switching Node – pin connection to the output inductor.
10	V _{SW}	Voltage Switching Node – pin connection to the output inductor.
11	V _{SW}	Voltage Switching Node – pin connection to the output inductor.
12	V _{IN}	Input Voltage Pin. Connect input capacitors close to this pin.
13	V _{IN}	Input Voltage Pin. Connect input capacitors close to this pin.
14	V _{IN}	Input Voltage Pin. Connect input capacitors close to this pin.
15	V _{IN}	Input Voltage Pin. Connect input capacitors close to this pin.
16	V _{IN}	Input Voltage Pin. Connect input capacitors close to this pin.
17	V _{IN}	Input Voltage Pin. Connect input capacitors close to this pin.
18	BOOT_R	Bootstrap capacitor connection. Connect a minimum 0.1μF 16V X5R, ceramic cap from BOOT to BOOT_R pins. The bootstrap capacitor provides the charge to turn on the Control FET. The bootstrap diode is integrated.
19	BOOT	
20	NC	Not for electrical connection, connect to floating pad only.
21	NC	Not for electrical connection, connect to floating pad only.
22	PWM	Pulse Width modulated 3-state input from external controller. Logic Low sets Control FET gate low and Sync FET gate high. Logic High sets Control FET gate high and Sync FET gate Low. Open or High Z sets both MOSFET gates low if greater than the 3-State Shutdown Hold-off Time (t _{3HT})
23	P _{GND}	Power Ground

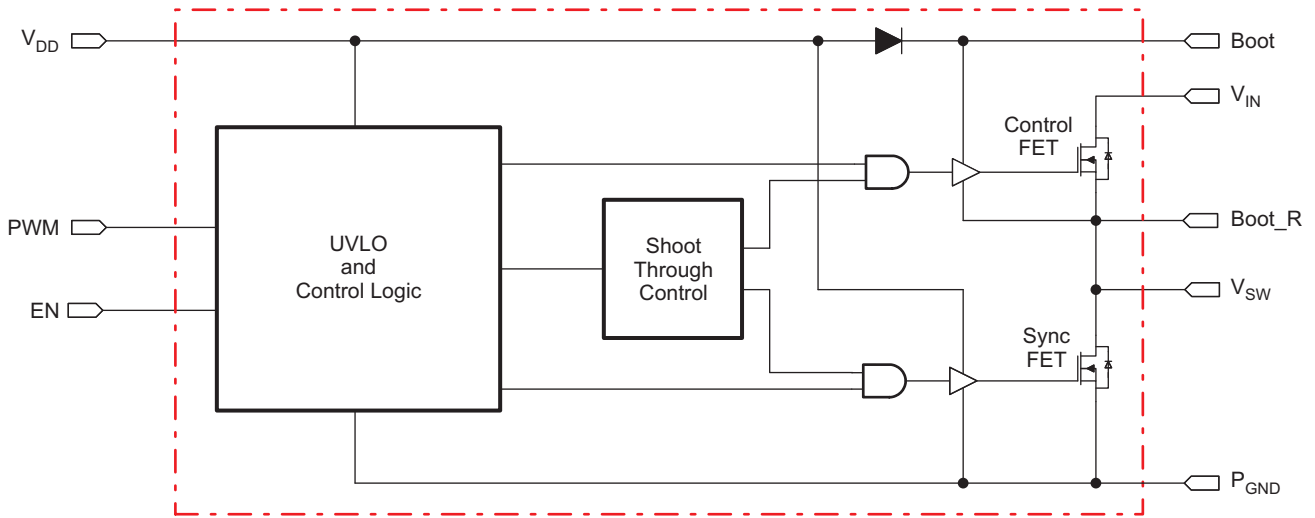

B0433-01

Figure 3. Functional Block Diagram

FUNCTIONAL DESCRIPTION

POWERING CSD97370AQ5M AND GATE DRIVERS

An external V_{DD} voltage is required to supply the integrated gate driver IC and provide the necessary gate drive power for the MOSFETS. The gate driver IC is capable of supplying in excess of 4 Amps peak current into the MOSFET gates to achieve fast switching. A 1 μ F 10V X5R or higher ceramic capacitor is recommended to bypass V_{DD} pin to PGND. A bootstrap circuit to provide gate drive power for the Control FET is also included. The bootstrap supply to drive the Control FET is generated by connecting a 100nF 16V X5R ceramic capacitor between BOOT and BOOT_R pins. An optional R_{BOOT} resistor which can be used to slow down the turn on speed of the Control FET and reduce voltage spikes on the Vsw node. A typical 1 Ω to 4.7 Ω value is a compromise between switching loss and V_{SW} spike amplitude.

UVLO (Under Voltage Lock Out)

The V_{DD} supply is monitored for UVLO conditions and both Control FET and Sync FET gates are held low until adequate supply is available. An internal comparator evaluates the V_{DD} voltage level and if V_{DD} is greater than the Power On Reset threshold (V_{POR}) the gate driver becomes active. If V_{DD} is less than the UVLO threshold, the gate driver is disabled and the internal MOSFET gates are actively driven low. At the rising edge of the V_{DD} voltage, both Control FET and Sync FET gates will be actively held low during V_{DD} transitions between 1.0V to V_{POR} . This region is referred to the Gate Drive Latch Zone (see Figure 4). In addition, at the falling edge of the V_{DD} voltage, both Control FET and Sync FET gates are actively held low during the UVLO to 1.0V transition.

The Power Stage CSD97370AQ5M device must be powered up and Enabled before the PWM signal is applied.

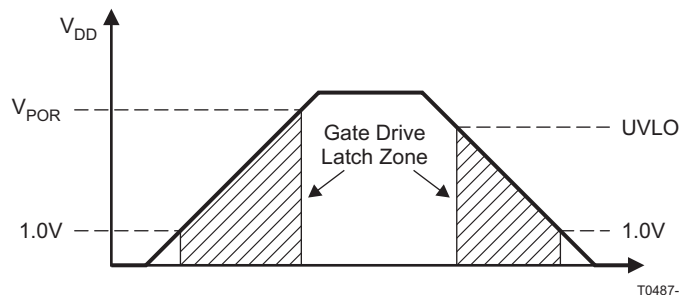

T0487-01

Figure 4. POR and UVLO

ENABLE

The ENABLE pin is TTL compatible. The logic level thresholds are sustained under all V_{DD} operating conditions between V_{POR} to V_{DD} . In addition, if this pin is left floating, a weak internal pull down resistor of 100k Ω will pull the ENABLE pin below the logic level low threshold. The operational functions of this pin should follow the timing diagram outlined in [Figure 5](#). A logic level low will actively hold both Control FET and Sync FET gates low and V_{DD} pin should typically draw less than 5 μ A.

POWER UP SEQUENCING

If the ENABLE signal is used, it is necessary to ensure proper co-ordination with the ENABLE and soft-start features of the external PWM controller in the system. If the CSD97370AQ5M was disabled through ENABLE without sequencing with the PWM IC controller, the buck converter output will have no voltage or fall below regulation set point voltage. As a result, the PWM controller IC delivers Max duty cycle on the PWM line. If the Power Stage CSD97370AQ5M is re-enabled by driving the ENABLE pin high, there will be an extremely large input inrush current when the output voltage builds back up again. The input inrush current might have undesirable consequences such as inductor saturation, driving the input power supply into current limit or even catastrophic failure of the CSD97370AQ5M device. Disabling the PWM controller is recommended when the CSD97370AQ5M is disabled. The PWM controller should always be re-enabled by going through soft-start routine to control and minimize the input inrush current and reduce current and voltage stress on all buck converter components. It is recommended that the external PWM controller be disabled when CSD97370AQ5M is disabled or nonoperational because of UVLO.

PWM

The input PWM pin incorporates a 3-State function. The Control FET and Sync FET gates are forced low if the PWM pin is left floating for more than the 3-State Hold off time (t_{3HT}), typically 100ns. This requires the source impedance of the driving PWM signal to be a minimum of 250k Ω when in 3-State mode. Operation in and out of 3-State mode should follow the timing diagram outlined in [Figure 6](#). Both V_{PWML} and V_{PWMLH} threshold levels are set to accommodate 5V logic controllers. During normal operation, the PWM signal should be driven to logic levels Low and High with a maximum of 220 Ω /320 Ω sink/source impedance respectively.

GATE DRIVERS

The CSD97370AQ5M has an internal high-performance gate driver IC that ensures minimum MOSFET dead-time while eliminating potential shoot-through currents. Propagation delays between the Control FET and Sync FET gates are kept to a minimum to minimize body diode conduction and improve efficiency. The gate driver IC incorporates an adaptive shoot through protection scheme which ensures that neither MOSFET is turned on while the other one is still conducting at the same time, preventing cross conduction. See [Table 1](#).

Table 1. Truth Table

ENABLE	PWM	CONTROL FET GATE	SYNC FET GATE	V_{sw}
L	X	L	L	3-State
H	<Min ON time	L	L	3-State
H	L	L	H	P_{GND}
H	3-State	L	L	3-State
H	H	H	L	V_{IN}

L = Logic Low; H = Logic High; X = Don't care; minimum on time = 40ns

START UP IN PRE-BIASED OUTPUT VOLTAGE

The CSD97370AQ5M incorporates a simple pre-bias feature to protect against the discharging of a prebiased output voltage and inducing large negative inductor currents. After the Power On Reset threshold is crossed and the ENABLE pin is set to logic level high, both internal MOSFETs are actively held low until the PWM pin receives a signal that crosses logic level high threshold and meets the minimum on time criteria (see the *Electrical Characteristics Table*). This allows the PWM control IC to provide a soft start routine that creates a monotonic startup of the output voltage. The pre-bias feature is enabled for a single event and subsequent PWM signals creates normal switching of the internal MOSFETs (see [Table 1](#)). To reactivate the pre-bias feature, the ENABLE pin needs to be pulled below logic level low or the V_{DD} supply voltage needs to cross UVLO.

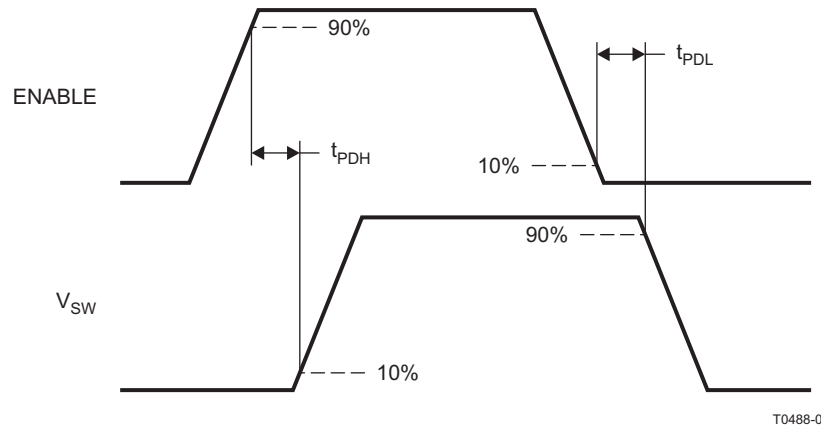

T0488-01

Figure 5. CSD97370AQ5M ENABLE Timing Diagram ($V_{DD} = PWM = 5V$)

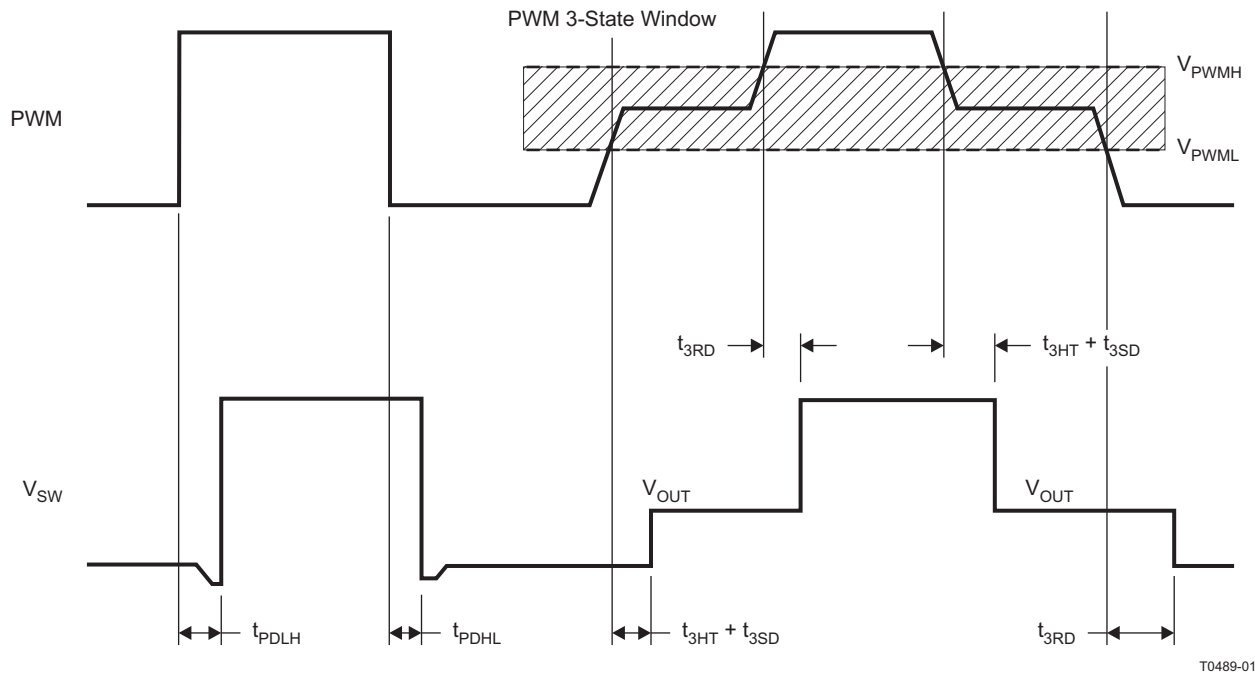

T0489-01

Figure 6. CSD97370AQ5M PWM Timing Diagram

TYPICAL CHARACTERISTICS

Test conditions: $V_{IN} = 12V$, $V_{DD} = 5V$, $f_{SW} = 500kHz$, $V_{OUT} = 1.2V$, $L_{OUT} = 0.3\mu H$, $DCR = 0.54m\Omega$, $T_J = 125^\circ C$

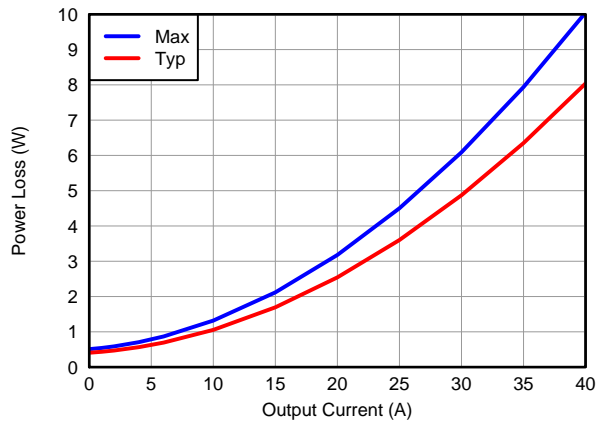

Figure 7. Power Loss vs Output Current

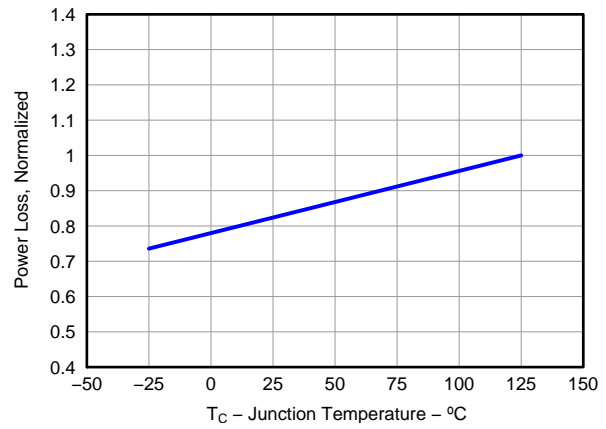

Figure 8. Power Loss vs Temperature

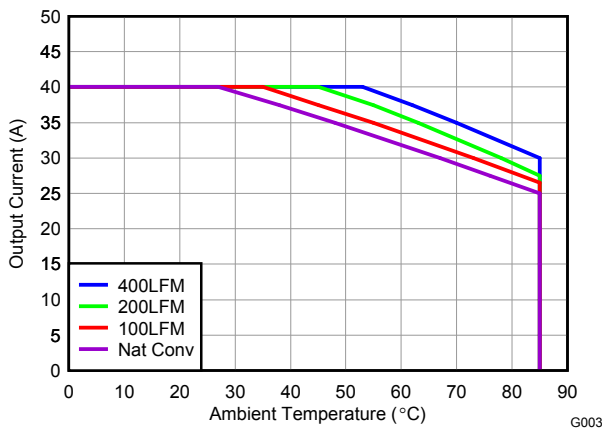

Figure 9. Safe Operating Area – PCB Vertical Mount ⁽¹⁾

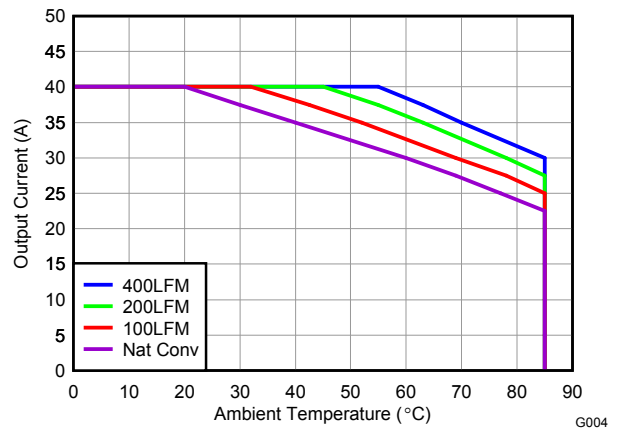

Figure 10. Safe Operating Area – PCB Horizontal Mount ⁽¹⁾

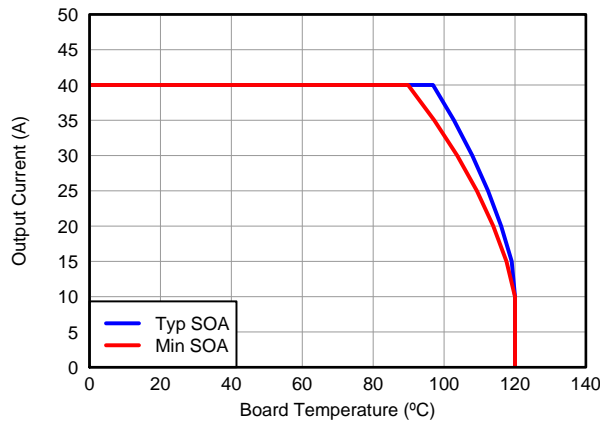

Figure 11. Typical and Min Safe Operating Area ⁽¹⁾

1. The Typical CSD97370AQ5M System Characteristic curves are based on measurements made on a PCB design with dimensions of 4.0" (W) x 3.5" (L) x 0.062" (T) and 6 copper layers of 1 oz. copper thickness. See the *Application section*

TYPICAL CHARACTERISTICS (continued)

Test conditions: $V_{IN} = 12V$, $V_{DD} = 5V$, $f_{SW} = 500kHz$, $V_{OUT} = 1.2V$, $L_{OUT} = 0.3\mu H$, $DCR = 0.54m\Omega$, $T_J = 125^\circ C$
for detailed explanation.

TYPICAL CHARACTERISTICS

Test conditions: $V_{IN} = 12V$, $V_{DD} = 5V$, $f_{SW} = 500kHz$, $V_{OUT} = 1.2V$, $L_{OUT} = 0.3\mu H$, $DCR = 0.54m\Omega$, $T_J = 125^\circ C$

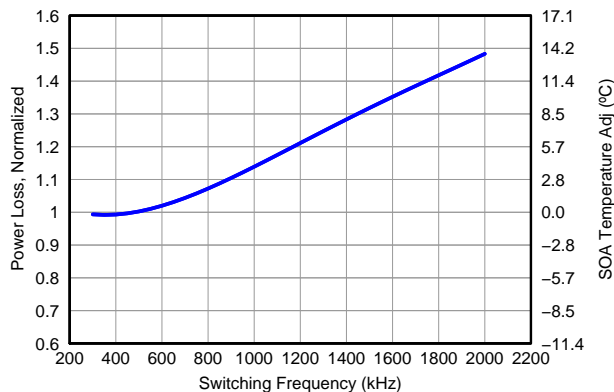

Figure 12. Normalized Power Loss vs Frequency

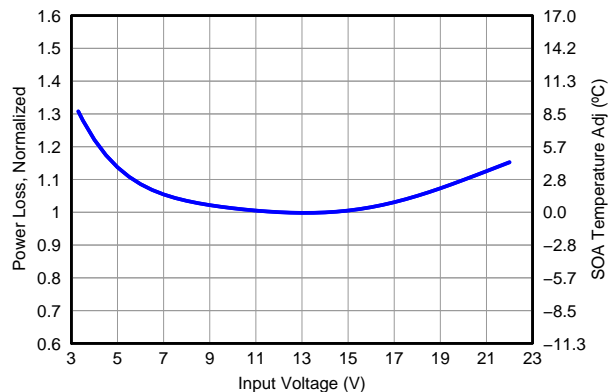

Figure 13. Normalized Power Loss vs Input Voltage

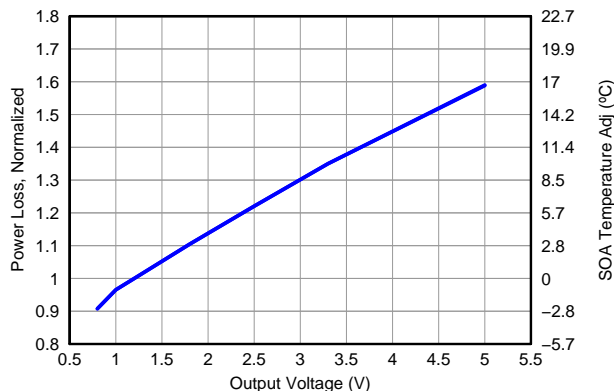

Figure 14. Normalized Power Loss vs Output Voltage

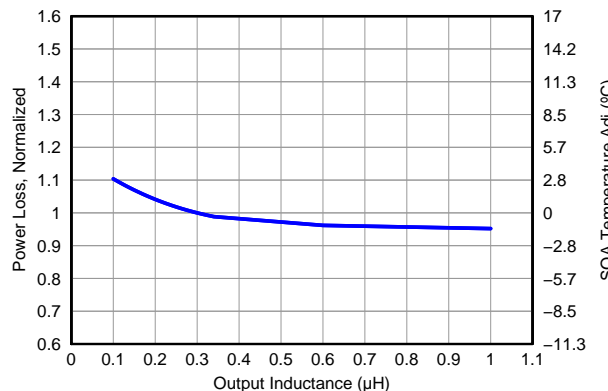

Figure 15. Normalized Power Loss vs Output Inductance

TYPICAL CHARACTERISTICS (continued)

Test conditions: $V_{IN} = 12V$, $V_{DD} = 5V$, $f_{SW} = 500kHz$, $V_{OUT} = 1.2V$, $L_{OUT} = 0.3\mu H$, $DCR = 0.54m\Omega$, $T_J = 125^\circ C$

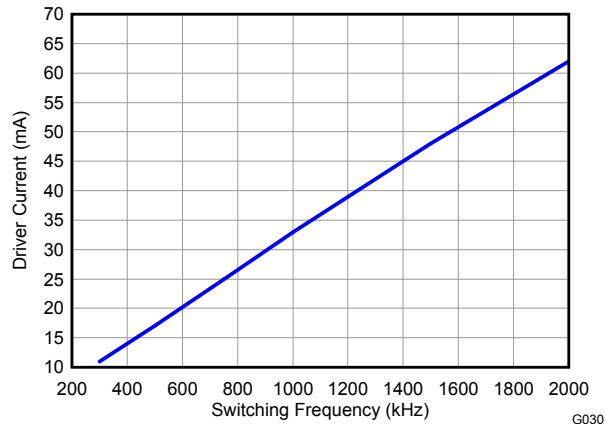

Figure 16. Driver Current vs Frequency

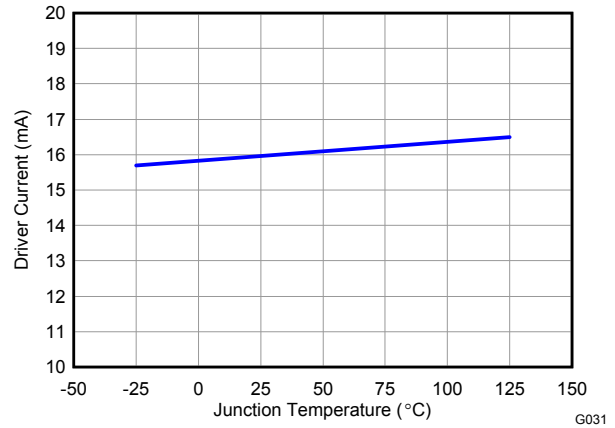

Figure 17. Driver Current vs Temperature

APPLICATION INFORMATION

The Power Stage CSD97370AQ5M is a highly optimized design for synchronous buck applications using NexFET devices with a 5V gate drive. The Control FET and Sync FET silicon are parametrically tuned to yield the lowest power loss and highest system efficiency. As a result, a rating method is used that is tailored towards a more systems centric environment. The high-performance gate driver IC integrated in the package helps minimize the parasitics and results in extremely fast switching of the power MOSFETs. System level performance curves such as Power Loss, Safe Operating Area and normalized graphs allow engineers to predict the product performance in the actual application.

Power Loss Curves

MOSFET centric parameters such as $R_{DS(ON)}$ and Q_{gd} are primarily needed by engineers to estimate the loss generated by the devices. In an effort to simplify the design process for engineers, Texas Instruments has provided measured power loss performance curves. [Figure 7](#) plots the power loss of the CSD97370AQ5M as a function of load current. This curve is measured by configuring and running the CSD97370AQ5M as it would be in the final application (see [Figure 18](#)). The measured power loss is the CSD97370AQ5M device power loss which consists of both input conversion loss and gate drive loss. [Equation 1](#) is used to generate the power loss curve.

$$\text{Power Loss} = (V_{IN} \times I_{IN}) + (V_{DD} \times I_{DD}) - (V_{SW_AVG} \times I_{OUT}) \quad (1)$$

The power loss curve in [Figure 7](#) is measured at the maximum recommended junction temperature of $T_j = 125^\circ\text{C}$ under isothermal test conditions.

Safe Operating Curves (SOA)

The SOA curves in the CSD97370AQ5M datasheet give engineers guidance on the temperature boundaries within an operating system by incorporating the thermal resistance and system power loss. [Figure 9](#), [Figure 10](#), and [Figure 11](#) outline the temperature and airflow conditions required for a given load current. The area under the curve dictates the safe operating area. All the curves are based on measurements made on a PCB design with dimensions of 4.0" (W) x 3.5" (L) x 0.062" (T) and 6 copper layers of 1 oz. copper thickness.

Normalized Curves

The normalized curves in the CSD97370AQ5M data sheet give engineers guidance on the Power Loss and SOA adjustments based on their application specific needs. These curves show how the power loss and SOA boundaries will adjust for a given set of systems conditions. The primary Y-axis is the normalized change in power loss and the secondary Y-axis is the change in system temperature required in order to comply with the SOA curve. The change in power loss is a multiplier for the Power Loss curve and the change in temperature is subtracted from the SOA curve.

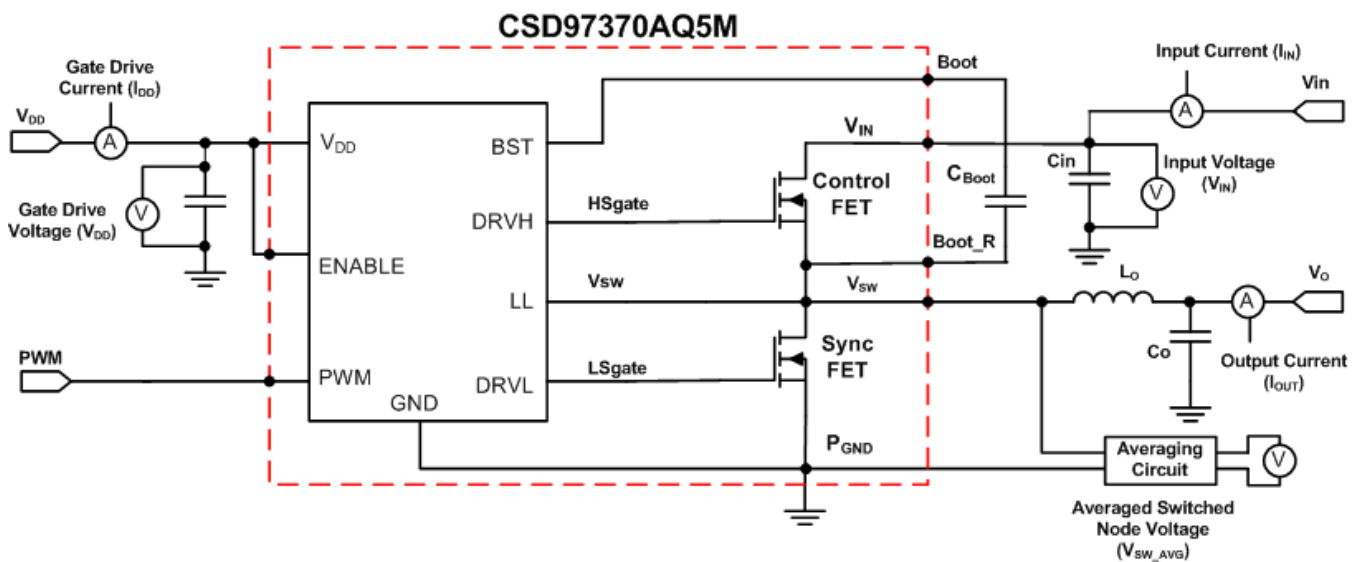

Figure 18. Power Loss Test Circuit

Calculating Power Loss and SOA

The user can estimate product loss and SOA boundaries by arithmetic means (see the Design Example). Though the Power Loss and SOA curves in this datasheet are taken for a specific set of test conditions, the following procedure will outline the steps engineers should take to predict product performance for any set of system conditions.

Design Example

Operating Conditions: Output Current (I_{OUT}) = 25A, Input Voltage (V_{IN}) = 7V, Output Voltage (V_{OUT}) = 1V, Switching Frequency (f_{SW}) = 800kHz, Output Inductor (L_{OUT}) = 0.2 μ H

Calculating Power Loss

- Typical Power Loss at 25A = 3.5W (Figure 7)
- Normalized Power Loss for switching frequency \approx 1.08 (Figure 12)
- Normalized Power Loss for input voltage \approx 1.05 (Figure 13)
- Normalized Power Loss for output voltage \approx 0.7 (Figure 14)
- Normalized Power Loss for output inductor \approx 1.04 (Figure 15)
- **Final calculated Power Loss = 3.5W \times 1.08 \times 1.05 \times 0.7 \times 1.04 \approx 2.89W**

Calculating SOA Adjustments

- SOA adjustment for switching frequency \approx 2.6°C (Figure 12)
- SOA adjustment for input voltage \approx 1.4°C (Figure 13)
- SOA adjustment for output voltage \approx -1.0°C (Figure 14)
- SOA adjustment for output inductor \approx 1.3°C (Figure 15)

- Final calculated SOA adjustment = $2.6 + 1.4 + (-1.0) + 1.3 \approx 4.3^{\circ}\text{C}$

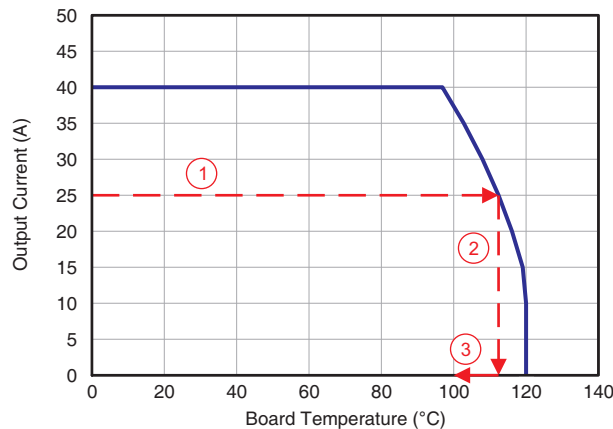

Figure 19. Power Stage CSD97370AQ5M SOA

In the design example above, the estimated power loss of the CSD97370AQ5M would increase to 2.89W. In addition, the maximum allowable board and/or ambient temperature would have to decrease by 4.3°C. Figure 19 graphically shows how the SOA curve would be adjusted accordingly.

1. Start by drawing a horizontal line from the application current to the SOA curve.
2. Draw a vertical line from the SOA curve intercept down to the board/ambient temperature.
3. Adjust the SOA board/ambient temperature by subtracting the temperature adjustment value.

In the design example, the SOA temperature adjustment yields a reduction in allowable board/ambient temperature of 4.3°C. In the event the adjustment value is a negative number, subtracting the negative number would yield an increase in allowable board/ambient temperature.

RECOMMENDED PCB DESIGN OVERVIEW

There are two key system-level parameters that can be addressed with a proper PCB design: electrical and thermal performance. Properly optimizing the PCB layout will yield maximum performance in both areas. Below is a brief description on how to address each parameter.

Electrical Performance

The CSD97370AQ5M has the ability to switch at voltages rates greater than 10kV/μs. Special care must be then taken with the PCB layout design and placement of the input capacitors, inductor and output capacitors.

- The placement of the input capacitors relative to V_{IN} and P_{GND} pins of CSD97370AQ5M device should have the highest priority during the component placement routine. It is critical to minimize these node lengths. As such, ceramic input capacitors need to be placed as close as possible to the V_{IN} and P_{GND} pins (see Figure 20). The example in Figure 20 uses 6 x 10μF 1206 25V ceramic capacitors (TDK Part # C3216X5R1C106KT or equivalent). Notice there are ceramic capacitors on both sides of the board with an appropriate amount of vias interconnecting both layers. In terms of priority of placement next to the Power Stage C5, C8 and C7, C19 should follow in order.
- The bootstrap cap C_{BOOT} 0.1μF 0603 16V ceramic capacitor should be closely connected between BOOT and BOOT_R pins
- The switching node of the output inductor should be placed relatively close to the Power Stage CSD97370AQ5M V_{SW} pins. Minimizing the V_{SW} node length between these two components will reduce the PCB conduction losses and actually reduce the switching noise level.⁽¹⁾

(1) Keong W. Kam, David Pommerenke, "EMI Analysis Methods for Synchronous Buck Converter EMI Root Cause Analysis", University of Missouri – Rolla

Thermal Performance

The CSD97370AQ5M has the ability to use the GND planes as the primary thermal path. As such, the use of thermal vias is an effective way to pull away heat from the device and into the system board. Concerns of solder voids and manufacturability problems can be addressed by the use of three basic tactics to minimize the amount of solder attach that will wick down the via barrel:

- Intentionally space out the vias from each other to avoid a cluster of holes in a given area.
- Use the smallest drill size allowed in your design. The example in [Figure 20](#) uses vias with a 10 mil drill hole and a 16 mil capture pad.
- Tent the opposite side of the via with solder-mask.

In the end, the number and drill size of the thermal vias should align with the end user's PCB design rules and manufacturing capabilities.

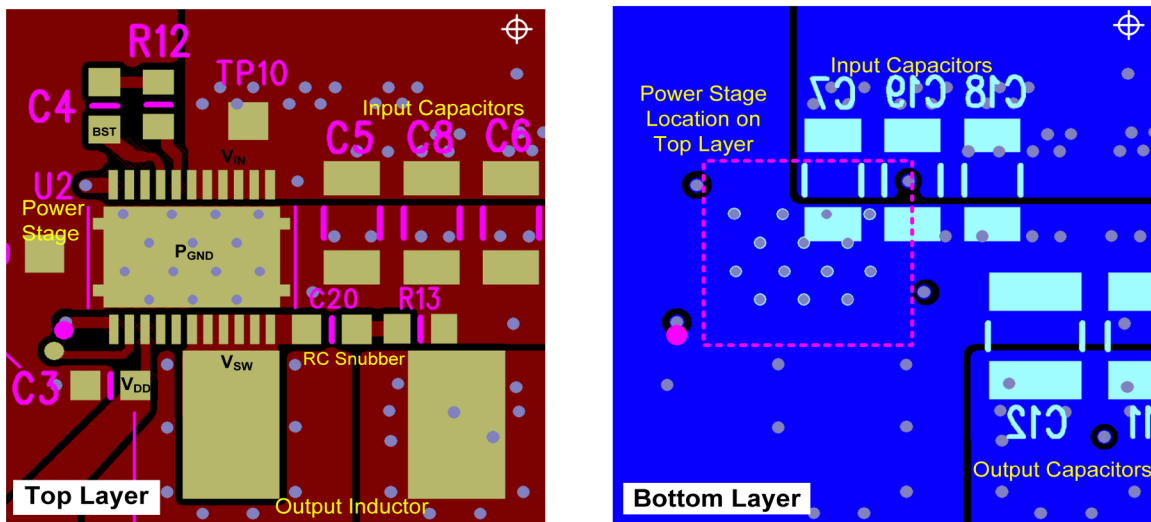

K001

Figure 20. Recommended PCB Layout (Top Down View)

MECHANICAL DATA

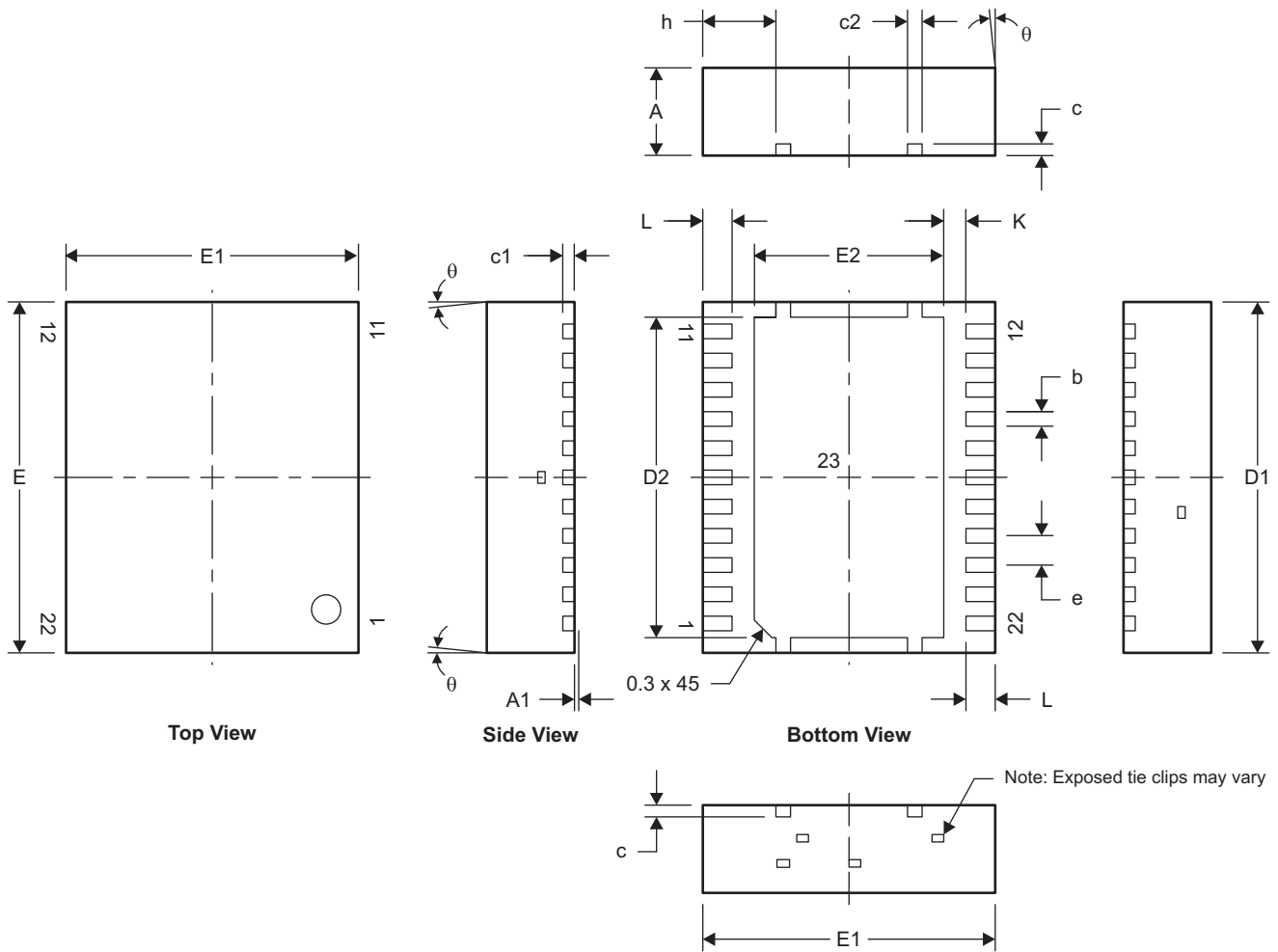

M0201-01

DIM	MILLIMETERS			INCHES		
	Min	Nom	Max	Min	Nom	Max
A	1.400	1.45	1.50	0.057	0.059	0.061
A1	0.000	0.000	0.050	0.000	0.000	0.002
b	0.200	0.250	0.320	0.008	0.010	0.013
c	0.150	0.200	0.250	0.006	0.008	0.010
c1	0.150	0.200	0.250	0.006	0.008	0.010
c2	0.200	0.250	0.300	0.008	0.010	0.012
D1	5.900	6.000	6.100	0.232	0.236	0.240
D2	5.379	5.479	5.579	0.212	0.216	0.220
E	5.900	6.000	6.100	0.232	0.236	0.240
E1	4.900	5.000	5.100	0.193	0.197	0.201
E2	3.140	3.240	3.340	0.124	0.128	0.132
e	0.500 TYP			0.020 TYP		
h	1.150	1.250	1.350	0.045	0.049	0.053
K	0.380 TYP			0.015 TYP		
L	0.400	0.500	0.600	0.016	0.020	0.024
θ	0.00	—	—	0.00	—	—

CSD97370AQ5M

SLPS352A – SEPTEMBER 2011 – REVISED MAY 2012

www.ti.com

Land Pattern Recommendation

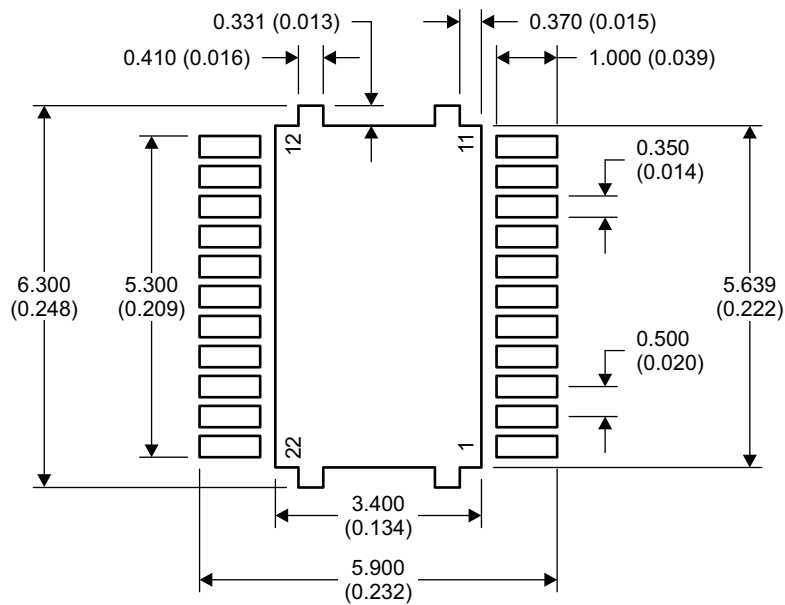

M0202-01

NOTE: Dimensions are in mm (inches).

Stencil Recommendation

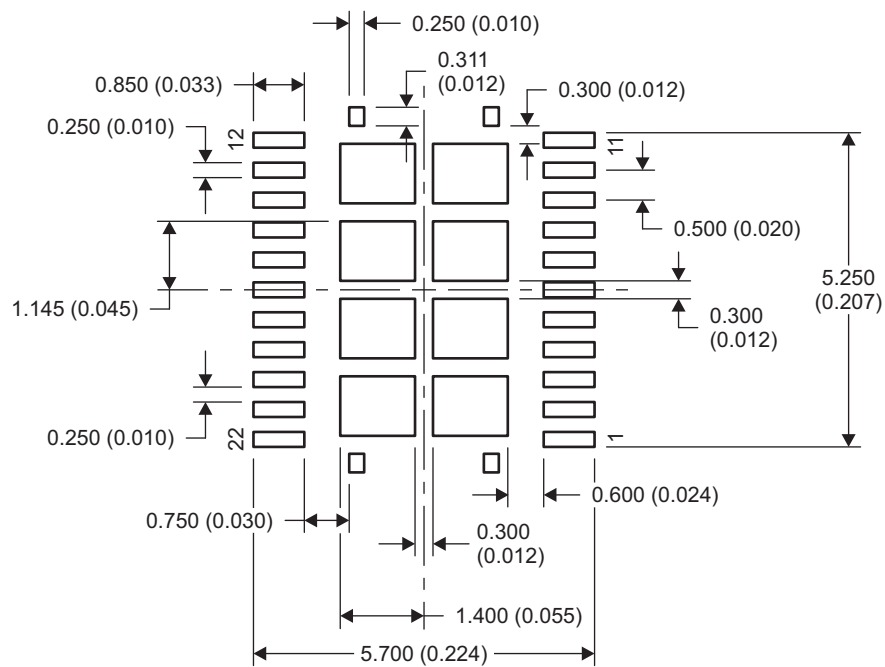

M0204-01

NOTE: Dimensions are in mm (inches).

REVISION HISTORY

Changes from Original (September 2011) to Revision A	Page
<ul style="list-style-type: none">Changed the PWM section From: to accommodate both 3.3V and 5V logic controllers To: to accommodate 5V logic controllers	6

PACKAGING INFORMATION

Orderable Device	Status (1)	Package Type	Package Drawing	Pins	Package Qty	Eco Plan (2)	Lead/Ball Finish (6)	MSL Peak Temp (3)	Op Temp (°C)	Device Marking (4/5)	Samples
CSD97370AQ5M	ACTIVE	LSON-CLIP	DQP	22	2500	Pb-Free (RoHS Exempt)	CU NIPDAU	Level-2-260C-1 YEAR	-55 to 150	97370AM	Samples

(1) The marketing status values are defined as follows:

ACTIVE: Product device recommended for new designs.

LIFEBUY: TI has announced that the device will be discontinued, and a lifetime-buy period is in effect.

NRND: Not recommended for new designs. Device is in production to support existing customers, but TI does not recommend using this part in a new design.

PREVIEW: Device has been announced but is not in production. Samples may or may not be available.

OBSELETE: TI has discontinued the production of the device.

(2) Eco Plan - The planned eco-friendly classification: Pb-Free (RoHS), Pb-Free (RoHS Exempt), or Green (RoHS & no Sb/Br) - please check <http://www.ti.com/productcontent> for the latest availability information and additional product content details.

TBD: The Pb-Free/Green conversion plan has not been defined.

Pb-Free (RoHS): TI's terms "Lead-Free" or "Pb-Free" mean semiconductor products that are compatible with the current RoHS requirements for all 6 substances, including the requirement that lead not exceed 0.1% by weight in homogeneous materials. Where designed to be soldered at high temperatures, TI Pb-Free products are suitable for use in specified lead-free processes.

Pb-Free (RoHS Exempt): This component has a RoHS exemption for either 1) lead-based flip-chip solder bumps used between the die and package, or 2) lead-based die adhesive used between the die and leadframe. The component is otherwise considered Pb-Free (RoHS compatible) as defined above.

Green (RoHS & no Sb/Br): TI defines "Green" to mean Pb-Free (RoHS compatible), and free of Bromine (Br) and Antimony (Sb) based flame retardants (Br or Sb do not exceed 0.1% by weight in homogeneous material)

(3) MSL, Peak Temp. - The Moisture Sensitivity Level rating according to the JEDEC industry standard classifications, and peak solder temperature.

(4) There may be additional marking, which relates to the logo, the lot trace code information, or the environmental category on the device.

(5) Multiple Device Markings will be inside parentheses. Only one Device Marking contained in parentheses and separated by a "~" will appear on a device. If a line is indented then it is a continuation of the previous line and the two combined represent the entire Device Marking for that device.

(6) Lead/Ball Finish - Orderable Devices may have multiple material finish options. Finish options are separated by a vertical ruled line. Lead/Ball Finish values may wrap to two lines if the finish value exceeds the maximum column width.

Important Information and Disclaimer:The information provided on this page represents TI's knowledge and belief as of the date that it is provided. TI bases its knowledge and belief on information provided by third parties, and makes no representation or warranty as to the accuracy of such information. Efforts are underway to better integrate information from third parties. TI has taken and continues to take reasonable steps to provide representative and accurate information but may not have conducted destructive testing or chemical analysis on incoming materials and chemicals. TI and TI suppliers consider certain information to be proprietary, and thus CAS numbers and other limited information may not be available for release.

In no event shall TI's liability arising out of such information exceed the total purchase price of the TI part(s) at issue in this document sold by TI to Customer on an annual basis.

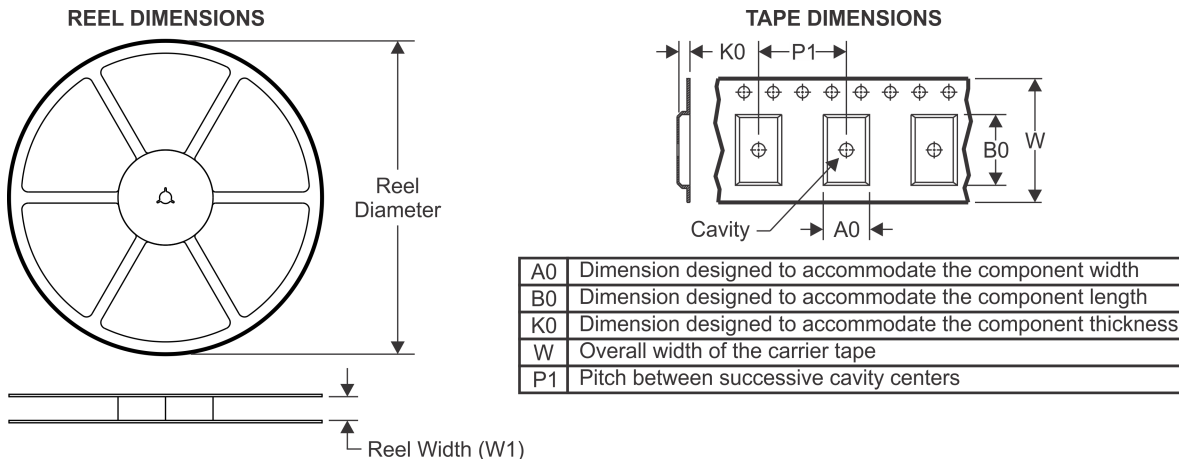
TAPE AND REEL INFORMATION

QUADRANT ASSIGNMENTS FOR PIN 1 ORIENTATION IN TAPE

*All dimensions are nominal

Device	Package Type	Package Drawing	Pins	SPQ	Reel Diameter (mm)	Reel Width W1 (mm)	A0 (mm)	B0 (mm)	K0 (mm)	P1 (mm)	W (mm)	Pin1 Quadrant
CSD97370AQ5M	LSON-CLIP	DQP	22	2500	330.0	12.4	5.3	6.3	1.8	8.0	12.0	Q1

TAPE AND REEL BOX DIMENSIONS



*All dimensions are nominal

Device	Package Type	Package Drawing	Pins	SPQ	Length (mm)	Width (mm)	Height (mm)
CSD97370AQ5M	LSON-CLIP	DQP	22	2500	367.0	367.0	35.0

DQP (R-PSON-N22)

PLASTIC SMALL OUTLINE NO-LEAD

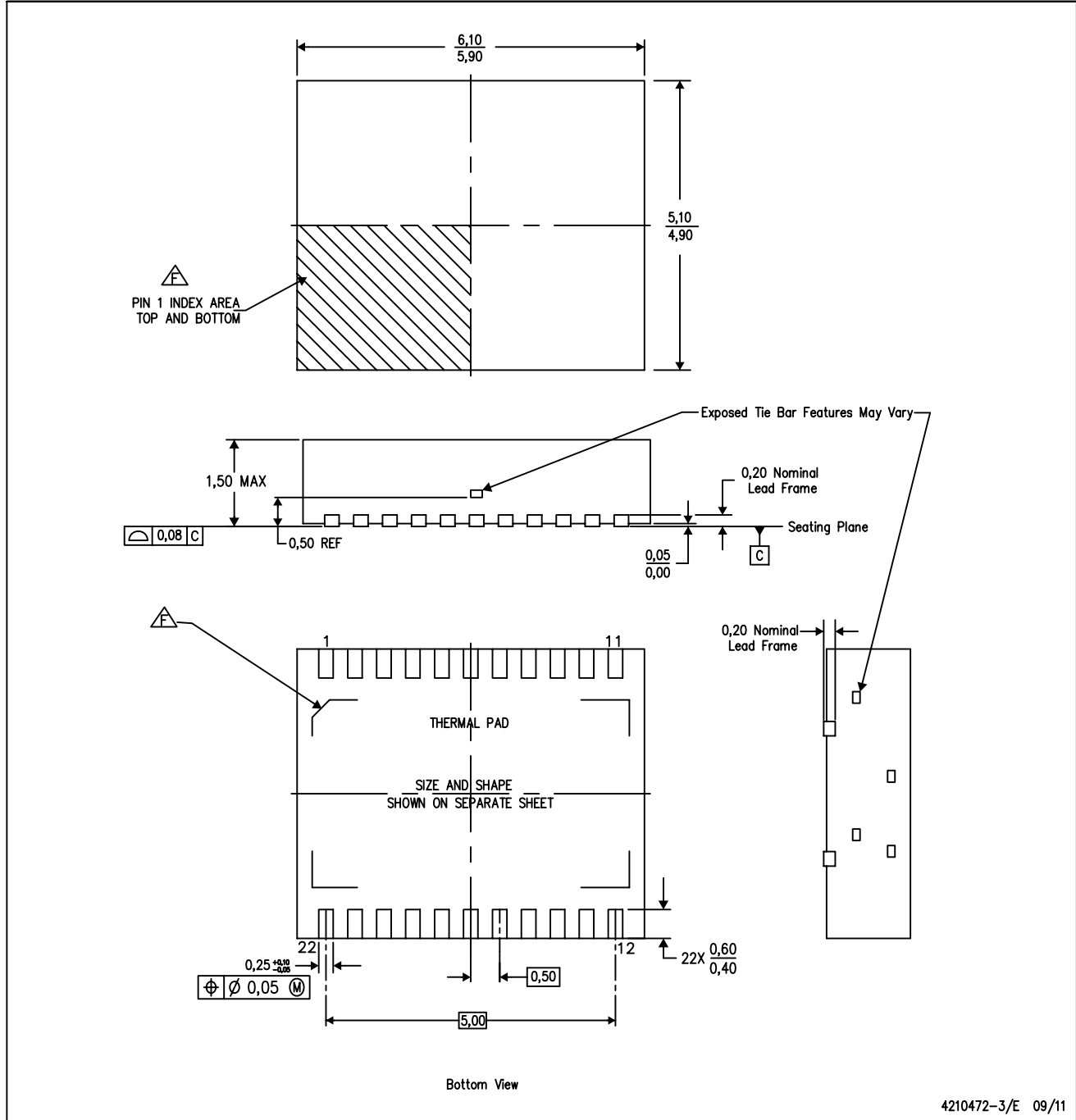

- NOTES:
- A. All linear dimensions are in millimeters. Dimensioning and tolerancing per ASME Y14.5M-1994.
 - B. This drawing is subject to change without notice.
 - C. Small Outline No-Lead (SON) package configuration.
 - D. The package thermal pad must be soldered to the board for thermal and mechanical performance.
 - E. See the additional figure in the Product Data Sheet for details regarding the exposed thermal pad features and dimensions.
 - F. Pin 1 identifiers are located on both top and bottom of the package and within the zone indicated. The Pin 1 identifiers are either a molded, marked, or metal feature.

THERMAL PAD MECHANICAL DATA

DQP (R-PSO-N22)

PLASTIC SMALL OUTLINE NO-LEAD

THERMAL INFORMATION

This package incorporates an exposed thermal pad that is designed to be attached directly to an external heatsink. The thermal pad must be soldered directly to the printed circuit board (PCB). After soldering, the PCB can be used as a heatsink. In addition, through the use of thermal vias, the thermal pad can be attached directly to the appropriate copper plane shown in the electrical schematic for the device, or alternatively, can be attached to a special heatsink structure designed into the PCB. This design optimizes the heat transfer from the integrated circuit (IC).

For information on the Quad Flatpack No-Lead (QFN) package and its advantages, refer to Application Report, QFN/SO/N PCB Attachment, Texas Instruments Literature No. SLUA271. This document is available at www.ti.com.

The exposed thermal pad dimensions for this package are shown in the following illustration.

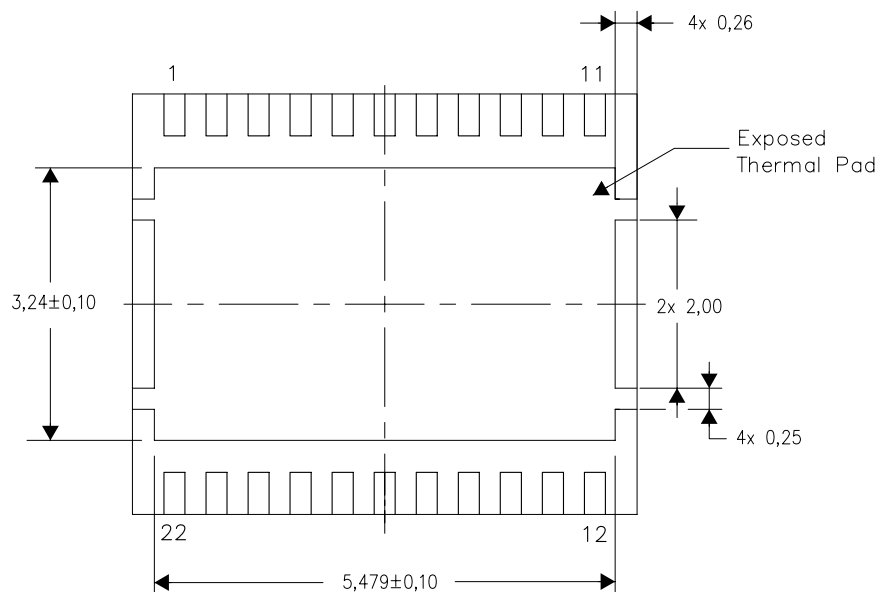

Bottom View

Exposed Thermal Pad Dimensions

4211024-3/E 03/12

NOTE: All linear dimensions are in millimeters

DQP (R-PSO-N22)

PLASTIC SMALL OUTLINE NO-LEAD

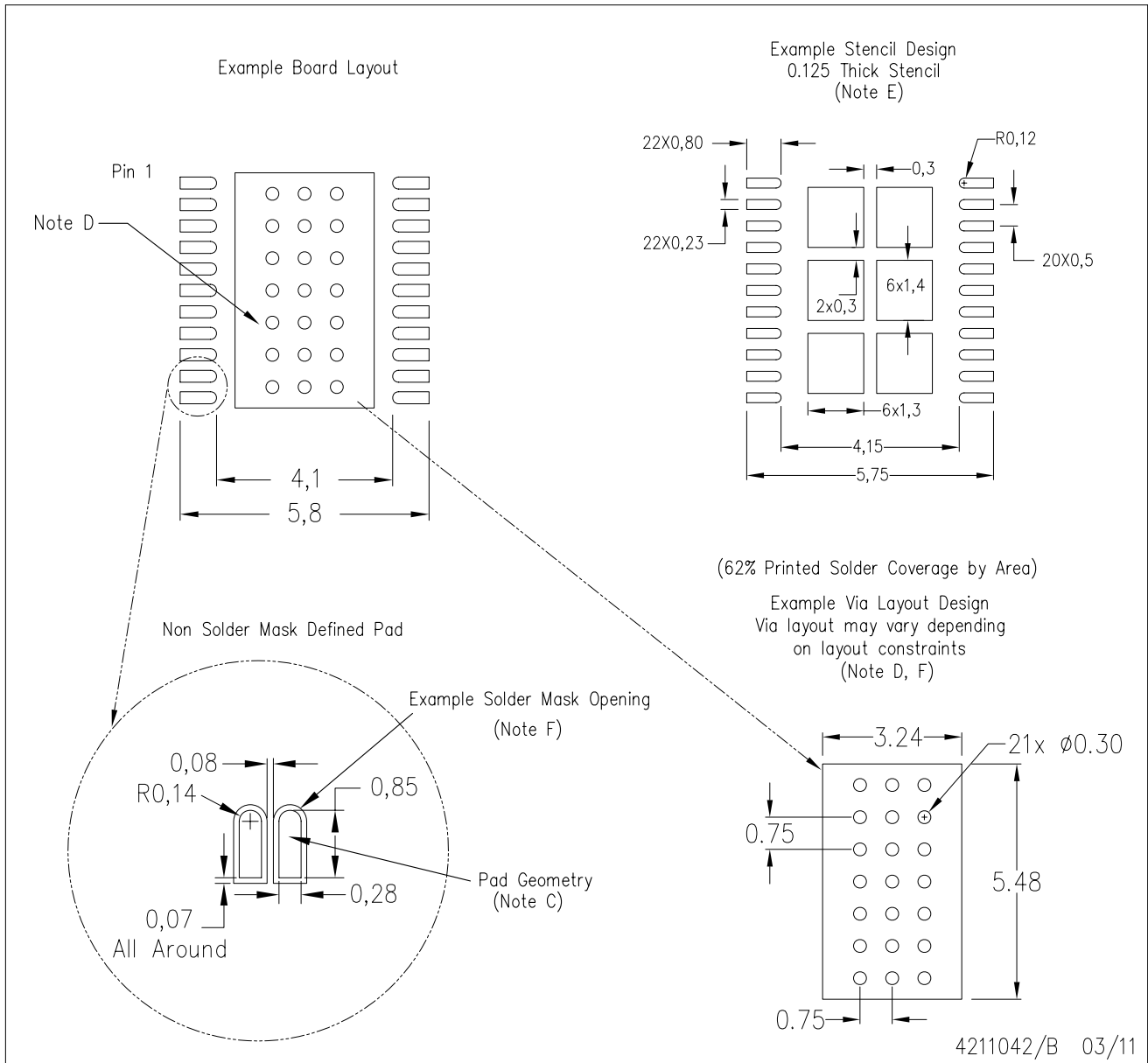

- NOTES:
- All linear dimensions are in millimeters.
 - This drawing is subject to change without notice.
 - Publication IPC-7351 is recommended for alternate designs.
 - This package is designed to be soldered to a thermal pad on the board. Refer to Application Note, QFN/SON PCB Attachment, Texas Instruments Literature No. SLUA271, and also the Product Data Sheets for specific thermal information, via requirements, and recommended board layout. These documents are available at www.ti.com <<http://www.ti.com>>.
 - Laser cutting apertures with trapezoidal walls and also rounding corners will offer better paste release. Customers should contact their board assembly site for stencil design recommendations. Refer to IPC 7525 for stencil design considerations.
 - Customers should contact their board fabrication site for recommended solder mask tolerances and via tenting recommendations for vias placed in the thermal pad.

IMPORTANT NOTICE

Texas Instruments Incorporated and its subsidiaries (TI) reserve the right to make corrections, enhancements, improvements and other changes to its semiconductor products and services per JESD46, latest issue, and to discontinue any product or service per JESD48, latest issue. Buyers should obtain the latest relevant information before placing orders and should verify that such information is current and complete. All semiconductor products (also referred to herein as "components") are sold subject to TI's terms and conditions of sale supplied at the time of order acknowledgment.

TI warrants performance of its components to the specifications applicable at the time of sale, in accordance with the warranty in TI's terms and conditions of sale of semiconductor products. Testing and other quality control techniques are used to the extent TI deems necessary to support this warranty. Except where mandated by applicable law, testing of all parameters of each component is not necessarily performed.

TI assumes no liability for applications assistance or the design of Buyers' products. Buyers are responsible for their products and applications using TI components. To minimize the risks associated with Buyers' products and applications, Buyers should provide adequate design and operating safeguards.

TI does not warrant or represent that any license, either express or implied, is granted under any patent right, copyright, mask work right, or other intellectual property right relating to any combination, machine, or process in which TI components or services are used. Information published by TI regarding third-party products or services does not constitute a license to use such products or services or a warranty or endorsement thereof. Use of such information may require a license from a third party under the patents or other intellectual property of the third party, or a license from TI under the patents or other intellectual property of TI.

Reproduction of significant portions of TI information in TI data books or data sheets is permissible only if reproduction is without alteration and is accompanied by all associated warranties, conditions, limitations, and notices. TI is not responsible or liable for such altered documentation. Information of third parties may be subject to additional restrictions.

Resale of TI components or services with statements different from or beyond the parameters stated by TI for that component or service voids all express and any implied warranties for the associated TI component or service and is an unfair and deceptive business practice. TI is not responsible or liable for any such statements.

Buyer acknowledges and agrees that it is solely responsible for compliance with all legal, regulatory and safety-related requirements concerning its products, and any use of TI components in its applications, notwithstanding any applications-related information or support that may be provided by TI. Buyer represents and agrees that it has all the necessary expertise to create and implement safeguards which anticipate dangerous consequences of failures, monitor failures and their consequences, lessen the likelihood of failures that might cause harm and take appropriate remedial actions. Buyer will fully indemnify TI and its representatives against any damages arising out of the use of any TI components in safety-critical applications.

In some cases, TI components may be promoted specifically to facilitate safety-related applications. With such components, TI's goal is to help enable customers to design and create their own end-product solutions that meet applicable functional safety standards and requirements. Nonetheless, such components are subject to these terms.

No TI components are authorized for use in FDA Class III (or similar life-critical medical equipment) unless authorized officers of the parties have executed a special agreement specifically governing such use.

Only those TI components which TI has specifically designated as military grade or "enhanced plastic" are designed and intended for use in military/aerospace applications or environments. Buyer acknowledges and agrees that any military or aerospace use of TI components which have **not** been so designated is solely at the Buyer's risk, and that Buyer is solely responsible for compliance with all legal and regulatory requirements in connection with such use.

TI has specifically designated certain components as meeting ISO/TS16949 requirements, mainly for automotive use. In any case of use of non-designated products, TI will not be responsible for any failure to meet ISO/TS16949.

Products

Audio	www.ti.com/audio
Amplifiers	amplifier.ti.com
Data Converters	dataconverter.ti.com
DLP® Products	www.dlp.com
DSP	dsp.ti.com
Clocks and Timers	www.ti.com/clocks
Interface	interface.ti.com
Logic	logic.ti.com
Power Mgmt	power.ti.com
Microcontrollers	microcontroller.ti.com
RFID	www.ti-rfid.com
OMAP Applications Processors	www.ti.com/omap
Wireless Connectivity	www.ti.com/wirelessconnectivity

Applications

Automotive and Transportation	www.ti.com/automotive
Communications and Telecom	www.ti.com/communications
Computers and Peripherals	www.ti.com/computers
Consumer Electronics	www.ti.com/consumer-apps
Energy and Lighting	www.ti.com/energy
Industrial	www.ti.com/industrial
Medical	www.ti.com/medical
Security	www.ti.com/security
Space, Avionics and Defense	www.ti.com/space-avionics-defense
Video and Imaging	www.ti.com/video

TI E2E Community

e2e.ti.com

Looking for pricing, stock, or lifecycle information?

Click below to explore more details on WIN SOURCE:

 [View CSD97370AQ5M on WIN SOURCE](#)

 [Texas Instruments](#) Information

Optimize Your Supply Chain with WIN SOURCE Solutions

-  Global Sourcing Solution
-  Obsolete Management
-  Cost Control Management
-  Shortage Management
-  Alternative Solution
-  Excess Inventory Management