



**THE DATASHEET OF
BD63282EFV-E2**



DC Brushless Fan Motor Driver Series

Three-phase Full-wave Fan Motor Driver

BD63282EFV

General Description

BD63282EFV is a 1chip driver composed of a Power DMOS FET motor driver. This IC implements a stable start-up by rotor position detection with 3 hall element. Furthermore, it introduces silent operation and low vibration by making output current a sine-wave that achieves.

Features

- Small Package
- Driver Including Power DMOS FET
- 3 Hall Sine Drive
- Speed Controllable by DC/PWM Input
- Lead Angle Control (Auto/Fixed)
- Soft-Start Function
- Rotation Direction Select
- Rotation Speed Pulse Signal Output (FG)
- Protection Function
(Under Voltage Protection Function, Lock Protection Function (Automatic Recovery Function), High Speed Rotation Protection Function, Low Speed Rotation Protection Function)

Application

- Fan Motors for General Consumer Equipment of Refrigerator etc.

Key Specifications

- Operating Supply Voltage Range: 5.0 V to 16.0 V
- Operating Temperature Range: -40 °C to +100 °C
- Output Voltage
(High Side and Low Side Voltage Total):
0.3 V(Typ) at ±0.3 A

Package

HTSSOP-B20

W(Typ) x D(Typ) x H(Max)

6.50 mm x 6.40 mm x 1.00 mm

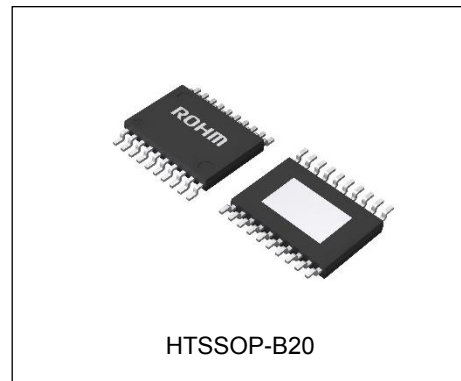

Typical Application Circuit

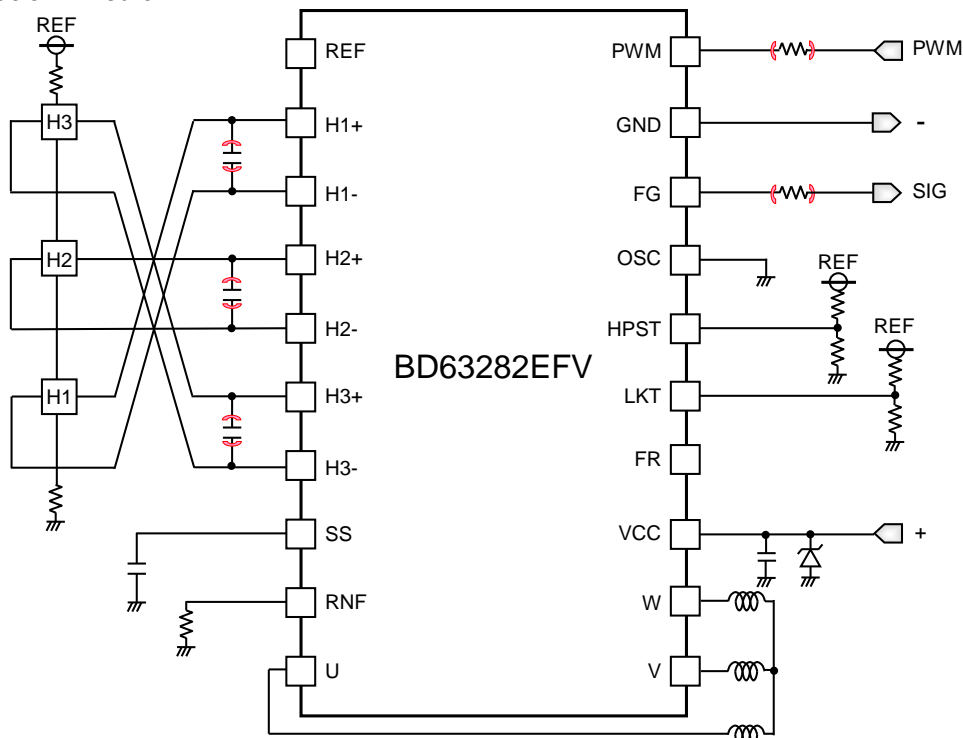

○Product structure : Silicon integrated circuit ○This product has no designed protection against radioactive rays

Contents

General Description	1
Features.....	1
Application	1
Key Specifications	1
Package.....	1
Typical Application Circuit	1
Contents	2
Pin Configuration	3
Pin Descriptions.....	3
Block Diagram	4
Absolute Maximum Ratings	5
Thermal Resistance.....	5
Recommended Operating Conditions.....	5
Electrical Characteristics.....	6
Typical Performance Curves.....	8
Application Examples	13
Description of Function Operations.....	14
Thermal Resistance Model	21
I/O Equivalence Circuits.....	22
Note for Content	22
Operational Notes.....	23
Ordering Information.....	25
Marking Diagram	25
Physical Dimension and Packing Information	26
Revision History.....	27

Pin Configuration

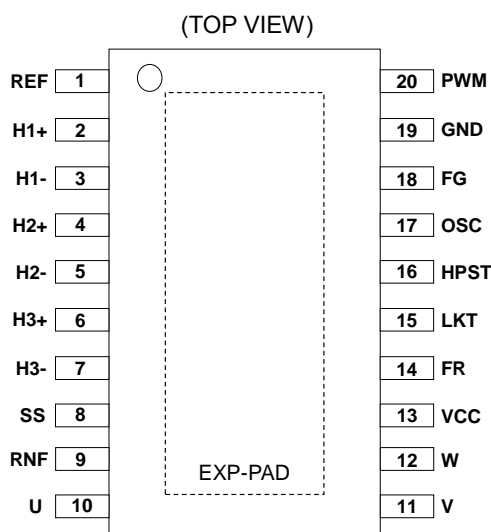

Pin Descriptions

Pin No.	Pin Name	Function
1	REF	Reference voltage output pin
2	H1+	Hall input 1 + pin
3	H1-	Hall input 1 - pin
4	H2+	Hall input 2 + pin
5	H2-	Hall input 2 - pin
6	H3+	Hall input 3 + pin
7	H3-	Hall input 3 - pin
8	SS	Oscillating capacitor connection pin for Soft-Start time setting
9	RNF	Output current detection resistor connection pin
10	U	Output U pin
11	V	Output V pin
12	W	Output W pin
13	VCC	Power supply pin
14	FR	Motor rotation direction setting pin
15	LKT	Lock off time setting pin
16	HPST	Lead angle control setting pin
17	OSC	Oscillating capacitor connection pin for OSC frequency setting
18	FG	Rotating speed pulse signal output pin
19	GND	Ground pin
20	PWM	Output duty control pin
Reverse	EXP-PAD	Substrate (Connect to Ground)

Block Diagram

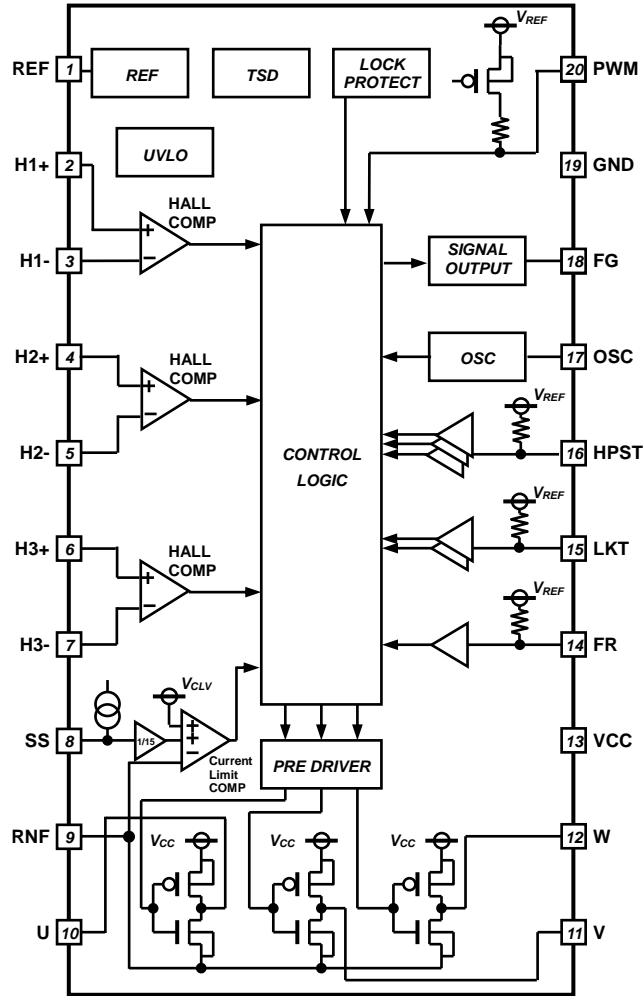

Absolute Maximum Ratings (Ta=25 °C)

Parameter	Symbol	Rating	Unit
Supply Voltage (VCC)	V _{CC}	20	V
Storage Temperature Range	T _{stg}	-55 to +150	°C
Output Voltage (U, V, W)	V _O	20	V
Output Current (U, V, W)	I _O	1.0 ^(Note 1)	A
FG Output Voltage	V _{FG}	20	V
FG Output Current	I _{FG}	10	mA
Reference Voltage (REF) Output Current	I _{REF}	10	mA
Input Voltage 1 (PWM, HPST, LKT, OSC, SS, FR, H2+, H2-, H3+, H3-)	V _{IN1}	7	V
Input Voltage 2 (H1+, H1-)	V _{IN2}	7	V
Input Voltage 3 (RNF)	V _{IN3}	4.5	V
Maximum Junction Temperature	T _{jmax}	150	°C

Caution 1: Operating the IC over the absolute maximum ratings may damage the IC. The damage can either be a short circuit between pins or an open circuit between pins and the internal circuitry. Therefore, it is important to consider circuit protection measures, such as adding a fuse, in case the IC is

Caution 2: Should by any chance the maximum junction temperature rating be exceeded the rise in temperature of the chip may result in deterioration of the properties of the chip. In case of exceeding this absolute maximum rating, design a PCB with thermal resistance taken into consideration by increasing board size and copper area so as not to exceed the maximum junction temperature rating.

(Note 1) Do not exceed T_{jmax}

Thermal Resistance^(Note 2)

Parameter	Symbol	Thermal Resistance (Typ)		Unit
		1s ^(Note 4)	2s2p ^(Note 5)	
HTSSOP-B20				
Junction to Ambient	θ _{JA}	143.0	26.8	°C/W
Junction to Top Characterization Parameter ^(Note 3)	Ψ _{JT}	8	4	°C/W

(Note 2) Based on JESD51-2A(Still-Air).

(Note 3) The thermal characterization parameter to report the difference between junction temperature and the temperature at the top center of the surface of the outside component package.

(Note 4) Using a PCB board based on JESD51-3.

(Note 5) Using a PCB board based on JESD51-5, 7.

Layer Number of Measurement Board	Material	Board Size
Single	FR-4	114.3 mm x 76.2 mm x 1.57 mmt

Top	
Copper Pattern	Thickness
Footprints and Traces	70 μm

Layer Number of Measurement Board	Material	Board Size	Thermal Via ^(Note 6)	
			Pitch	Diameter
4 Layers	FR-4	114.3 mm x 76.2 mm x 1.6 mmt	1.20 mm	Φ0.30 mm

Top		2 Internal Layers		Bottom	
Copper Pattern	Thickness	Copper Pattern	Thickness	Copper Pattern	Thickness
Footprints and Traces	70 μm	74.2 mm x 74.2 mm	35 μm	74.2 mm x 74.2 mm	70 μm

(Note 6) This thermal via connects with the copper pattern of all layers.

Recommended Operating Conditions

Parameter	Symbol	Min	Typ	Max	Unit
Supply Voltage (VCC)	V _{CC}	5	12	16	V
Input Voltage 1 (PWM, HPST, LKT, OSC, SS, FR, H2+, H2-, H3+, H3-)	V _{IN1}	0	-	V _{REF}	V
Input Voltage 2 (H1+, H1-)	V _{IN2}	0	-	2.5	V
Input Frequency (PWM)	f _{PWM}	20	-	50	kHz
Operating Temperature	T _{opr}	-40	-	+100	°C

Electrical Characteristics (Unless otherwise specified $V_{CC}=12\text{ V}$ $T_a=25\text{ }^\circ\text{C}$)

Parameter	Symbol	Min	Typ	Max	Unit	Conditions
Circuit Current	I_{CC}	4.2	7.0	9.8	mA	
<REF>						
Reference Voltage	V_{REF}	4.65	5.00	5.35	V	$I_{REF}=-2\text{ mA}$
<OSC>						
OSC High Voltage	V_{OSCH}	2.3	2.5	2.7	V	
OSC Low Voltage	V_{OSCL}	0.8	1.0	1.2	V	
OSC Charge Current	I_{COSC}	-55	-40	-25	μA	$V_{OSC}=1.8\text{ V}$
OSC Discharge Current	I_{DOSC}	+25	+40	+55	μA	$V_{OSC}=1.8\text{ V}$
<FG>						
FG Output Low Voltage	V_{FGL}	-	0.3	0.4	V	$I_{FG}=+5\text{ mA}$
FG Output Leak Current	I_{FGL}	-	-	10	μA	$V_{FG}=20\text{ V}$
<PWM>						
PWM Input High Voltage	V_{PWMH}	2.5	-	V_{REF}	V	Speed Control with PWM Input $V_{OSC}=0\text{ V}$
PWM Input Low Voltage	V_{PWML}	0.0	-	0.8	V	Speed Control with PWM Input $V_{OSC}=0\text{ V}$
PWM Input Bias Current 1	I_{PWM1}	-75	-50	-25	μA	Speed Control with PWM Input $V_{OSC}=0\text{ V}$, $V_{PWM}=0\text{ V}$
PWM Input Bias Current 2	I_{PWM2}	-1	-	-	μA	Speed Control with DC Voltage $V_{PWM}=0\text{ V}$
<Soft-Start>						
SS Charge Current	I_{SS}	-2.4	-1.8	-1.2	μA	
<Current Limit>						
Current Limit Setting Voltage	V_{CLV}	120	150	180	mV	
<Output>						
Output Voltage	V_O	-	0.3	0.4	V	$I_O=\pm 300\text{ mA}$, High and low side output voltage total
Output High Voltage	V_{OH}	-0.20	-0.15	-	V	$I_O=-300\text{ mA}$, for V_{CC} Voltage
Output Low Voltage	V_{OL}	-	0.15	0.20	V	$I_O=+300\text{ mA}$
<Lead Angle Control Setting>						
HPST Input Current	I_{HPST}	-35	-25	-15	μA	$V_{HPST}=0\text{ V}$
Auto Lead Angle Control Mode	V_{HPST1}	3.85	-	V_{REF}	V	
Fixed Lead Angle Control 25° Mode	V_{HPST2}	2.60	-	3.65	V	
Fixed Lead Angle Control 10° Mode	V_{HPST3}	1.35	-	2.40	V	
Fixed Lead Angle Control 0° Mode	V_{HPST4}	0.00	-	1.15	V	
<FR>						
FR Input Current	I_{FR}	-35	-25	-15	μA	$V_{FR}=0\text{ V}$
Forward Rotation Mode	V_{FRH}	3.8	-	V_{REF}	V	
Reverse Rotation Mode	V_{FRL}	0.0	-	0.8	V	

For parameters involving current, positive notation means inflow of current to the IC while negative notation means outflow of current from the IC

Electrical Characteristics – Continued (Unless Otherwise Specified $V_{CC}=12\text{ V}$ $T_a=25\text{ }^\circ\text{C}$)

Parameter	Symbol	Min	Typ	Max	Unit	Conditions
<Lock Detection>						
Lock Detection ON Time	t_{ON}	0.6	1.0	1.6	s	Sine start-up section
Lock Detection OFF Time 1	t_{OFF1}	2.5	5.0	7.5	s	$V_{LKT}=\text{Open}$
Lock Detection OFF Time 2	t_{OFF2}	1.0	2.0	3.0	s	$V_{LKT}=0\text{ V}$
Lock Detection OFF Time 3	t_{OFF3}	5.0	10.0	15.0	s	$V_{LKT}=1.5\text{ V}$
<LKT>						
LKT Input Bias Current	I_{LKT}	-70	-50	-35	μA	$V_{LKT}=0\text{ V}$
t_{OFF1} Mode	V_{LKT1}	2.2	-	V_{REF}	V	
t_{OFF2} Mode	V_{LKT2}	1.2	-	1.8	V	
t_{OFF3} Mode	V_{LKT3}	0.0	-	0.8	V	
<Hall Input>						
Hall Input Hysteresis Voltage +	V_{HYS+}	+5	+10	+15	mV	
Hall Input Hysteresis Voltage -	V_{HYS-}	-15	-10	-5	mV	

For parameters involving current, positive notation means inflow of current to the IC while negative notation means outflow of current from the IC

Typical Performance Curves

(Reference Data)

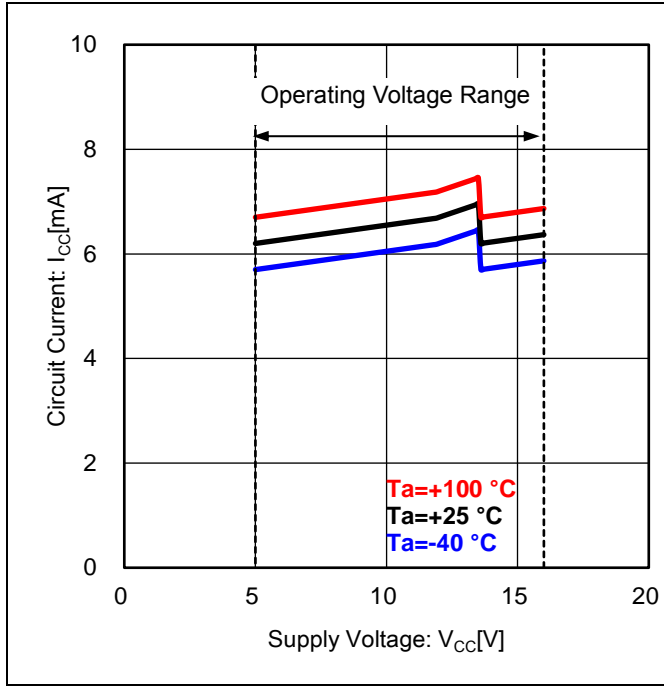

Figure 1. Circuit Current vs Supply Voltage

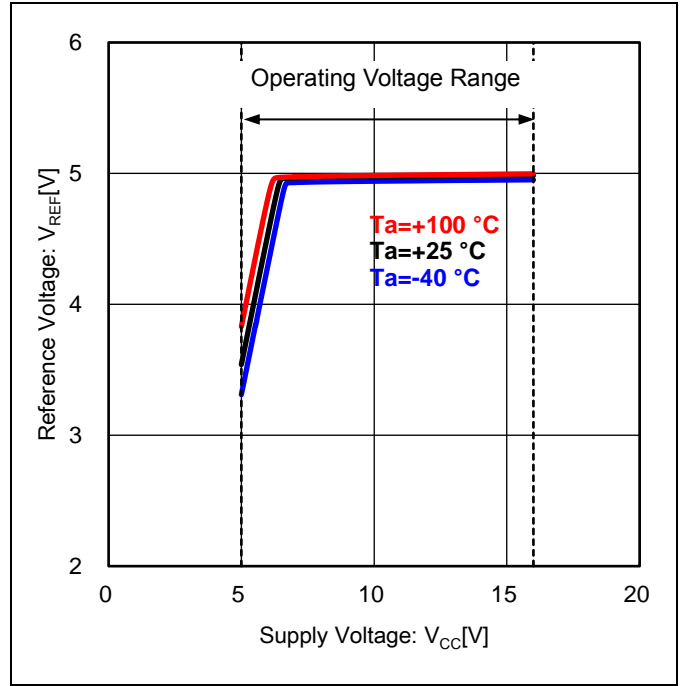

Figure 2. Reference Voltage vs Supply Voltage

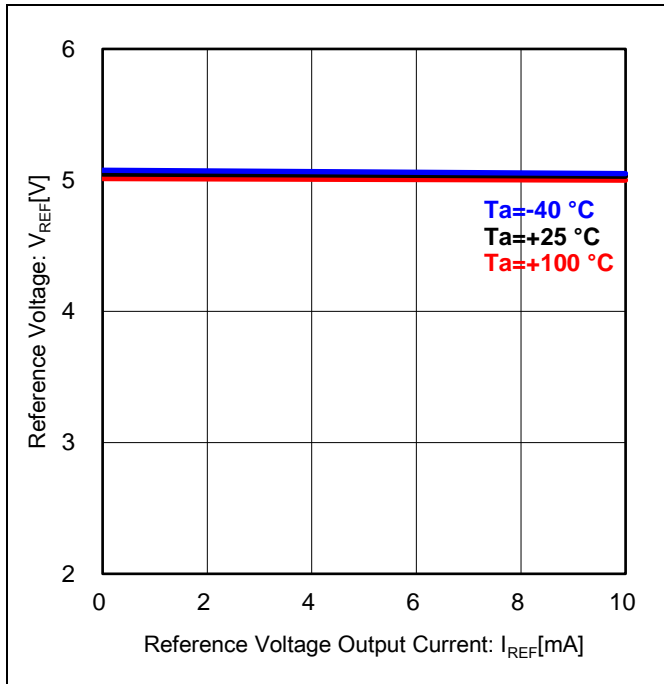

Figure 3. Reference Voltage vs Reference Voltage Output Current (Vcc=12 V)

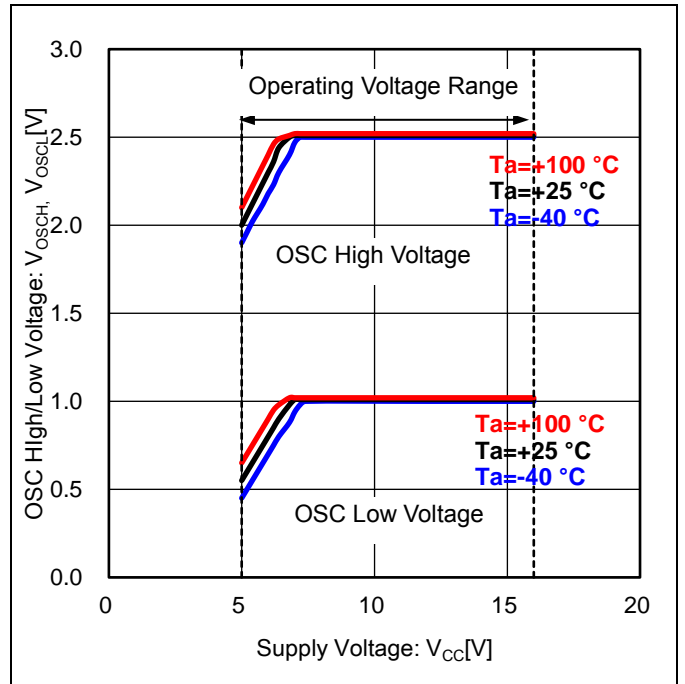

Figure 4. OSC High/Low Voltage vs Supply Voltage

Typical Performance Curves - continued
(Reference Data)

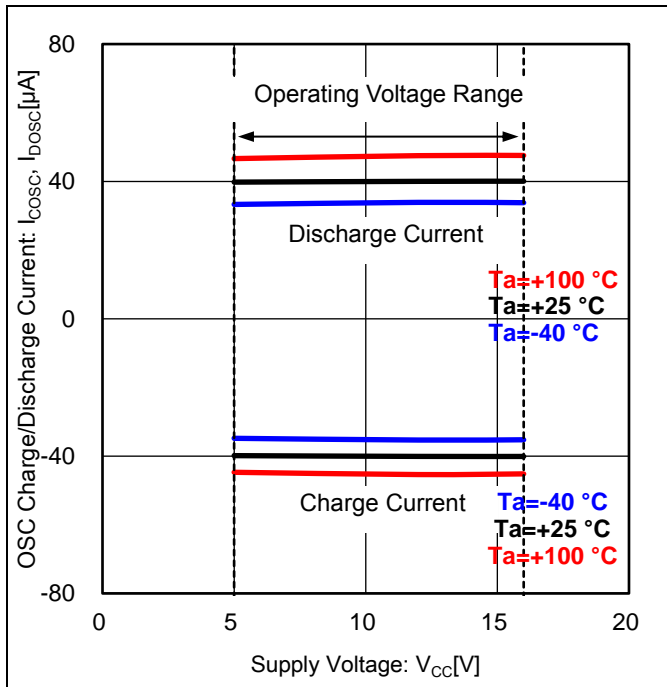

Figure 5. OSC Charge/Discharge Current vs Supply Voltage

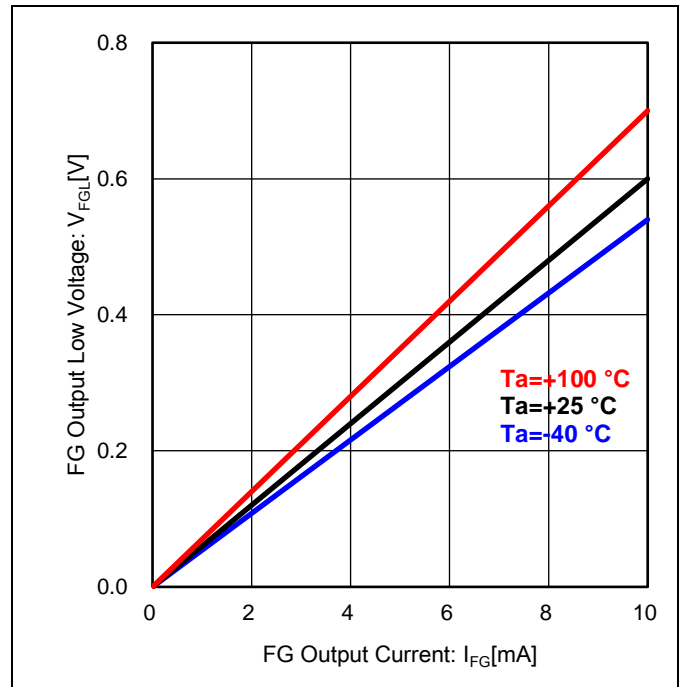

Figure 6. FG Output Low Voltage vs FG Output Current (V_{cc}=12 V)

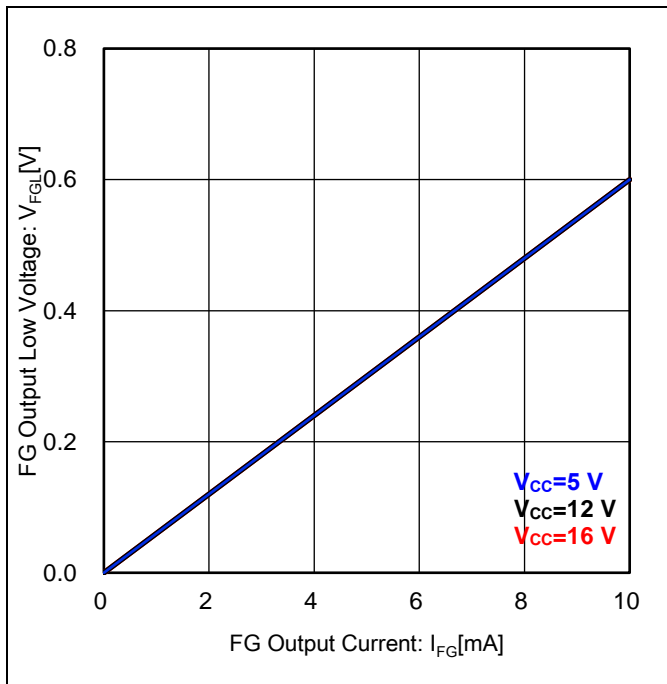

Figure 7. FG Output Low Voltage vs FG Output Current (Ta=25°C)

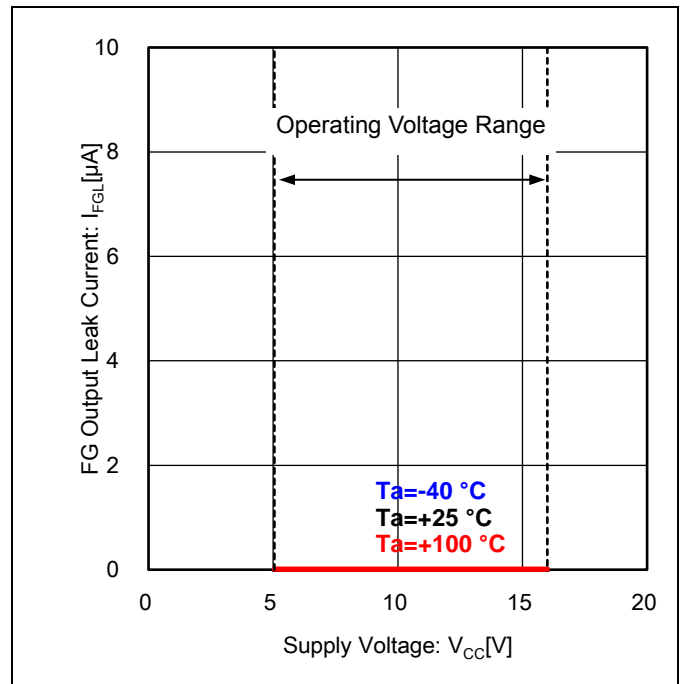

Figure 8. FG Output Leak Current vs Supply Voltage

Typical Performance Curves - continued
(Reference Data)

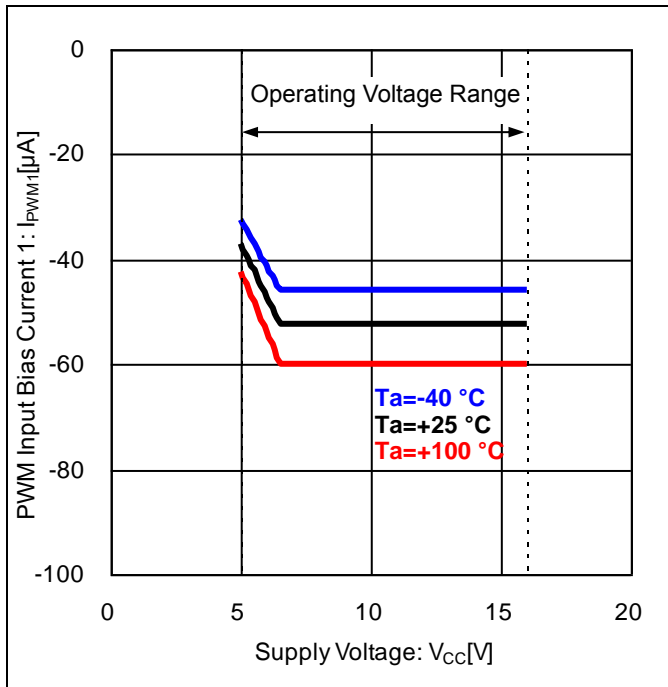

Figure 9. PWM Input Bias Current 1 vs Supply Voltage

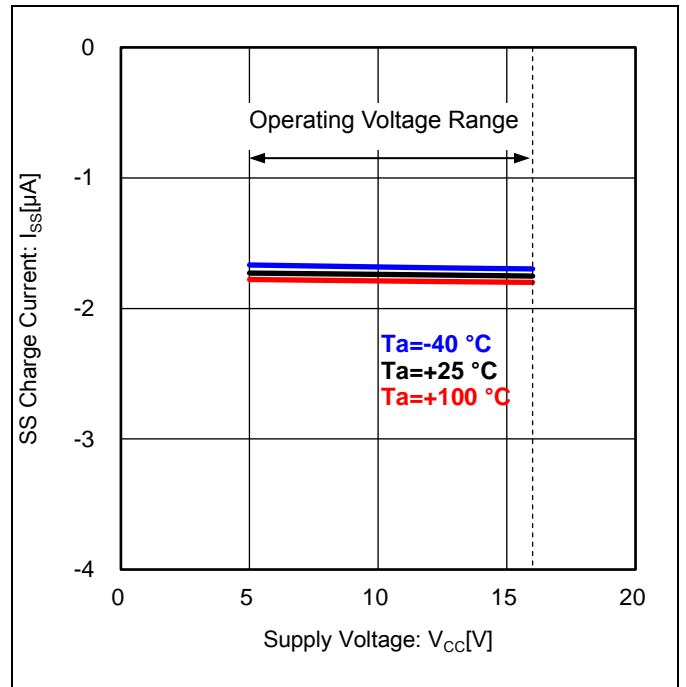

Figure 10. SS Charge Current vs Supply Voltage

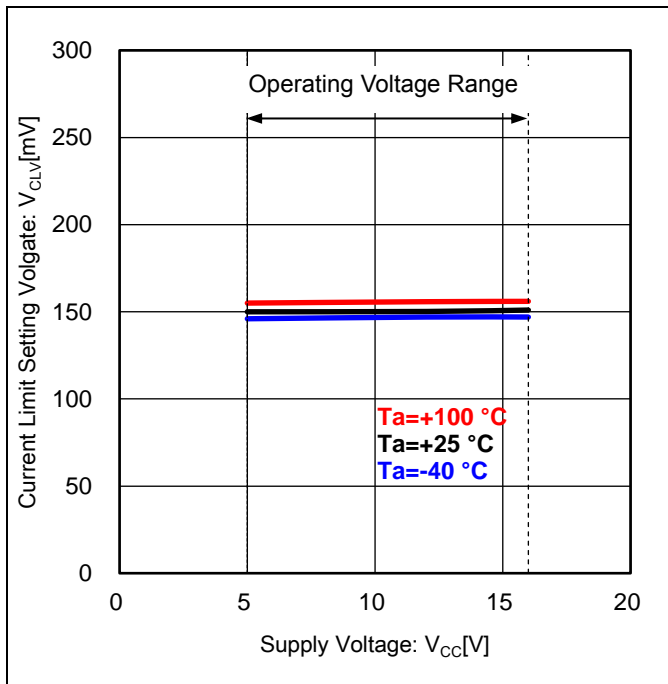

Figure 11. Current Limit Setting Voltage vs Supply Voltage

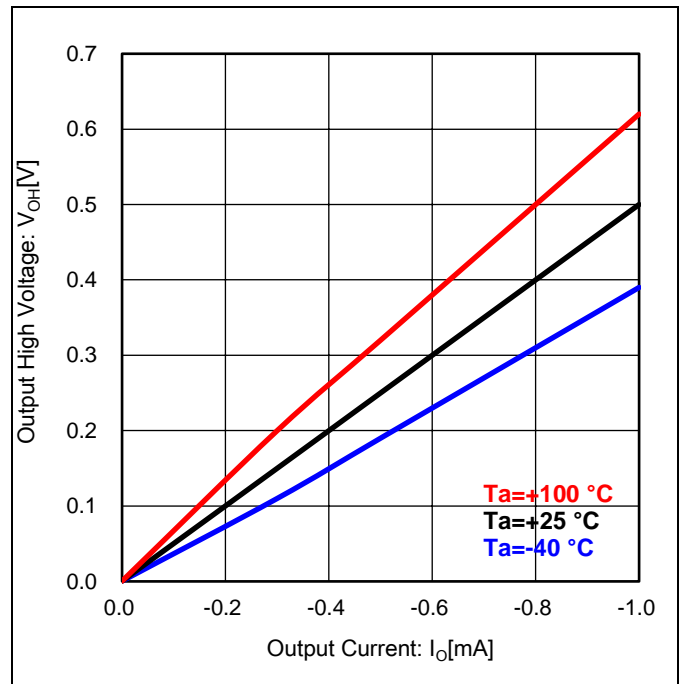

Figure 12. Output High Voltage vs Output Current (Vcc=12 V)

Typical Performance Curves - continued
(Reference Data)

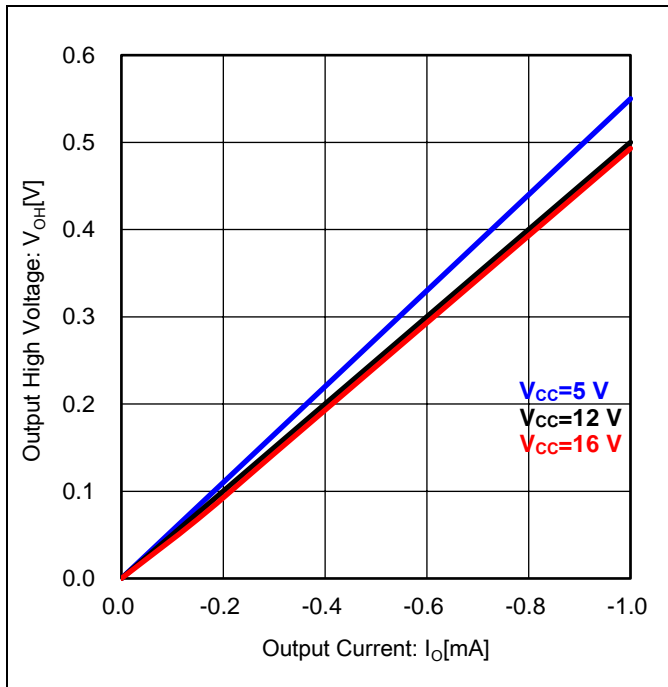

Figure 13. Output High Voltage vs Output Current
(Ta=25 °C)

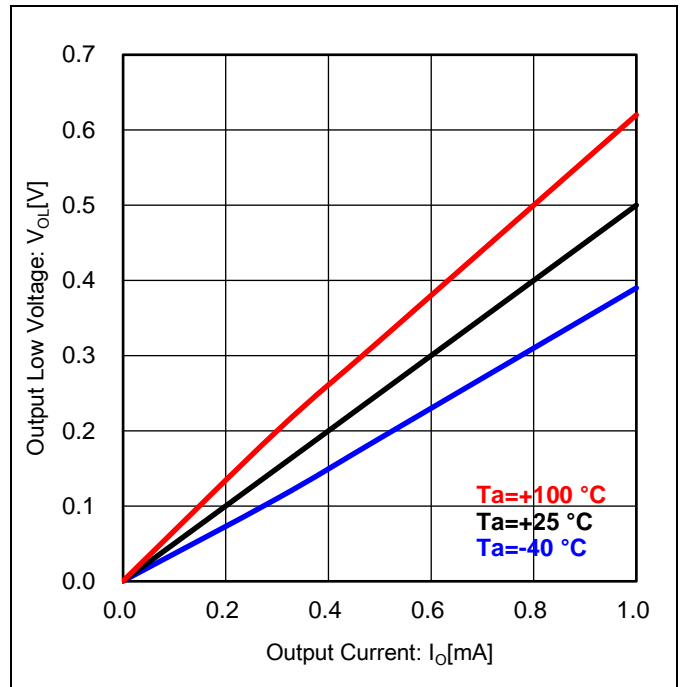

Figure 14. Output Low Voltage vs Output Current
(Vcc=12 V)

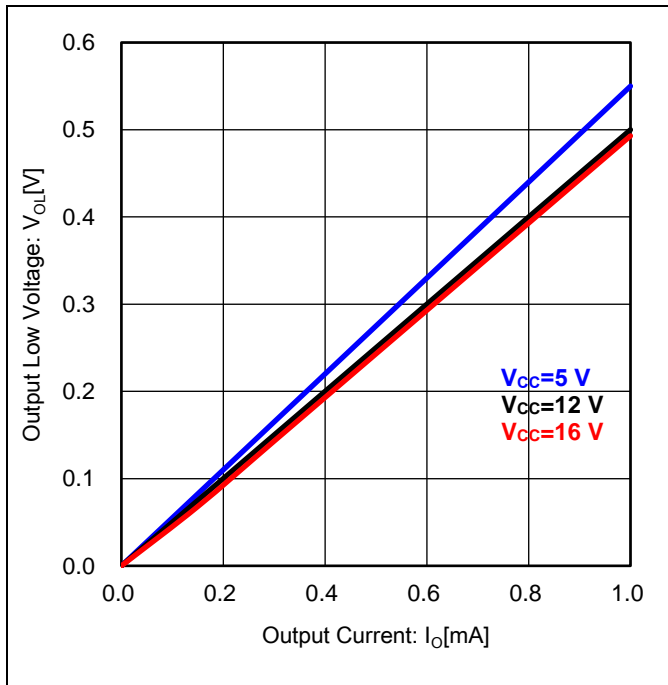

Figure 15. Output Low Voltage vs Output Current
(Ta=25 °C)

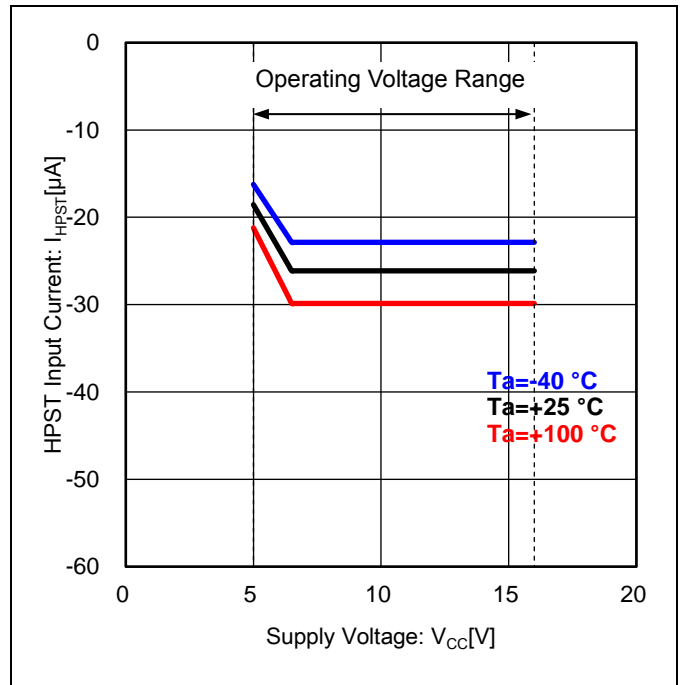

Figure 16. HPST Input Current vs Supply Voltage

Typical Performance Curves - continued
(Reference Data)

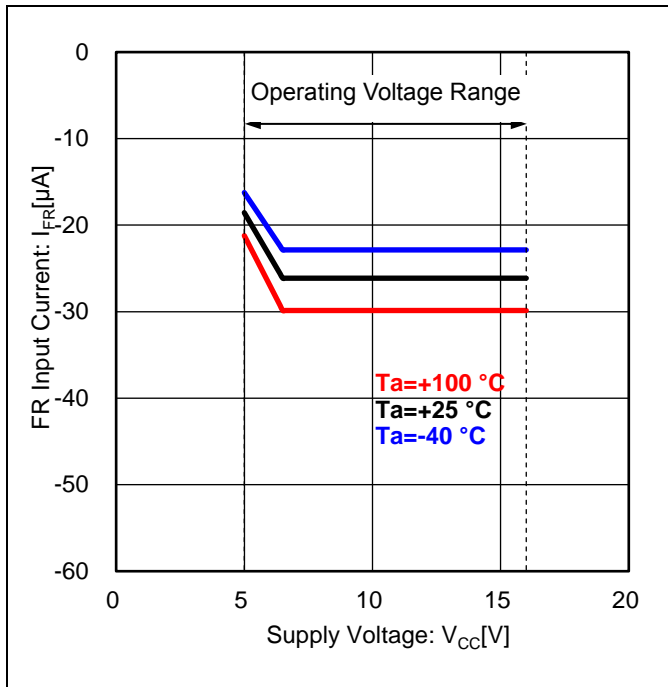

Figure 17. FR Input Current vs Supply Voltage ($V_{FR}=0$ V)

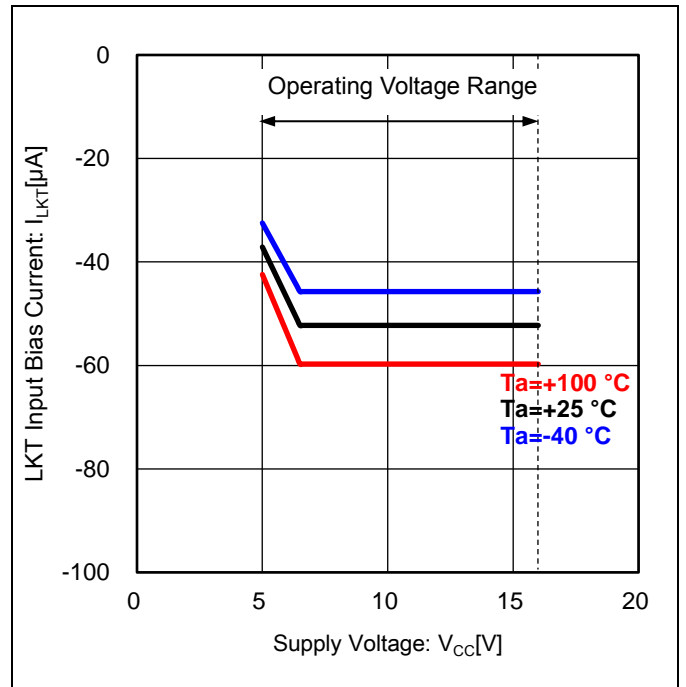

Figure 18. LKT Input Bias Current vs Supply Voltage ($V_{LKT}=0$ V)

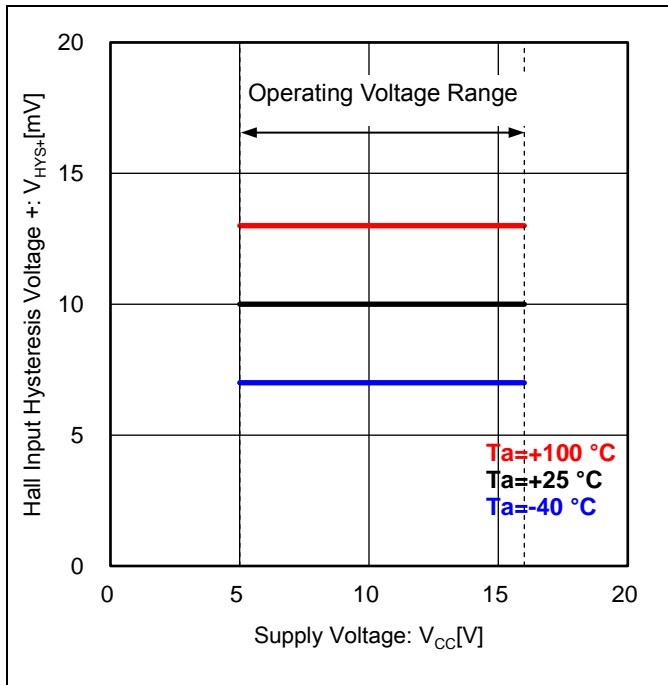

Figure 19. Hall Input Hysteresis Voltage + vs Supply Voltage

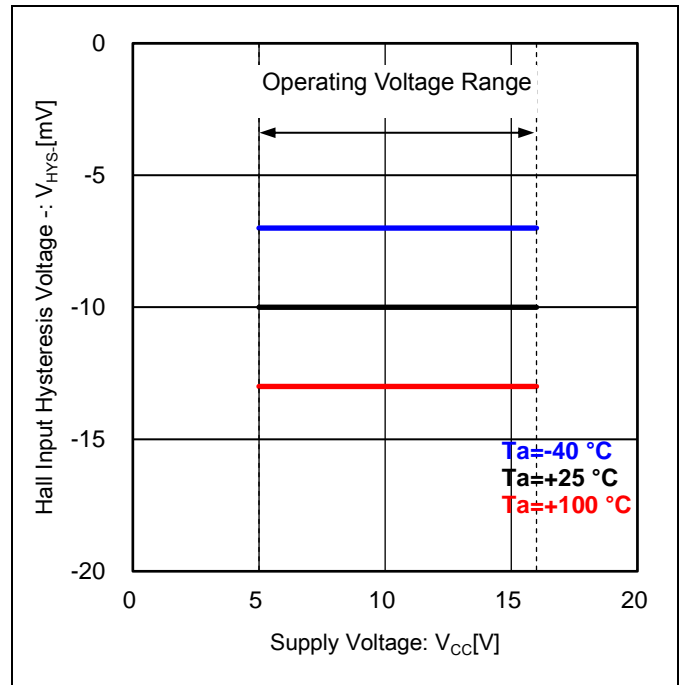

Figure 20. Hall Input Hysteresis Voltage - vs Supply Voltage

Application Examples

1. Variable Speed Control Application Using PWM Duty Converted to DC Voltage.

This is the application example to control rotation speed by the external PWM signal converted to DC voltage.

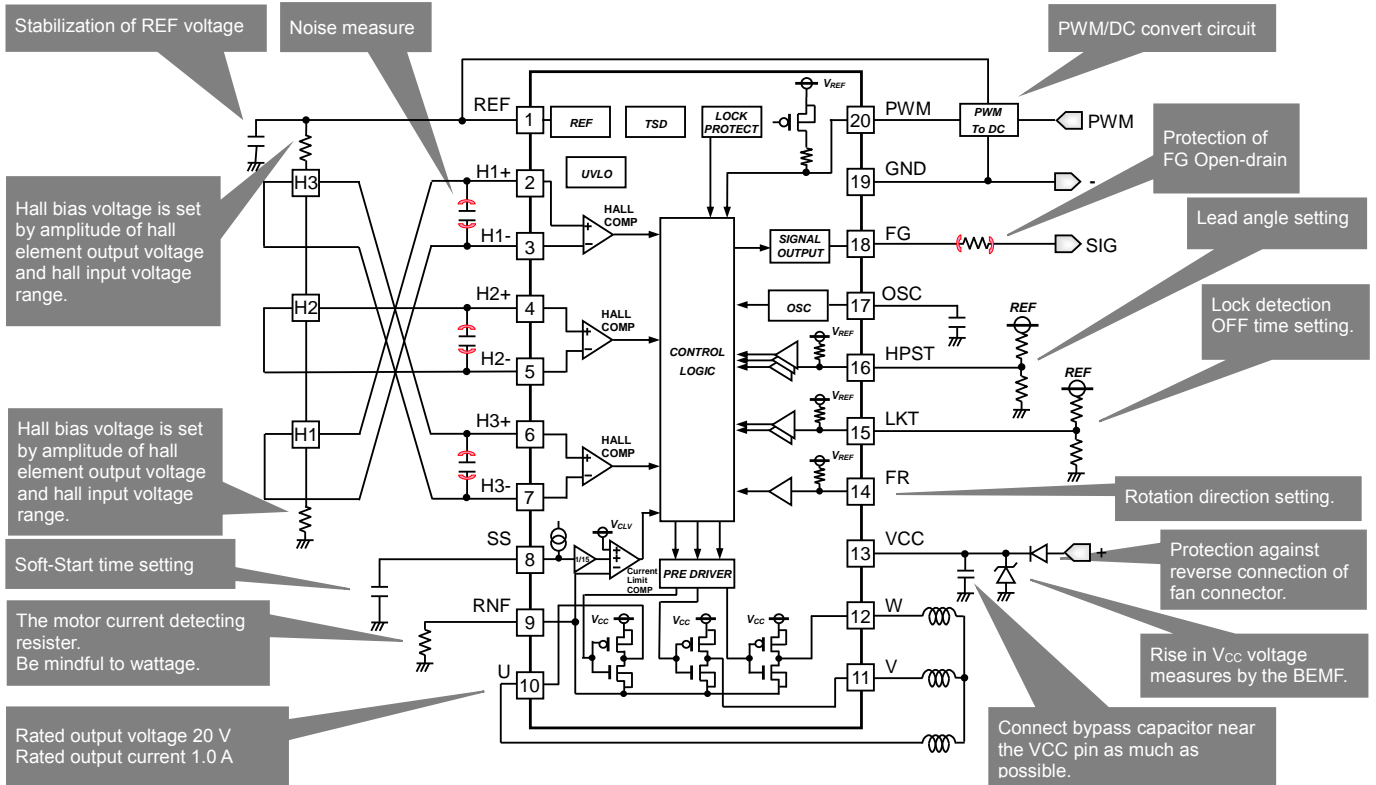

Figure 21. PWM Duty Convert DC Voltage Application

2. Variable Speed Control Application by Input PWM Duty

This is the application example to control rotation speed by the direct input external PWM signal.

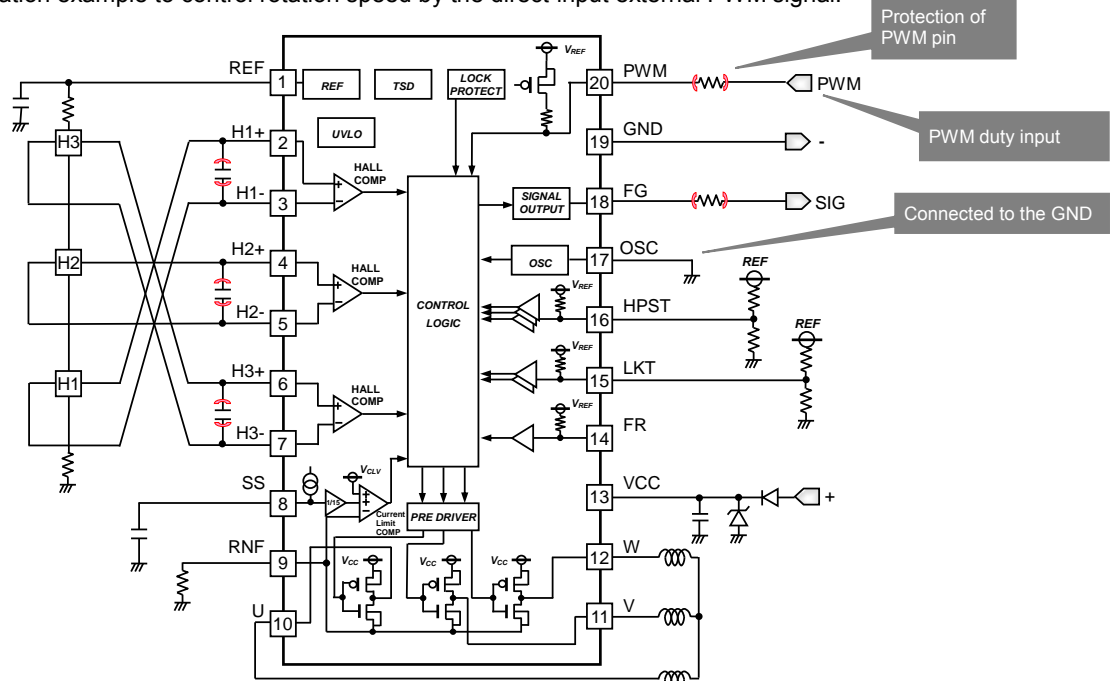

Figure 22. Input PWM Duty Signal Application

Board Design Note

1. IC power (VCC), motor outputs (U, V, W), and motor ground (RNF) lines are made as wide as possible.
2. The IC ground (GND) is common with the application ground except motor ground, and arranged as close as possible to (-) land.
3. The bypass capacitor and the Zener diode are placed as near as possible to the VCC pin.

Description of Function Operations

1. 3 Hall Sine Drive

BD63282EFV detects rotor position by hall element. It is a motor driver IC for sine drive. Using hall signal, it makes the coil current of a three-phase brushless DC motor a sine waveform.

At start-up, it confirms the rotation of the rotor in the normal rotation judgement section for 100 ms(Typ). If normal rotation is not detected, it is judged rotor is stop and it moves to the sine start-up section. In the sine start-up section, it gradually accelerates the rotation speed until the stable rotation speed (The difference between previous FG cycle and current FG cycle is 3.125 %(Typ) or lower.) which depends on input PWM duty. After the rotation speed is stable, it moves to the sine driving section. If detects normal rotation in the normal rotation judgement section, the state moves to the sine driving section. If detects reverse rotation in the normal rotation judgement section, it sets low the output logic of U, V, W and stops the rotation of the rotor. When V_{LKT} is open, after 5 s(Typ), it moves to the normal rotation judgement section again.

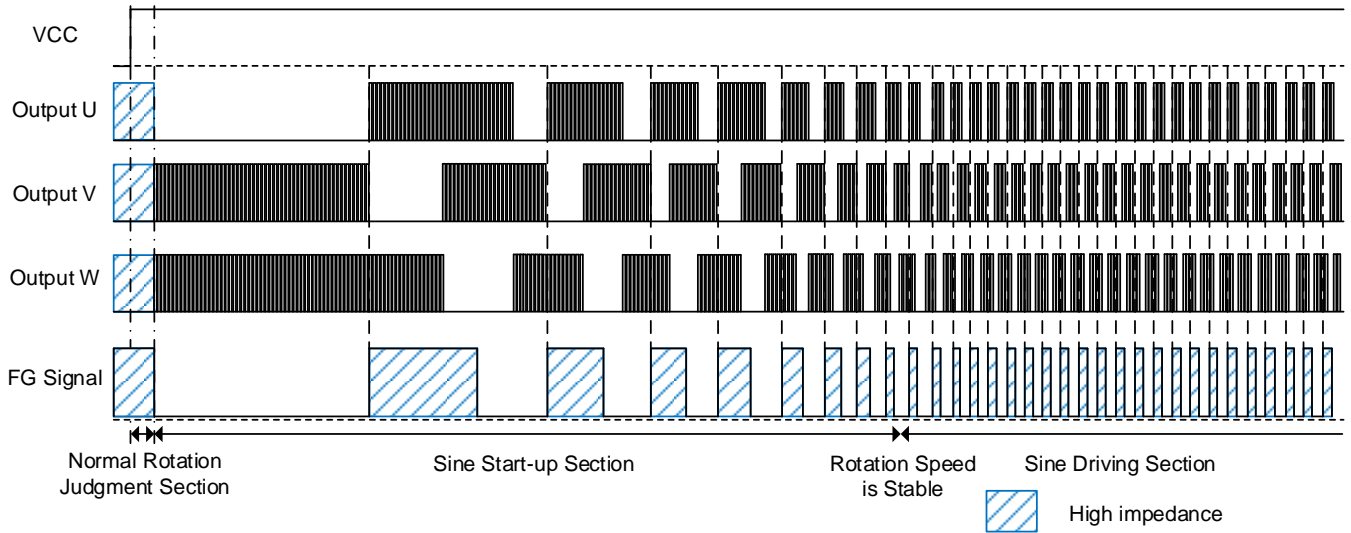

Figure 23. Timing Chart of Forward Rotation Mode Output Signals (U, V, W) and FG Signal (FR = H)

Table 1. Driving Section Description

Driving Section	Function
Normal Rotation Judgement Section	Detect the rotation of the rotor. (100 ms(Typ))
Sine Start-up Section	Gradually accelerate the rotor speed with rotor position detection signal from 3 hall elements until the stable rotor speed (The difference between previous FG cycle and current FG cycle is 3.125%(Typ) or lower)
Sine Driving Section	Motor driving with rotor position detection signal from 1 hall element.

Description of Function Operations – continued

2. Current Limit

BD63282EFV has the current limit function that limits the current flowing through the motor coil. When the current flowing through the motor coil is detects a set current value or more, adjusts output PWM duty. When not using the current limit function, short the RNF pin with GND.

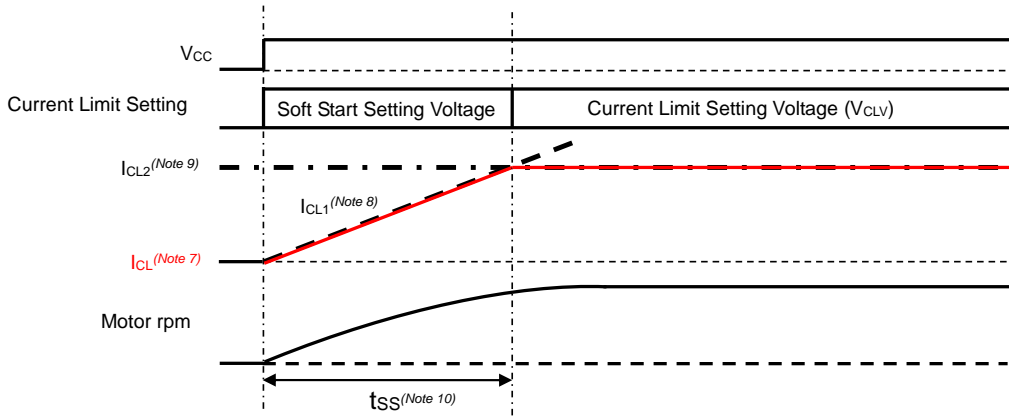

- (Note 7) Current limit setting value.
- (Note 8) Current limit setting determined by 1/15 of the SS pin voltage (V_{SS}).
- (Note 9) Current limit setting determined by the current limit setting voltage inside the IC (V_{CLV}).
- (Note 10) Soft start time.

Figure 24. Timing Chart in Motor Start-up

2.1. Current Limit in Soft Start Setting Voltage Section

In the soft start setting voltage section, current limit setting value is determined by 1/15 (Typ) of the SS pin voltage and the RNF pin voltage. After start-up, the SS pin voltage is gradually increase in time according to the capacity of capacitor connected to the SS pin (Soft start time, t_{SS}) from 0 V (Soft start function). If the SS pin voltage become current limit setting voltage inside the IC (V_{CLV} , 150 mV(Typ)) or more, the state moves to current limit setting voltage section. As shown in Figure 25, if the current detection resistance (R_1) is 0.20 Ω , the SS pin voltage is 0.75 V, the current limit setting value and the power consumption value of the current detection resistance can be obtained from the following formula.

$$V_{CL1} = V_{SS} \times \frac{1}{15} = \frac{0.75}{15} = 50 \text{ [mV]}$$

$$I_{CL1} = \frac{V_{CL1}}{R_1} = \frac{50 \text{ m}}{0.2} = 0.25 \text{ [A]}$$

$$P_{RMAX} = V_{CL1} \times I_{CL1}$$

$$= 50 \text{ m} \times 0.25 = 0.0125 \text{ [W]}$$

- V_{SS} is the SS pin voltage [V]
- V_{CL1} is the 1/15 (Typ) of the SS pin voltage [V]
- R_1 is the current detection resistance [Ω]
- I_{CL1} is the current limit setting value [A]
- P_{RMAX} is the maximum power consumption value of the current detection resistance [W]

As shown in Figure 25, the IC small signal GND line should be separated to the motor large current GND line connected to R_1 .

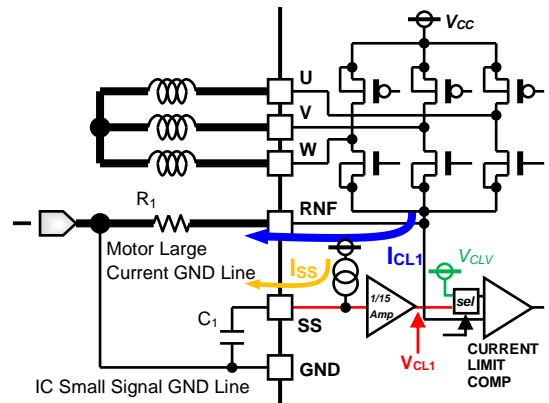

Figure 25. Current Limit Setting (Soft Start Setting Voltage Section)

Description of Function Operations – continued

3. Output signals (U, V, W) and FG Signal Logic in Driving

The timing chart of the output signals (U, V, W), the FG signal and Hall signals in driving is shown in Figure 27. The FG signal is generated from the Hall signal. The relation of the placement of Hall elements and motor coil of each phase is shown in Figure 28.

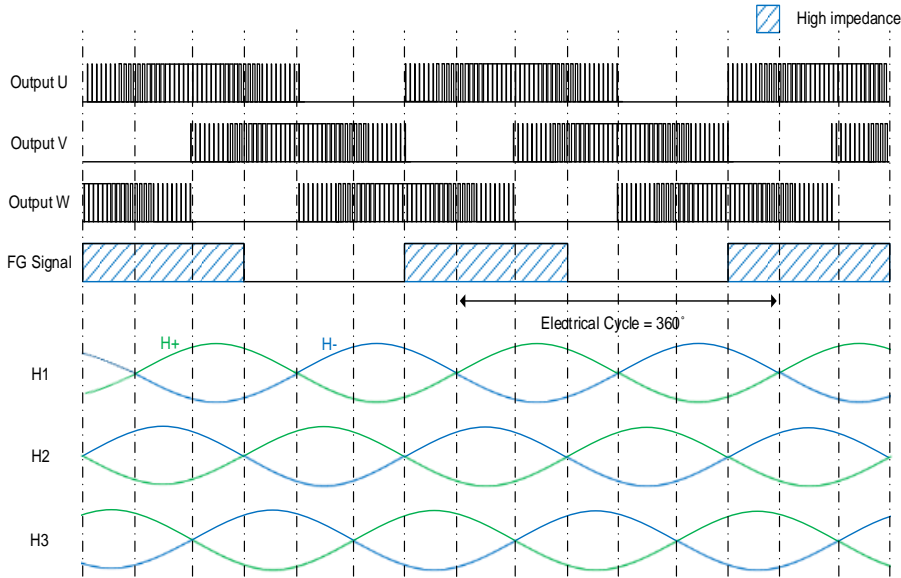

Figure 27. Timing Chart of Forward Rotation Mode Output Signals (U, V, W), FG Signal and Hall Signal (FR = H)

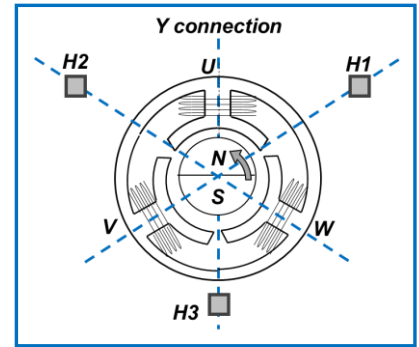

Figure 28. Placement of Hall elements (Reference)

4. Motor Rotation Direction Setting (FR Pin)

The FR pin input voltage sets the rotation direction of the motor. The input voltage range and function is shown as Table 2. When the FR pin is open, it sets the forward rotation mode.

Table 2. FR Mode and Motor Rotation Direction (V_{CC}=12 V)

FR Mode	FR Pin Voltage [V]	Motor Rotation Direction
Forward Rotation Mode	3.8 to V _{REF}	Forward Rotation (U→V→W)
Reverse Rotation Mode	0.0 to 0.8	Reverse Rotation (U→W→V)

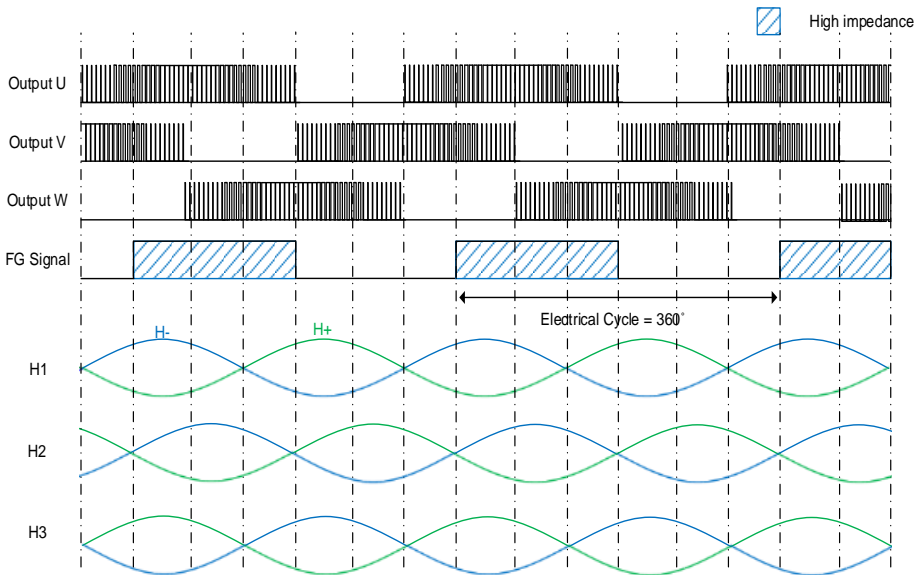

Figure 29. Timing Chart of Reverse Rotation Mode Output Signals (U, V, W), FG Signal and Hall Signal (FR = L)

Description of Function Operations – continued

5. Speed Control

5.1. Speed Control with DC Voltage

The DC voltage input to PWM pin controls the motor rotation speed. As shown in Figure 31, the command PWM duty is generated by comparing the DC voltage input to the PWM pin with the triangular wave generated by the OSC circuit. The command PWM duty is determined by the PWM voltage.

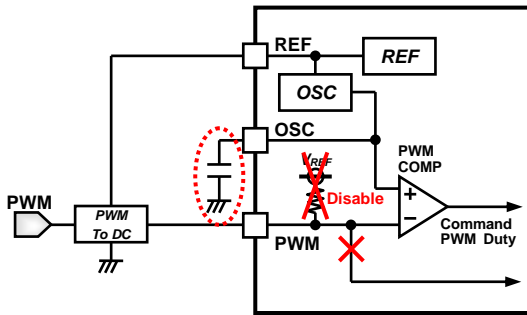

Figure 30. DC Voltage Input Application

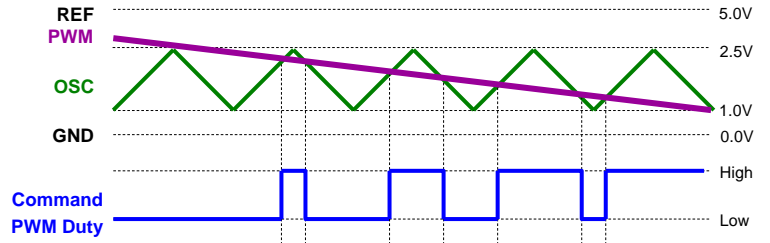

Figure 31. Timing Chart of PWM Duty Generation in DC Voltage Input

The OSC High voltage (2.5 V(Typ)) and the Low voltage (1.0 V(Typ)) are made by resistance division of the reference voltage (REF) and are designed to be resistant to voltage ratio fluctuations. Therefore, by setting the PWM pin input voltage to the REF voltage reference, it is possible to make it an application that is not easily affected even if there is voltage fluctuation of the triangular wave. In this case as well, in applications requiring strict accuracy, decide the value with sufficient margin after consideration.

5.2. OSC Frequency Setting

The capacitor value (C_{OSC}) connected to the OSC pin sets the OSC frequency.

Equation

$$f_{OSC} = \frac{|I_{DOSC} \times I_{COSC}|}{C_{OSC} \times (|I_{DOSC}| + |I_{COSC}|) \times (V_{OSCH} - V_{OSCL})} \text{ [Hz]}$$

f_{OSC} is the OSC frequency [Hz]

C_{OSC} is the OSC capacitor value [F]

I_{DOSC} is the OSC discharge current [A] (Typ +40 μ A)

I_{COSC} is the OSC charge current [A] (Typ -40 μ A)

V_{OSCH} is the OSC high voltage [V] (Typ 2.5 V)

V_{OSCL} is the OSC low voltage [V] (Typ 1.0 V)

(Example) If the OSC capacitor value is 330 pF, the OSC frequency is around 40.4 kHz

$$f_{OSC} = \frac{|(+40 \mu) \times (-40 \mu)|}{330 \text{ p} \times (|+40 \mu| + |-40 \mu|) \times (2.5 - 1.0)} \cong 40.4 \text{ [kHz]}$$

5. Speed Control – continued

5.3. Speed Control with PWM Input

The PWM signal input to the PWM pin controls the motor rotation speed. As shown in Figure 33, the command PWM duty is determined by the PWM signal of the PWM pin. The OSC pin is connected to the GND.

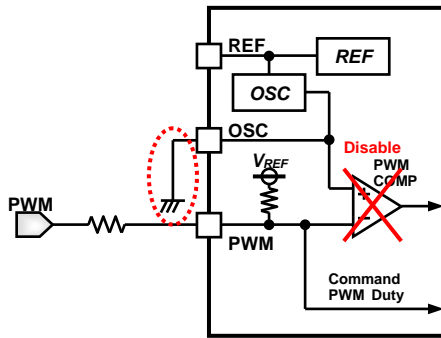

Figure 32. PWM Input Application

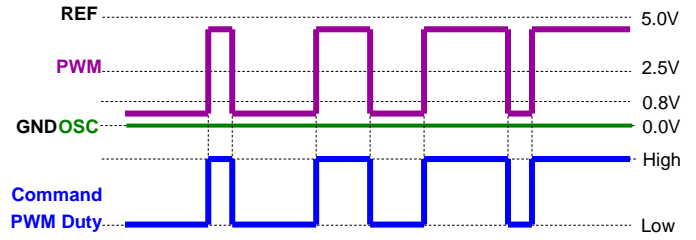

Figure 33. Timing Chart of PWM Duty Generation in PWM Input

5.4. PWM Input Characteristics

When the command PWM duty reaches 5 % (Typ) or more, the IC starts driving and outputs the PWM signal from output pins (U, V, W). Also, when the PWM command duty becomes 1 % (Typ) or less, the IC stops driving and output pins become low. In other areas, the output PWM duty is proportional to the command PWM duty.

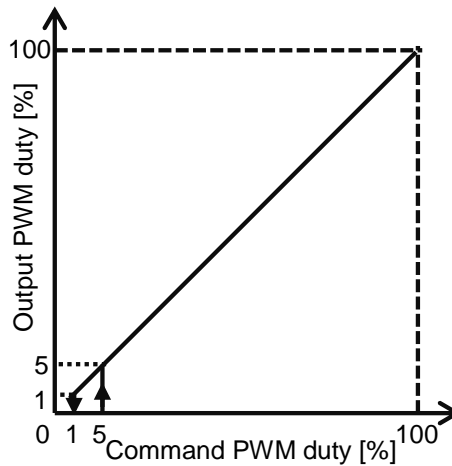

Figure 34. Output PWM Duty vs Command PWM Duty

Description of Function Operating - continued

6. Under Voltage Lock Out Protection Function (UVLO)

The under voltage lock out protection function is a protection function to prevent unexpected operation such as large current flow by turning output pins to OFF state in an extremely low supply voltage range deviating from normal operation. When the supply voltage is 3.9 V (Typ) or less, the under voltage lock out circuit operates (UVLO ON) and output pins are turned OFF. It returns to normal operation (UVLO OFF) when the supply voltage is 4.2 V (Typ) or more.

7. Lock Protection Function (Automatic Recovery)

When a motor is locked, the lock protection function (automatic recovery) is becoming output pins to low state for a certain time (Lock detection OFF time, t_{OFF}) so as not to keep flowing current through the coil, and then automatically recovers. The position detection signals of each hall elements are toggling during the motor rotation. However, when the motor is locked, the position detection signal of each hall are not toggling. This is used to judge the motor lock state. In the BD63282EFV, there are different lock judgement condition in sine start-up section and sine driving section. The lock detection OFF time in motor lock state can be selected by the LKT input voltage.

7.1. Lock Judgement Condition in Sine Start-up Section

After start-up normal rotation judgement section, when the switching of position detection signal from hall element is not detected until 1.0 s(Typ), judged motor is locked and the lock protection function is started.

7.2. Lock Judgement Condition in Sine Driving Section

At the sine driving section, when the switching of the position detection signal of Hall element (H1) is not detected in 400ms(Typ), judged motor is locked and the lock protection function is started.

7.3. Setting of the Lock Detection OFF Time (t_{OFF}) (LKT pin)

The LKT pin input voltage sets the lock detection OFF time (t_{OFF}). The input voltage range and function is shown as table 3.

Table 3. Lock Detection OFF Time (t_{OFF}) and LKT Input Voltage ($V_{CC}=12\text{ V}$)

Lock Detection Mode	LKT Pin Input Voltage [V]	Lock Detection OFF Time
t_{OFF1} Mode	2.2 to V_{REF}	5 s (Typ)
t_{OFF2} Mode	1.2 to 1.8	10 s (Typ)
t_{OFF3} Mode	0.0 to 0.8	2 s (Typ)

8. High Speed Rotation Protection Function and Low Speed Rotation Protection Function

The high speed rotation protection function and the low speed rotation protection function set output pins to low state for a certain time (t_{OFF}) so that the motor speed does not become uncontrollable by becoming faster or slower than expected, and then automatically recovers. The speed protection function and the FG signal frequency condition is shown as Table 4.

Table 4. Speed Protection Function and FG Signal Frequency Condition

Speed Protection Function	FG Signal Frequency Condition
High Speed Rotation Protection	1666.7 Hz (Typ) or more
Low Speed Rotation Protection	2.5 Hz (Typ) or less

9. Lead Angle Control Setting (HPST pin)

The HPST pin input voltage sets the lead angle control setting. The input voltage range and lead angle mode is shown as Table 5. The auto lead angle control function has been enabled when the auto lead angle mode is set. The fixed lead angle control function has been enabled when the fixed lead angle mode is set. In the Fixed lead angle control mode, the phase of the output voltage is controlled, to advance the phase of the current flowing through the motor coil by the setting angle from the phase of input hall signal.

Table 5. Lead angle mode and HPST input voltage

Lead Angle Mode	HPST Pin Voltage [V]
Auto Lead Angle Control Mode	3.85 to V_{REF}
Fixed Lead Angle Control Mode (25°)	2.60 to 3.65
Fixed Lead Angle Control Mode (10°)	1.35 to 2.40
Fixed Lead Angle Control Mode (0°)	0.00 to 1.15

Thermal Resistance Model

Heat generated by consumed power of IC is radiated from the mold resin or lead frame of package. The parameter which indicates this heat dissipation capability (hardness of heat release) is called thermal resistance. Thermal resistance from the chip junction to the ambient temperature is represented in θ_{JA} [$^{\circ}\text{C}/\text{W}$], and thermal characterization parameter from junction to the top center of the outside surface of the component package is represented in Ψ_{JT} [$^{\circ}\text{C}/\text{W}$]. Thermal resistance is divided into the package part and the substrate part. Thermal resistance in the package part depends on the composition materials such as the mold resins and the lead frames. On the other hand, thermal resistance in the substrate part depends on the substrate heat dissipation capability of the material, the size, and the copper foil area etc. Therefore, thermal resistance can be decreased by the heat radiation measures like installing a heat sink etc. in the mounting substrate.

The thermal resistance model is shown in Figure 35 and equation is shown below.

Equation

$$\theta_{JA} = \frac{Tj - Ta}{P} \text{ [}^{\circ}\text{C/W]}]$$

$$\Psi_{JT} = \frac{Tj - Tt}{P} \text{ [}^{\circ}\text{C/W]}]$$

Where:

θ_{JA} is the thermal resistance from junction to ambient temperature [$^{\circ}\text{C}/\text{W}$]

Ψ_{JT} is the thermal characterization parameter from junction to the top center of the outside surface of the component package [$^{\circ}\text{C}/\text{W}$]

Tj is the junction temperature [$^{\circ}\text{C}$]

Ta is the ambient temperature [$^{\circ}\text{C}$]

Tt is the package outside surface (top center) temperature [$^{\circ}\text{C}$]

P is the power consumption [W]

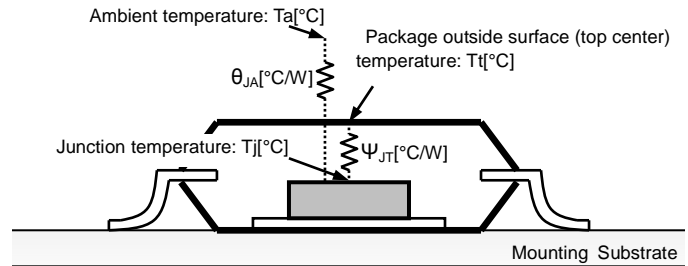
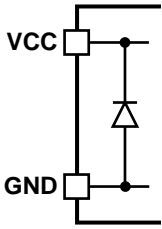

Figure 35. Thermal Resistance Model of Surface Mount

Even if it uses the same package, θ_{JA} and Ψ_{JT} are changed depending on the chip size, power consumption and the measurement environments of the ambient temperature, the mounting condition and the wind velocity, etc.

I/O Equivalence Circuits (Resistance Values are Typical)

1. VCC, GND pins



2. PWM pin

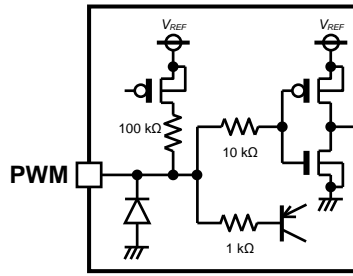

3. HPST pin

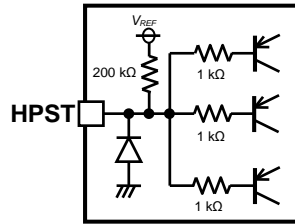

4. H1+, H2+, H3+, H1-, H2-, H3- pins

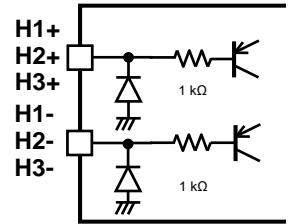

5. REF pin

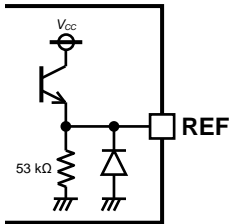

6. OSC pin

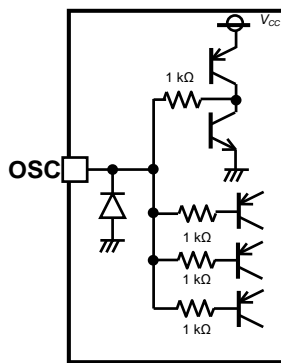

7. SS pin

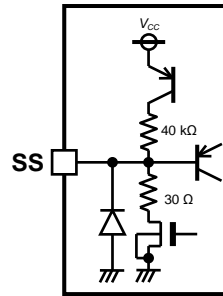

8. FG pin

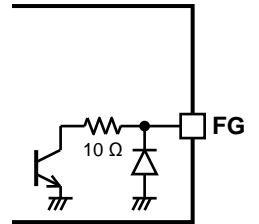

9. LKT pin

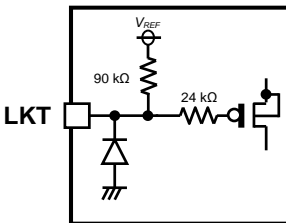

10. U, V, W, RNF pins

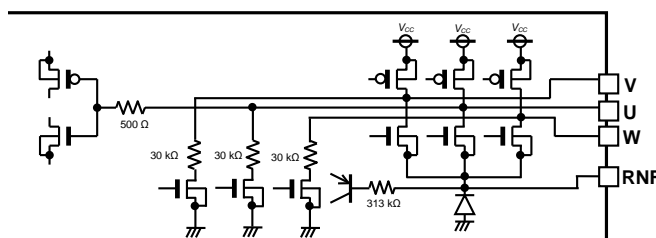

11. FR pin

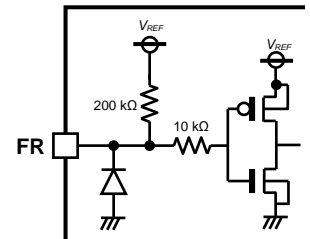

Note for Content

Timing charts might be omitted or simplified to explain functional operation.

Operational Notes

1. Reverse Connection of Power Supply

Connecting the power supply in reverse polarity can damage the IC. Take precautions against reverse polarity when connecting the power supply, such as mounting an external diode between the power supply and the IC's power supply pins.

2. Power Supply Lines

Design the PCB layout pattern to provide low impedance supply lines. Furthermore, connect a capacitor to ground at all power supply pins. Consider the effect of temperature and aging on the capacitance value when using electrolytic capacitors.

3. Ground Voltage

Ensure that no pins are at a voltage below that of the ground pin at any time, even during transient condition. However, pins that drive inductive loads (e.g. motor driver outputs, DC-DC converter outputs) may inevitably go below ground due to back EMF or electromotive force. In such cases, the user should make sure that such voltages going below ground will not cause the IC and the system to malfunction by examining carefully all relevant factors and conditions such as motor characteristics, supply voltage, operating frequency and PCB wiring to name a few.

4. Ground Wiring Pattern

When using both small-signal and large-current ground traces, the two ground traces should be routed separately but connected to a single ground at the reference point of the application board to avoid fluctuations in the small-signal ground caused by large currents. Also ensure that the ground traces of external components do not cause variations on the ground voltage. The ground lines must be as short and thick as possible to reduce line impedance.

5. Recommended Operating Conditions

The function and operation of the IC are guaranteed within the range specified by the recommended operating conditions. The characteristic values are guaranteed only under the conditions of each item specified by the electrical characteristics.

6. Inrush Current

When power is first supplied to the IC, it is possible that the internal logic may be unstable and inrush current may flow instantaneously due to the internal powering sequence and delays, especially if the IC has more than one power supply. Therefore, give special consideration to power coupling capacitance, power wiring, width of ground wiring, and routing of connections.

7. Testing on Application Boards

When testing the IC on an application board, connecting a capacitor directly to a low-impedance output pin may subject the IC to stress. Always discharge capacitors completely after each process or step. The IC's power supply should always be turned off completely before connecting or removing it from the test setup during the inspection process. To prevent damage from static discharge, ground the IC during assembly and use similar precautions during transport and storage.

8. Inter-pin Short and Mounting Errors

Ensure that the direction and position are correct when mounting the IC on the PCB. Incorrect mounting may result in damaging the IC. Avoid nearby pins being shorted to each other especially to ground, power supply and output pin. Inter-pin shorts could be due to many reasons such as metal particles, water droplets (in very humid environment) and unintentional solder bridge deposited in between pins during assembly to name a few.

9. Unused Input Pins

Input pins of an IC are often connected to the gate of a MOS transistor. The gate has extremely high impedance and extremely low capacitance. If left unconnected, the electric field from the outside can easily charge it. The small charge acquired in this way is enough to produce a significant effect on the conduction through the transistor and cause unexpected operation of the IC. So unless otherwise specified, unused input pins should be connected to the power supply or ground line.

Operational Notes – continued

10. Regarding the Input Pin of the IC

This monolithic IC contains P+ isolation and P substrate layers between adjacent elements in order to keep them isolated. P-N junctions are formed at the intersection of the P layers with the N layers of other elements, creating a parasitic diode or transistor. For example (refer to figure below):

When $GND > Pin A$ and $GND > Pin B$, the P-N junction operates as a parasitic diode.

When $GND > Pin B$, the P-N junction operates as a parasitic transistor.

Parasitic diodes inevitably occur in the structure of the IC. The operation of parasitic diodes can result in mutual interference among circuits, operational faults, or physical damage. Therefore, conditions that cause these diodes to operate, such as applying a voltage lower than the GND voltage to an input pin (and thus to the P substrate) should be avoided.

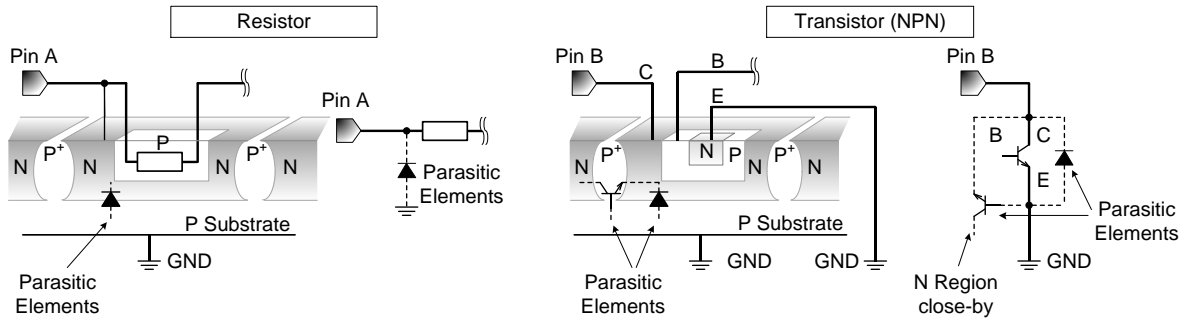

Figure 36. Example of Monolithic IC Structure

11. Ceramic Capacitor

When using a ceramic capacitor, determine a capacitance value considering the change of capacitance with temperature and the decrease in nominal capacitance due to DC bias and others.

12. Thermal Shutdown Circuit (TSD)

This IC has a built-in thermal shutdown circuit that prevents heat damage to the IC. Normal operation should always be within the IC's maximum junction temperature rating. If however the rating is exceeded for a continued period, the junction temperature (T_j) will rise which will activate the TSD circuit that will turn OFF power output pins. When the T_j falls below the TSD threshold, the circuits are automatically restored to normal operation.

Note that the TSD circuit operates in a situation that exceeds the absolute maximum ratings and therefore, under no circumstances, should the TSD circuit be used in a set design or for any purpose other than protecting the IC from heat damage.

Ordering Information

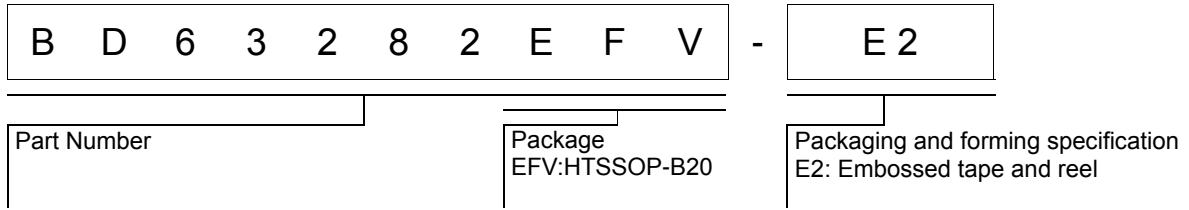

Marking Diagram

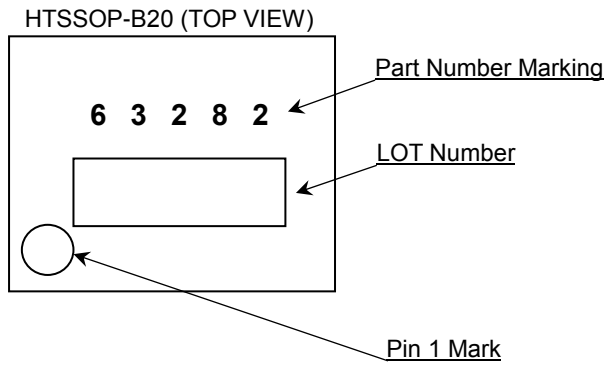

Physical Dimension and Packing Information

Package Name	HTSSOP-B20
--------------	------------

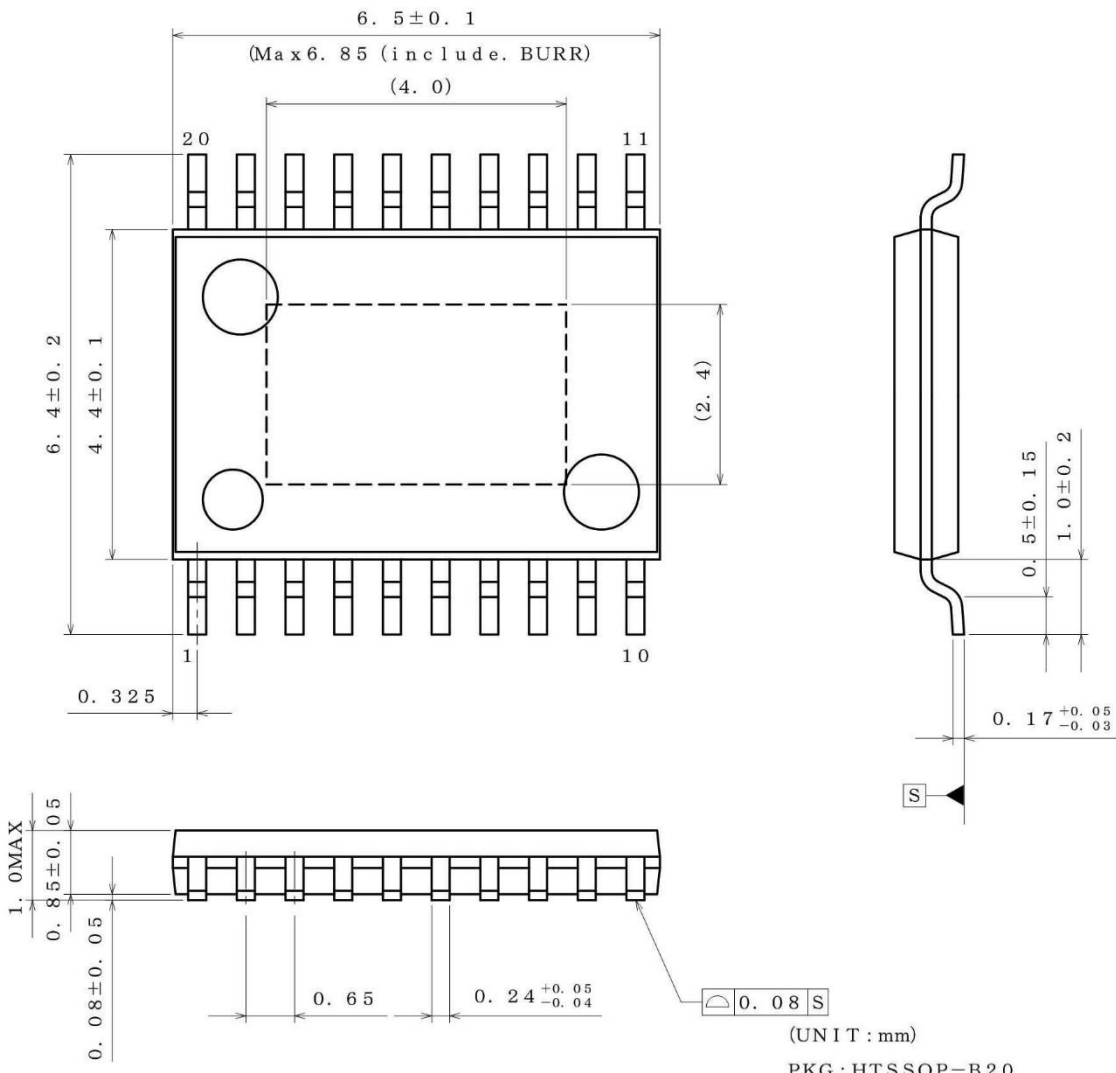

PKG : HTSSOP-B20
Drawing No. EX192-5002

<Tape and Reel information>

Tape	Embossed carrier tape (with dry pack)
Quantity	2500pcs
Direction of feed	E2 (The direction is the 1pin of product is at the upper left when you hold reel on the left hand and you pull out the tape on the right hand)

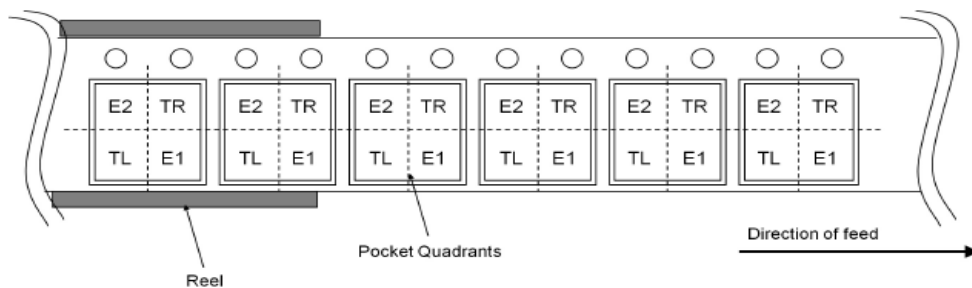

Revision History

Date	Revision	Changes
08.Feb.2019	001	New Release

Notice

Precaution on using ROHM Products

- Our Products are designed and manufactured for application in ordinary electronic equipment (such as AV equipment, OA equipment, telecommunication equipment, home electronic appliances, amusement equipment, etc.). If you intend to use our Products in devices requiring extremely high reliability (such as medical equipment ^(Note 1), transport equipment, traffic equipment, aircraft/spacecraft, nuclear power controllers, fuel controllers, car equipment including car accessories, safety devices, etc.) and whose malfunction or failure may cause loss of human life, bodily injury or serious damage to property ("Specific Applications"), please consult with the ROHM sales representative in advance. Unless otherwise agreed in writing by ROHM in advance, ROHM shall not be in any way responsible or liable for any damages, expenses or losses incurred by you or third parties arising from the use of any ROHM's Products for Specific Applications.

(Note1) Medical Equipment Classification of the Specific Applications

JAPAN	USA	EU	CHINA
CLASS III	CLASS III	CLASS II b	CLASS III
CLASS IV		CLASS III	

- ROHM designs and manufactures its Products subject to strict quality control system. However, semiconductor products can fail or malfunction at a certain rate. Please be sure to implement, at your own responsibilities, adequate safety measures including but not limited to fail-safe design against the physical injury, damage to any property, which a failure or malfunction of our Products may cause. The following are examples of safety measures:
 - Installation of protection circuits or other protective devices to improve system safety
 - Installation of redundant circuits to reduce the impact of single or multiple circuit failure
- Our Products are designed and manufactured for use under standard conditions and not under any special or extraordinary environments or conditions, as exemplified below. Accordingly, ROHM shall not be in any way responsible or liable for any damages, expenses or losses arising from the use of any ROHM's Products under any special or extraordinary environments or conditions. If you intend to use our Products under any special or extraordinary environments or conditions (as exemplified below), your independent verification and confirmation of product performance, reliability, etc. prior to use, must be necessary:
 - Use of our Products in any types of liquid, including water, oils, chemicals, and organic solvents
 - Use of our Products outdoors or in places where the Products are exposed to direct sunlight or dust
 - Use of our Products in places where the Products are exposed to sea wind or corrosive gases, including Cl₂, H₂S, NH₃, SO₂, and NO₂
 - Use of our Products in places where the Products are exposed to static electricity or electromagnetic waves
 - Use of our Products in proximity to heat-producing components, plastic cords, or other flammable items
 - Sealing or coating our Products with resin or other coating materials
 - Use of our Products without cleaning residue of flux (Exclude cases where no-clean type fluxes is used. However, recommend sufficiently about the residue.) ; or Washing our Products by using water or water-soluble cleaning agents for cleaning residue after soldering
 - Use of the Products in places subject to dew condensation
- The Products are not subject to radiation-proof design.
- Please verify and confirm characteristics of the final or mounted products in using the Products.
- In particular, if a transient load (a large amount of load applied in a short period of time, such as pulse, is applied, confirmation of performance characteristics after on-board mounting is strongly recommended. Avoid applying power exceeding normal rated power; exceeding the power rating under steady-state loading condition may negatively affect product performance and reliability.
- De-rate Power Dissipation depending on ambient temperature. When used in sealed area, confirm that it is the use in the range that does not exceed the maximum junction temperature.
- Confirm that operation temperature is within the specified range described in the product specification.
- ROHM shall not be in any way responsible or liable for failure induced under deviant condition from what is defined in this document.

Precaution for Mounting / Circuit board design

- When a highly active halogenous (chlorine, bromine, etc.) flux is used, the residue of flux may negatively affect product performance and reliability.
- In principle, the reflow soldering method must be used on a surface-mount products, the flow soldering method must be used on a through hole mount products. If the flow soldering method is preferred on a surface-mount products, please consult with the ROHM representative in advance.

For details, please refer to ROHM Mounting specification

Precautions Regarding Application Examples and External Circuits

1. If change is made to the constant of an external circuit, please allow a sufficient margin considering variations of the characteristics of the Products and external components, including transient characteristics, as well as static characteristics.
2. You agree that application notes, reference designs, and associated data and information contained in this document are presented only as guidance for Products use. Therefore, in case you use such information, you are solely responsible for it and you must exercise your own independent verification and judgment in the use of such information contained in this document. ROHM shall not be in any way responsible or liable for any damages, expenses or losses incurred by you or third parties arising from the use of such information.

Precaution for Electrostatic

This Product is electrostatic sensitive product, which may be damaged due to electrostatic discharge. Please take proper caution in your manufacturing process and storage so that voltage exceeding the Products maximum rating will not be applied to Products. Please take special care under dry condition (e.g. Grounding of human body / equipment / solder iron, isolation from charged objects, setting of Ionizer, friction prevention and temperature / humidity control).

Precaution for Storage / Transportation

1. Product performance and soldered connections may deteriorate if the Products are stored in the places where:
 - [a] the Products are exposed to sea winds or corrosive gases, including Cl₂, H₂S, NH₃, SO₂, and NO₂
 - [b] the temperature or humidity exceeds those recommended by ROHM
 - [c] the Products are exposed to direct sunshine or condensation
 - [d] the Products are exposed to high Electrostatic
2. Even under ROHM recommended storage condition, solderability of products out of recommended storage time period may be degraded. It is strongly recommended to confirm solderability before using Products of which storage time is exceeding the recommended storage time period.
3. Store / transport cartons in the correct direction, which is indicated on a carton with a symbol. Otherwise bent leads may occur due to excessive stress applied when dropping of a carton.
4. Use Products within the specified time after opening a humidity barrier bag. Baking is required before using Products of which storage time is exceeding the recommended storage time period.

Precaution for Product Label

A two-dimensional barcode printed on ROHM Products label is for ROHM's internal use only.

Precaution for Disposition

When disposing Products please dispose them properly using an authorized industry waste company.

Precaution for Foreign Exchange and Foreign Trade act

Since concerned goods might be fallen under listed items of export control prescribed by Foreign exchange and Foreign trade act, please consult with ROHM in case of export.

Precaution Regarding Intellectual Property Rights

1. All information and data including but not limited to application example contained in this document is for reference only. ROHM does not warrant that foregoing information or data will not infringe any intellectual property rights or any other rights of any third party regarding such information or data.
2. ROHM shall not have any obligations where the claims, actions or demands arising from the combination of the Products with other articles such as components, circuits, systems or external equipment (including software).
3. No license, expressly or implied, is granted hereby under any intellectual property rights or other rights of ROHM or any third parties with respect to the Products or the information contained in this document. Provided, however, that ROHM will not assert its intellectual property rights or other rights against you or your customers to the extent necessary to manufacture or sell products containing the Products, subject to the terms and conditions herein.

Other Precaution



1. This document may not be reprinted or reproduced, in whole or in part, without prior written consent of ROHM.
2. The Products may not be disassembled, converted, modified, reproduced or otherwise changed without prior written consent of ROHM.
3. In no event shall you use in any way whatsoever the Products and the related technical information contained in the Products or this document for any military purposes, including but not limited to, the development of mass-destruction weapons.
4. The proper names of companies or products described in this document are trademarks or registered trademarks of ROHM, its affiliated companies or third parties.

General Precaution





1. Before you use our Products, you are requested to carefully read this document and fully understand its contents. ROHM shall not be in any way responsible or liable for failure, malfunction or accident arising from the use of any ROHM's Products against warning, caution or note contained in this document.
2. All information contained in this document is current as of the issuing date and subject to change without any prior notice. Before purchasing or using ROHM's Products, please confirm the latest information with a ROHM sales representative.
3. The information contained in this document is provided on an "as is" basis and ROHM does not warrant that all information contained in this document is accurate and/or error-free. ROHM shall not be in any way responsible or liable for any damages, expenses or losses incurred by you or third parties resulting from inaccuracy or errors of or concerning such information.

Looking for pricing, stock, or lifecycle information?

Click below to explore more details on WIN SOURCE:

-  [View BD63282EFV-E2 on WIN SOURCE](#)
-  [Rohm Semiconductor](#) Information

Optimize Your Supply Chain with WIN SOURCE Solutions

-  Global Sourcing Solution
-  Obsolete Management
-  Cost Control Management
-  Shortage Management
-  Alternative Solution
-  Excess Inventory Management