



**THE DATASHEET OF  
AD9628-125EBZ**



## Evaluating the AD9650/AD9268/AD9258/AD9251/AD9231/AD9204/ AD9269/AD6659 Analog-to-Digital Converters

### FEATURES

Full featured evaluation board for the AD9650/AD9268/  
AD9258/AD9251/AD9231/AD9204/AD9269/AD6659  
SPI interface for setup and control  
External, on-board oscillator, or AD9517 clocking options  
Balun/transformer or amplifier input drive options  
LDO regulator or switching power supply options  
VisualAnalog® and SPI controller software interfaces

### EQUIPMENT NEEDED

Analog signal source and antialiasing filter  
Sample clock source (if not using the on-board oscillator)  
2 switching power supplies (6.0 V, 2.5 A),  
CUI EPS060250UH-PHP-SZ, provided  
PC running Windows® 98 (2nd ed.), Windows 2000,  
Windows ME, or Windows XP  
USB 2.0 port, recommended (USB 1.1 compatible)  
AD9650, AD9268, AD9258, AD9251, AD9231, AD9204, AD9269,  
or AD6659 board  
HSC-ADC-EVALCZ FPGA-based data capture kit

### SOFTWARE NEEDED

VisualAnalog  
SPI controller

### DOCUMENTS NEEDED

[AD9650, AD9268, AD9258, AD9251, AD9231, AD9204, AD9269, or AD6659 data sheet](#)  
[HSC-ADC-EVALCZ data sheet](#)  
[AN-905 Application Note, VisualAnalog Converter Evaluation Tool Version 1.0 User Manual](#)  
[AN-878 Application Note, High Speed ADC SPI Control Software](#)  
[AN-877 Application Note, Interfacing to High Speed ADCs via SPI](#)  
[AN-835 Application Note, Understanding ADC Testing and Evaluation](#)

### GENERAL DESCRIPTION

This document describes the AD9650, AD9268, AD9258, AD9251, AD9231, AD9204, AD9269, and AD6659 evaluation board, which provides all of the support circuitry required to operate these parts in their various modes and configurations. The application software used to interface with the devices is also described.

The AD9650, AD9268, AD9258, AD9251, AD9231, AD9204, AD9269, and AD6659 data sheets provide additional information and should be consulted when using the evaluation board. All documents and software tools are available at [www.analog.com/fifo](http://www.analog.com/fifo). For additional information or questions, send an email to [highspeed.converters@analog.com](mailto:highspeed.converters@analog.com).

### TYPICAL MEASUREMENT SETUP

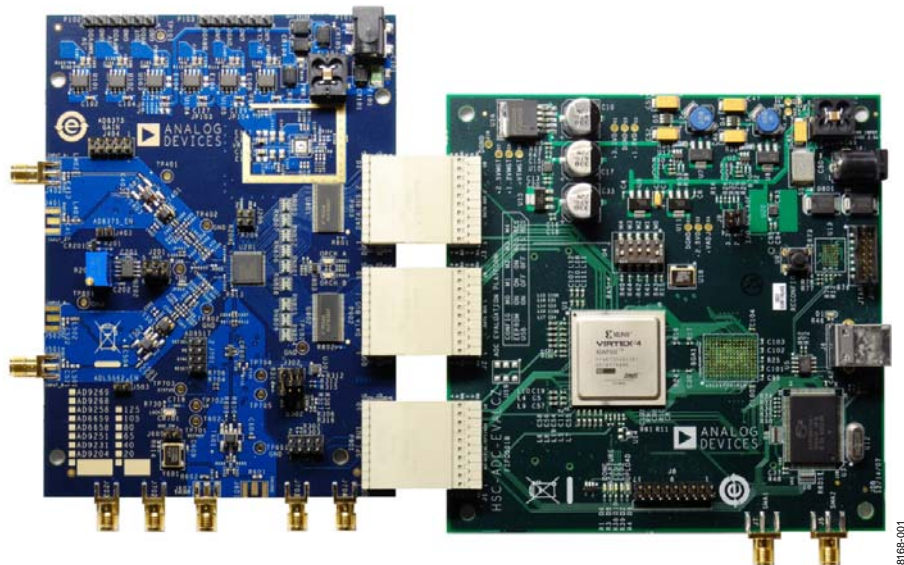

Figure 1. AD9268 and AD9269 Family Evaluation Board and HSC-ADC-EVALCZ Data Capture Board

**TABLE OF CONTENTS**

Features .....	1	Input Signals.....	3
Equipment Needed.....	1	Output Signals .....	3
Software Needed.....	1	Default Operation and Jumper Selection Settings.....	5
Documents Needed.....	1	Evaluation Board Software Quick Start Procedures.....	8
General Description .....	1	Configuring the Board .....	8
Typical Measurement Setup .....	1	Using the Software for Testing.....	8
Revision History .....	2	Evaluation Board Schematics and Artwork.....	12
Evaluation Board Hardware.....	3	Ordering Information.....	27
Power Supplies .....	3	Bill of Materials.....	27

**REVISION HISTORY**

**9/10—Rev. 0 to Rev. A**

Changes to Title, Features Section, Documents Needed Section, and General Description Section .....	1
Changes to Evaluation Board Hardware Section .....	3
Added Table 1; Renumbered Sequentially .....	3
Added Figure 3; Renumbered Sequentially .....	5
Changes to Default Operation and Jumper Selection Settings Section.....	5
Added AD9650 Family Section, AD9268 Family Section, and AD9269 Family Section .....	5
Changes to VREF Section, Clock Circuitry for the AD9269 Family Section, and Clock Circuitry for the AD9650 and the AD9268 Family Section .....	6
Added Table 2.....	6
Changes to Evaluation Board Software Quick Start Procedures Section and Configuring the Board Section .....	8
Added Table 3; Renumbered Sequentially .....	27

**11/09—Revision 0: Initial Version**

## EVALUATION BOARD HARDWARE

The evaluation board provides all of the support circuitry required to operate these parts in their various modes and configurations. Figure 2 shows the typical bench characterization setup used to evaluate the ac performance. It is critical that the signal sources used for the analog input and clock have very low phase noise (<1 ps rms jitter) to realize the optimum performance of the signal chain. Proper filtering of the analog input signal to remove harmonics and lower the integrated or broadband noise at the input is necessary to achieve the specified noise performance.

The evaluation board covers multiple families of ADCs and is populated slightly differently between the families. Table 1 shows the three main families and the ADCs that fall within each family. When a reference is made to the [AD9269](#), for example, this applies to all the ADCs within that family, that is, the [AD9251](#), the [AD9231](#), and the [AD9204](#), the [AD9269](#), and the [AD6659](#).

**Table 1.**

Family Name	ADCs within Each Family
<a href="#">AD9650</a>	AD9650
<a href="#">AD9268</a>	AD9268, <a href="#">AD9258</a>
AD9269	AD9251, AD9231, AD9204, AD9269, AD6659

See the Evaluation Board Software Quick Start Procedures section to get started, and see Figure 17 to Figure 31 for the complete schematics and layout diagrams. These diagrams demonstrate the routing and grounding techniques that should be applied at the system level when designing application boards using these converters.

### POWER SUPPLIES

This evaluation board comes with a wall-mountable switching power supply that provides a 6 V, 2 A maximum output. Connect the supply to the rated 100 V ac to the 240 V ac wall outlet at 47 Hz to 63 Hz. The output from the supply is provided through a 2.1 mm inner diameter jack that connects to the printed circuit board (PCB) at P101. The 6 V supply is fused and conditioned on the PCB before connecting to the low dropout linear regulators (default configuration) that supply the proper bias to each of the various sections on the board.

The evaluation board can be powered in a nondefault condition using external bench power supplies. To do this, the E101, E102, E114, E103, E105, and E107 ferrite beads can be removed to disconnect the outputs from the on-board LDOs. This enables the user to bias each section of the board individually. Use P102 and P103 to connect a different supply for each section. A 1.8 V supply is needed with a 1 A current capability for DUT\_AVDD and

DRVDD; however, it is recommended that separate supplies be used for both analog and digital domains. An additional supply is also required to supply 1.8 V for digital support circuitry on the board, DVDD. This should also have a 1 A current capability and can be combined with DRVDD with little or no degradation in performance. To operate the evaluation board using the SPI and alternate clock options, a separate 3.3 V analog supply is needed in addition to the other supplies. This 3.3 V supply, or 3V\_CLK, should have a 1 A current capability.

Two additional supplies, 5V\_AMPVDD and 3V\_AMPVDD, are used to bias the optional input path amplifiers and optional VREF buffer. If used, these supplies should each have 1 A current capability.

A second optional power supply configuration allows replacing the LDOs that supply the AVDD and DRVDD rails of the ADC with the [ADP2114](#) step-down dc-to-dc regulator. Using this switching controller in place of the LDO regulators to power the AVDD and DRVDD supplies of the ADC allows customers to evaluate the performance of the ADC when powered by a more efficient regulator.

### INPUT SIGNALS

When connecting the clock and analog source, use clean signal generators with low phase noise, such as the Rohde & Schwarz SMA, or HP 8644B signal generators or an equivalent. Use a 1 m shielded, RG-58, 50 Ω coaxial cable for connecting to the evaluation board. Enter the desired frequency and amplitude (see the Specifications section in the data sheet of the respective part). When connecting the analog input source, use of a multipole, narrow-band band-pass filter with 50 Ω terminations is recommended. Analog Devices, Inc., uses TTE and K&L Microwave, Inc., band-pass filters. The filters should be connected directly to the evaluation board.

If an external clock source is used, it should also be supplied with a clean signal generator as previously specified. Typically, most Analog Devices evaluation boards can accept ~2.8 V p-p or 13 dBm sine wave input for the clock.

### OUTPUT SIGNALS

The default setup uses the Analog Devices high speed converter evaluation platform (HSC-ADC-EVALCZ) for data capture. The CMOS output signals from Channel A and Channel B are buffered through U801 and U802 and are routed through P903 and P902, respectively, to the FPGA on the data capture board.

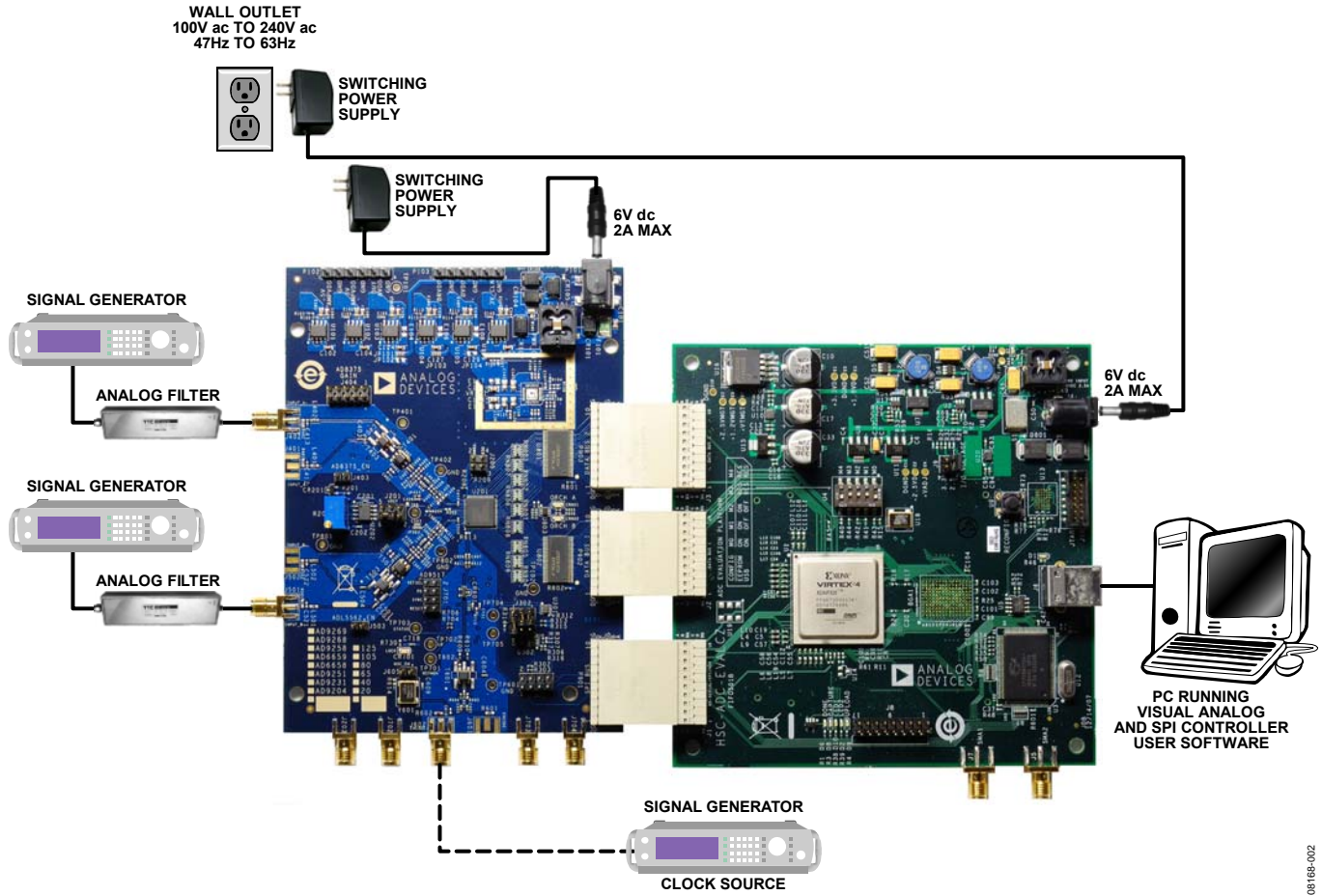

Figure 2. Evaluation Board Connection

09168-002

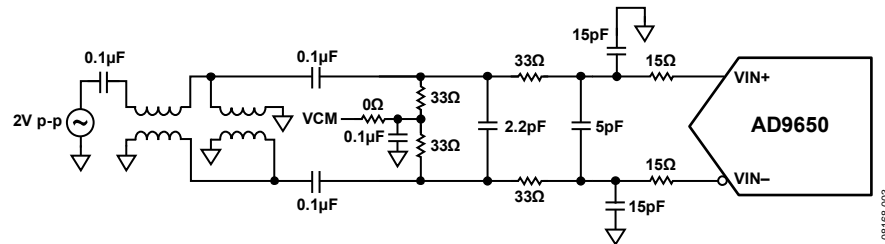

Figure 3. Default Analog Input Configuration of the AD9650 Family

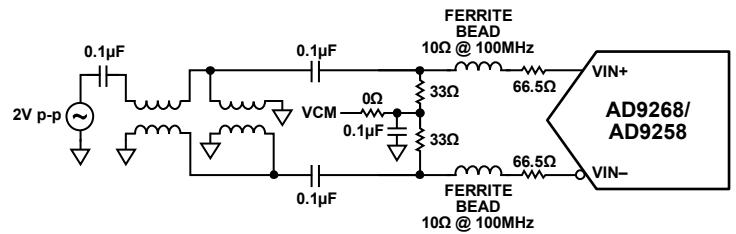

Figure 4. Default Analog Input Configuration of the AD9268 Family

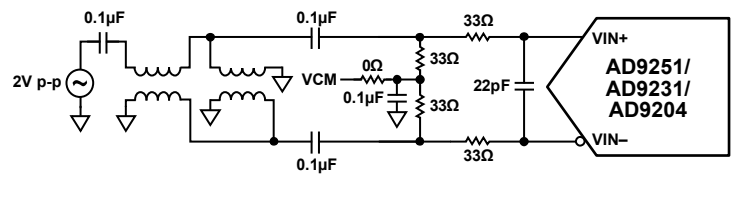

Figure 5. Default Analog Input Configuration of the AD9269 Family

## DEFAULT OPERATION AND JUMPER SELECTION SETTINGS

This section explains the default and optional settings or modes allowed on the [AD9650/AD9268/AD9258/AD9251/AD9231/AD9204/AD9269/AD6659](#) Rev. C evaluation board.

### Power Circuitry

Connect the switching power supply that is supplied in the evaluation kit between a rated 100 V ac to 240 V ac wall outlet at 47 Hz to 63 Hz and P101.

### Analog Input

The A and B channel inputs on the evaluation board are set up for a double balun-coupled analog input with a 50 Ω impedance.

#### AD9650 Family

The default input network, as configured on the AD9650 evaluation board, is shown in Figure 3

#### AD9268 Family

For the AD9268 family, the default analog input configuration supports analog input frequencies of up to ~250 MHz (see Figure 4). This input network is optimized to support a wide frequency band. See the AD9258 and AD9268 data sheets for additional information on the recommended networks for different input frequency ranges.

#### AD9269 Family

For the AD9269 family, the default analog input configuration supports analog input frequencies of up to ~150 MHz (see Figure 5). The nominal input drive level is 10 dBm to achieve 2 V p-p full scale into 50 Ω. At higher input frequencies, slightly higher input drive levels are required due to losses in the front-end network.

Optionally, the Channel A input on the board can be configured to use the [AD8375](#) digitally variable gain amplifier (DVGA). The AD8375 component is included on the evaluation board at U401. However, the path into and out of the AD8375 can be configured in many different ways depending on the application; therefore, the parts in the input and output path are left unpopulated. Users should see the AD8375 data sheet for additional information on this part and for configuring the inputs and outputs. The AD8375 by default is held in power-down mode but can be enabled by adding a jumper on J403.

The Channel B input is also set up with an optional input path through the [ADL5562](#) ultralow distortion RF/IF differential amplifier. Similar to Channel A, the amplifier is included on the board at U501; however, the input-/output-related components are not included. Users should see the ADL5562 data sheet for additional information on this part and for configuring the inputs and outputs. The ADL5562 is also normally held in power-down mode and can be enabled by adding a jumper on J503. The ADL5562 on the Channel B input can also be substituted with the [ADA4937](#) or the [ADA4938](#) to allow evaluation of these parts with the ADC.

**VREF**

The default VREF configuration is to connect the SENSE pin to AGND for internal VREF operation. This is done by connecting Pin 4 and Pin 6 on Header J201. Table 2 summarizes the internal VREF voltage for the different families of ADCs.

**Table 2. Default VREF Configuration**

Family Name	Internal VREF (V)	Full-Scale Range (V p-p)
AD9650	1.35	2.7
AD9268	1	2
AD9269	1	2

The AD9650 and AD9269 families operate with a fixed reference. For the AD9268 family, the reference voltage can be changed to 0.5 V for a 1.0 V p-p full-scale range by moving the SENSE pin jumper connection on J201 from Pin 4 through Pin 6 to Pin 3 through Pin 4 (this connects the SENSE pin to the VREF pin).

To use the programmable reference mode for the AD9268 family, a resistor divider can be set up by installing R204 and R205. The jumper on J201 should be removed for this mode of operation. See the data sheet of the specific part for the additional information on using the programmable reference mode.

A separate unpopulated external reference option using the AD1580 reference and the AD822 amplifier is also included on the evaluation board. To enable the external reference populate CR201, U202, R202, R201, C201, and C202 with the values shown in the Evaluation Board Schematics and Artwork section and Bill of Materials section. The J201 jumper should be placed between Pin 4 and Pin 2 to set the reference input to the external reference mode.

**RBIAS**

RBIAS has a default setting of 10 k $\Omega$  (R206) to ground and is used to set the ADC core bias current. Note that using a resistor value other than a 10 k $\Omega$ , 1% resistor for RBIAS may degrade the performance of the device.

**Clock Circuitry for the AD9269 Family**

The default clock input circuit on the AD9269 evaluation board family uses a simple transformer-coupled circuit using a high bandwidth 1:1 impedance ratio transformer (T601) that adds a low amount of jitter to the clock path. The clock input is 50  $\Omega$  terminated and ac-coupled to handle single-ended sine wave types of inputs. The transformer converts the single-ended input to a differential signal that is clipped by CR601 before entering the ADC clock inputs.

The AD9269 evaluation board family is by default set up to be clocked through the transformer-coupled input network from the crystal oscillator, Y601. This oscillator is a low phase noise oscillator from Valpey Fisher (VFAC3-BHL-40MHz/VFAC3-BHL-65MHz/VFAC3-BHL-80MHz). If a different clock source is desired, remove J605 to disable the oscillator from running and connect the external clock source to the SMA connector, J602 (labeled ENCODE+).

**Clock Circuitry for the AD9650 and the AD9268 Family**

The default clock input circuit on the AD9650 and AD9268 family evaluation boards uses a similar circuit to the AD9269 family but uses a higher bandwidth 1:1 impedance ratio balun (T602) that adds a low amount of jitter to the clock path. The clock input is again 50  $\Omega$  terminated and ac-coupled to handle single-ended sine wave types of inputs. The balun converts the single-ended input to a differential signal that is clipped before entering the ADC clock inputs.

The board is set by default to use an external clock generator. An external clock source capable of driving a 50  $\Omega$  terminated input should be connected to J602. This family is shipped from Valpey Fisher with a low phase noise oscillator installed. The oscillator frequency is set to match the rated speed of the part: 125 MHz, 105 MHz, or 80 MHz for the AD9268 family and 105 MHz, 80 MHz, 65 MHz, or 25 MHz for the AD9650 family. To enable the oscillator, install J605, and to connect it into the clock path, add a 0  $\Omega$  resistor at C610. R602 should also be removed to remove the 50  $\Omega$  termination from the output of the oscillator.

A differential LVPECL clock driver output can also be used to clock the ADC input using the AD9517 (U701). To place the AD9517 into the clock path, populate R607 and R608 with 0  $\Omega$  resistors and remove R609 and R610 to disconnect the default clock path inputs. In addition, populate R731 and R732 with 0  $\Omega$  resistors and remove R611 and R612 to disconnect the default clock path outputs and insert the AD9517 LVPECL Output 3. The AD9517 must be configured through the SPI controller software to set up the PLL and other operation modes. Consult the AD9517 data sheet for more information about these and other options.

**PDWN**

To enable the power-down feature, add a shorting jumper across J205 at Pin 1 and Pin 2 to connect the PDWN pin to DRVDD.

**OE**

To disable the outputs using the  $\overline{\text{OE}}$  pin, add a shorting jumper across J205 at Pin 3 and Pin 4 to connect the  $\overline{\text{OE}}$  pin to DRVDD.

**Non-SPI Mode**

For users who want to operate the DUT without using SPI, remove the shorting jumpers on J302. This disconnects the  $\overline{\text{CS}}$ , SCLK/DFS, and SDIO/DCS pins from the SPI control bus, allowing the DUT to operate in non-SPI mode. In this mode, the SCLK/DFS and SDIO/DCS pins take on their alternate functions to select the data format and enable/disable the DCS. With the jumpers removed, DCS is disabled; to enable DCS, add a shorting jumper on J302 between Pin 2 to Pin 3. With the jumper removed, the data format is set to offset binary. To set the data format to twos complement, a jumper should be added on J302 between Pin 5 and Pin 6.

**Switching Power Supply**

Optionally, the ADC on the board can be configured to use the [ADP2114](#) dual switching power supply to provide power to the DRVDD and AVDD rails of the ADC. To configure the board to operate from the ADP2114, the following changes must be incorporated (see the Evaluation Board Schematics and Artwork and Bill of Materials sections for specific recommendations for part values):

1. Install R120 and R122 to enable the ADP2114.
2. Install R107 and R109.
3. Install R110, R111, C108, and C109.
4. Install R108, R118, C110, C111, C112, and C113.
5. Install L101, L102, E116, and E117.
6. Install R125 and R127.
7. Remove JP101 and JP103 and install JP102 and JP104.
8. Remove E103, E105, and E107 and install E104, E106, and E108.

Making these changes enables the switching converter to power the ADC. Using the switching converter as the ADC power source is more efficient than using the default LDOs.

## EVALUATION BOARD SOFTWARE QUICK START PROCEDURES

This section provides quick start procedures for using the [AD9650](#), [AD9268](#), [AD9258](#), [AD9251](#), [AD9231](#), [AD9204](#), [AD9269](#), and [AD6659](#) evaluation board. Both the default and optional settings are described.

### CONFIGURING THE BOARD

Before using the software for testing, configure the evaluation board as follows:

1. Connect the evaluation board to the data capture board, as shown in Figure 1 and Figure 2.
2. Connect one 6 V, 2.5 A switching power supply (such as the CUI, Inc., EPS060250UH-PHP-SZ supplied) to the AD9650, AD9268, AD9258, AD9251, AD9231, AD9204, AD9269, or AD6659 board.
3. Connect one 6 V, 2.5 A switching power supply (such as the CUI EPS060250UH-PHP-SZ supplied) to the HSC-ADC-EVALCZ board.
4. Connect the HSC-ADC-EVALCZ board (J6) to the PC with a USB cable.
5. On the ADC evaluation board, confirm that three jumpers are installed on J302, one between Pin 1 and Pin 2, one between Pin 4 and Pin 5, and one between Pin 8 and Pin 9, to connect the SPI bus to the DUT.
6. If using an AD9269 family board, ensure that J605 (OSC\_EN) has a jumper installed to use the on-board 50 MHz/65 MHz/80 MHz Valpey Fisher VFAC3 oscillator. If using an AD9650 or AD9268 family board, make sure a low jitter sample clock is applied at J602.
7. On the ADC evaluation board, use a clean signal generator with low phase noise to provide an input signal to the desired A and/or B channel(s). Use a 1 m, shielded, RG-58, 50  $\Omega$  coaxial cable to connect the signal generator. For best results, use a narrow-band, band-pass filter with 50  $\Omega$  terminations and an appropriate center frequency. (Analog Devices uses TTE, Allen Avionics, and K&L band-pass filters.)

### USING THE SOFTWARE FOR TESTING

#### Setting Up the ADC Data Capture

After configuring the board, set up the ADC data capture using the following steps:

1. Open VisualAnalog on the connected PC. The appropriate part type should be listed in the status bar of the **VisualAnalog – New Canvas** window. Select the template that corresponds to the type of testing to be performed (see Figure 6 where the AD9268 is shown as an example).

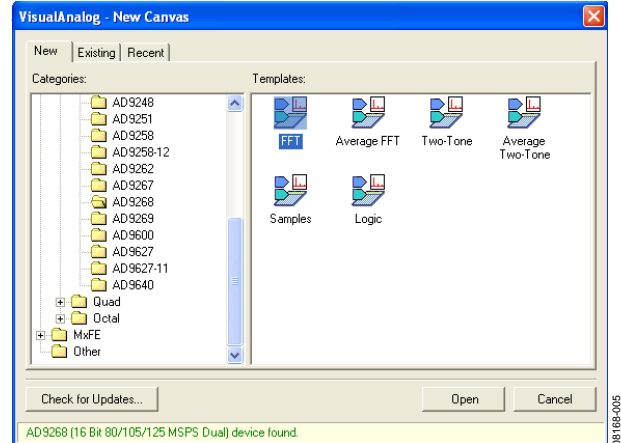

Figure 6. VisualAnalog, New Canvas Window

2. After the template is selected, a message appears asking if the default configuration can be used to program the FPGA (see Figure 7). Click **Yes** and the window closes.

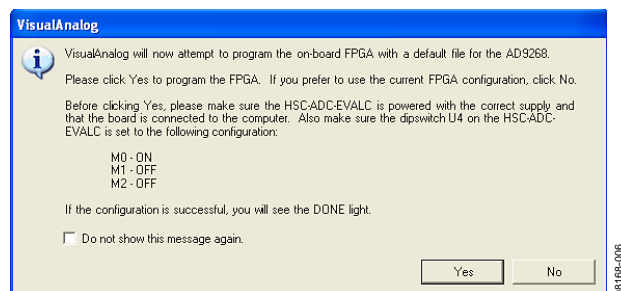

Figure 7. VisualAnalog Default Configuration Message

3. To change features to settings other than the default settings, click the **Expand Display** button, located on the bottom right corner of the window, to see what is shown in Figure 9. Detailed instructions for changing the features and capture settings can be found in the [AN-905 Application Note, VisualAnalog Converter Evaluation Tool Version 1.0 User Manual](#). After the changes are made to the capture settings, click **Collapse Display** (see Figure 8).

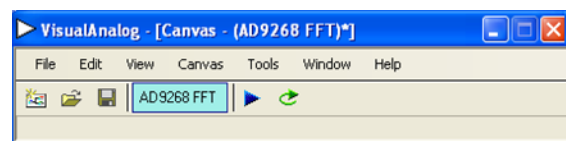

Figure 8. VisualAnalog Window Toolbar, Collapsed Display

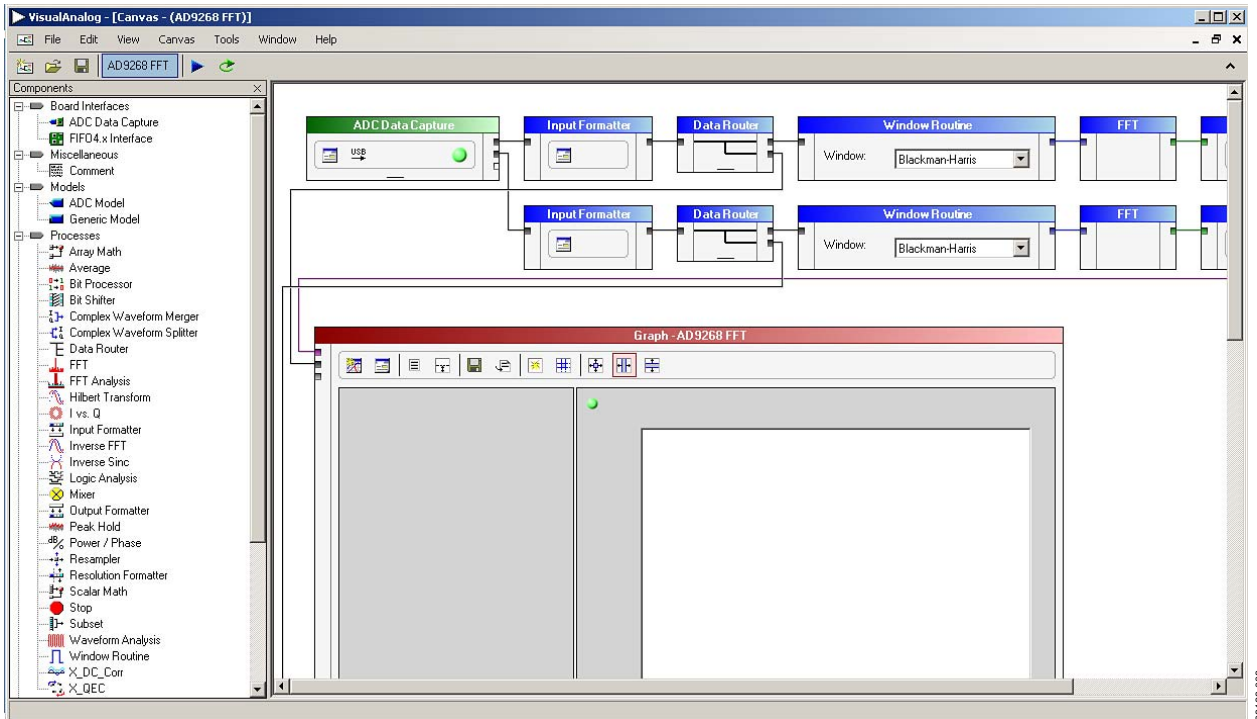

Figure 9. VisualAnalog, Main Window

### Setting Up the SPI Controller Software

After the ADC data capture board setup is complete, set up the SPI controller software using the following procedure:

1. Open the SPI controller software by going to the **Start** menu or by double-clicking the **SPIController** software desktop icon. If prompted for a configuration file, select the appropriate one. If not, check the title bar of the window to determine which configuration is loaded. If necessary, choose **Cfg Open** from the **File** menu and select the appropriate file based on your part type. Note that the **CHIP ID(1)** field should be filled to indicate whether the correct SPI controller configuration file is loaded (see Figure 10).

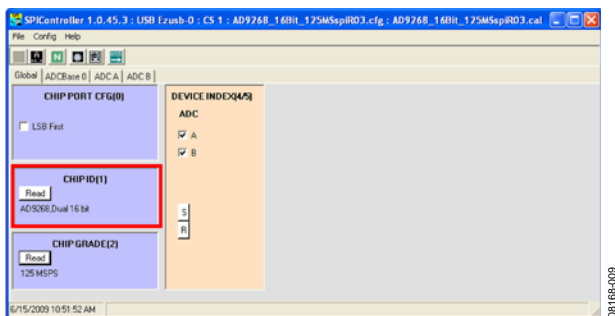

Figure 10. SPI Controller, CHIP ID(1) Box

2. Click the **New DUT** button in the **SPIController** window (see Figure 11).

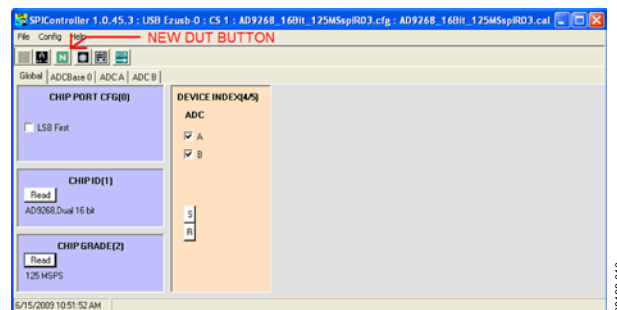

Figure 11. SPI Controller, New DUT Button

3. In the **ADCBASE 0** tab of the **SPIController** window, find the **CLOCK DIVIDE(B)** box (see Figure 12). If using the clock divider, use the drop-down box to select the correct clock divide ratio, if necessary. See the appropriate part data sheet; the **AN-878** Application Note, *High Speed ADC SPI Control Software*; and the **AN-877** Application Note, *Interfacing to High Speed ADCs via SPI*, for additional information.

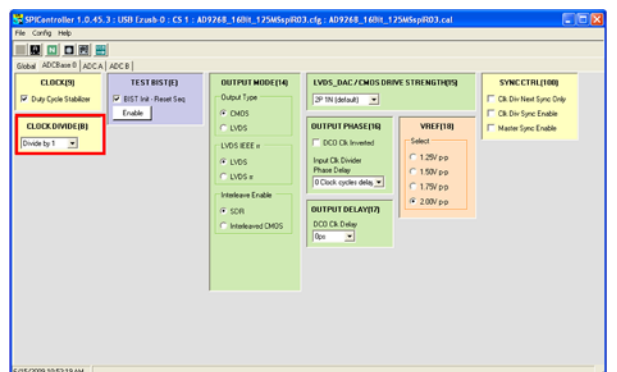

Figure 12. SPI Controller, CLOCK DIVIDE(B) Box

- Note that other settings can be changed on the **ADCBASE 0** page (see Figure 12) and the **ADC A** and **ADC B** pages (see Figure 13) to set up the part in the desired mode. The **ADCBASE 0** page settings affect the entire part, whereas the settings on the **ADC A** and **ADC B** pages affect the selected channel only. See the appropriate part data sheet; the [AN-878](#) Application Note, *High Speed ADC SPI Control Software*; and the [AN-877](#) Application Note, *Interfacing to High Speed ADCs via SPI*, for additional information on the available settings.

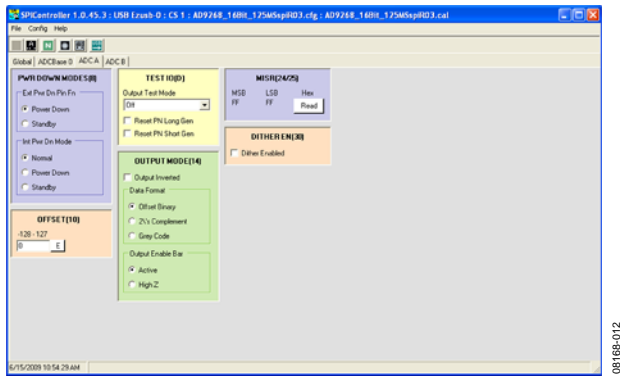

Figure 13. SPI Controller, Example ADC A Page

- Click the **Run** button in the **VisualAnalog** toolbar (see Figure 14).

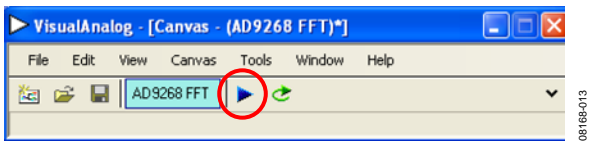

Figure 14. Run Button (Encircled in Red) in VisualAnalog Toolbar, Collapsed Display

### Adjusting the Amplitude of the Input Signal

The next step is to adjust the amplitude of the input signal for each channel as follows:

- Adjust the amplitude of the input signal so that the fundamental is at the desired level. Examine the **Fund Power** reading in the left panel of the **VisualAnalog Graph - AD9268 Average FFT** window (see Figure 15).

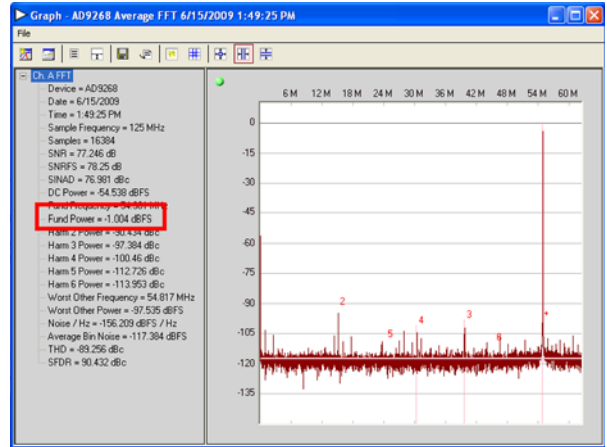

Figure 15. Graph Window of VisualAnalog

- Repeat this procedure for Channel B.
- Click the disk icon within the **Graph** window to save the performance plot data as a .csv formatted file. See Figure 16 for an example.

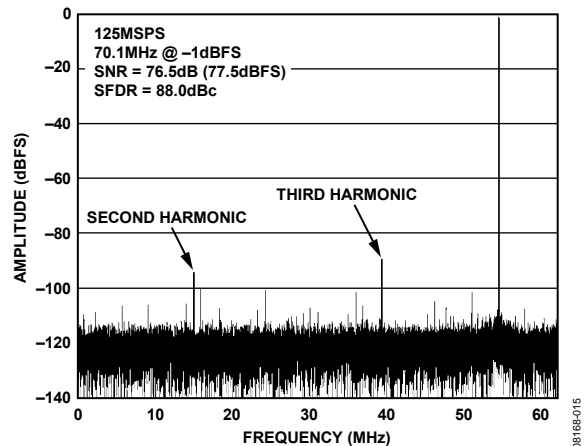

Figure 16. Typical FFT, AD9268/AD9258

**Troubleshooting Tips**

If the FFT plot appears abnormal, do the following:

- If you see a normal noise floor when you disconnect the signal generator from the analog input, be sure you are not overdriving the ADC. Reduce the input level, if necessary.
- In **VisualAnalog**, click the **Settings** button in the **Input Formatter** block. Check that **Number Format** is set to the correct encoding (offset binary by default). Repeat for the other channel.

If the FFT appears normal but the performance is poor, check the following:

- Make sure an appropriate filter is used on the analog input.
- Make sure the signal generators for the clock and the analog input are clean (low phase noise).
- Change the analog input frequency slightly if noncoherent sampling is being used.
- Make sure the SPI config file matches the product being evaluated.

If the FFT window remains blank after **Run** is clicked, do the following:

- Make sure the evaluation board is securely connected to the HSC-ADC-EVALCZ board.
- Make sure the FPGA has been programmed by verifying that the **DONE** LED is illuminated on the HSC-ADC-EVALCZ board. If this LED is not illuminated, make sure the U4 switch on the board is in the correct position for USB CONFIG.
- Make sure the correct FPGA program was installed by selecting the **Settings** button in the **ADC Data Capture** block in **VisualAnalog**. Then select the **FPGA** tab and verify that the proper FPGA bin file is selected for the part.

If **VisualAnalog** indicates that the **FIFO Capture timed out**, do the following:

- Make sure all power and USB connections are secure.
- Probe the DCOA signal at RN801 (Pin 2) on the evaluation board and confirm that a clock signal is present at the ADC sampling rate.

EVALUATION BOARD SCHEMATICS AND ARTWORK

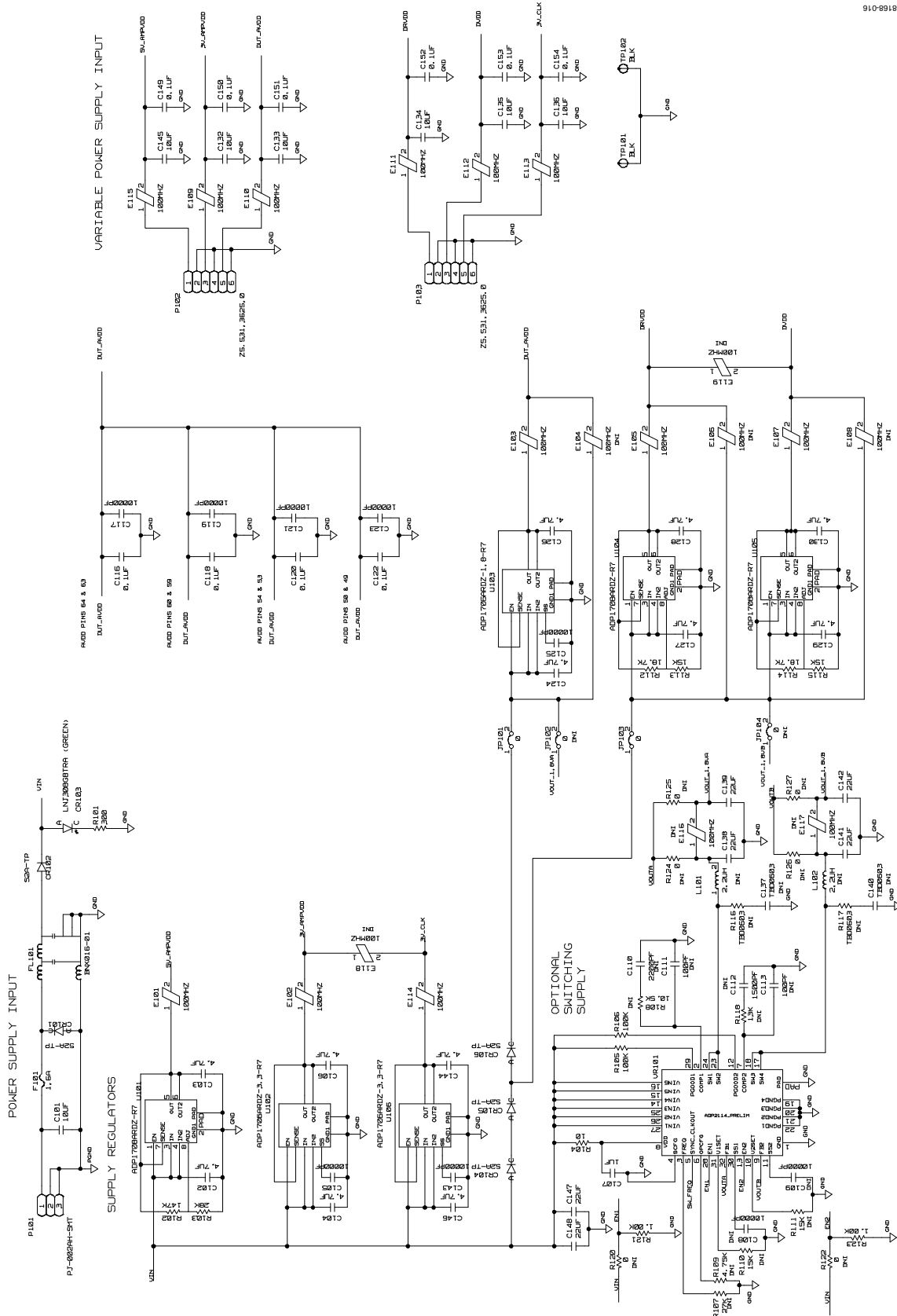

Figure 17. Board Power Input and Supply Circuits  
 Rev. A | Page 12 of 40

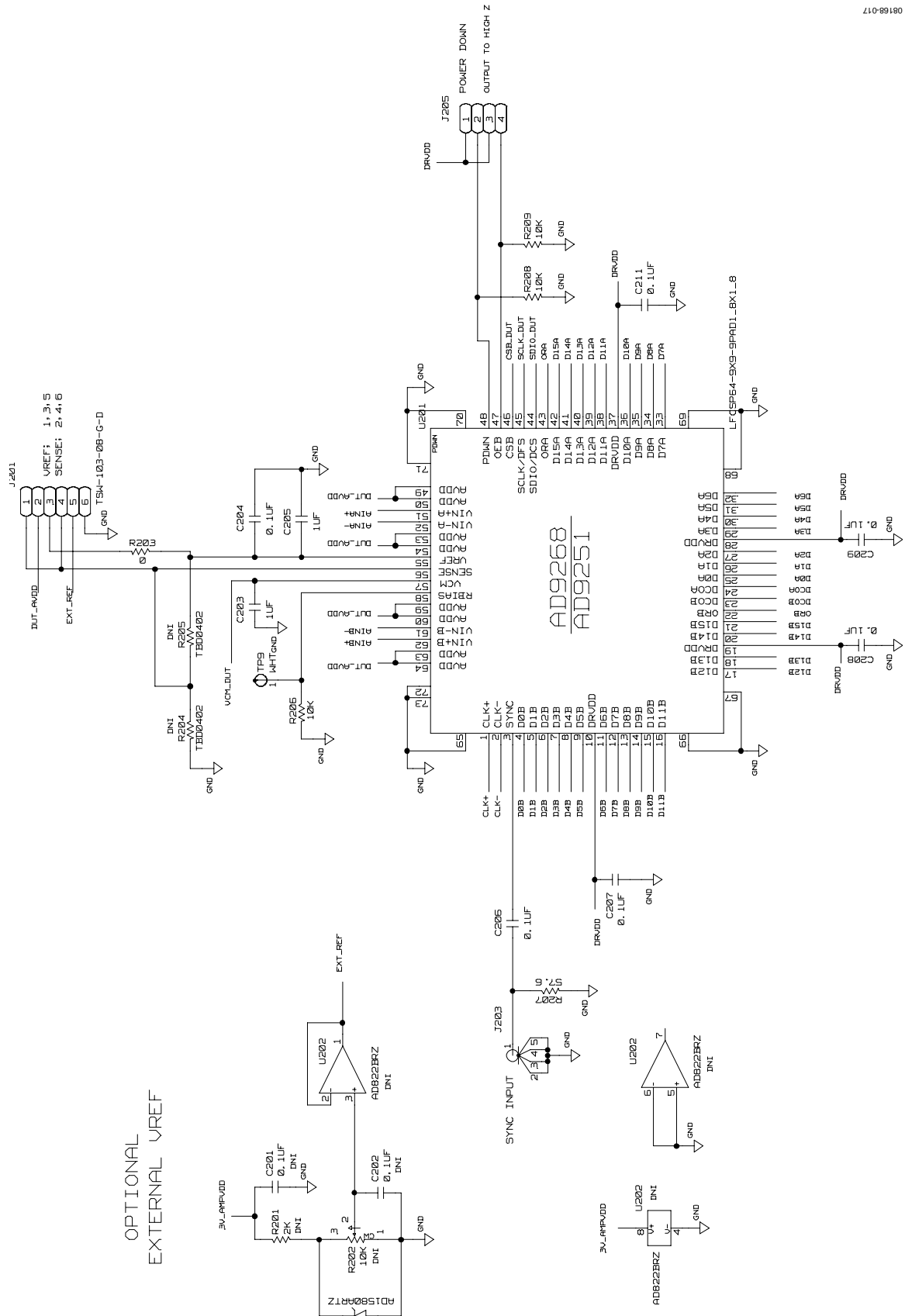
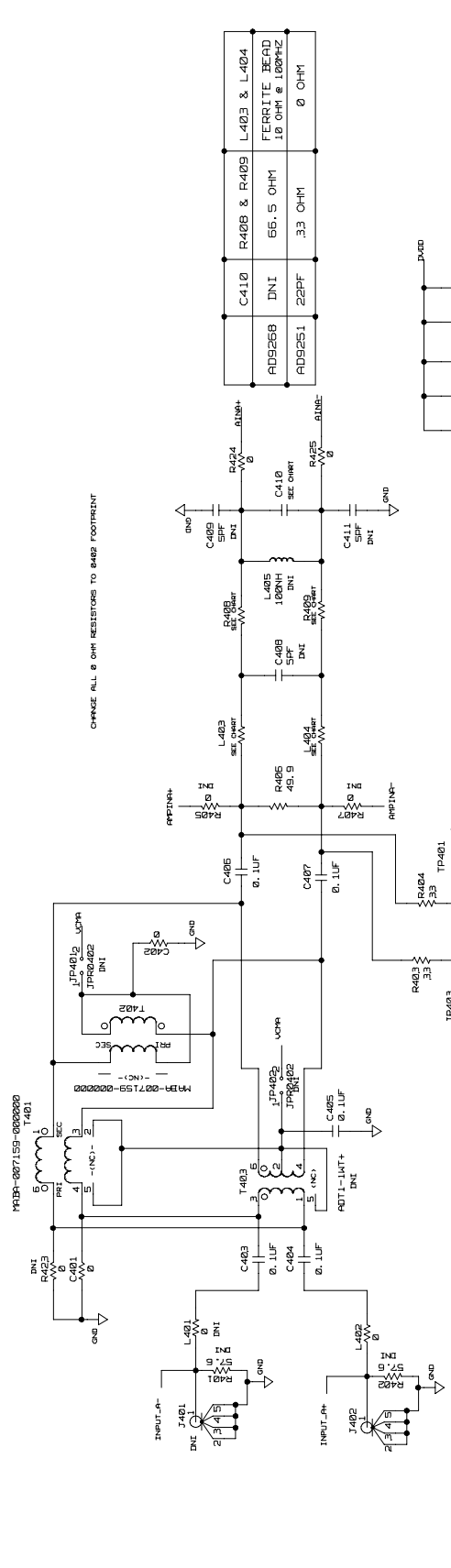

Figure 18. DUT and Related Circuits



DEFAULT ANALOG INPUT CIRCUITRY CHA



CHANGE ALL 8 OHM RESISTORS TO 8482 FOOTPRINT

OPTIONAL ANALOG INPUT CIRCUITRY CHA

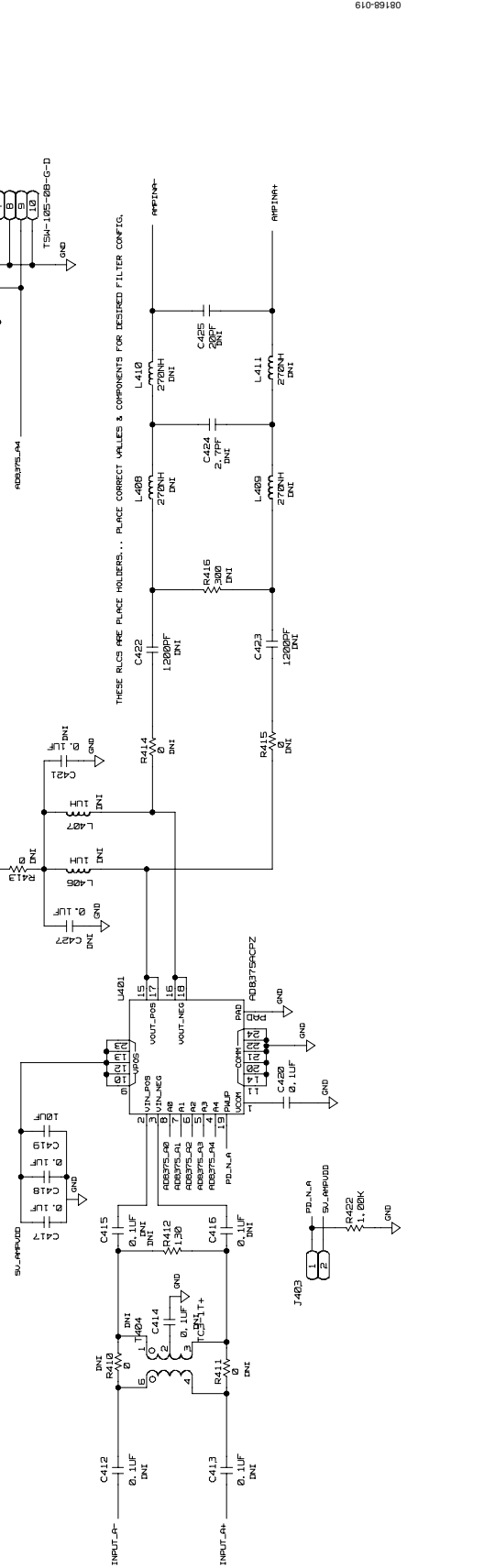

THESE VALUES ARE PLACE HOLDERS... PLACE CORRECT VALUES & COMPONENTS FOR DESIRED FILTER CONFIG.

THIS HEADER IS USED TO SELECT THE GAIN OF THE ADS375.

Figure 20. Channel A Input Circuits

DEFAULT ANALOG INPUT CIRCUITRY CHB

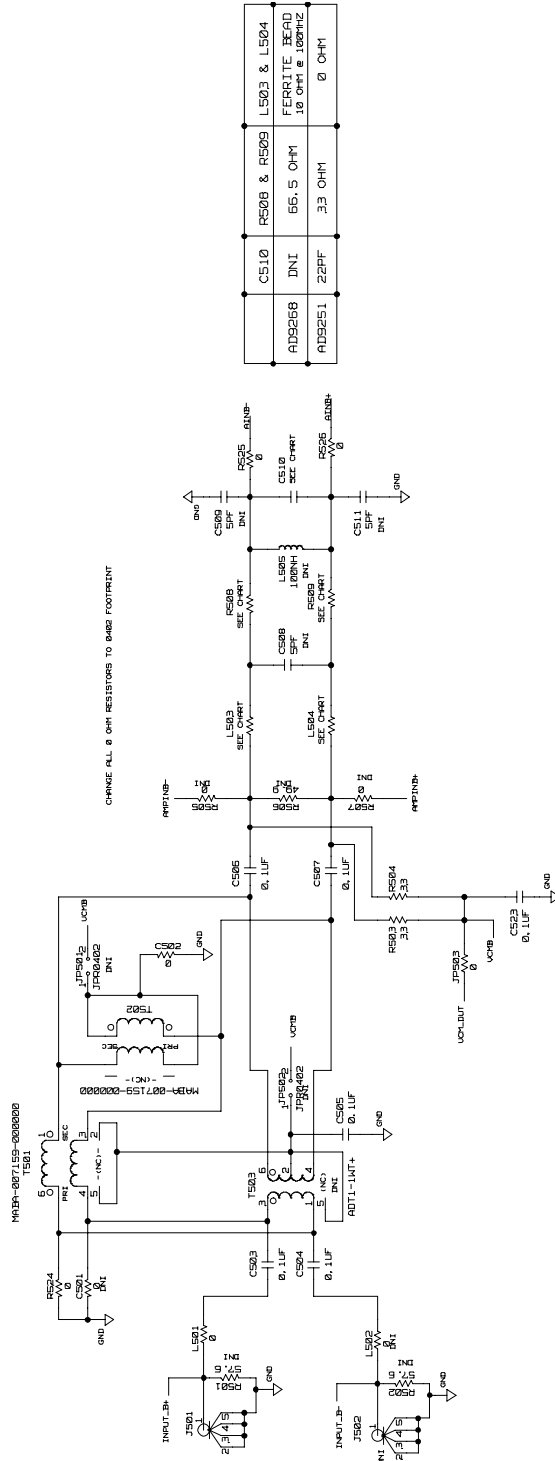

OPTIONAL ANALOG INPUT CHB

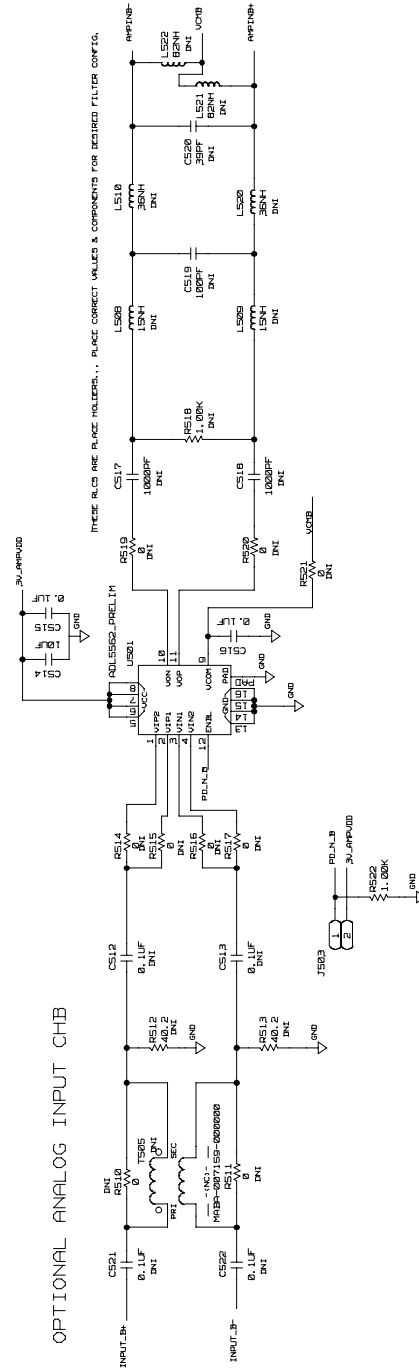
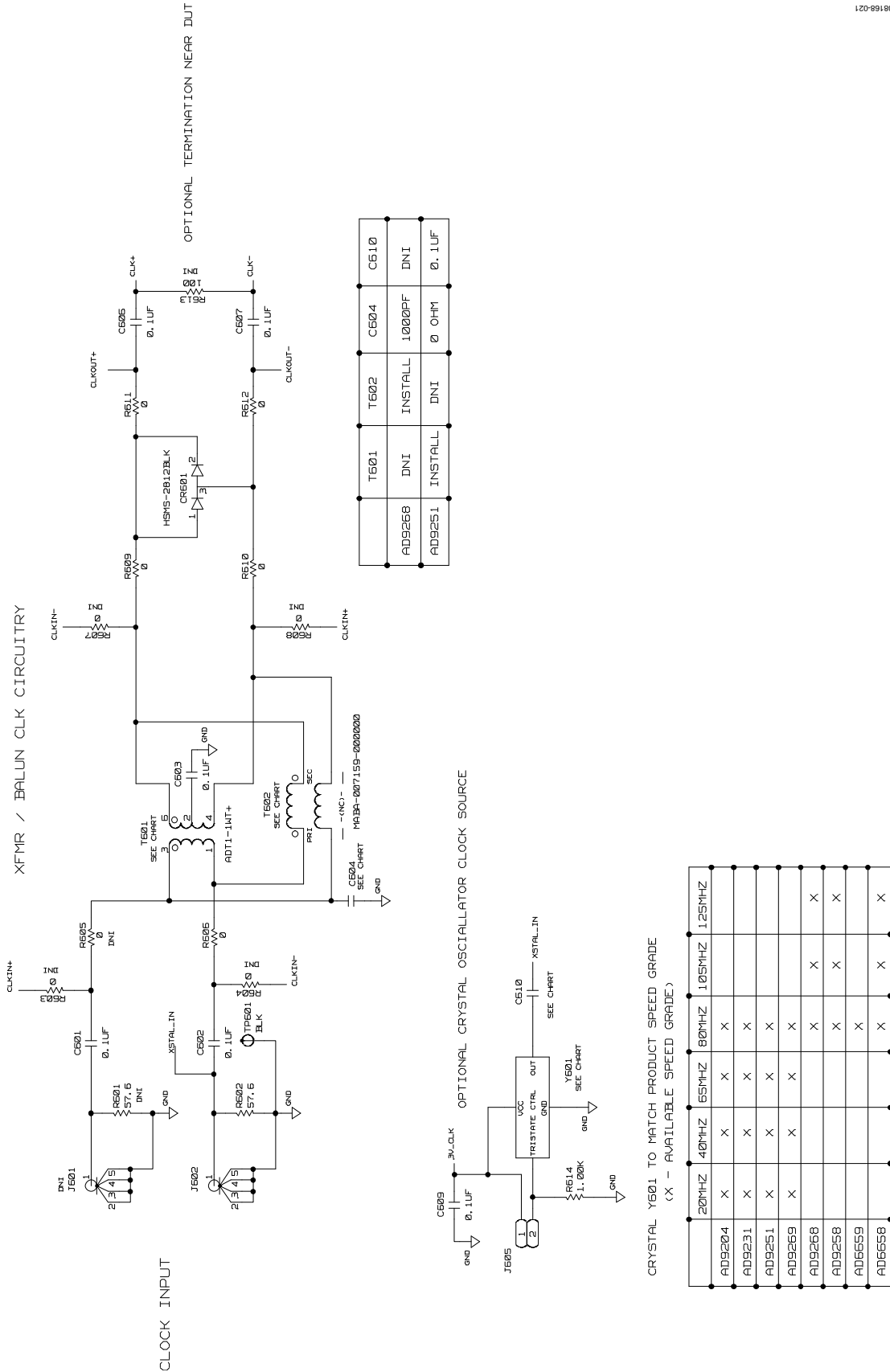

Figure 21. Channel B Analog Input Circuits



T601	T602	C610
AD9268	INSTALL	DNI
AD9251	INSTALL	0 OHM
		0.1UF

CRYSTAL Y601 TO MATCH PRODUCT SPEED GRADE  
(X - AVAILABLE SPEED GRADE)

	20MHz	40MHz	65MHz	80MHz	105MHz	125MHz
AD9204	X	X	X	X		
AD9231	X	X	X	X		
AD9251	X	X	X	X		
AD9269	X	X	X	X		
AD9268				X	X	X
AD9258				X	X	X
AD6559				X	X	X
AD6558				X	X	X

Figure 22. Default Clock Path Input Circuits

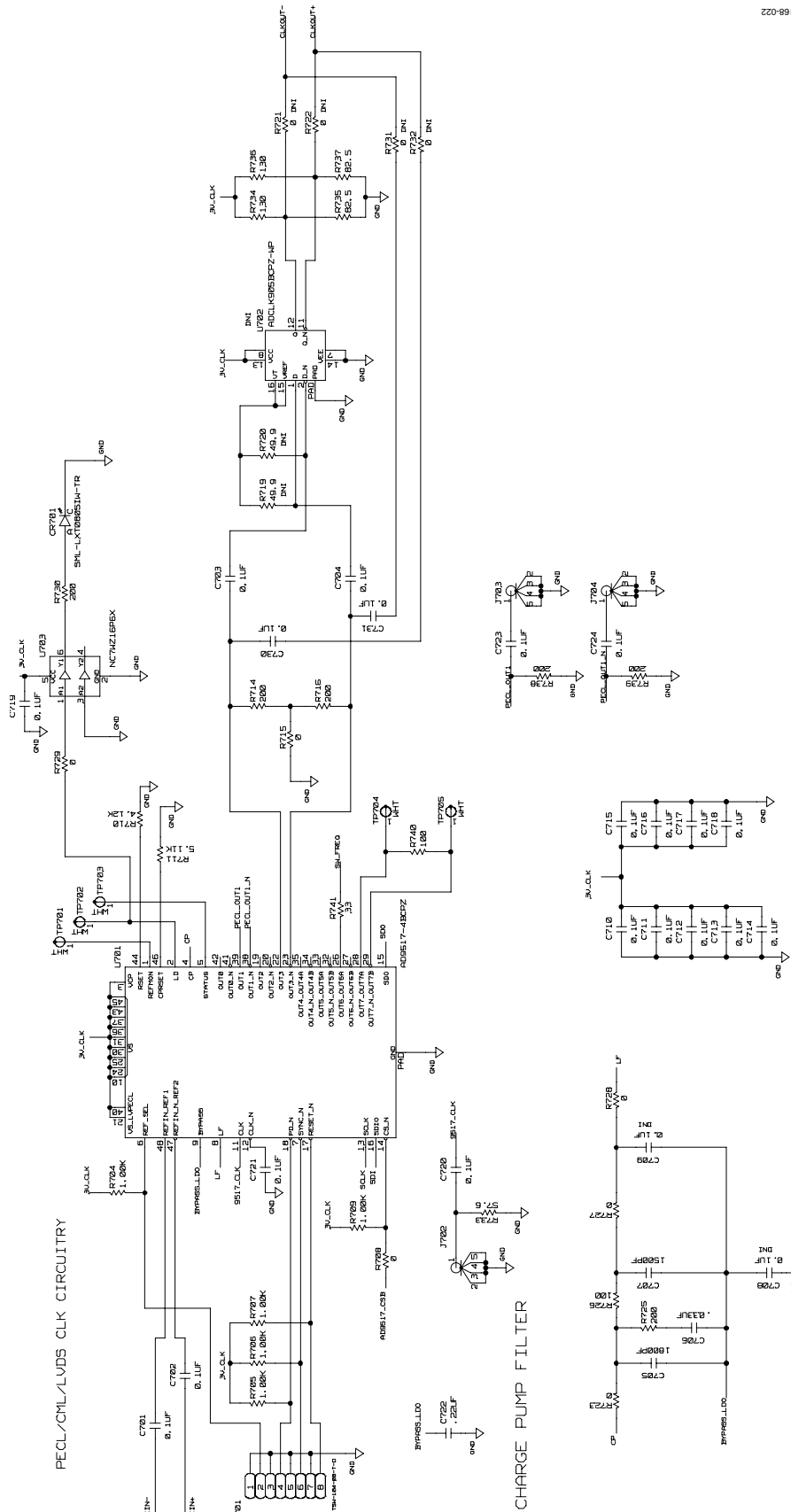

Figure 23. Optional AD9517 Clock Input Circuit

SERIES RESISTORS

CHANNEL B		CHANNEL A	
DC09	RNB01	08A	RNB03
	3 $\times$ W/5		1 $\times$ W/5
	11B9		119A
	SEE CHART		SEE CHART
05B	RNB01	D15A	RNB03
	4 $\times$ W/5		2 $\times$ W/7
	11B9		119A
	SEE CHART		SEE CHART
D15B	RNB08	D14A	RNB03
	1 $\times$ W/8		2 $\times$ W/7
	1179		117A
	SEE CHART		SEE CHART
D14B	RNB09	D13A	RNB03
	2 $\times$ W/7		4 $\times$ W/5
	11B9		116A
	SEE CHART		SEE CHART
D13B	RNB08	D12A	RNB07
	3 $\times$ W/5		1 $\times$ W/8
	11B9		115A
	SEE CHART		SEE CHART
D12B	RNB08	D11A	RNB07
	4 $\times$ W/5		2 $\times$ W/7
	114B		114A
	SEE CHART		SEE CHART
D11B	RNB05	D10A	RNB07
	1 $\times$ W/8		3 $\times$ W/5
	113B		113A
	SEE CHART		SEE CHART
D10B	RNB05	D9A	RNB07
	2 $\times$ W/7		4 $\times$ W/5
	112B		112A
	SEE CHART		SEE CHART
D9B	RNB05	D8A	RNB02
	3 $\times$ W/5		1 $\times$ W/8
	111B		111A
	SEE CHART		SEE CHART
D8B	RNB05	D7A	RNB02
	4 $\times$ W/5		2 $\times$ W/7
	110B		110A
	SEE CHART		SEE CHART
D7B	RNB09	D6A	RNB02
	1 $\times$ W/8		3 $\times$ W/5
	19B		19A
	SEE CHART		SEE CHART
D6B	RNB09	D5A	RNB02
	2 $\times$ W/7		4 $\times$ W/5
	19B		19A
	SEE CHART		SEE CHART
D5B	RNB09	D4A	RNB05
	3 $\times$ W/5		1 $\times$ W/8
	17B		17A
	SEE CHART		SEE CHART
D4B	RNB09	D3A	RNB05
	4 $\times$ W/5		2 $\times$ W/7
	16B		16A
	SEE CHART		SEE CHART
D3B	RNB04	D2A	RNB05
	1 $\times$ W/8		3 $\times$ W/5
	15B		15A
	SEE CHART		SEE CHART
D2B	RNB04	D1A	RNB05
	2 $\times$ W/7		4 $\times$ W/5
	14B		14A
	SEE CHART		SEE CHART
D1B	RNB04	D0A	RNB01
	3 $\times$ W/5		1 $\times$ W/8
	13B		13A
	SEE CHART		SEE CHART
D0B	RNB04	DC0A	RNB01
	4 $\times$ W/5		2 $\times$ W/7
	12B		12A
	SEE CHART		SEE CHART

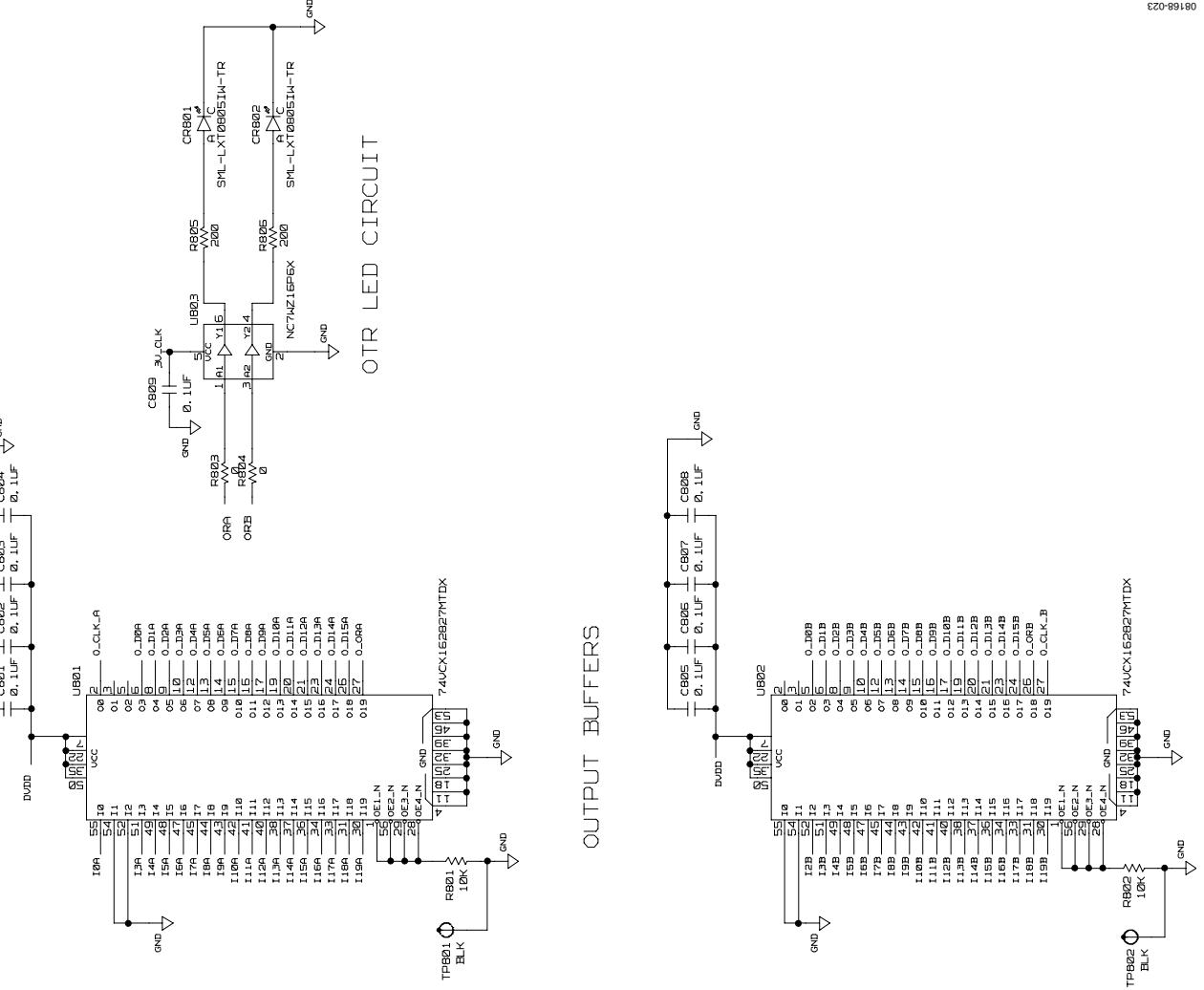
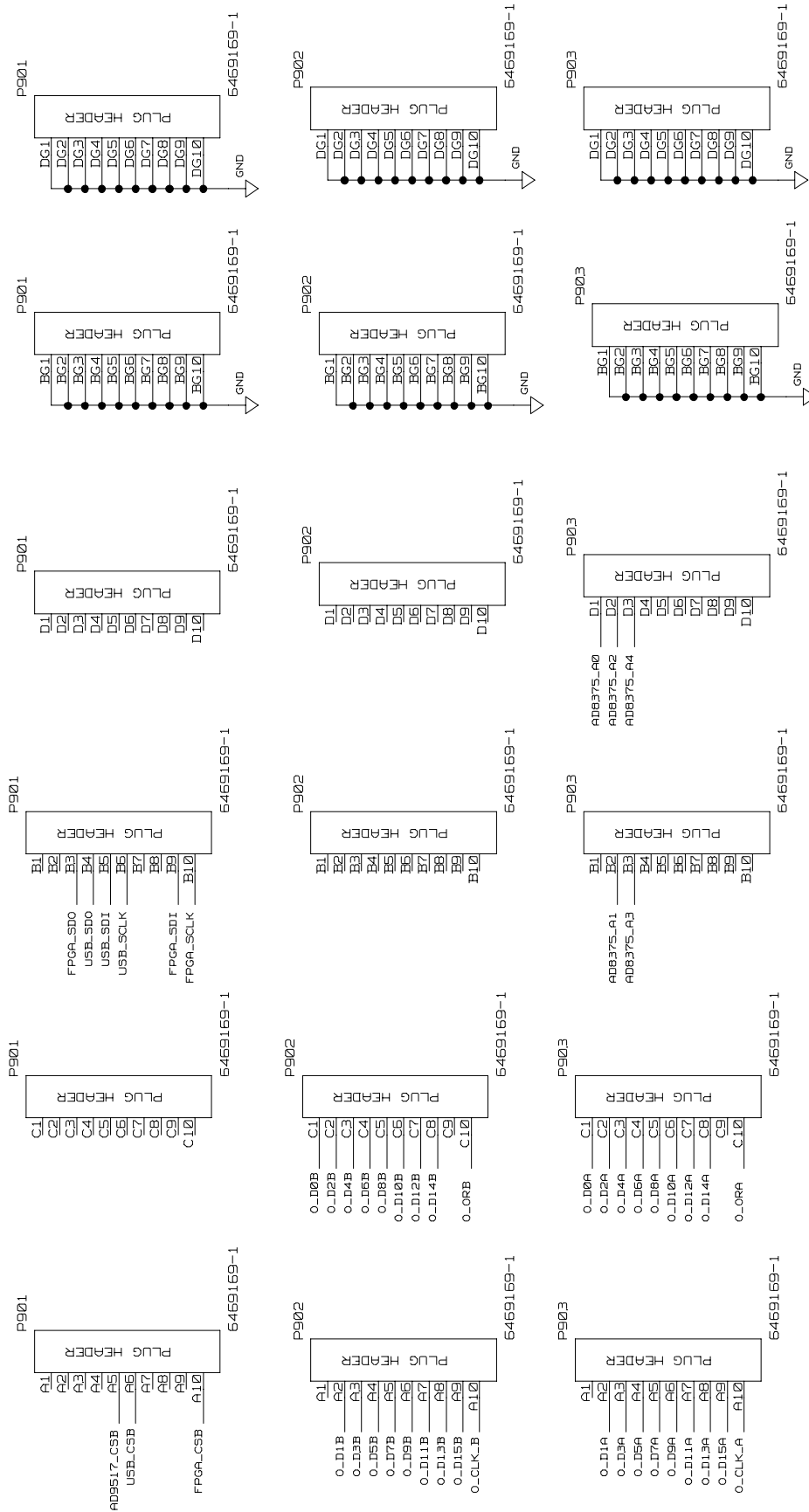

Figure 24. Output Buffer Circuits



FIFO 5 CONNECTIONS

08168-024

Figure 25. FIFO Board Connector

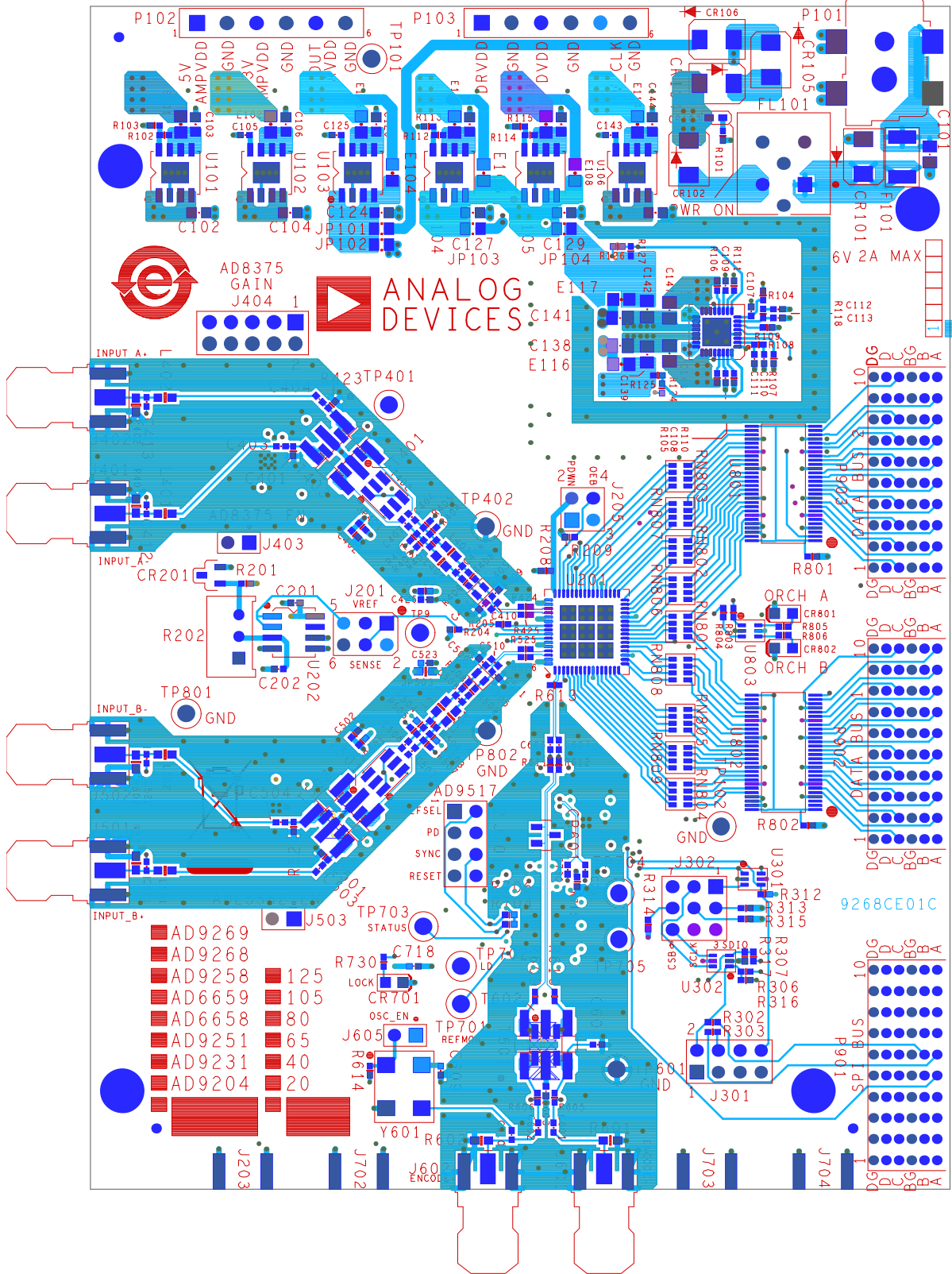
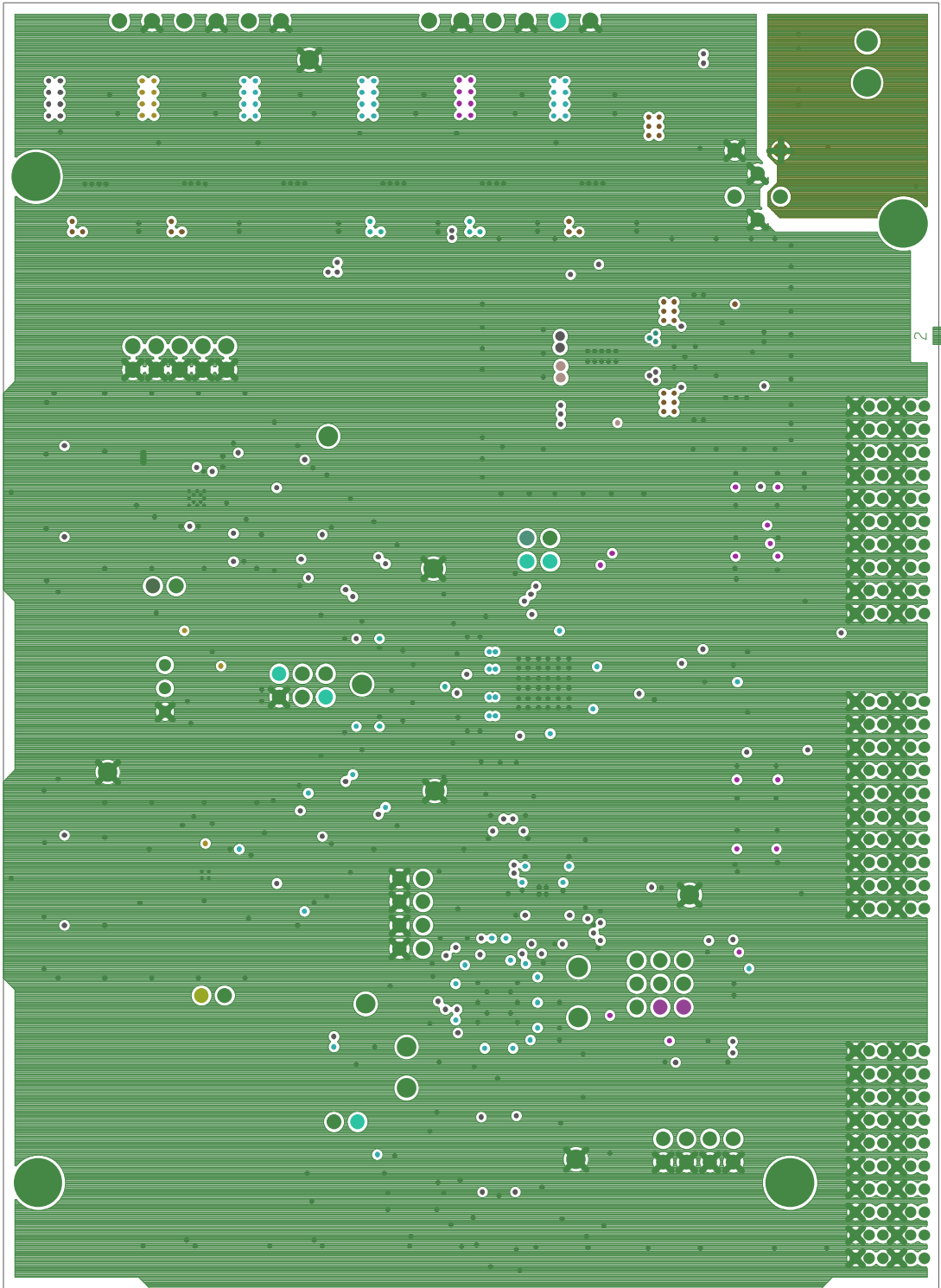

Figure 26. Top Side



08168-026

Figure 27. Ground Plane (Layer 2)

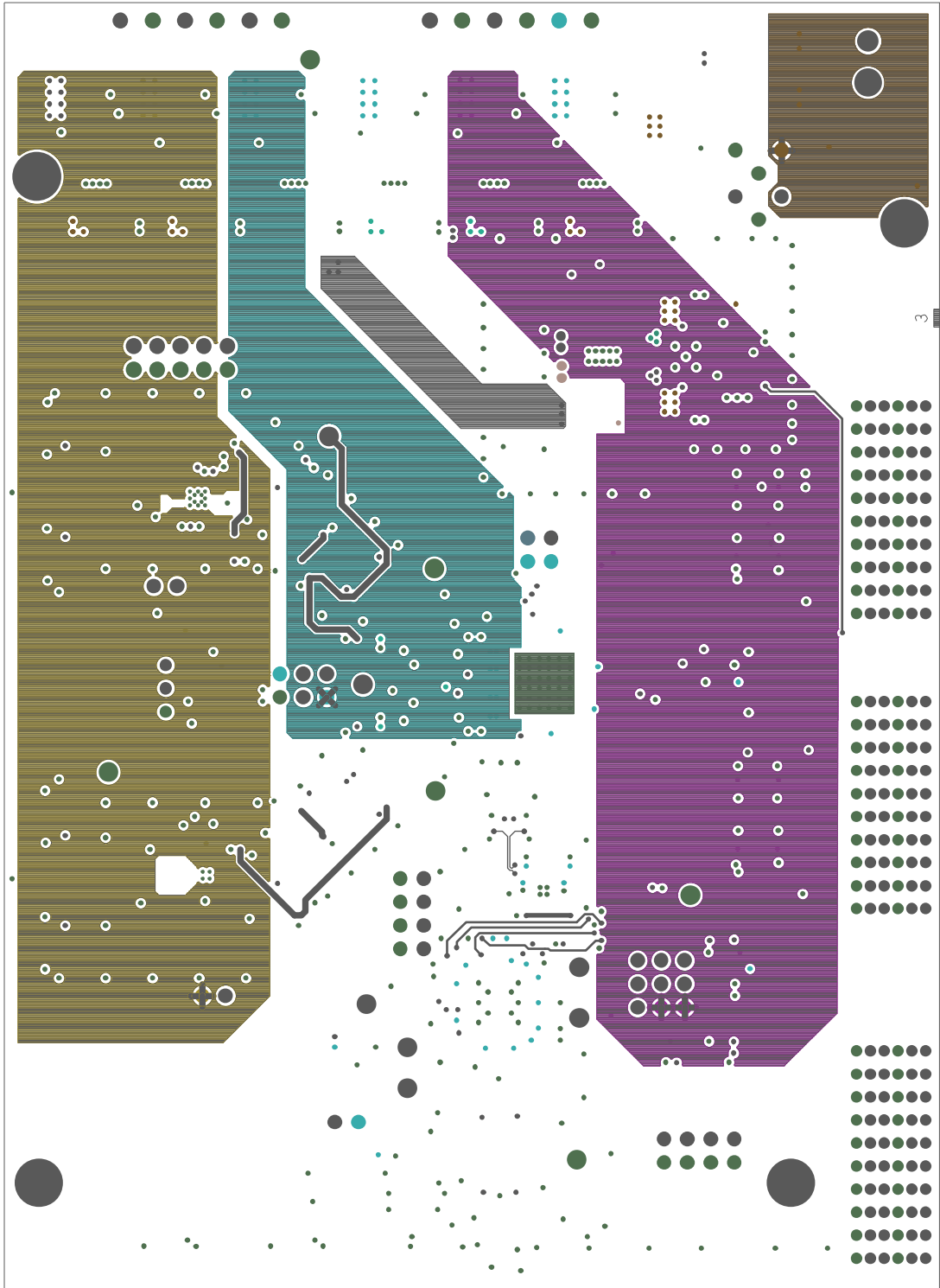
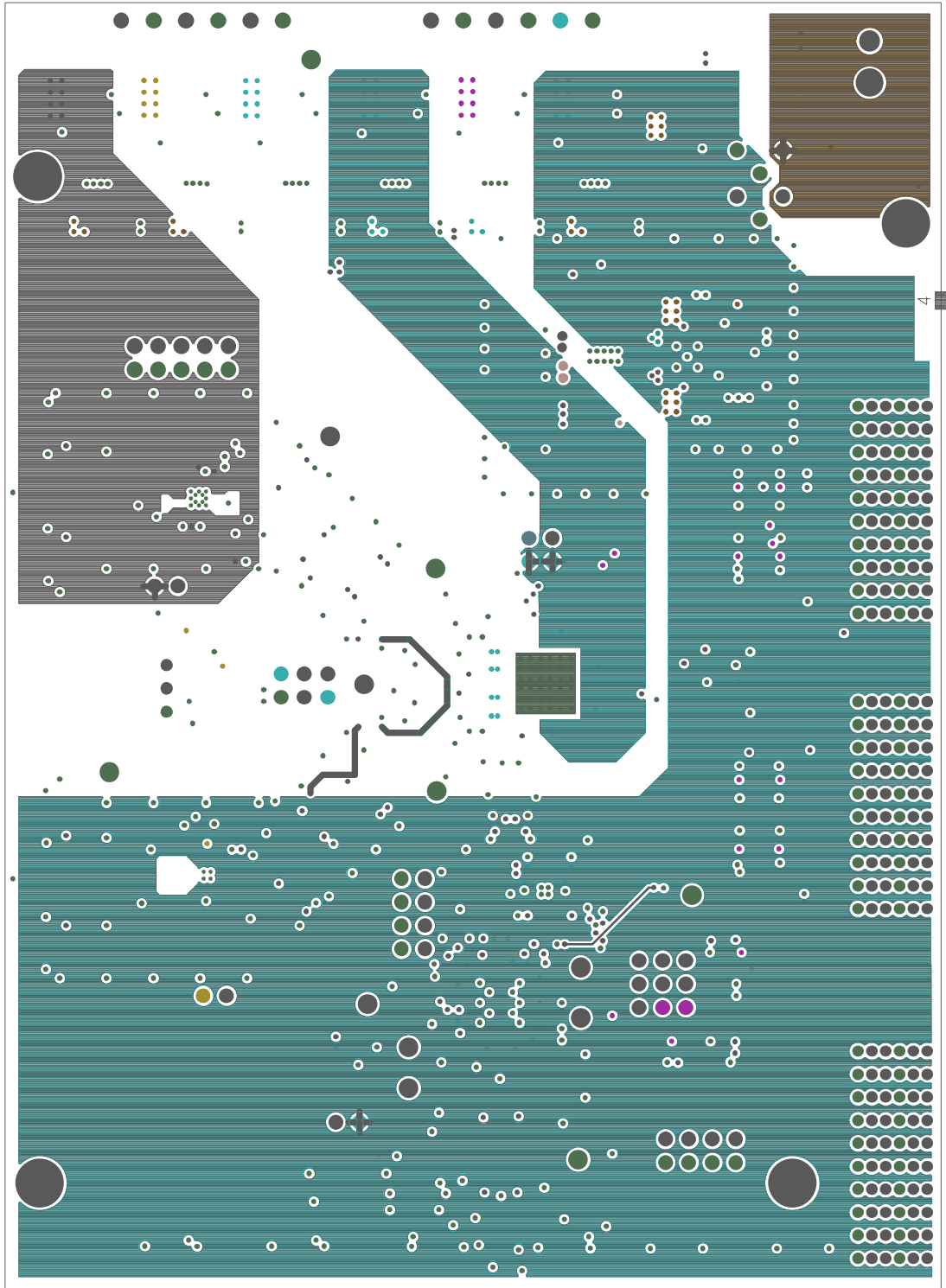

Figure 28. Power Plane (Layer 3)

08168-427



08168-028

Figure 29. Power Plane (Layer 4)

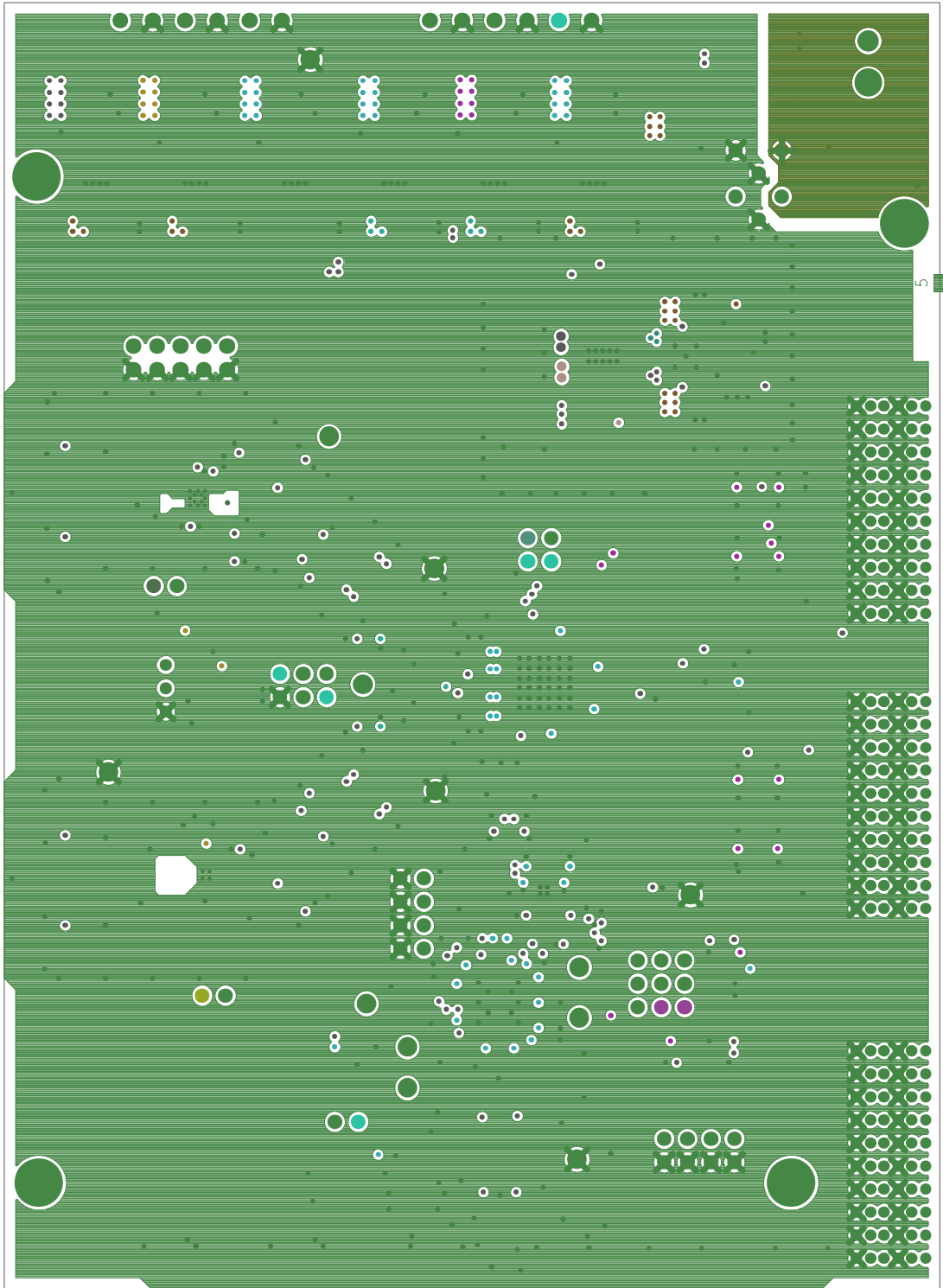

Figure 30. Ground Plane (Layer 5)

08168-029

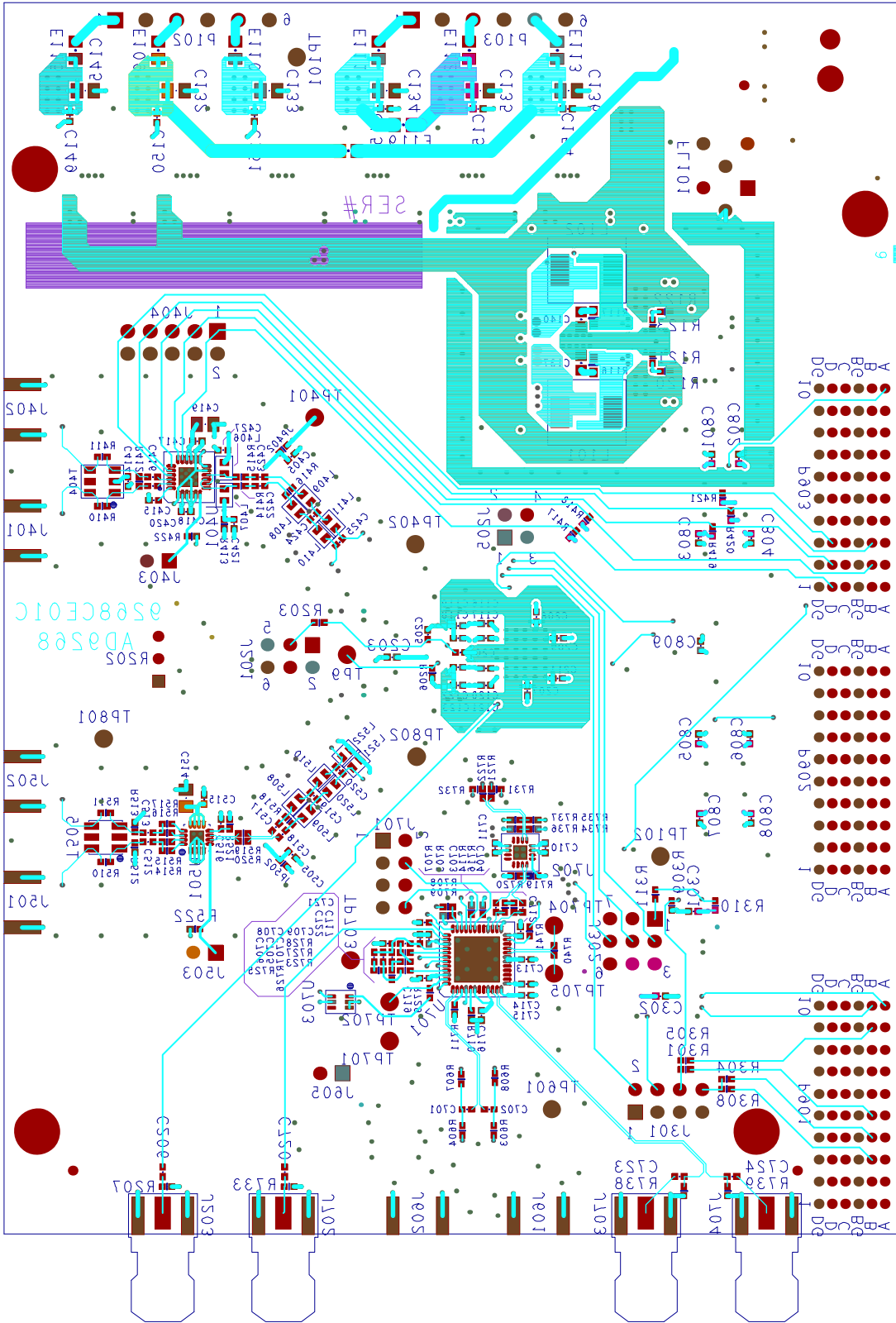

Figure 31. Bottom Side

## ORDERING INFORMATION

### BILL OF MATERIALS

Table 3. AD9650 Family BOM

Item	Qty	Reference Designator	Description	Value	Manufacturer/Part No.
1 <sup>1</sup>	0	C108, C109	Capacitor, ceramic, X7R, 0402	0.01 $\mu$ F, 25 V	Panasonic/ECJ-0EB1E103K
2 <sup>1</sup>	0	C110	Capacitor, ceramic, X7R, 0402	2.2 nF, $\pm$ 10%, 25 V	Phycomp (Yageo)/0402R222K8B20D
3 <sup>1</sup>	0	C111, C113, C519	Capacitor, ceramic, C0G, 0402	100 pF, 50 V, 5%	Murata/GRM1555C1H101JD01D
4 <sup>1</sup>	0	C112	Capacitor, ceramic, X7R, 0402	1500 pF, 50 V	Panasonic/ECJ-0EB1H152K
5 <sup>1</sup>	0	C137, C140			
6A	2	C408, C508	Capacitor, ceramic, C0G, 0402	2.2pF, 50 V	Murata/GRM1555C1H2R2CZ01D
6B	4	C409, C411, C509, C511	Capacitor, ceramic, C0G, 0402	15 pF, 50 V, 5%	Murata/GRM1555C1H150JZ01D
6C	2	C410, C510	Capacitor, ceramic, C0G, 0402	5.0 pF, 50 V	Murata/GRM1555C1H5R0CZ01D
7 <sup>1</sup>	0	C201, C202, C412, C413, C414, C415, C416, C421, C427, C512, C513, C521, C522, C610, C703, C704, C708, C709			
8 <sup>1</sup>	0	C422, C423	Capacitor, ceramic, X7R, 0402	0.1 $\mu$ F, 16 V	Panasonic/ECJ-0EX1C104K
9 <sup>1</sup>	0	C424	Capacitor, ceramic, SMD, 0402	1200 pF, 25 V	Panasonic/ECJ-0EB1E122K
10 <sup>1</sup>	0	C425	Capacitor, ceramic	CL05C2R7CBNC	Samsung/CL05C2R7CBNC
11 <sup>1</sup>	0	C517, C518	Capacitor, ceramic, C0G, 0402	20 pF, 50 V, 5%,	Murata/GRM1555C1H200JZ01D
12 <sup>1</sup>	0	C520	Capacitor, ceramic, SMD, 0402	ECU-E1E102KBQ	Panasonic/ECU-E1E102KBQ
13 <sup>1</sup>	0	E104, E106, E108, E116, E117, E118, E119	Capacitor, ceramic	0402CG390J9B200	Phycomp (Yageo)/0402CG390J9B200
14 <sup>1</sup>	0	J401, J502, J601, J702, J703, J704	Bead core, 0805, SMD	4 A, 100 MHz	Panasonic/EXC-ML20A390U
15 <sup>1</sup>	0	JP102, JP104	SMA straight, edge-mount stack	50 $\Omega$	Samtec/SMA-J-P-X-ST-EM1
16 <sup>1</sup>	0	L101, L102	Inductors		
17 <sup>1</sup>	0	L401, L502	Fixed inductors	FDV0630-2R2M	TOKO/FDV0630-2R2M
18 <sup>1</sup>	0	L405, L505	Resistor, 0603, SMD	0.0 $\Omega$ , 1/10 W	Panasonic/ERJ-3GEY0R00V
19 <sup>1</sup>	0	L406, L407	Ceramic chip inductor	0603CS-R10XGLU	Coilcraft/0603CS-R10XGLU
20 <sup>1</sup>	0	L408, L409, L410, L411	Chip inductor	0603LS-102XGLB	Coilcraft/0603LS-102XGLB
21 <sup>1</sup>	0	L508, L509	Ceramic chip inductor	0603CS-R27XGLW	Coilcraft/0603CS-R27XGLW
22 <sup>1</sup>	0	L510, L520	Chip inductor	0603CS-15NXGLU	Coilcraft/0603CS-15NXGLU
23 <sup>1</sup>	0	L521, L522	Chip inductor	0603CS-36NXGLU	Coilcraft/0603CS-36NXGLU
24 <sup>1</sup>	0	R107	Ceramic chip inductor	0603CS-82NXGLU	Coilcraft/0603CS-82NXGLU
25 <sup>1</sup>	0	R108	Resistor, 0402, SMD	10.0 $\Omega$ , 1/10 W, 1%	Panasonic/ERJ-2RKF10R0X
26 <sup>1</sup>	0	R109	Resistor, 0402, SMD	100 k $\Omega$ , 1/10 W, 1%	Panasonic/ERJ-2RKF1003X
27 <sup>1</sup>	0	R110, R111	Resistor, 0402, SMD	27.0 k $\Omega$ , 1/10 W, 1%	Panasonic/ERJ-2RKF2702X
28 <sup>1</sup>	0	R116, R117	Resistor, 0402, SMD	105 k $\Omega$ , 1/16 W, 1%	Panasonic/ERJ-2RKF1052X
29 <sup>1</sup>	0	R118	Resistor, 0402, SMD	4.75 k $\Omega$ , 1/10 W, 1%	Panasonic/ERJ-2RKF4751X

Item	Qty	Reference Designator	Description	Value	Manufacturer/Part No.
30 <sup>1</sup>	0	C501, R120, R122, R124, R125, R126, R127, R305, R306, R307, R308, R405, R407, R410, R411, R413, R414, R415, R423, R505, R507, R510, R511, R514, R515, R516, R517, R519, R520, R521, R603, R604, R605, R607, R608, R721, R722, R731, R732	Resistor, 0402, SMD	0.0 Ω, 1/10 W	Panasonic/ERJ-2GE0R00X
31 <sup>1</sup>	0	R518	Resistor, 0402, SMD	1.00 kΩ, 1/10 W, 1%	Panasonic/ERJ-2RKF1001X
32 <sup>1</sup>	0	R201	Resistor, 0402, SMD	2.00 kΩ, 1/10 W, 1%	Panasonic/ERJ-2RKF2001X
33 <sup>1</sup>	0	R202	POT	3299W-1-103	Bourns/3299W-1-103
34 <sup>1</sup>	0	R204, R205			
35 <sup>1</sup>	0	R401, R402, R501, R502, R601	Resistor, 0603, SMD	57.6 Ω, 1/10 W, 1%	Panasonic/ERJ-3EKF57R6V
36 <sup>1</sup>	0	R406, R506, R719, R720	Resistor, 0402, SMD	49.9 Ω, 1/10 W, 1%	Panasonic/ERJ-2RKF49R9X
37 <sup>1</sup>	0	R412	Resistor, 0402, SMD	130 Ω, 1/10 W, 1%	Panasonic/ERJ-2RKF1300X
38 <sup>1</sup>	0	R416	Resistor, 0402, SMD	300 Ω, 1/16 W, 5%	Panasonic/ERJ-2GEJ301X
39 <sup>1</sup>	0	R417, R418, R419, R420, R421	Resistor, 0402, SMD	10.0 kΩ, 1/10 W, 1%	Panasonic/ERJ-2RKF1002X
40 <sup>1</sup>	0	R512, R513	Resistor, 0402, SMD	40.2 Ω, 1/10 W, 1%	Panasonic/ERJ-2RKF40R2X
41 <sup>1</sup>	0	R613	Resistor, 0402, SMD	100 Ω, 1/10 W, 5%	Panasonic/ERJ-2GEJ101X
42 <sup>1</sup>	0	T403, T503	Surface-mount RF transformer	ADT1-1WT	Mini-Circuits/ADT1-1WT
43 <sup>1</sup>	0	T404	Surface-mount RF transformer	TC3-1T+	Mini-Circuits/TC3-1T+
44 <sup>1</sup>	0	T505	RF 1:1 transmission line transformer	MABA-007159-000000	M/A-COM/MABA-007159-000000
45 <sup>1</sup>	0	T601			
46 <sup>1</sup>	0	TP101, TP102, TP402, TP601, TP801, TP802	Black test point	TP-104-01-00	Components Corp./TP-104-01-00
47 <sup>1</sup>	0	TP9, TP401, TP701, TP702, TP703, TP704, TP705	White test point	TP-104-01-09	Components Corp./TP-104-01-09
48 <sup>1</sup>	0	U702	Ultrafast SiGe ECL clock/data buffers	ADCLK905BCPZ-WP	Analog Devices/ADCLK905BCPZ-WP
49 <sup>1</sup>	0	CR201	1.2 V micropower, precision shunt voltage reference	AD1580ARTZ	Analog Devices/AD1580ARTZ
50 <sup>1</sup>	0	U202	Single-supply, rail-to-rail low power FET-input op amp	AD822BRZ	Analog Devices, Inc./AD822BRZ
52	9	C101, C132, C133, C134, C135, C136, C145, C419, C514	Capacitor, ceramic, X5R, 0805	10 μF, 6.3 V	Panasonic/ECJ-2FBOJ106M
53	12	C102, C103, C104, C106, C124, C126, C127, C128, C129, C130, C144, C146	Capacitor, ceramic, X5R, 0603	4.7 μF, 6.3 V	Panasonic/ECJ-1VB0J475M
54	7	C105, C117, C119, C121, C123, C125, C143	Capacitor, ceramic, X7R, 0402	0.01 μF, 25 V	Panasonic/ECJ-0EB1E103K

Item	Qty	Reference Designator	Description	Value	Manufacturer/Part No.
55	68	C116, C118, C120, C122, C149, C150, C151, C152, C153, C154, C204, C206, C207, C208, C209, C211, C301, C302, C401, C404, C405, C406, C407, C417, C418, C420, C426, C503, C505, C506, C507, C515, C516, C523, R524, C601, C602, C603, C606, C607, C609, C701, C702, C710, C711, C712, C713, C714, C715, C716, C717, C718, C719, C720, C721, C723, C724, C730, C731, C801, C802, C803, C804, C805, C806, C807, C808, C809	Capacitor, ceramic, X7R, 0402	0.1 $\mu$ F, 16 V	Murata/81-GRM155R71C104KA88, Panasonic/ECJ-0EX1C104K
55A <sup>1</sup>	0	C403, C504	Capacitor, ceramic, X7R, 0402	0.1 $\mu$ F, 16 V	Murata/81-GRM155R71C104KA88, Panasonic/ECJ-0EX1C104K
56	6	C138, C139, C141, C142, C147, C148	Capacitor, ceramic, X5R, 0805	22 $\mu$ F, 6.3 V, 20%	Murata/GRM21BR60J226ME39L
57	3	C107, C203, C205	Capacitor, ceramic, Y5V, 0402	1 $\mu$ F, 6.3 V	Panasonic/ECJ-0EF0J105Z
58A	21	C402, C502, JP403, R203, R301, R302, R303, R304, R606, R609, R610, R611, R612, R708, R715, R723, R727, R728, R729, R803, R804	Resistor, 0402, SMD	0 $\Omega$ , 1/10 W, 5%	Yageo/RC0402JR-070RL, Panasonic/ERJ-2GE0R00X
58B	4	R424, R425, R525, R526	Resistor, 0402, SMD	15.0 $\Omega$ , 1/16 W, 1%	Panasonic/ERJ-2RKF15R0X
59	1	C604	Capacitor, ceramic, 0402, SMD	1000 pF, 25 V	Panasonic/ECJ-0EB1E102K
60	1	C705	Capacitor, ceramic, 0402, SMD	1800 pF, 25 V	Panasonic/ECJ-0EB1E182K
61	1	C706	Capacitor, ceramic, X5R, 0402	0.033 $\mu$ F, 10%, 16 V	Murata/GRM155R61C333KA01D, AVX Corp./0402YD333KAT2A
62	1	C707	Capacitor, ceramic, X7R, 0402	1500 pF, 50 V	Panasonic/ECJ-0EB1H152K
63	1	C722	Capacitor, ceramic, X5R, 0402	0.22 $\mu$ F, 6.3 V	Panasonic/ECJ-0EB0J224K
64	5	CR101, CR102, CR104, CR105, CR106	Rectifier SIL	2 A, 50 V, DO-214AA	Micro Commercial Components Corp./S2A-TP
65	1	CR103	Surface-mount chip LED, 0603	Green	Panasonic/LNJ308G8TRA
66	1	CR601	Schottky diode	20 V <sub>BR</sub> , 1.2 pF, SOT-23	Avago Technologies/HSMS-2812BLK
67	3	CR701, CR801, CR802	LED, thin, diff., 0805, SMD	635 nm, red	Lumex/SML-LXT0805IW-TR
68	12	E101, E102, E103, E105, E107, E109, E110, E111, E112, E113, E114, E115	Bead core, 0805, SMD	4 A, 100 MHz	Panasonic/EXC-ML20A390U
69	1	F101	Polyswitch, 1812, reset fuse, SMD	1.6 A	Tyco Electronics/MINISMD160F-2
70	1	FL101	Filter EMI	50 m $\Omega$ , 15 A	Murata/BNX016-01
71	1	J201	Square post header	0.25" (0.64 mm), 0.100" (2.54 mm) centerline	Samtec/TSW-103-08-G-D

Item	Qty	Reference Designator	Description	Value	Manufacturer/Part No.
72	4	J203, J402, J501, J602	CONN-PCB	SMA, ST edge mount	Emerson Network Power Connectivity Solutions/142-0711-821, Samtec/SMA-J-P-H-ST-EM1
73	1	J205	CONN-PCB header	4P double row	Samtec/TSW-102-08-G-D
74	2	J301, J701	CONN-PCB header	8-pin double row	Samtec/TSW-104-08-T-D
75	1	J302	CONN-PCB header	ST male, 9-pin	Samtec/TSW-103-08-G-T
76	3	J403, J503, J605	CONN-PCB header	2 position, single row	Samtec/TSW-102-08-G-S
77	1	J404	CONN-PCB header	ST 10P	Samtec/TSW-105-08-G-D
78	2	JP101, JP103	Resistor, 0805, SMD	0.0 $\Omega$ , 1/8 W, 5%	Panasonic/ERJ-6GEY0R00V
79	3	JP503, L402, L501	Resistor, 0603, SMD	0 $\Omega$ , 1/10 W, 5%	Rohm Semiconductor/MCR03EZPJ000, Panasonic/ERJ-3GEY0R00V
80	4	L403, L404, L503, L504	Resistor, 0603, SMD	0.0 $\Omega$ , 1/10 W	Panasonic/ERJ-3GEY0R00V
81	1	P101	CONN power jack	2.1 mm $\times$ 5.5 mm, HI CUR	CUI/PJ-002AH-SMT
82	2	P102, P103	CONN-PCB header	6 position	Wieland/Z5.531.3625.0
83	3	P901, P902, P903	CONN_PCB RA connector	60 pin	Tyco Electronics/6469169-1
84	1	R101	Resistor, 0402, SMD	300 $\Omega$ , 1/16 W, 1%	Rohm Semiconductor/ MCR01MZPF3000, Panasonic/ERJ-2GEJ301X
85	1	R102	Resistor, 0402, SMD	147 k $\Omega$ , 1/10 W, 1%	Panasonic/ERJ-2RKF1473X
86	1	R103	Resistor, 0402, SMD	28.0 k $\Omega$ , 1/10 W, 1%	Panasonic/ERJ-2RKF2802X
87	1	R104	Resistor, 0402, SMD	10.0 $\Omega$ , 1/10 W, 1%	Panasonic/ERJ-2RKF10R0X
88	2	R112, R114	Resistor, 0402, SMD	18.7 k $\Omega$ , 1/10 W, 1%	Panasonic/ERJ-2RKF1872X
89	2	R113, R115	Resistor, 0402, SMD	15.0 k $\Omega$ , 1/10 W, 1%	Panasonic/ERJ-2RKF1502X
90	8	R206, R208, R209, R309, R316, R317, R801, R802	Resistor, 0402, SMD	10.0 k $\Omega$ , 1/16 W, 1%	Yageo/RC0402FR-0710KL, Panasonic/ERJ-2RKF1002X
91	2	R207, R733	Resistor, 0402, SMD	57.6 $\Omega$ , 1/16 W, 1%	Panasonic/ERJ-2RKF57R6X
92	13	R121, R123, R310, R311, R312, R422, R522, R614, R704, R705, R706, R707, R709	Resistor, 0402, SMD	1.00 k $\Omega$ , 1/16 W, 1%	Yageo/RC0402FR-071KL, Panasonic/ERJ-2RKF1001X
93	5	R105, R106, R313, R314, R315	Resistor, 0402, SMD	100 k $\Omega$ , 1/16 W, 1%	Rohm Semiconductor/ MCR01MZPF1003, Panasonic/ERJ-2RKF1003X
94	5	R403, R404, R503, R504, R741	Resistor, 0402, SMD	33 $\Omega$ , 1/10,W, 5%	Rohm Semiconductor/ MCR01MZPJ330, Panasonic/ERJ-2GEJ330X
95	4	R408, R409, R508, R509	Resistor, 0402, SMD	33 $\Omega$ , 1/10,W, 5%	Panasonic/ERJ-2GEJ330X
96	1	R602	Resistor, 0603, SMD	57.6 $\Omega$ , 1/10 W, 1%	Panasonic/ERJ-3EKF57R6V
97	1	R710	Resistor, 0402, SMD	4.12 k $\Omega$ , 1/16 W, 1%	Vishay/CRCW04024K12FKED, Panasonic/ERJ-2RKF4121X
98	1	R711	Resistor, 0402, SMD	5.11 k $\Omega$ , 1/16 W, 1%	Vishay/CRCW04025K11FKED, Panasonic/ERJ-2RKF5111X
99	8	R714, R716, R725, R730, R738, R739, R805, R806	Resistor, 0402, SMD	200 $\Omega$ , 1/10 W, 1%	Panasonic/ERJ-2RKF2000X
100	2	R726, R740	Resistor, 0402, SMD	100 $\Omega$ , 1/10 W, 5%	Panasonic/ERJ-2GEJ101X
101	2	R734, R736	Resistor, 0402, SMD	130 $\Omega$ , 1/16 W, 1%	Vishay/CRCW0402130RFKED, Panasonic/ERJ-2RKF1300X
102	2	R735, R737	Resistor , 0402, SMD	82.5 $\Omega$ , 1/16 W, 1%	Panasonic/ERJ-2RKF82R5X

Item	Qty	Reference Designator	Description	Value	Manufacturer/Part No.
103	9	RN801, RN802, RN803, RN804, RN805, RN806, RN807, RN808, RN809	Resistor array	22 $\Omega$ , 8 term, SMD	CTS Resistor Products/ 742C083220JPTR
104	5	T401, T402, T501, T502, T602	RF 1:1 transmission line transformer	6-pin special	M/A-COM/MABA-007159-000000
105	3	U101, U104, U105	Low dropout, CMOS linear regulator	1 A	Analog Devices/ADP1708ARDZ-R7
106	2	U102, U106	Low dropout, CMOS linear regulator	1 A	Analog Devices/ADP1706ARDZ-3.3-R7
107	1	U103	Low dropout, CMOS linear regulator	1 A	Analog Devices/ADP1706ARDZ-1.8-R7
108	1	U201	DUT		Analog Devices/DUT
109	1	U301	TinyLogic UHS dual buffer (open drain outputs)		Fairchild Semiconductor/ NC7WZ07P6X
110	3	U302, U703, U803	TinyLogic UHS dual buffer		Fairchild Semiconductor/ NC7WZ16P6X
111	1	U401	Ultralow distortion IF VGA		Analog Devices/AD8375ACPZ
112	1	U501	3.3 GHz ultralow distortion RF/IF differential amplifier		Analog Devices/ADL5562_PRELIM
113	1	U701	12-output clock generator with integrated 1.6 GHz VCO		Analog Devices/AD9517-4BCPZ
114	2	U801, U802	Low voltage 20-bit buffer/line driver with 3.6 V tolerant inputs and outputs and 26 $\Omega$ series resistors in the outputs		Fairchild Semiconductor/ 74VCX162827MTDX
115	1	VR101	Configurable, dual 2 A/single 4 A, synchronous step-down dc-to-dc regulator		Analog Devices/ADP2114_PRELIM
116	1	Y601	ACMOS/LSTTL compatible surface-mount clock OSC		Valpey Fisher/VFAC3BHL-XXMHZ

<sup>1</sup> Do not install.

Table 4. AD9268 Family BOM

Item	Qty	Reference Designator	Description	Value	Manufacturer/Part No.
1	1	Not applicable	PCBZ		
2	9	C101, C132, C133, C134, C135, C136, C145, C419, C514	Capacitor, ceramic NP0	10 $\mu$ F	Panasonic/ECJ-2FB0J106M
3	12	C102, C103, C104, C106, C124, C126, C127, C128, C129, C130, C144, C146	Capacitor, 0603, X5R	4.7 $\mu$ F	Panasonic/ECJ-1VB0J475M
4	7	C105, C117, C119, C121, C123, C125, C143	Capacitor, ceramic, multilayer, X7R, 0402	10,000 pF	Panasonic/ECJ-0EB1E103K
5	68	C116, C118, C120, C122, C149, C150, C151, C152, C153, C154, C204, C206, C207, C208, C209, C211, C301, C302, C403, C404, C405, C406, C407, C417, C418, C420, C426, C503, C504, C505, C506, C507, C515, C516, C523, C601, C602, C603, C606, C607, C609, C701, C702, C710, C711, C712, C713, C714, C715, C716, C717, C718, C719, C720, C721, C723, C724, C730, C731, C801, C802, C803, C804, C805, C806, C807, C808, C809	Capacitor, ceramic, 0402	0.1 $\mu$ F	Panasonic/ECJ-0EX1C104K
6	6	C138, C139, C141, C142, C147, C148	Capacitor, ceramic, chip	22 $\mu$ F	Murata/ GRM21BR60J226ME39L
7	3	C107, C203, C205	Capacitor, ceramic	1 $\mu$ F	Panasonic/ECJ-0EF0J105Z

Item	Qty	Reference Designator	Description	Value	Manufacturer/Part No.
8	27	C401, C402, C502, JP403, R203, R301, R302, R303, R304, R424, R425, R524, R525, R526, R606, R609, R610, R611, R612, R708, R715, R723, R727, R728, R729, R803, R804	Res film, SMD, 0402	0 Ω	Panasonic/ERJ-2GE0R00X
9	1	C604	Capacitor, ceramic	1000 pF	Panasonic/EJU-E1E102KBQ
10	1	C705	Capacitor, ceramic, multilayer, X7R, 0402	1800 pF	Panasonic/ECJ-0EB1E182K
11	1	C706	Capacitor, ceramic	0.033 μF	Panasonic/ 0402YD333KAT2A
12	1	C707	Capacitor, ceramic, 0402	1500 pF	Panasonic/ECJ-0EB1H152K
13	1	C722	Capacitor, ceramic	0.22 μF	Panasonic/ECJ-0EB0J224K
14	5	CR101, CR102, CR104, CR105, CR106	Diode recovery rectifier	S2A-TP	Micro Commercial Components Corp./S2A-TP
15	1	CR103	LED green, surface mount	LNJ308G8TRA (green)	Panasonic/LNJ308G8TRA
16	1	CR601	Diode, Schottky, dual series	HSMS-2812BLK	Avago Technologies/ HSMS-2812BLK
17	3	CR701, CR801, CR802	LED red, surface mount	SML-LXT0805IW-TR	Lumex/SML-LXT0805IW-TR
18	12	E101, E102, E103, E105, E107, E109, E110, E111, E112, E113, E114, E115	Inductor ferrite bead	100 MHz	Panasonic/ EXC-ML20A390U
19	1	F101	Fuse, polyswitch, PTC device	1.6 A	Tyco Electronics/ MINISMDC160F-2
20	1	FL101	Filter noise suppression, LC-combined type	BNX016-01	Murata/BNX016-01
21	1	J201	Connector-PCB, Berg, header, double STR, male, 6 pos	TSW-103-08-G-D	Samtec/TSW-103-08-G-D
22	4	J203, J402, J501, J602	Connector-PCB, SMA, ST edge mount	SMA-J-P-X-ST-EM1	Samtec/SMA-J-P-X-ST-EM1
23	1	J205	Connector-PCB, header, 4 pos, ST	TSW-102-08-G-D	Samtec/TSW-102-08-G-D
24	2	J301, J701	Connector-PCB, header, 8 pos, double row	TSW-104-08-T-D	Samtec/TSW-104-08-T-D
25	1	J302	Connector-PCB, header, ST male, 9 pos	TSW-103-08-G-T	Samtec/TSW-103-08-G-T
26	3	J403, J503, J605	Connector-PCB, header, 2 pos	TSW-102-08-G-S	Samtec/TSW-102-08-G-S
27	1	J404	Connector-PCB, header, ST, 10 pos	TSW-105-08-G-D	Samtec/TSW-105-08-G-D
28	2	JP101, JP103	Res jumper, SMD, 0805 (SHRT)	0 Ω	Panasonic/ERJ-6GEY0R00V
29	3	JP503, L402, L501	Res film, SMD, 0603	0 Ω	Panasonic/ERJ-3GEY0R00V
30	4	L403, L404, L503, L504	Inductor, ferrite bead	10 Ω @ 100 MHz	Murata/BLM18BA100SN1
31	1	P101	Connector-PCB, power jack, surface mount	PJ-002AH-SMT	CUI, Inc./PJ-002AH-SMT
32	2	P102, P103	Connector-PCB, header, 6 pos	Z5.531.3625.0	Wieland/Z5.531.3625.0
33	3	P901, P902, P903	Connector-PCB, 60-pin, RA connector	6469169-1	Tyco Electronics/6469169-1
34	1	R101	Res film, SMD, 0402	300 Ω	Panasonic/ERJ-2GEJ301X
35	1	R102	Res prec, thick film, chip, R0402	147 kΩ	Panasonic/ERJ-2RKF1473X
36	1	R103	Res prec, thick film, chip, R0402	28 kΩ	Panasonic/ERJ-2RKF2802X
37	1	R104	Res prec, thick film, chip, R0402	10 Ω	Panasonic/ERJ-2RKF10R0X
38	2	R112, R114	Res prec, thick film, chip, R0402	18.7 kΩ	Panasonic/ERJ-2RKF1872X

Item	Qty	Reference Designator	Description	Value	Manufacturer/Part No.
39	2	R113, R115	Res chip, SMD, 0402	15 kΩ	Panasonic/ERJ-2RKF1502X
40	8	R206, R208, R209, R309, R316, R317, R801, R802	Res prec, thick, film chip, R0402	10 kΩ	Panasonic/ERJ-2RKF1002X
41	2	R207, R733	Res prec, thick, film chip, R0402	57.6 Ω	Panasonic/ERJ-2RKF57R6X
42	13	R121, R123, R310, R311, R312, R422, R522, R614, R704, R705, R706, R707, R709	Res prec, thick, film chip, R0402	1.00 kΩ	Panasonic/ERJ-2RKF1001X
43	5	R105, R106, R313, R314, R315	Res prec, thick, film chip, R0402	100 kΩ	Panasonic/ERJ-2RKF1003X
44	5	R403, R404, R503, R504, R741	Res film, SMD, 0402	33 Ω	Panasonic/ERJ-2GEJ330X
	4	R408, R409, R508, R509	Res film, SMD 0402	66.5 Ω	Panasonic/ERJ-2RKF66R5X
46	1	R602	Res prec, thick, film chip, R0603	57.6 Ω	Panasonic/ERJ-3EKF57R6V
47	1	R710	Res prec, thick, film chip, R0402	4.12 kΩ	Panasonic/ERJ-2RKF4121X
48	1	R711	Res prec, thick, film chip, R0402	5.11 kΩ	Panasonic/ERJ-2RKF5111X
49	8	R714, R716, R725, R730, R738, R739, R805, R806	Res prec, thick, film chip, R0402	200 Ω	Panasonic/ERJ-2RKF2000X
50	2	R726, R740	Res film, SMD 0402	100 Ω	Panasonic/ERJ-2GEJ101X
51	2	R734, R736	Res prec, thick, film chip, R0402	130 Ω	Panasonic/ERJ-2RKF1300X
52	2	R735, R737	Res prec, thick, film chip, R0402	82.5 Ω	Panasonic/ERJ-2RKF82R5X
53	9	RN801, RN802, RN803, RN804, RN805, RN806, RN807, RN808, RN809	Res NTWRK, 8-pin/4 res, surface mount	22 Ω	CTS/742C083220JCT
54	5	T401, T402, T501, T502, T602	XFMR RF 1:1 (6-pin special)	MABA-007159-000000	M/A-Com/ MABA-007159-000000
55	3	U101, U104, U105	IC-ADI, low dropout, CMOS line regulator	ADP1708ARDZ-R7	Analog Devices, Inc./ ADP1708ARDZ-R7
56	2	U102, U106	IC-ADI, low dropout, CMOS line regulator	ADP1706ARDZ-3.3-R7	Analog Devices, Inc./ ADP1706ARDZ-3.3-R7
57	1	U103	IC-ADI, low dropout, CMOS line regulator	ADP1706ARDZ-1.8-R7	Analog Devices, Inc./ ADP1706ARDZ-1.8-R7
58	1	U201	Generic LFCSP64-9X9-9PAD1_8X1_8 footprint	AD9268BCPZ-125 or AD9258BCPZ-125	Analog Devices, Inc./ AD9268BCPZ-125 or AD9258BCPZ-125
59	1	U301	IC TinyLogic®, UHS dual buffer	NC7WZ07P6X	Fairchild Semiconductor/ NC7WZ07P6X
60	3	U302, U703, U803	IC TinyLogic, UHS dual buffer	NC7WZ16P6X	Fairchild Semiconductor/ NC7WZ16P6X
61	1	U401	IC ultralow, distortion IF VGA	AD8375ACPZ	Analog Devices, Inc./ AD8375ACPZ
62	1	U501	IC 2.6 GHz, ultralow distortion, RF/IF diff amp	ADL5562_PRELIM	Analog Devices, Inc./ ADL5562
63	1	U701	IC-ADI 12-output CLK generator with integrated 1.6 GHz VCO	AD9517-4BCPZ	Analog Devices, Inc./ AD9517-4BCPZ
64	2	U801, U802	IC-TTL, low voltage, 20-bit buffer	74VCX162827MTDX	Fairchild Semiconductor/ 74VCX162827MTDX
65	1	VR101	IC ADI dual configurable, synchronous, stepdown, dc-to-dc regulator	ADP2114_PRELIM	Analog Devices, Inc./ ADP2114
66	1	Y601-125 for -125 model U201	IC clock OSC AC MOS/LSTTL compatible	125 MHz	Valpey Fisher/ VFAC3BHL-125MHZ
67	1	Y601-105 for -105 model U201	IC clock OSC AC MOS/LSTTL compatible	105 MHz	Valpey Fisher/ VFAC3BHL-105MHZ

Item	Qty	Reference Designator	Description	Value	Manufacturer/Part No.
68	1	Y601-80 for -80 model U201	IC clock OSC AC MOS/ LSTTL compatible	80 MHz	Valpey Fisher/ VFAC3BHL-80MHZ
69 <sup>1</sup>		C108, C109	Capacitor, ceramic, multilayer, X7R 0402	10,000 pF	Panasonic/ECJ-0EB1E103K
70 <sup>1</sup>		C110	Capacitor, ceramic	2200 pF	Phycomp (Yageo)/ CC0402KRX7R9BB222
71 <sup>1</sup>		C111, C113, C519	Capacitor, ceramic, mono cer, C0G, 0402	100 pF	Murata/ GRM1555C1H101JD01D
72 <sup>1</sup>		C112	Capacitor, ceramic, 0402	1500 pF	Panasonic/ECJ-0EB1H152K
73 <sup>1</sup>		C137, C140	Capacitor, cer, SMD 0603	N/A	N/A
74 <sup>1</sup>		C408, C409, C410, C411, C508, C509, C510, C511	Capacitor, ceramic, NP0	5 pF	Panasonic/ECJ-E1H050CCQ
75 <sup>1</sup>		C201, C202, C412, C413, C414, C415, C416, C421, C427, C512, C513, C521, C522, C610, C703, C704, C708, C709	Capacitor, ceramic, 0402	0.1 μF	Panasonic/ECJ-0EX1C104K
76 <sup>1</sup>		C422, C423	Capacitor, ceramic, multilayer, X7R, 0402	1200 pF	Panasonic/ECJ-0EB1E122K
77 <sup>1</sup>		C424	Capacitor, ceramic	2.7 pF	Samsung/CL05C2R7CBNC
78 <sup>1</sup>		C425	Capacitor, mono, ceramic, C0G, 0402	20 pF	Murata/ GRM1555C1H200JZ01D
79 <sup>1</sup>		C517, C518	Capacitor, ceramic	1000 pF	Panasonic/ECU-E1E102KBQ
80 <sup>1</sup>		C520	Capacitor, ceramic	39 pF	Phycomp (Yageo)/ 0402CG390J9B200
81 <sup>1</sup>		E104, E106, E108, E116, E117, E118, E119	Inductor ferrite bead	100 MHz	Panasonic/EXC-ML20A390U
82 <sup>1</sup>		J401, J502, J601, J702, J703, J704	Connector-PCB SMA, ST edge mount	SMA-J-P-X-ST-EM1	Samtec/SMA-J-P-X-ST-EM1
83 <sup>1</sup>		JP102, JP104	Resistor jumper, SMD, 0805 (SHRT)	0 Ω	Panasonic/ERJ-GEY0R00V
84 <sup>1</sup>		L101, L102	Inductor sm	2.2 μH	TOKO/FDV0630-2R2M
85 <sup>1</sup>		L401, L502	Res film, SMD 0603	0 Ω	Panasonic/ERJ-3GEY0R00V
86 <sup>1</sup>		L405, L505	Inductor SM	100 nH	Coilcraft/0603CS-R10XGLU
87 <sup>1</sup>		L406, L407	Inductor SM	1 μH	Coilcraft/0603LS-102XGLB
88 <sup>1</sup>		L408, L409, L410, L411	Inductor SM	270 nH	Coilcraft/0603CS-R27XGLW
89 <sup>1</sup>		L508, L509	Chip inductor	15 nH	Coilcraft/0603CS-15NXGLU
90 <sup>1</sup>		L510, L520	Chip inductor	36 nH	Coilcraft/0603CS-36NXGLU
91 <sup>1</sup>		L521, L522	Inductor SM	82 nH	Coilcraft/0603CS-82NXGLU
92 <sup>1</sup>		R107	Resistor, chip, SMD 0402	27 kΩ	Panasonic/ERJ-2RKF2702X
93 <sup>1</sup>		R108	Res prec, thick film chip, R0402	10.5 kΩ	Panasonic/ERJ-2RKF1052X
94 <sup>1</sup>		R109	Resistor, chip, SMD 0402	4.75 kΩ	Panasonic/ERJ-2RKF4751X
95 <sup>1</sup>		R110, R111	Resistor, chip, SMD 0402	15 kΩ	Panasonic/ERJ-2RKF1502X
96 <sup>1</sup>		R116, R117	Resistor, chip, SMD 0603	N/A	N/A
97 <sup>1</sup>		R118	Res film, SMD 0402	13 kΩ	Yageo Corp./ 9C04021A1302FLHF3
98 <sup>1</sup>		C501, JP401, JP402, JP501, JP502, R120, R122, R124, R125, R126, R127, R305, R306, R307, R308, R405, R407, R410, R411, R413, R414, R415, R423, R505, R507, R510, R511, R514, R515, R516, R517, R519, R520, R521, R603, R604, R605, R607, R608, R721, R722, R731, R732	Res film, SMD 0402	0 Ω	Panasonic/ERJ-2GE0R00X
99 <sup>1</sup>		R518	Res prec, thick film chip, R0402	1.00 kΩ	Panasonic/ERJ-2RKF1001X
100 <sup>1</sup>		R201	Res prec, thick film chip, R0402	2 kΩ	Panasonic/ERJ-2RKF2001X
101 <sup>1</sup>		R202	Res VAR 3/8" SQ top adj	10 kΩ	Bourns, Inc./3299W-1-103
102 <sup>1</sup>		R204, R205	Resistor, chip, SMD 0402	N/A	N/A

Item	Qty	Reference Designator	Description	Value	Manufacturer/Part No.
103 <sup>1</sup>		R401, R402, R501, R502, R601	Res prec, thick film chip, R0603	57.6 Ω	Panasonic/ERJ-3EKF57R6V
104 <sup>1</sup>		R406, R506, R719, R720	Res prec, thick film chip, R0402	49.9 Ω	Panasonic/ERJ-2RKF49R9X
105 <sup>1</sup>		R412	Res prec, thick film chip, R0402	130 Ω	Panasonic/ERJ-2RKF1300X
106 <sup>1</sup>		R416	Res film, SMD 0402	300 Ω	Panasonic/ERJ-2GEJ301X
107 <sup>1</sup>		R417, R418, R419, R420, R421	Res prec, thick film chip, R0402	10 kΩ	Panasonic/ERJ-2RKF1002X
108 <sup>1</sup>		R512, R513	Res prec, thick film chip, R0402	40.2 Ω	Panasonic/ERJ-2RKF40R2X
109 <sup>1</sup>		R613	Res film, SMD, 0402	100 Ω	Panasonic/ERJ-2GEJ101X
110 <sup>1</sup>		T403, T503	XFMR RF	ADT1-1WT	Mini-Circuits/ADT1-1WT
111 <sup>1</sup>		T404	XFMR RF	TC3-1T+	Mini-Circuits/TC3-1T+
112 <sup>1</sup>		T505	XFMR RF 1:1 (6-pin special)	MABA-007159-000000	M/A-COM/ MABA-007159-000000
113 <sup>1</sup>		T601	XFMR RF	ADT1-1WT+	Mini-Circuits/ADT1-1WT+
114 <sup>1</sup>		TP101, TP102, TP402, TP601, TP801, TP802	Connector-PCB TST PNT BLK	Black	Components Corp./ TP-104-01-00
115 <sup>1</sup>		TP9, TP401, TP701, TP702, TP703, TP704, TP705	Connector-PCB TST PNT WHT	White	Components Corp./ TP-104-01-09
116 <sup>1</sup>		U702	IC-ADI ultrafast, SiGe ECL clock/data buffers	ADCLK905BCPZ-WP	Analog Devices, Inc./ ADCLK905BCPZ-WP
117 <sup>1</sup>		CR201	IC-ADI 1.2 V micropower prec. shunt voltage ref.	AD1580ARTZ	Analog Devices, Inc./ AD1580ARTZ
118 <sup>1</sup>		U202	IC-ADI single-supply, rail-to-rail, low power FET, input op amp	AD822BRZ	Analog Devices, Inc./ AD822BRZ

<sup>1</sup> Do not install.

Table 5. AD9269 Family BOM

Item	Qty	Reference Designator	Description	Value	Manufacturer/Part No.
1	1	Not applicable	PCBZ		
2	9	C101, C132, C133, C134, C135, C136, C145, C419, C514	Capacitor, ceramic, NP0	10 μF	Panasonic/ECJ-2FB0J106M
3	12	C102, C103, C104, C106, C124, C126, C127, C128, C129, C130, C144, C146	Capacitor, 0603, X5R	4.7 μF	Panasonic/ECJ-1VB0J475M
4	7	C105, C117, C119, C121, C123, C125, C143	Capacitor, ceramic, multilayer, X7R, 0402	10,000 pF	Panasonic/ECJ-0EB1E103K
5	68	C116, C118, C120, C122, C149, C150, C151, C152, C153, C154, C204, C206, C207, C208, C209, C211, C301, C302, C403, C404, C405, C406, C407, C417, C418, C420, C426, C503, C504, C505, C506, C507, C515, C516, C523, C602, C603, C606, C607, C609, C610, C701, C702, C710, C711, C712, C713, C714, C715, C716, C717, C718, C719, C720, C721, C723, C724, C730, C731, C801, C802, C803, C804, C805, C806, C807, C808, C809	Capacitor, ceramic, 0402	0.1 μF	Panasonic/ECJ-0EX1C104K
6	6	C138, C139, C141, C142, C147, C148	Capacitor, ceramic, chip	22 μF	Murata/ GRM21BR60J226ME39L
7	3	C107, C203, C205	Capacitor, ceramic	1 μF	Panasonic/ECJ-0EF0J105Z
8	28	C401, C402, C502, C604, JP403, R203, R301, R302, R303, R304, R424, R425, R524, R525, R526, R606, R609, R610, R611, R612, R708, R715, R723, R727, R728, R729, R803, R804	Res film, SMD, 0402	0 Ω	Panasonic/ERJ-2GE0R00X

Item	Qty	Reference Designator	Description	Value	Manufacturer/Part No.
9	2	C410, C510	Capacitor, ceramic NP0	22 pF	Panasonic/ECU-E1H220J
10	1	C705	Capacitor, ceramic, multilayer, X7R, 0402	1800 pF	Panasonic/ECJ-0EB1E182K
11	1	C706	Capacitor, ceramic	0.033 $\mu$ F	Panasonic/0402YD333KAT2A
12	1	C707	Capacitor, ceramic, 0402	1500 pF	Panasonic/ECJ-0EB1H152K
13	1	C722	Capacitor, ceramic	0.22 $\mu$ F	Panasonic/ECJ-0EB0J224K
14	5	CR101, CR102, CR104, CR105, CR106	Diode recovery rectifier	S2A-TP	Micro Commercial Components Corp./S2A-TP
15	1	CR103	LED green, surface mount	LNJ308G8TRA (green)	Panasonic/LNJ308G8TRA
16	1	CR601	Diode, Schottky, dual series	HSMS-2812BLK	Avago Technologies/HSMS-2812BLK
17	3	CR701, CR801, CR802	LED red, surface mount	SML-LXT0805IW-TR	Lumex/SML-LXT0805IW-TR
18	12	E101, E102, E103, E105, E107, E109, E110, E111, E112, E113, E114, E115	Inductor ferrite bead	100 MHz	Panasonic/EXC-ML20A390U
19	1	F101	Fuse, polyswitch, PTC device	1.6 A	Tyco Electronics/MINISMDC160F-2
20	1	FL101	Filter noise, suppression, LC-combined type	BNX016-01	Murata/BNX016-01
21	1	J201	Connector-PCB, Berg header, double STR, male 6 pos	TSW-103-08-G-D	Samtec/TSW-103-08-G-D
22	4	J203, J402, J501, J602	Connector-PCB, SMA, ST edge mount	SMA-J-P-X-ST-EM1	Samtec/SMA-J-P-X-ST-EM1
23	1	J205	Connector-PCB, header, 4 pos ST	TSW-102-08-G-D	Samtec/TSW-102-08-G-D
24	2	J301, J701	Connector-PCB, header, 8 pos double row	TSW-104-08-T-D	Samtec/TSW-104-08-T-D
25	1	J302	Connector-PCB, header, ST male, 9 pos	TSW-103-08-G-T	Samtec/TSW-103-08-G-T
26	3	J403, J503, J605	Connector-PCB, header 2 pos	TSW-102-08-G-S	Samtec/TSW-102-08-G-S
27	1	J404	Connector-PCB, header, ST 10 pos	TSW-105-08-G-D	Samtec/TSW-105-08-G-D
28	2	JP101, JP103	Res jumper, SMD, 0805 (SHRT)	0 $\Omega$	Panasonic/ERJ-6GEY0R00V
29	7	JP503, L402, L403, L404, L501, L503, L504	Res film, SMD, 0603	0 $\Omega$	Panasonic/ERJ-3GEY0R00V
30	1	P101	Connector-PCB, power jack, surface mount	PJ-002AH-SMT	CUI, Inc./PJ-002AH-SMT
31	2	P102, P103	Connector-PCB, header, 6 pos	Z5.531.3625.0	Wieland/Z5.531.3625.0
32	3	P901, P902, P903	Connector-PCB, 60-pin, RA connector	6469169-1	Tyco Electronics/6469169-1
33	1	R101	Res film, SMD, 0402	300 $\Omega$	Panasonic/ERJ-2GEJ301X
34	1	R102	Res prec, thick film chip, R0402	147 k $\Omega$	Panasonic/ERJ-2RKF1473X
35	1	R103	Res prec, thick film chip, R0402	28 k $\Omega$	Panasonic/ERJ-2RKF2802X
36	1	R104	Res prec, thick film chip, R0402	10 $\Omega$	Panasonic/ERJ-2RKF10R0X
37	2	R112, R114	Res prec, thick film chip, R0402	18.7 k $\Omega$	Panasonic/ERJ-2RKF1872X
38	2	R113, R115	Res chip, SMD, 0402	15 k $\Omega$	Panasonic/ERJ-2RKF1502X
39	8	R206, R208, R209, R309, R316, R317, R801, R802	Res prec, thick film chip, R0402	10 k $\Omega$	Panasonic/ERJ-2RKF1002X
40	2	R207, R733	Res prec, thick film chip, R0402	57.6 $\Omega$	Panasonic/ERJ-2RKF57R6X

Item	Qty	Reference Designator	Description	Value	Manufacturer/Part No.
41	13	R121, R123, R310, R311, R312, R422, R522, R614, R704, R705, R706, R707, R709	Res prec, thick film chip, R0402	1.00 k $\Omega$	Panasonic/ERJ-2RKF1001X
42	5	R105, R106, R313, R314, R315	Res prec, thick film chip, R0402	100 k $\Omega$	Panasonic/ERJ-2RKF1003X
43	9	R403, R404, R408, R409, R503, R504, R508, R509, R741	Res film, SMD, 0402	33 $\Omega$	Panasonic/ERJ-2GEJ330X
44	1	R602	Res prec, thick film chip, R0603	57.6 $\Omega$	Panasonic/ERJ-3EKF57R6V
	1	R710	Res prec, thick film chip, R0402	4.12 k $\Omega$	Panasonic/ERJ-2RKF4121X
46	1	R711	Res prec, thick film chip, R0402	5.11 k $\Omega$	Panasonic/ERJ-2RKF5111X
47	8	R714, R716, R725, R730, R738, R739, R805, R806	Res prec, thick film chip, R0402	200 $\Omega$	Panasonic/ERJ-2RKF2000X
48	2	R726, R740	Res film, SMD, 0402	100 $\Omega$	Panasonic/ERJ-2GEJ101X
49	2	R734, R736	Res prec, thick film chip, R0402	130 $\Omega$	Panasonic/ERJ-2RKF1300X
50	2	R735, R737	Res prec, thick film chip, R0402	82.5 $\Omega$	Panasonic/ERJ-2RKF82R5X
51	9	RN801, RN802, RN803, RN804, RN805, RN806, RN807, RN808, RN809	Res network, 8-pin/4 res, surface mount	220 $\Omega$	CTS/742C083221JCT
52	4	T401, T402, T501, T502,	XFMR RF 1:1 (6-pin special)	MABA-007159-000000	M/A-Com/ MABA-007159-000000
53	1	T601	XFMR RF	ADT1-1WT+	Mini-Circuits/ADT1-1WT+
54	3	U101, U104, U105	IC-ADI, low dropout, CMOS line regulator	ADP1708ARDZ-R7	Analog Devices, Inc./ ADP1708ARDZ-R7
55	2	U102, U106	IC-ADI, low dropout, CMOS line regulator	ADP1706ARDZ-3.3-R7	Analog Devices, Inc./ ADP1706ARDZ-3.3-R7
56	1	U103	IC-ADI, low dropout, CMOS line regulator	ADP1706ARDZ-1.8-R7	Analog Devices, Inc./ ADP1706ARDZ-1.8-R7
57	1	U201	Generic LFCSP64-9X9-9PAD1_8X1_8 footprint	AD9251BCPZ-xx, AD9231BCPZ-xx, AD9204BCPZ-xx, AD9269BCPZ-xx, or AD6659BCPZ-xx	Analog Devices, Inc./ AD9251BCPZ-xx, AD9231BCPZ-xx, AD9204BCPZ-xx, AD9269BCPZ-xx, or AD6659BCPZ-xx
58	1	U301	IC TinyLogic UHS, dual buffer	NC7WZ07P6X	Fairchild Semiconductor/ NC7WZ07P6X
59	3	U302, U703, U803	IC TinyLogic UHS dual buffer	NC7WZ16P6X	Fairchild Semiconductor/ NC7WZ16P6X
60	1	U401	IC ultralow, distortion IF VGA	AD8375ACPZ	Analog Devices, Inc./ AD8375ACPZ
61	1	U501	IC 2.6 GHz, ultralow distortion, RF/IF diff amp	ADL5562_PRELIM	Analog Devices, Inc./ ADL5562_PRELIM
62	1	U701	IC-ADI 12-output CLK generator with integrated 1.6 GHz VCO	AD9517-4BCPZ	Analog Devices, Inc./ AD9517-4BCPZ
63	2	U801, U802	IC-TTL, low voltage, 20-bit buffer	74VCX162827MTDX	Fairchild Semiconductor/ 74VCX162827MTDX
64	1	VR101	IC ADI dual configurable, synchronous, stepdown, dc-to-dc regulator	ADP2114_PRELIM	Analog Devices, Inc./ ADP2114_PRELIM
65	1	Y601-80 for -80 model U201	IC clock OSC, ACNOS/ LSTTL compatible	80 MHz	Valpey Fisher/ VFAC3BHL-80MHZ
66	1	Y601-65 for -65 model U201	IC clock OSC, ACNOS/ LSTTL compatible	65 MHz	Valpey Fisher/ VFAC3BHL-65MHZ
67	1	Y601-40 for -40 model U201	IC clock OSC, ACNOS/ LSTTL compatible	40 MHz	Valpey Fisher/ VFAC3BHL-40MHZ (

Item	Qty	Reference Designator	Description	Value	Manufacturer/Part No.
68	1	Y601-20 for -20 model U201	IC clock OSC, AC CMOS/ LSTTL compatible	20 MHz	Valpey Fisher/ VFAC3BHL-20MHZ
69 <sup>1</sup>		C108, C109	Capacitor, ceramic, multilayer, X7R 0402	10,000 pF	Panasonic/ECJ-0EB1E103K
70 <sup>1</sup>		C110	Capacitor, ceramic	2200 pF	Phy Comp (Yageo)/ CC0402KRX7R9BB222
71 <sup>1</sup>		C111, C113, C519	Capacitor, chip, mono, ceramic, C0G, 0402	100 pF	Murata/ GRM1555C1H101JD01D
72 <sup>1</sup>		C112	Capacitor, ceramic, 0402	1500 pF	Panasonic/ECJ-0EB1H152K
73 <sup>1</sup>		C137, C140	Capacitor, ceramic, SMD, 0603	N/A	N/A
74 <sup>1</sup>		C408, C409, C411, C508, C509, C511	Capacitor, ceramic, NP0	5 pF	Panasonic/ECJ-E1H050CCQ
75 <sup>1</sup>		C201, C202, C412, C413, C414, C415, C416, C421, C427, C512, C513, C521, C522, C601, C703, C704, C708, C709	Capacitor, ceramic, 0402	0.1 $\mu$ F	Panasonic/ECJ-0EX1C104K
76 <sup>1</sup>		C422, C423	Capacitor, ceramic, multilayer, X7R, 0402	1200 pF	Panasonic/ECJ-0EB1E122K
77 <sup>1</sup>		C424	Capacitor, ceramic	2.7 pF	Samsung/CL05C2R7CBNC
78 <sup>1</sup>		C425	Capacitor, mono, ceramic, C0G, 0402	20 pF	Murata/ GRM1555C1H200JZ01D
79 <sup>1</sup>		C517, C518	Capacitor, ceramic	1000 pF	Panasonic/ECU-E1E102KBQ
80 <sup>1</sup>		C520	Capacitor, ceramic	39 pF	Phy Comp (Yageo)/ 0402CG390J9B200
81 <sup>1</sup>		E104, E106, E108, E116, E117, E118, E119	Inductor ferrite bead	100 MHz	Panasonic/EXC-ML20A390U
82 <sup>1</sup>		J401, J502, J601, J702, J703, J704	Connector-PCB, SMA, ST edge mount	SMA-J-P-X-ST-EM1	Samtec/SMA-J-P-X-ST-EM1
83 <sup>1</sup>		JP102, JP104	Res jumper, SMD, 0805 (SHRT)	0 $\Omega$	Panasonic/ERJ-6EY0R00V
84 <sup>1</sup>		L101, L102	Inductor, SM	2.2 $\mu$ H	TOKO/FDV0630-2R2M
85 <sup>1</sup>		L401, L502	Res film, SMD, 0603	0 $\Omega$	Panasonic/ERJ-3GEY0R00V
86 <sup>1</sup>		L405, L505	Inductor, SM	100 nH	Coilcraft/0603CS-R10XGLU
87 <sup>1</sup>		L406, L407	Inductor, SM	1 $\mu$ H	Coilcraft/0603LS-102XGLB
88		L408, L409, L410, L411	Inductor, SM	270 nH	Coilcraft/0603CS-R27XGLW
89 <sup>1</sup>		L508, L509	Chip inductor	15 nH	Coilcraft/0603CS-15NXGLU
90 <sup>1</sup>		L510, L520	Chip inductor	36 nH	Coilcraft/0603CS-36NXGLU
91 <sup>1</sup>		L521, L522	Inductor, SM	82 nH	Coilcraft/0603CS-82NXGLU
92 <sup>1</sup>		R107	Res chip, SMD, 0402	27 k $\Omega$	Panasonic/ERJ-2RKF2702X
93 <sup>1</sup>		R108	Res prec, thick film chip, R0402	10.5 k $\Omega$	Panasonic/ERJ-2RKF1052X
94 <sup>1</sup>		R109	Res chip, SMD, 0402	4.75 k $\Omega$	Panasonic/ERJ-2RKF4751X
95 <sup>1</sup>		R110, R111	Res chip, SMD, 0402	15 k $\Omega$	Panasonic/ERJ-2RKF1502X
96 <sup>1</sup>		R116, R117	Res chip, SMD, 0603	N/A	N/A
97 <sup>1</sup>		R118	Res chip, SMD, 0402	13 k $\Omega$	Yageo/9C04021A1302FLHF3
98 <sup>1</sup>		C501, JP401, JP402, JP501, JP502, R120, R122, R124, R125, R126, R127, R305, R306, R307, R308, R405, R407, R410, R411, R413, R414, R415, R423, R505, R507, R510, R511, R514, R515, R516, R517, R519, R520, R521, R603, R604, R605, R607, R608, R721, R722, R731, R732	Res film, SMD, 0402	0 $\Omega$	Panasonic/ERJ-2GE0R00X
99 <sup>1</sup>		R518	Res prec, thick film, chip, R0402	1.00 k $\Omega$	Panasonic/ERJ-2RKF1001X
100 <sup>1</sup>		R201	Res prec, thick film, chip, R0402	2 k $\Omega$	Panasonic/ERJ-2RKF2001X
101 <sup>1</sup>		R202	Res VAR 3-/8-inch, SQ top adj	10 k $\Omega$	Bourns, Inc./3299W-1-103
102 <sup>1</sup>		R204, R205	Res chip, SMD, 0402	N/A	N/A

Item	Qty	Reference Designator	Description	Value	Manufacturer/Part No.
103 <sup>1</sup>		R401, R402, R501, R502, R601	Res prec, thick film, chip, R0603	57.6 $\Omega$	Panasonic/ERJ-3EKF57R6V
104 <sup>1</sup>		R406, R506, R719, R720	Res prec, thick film, chip, R0402	49.9 $\Omega$	Panasonic/ERJ-2RKF49R9X
105 <sup>1</sup>		R412	Res prec, thick film, chip, R0402	130 $\Omega$	Panasonic/ERJ-2RKF1300X
106 <sup>1</sup>		R416	Res film, SMD, 0402	300 $\Omega$	Panasonic/ERJ-2GEJ301X
107 <sup>1</sup>		R417, R418, R419, R420, R421	Res prec, thick film, chip, R0402	10 k $\Omega$	Panasonic/ERJ-2RKF1002X
108 <sup>1</sup>		R512, R513	Res prec, thick film, chip, R0402	40.2 $\Omega$	Panasonic/ERJ-2RKF40R2X
109 <sup>1</sup>		R613	Res film, SMD, 0402	100 $\Omega$	Panasonic/ERJ-2GEJ101X
110 <sup>1</sup>		T403, T503	XFMR RF	ADT1-1WT	Mini-Circuits/ADT1-1WT
111 <sup>1</sup>		T404	XFMR RF	TC3-1T+	Mini-Circuits/TC3-1T+
112 <sup>1</sup>		T505, T602	XFMR RF 1:1 (6-pin special)	MABA-007159-000000	M/A-Com/ MABA-007159-000000
113 <sup>1</sup>		TP101, TP102, TP402, TP601, TP801, TP802	Connector-PCB, TST PNT black	BLK	Components Corp./ TP-104-01-00
114 <sup>1</sup>		TP9, TP401, TP701, TP702, TP703, TP704, TP705	Connector-PCB, TST PNT white	WHT	Components Corp./ TP-104-01-09
115 <sup>1</sup>		U702	IC-ADI ultrafast, SIGe ECL clock/data buffers	ADCLK905BCPZ-WP	Analog Devices, Inc./ ADCLK905BCPZ-WP
116 <sup>1</sup>		CR201	IC-ADI 1.2 V micropower precision shunt voltage reference	AD1580ARTZ	Analog Devices, Inc./ AD1580ARTZ
117 <sup>1</sup>		U202	IC-ADI single-supply, rail-to-rail, low power FET, input op amp	AD822BRZ	Analog Devices, Inc./ AD822BRZ

<sup>1</sup> Do not install.

## NOTES

**ESD Caution**

**ESD (electrostatic discharge) sensitive device.** Charged devices and circuit boards can discharge without detection. Although this product features patented or proprietary protection circuitry, damage may occur on devices subjected to high energy ESD. Therefore, proper ESD precautions should be taken to avoid performance degradation or loss of functionality.

**Legal Terms and Conditions**

By using the evaluation board discussed herein (together with any tools, components documentation or support materials, the "Evaluation Board"), you are agreeing to be bound by the terms and conditions set forth below ("Agreement") unless you have purchased the Evaluation Board, in which case the Analog Devices Standard Terms and Conditions of Sale shall govern. Do not use the Evaluation Board until you have read and agreed to the Agreement. Your use of the Evaluation Board shall signify your acceptance of the Agreement. This Agreement is made by and between you ("Customer") and Analog Devices, Inc. ("ADI"), with its principal place of business at One Technology Way, Norwood, MA 02062, USA. Subject to the terms and conditions of the Agreement, ADI hereby grants to Customer a free, limited, personal, temporary, non-exclusive, non-sublicensable, non-transferable license to use the Evaluation Board FOR EVALUATION PURPOSES ONLY. Customer understands and agrees that the Evaluation Board is provided for the sole and exclusive purpose referenced above, and agrees not to use the Evaluation Board for any other purpose. Furthermore, the license granted is expressly made subject to the following additional limitations: Customer shall not (i) rent, lease, display, sell, transfer, assign, sublicense, or distribute the Evaluation Board; and (ii) permit any Third Party to access the Evaluation Board. As used herein, the term "Third Party" includes any entity other than ADI, Customer, their employees, affiliates and in-house consultants. The Evaluation Board is NOT sold to Customer; all rights not expressly granted herein, including ownership of the Evaluation Board, are reserved by ADI. CONFIDENTIALITY. This Agreement and the Evaluation Board shall all be considered the confidential and proprietary information of ADI. Customer may not disclose or transfer any portion of the Evaluation Board to any other party for any reason. Upon discontinuation of use of the Evaluation Board or termination of this Agreement, Customer agrees to promptly return the Evaluation Board to ADI. ADDITIONAL RESTRICTIONS. Customer may not disassemble, decompile or reverse engineer chips on the Evaluation Board. Customer shall inform ADI of any occurred damages or any modifications or alterations it makes to the Evaluation Board, including but not limited to soldering or any other activity that affects the material content of the Evaluation Board. Modifications to the Evaluation Board must comply with applicable law, including but not limited to the RoHS Directive. TERMINATION. ADI may terminate this Agreement at any time upon giving written notice to Customer. Customer agrees to return to ADI the Evaluation Board at that time. LIMITATION OF LIABILITY. THE EVALUATION BOARD PROVIDED HEREUNDER IS PROVIDED "AS IS" AND ADI MAKES NO WARRANTIES OR REPRESENTATIONS OF ANY KIND WITH RESPECT TO IT. ADI SPECIFICALLY DISCLAIMS ANY REPRESENTATIONS, ENDORSEMENTS, GUARANTEES, OR WARRANTIES, EXPRESS OR IMPLIED, RELATED TO THE EVALUATION BOARD INCLUDING, BUT NOT LIMITED TO, THE IMPLIED WARRANTY OF MERCHANTABILITY, TITLE, FITNESS FOR A PARTICULAR PURPOSE OR NON-INFRINGEMENT OF INTELLECTUAL PROPERTY RIGHTS. IN NO EVENT WILL ADI AND ITS LICENSORS BE LIABLE FOR ANY INCIDENTAL, SPECIAL, INDIRECT, OR CONSEQUENTIAL DAMAGES RESULTING FROM CUSTOMER'S POSSESSION OR USE OF THE EVALUATION BOARD, INCLUDING BUT NOT LIMITED TO LOST PROFITS, DELAY COSTS, LABOR COSTS OR LOSS OF GOODWILL. ADI'S TOTAL LIABILITY FROM ANY AND ALL CAUSES SHALL BE LIMITED TO THE AMOUNT OF ONE HUNDRED US DOLLARS (\$100.00). EXPORT. Customer agrees that it will not directly or indirectly export the Evaluation Board to another country, and that it will comply with all applicable United States federal laws and regulations relating to exports. GOVERNING LAW. This Agreement shall be governed by and construed in accordance with the substantive laws of the Commonwealth of Massachusetts (excluding conflict of law rules). Any legal action regarding this Agreement will be heard in the state or federal courts having jurisdiction in Suffolk County, Massachusetts, and Customer hereby submits to the personal jurisdiction and venue of such courts. The United Nations Convention on Contracts for the International Sale of Goods shall not apply to this Agreement and is expressly disclaimed.

## Looking for pricing, stock, or lifecycle information?

Click below to explore more details on WIN SOURCE:

 [View AD9628-125EBZ on WIN SOURCE](#)

 [Analog Devices Inc. Information](#)

## Optimize Your Supply Chain with WIN SOURCE Solutions

-  Global Sourcing Solution
-  Obsolete Management
-  Cost Control Management
-  Shortage Management
-  Alternative Solution
-  Excess Inventory Management