



**THE DATASHEET OF
VM801B50A-BK**



FTDI Chip

VM801B Datasheet

Embedded Video Engine Basic module

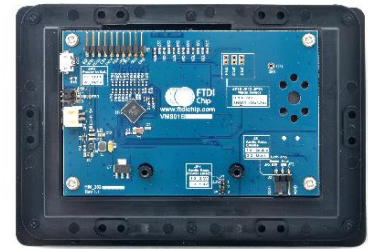

General Purpose Multi Media Controller

The VM801B is a development module for FTDI's FT801, which is used to develop and demonstrate the functionality of the FT801 Embedded Video Engine, EVE.

This module behaves as an SPI slave, and requires a SPI Master for proper micro-controller interfacing and system integration.

VM801B modules support 2 different LCD panel size options and are designed for industrial or commercial environments with precision fitted bezels in either black (-BK) or pearl (-PL).

- VM801B43A-xx is the 4.3" LCD
- VM801B50A-xx is the 5.0" LCD

The VM801B utilises the FTDI FT801 Embedded Video Engine, EVE. Graphic, audio and touch features of the FT801 chip can be accessed with the VM801B. For a full list of the FT801's features please see the FT801 datasheet. The VM801B has the following features:

- Ready to use LCD module.
- Integrated with capacitive multi-touch screen LCD panel
- Firmware compatible with VM800B module in default single touch mode.
- On board LCD backlight LED Driver
- On board audio power amplifier and micro speaker
- Flexible power supply. Powering the VM801B using either from a 2.1mm power jack , SPI master connector or via USB Micro-B port
- 5 V tolerant buffers when used with a 5V SPI Master.
- (Optional) 3.3 V I²C interface, 100 KHz max.
- Precision fitted bezel in black(-BK) or pearl (-PL)

1 Ordering Information

Note that the kits below require a 5V/1A power supply. It is NOT provided in the development kit, but is offered as an optional accessory with the following part types:

Part No.	Description
VM801B43A-BK	VM801B module, supports 3.3/5V MCU Adapter Board, 4.3" 480x272 resolution TFT LCD display panel preinstalled, black bezel
VM801B50A-BK	VM801B module, supports 3.3/5V MCU Adapter Board, 5" 480x272 resolution TFT LCD display panel preinstalled, black bezel
VM801B43A-PL	VM801B module, supports 3.3/5V MCU Adapter Board, 4.3" 480x272 resolution TFT LCD display panel preinstalled, pearl bezel
VM801B50A-PL	VM801B module, supports 3.3/5V MCU Adapter Board, 5" 480x272 resolution TFT LCD display panel preinstalled, pearl bezel
VA-PSU-UK1	Accessory - UK Model 5V/1A USB Power Supply (Mfr # JX-B0520C-1-B)
VA-PSU-US1	Accessory - US Model 5V/1A USB Power Supply (Mfr # JX-B0520B-1-B)
VA-PSU-EU1	Accessory - EU Model 5V/1A USB Power Supply (Mfr # JX-B0520A-1-B)
VA800A-SPI	Accessory - High Speed Micro USB to SPI adapter for BASIC boards based on FT232H MPSSE design
VA-FC-1M-BKW	Accessory - Flat USB A to Micro B Cable 1M- Black and White
VA-FC-1M-BLW	Accessory - Flat USB A to Micro B Cable 1M- Blue and White

Table 1-1 – Ordering information

Table of Contents

1	Ordering Information	2
2	Hardware Description	4
2.1	VM801B module	4
2.2	Physical Descriptions	5
2.2.1	Dimensions.....	5
2.3	VM801B Connectors	6
3	Board Schematics	9
4	Hardware Setup Guide.....	12
4.1	Power Configuration	12
4.2	MPSSE Setup	12
4.3	Arduino® Setup.....	14
5	Assembling the Bezel and Panel Mounting	15
5.1	4.3" Dimensions.....	16
5.2	5.0" Dimensions.....	17
6	Specifications	18
6.1	Optical Specification	18
7	Contact Information	20
	Appendix A - References	23
	Appendix B - List of Figures and Tables.....	24
	Appendix C – Revision History.....	25

2 Hardware Description

Please refer to section 2.3 for connector settings. Some VM801B jumpers must be set to work properly with your system.

2.1 VM801B module



Figure 2-1 - VM801B module profile 4.3" display version



Figure 2-2 - VM801B module profile 5" display version

NOTE: Also available in pearl.

The VM801B module is intended for direct use into existing applications that require a display. This module is suitable for interfacing with an external microcontroller that has a SPI Master or I²C Master channel.

The VM801B module is available in multiple options: 4.3 or 5.0 inch display options.

The main functions of the VM801B are as follows:

- Micro USB connector
- SPI/I2C connector
- 2-pin connector for power supply
- 3.3V regulator: Takes 5V input and outputs 3.3V for on-board circuits
- LCD touch screen panel
- 5V tolerant buffers between the SPI master interface and the Slave interface of the FT801

- SPI timing requirements can be found in the FT801 datasheet. The on board level converter buffers introduce additional delay. The actual maximum SPI clock frequency depends on the host system timing and connection cable length to the VM801B PCB.
- 3 stage audio filter and power amplifier
- 8Ω speaker and Audio line out option
- Precision fitted bezel

2.2 Physical Descriptions

2.2.1 Dimensions

The VM801B module dimensions are illustrated in Figure 2-3.

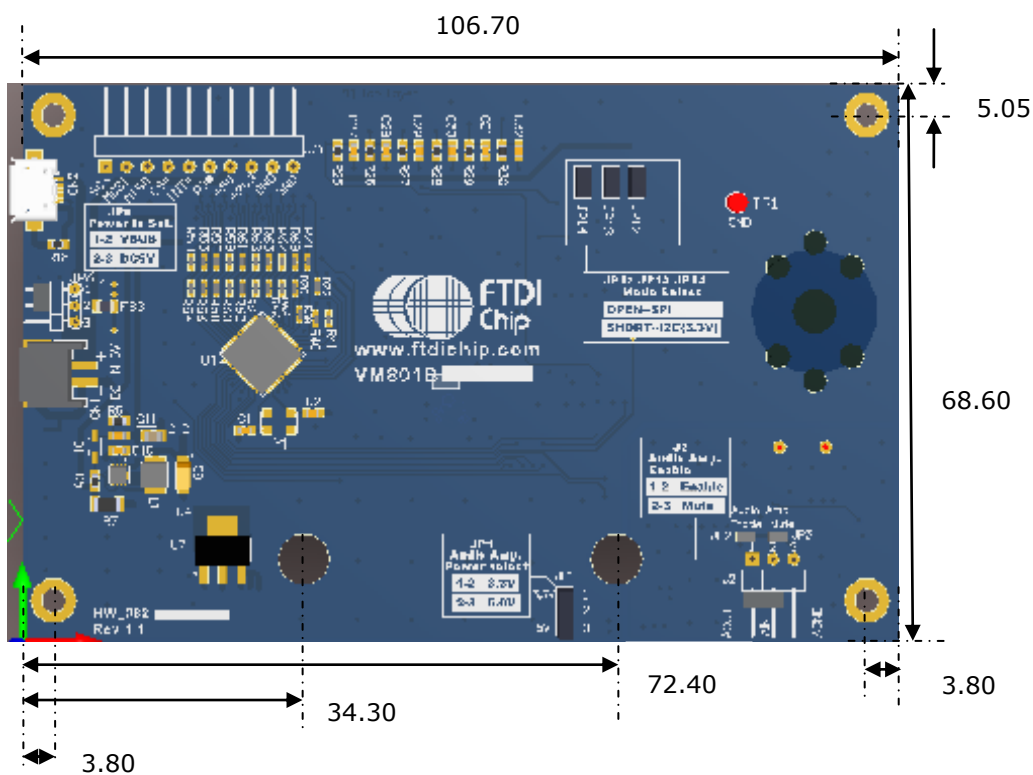

Figure 2-4 - VM801B module PCB view, 4.3 and 5 inch display version

All dimensions are in mm.

2.3 VM801B Connectors

Connectors and jumpers are described in the following sections.

- **CN1- 2-pin power connector**

2 pin connector for 5V/3.3V power input to the board. Alternative to Micro USB connector.

Pin No.	Name	Type	Description
1	VCC	P	5V or 3.3V DC power supply
2	GND	P	Ground

Table 2-1 – CN1 Pinout

- **CN2- Micro USB Receptacle**

This receptacle is strictly for 5V input to power the board. There is no USB Functionality

Pin No.	Name	Type	Description
1	VBUS	P	5V power supply
2	NC	NA	No connection
3	NC	NA	No connection
4	NC	NA	No connection
5	GND	P	Ground

Table 2-2 – CN2 Pinout

- **J2 - Selection between Lineout and loop back into the power amplifier.**

Selection between audio lineout and loop back into the power amplifier.

Jumper position	Description
Short pin 1-2	Audio amp enabled (default)
Short pin 2-3	Audio amp mute, Audio lineout on pin 1

Table 2-3 – J2 Pin Options

- **J5- SPI/I²C Interface**

This is the interface where the SPI/I²C control and data signals are routed to. There are also power and ground pins on this interface.

Pin No.	Name	Type	Description
1	SCLK	I	SPI/I ² C Clock input
2	MOSI	I	Master Out Slave input
3	MISO/SDA	O	Master In Slave out/ I2C Data line
4	CS#	I	Chip select , active low
5	INT#	O	Interrupt output active low
6	PD#	I	Power down control input, active low

Pin No.	Name	Type	Description
7	5V	P	5V power supply
8	3.3V	P	3.3V power supply
9	GND	P	Ground
10	GND	P	Ground

Table 2-4 – J5 Pinout

- **J7- CTP Interface**

This is the capacitive touch panel interface where the I²C control and data signals are routed to. There are also power and ground pins on this interface.

Pin No.	Name	Type	Description
1	3V3	P	3.3V power supply
2	GND	P	Ground
3	SCL	I	I ² C clock input
4	SDA	IO	I ² C data input and output
5	INT#	O	Interrupt output
6	WAKE	I	Wake input

Table 2-5 – J5 Pinout

- **JP1- Audio Amplifier Power Select**

This jumper provides the option to select the power supply voltage for the on-board power amplifier.

Jumper position	Description
Short pin 1-2	3.3V selected (default)
Short pin 2-3	5V selected

Table 2-6 – JP1 Pin options

Note: This needs to be configured before audio can be heard. Default is 3.3V. Select 5V to increase the maximum volume for the speaker.

- **JP2 – On board amplifier enable**

Solder connection not fitted by default.

- **JP3 - On board amplifier mute**

Solder connection not fitted by default.

- **JP6 – Power Input select**

Jumper position	Description
Short pin 1-2	Board power from CN2(default)
Short pin 2-3	Board power from CN1

Table 2-7 – JP6 jumper options

- **JP12, JP13, JP14 – Mode select**

Default mode is SPI. JP12-JP14 are not populated by the factory. To select I²C, user should close both JP12-14.

*Note: The JP12-14 must be both closed to avoid IO signal conflicting in I²C mode.

3 Board Schematics

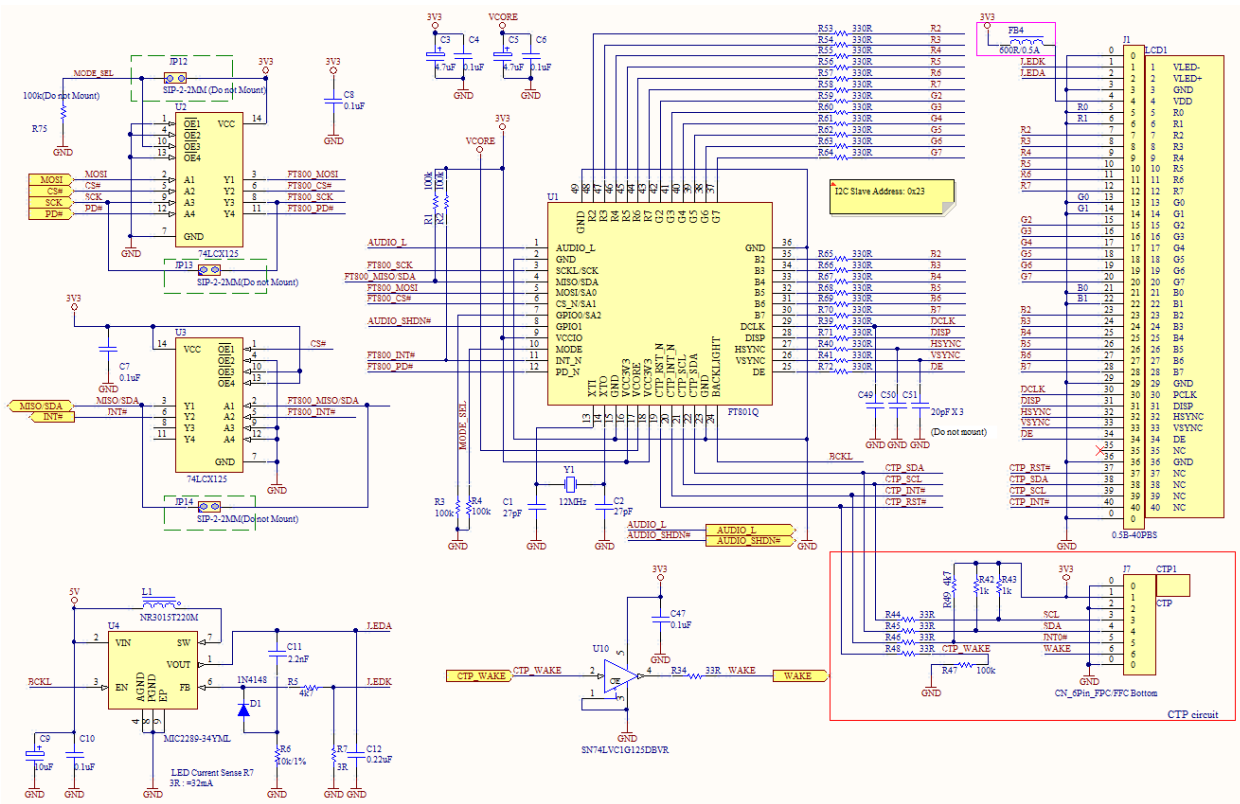

Figure 3-1 - VM801B43A/VM801B50A (4.3"/5.0" Version)

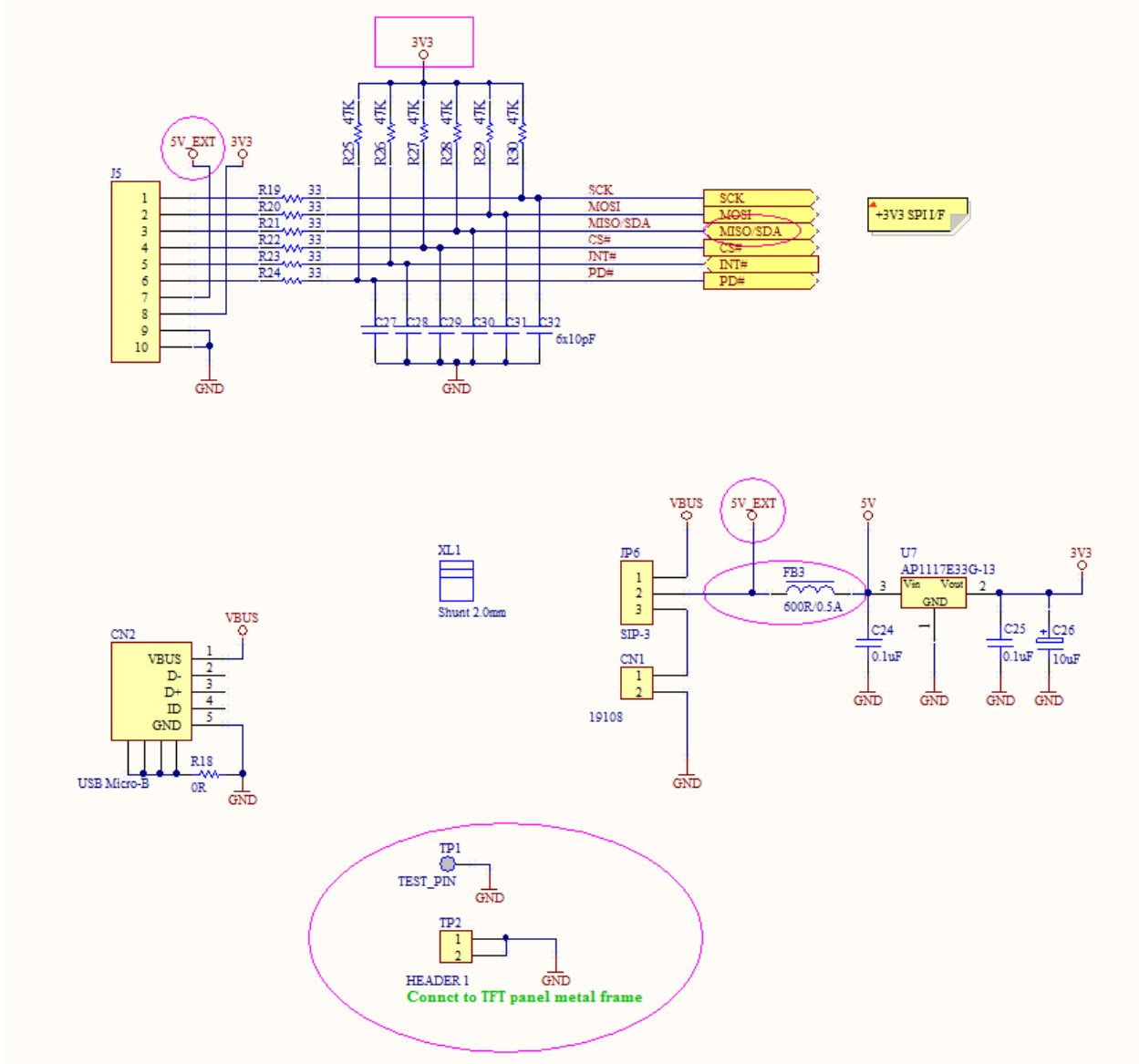

Figure 3-2 – VM801B SPI Interface and IO

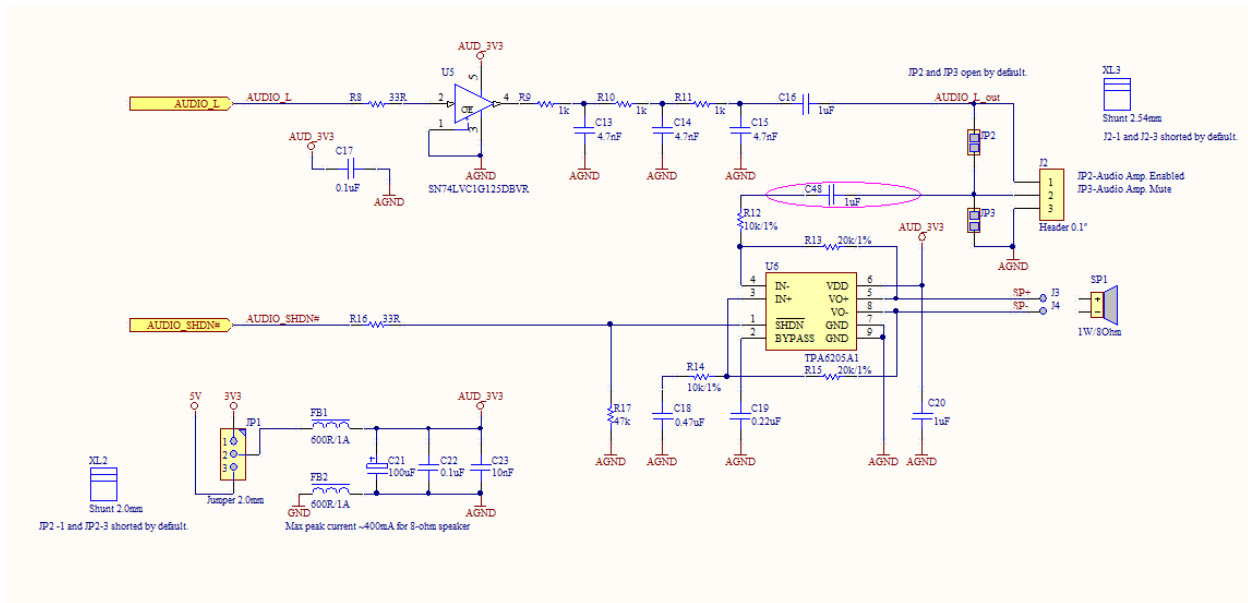

Figure 3-3 – VM801B Audio

4 Hardware Setup Guide

4.1 Power Configuration

There are 5 methods of powering the VM801B board.

- 1) USB Power(5V) - Connect USB power through micro-USB cable to CN2
- 2) DC IN(5V) - Connect 5V to CN1
- 3) DC IN(3.3V) - Connect 3.3V to CN1 and short J5 pin 7 and 8
- 4) J5 Power(5V) - Connect 5V to J5 pin 7
- 5) *J5 Power(3.3V) - Connect 3.3V to J5 pin 7 and 8

*Warning: Applying 5 V accidentally in this mode may cause permanent damage to the VM801B module.

The following table summarise how to power the VM801B board using the various methods.

Power Method	CN2	CN1	J5 Pin 7	J5 Pin 8	JP6
USB Power	5V	N/C	N/C	N/C	Short pin 1-2
DC IN(5V)	N/C	5V	N/C	N/C	Short pin 2-3
DC IN(3.3V)	N/C	3.3V	SHORT		Short pin 2-3
J5 Power(5V)	N/C	N/C	5V	N/C	Any Position
J5 Power (3.3V)	N/C	N/C	3.3V		Any Position

Table 4-1 - Board power configuration

4.2 MPSSE Setup

To provide a quick start with the VM801B development board, Windows based sample projects including source code are provided. An overview of the process is provided in the following paragraphs with more details in [AN 245 VM800CB SampleAPP PC Introduction](#)

MPSSE is a "multi purpose synchronous serial engine" interface available in some FTDI devices (e.g. FT2232D, FT232H, FT2232H, FT4232H, FT4222H and the modules built based on these silicon chips). This engine allows users to bridge from a USB port on a PC to an I²C or SPI interface. Sample code is available for driving the FT801 over this interface with a FT232H device.

VA800A-SPI is a MPSSE module accessory which can connect to the VM801B modules directly. Detailed information on the VA800A-SPI can be found at:

<http://www.ftdichip.com/Products/modules/VA800A-SPI.html>

FTDI also provide a multipurpose MPSSE cable assembly C232HM-EDHSL-0(5V) or C232HM-DDHSL-0(3.3V) for rapid setup. More information on the cable may be found at:

http://www.ftdichip.com/Support/Documents/DataSheets/Cables/DS_C232HM_MPSSE_CABLE.pdf.

In this section it is assumed the VA800A-SPI is used. VA800A-SPI supplies 5 V for VM801B modules. If the VM801B is connected to an SPI interface with a 3.3 V power supply, refer to table 5-1 for the board power configuration. Note, improper power supply and/or IO voltage connection may damage the VM801B module.

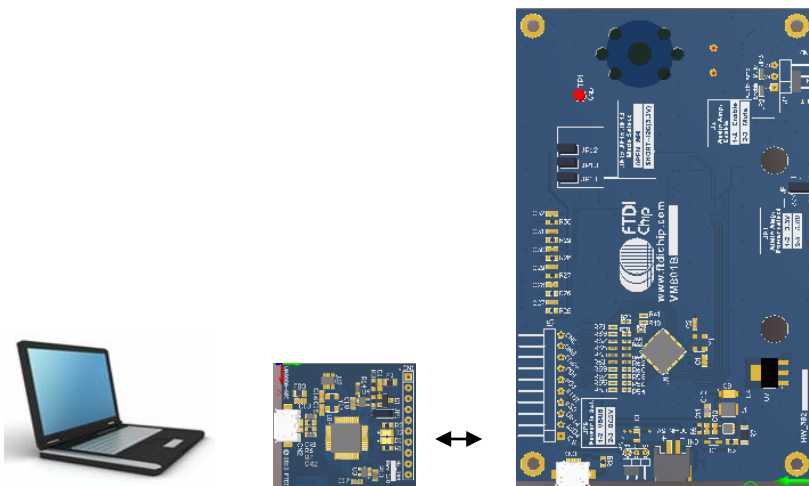

Figure 4-1 – VM801B connects to PC through VA800A-SPI accessory.

Hardware Setup

- Connect the VA800A-SPI to the VM801B module in the correct orientation (with J5-pin1 of the VM801B board connected to CN1-pin1 of VA800A-SPI board).
- Connect a USB cable (suggest FTDI accessory **VA-FC-1M-BKW** or **VA-FC-1M-BLW**) from the VA800A-SPI to the PC USB host port or self-powered hub port.
- The VA800A-SPI will supply power to the VM801B after the MPSSE driver is properly loaded and the USB host completes USB device configuration.

NOTE: If using the C232HM-EDHSL-0(5V) MPSSE cable then the connection is as:

J5 Pin number	J5 Signal	MPSSE pin number	MPSSE Signal	MPSSE Cable Lead Colour
1	SCK	2	SK	ORANGE
2	MOSI	3	DO	YELLOW
3	MISO/SDA	4	DI	GREEN
4	CS#	5	CS	BROWN
5	INT#	7	GPIOL1	PURPLE
6	PD#	9	GPIOL3	BLUE
7	5V	1	VCC	RED
8	3.3V	-	-	-
9	GND	10	GND	Black
10	GND	-	-	-

Table 4-2 – MPSSE cable (C232HM-EDHSL-0) connection

Software Setup

- The following software setup steps apply to both the VA800A-SPI and MPSSE cable assembly.
- Download the MPSSE software. MPSSE cable and driver information can be found at <http://www.ftdichip.com/Products/Cables/USBMPSSE.htm>.
- Launch the demo application based on MPSSE from the PC

4.3 Arduino® Setup

Sample code and demo applications are provided to users who want to connect the VM801B to a MCU. FTDI provides sample source code, sample application notes and a ready to run demo based on the Arduino® platform. Detailed information can be found at:
<http://www.ftdichip.com/Products/Modules/VM801B.html>

5 Assembling the Bezel and Panel Mounting

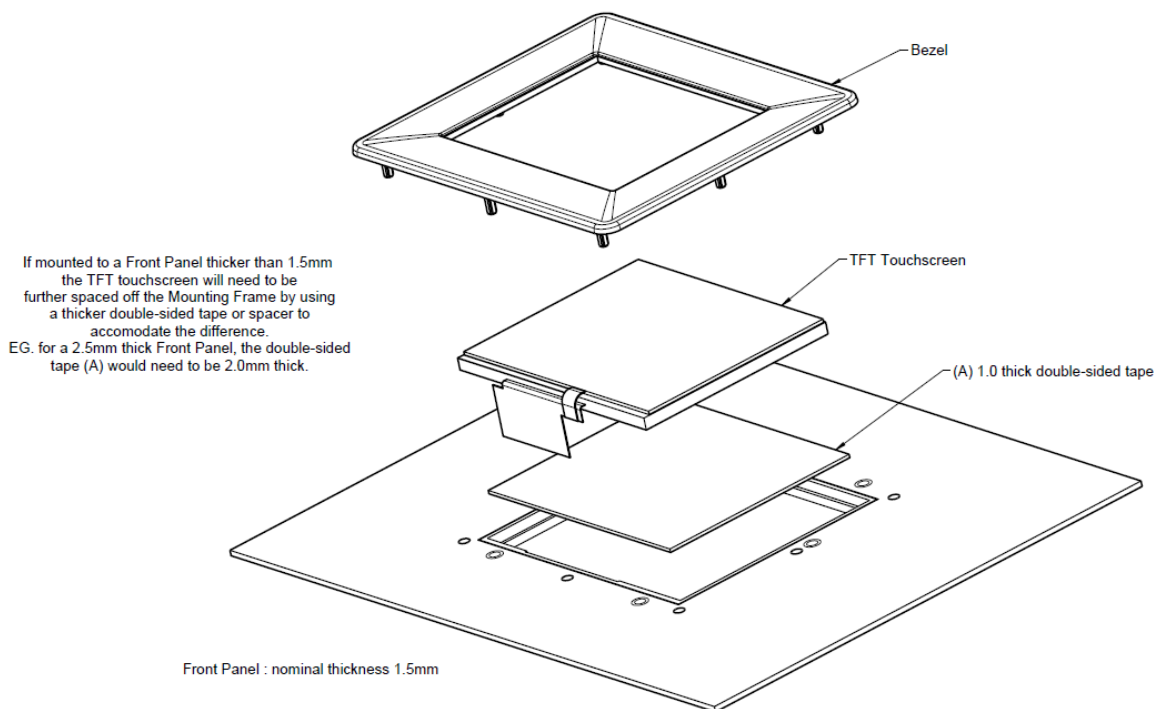

Figure 5-1 - VM801B Panel Mount (Front view)

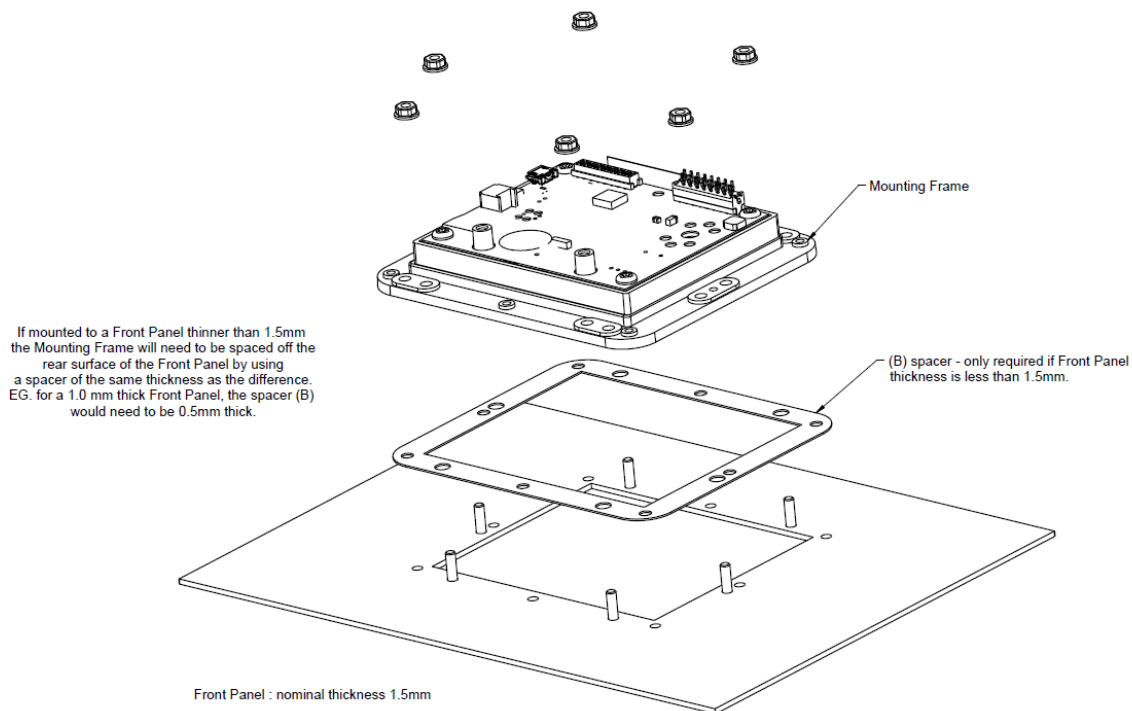

Figure 5-2 - VM801B Panel Mount (Rear view)

6 Specifications

6.1 Optical Specification

Item	Symbol	Condition	Min.	Typ.	Max.	Unit	Note	
Brightness (With CP)	Bp	$\theta=0^\circ$	400	450	-	Cd/m ²	1	
Uniformity	\triangle Bp	$\Phi=0^\circ$	75	80	-	%	1,2	
Viewing Angle	3:00	Cr \geq 10	-	60	-	Deg	3	
	6:00		-	45	-			
	9:00		-	60	-			
	12:00		-	60	-			
Contrast Ratio	Cr	$\theta=0^\circ$ $\Phi=0^\circ$	300	500	-	-	4	
Response Time	T _r		-	10	-	ms	5	
	T _f		-	10	-	ms		
Color of CIE Coordinate	W	x		0.28		-	1,6	
		y		0.33		-		
	R	x		0.51		-		
		y		0.34		-		
	G	x	$\theta=0^\circ$ $\Phi=0^\circ$		0.31			-
		y			0.56			-
	B	x			0.15			-
		y			0.14			-
NTSC Ratio	S		50	60	-	%		

Table 6-1 - 4.3" TFT Optical Specification

Item	Symbol	Condition	Min.	Typ.	Max.	Unit	Note
Brightness	Bp	$\theta=0^\circ$	200	250	-	Cd/m ²	1
Uniformity	Δ Bp	$\Phi=0^\circ$	70	80	-	%	1,2
Viewing Angle	3:00	Cr \geq 10	-	45	-	Deg	3
	6:00		-	25	-		
	9:00		-	45	-		
	12:00		-	45	-		
Contrast Ratio	Cr	$\theta=0^\circ$ $\Phi=0^\circ$	350	500	-	-	4
Response Time	T _r		-	10	-	ms	5
	T _f	-	10	-	ms		
Color of CIE Coordinate	W	x	$\theta=0^\circ$ $\Phi=0^\circ$	0.28	-	1,6	
		y		0.33	-		
	R	x		0.51	-		
		y		0.34	-		
	G	x		0.31	-		
		y		0.56	-		
	B	x		0.15	-		
		y		0.14	-		
NTSC Ratio	S	50	60	-	%		

Table 6-2 - 5" TFT Optical Specification

7 Contact Information

Head Office – Glasgow, UK

Unit 1, 2 Seaward Place, Centurion Business Park
Glasgow G41 1HH
United Kingdom
Tel: +44 (0) 141 429 2777
Fax: +44 (0) 141 429 2758

E-mail (Sales) sales1@ftdichip.com
E-mail (Support) support1@ftdichip.com
E-mail (General Enquiries) admin1@ftdichip.com

Branch Office – Tigard, Oregon, USA

7130 SW Fir Loop
Tigard, OR 97223
USA
Tel: +1 (503) 547 0988
Fax: +1 (503) 547 0987

E-Mail (Sales) us.sales@ftdichip.com
E-Mail (Support) us.support@ftdichip.com
E-Mail (General Enquiries) us.admin@ftdichip.com

Branch Office – Taipei, Taiwan

2F, No. 516, Sec. 1, NeiHu Road
Taipei 114
Taiwan, R.O.C.
Tel: +886 (0) 2 8797 1330
Fax: +886 (0) 2 8751 9737

E-mail (Sales) tw.sales1@ftdichip.com
E-mail (Support) tw.support1@ftdichip.com
E-mail (General Enquiries) tw.admin1@ftdichip.com

Branch Office – Shanghai, China

Room 1103, No. 666 West Huaihai Road,
Changning District, Shanghai, 200052
China
Tel: +86 (0)21 6235 1596
Fax: +86 (0)21 6235 1595

E-mail (Sales) cn.sales@ftdichip.com
E-mail (Support) cn.support@ftdichip.com
E-mail (General Enquiries) cn.admin@ftdichip.com

Web Site

<http://ftdichip.com>

Distributor and Sales Representatives

Please visit the Sales Network page of the [FTDI Web site](#) for the contact details of our distributor(s) and sales representative(s) in your country.

System and equipment manufacturers and designers are responsible to ensure that their systems, and any Future Technology Devices International Ltd (FTDI) devices incorporated in their systems, meet all applicable safety, regulatory and system-level performance requirements. All application-related information in this document (including application descriptions, suggested FTDI devices and other materials) is provided for reference only. While FTDI has taken care to assure it is accurate, this information is subject to customer confirmation, and FTDI disclaims all liability for system designs and for any applications assistance provided by FTDI. Use of FTDI devices in life support and/or safety applications is entirely at the user's risk, and the user agrees to defend, indemnify and hold harmless FTDI from any and all damages, claims, suits or expense resulting from such use. This document is subject to change without notice. No freedom to use patents or other intellectual property rights is implied by the publication of this document. Neither the whole nor any part of the information contained in, or the product described in this document, may be adapted or reproduced in any material or electronic form without the prior written consent of the copyright holder. Future Technology Devices International Ltd, Unit 1, 2 Seaward Place, Centurion Business Park, Glasgow G41 1HH, United Kingdom. Scotland Registered Company Number: SC136640

Appendix A - References

FT801 datasheet: [DS_FT801_Embedded_Video_Engine](#)

FT800 software programming guide: [FT800_Series_Programmer_Guide](#)

FT800 sample application notes:

[AN_245_VM800CB_SampleAPP_PC_Introduction](#)

[AN_246_VM800CB_SampleAPP_Arduino_Introduction](#)

C232HM-EDHSL-0 datasheet:

http://www.ftdichip.com/Support/Documents/DataSheets/Cables/DS_C232HM_MPSSE_CABLE.pdf

D2xx Programmers Guide:

[http://www.ftdichip.com/Support/Documents/ProgramGuides/D2XX_Programmer's_Guide\(FT_000071\).pdf](http://www.ftdichip.com/Support/Documents/ProgramGuides/D2XX_Programmer's_Guide(FT_000071).pdf)

AN_108: Command Processor for MPSSE and MCU Host Bus Emulation Modes

http://www.ftdichip.com/Support/Documents/AppNotes/AN_108_Command_Processor_for_MPSSE_and_MCU_Host_Bus_Emulation_Modes.pdf

Appendix B - List of Figures and Tables

List of Figures

Figure 2-1 - VM801B module profile 4.3" display version	4
Figure 2-2 - VM801B module profile 5" display version	4
The VM801B module dimensions are illustrated in Figure 2-3.	5
Figure 2-4 - VM801B module PCB view, 4.3 and 5 inch display version.....	5
Figure 3-1 - VM801B43A/VM801B50A (4.3"/5.0" Version).....	9
Figure 3-2 – VM801B SPI Interface and IO	10
Figure 3-3 – VM801B Audio	11
Figure 4-1 – VM801B connects to PC through VA800A-SPI accessory.	13
Figure 5-1 - VM801B Panel Mount (Front view)	15
Figure 5-2 - VM801B Panel Mount (Rear view)	15
Figure 5-3 - VM801B 4.3" panel mount dimensions	16
Figure 5-4 - VM801B 5.0" panel mount dimensions	17

List of Tables

Table 1-1 – Ordering information	2
Table 2-1 – CN1 Pinout.....	6
Table 2-2 – CN2 Pinout.....	6
Table 2-3 – J2 Pin Options	6
Table 2-4 – J5 Pinout	7
Table 2-5 – J5 Pinout	7
Table 2-6 – JP1 Pin options	7
Table 2-7 – JP6 jumper options.....	8
Table 4-1 - Board power configuration.....	12
Table 4-2 – MPSSE cable (C232HM-EDHSL-0) connection.....	13
Table 6-1 - 4.3" TFT Optical Specification.....	18
Table 6-2 - 5" TFT Optical Specification	19

Appendix C – Revision History



Document Title: DS_VM801B
Document Reference No.: FT_001073
Clearance No.: FTDI#425
Product Page: www.ftdichip.com/Products/Modules/VM801B.html
Document Feedback: [Send Feedback](#)

Version 1.0 Initial Datasheet released

25/11/2014

Looking for pricing, stock, or lifecycle information?

Click below to explore more details on WIN SOURCE:

-  [View VM801B50A-BK on WIN SOURCE](#)
-  [Bridgetek Pte Ltd. Information](#)

Optimize Your Supply Chain with WIN SOURCE Solutions

-  Global Sourcing Solution
-  Obsolete Management
-  Cost Control Management
-  Shortage Management
-  Alternative Solution
-  Excess Inventory Management