

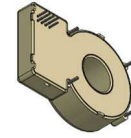

**THE DATASHEET OF
T60404N4641X903**



Differential Current Sensor for IC-CPD acc. to the partly combined standards IEC62752-1:2016 and UL2231-2 Ed.2



Date: 11.10.2021

K-No.:26924

Customer: Standard type

Page 1 of 7

Description

- Fluxgate current sensor with toroidal core
- PCB mounting

Characteristics

- Excellent accuracy
- AEC-Q qualified components
- Switching open-collector outputs
- Compact design

Applications

Mainly used for stationary and mobile applications:

- IC-CPD acc. to IEC62752
- Personnel Protection Systems for EV acc. to UL2231

Patents: EP2571128 / US9397494 / CN103001175 // EP2813856

Electrical data – Ratings

		min.	typ.	max.	Unit
I_P	Primary rated current (1phase / 3phase)			80 / 40	A
$I_{\Delta N1}$	Rated residual fault current 1		6		mA dc
$I_{\Delta N2}$	Rated residual fault current 2		20		mA rms
$I_{\Delta N1, tolerance}$	Trip tolerance 1	4		6	mA dc
$I_{\Delta N2, tolerance}$	Trip tolerance 2	15		20 ⁽¹⁾ / 70 ⁽²⁾	mA rms
$S_{PWM-OUT}$	Scaling factor of the DC component $I_{\Delta N1}$ (for monitoring purpose only!)		2		%/mA
$I_{\Delta RI, 1/2}$ (Fig.1)	Recovery current level for $I_{\Delta N1}$ or $I_{\Delta N2}$ (absolute value dc/rms)		2.5 / 10		mA

(1) f = rated frequency (2) f = 2kHz

Accuracy – Dynamic performance data

$I_{\Delta N, max}$	Measuring range (peak)	-300		+300	mA
X	Resolution (@ $I_{\Delta N}$, $\Theta_A = 25^\circ C$)		< 0.2		mA
t_r	Response times		According to IEC62752:2016 ⁽³⁾ According to UL2231-2 Ed.2		
f_{BW}	Frequency range	DC		2	kHz

General data

ϑ_A	Ambient operation temperature	-40		85	°C
$\vartheta_{Storage}$	Ambient storage temperature ⁽⁴⁾	-40		85	°C
m	Mass		21		g
V_{CC}	Supply voltage	4.8	5	5.2	V
I_{CC}	Supply current	38		45	mA rms
$S_{clear, ps}$	Clearance (primary to secondary)	not applicable if insulated cable is used ⁽⁵⁾			
$S_{creep, ps}$	Creepage (primary to secondary)	not applicable if insulated cable is used ⁽⁵⁾			
FIT	EN/IEC 61709 / SN 29500 ⁽⁶⁾ (MIL-HDBK-217F) ⁽⁶⁾		1529 (6349)		fit

⁽³⁾ Switching time of a standard relay (IEC: t = 20ms / UL: t = 10ms) is considered.

⁽⁴⁾ see VAC M-sheet 3101; storage temperature inside cardboard packaging

⁽⁵⁾ Constructed, manufactured and tested in accordance with IEC60664-1:2007

Isolated wires are preferred. If isolated primary conductors are used, the isolation coordination is according to: Reinforced insulation, Insulation material group 1, Pollution degree 2, altitude ≤ 4000m and overvoltage category II.

⁽⁶⁾ The results are valid under following conditions: 55°C mean component ambient temperature by continuous operation (8760h per year); Environment condition: ground mobile, no dust or harmful substances, according to IEC61709; Fit equals one failure per 10⁹ component hours.

General description of sensor function:

The Sensor is sensitive to AC and DC current and can be used for fault current detection in IC-CPD applications. The Sensor detects DC fault currents according to IEC62752:2016 and AC fault currents according to UL2231-2 Ed.2. In the event of a DC fault current, PIN 3 will change its state from a low level (GND) to high impedance state. In the event of an AC fault current, PINs 3 and 4 will change state from a low level (GND) to a high impedance state.

Error conditions (e.g. an internal error) are signaled by PIN 1 (ERROR-OUT) which changes state to high impedance.

Datum	Name	Index	Änderung
11.10.2021	BZ	84	Patents added on sheet 1. CN-21-290
02.07.19	BZ	84	Sheet 4, Product test 3.4a deleted. CN-19-171
Editor.:R&D-PD-NPI D		Designer: MB	MC-PM: BZ
			Released by: SB

Typical application diagram:

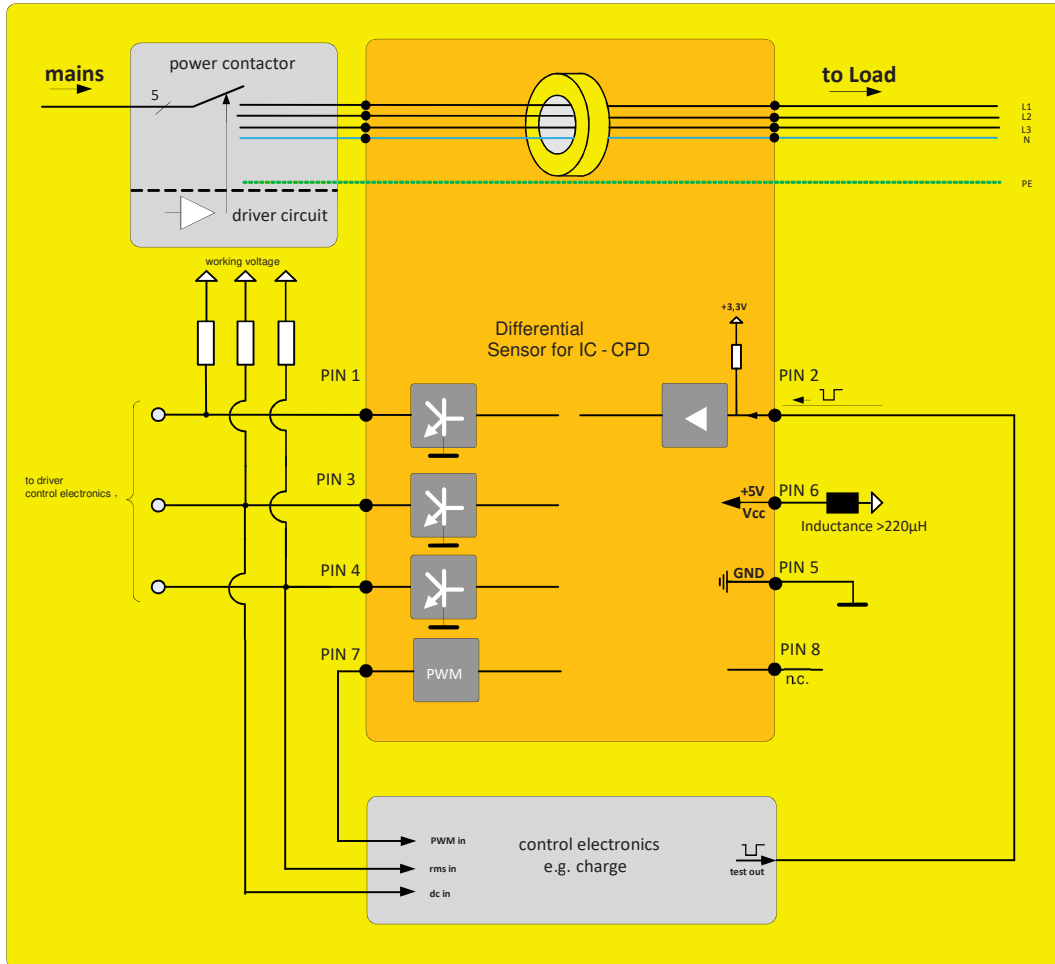

Absolute maximum ratings⁽⁶⁾:

		Min.	Typ.	Max.	Unit
V_{CE}	Collector-emitter voltage (PINs 1, 3 and 4)			40	V
I_C	Collector current (PINs 1, 3 and 4)			50	mA
V_{CC}	Maximum supply voltage (without function)	-0.3		7	V
U_{MAX}	Maximum rated voltage of primary conductors (AC rms)			250	V
$V_{TEST-IN, low}$	TEST-IN Input Voltage, low level	0		0.6	V
$V_{TEST-IN, high}$	TEST-IN Input Voltage, high level	2.5		5	V

⁽⁶⁾Stresses above these ratings may cause permanent damage.
Exposure to these conditions for extended periods may degrade device reliability.
Functional operation of the device at these or any other conditions beyond those specified is not supported.

**Differential Current Sensor for IC-CPD
acc. to the partly combined standards
IEC62752-1:2016 and UL2231-2 Ed.2**

Date: 11.10.2021

K-No.:26924

Customer: Standard type

Page 4 of 7

Final Tests: (Measurements after temperature balance of the samples at room temperature, SC=significant characteristic)

		Min.	Max.	Unit
Vcc	Supply voltage	4.9	5.1	V
Icc	Supply current	37.0	45.0	mA
TEST-IN (SC)	TEST-IN voltage	2.8	3.4	V
X6-OUT (normal)	X6-OUT voltage	0	0.6	V
X20-OUT (normal)	X20-OUT voltage	0	0.6	V
ERROR-OUT (normal)	ERROR-OUT voltage	0	0.6	V
X6-OUT (activated)	X6-OUT voltage activated @5V, 1kΩ (pull-up)*	4.9	5.1	V
X20-OUT (activated)	X20-OUT voltage activated @5V, 1kΩ (pull-up)*	4.9	5.1	V
ERROR-OUT (activated)	ERROR-OUT voltage activated @5V, 1kΩ (pull-up)*	4.9	5.1	V
TC1	Trip current 1 – X6	4.1	5.4	mA
TC2	Trip current 2 – X6	-5.4	-4.1	mA
TC3	Trip current 3 – X20@60Hz	15	20	mA
PWM-OUT (frequency)	PWM-OUT frequency	7.8	8.2	kHz
PWM-OUT (duty-cycle)	PWM-OUT duty-cycle @6mA, 60Hz	11	13	%
LV1	Limit values of break time - X6-OUT@6mA DC	0	700	ms
LV2	Limit values of break time - X6-OUT@30mA DC	0	500	ms
LV3	Limit values of break time – X20-OUT@20mA, 60Hz	0	1000	ms
LV4	Limit values of break time – X20OUT@100mA,60Hz	0	100	ms

* the maximum values of collector-emitter voltage and current see “Absolute maximum ratings”

Product Tests:

	Acc. to VAC sheet M3238 Following tests differ from M3238:	passed	
	4.5a: Damp heat, steady state. Duration: 1000 h		
PD	IEC61000-4-1, EN60270, M3024 UPDE M3024, Partial discharge voltage (extinction) *acc. to table 24	1.5	kV _{RMS}
ESD	Air- and contact discharge; U=±2000V, R=1500Ω, C=100pF Acc. to Human Body Model JESD22-A114	±2.0	kV
	IEC61000-4-3 (Radiated, radio-frequency, electromagnetic field immunity) 20V/m 80MHz – 1GHz 80%AM 1kHz, recommend with the use of inductance of >220μH in series of Vcc input.	passed	
EMC	CISPR 14-1 (Immunity to conducted disturbances), recommend with the use of inductance of >220μH in series of Vcc input.	passed	
	IEC61000-6-4 (Emission standard for industrial environments, conducted disturbances)	Should be done in end application	
A(f), φ (f)	Amplitude and phase response over frequency 1% of I _{PN} or I _{Δn}	passed	
Impulse test	Monitoring of CS function during the current phase test 100A to 5kA	passed	

Differential Current Sensor for IC-CPD acc. to the partly combined standards IEC62752-1:2016 and UL2231-2 Ed.2

Date: 11.10.2021

K-No.:26924

Customer: Standard type

Page 5 of 7

Requalification Tests: (replicated every year, Precondition acc. to M3238)

$\hat{U}_{W, \text{prim-sec}}$	M3064	Impulse test (1.2µs/50µs waveform) PIN 1-8 vs. insulated primary wire 5 pulse → polarity +, 5 pulse → polarity -	5.5	kV
U_d	M3014	Test voltage, 60s PIN 1-8 vs. insulated primary wire	1.5	kV rms
U_{PDE}	M3024	Partial discharge voltage (extinction) PIN 1-8 vs. insulated primary wire *acc. to table 24	1.2	kV rms
$U_{PD} \times 1.875$	M3024	Partial discharge voltage (extinction) PIN 1-8 vs. insulated primary wire *acc. to table 24	1.5	kV rms

* IEC 61800-5-1:2007

Other instructions:

- Temperature of the primary conductor should not exceed 105°C.
- Vcc during Test-IN function test must be in rated range.
- Fall- and rise-time of Vcc: $t > 10\mu\text{s/V}$
- Further standards UL 2231 E-file No. 488116, category FFUQ2 / FFUQ8

Figures:

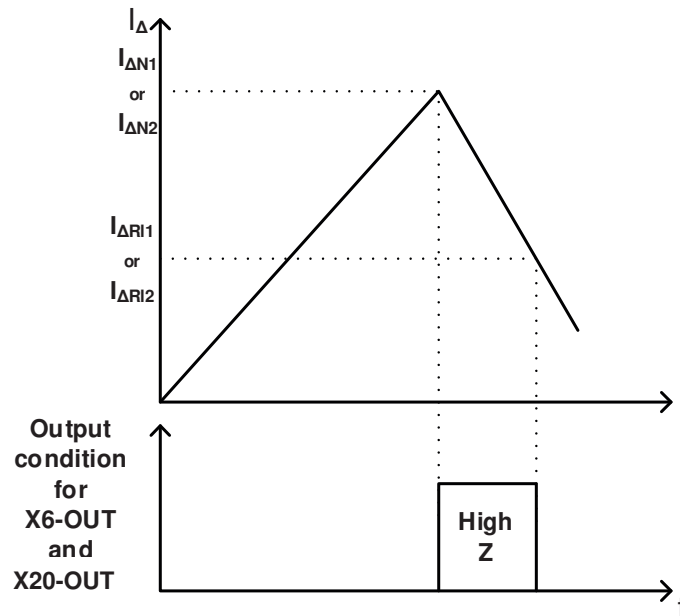
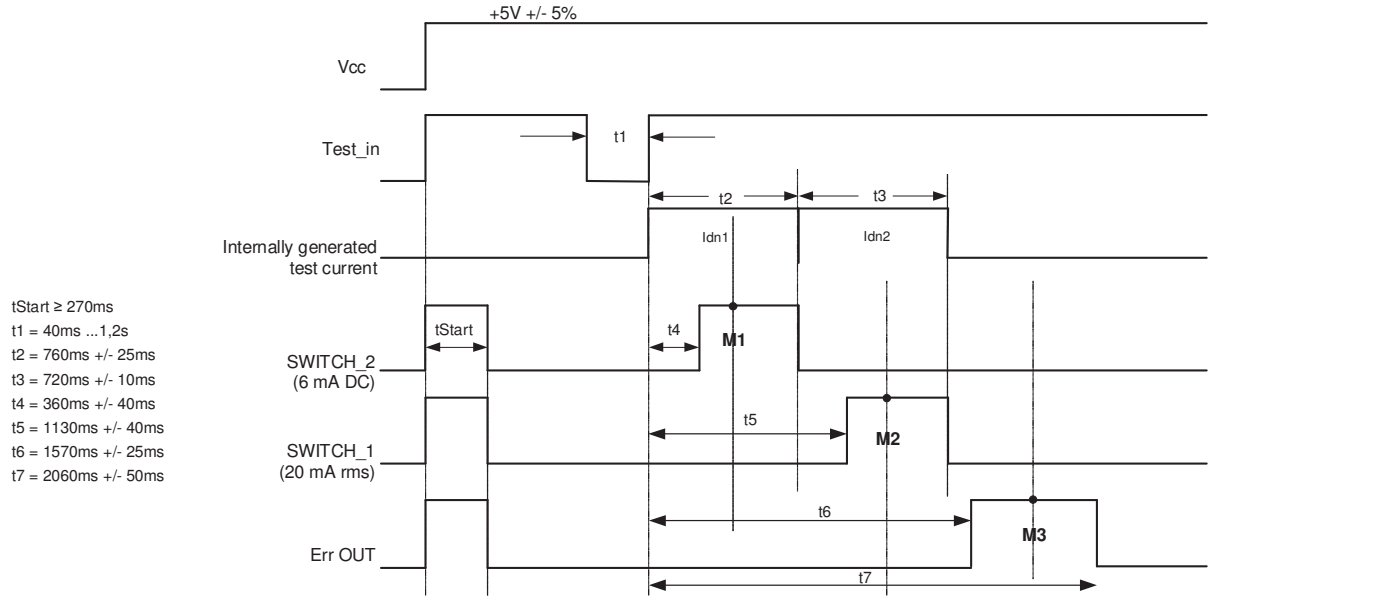

Fig. 1: Meaning of switching recovery level

If the trip-level $I_{\Delta N1}/I_{\Delta N2}$ is accomplished the corresponding output X6-OUT/X20-OUT will change its state from low-level (GND) to high impedance. Depending on the existence of the differential current I_{Δ} , the outputs X6-OUT/X20-OUT will remain in their states until I_{Δ} is below the recovery threshold $I_{\Delta R11}/I_{\Delta R12}$.



During functional test, a residual current detection is not available

After activating the test sequence, the end product has to monitor the correct state of the switching outputs being used at the following points in time:

- M1: check that „SWITCH_2“ (6mA DC) is disabled
- M2: check that „SWITCH_1“ (20mA rms) is disabled
- M3: check that Err OUT is disabled

● = charger electronics to monitor level

Fig. 2: Power-Up timing diagram

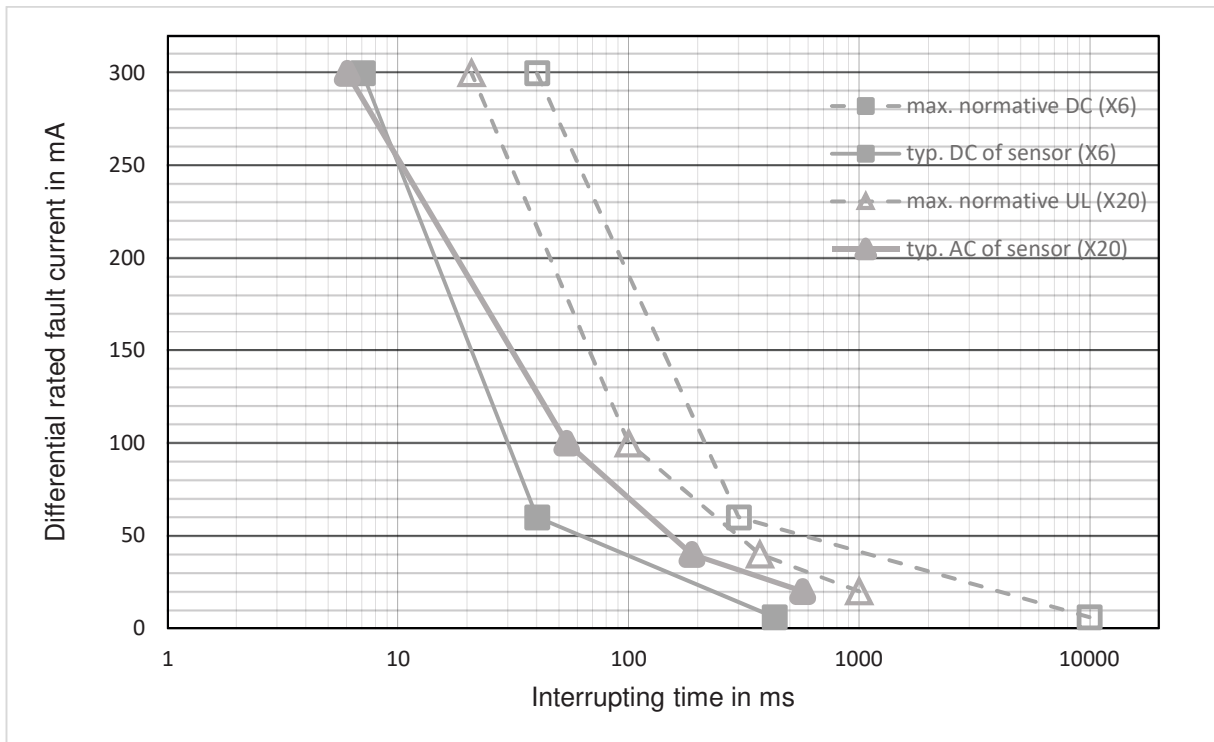

Fig. 3: Interrupting Time according to IEC62752 (E)-1:2016, UL2231-2 Ed.2 and typical values of sensor

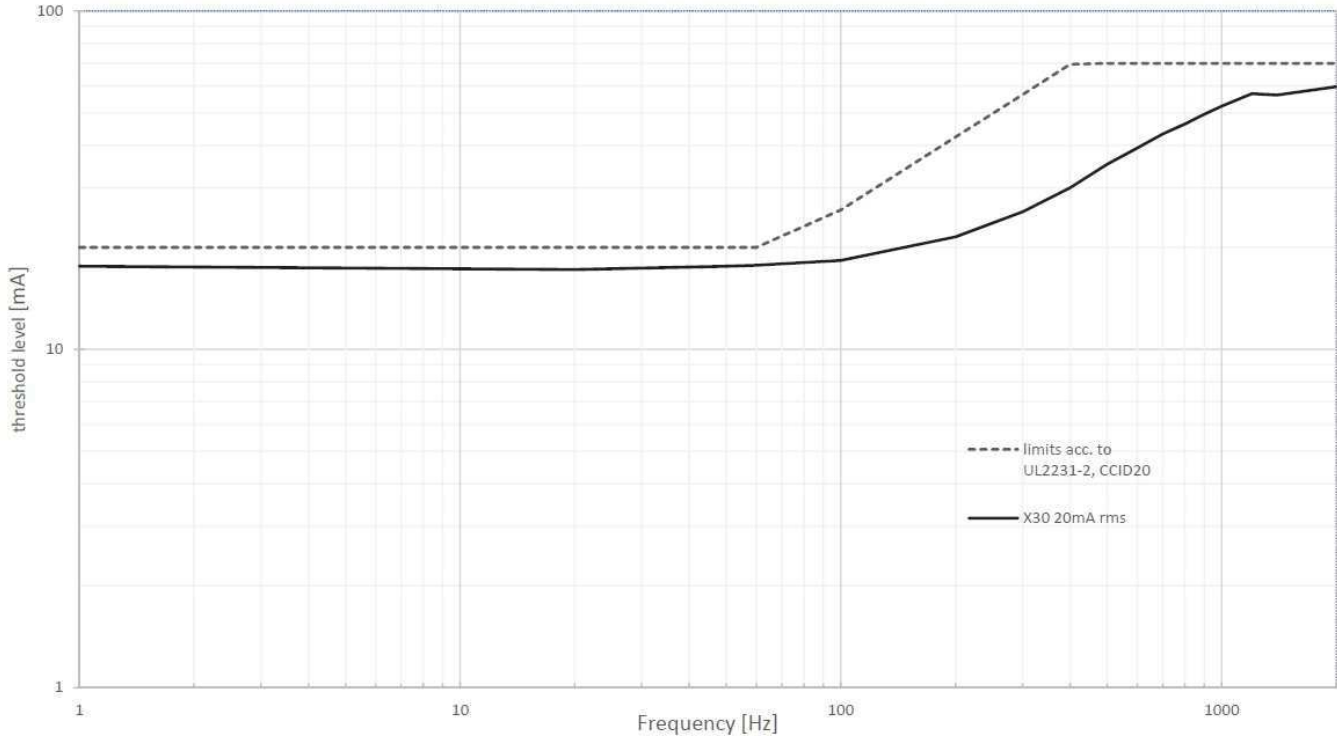

Fig. 4:UL2231 response value over frequency

X6-OUT	X20-OUT	ERROR-OUT	State
GND	GND	GND	Normal condition
High impedance	GND	GND	$I_{\Delta N1} \geq 6mA_{DC}$
High impedance	High impedance	GND	$I_{\Delta N2} \geq 20mA_{rms}$
High impedance	High impedance	High impedance	Error, system fault
All other conditions not mentioned in the table are not possible. If these conditions occur, the sensor is an unknown state and describes an Error.			

Table 1: Possible output states

Looking for pricing, stock, or lifecycle information?

Click below to explore more details on WIN SOURCE:

- ⊖ [View T60404N4641X903 on WIN SOURCE](#)
- ⊖ [VACUUMSCHMELZE Information](#)

Optimize Your Supply Chain with WIN SOURCE Solutions

- ✓ Global Sourcing Solution
- ✓ Obsolete Management
- ✓ Cost Control Management
- ✓ Shortage Management
- ✓ Alternative Solution
- ✓ Excess Inventory Management