



**THE DATASHEET OF  
P9S121-S20D3**



RPC-1.35 Calibration Adaptor  
Plug - Plug

**P9S121-S20D3**

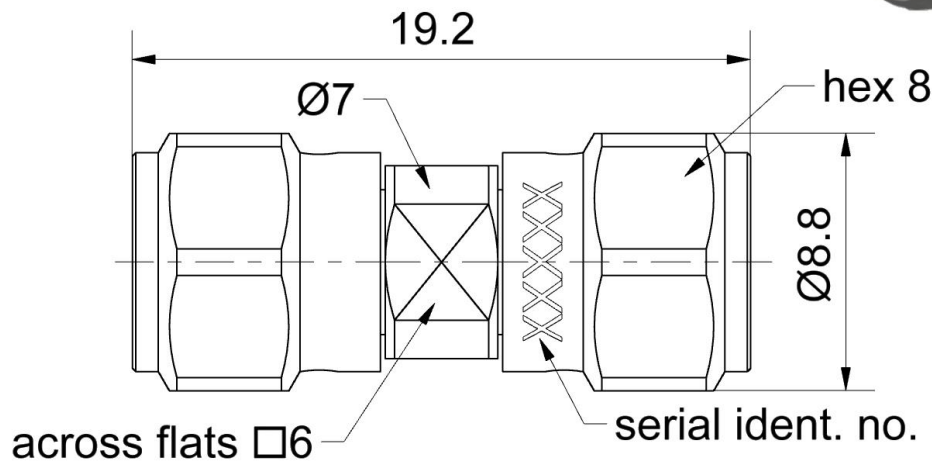
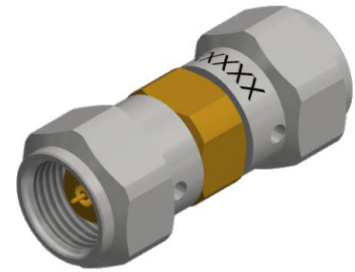

All dimensions are in mm; tolerances according to ISO 2768 m-H

**Interface**

According to IEC 61169-65

**Documents**

Application note AN001 "Calibration Services"

**Material and plating**

**Connector parts**

Center conductor  
Outer conductor  
Coupling nut  
Dielectric

**Material**

CuBe  
CuBe or equiv.  
Stainless steel  
PEEK

**Plating**

Gold, min. 1.27µm  
Gold, min. 1.27µm  
Passivated

**Electrical data**

Frequency range DC to 90 GHz

This calibration standard is designed to be part of a Rosenberger RPC-1.35 calibration kit, e.g. P9CK010-150 or P9CK001-150. Please consult the data sheet of one of the mentioned calibration kits for the specified Residual System Data in that application.

Return loss  $\geq 31$  dB, DC to 10 GHz  
 $\geq 24$  dB, 10 GHz to 30 GHz  
 $\geq 20$  dB, 30 GHz to 50 GHz  
 $\geq 18$  dB, 50 GHz to 60 GHz  
 $\geq 15$  dB, 60 GHz to 90 GHz

**Mechanical data**

Mating cycles  $\geq 3000$   
 Maximum torque 1.65 Nm  
 Recommended torque 0.90 Nm  
 Gauge 0.003 mm to 0.020 mm

**General standard definitions**

For proper operation the vector network analyzer (VNA) needs a model describing the electrical behaviour of this calibration standard. The different models, units, and terms used will depend on the VNA type and they will have to be entered into the VNA. All values are based on typical geometry and plating.

Offset  $Z_o$  / Impedance /  $Z_o$  50  $\Omega$   
 Offset Delay 53.97 ps  
 Length (electrical) / Offset Length 16.18 mm  
 Offset Loss 5.95 G $\Omega$ /s  
 Loss 0.0558 dB/ $\sqrt{\text{GHz}}$

**Environmental data**

Operating temperature range<sup>1</sup> +20 °C to +26 °C  
 Rated temperature range of use<sup>2</sup> 0 °C to +50 °C  
 Storage temperature range - 40 °C to +85 °C

RoHS compliant

<sup>1</sup> Temperature range over which these specification are valid.

<sup>2</sup> This range is underneath and above the operating temperature range, within the calibration adaptor is fully functional and could be used without damage.

RPC-1.35 Calibration Adaptor  
Plug - Plug

**P9S121-S20D3**

**Declaration of calibration options**

**Factory Calibration**

Standard delivery for this calibration standard includes a Factory Calibration. In a Calibration Certificate individual calibration results, traceable to national / international standards are reported. Model based standard definitions are reported in an Agilent/Keysight, Rohde & Schwarz and Anritsu compatible VNA format.

**Accredited Calibration**

Not available.

*For further, more detailed information see application note AN001 on the Rosenberger homepage.*

**Calibration interval**

Recommendation 12 months

**Packing**

Standard 1 pce in box  
Weight 5.0 g/pce

While the information has been carefully compiled to the best of our knowledge, nothing is intended as representation or warranty on our part and no statement herein shall be construed as recommendation to infringe existing patents. In the effort to improve our products, we reserve the right to make changes judged to be necessary.

For the installation of the electrotechnical equipment, particular electrotechnical expertise is required.



Draft	Date	Approved	Date	Rev.	Engineering change number	Name	Date
Marcel Panicke	16.11.18	Lars Ramtke	20.05.22	c00	22-0943	David d'Argent	24.05.22

Rosenberger Hochfrequenztechnik GmbH & Co. KG  
P.O.Box 1260 D-84526 Tittmoning Germany  
[www.rosenberger.de](http://www.rosenberger.de)

Tel. : +49 8684 18-0  
Email : [info@rosenberger.de](mailto:info@rosenberger.de)

Page  
3 / 3

## Looking for pricing, stock, or lifecycle information?

Click below to explore more details on WIN SOURCE:

- [View P9S121-S20D3 on WIN SOURCE](#)
- [Rosenberger Hochfrequenztechnik GmbH & Co. KG Information](#)

## Optimize Your Supply Chain with WIN SOURCE Solutions

- ✓ Global Sourcing Solution
- ✓ Obsolete Management
- ✓ Cost Control Management
- ✓ Shortage Management
- ✓ Alternative Solution
- ✓ Excess Inventory Management