



**THE DATASHEET OF
MAL218197203E3**



Conductive Polymer Aluminum Capacitors SMD (Chip), Low Impedance

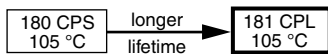

Fig. 1

QUICK REFERENCE DATA	
DESCRIPTION	VALUE
Nominal case sizes (L x W x H in mm)	6.6 x 6.6 x 5.9 to 10.4 x 10.4 x 12.6
Rated capacitance range, C _R	18 µF to 820 µF
Tolerance on C _R	± 20 %
Rated voltage range, U _R	4.0 V to 35 V
Category temperature range	-55 °C to +105 °C
Endurance test at 105 °C	5000 h
Useful life at 105 °C	5000 h
Shelf life at 0 V, 105 °C	1000 h
Based on sectional specification	IEC 60384-18 / CECC 32300
Climatic category IEC 60068	55 / 105 / 56

FEATURES

- Long useful life: up to 5000 h at 105 °C
- Very low ESR and highest ripple current
- SMD-version with base plate, lead (Pb)-free reflow solderable
- Material categorization: for definitions of compliance please see www.vishay.com/doc?99912



APPLICATIONS

- SMD technology, for high temperature reflow soldering
- Industrial and professional applications
- Telecommunications and IT
- Portable and mobile equipment

MARKING

- Rated capacitance (in µF)
- Rated voltage (in V)
- Date code, in accordance with IEC 60062
- Blue mark or “-” sign indicating the cathode (the anode is identified by bevelled edges)
- Code indicating group number (L)

PACKAGING

Supplied in blister tape on reel

SELECTION CHART FOR C_R , U_R , AND RELEVANT NOMINAL CASE SIZES (L x W x H in mm)							
C_R (μF)	U_R (V)						
	4.0	6.3	10	16	20	25	35
18	→	→	→	→	→	→	6.6 x 6.6 x 5.9
39	→	→	→	6.6 x 6.6 x 5.9	-	-	-
47	→	→	→	→	→	6.6 x 6.6 x 5.9	-
56	→	→	6.6 x 6.6 x 5.9	→	6.6 x 6.6 x 5.9	-	-
68	→	→	6.6 x 6.6 x 5.9	6.6 x 6.6 x 5.9	-	-	-
82	→	→	→	8.4 x 8.4 x 6.7	→	→	8.4 x 8.4 x 12
100	→	6.6 x 6.6 x 5.9	→	10.4 x 10.4 x 7.7	-	-	-
120	→	6.6 x 6.6 x 5.9	6.6 x 6.6 x 5.9	8.4 x 8.4 x 6.7	-	-	-
150	6.6 x 6.6 x 5.9	→	8.4 x 8.4 x 6.7	8.4 x 8.4 x 6.7	→	8.4 x 8.4 x 12	10.4 x 10.4 x 12.6
			10.4 x 10.4 x 7.7				
180	→	→	→	10.4 x 10.4 x 7.7	-	-	-
220	→	6.6 x 6.6 x 5.9	-	-	-	-	-
		8.4 x 8.4 x 6.7					
270	8.4 x 8.4 x 6.7	→	8.4 x 8.4 x 6.7	→	8.4 x 8.4 x 12	10.4 x 10.4 x 12.6	-
330	6.6 x 6.6 x 5.9	→	10.4 x 10.4 x 7.7	-	-	-	-
	8.4 x 8.4 x 6.7						
390	→	8.4 x 8.4 x 6.7	→	→	8.4 x 8.4 x 12	-	-
470	→	10.4 x 10.4 x 7.7	→	→	10.4 x 10.4 x 12.6	-	-
560	8.4 x 8.4 x 6.7	-	-	-	-	-	-
680	10.4 x 10.4 x 7.7	-	-	-	-	-	-
820	→	→	→	10.4 x 10.4 x 12.6	-	-	-

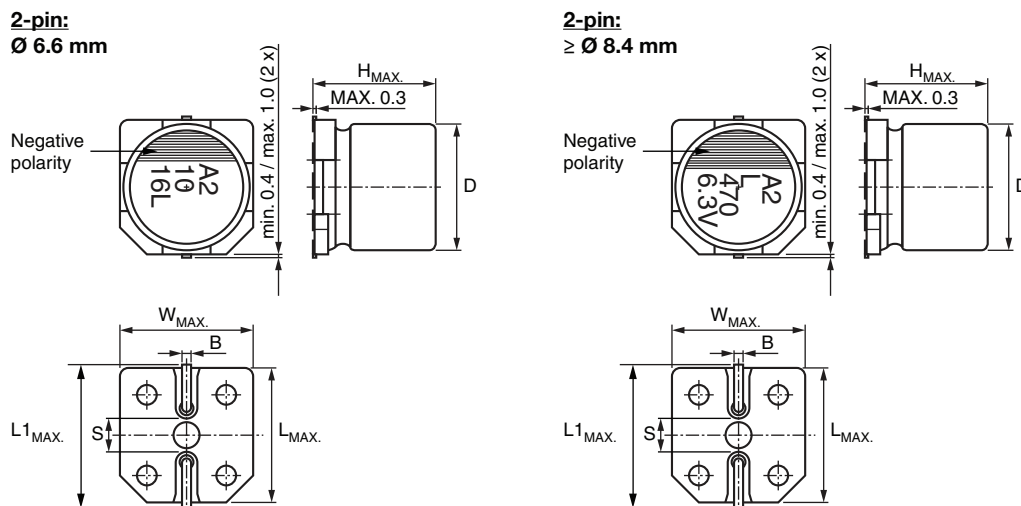

Fig. 2 - Dimensional outline



Fig. 3 - Coplanarity of pins

Table 1

DIMENSIONS in millimeters AND MASS									
NOMINAL CASE SIZE L x W x H	CASE CODE	L _{MAX.}	W _{MAX.}	H _{MAX.}	Ø D	B _{MAX.}	S	L1 _{MAX.}	MASS (g)
6.6 x 6.6 x 5.9	0606	6.8	6.8	6	6.3	0.8	2.0	7.4	~ 0.25
8.4 x 8.4 x 6.7	0807	8.6	8.6	7	8	1.1	3.1	9.2	~ 0.5
8.4 x 8.4 x 12	0812	8.6	8.6	12.5	8	1.1	3.1	9.2	~ 0.8
10.4 x 10.4 x 7.7	1008	10.6	10.6	8	10	1.3	4.7	11.2	~ 0.9
10.4 x 10.4 x 12.6	1013	10.6	10.6	12.7	10	1.3	4.7	11.2	~ 1.3

Table 2

TAPE AND REEL DIMENSIONS in millimeters, PACKAGING QUANTITIES						
NOMINAL CASE SIZE L x W x H	CASE CODE	PITCH P ₁	TAPE WIDTH W	TAPE THICKNESS T ₂	REEL DIAMETER	PACKAGING QUANTITY PER REEL
6.6 x 6.6 x 5.9	0606	12	16	6.2	380	1000
8.4 x 8.4 x 6.7	0807	12	16	6.8	380	1000
8.4 x 8.4 x 12	0812	16	16	13.0	380	400
10.4 x 10.4 x 7.7	1008	16	24	10.0	380	500
10.4 x 10.4 x 12.6	1013	16	24	14.0	380	400

MOUNTING

The capacitors are designed for automatic placement on to printed-circuit boards.

Optimum dimensions of soldering pads depend amongst others on soldering method, mounting accuracy, print layout and / or adjacent components.

For recommended soldering pad dimensions, refer to Fig. 4 and Table 3.

SOLDERING

Soldering conditions are defined by the curve, temperature versus time, where the temperature is that measured on the component during processing.

For maximum conditions refer to Fig. 5.

Any temperature versus time curve which does not exceed the specified maximum curves may be applied.

As a general principle, temperature and duration shall be the **minimum** necessary required to ensure good soldering connections. However, the specified maximum curves should never be exceeded.

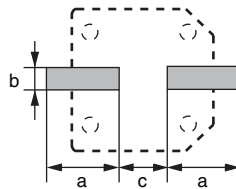

Fig. 4 - Recommended soldering pad dimensions

Table 3

RECOMMENDED SOLDERING PAD DIMENSIONS in millimeters			
CASE CODE	a	b	c
0606	1.9	3.5	1.6
0807	3.0	3.5	2.5
0812	3.0	3.5	2.5
1008	4.0	4.0	2.5
1013	4.0	4.0	2.5

ADVANCED SOLDERING PROFILE FOR LEAD (Pb)-FREE REFLOW PROCESS

Fig. 5 - Maximum temperature load during reflow soldering

Table 4

REFLOW SOLDERING CONDITIONS for MAL2181xxxxxE3	
PROFILE FEATURES	CASE CODE 0606 TO 1013
Max. time from 25 °C to T_{Peak}	300 s
Max. ramp-up rate to 150 °C	3 K/s
Max. time from 150 °C to 200 °C (t_1)	150 s
Max. time from 190 °C to 200 °C (t_2)	110 s
Ramp up rate from 200 °C to T_{Peak}	0.5 K/s to 3 K/s
Max. time above $T_{Liquidus}$ (217 °C) (t_3)	90 s
Max. time above 230 °C (t_4)	70 s
Peak temperature T_{Peak}	260 °C
Max. time above T_{Peak} minus 5 °C	40 s
Ramp-down rate from $T_{Liquidus}$	3 K/s to 6 K/s

Note

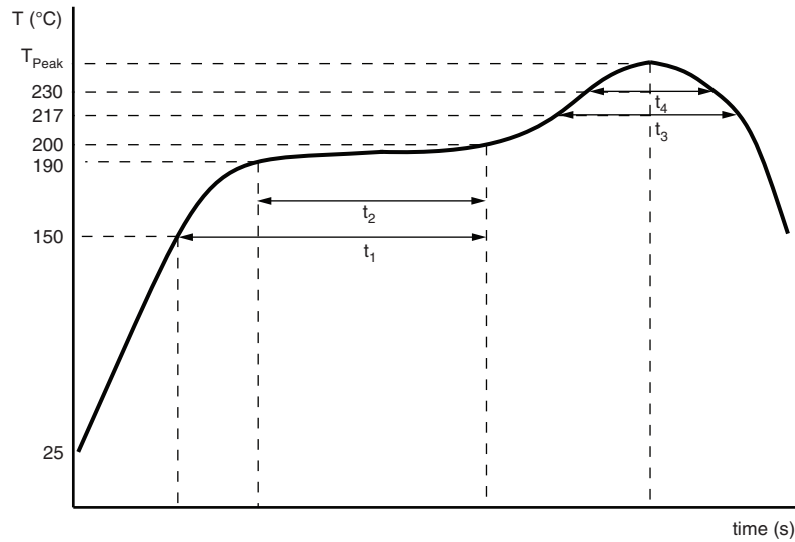
- Temperature measuring point on top of the case and on terminals.



ELECTRICAL DATA	
SYMBOL	DESCRIPTION
C_R	Rated capacitance at 100 Hz, tolerance $\pm 20\%$
I_R	Rated RMS ripple current at 100 kHz, 105 °C
I_{L2}	Max. leakage current after 2 min at U_R
$\tan \delta$	Max. dissipation factor at 100 Hz
Z	Max. impedance at 100 kHz

Note

- Unless otherwise specified, all electrical values in Table 5 apply at $T_{amb} = 20\text{ °C}$, $P = 86\text{ kPa}$ to 106 kPa , $RH = 45\%$ to 75%

Table 5

ELECTRICAL DATA AND ORDERING INFORMATION							
U_R (V)	C_R (μF)	NOMINAL CASE SIZE L x W x H (mm)	I_R 105 °C 100 kHz (mA)	I_{L2} 2 min (μA)	$\tan \delta$ 100 Hz	Z 100 kHz 20 °C (Ω)	ORDERING CODE MAL2181...
4.0	150	6.6 x 6.6 x 5.9	2570	120	0.12	0.022	97701E3
	270	8.4 x 8.4 x 6.7	3220	216	0.12	0.022	97702E3
	330	6.6 x 6.6 x 5.9	2800	264	0.12	0.020	97703E3
	330	8.4 x 8.4 x 6.7	3220	264	0.12	0.022	97704E3
	560	8.4 x 8.4 x 6.7	3600	448	0.12	0.018	97705E3
	680	10.4 x 10.4 x 7.7	4130	544	0.12	0.020	97706E3
6.3	100	6.6 x 6.6 x 5.9	2800	126	0.12	0.022	97301E3
	120	6.6 x 6.6 x 5.9	2800	151	0.12	0.022	97302E3
	220	6.6 x 6.6 x 5.9	2800	277	0.12	0.020	97303E3
	220	8.4 x 8.4 x 6.7	3220	277	0.12	0.022	97306E3
	390	8.4 x 8.4 x 6.7	3220	491	0.12	0.022	97307E3
	470	10.4 x 10.4 x 7.7	4130	592	0.12	0.020	97308E3
10	56	6.6 x 6.6 x 5.9	2300	112	0.12	0.027	97401E3
	68	6.6 x 6.6 x 5.9	2300	136	0.12	0.027	97402E3
	120	6.6 x 6.6 x 5.9	2300	240	0.12	0.027	97403E3
	150	8.4 x 8.4 x 6.7	2760	300	0.12	0.030	97404E3
	150	10.4 x 10.4 x 7.7	3020	300	0.12	0.030	97405E3
	270	8.4 x 8.4 x 6.7	3200	540	0.12	0.022	97406E3
	330	10.4 x 10.4 x 7.7	3770	660	0.12	0.024	97407E3
16	39	6.6 x 6.6 x 5.9	2200	125	0.12	0.030	97501E3
	68	6.6 x 6.6 x 5.9	2200	218	0.12	0.030	97502E3
	82	8.4 x 8.4 x 6.7	2800	262	0.12	0.028	97503E3
	100	10.4 x 10.4 x 7.7	2670	320	0.12	0.035	97504E3
	120	8.4 x 8.4 x 6.7	2800	384	0.12	0.028	97505E3
	180	10.4 x 10.4 x 7.7	3430	576	0.12	0.029	97506E3
	820	10.4 x 10.4 x 12.6	5400	2624	0.12	0.012	97507E3
20	56	6.6 x 6.6 x 5.9	1300	224	0.12	0.048	97201E3
	270	8.4 x 8.4 x 12	4000	1080	0.12	0.021	97202E3
	390	8.4 x 8.4 x 12	4950	1560	0.12	0.014	97203E3
	470	10.4 x 10.4 x 12.6	4300	1880	0.12	0.020	97204E3
25	47	6.6 x 6.6 x 5.9	1300	235	0.12	0.049	97601E3
	150	8.4 x 8.4 x 12	2200	750	0.12	0.028	97602E3
	270	10.4 x 10.4 x 12.6	2700	1350	0.12	0.027	97603E3
35	18	6.6 x 6.6 x 5.9	900	126	0.12	0.064	97001E3
	82	8.4 x 8.4 x 12	2200	574	0.12	0.029	97002E3
	150	10.4 x 10.4 x 12.6	2600	1050	0.12	0.028	97003E3

ORDERING EXAMPLE

Conductive polymer 181 CPL series

100 μF / 16 V; $\pm 20\%$

Nominal case size: 10.4 mm x 10.4 mm x 7.7 mm; taped on reel

Ordering code: MAL218197504E3

Table 6

ADDITIONAL ELECTRICAL DATA		
PARAMETER	CONDITIONS	VALUE
Voltage		
Surge voltage for short periods	IEC 60384-18, subclause 4.14	$U_S \leq 1.15 \times U_R$
Reverse voltage for short periods	IEC 60384-18, subclause 4.16; $T_A \leq 105 \text{ }^\circ\text{C}$	$U_{rev} \leq 1 \text{ V}$

USEFUL LIFE AND ENDURANCE
Table 7

ENDURANCE TEST AND USEFUL LIFE				
SERIES	CASE CODE	USEFUL LIFE AT 105 °C (h)	ENDURANCE AT 105 °C (h)	ENDURANCE AT 85 °C (h)
181 CPL	0606 to 1013	5000	5000	50 000

Endurance can be calculated by formula below:

$$L_r = L_0 \times 10^{\frac{T_0 - T_r}{20}}$$

 L_r : estimated lifetime (h)

 L_0 : base lifetime specified at maximum operating temperature with applied the DC voltage (h)

 T_0 : rated maximum operating temperature (°C)

 T_r : actual ambient temperature (°C)

Table 8

TEST PROCEDURES AND REQUIREMENTS			
TEST		PROCEDURE (quick reference)	REQUIREMENTS
NAME OF TEST	REFERENCE		
Mounting	IEC 60384-18, subclause 4.3	Shall be performed prior to tests mentioned below; reflow soldering; for maximum temperature load refer to chapter "Mounting"	$\Delta C/C: \pm 5 \%$ $\tan \delta \leq \text{spec. limit}$ $I_{L2} \leq \text{spec. limit}$
Endurance	IEC 60384-18 / CECC 32300, subclause 4.15	$T_{amb} = 105 \text{ }^\circ\text{C}$; U_R applied; for test duration see Table 7	$\Delta C/C: \pm 20 \%$ $\tan \delta \leq 2 \times \text{spec. limit}$ $I_{L2} \leq \text{spec. limit}$
Useful life	CECC 30301, subclause 1.8.1	$T_{amb} = 105 \text{ }^\circ\text{C}$; U_R and I_R applied; for test duration see Table 7	$\Delta C/C: \pm 20 \%$ $\tan \delta \leq 2 \times \text{spec. limit}$ $I_{L2} \leq \text{spec. limit}$
Shelf life (storage at high temperature)	IEC 60384-18 / CECC 32300, subclause 4.17	$T_{amb} = 105 \text{ }^\circ\text{C}$; no voltage applied; 1000 h after test: U_R to be applied for 30 min, 24 h to 48 h before measurement	For requirements see "Endurance test" above

Statements about product lifetime are based on calculations and internal testing. They should only be interpreted as estimations. Also due to external factors, the lifetime in the field application may deviate from the calculated lifetime. In general, nothing stated herein shall be construed as a guarantee of durability.



Disclaimer

ALL PRODUCT, PRODUCT SPECIFICATIONS AND DATA ARE SUBJECT TO CHANGE WITHOUT NOTICE TO IMPROVE RELIABILITY, FUNCTION OR DESIGN OR OTHERWISE.

Vishay Intertechnology, Inc., its affiliates, agents, and employees, and all persons acting on its or their behalf (collectively, "Vishay"), disclaim any and all liability for any errors, inaccuracies or incompleteness contained in any datasheet or in any other disclosure relating to any product.

Vishay makes no warranty, representation or guarantee regarding the suitability of the products for any particular purpose or the continuing production of any product. To the maximum extent permitted by applicable law, Vishay disclaims (i) any and all liability arising out of the application or use of any product, (ii) any and all liability, including without limitation special, consequential or incidental damages, and (iii) any and all implied warranties, including warranties of fitness for particular purpose, non-infringement and merchantability.

Statements regarding the suitability of products for certain types of applications are based on Vishay's knowledge of typical requirements that are often placed on Vishay products in generic applications. Such statements are not binding statements about the suitability of products for a particular application. It is the customer's responsibility to validate that a particular product with the properties described in the product specification is suitable for use in a particular application. Parameters provided in datasheets and / or specifications may vary in different applications and performance may vary over time. All operating parameters, including typical parameters, must be validated for each customer application by the customer's technical experts. Product specifications do not expand or otherwise modify Vishay's terms and conditions of purchase, including but not limited to the warranty expressed therein.

Hyperlinks included in this datasheet may direct users to third-party websites. These links are provided as a convenience and for informational purposes only. Inclusion of these hyperlinks does not constitute an endorsement or an approval by Vishay of any of the products, services or opinions of the corporation, organization or individual associated with the third-party website. Vishay disclaims any and all liability and bears no responsibility for the accuracy, legality or content of the third-party website or for that of subsequent links.

Vishay products are not designed for use in life-saving or life-sustaining applications or any application in which the failure of the Vishay product could result in personal injury or death unless specifically qualified in writing by Vishay. Customers using or selling Vishay products not expressly indicated for use in such applications do so at their own risk. Please contact authorized Vishay personnel to obtain written terms and conditions regarding products designed for such applications.

No license, express or implied, by estoppel or otherwise, to any intellectual property rights is granted by this document or by any conduct of Vishay. Product names and markings noted herein may be trademarks of their respective owners.

Looking for pricing, stock, or lifecycle information?

Click below to explore more details on WIN SOURCE:

 [View MAL218197203E3 on WIN SOURCE](#)

 [Vishay Information](#)

Optimize Your Supply Chain with WIN SOURCE Solutions

-  Global Sourcing Solution
-  Obsolete Management
-  Cost Control Management
-  Shortage Management
-  Alternative Solution
-  Excess Inventory Management