



**THE DATASHEET OF  
PI3B16210A**



**Features**

- Near-Zero propagation delay
- 5-ohm switches connect inputs to outputs
- Fast Switching Speed: 4.5ns max.
- 32x384 function with flow-through pinout make board layout easier
- V<sub>CC</sub> Operating Range: 3.0V to 3.6V
- Industrial operating temperature: -40°C to +85°C
- Packaging (Pb-free & Green available):
  - 48-pin 150-mil wide plastic BQSOP (B)
  - 48-pin 240-mil wide plastic TSSOP (A)
  - 48-pin 300-mil wide plastic SSOP (V)

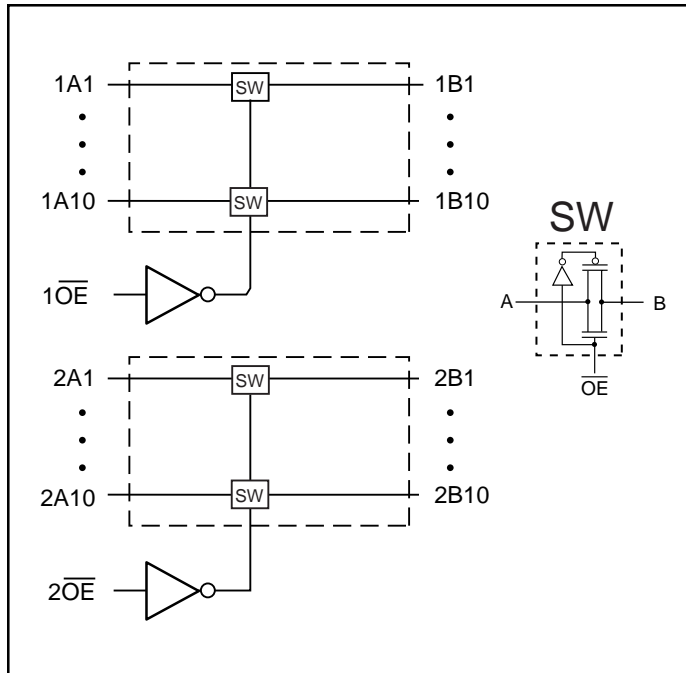
**Block Diagram**

**Truth Table<sup>(1)</sup>**

Inputs		Inputs/Outputs	
1 $\overline{\text{OE}}$	2 $\overline{\text{OE}}$	1A,1B	2A,2B
L	L	1A = 1B	2A = 2B
L	H	1A = 1B	Z
H	L	Z	2A = 2B
H	H	Z	Z

**Note:**

1. H = High Voltage Level  
L = Low Voltage Level  
Hi-Z = High Impedance

**Description**

Pericom Semiconductor's PI3B16210 is configured as a 3.3 volt 20-bit, 2-port bus switch designed with a low On-Resistance (5-ohms) allowing inputs to be connected directly to outputs. The bus switch creates no additional propagational delay or additional ground bounce noise. Switches are turned ON by the Bus Enable (xOE) input signal.

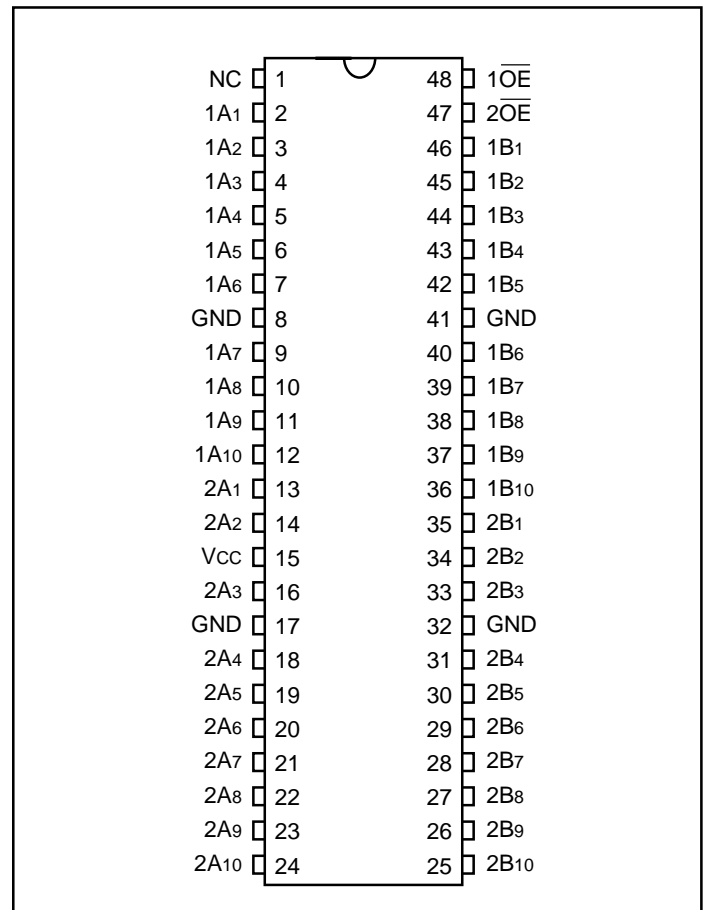
**Pin Configuration**

**Pin Description**

Pin Name	Description
1 $\overline{\text{OE}}$ , 2 $\overline{\text{OE}}$	Bus Enable Inputs (Active LOW)
1A1-1A10, 2A1-2A10	Bus A
1B1 - 1B10, 2B1 - 2B10	Bus B

**Maximum Ratings**

(Above which the useful life may be impaired. For user guidelines, not tested.)

Storage Temperature .....	-65°C to +150°C
Ambient Temperature with Power Applied .....	-0°C to +85°C
Supply Voltage Range .....	-0.5V to +4.6V
DC Input Voltage .....	-0.5V to +4.6V
DC Output Current .....	120mA
Power Dissipation .....	0.5W

**Note:**

Stresses greater than those listed under MAXIMUM RATINGS may cause permanent damage to the device. This is a stress rating only and functional operation of the device at these or any other conditions above those indicated in the operational sections of this specification is not implied. Exposure to absolute maximum rating conditions for extended periods may affect reliability.

**DC Electrical Characteristics** (Over the Operating Range,  $T_A = -40^\circ\text{C}$  to  $+85^\circ\text{C}$ ,  $V_{CC} = 3.0\text{V}$  to  $3.6\text{V}$ )

Parameters	Description	Test Conditions <sup>(1)</sup>	Min.	Typ <sup>(2)</sup>	Max.	Units
$V_{IH}$	Input HIGH Voltage	Guaranteed Logic HIGH Level	2.0	–	–	V
$V_{IL}$	Input LOW Voltage	Guaranteed Logic LOW Level	-0.5	–	0.8	
$I_I$	Input Current	$V_{CC} = \text{Max}, V_{IN} = V_{CC}$ or GND	–	–	$\pm 1$	$\mu\text{A}$
		$V_{CC} = 0\text{V}, V_{IN} = V_{CC}$			$\pm 1$	
$I_{OZH}$	High Impedance Output Current	$0 \leq A, B \leq V_{CC}$	–	–	10	
$V_{IK}$	Clamp Diode Voltage	$V_{CC} = \text{Min.}, I_{IN} = -18\text{mA}$	–	-0.7	-1.2	V
$R_{ON}$	Switch ON Resistance <sup>(3)</sup>	$V_{CC} = 3\text{V}, V_{IN} = 0.0\text{V}$ $I_{ON} = 24\text{mA}, 64\text{mA}$	–	5	8	$\Omega$
		$V_{CC} = 3\text{V}, V_{IN} = 2.4\text{V}, I_{ON} = 15\text{mA}$	–	10	15	

**Capacitance** ( $T_A = 25^\circ\text{C}$ ,  $f = 1\text{MHz}$ )

Parameters <sup>(4)</sup>	Description	Test Conditions	Typ	Units
$C_{IN}$	Input Capacitance	$V_{IN} = 0\text{V}$	3	pF
$C_{OFF}$	A/B Capacitance, Switch Off		8.5	
$C_{ON}$	A/B Capacitance, Switch On		17.0	

**Notes:**

- For Max. or Min. conditions, use appropriate value specified under Electrical Characteristics for the applicable device type.
- Typical values are at  $V_{CC} = 3.3\text{V}$ ,  $T_A = 25^\circ\text{C}$  ambient and maximum loading.
- Measured by the voltage drop between A and B pin at indicated current through the switch. On-Resistance is determined by the lower of the voltages on the two (A,B) pins.
- This parameter is determined by device characterization but is not production tested.

### Power Supply Characteristics

Parameters	Description	Test Conditions <sup>(1)</sup>		Min.	Typ <sup>(2)</sup>	Max.	Units
I <sub>CC</sub>	Quiescent Power Supply Current	V <sub>CC</sub> = Max.	V <sub>IN</sub> = GND or V <sub>CC</sub>			10	μA
ΔI <sub>CC</sub>	Supply Current per Input @ TTL HIGH	V <sub>CC</sub> = Max.	V <sub>IN</sub> = 3.0V <sup>(3)</sup>			750	
I <sub>CCD</sub>	Supply Current per Input per MHz <sup>(4)</sup>	V <sub>CC</sub> = Max. A & B Pins Open BE = GND Control Input Toggling 50% Duty Cycle				0.25	mA/ MHz

**Notes:**

1. For Max. or Min. conditions, use appropriate value specified under Electrical Characteristics for the applicable device.
2. Typical values are at V<sub>CC</sub> = 3.3V, +25°C ambient.
3. Per TTL driven input (control inputs only); A and B pins do not contribute to I<sub>cc</sub>.
4. This current applies to the control inputs only and represent the current required to switch internal capacitance at the specified frequency. The A and B inputs generate no significant AC or DC currents as they transition. This parameter is not tested, but is guaranteed by design.

### Switching Characteristics over Operating Range

Parameters	Description	Conditions <sup>(1)</sup>	Com.		Units
			Min.	Max.	
t <sub>PLH</sub> t <sub>PHL</sub>	Bus Enable Time BE to Ax or Bx	C <sub>L</sub> = 50pF R <sub>L</sub> = 500 ohms		0.25	ns
t <sub>PZH</sub> t <sub>PZL</sub>	Bus Enable Time BE to Ax or Bx	C <sub>L</sub> = 50pF R <sub>L</sub> = 500 ohms R = 500 ohms	1	4.5	
t <sub>PHZ</sub> t <sub>PLZ</sub>	Bus Disable Time BE to Ax or Bx		1	5.0	

**Notes:**

1. See test circuit and wave forms.
2. This parameter is guaranteed but not tested on Propagation Delays.
3. The bus switch contributes no propagational delay other than the RC delay of the On-Resistance of the switch and the load capacitance. The time constant for the switch alone is of the order of 0.25ns for 50pF load. Since this time constant is much smaller than the rise/fall times of typical driving signals, it adds very little propagational delay to the system. Propagational delay of the bus switch when used in a system is determined by the driving circuit on the driving side of the switch and its interaction with the load on the driven side.

### Applications Information

#### Logic Inputs

The logic control inputs can be driven up to +3.6 regardless of the supply voltage. For example, given a + 3.3V supply, IN may be driven low to 0V and high to 3.6V. Driving IN Rail-to-Rail® minimizes power consumption.

#### Power-Supply Sequencing and Hot-Plug Information

Proper power-supply sequencing is recommended for all CMOS devices. Always apply V<sub>CC</sub> and GND before applying signals to input/output or control pins.

*Rail-to-Rail is a registered trademark of Nippon Motorola, Ltd*

**Packaging Mechanical: 48-Pin TSSOP (A)**

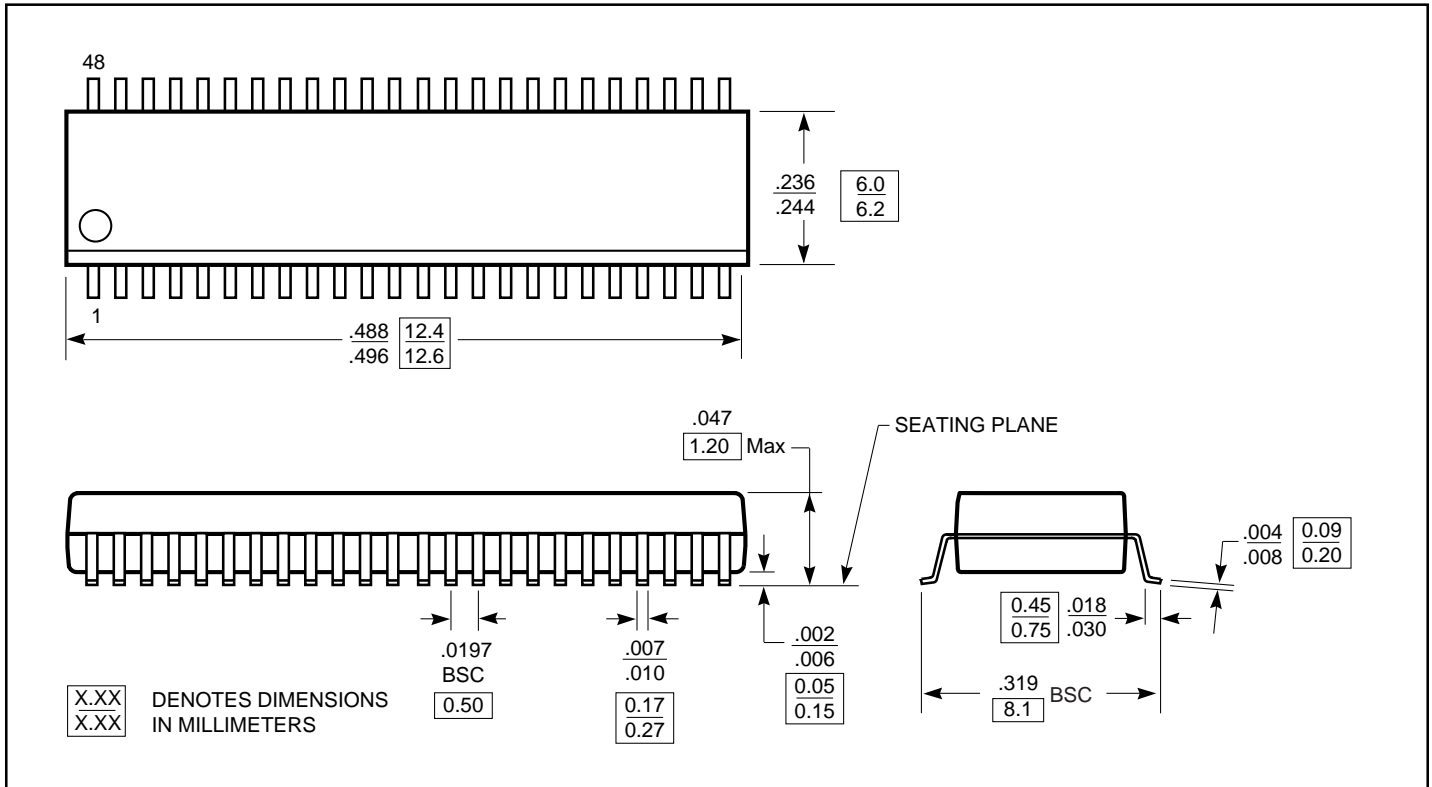

**Packaging Mechanical: 48-Pin SSOP (V)**

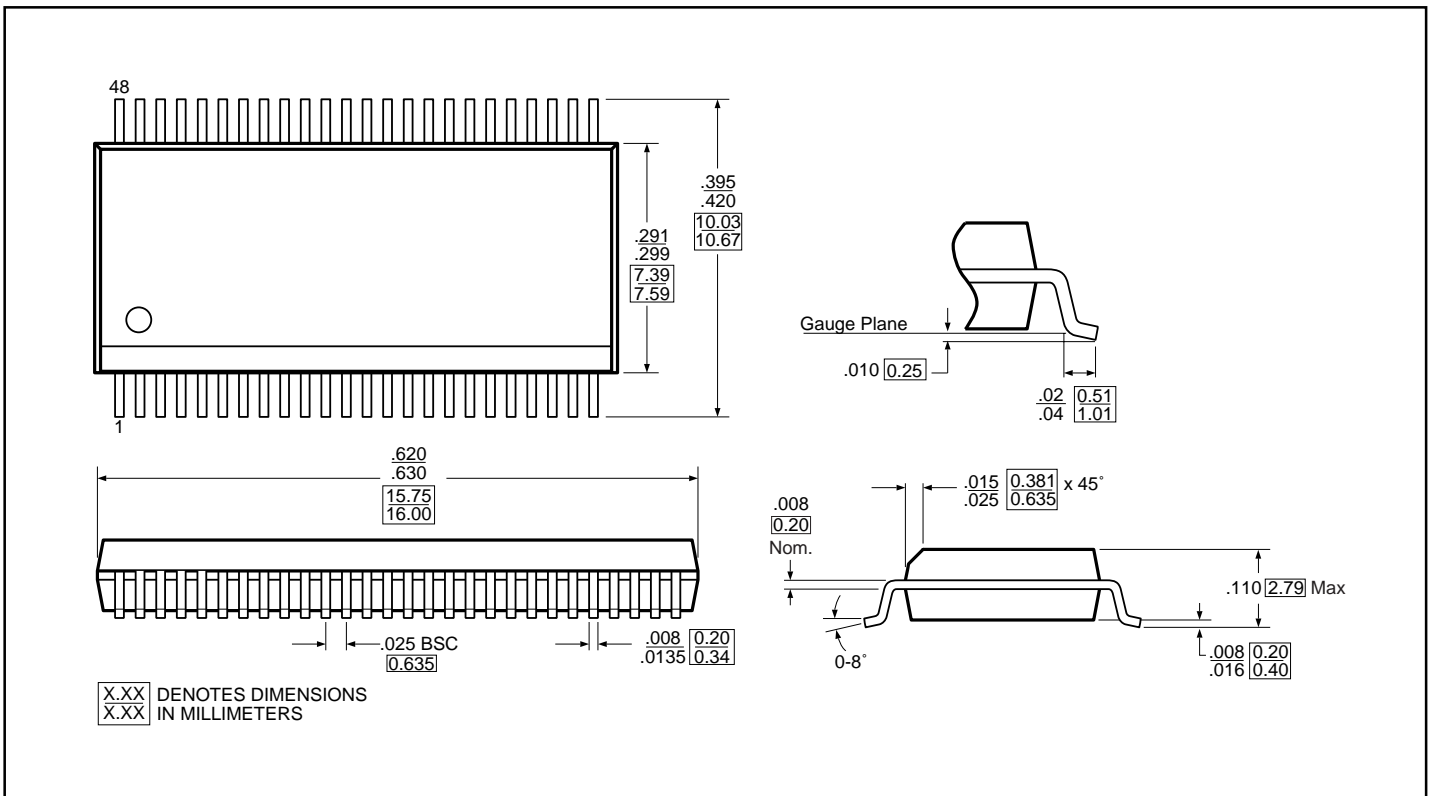

**Packaging Mechanical: 48-Pin BQSOP (B)**

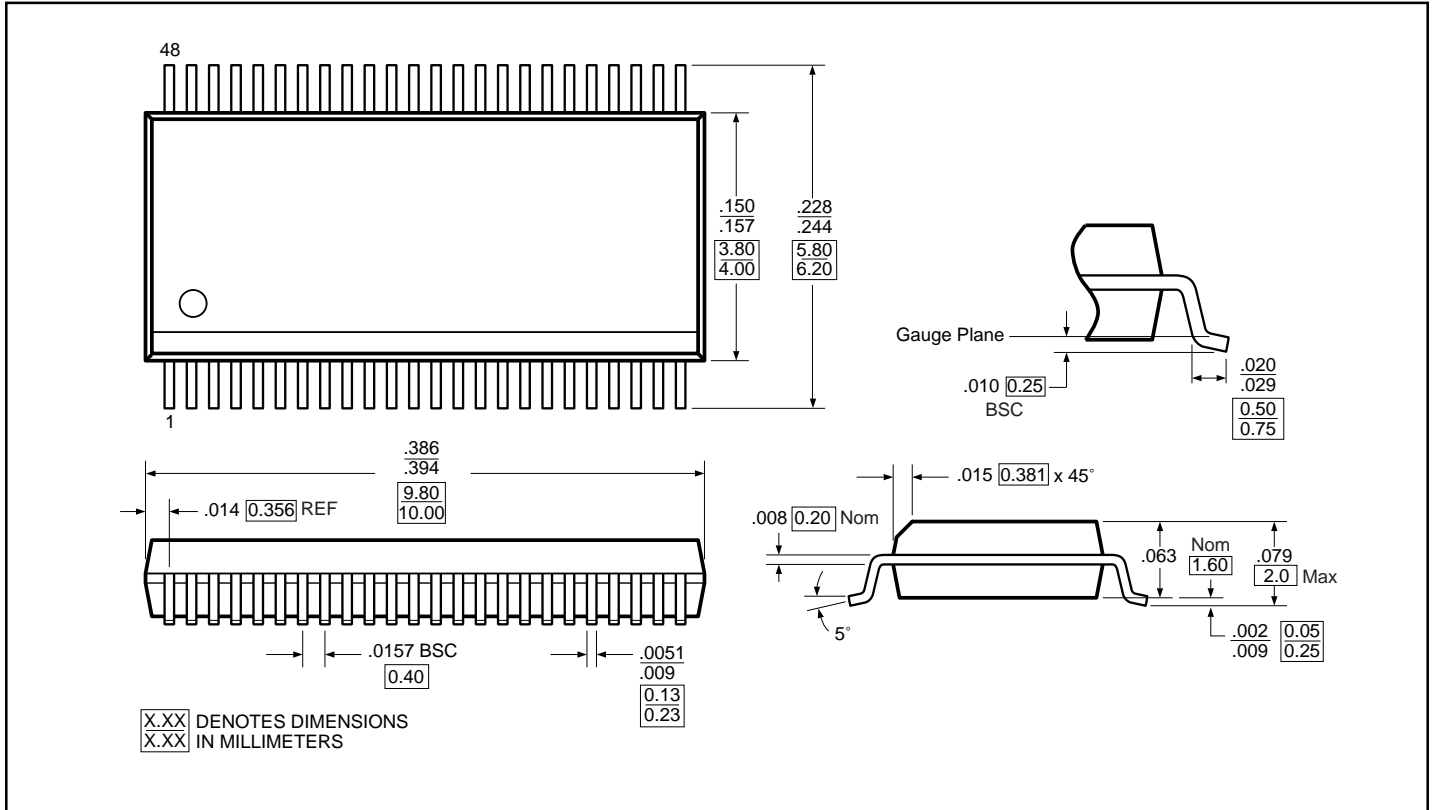

**Ordering Information**



Ordering Code	Package Code	Package Type
PI3B16210A	A	48-pin TSSOP
PI3B16210AE	A	Pb-free & Green, 48-pin TSSOP
PI3B16210V	V	48-pin SSOP
PI3B16210VE	V	Pb-free & Green, 48-pin SSOP
PI3B16210B	B	48-pin BQSOP
PI3B16210BE	B	Pb-free & Green, 48-pin BQSOP

**Notes:**

1. Thermal characteristics can be found on the company web site at [www.pericom.com/packaging/](http://www.pericom.com/packaging/)

## Looking for pricing, stock, or lifecycle information?

Click below to explore more details on WIN SOURCE:

-  [View PI3B16210A on WIN SOURCE](#)
-  [Diodes Incorporated](#) Information

## Optimize Your Supply Chain with WIN SOURCE Solutions

-  Global Sourcing Solution
-  Obsolete Management
-  Cost Control Management
-  Shortage Management
-  Alternative Solution
-  Excess Inventory Management