



**THE DATASHEET OF  
DF11G-30DP-2V(50)**



## TPS92612-Q1 Automotive Single-Channel LED Driver

### 1 Features

- AEC-Q100 Qualified for Automotive Applications
  - Device Temperature Grade 1:  $-40^{\circ}\text{C}$  to  $125^{\circ}\text{C}$ ,  $T_A$
- [Functional safety capable](#)
  - Documentation available to aid functional safety system design
- Single-Channel Constant-Current LED Driver With PWM Dimming
- Wide Input-Voltage Range: 4.5 V–40 V
- Constant Output Current, Adjustable by Sense Resistor
- Precision Current Regulation, Tolerance  $\pm 4.6\%$
- Maximum Current: 150 mA
- Heat Sharing With External Resistor
- Low Dropout Voltage (Current-Sense Voltage Drop Included)
  - Maximum Dropout: 150 mV at 10 mA
  - Maximum Dropout: 400 mV at 70 mA
  - Maximum Dropout: 700 mV at 150 mA
- Low Standby Current ( $<250\ \mu\text{A}$  per Device)
- Protection:
  - LED Short-Circuit Protection With Auto-Recovery
  - Overtemperature Protection
- Operating Junction Temperature Range:  $-40^{\circ}\text{C}$  to  $150^{\circ}\text{C}$

### 2 Applications

- Automotive Convenience Lighting: Dome Light, Door Handles, Reading Lamp, and Miscellaneous Lamps
- Automotive Rear Lamp, Center High-Mounted Stop Lamp, Side Markers, Blind-Spot Detection Indicator, Charging Inlet Indicator
- General-Purpose LED Driver Applications

### 3 Description

With LEDs being widely used in automotive applications, simple LED drivers are more and more popular. Compared to discrete solutions, a low-cost monolithic solution lowers system-level component counts and significantly improves current accuracy and reliability.

The TPS92612-Q1 device is a simple single-channel high-side LED driver operating from an automotive car battery. It is a simple and elegant solution to deliver constant current for a single LED string.

#### Device Information<sup>(1)</sup>

PART NUMBER	PACKAGE	BODY SIZE (NOM)
TPS92612-Q1	SOT-23 (5)	2.9 mm x 1.6 mm

(1) For all available packages, see the orderable addendum at the end of the data sheet.

#### Typical Application Diagram

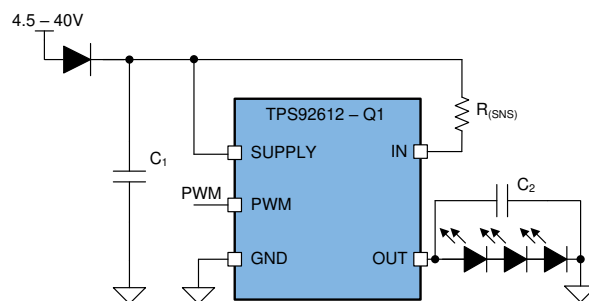

Copyright © 2017, Texas Instruments Incorporated



## Table of Contents

<b>1 Features</b> .....	<b>1</b>	7.4 Device Functional Modes.....	<b>10</b>
<b>2 Applications</b> .....	<b>1</b>	<b>8 Application and Implementation</b> .....	<b>11</b>
<b>3 Description</b> .....	<b>1</b>	8.1 Application Information.....	<b>11</b>
<b>4 Revision History</b> .....	<b>2</b>	8.2 Typical Application .....	<b>11</b>
<b>5 Pin Configuration and Functions</b> .....	<b>3</b>	<b>9 Power Supply Recommendations</b> .....	<b>14</b>
<b>6 Specifications</b> .....	<b>3</b>	<b>10 Layout</b> .....	<b>14</b>
6.1 Absolute Maximum Ratings .....	<b>3</b>	10.1 Layout Guidelines .....	<b>14</b>
6.2 ESD Ratings.....	<b>3</b>	10.2 Layout Example .....	<b>15</b>
6.3 Recommended Operating Conditions.....	<b>4</b>	<b>11 Device and Documentation Support</b> .....	<b>16</b>
6.4 Thermal Information .....	<b>4</b>	11.1 Documentation Support .....	<b>16</b>
6.5 Electrical Characteristics.....	<b>4</b>	11.2 Receiving Notification of Documentation Updates	<b>16</b>
6.6 Timing Requirements .....	<b>5</b>	11.3 Community Resources.....	<b>16</b>
6.7 Typical Characteristics .....	<b>6</b>	11.4 Trademarks .....	<b>16</b>
<b>7 Detailed Description</b> .....	<b>9</b>	11.5 Electrostatic Discharge Caution.....	<b>16</b>
7.1 Overview .....	<b>9</b>	11.6 Glossary .....	<b>16</b>
7.2 Functional Block Diagram .....	<b>9</b>	<b>12 Mechanical, Packaging, and Orderable</b>	<b>16</b>
7.3 Feature Description.....	<b>9</b>	<b>Information</b> .....	<b>16</b>

## 4 Revision History

### Changes from Revision A (July 2018) to Revision B Page

- Added functional safety capable link to the [Features](#) section ..... **1**

### Changes from Original (January 2018) to Revision A Page

- Changed "ambient temperature" to "junction temperature" in the condition statements of the *Absolute Maximum Ratings* and *Recommended Operating Conditions* tables ..... **3**
- Added ESD classification levels for HBM and CDM to the *ESD Ratings* table..... **3**
- Changed rising and falling thresholds ..... **4**
- Added capacitors  $C_1$  and  $C_2$ ..... **11**
- Added capacitors  $C_1$  and  $C_2$ ..... **12**
- Added capacitors  $C_1$  and  $C_2$ ..... **15**

## 5 Pin Configuration and Functions

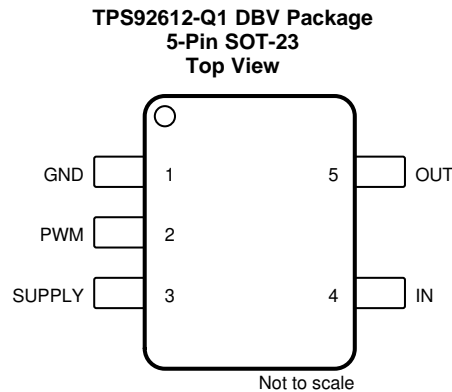

### Pin Functions

PIN		I/O	DESCRIPTION
NAME	NO. TPS92612-Q1		
GND	1	—	Ground
IN	4	I	Current input
OUT	5	O	Constant-current output
PWM	2	I	PWM input
SUPPLY	3	I	Device supply voltage

## 6 Specifications

### 6.1 Absolute Maximum Ratings

over operating junction temperature range (unless otherwise noted)<sup>(1)</sup>

		MIN	MAX	UNIT
High-voltage input	IN, PWM, SUPPLY	−0.3	45	V
High-voltage output	OUT	−0.3	45	V
IN to OUT	$V_{(IN)} - V_{(OUT)}$	−0.3	45	V
SUPPLY to IN	$V_{(SUPPLY)} - V_{(IN)}$	−0.3	1	V
Operating junction temperature, $T_J$		−40	150	°C
Storage temperature, $T_{stg}$		−40	150	°C

(1) Stresses beyond those listed under *Absolute Maximum Ratings* may cause permanent damage to the device. These are stress ratings only, which do not imply functional operation of the device at these or any other conditions beyond those indicated under *Recommended Operating Conditions*. Exposure to absolute-maximum-rated conditions for extended periods may affect device reliability.

### 6.2 ESD Ratings

			VALUE	UNIT
$V_{(ESD)}$	Electrostatic discharge	Human-body model (HBM), per AEC Q100-002 <sup>(1)</sup> HBM ESD Classification Level 2	±2000	V
		Charged-device model (CDM), per AEC Q100-011 CDM ESD Classification Level C3B [There isn't a C3B classification, unless there is a mistake in STDZ0171 on page 84.]	±500	
		Corner pins (3, 4, and 5)	±750	

(1) AEC Q100-002 indicates that HBM stressing shall be in accordance with the ANSI/ESDA/JEDEC JS-001 specification.

### 6.3 Recommended Operating Conditions

over operating junction temperature range (unless otherwise noted)

		MIN	NOM	MAX	UNIT
SUPPLY	Device supply voltage	4.5		40	V
IN	Sense voltage	4.4		40	V
PWM	PWM inputs	0		40	V
OUT	Driver output	0		40	V
T <sub>A</sub>	Operating ambient temperature	–40		125	°C

### 6.4 Thermal Information

THERMAL METRIC <sup>(1)</sup>		TPS92612-Q1	UNIT
		DBV (SOT23)	
		5 PINS	
R <sub>θJA</sub>	Junction-to-ambient thermal resistance	200.7	°C/W
R <sub>θJC(top)</sub>	Junction-to-case (top) thermal resistance	104.4	°C/W
R <sub>θJB</sub>	Junction-to-board thermal resistance	45.6	°C/W
ψ <sub>JT</sub>	Junction-to-top characterization parameter	17.5	°C/W
ψ <sub>JB</sub>	Junction-to-board characterization parameter	45.2	°C/W

 (1) For more information about traditional and new thermal metrics, see [Semiconductor and IC Package Thermal Metrics](#).

### 6.5 Electrical Characteristics

 V<sub>(SUPPLY)</sub> = 5 V to 40 V, T<sub>J</sub> = –40°C to 150°C unless otherwise noted

PARAMETER		TEST CONDITIONS	MIN	TYP	MAX	UNIT
<b>BIAS</b>						
V <sub>(POR_rising)</sub>	Supply voltage POR rising threshold			3.2	4	V
V <sub>(POR_falling)</sub>	Supply voltage POR falling threshold		2.2	3		V
I <sub>(Quiescent)</sub>	Device standby current	PWM = LOW	0.1	0.2	0.25	mA
<b>LOGIC INPUTS (PWM)</b>						
V <sub>IL(PWM)</sub>	Input logic-low voltage, PWM		1.045	1.1	1.155	V
V <sub>IH(PWM)</sub>	Input logic-high voltage, PWM		1.14	1.2	1.26	V
<b>CONSTANT-CURRENT DRIVER</b>						
I <sub>(OUT)</sub>	Device output-current range	100% duty cycle	4		150	mA
V <sub>(CS_REG)</sub>	Sense-resistor regulation voltage	T <sub>A</sub> = 25°C, V <sub>(SUPPLY)</sub> = 4.5 V to 18 V	94	98	102	mV
		T <sub>A</sub> = –40°C to 125°C, V <sub>(SUPPLY)</sub> = 4.5 V to 18 V	93.5	98	102.5	
R <sub>(CS_REG)</sub>	Sense-resistor value				24.5	Ω
V <sub>(DROPOUT)</sub>	Voltage dropout from SUPPLY to OUT	V <sub>(CS_REG)</sub> voltage included, current setting = 10 mA		120	150	mV
		V <sub>(CS_REG)</sub> voltage included, current setting = 70 mA		250	400	
		V <sub>(CS_REG)</sub> voltage included, current setting = 150 mA		430	700	
<b>DIAGNOSTICS</b>						
V <sub>(SG_th_falling)</sub>	Channel output V <sub>(OUT)</sub> short-to-ground falling threshold		1.14	1.2	1.26	V
V <sub>(SG_th_rising)</sub>	Channel output V <sub>(OUT)</sub> short-to-ground rising threshold		0.82	0.865	0.91	V
I <sub>(Retry)</sub>	Channel output V <sub>(OUT)</sub> short-to-ground retry current	V <sub>(OUT)</sub> = 0 V	0.64	1.08	1.528	mA

**Electrical Characteristics (continued)**

$V_{(SUPPLY)} = 5\text{ V to }40\text{ V}$ ,  $T_J = -40^\circ\text{C to }150^\circ\text{C}$  unless otherwise noted

PARAMETER		TEST CONDITIONS	MIN	TYP	MAX	UNIT
<b>THERMAL PROTECTION</b>						
$T_{(TSD)}$	Thermal shutdown junction temperature threshold			172		$^\circ\text{C}$
$T_{(TSD\_HYS)}$	Thermal shutdown junction temperature hysteresis			15		$^\circ\text{C}$

**6.6 Timing Requirements**

		MIN	NOM	MAX	UNIT
$t_{(PWM\_delay\_rising)}$	PWM rising edge delay, 50% PWM voltage to 10% of output current, $t_2 - t_1$ as shown in Figure 1		17		$\mu\text{s}$
$t_{(PWM\_delay\_falling)}$	PWM falling edge delay, 50% PWM voltage to 90% of output current, $t_5 - t_4$ as shown in Figure 1		21		$\mu\text{s}$
$t_{(TSD\_deg)}$	Thermal overtemperature deglitch time		60		$\mu\text{s}$
$t_{(SG\_deg)}$	Channel-output short-to-ground detection deglitch time	80	125	175	$\mu\text{s}$
$t_{(Recover\_deg)}$	Recovery deglitch time		16		$\mu\text{s}$

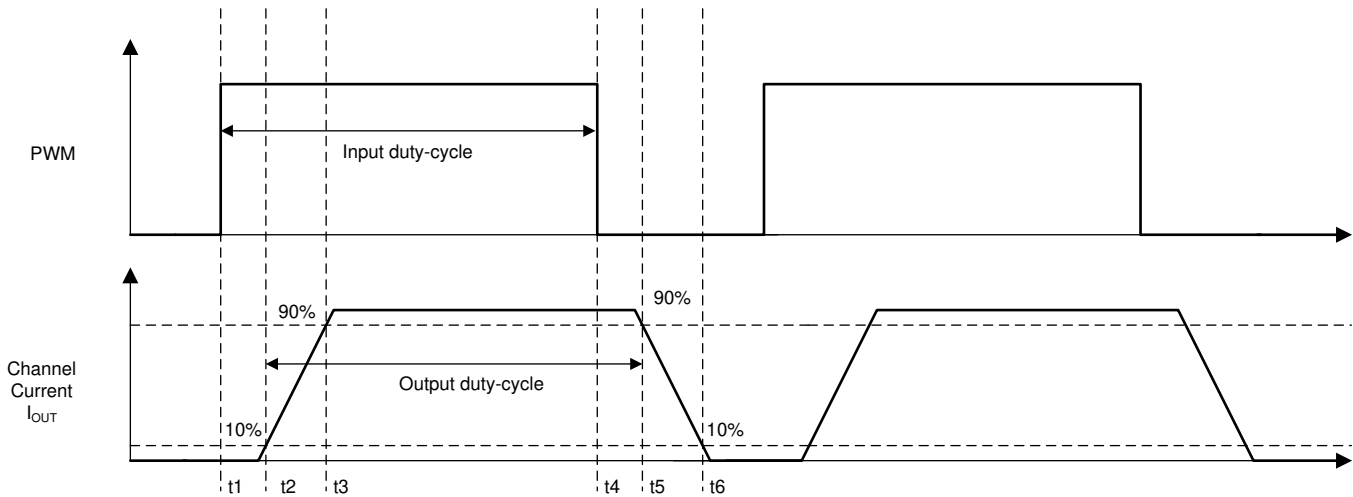

Copyright © 2017, Texas Instruments Incorporated

**Figure 1. Output Timing Diagram**

## 6.7 Typical Characteristics

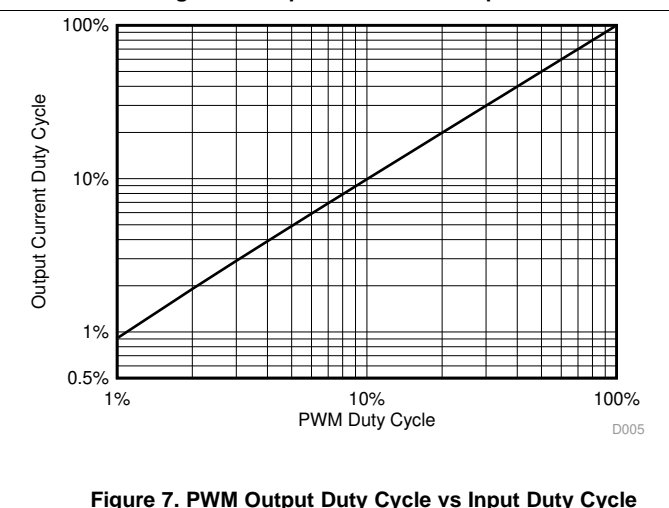
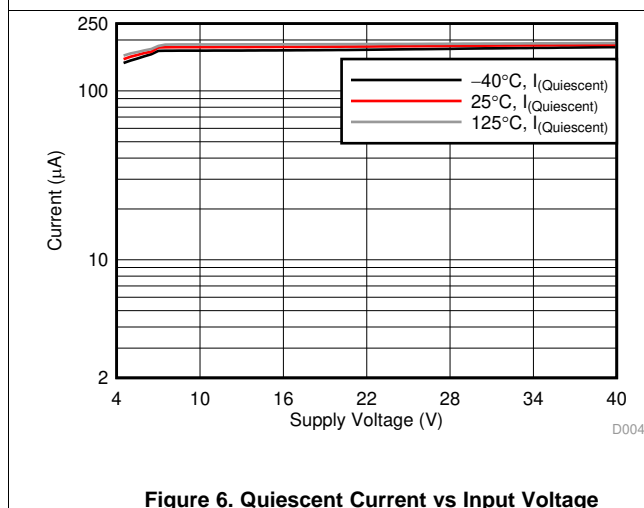
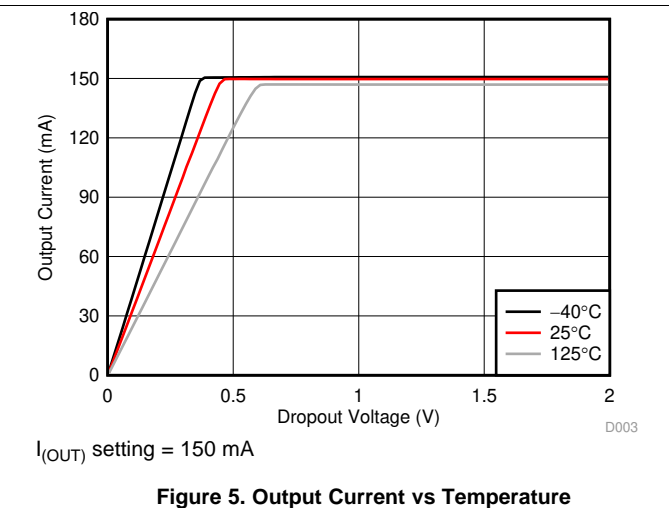
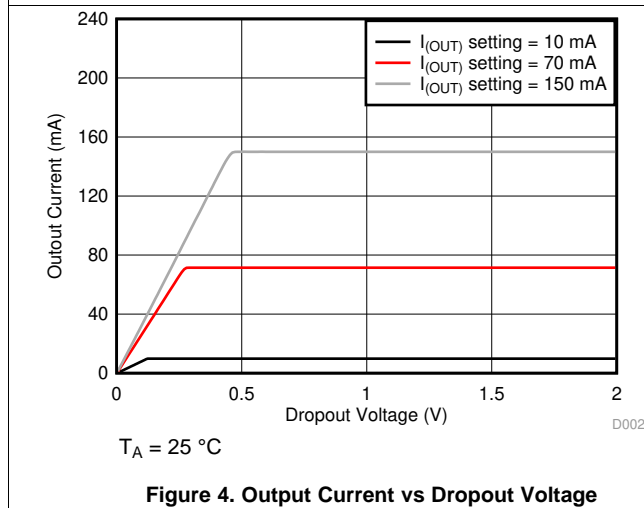
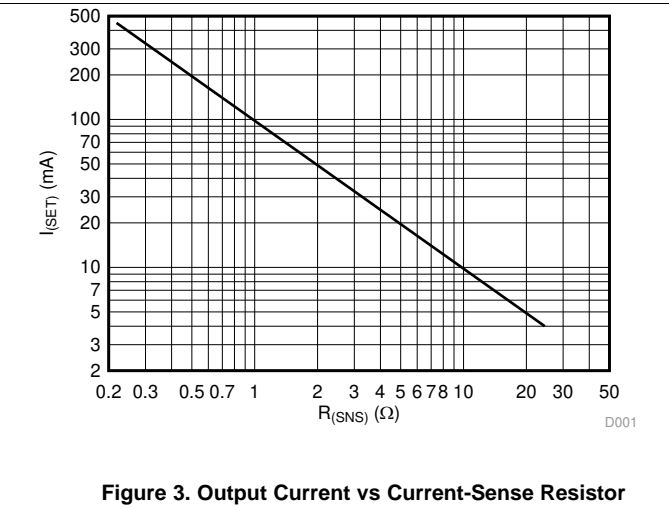
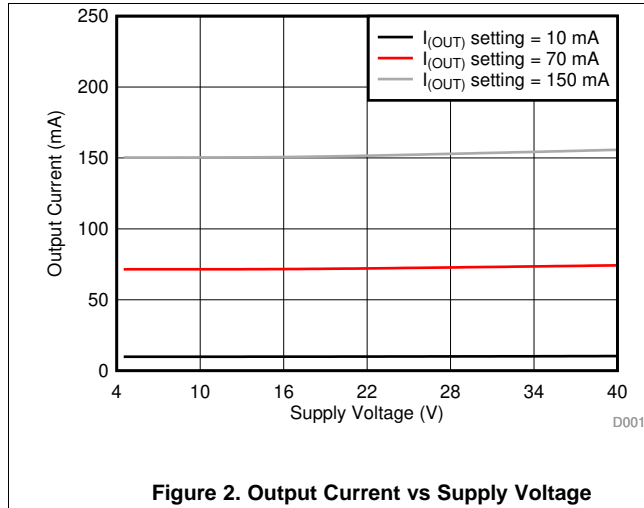

Typical Characteristics (continued)

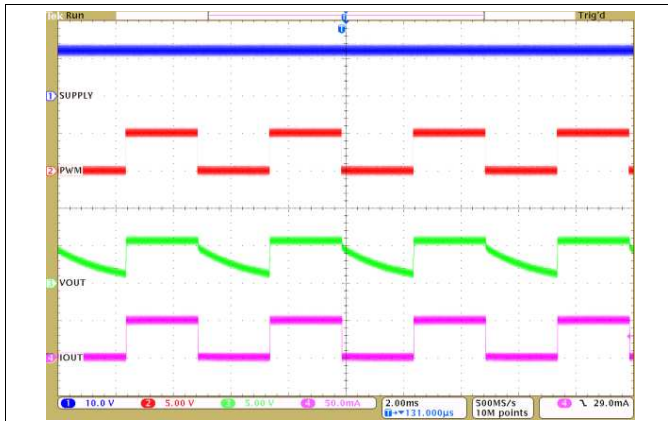

Ch. 1 =  $V_{(SUPPLY)}$  Ch. 2 =  $V_{(PWM)}$  Ch. 3 =  $I_{(OUT)}$   
 Ch. 4 =  $V_{(OUT)}$   $f_{(PWM)} = 200 \text{ Hz}$  Duty-cycle = 50%

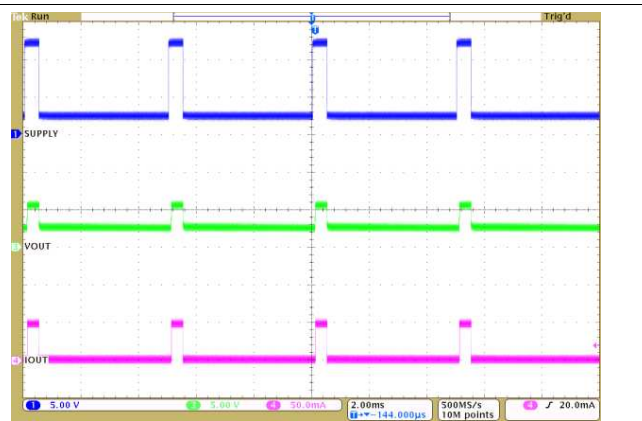

Ch. 1 =  $V_{(SUPPLY)}$  Ch. 3 =  $V_{(OUT)}$  Ch. 4 =  $I_{(OUT)}$   
 $f_{(PWM)} = 200 \text{ Hz}$  Duty-cycle = 10%  
 SUPPLY dimming between 2.5 V and 12 V

Figure 8. PWM Dimming via External Input

Figure 9. PWM Dimming via Power Supply

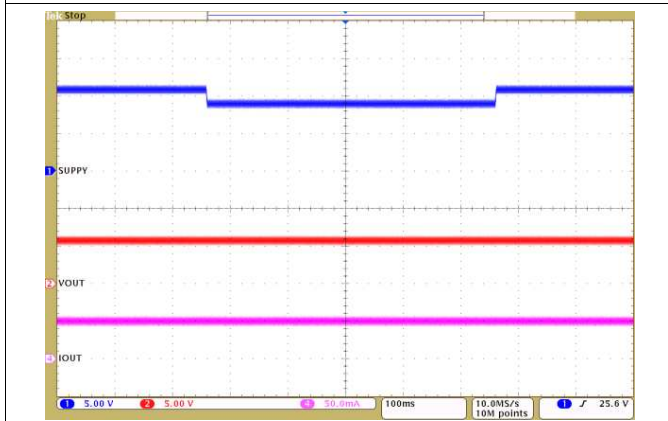

Ch. 1 = SUPPLY Ch. 2 =  $V_{(OUT)}$  Ch. 4 =  $I_{(OUT)}$

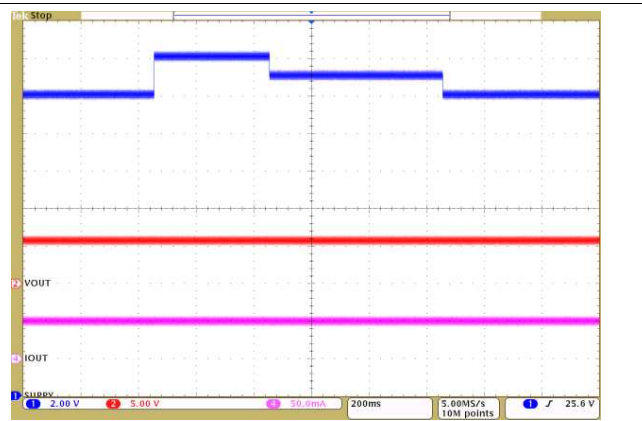

Ch. 1 = SUPPLY Ch. 2 =  $V_{(OUT)}$  Ch. 4 =  $I_{(OUT)}$

Figure 10. Transient Undervoltage

Figure 11. Transient Overvoltage

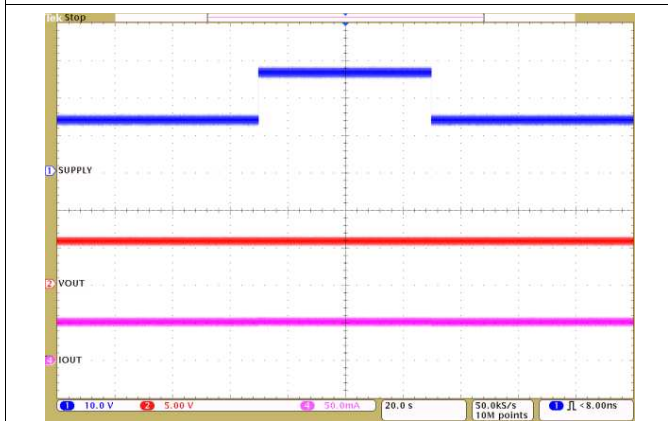

Ch. 1 = SUPPLY Ch. 2 =  $V_{(OUT)}$  Ch. 4 =  $I_{(OUT)}$

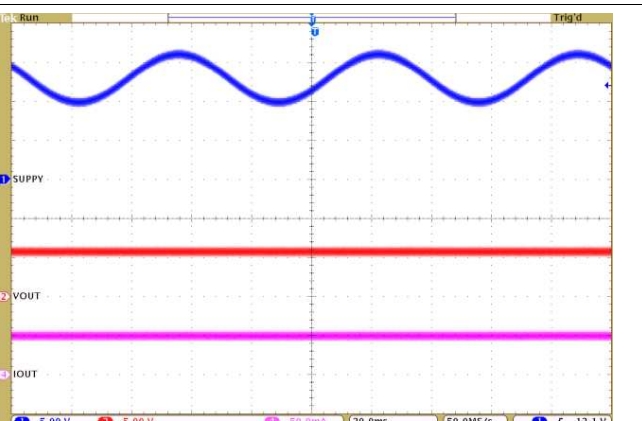

Ch. 1 = SUPPLY Ch. 2 =  $V_{(OUT)}$  Ch. 4 =  $I_{(OUT)}$

Figure 12. Jump Start

Figure 13. Superimposed Alternating Voltage, 15 Hz

Typical Characteristics (continued)

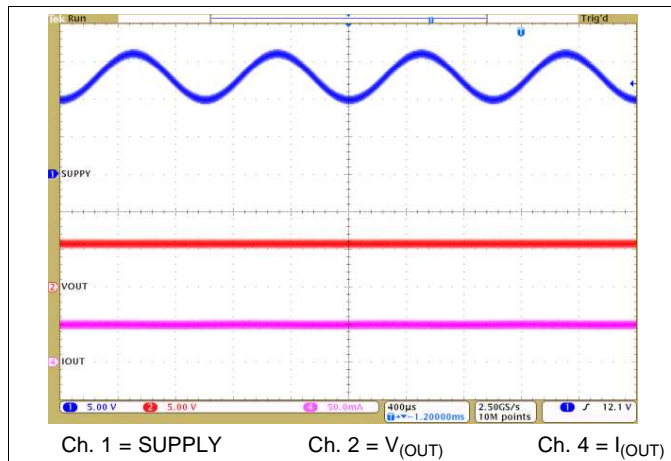

Figure 14. Superimposed Alternating Voltage, 1kHz

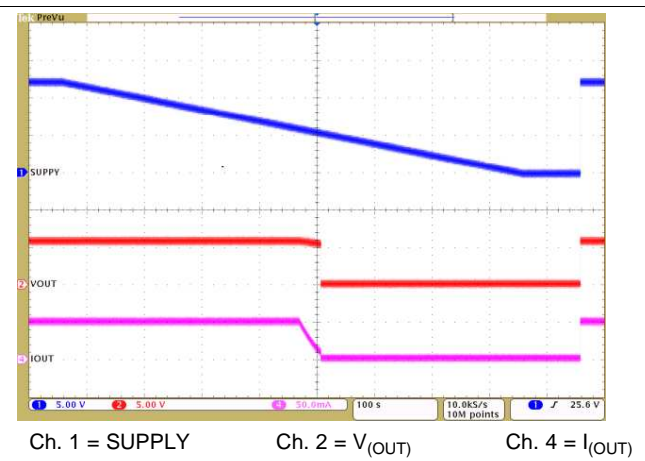

Figure 15. Slow Decrease, Quick Increase of Supply Voltage

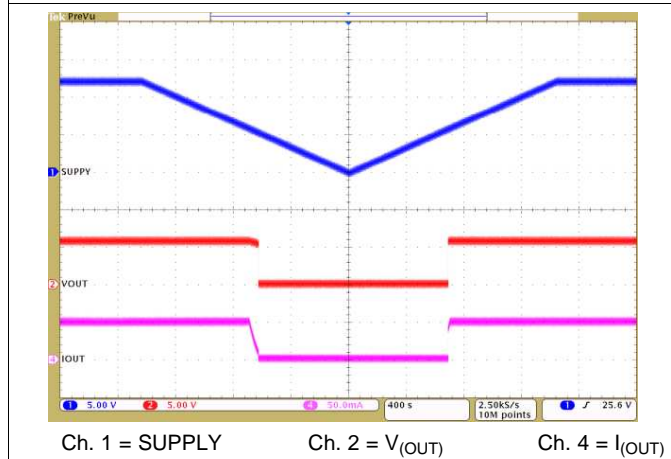

Figure 16. Slow Decrease and Slow Increase of Supply Voltage

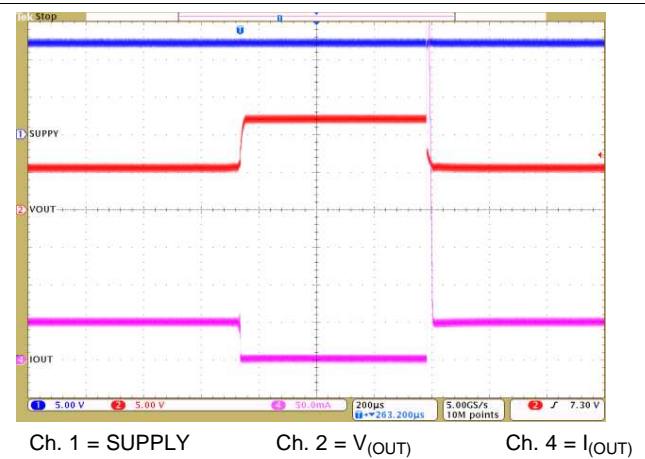

Figure 17. LED Open-Circuit and Recovery

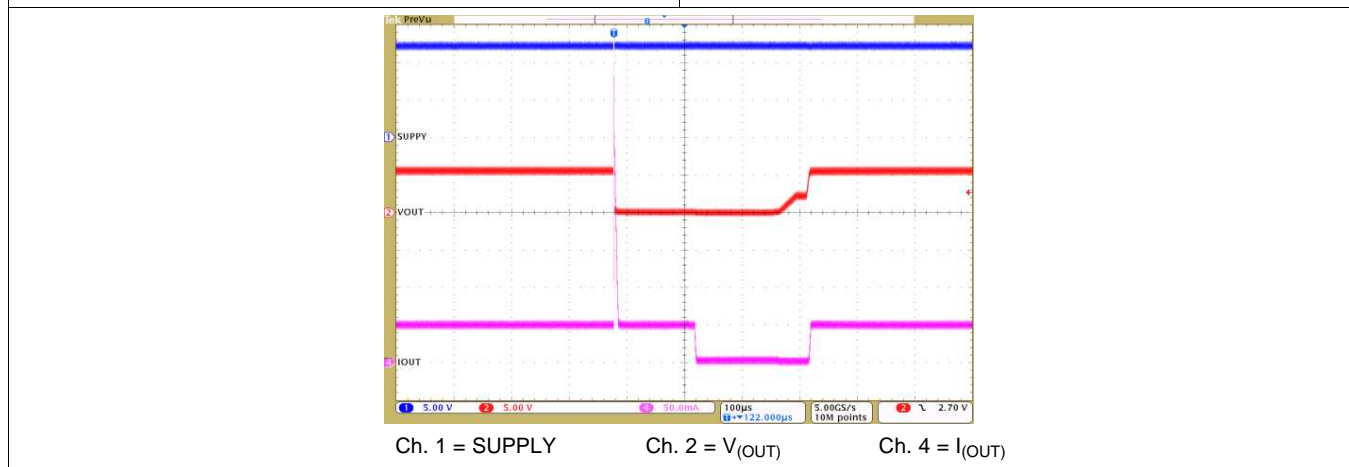

Figure 18. LED Short-Circuit Protection and Recovery

## 7 Detailed Description

### 7.1 Overview

The TPS92612-Q1 device is the one of a family of single-channel linear LED drivers. The device provides a simple current source with protection for automotive LED applications.

The output current can be set by an external  $R_{(SNS)}$  resistor. Current flows from the supply through the  $R_{(SNS)}$  resistor into the internal current source and to the LEDs.

### 7.2 Functional Block Diagram

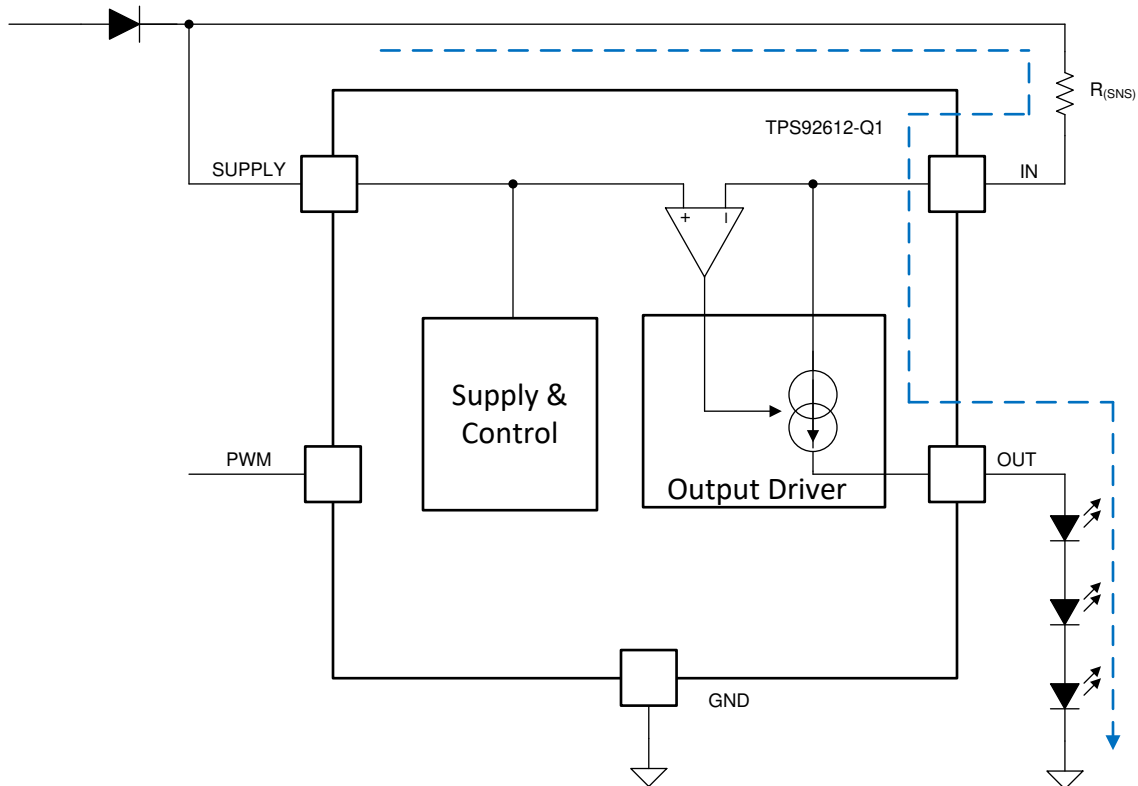

Copyright ©2017, Texas Instruments Incorporated

### 7.3 Feature Description

#### 7.3.1 Device Bias

##### 7.3.1.1 Power-On Reset (POR)

The TPS92612-Q1 device has an internal power-on-reset (POR) function. When power is applied to SUPPLY, the internal POR holds the device in the reset condition until  $V_{(SUPPLY)}$  reaches  $V_{(POR\_rising)}$ .

##### 7.3.2 Constant-Current Driver

The TPS92612-Q1 device has a high-side constant-current integrated driver. The device senses channel current with an external high-side current-sense resistor,  $R_{(SNS)}$ . A current regulation loop drives an internal transistor and regulates the current-sense voltage at the current-sense resistor to  $V_{(CS\_REG)}$ . When the output driver is in regulation, the output current can be set by the current-sense resistor using the following equation.

$$I_{(OUT)} = \frac{V_{(CS\_REG)}}{R_{(SNS)}} \quad (1)$$

## Feature Description (continued)

### 7.3.3 PWM Dimming

The TPS92612-Q1 device supports PWM dimming via PWM input dimming and supply dimming.

The PWM input functions as an enable for the output current.

Supply dimming applies PWM dimming on the power input. For an accurate PWM threshold, TI recommends using a resistor divider on the PWM input stage to set the PWM threshold higher than  $V_{(POR\_rising)}$ .

### 7.3.4 Protection

#### 7.3.4.1 Short-to-GND Protection

The TPS92612-Q1 device has LED short-to-GND protection. Short-to-GND detection monitors the output voltage when the channel is in the ON state. Once a short-to-GND LED failure is detected, the device turns off the output channel and retries automatically, ignoring the PWM input. If the retry mechanism detects removal of the LED short-to-GND fault, the device resumes normal operation.

The device monitors the  $V_{(OUT)}$  voltage and compares it with the internal reference voltage to detect a short-to-GND failure. If  $V_{(OUT)}$  falls below  $V_{(SG\_th\_rising)}$  longer than the deglitch time of  $t_{(SG\_deg)}$ , the device asserts the short-to-GND fault. During the deglitching time period, if  $V_{(OUT)}$  rises above  $V_{(SG\_th\_falling)}$ , the timer is reset.

Once the device has detected a short-to-GND fault, the device turns off the output channel and retries automatically with a small current. When retrying, the device sources a small current  $I_{(retry)}$  from IN to OUT to pull up the LED loads continuously. Once auto retry detects output voltage rising above  $V_{(SG\_th\_falling)}$ , the device clears the short-to-GND fault and resumes normal operation.

#### 7.3.4.2 Overtemperature Protection

The TPS92612-Q1 device monitors device junction temperature. When the junction temperature reaches thermal shutdown threshold  $T_{(TSD)}$ , the output shuts down. Once the junction temperature falls below  $T_{(TSD)} - T_{(TSD\_HYS)}$ , the device resumes normal operation.

## 7.4 Device Functional Modes

### 7.4.1 Undervoltage Lockout, $V_{(SUPPLY)} < V_{(POR\_rising)}$

When the device is in undervoltage lockout mode, the TPS92612-Q1 device disables all functions until the supply rises above the POR-rising threshold.

### 7.4.2 Normal Operation, $V_{(SUPPLY)} \geq 4.5\text{ V}$

The device drives an LED string in normal operation. With enough voltage drop across SUPPLY and OUT, the device is able to drive the output in constant-current mode.

## 8 Application and Implementation

### NOTE

Information in the following applications sections is not part of the TI component specification, and TI does not warrant its accuracy or completeness. TI's customers are responsible for determining suitability of components for their purposes. Customers should validate and test their design implementation to confirm system functionality.

### 8.1 Application Information

In automotive lighting applications, thermal performance is always a design challenge for linear LED drivers.

To increase current-driving capability, the TPS92612-Q1 device supports heat sharing using an external parallel resistor as shown in Figure 21. This technique provides the low-cost solution of using external resistors to dissipate heat due to high input voltage, and still keeps high accuracy of the total current output.

### 8.2 Typical Application

#### 8.2.1 Single-Channel LED Driver

The TPS92612-Q1 device can be a good fit for many automotive lighting applications.

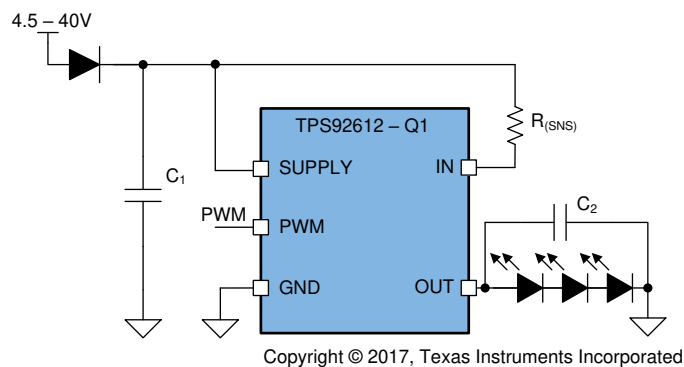

Figure 19. Typical Application Diagram

##### 8.2.1.1 Design Requirements

Input voltage range is 9 V to 16 V, LED maximum forward voltage  $V_{fmax} = 2.5$  V, minimum forward voltage  $V_{fmin} = 1.9$  V, current  $I_{(LED)} = 50$  mA.

##### 8.2.1.2 Detailed Design Procedure

Current setting by the sense resistor is as described in Equation 1.

$$R_{(SNS)} = \frac{V_{(CS\_REG)}}{I_{(LED)}} = 1.96\Omega \quad (2)$$

LED-string maximum forward voltage =  $3 \times 2.5$  V = 7.5 V.

Total device power consumption at worst case is with 16-V input and LEDs at minimal forward voltage.

$$\begin{aligned} P_{(Max)} &= (V_{(SUPPLY)} - V_{(CS\_REG)} - V_{(OUT)}) \times I_{(LED)} + V_{(SUPPLY)} \times I_{(Quiescent)} \\ &= (16 - 3 \times 1.9 - 0.098) \times 0.05 + 16 \times 0.00025 = 0.5141 \text{ W} \end{aligned} \quad (3)$$

TI recommends to add capacitors  $C_1$  and  $C_2$  at SUPPLY and OUT. TI recommends  $C_1$  of 1  $\mu$ F and 100 nF close to the SUPPLY pin, and  $C_2$  of 10 nF close to the OUT pin. A larger capacitor for  $C_1$  or  $C_2$  is helpful for EMC and ESD; however, it takes a longer time to charge up the capacitor and could affect PWM dimming performance.

## Typical Application (continued)

### 8.2.1.3 Application Curve

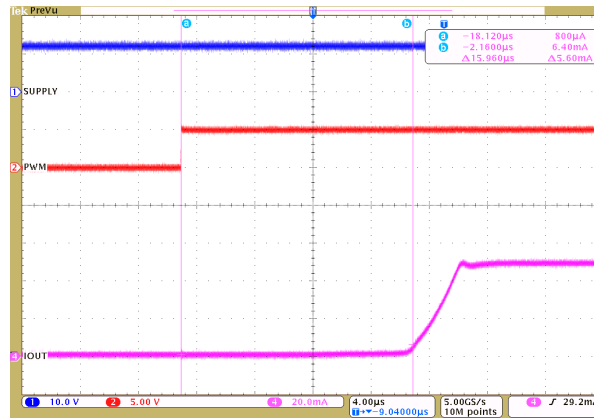

Ch. 1 =  $V_{(OUT)}$     Ch. 2 =  $V_{(PWM)}$     Ch. 4 =  $I_{(OUT)}$

Figure 20. Output Current With PWM Input

### 8.2.2 Single-Channel LED Driver With Heat Sharing

Using parallel resistors, thermal performance can be improved by balancing current between the TPS92612-Q1 device and the external resistors as follows. As the current-sense resistor controls the total LED string current, the LED string current  $I_{(LED)}$  is set by  $V_{(CS\_REG)} / R_{(SNS)}$ , while the TPS92612-Q1 current  $I_{(DRIVE)}$  and parallel resistor current  $I_{(P)}$  combine to the total current.

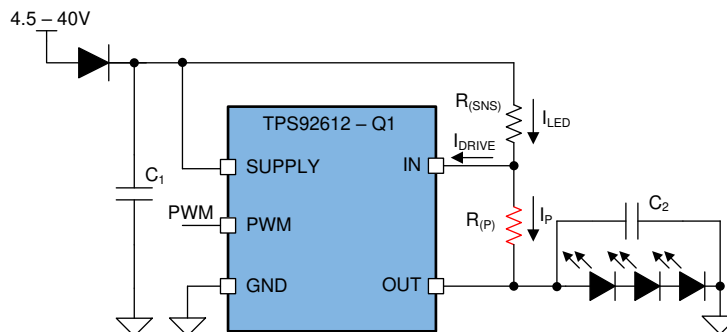

Figure 21. Heat Sharing With a Parallel Resistor

#### 8.2.2.1 Design Requirements

The input voltage range is 9 V to 16 V, LED maximum forward voltage  $V_{fmax} = 2.5$  V, minimum forward voltage  $V_{fmin} = 1.9$  V, current  $I_{(LED)} = 100$  mA.

#### 8.2.2.2 Detailed Design Procedure

In linear LED driver applications, the input voltage variation contributes to most of the thermal concerns. The resistor current, as indicated by Ohm's law, depends on the voltage across the external resistors. The TPS92612-Q1 device controls the driver current  $I_{(DRIVE)}$  to attain the desired total current. If  $I_{(P)}$  increases, the TPS92612-Q1 device decreases  $I_{(DRIVE)}$  to compensate, and vice versa.

While in low-dropout mode, the voltage across the  $R_{(P)}$  resistor may be close to zero, so that almost no current can flow through the external resistor  $R_{(P)}$ .

## Typical Application (continued)

When the input voltage is high, parallel-resistor current  $I_{(P)}$  is proportional to the voltage across the parallel resistor,  $R_{(P)}$ . The parallel resistor,  $R_{(P)}$ , takes the majority of the total string current, generating maximum heat. The device must prevent current from draining out to ensure current regulation capability.

In this case, the parallel resistor value must be carefully calculated to ensure that 1) enough output current is achieved in low-dropout mode, 2) thermal dissipation for both the TPS92612-Q1 device and the resistor is within their thermal dissipation limits, and 3) device current in the high-voltage mode is above the minimal output-current requirement.

TI recommends to add capacitors  $C_1$  and  $C_2$  at SUPPLY and OUT. TI recommends  $C_1$  of 1  $\mu$ F and 100 nF close to the SUPPLY pin, and  $C_2$  of 10 nF close to the OUT pin. A larger capacitor for  $C_1$  or  $C_2$  is helpful for EMC and ESD; however, it takes a longer time to charge up the capacitor and could affect PWM dimming performance.

Current setting by the sense resistor is as described in [Equation 1](#).

$$R_{(SNS)} = \frac{V_{(CS\_REG)}}{I_{(LED)}} = 0.98\Omega \quad (4)$$

LED-string maximum forward voltage =  $3 \times 2.5 \text{ V} = 7.5 \text{ V}$ .

Parallel resistor  $R_{(P)}$  is recommended to consume 1/2 of the total current at maximum supply voltage.

$$R_{(P)} = \frac{V_{(SUPPLY)} - V_{(CS\_REG)} - V_{(OUT)}}{0.5 \times I_{(LED)}} = \frac{16 - 0.098 - 3 \times 1.9}{0.5 \times 0.1} \approx 200\Omega \quad (5)$$

Total device power consumption is maximum with 16-V input and LEDs at minimal forward voltage.

$$\begin{aligned} P_{(DEV\_MAX)} &= \left( V_{(SUPPLY)} - V_{(CS\_REG)} - V_{(OUT)} \right) \times \left( I_{(LED)} - \frac{V_{(SUPPLY)} - V_{(CS\_REG)} - V_{(OUT)}}{R_{(P)}} \right) + V_{(SUPPLY)} \times I_{(Quiescent)} \\ &= (16 - 0.098 - 3 \times 1.9) \times \left( 0.1 - \frac{16 - 0.098 - 3 \times 1.9}{200} \right) + 16 \times 0.00025 = 0.504\text{W} \end{aligned} \quad (6)$$

Resistor  $R_{(P)}$  maximum power consumption is at 16-V input.

$$P_{(RP\_MAX)} = \frac{\left( V_{(SUPPLY)} - V_{(CS\_REG)} - V_{(OUT)} \right)^2}{R_{(P)}} = \frac{(16 - 0.098 - 3 \times 1.9)^2}{200} = 0.52\text{W} \quad (7)$$

## Typical Application (continued)

### 8.2.2.3 Application Curve

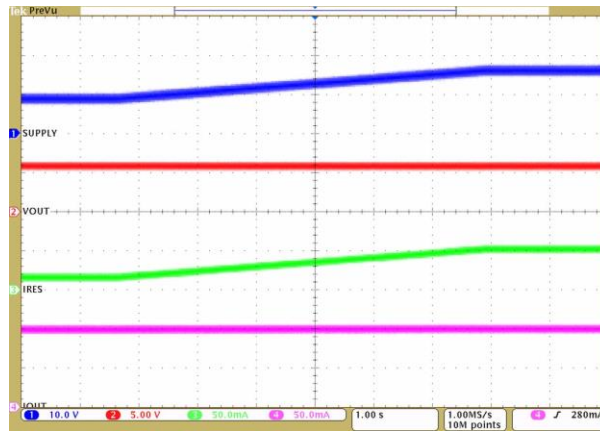

Ch. 1 =  $V_{\text{SUPPLY}}$       Ch. 2 =  $V_{\text{OUT}}$       Ch. 3 =  $I_{\text{P}}$

Ch. 4 =  $I_{\text{LED}}$

Supply voltage increases from 9 V to 16 V

**Figure 22. Constant Output Current With Increasing Supply Voltage**

## 9 Power Supply Recommendations

The TPS92612-Q1 device is qualified for automotive applications. The normal power supply connection is therefore to an automobile electrical system that provides a voltage within the range specified in the [Recommended Operating Conditions](#).

## 10 Layout

### 10.1 Layout Guidelines

Thermal dissipation is the primary consideration for TPS92612-Q1 layout. TI recommends good thermal dissipation area beneath the device for better thermal performance.

## 10.2 Layout Example

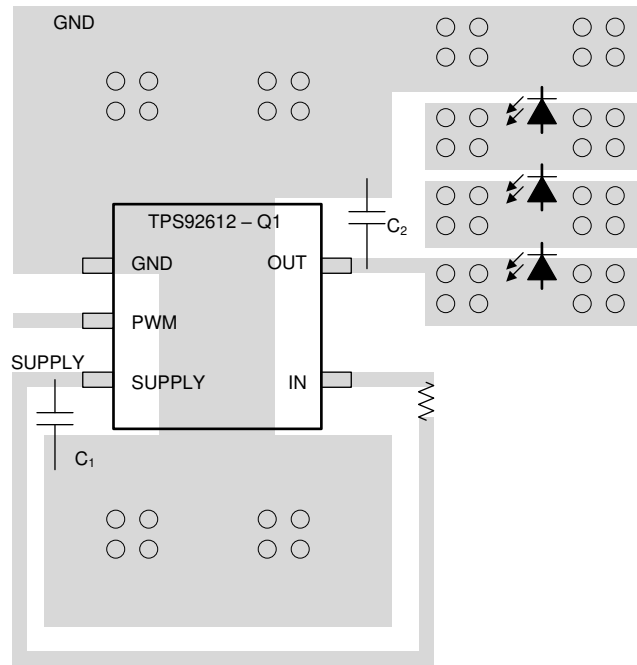

**Figure 23. TPS92612-Q1 Example Layout Diagram**

## 11 Device and Documentation Support

### 11.1 Documentation Support

#### 11.1.1 Related Documentation

For related documentation see the following:

- [TPS92610-Q1 Automotive Single-Channel Linear LED Driver](#)
- [TPS92611-Q1 Automotive Single-Channel Linear LED Driver](#)
- [TPS92610-Q1 EVM User's Guide](#)
- [How to Calculate TPS92630-Q1 Maximum Output Current for Automotive Exterior Lighting Applications](#)
- [Automotive Linear LED Driver Reference Design for Center High-Mounted Stop Lamp \(CHMSL\)](#)
- [Automotive Linear LED Driver Reference Design for Center High-Mounted Stop Lamp \(CHMSL\)](#)

#### 11.2 Receiving Notification of Documentation Updates

To receive notification of documentation updates, navigate to the device product folder on ti.com. In the upper right corner, click on *Alert me* to register and receive a weekly digest of any product information that has changed. For change details, review the revision history included in any revised document.

#### 11.3 Community Resources

[TI E2E™ support forums](#) are an engineer's go-to source for fast, verified answers and design help — straight from the experts. Search existing answers or ask your own question to get the quick design help you need.

Linked content is provided "AS IS" by the respective contributors. They do not constitute TI specifications and do not necessarily reflect TI's views; see TI's [Terms of Use](#).

#### 11.4 Trademarks

E2E is a trademark of Texas Instruments.

All other trademarks are the property of their respective owners.

#### 11.5 Electrostatic Discharge Caution



This integrated circuit can be damaged by ESD. Texas Instruments recommends that all integrated circuits be handled with appropriate precautions. Failure to observe proper handling and installation procedures can cause damage.

ESD damage can range from subtle performance degradation to complete device failure. Precision integrated circuits may be more susceptible to damage because very small parametric changes could cause the device not to meet its published specifications.

#### 11.6 Glossary

[SLYZ022](#) — *TI Glossary*.

This glossary lists and explains terms, acronyms, and definitions.

## 12 Mechanical, Packaging, and Orderable Information

The following pages include mechanical, packaging, and orderable information. This information is the most-current data available for the designated device. This data is subject to change without notice and without revision of this document. For browser-based versions of this data sheet, see the left-hand navigation pane.

**PACKAGING INFORMATION**

Orderable Device	Status (1)	Package Type	Package Drawing	Pins	Package Qty	Eco Plan (2)	Lead finish/ Ball material (6)	MSL Peak Temp (3)	Op Temp (°C)	Device Marking (4/5)	Samples
TPS92612QDBVRQ1	ACTIVE	SOT-23	DBV	5	3000	RoHS & Green	NIPDAU	Level-1-260C-UNLIM	-40 to 125	1J6F	Samples

(1) The marketing status values are defined as follows:

**ACTIVE:** Product device recommended for new designs.

**LIFEBUY:** TI has announced that the device will be discontinued, and a lifetime-buy period is in effect.

**NRND:** Not recommended for new designs. Device is in production to support existing customers, but TI does not recommend using this part in a new design.

**PREVIEW:** Device has been announced but is not in production. Samples may or may not be available.

**OBSOLETE:** TI has discontinued the production of the device.

(2) **RoHS:** TI defines "RoHS" to mean semiconductor products that are compliant with the current EU RoHS requirements for all 10 RoHS substances, including the requirement that RoHS substance do not exceed 0.1% by weight in homogeneous materials. Where designed to be soldered at high temperatures, "RoHS" products are suitable for use in specified lead-free processes. TI may reference these types of products as "Pb-Free".

**RoHS Exempt:** TI defines "RoHS Exempt" to mean products that contain lead but are compliant with EU RoHS pursuant to a specific EU RoHS exemption.

**Green:** TI defines "Green" to mean the content of Chlorine (Cl) and Bromine (Br) based flame retardants meet JS709B low halogen requirements of <=1000ppm threshold. Antimony trioxide based flame retardants must also meet the <=1000ppm threshold requirement.

(3) MSL, Peak Temp. - The Moisture Sensitivity Level rating according to the JEDEC industry standard classifications, and peak solder temperature.

(4) There may be additional marking, which relates to the logo, the lot trace code information, or the environmental category on the device.

(5) Multiple Device Markings will be inside parentheses. Only one Device Marking contained in parentheses and separated by a "-" will appear on a device. If a line is indented then it is a continuation of the previous line and the two combined represent the entire Device Marking for that device.

(6) Lead finish/Ball material - Orderable Devices may have multiple material finish options. Finish options are separated by a vertical ruled line. Lead finish/Ball material values may wrap to two lines if the finish value exceeds the maximum column width.

**Important Information and Disclaimer:**The information provided on this page represents TI's knowledge and belief as of the date that it is provided. TI bases its knowledge and belief on information provided by third parties, and makes no representation or warranty as to the accuracy of such information. Efforts are underway to better integrate information from third parties. TI has taken and continues to take reasonable steps to provide representative and accurate information but may not have conducted destructive testing or chemical analysis on incoming materials and chemicals. TI and TI suppliers consider certain information to be proprietary, and thus CAS numbers and other limited information may not be available for release.

In no event shall TI's liability arising out of such information exceed the total purchase price of the TI part(s) at issue in this document sold by TI to Customer on an annual basis.

**OTHER QUALIFIED VERSIONS OF TPS92612-Q1 :**

- Catalog : [TPS92612](#)

NOTE: Qualified Version Definitions:

- Catalog - TI's standard catalog product

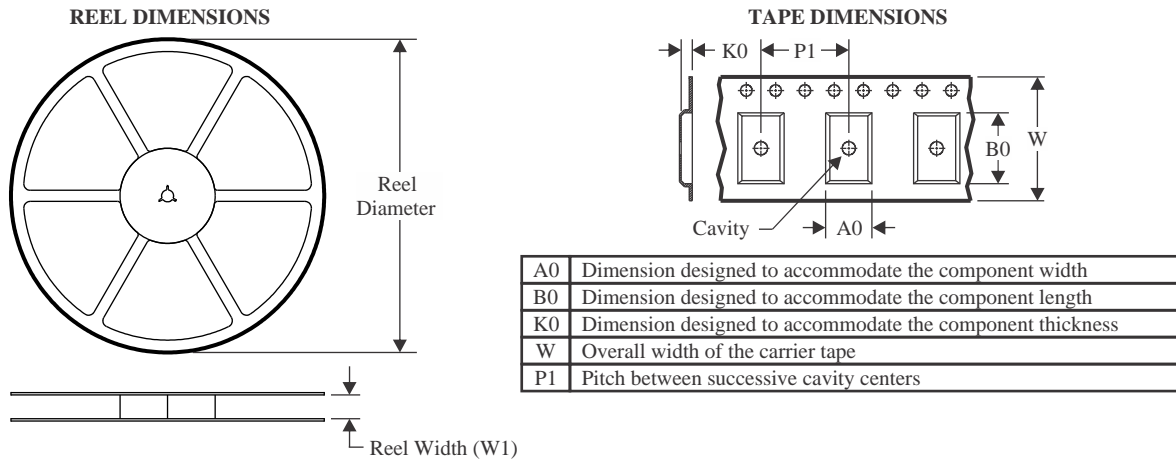
**TAPE AND REEL INFORMATION**

**QUADRANT ASSIGNMENTS FOR PIN 1 ORIENTATION IN TAPE**

\*All dimensions are nominal

Device	Package Type	Package Drawing	Pins	SPQ	Reel Diameter (mm)	Reel Width W1 (mm)	A0 (mm)	B0 (mm)	K0 (mm)	P1 (mm)	W (mm)	Pin1 Quadrant
TPS92612QDBVRQ1	SOT-23	DBV	5	3000	180.0	8.4	3.2	3.2	1.4	4.0	8.0	Q3

**TAPE AND REEL BOX DIMENSIONS**

\*All dimensions are nominal

Device	Package Type	Package Drawing	Pins	SPQ	Length (mm)	Width (mm)	Height (mm)
TPS92612QDBVRQ1	SOT-23	DBV	5	3000	210.0	185.0	35.0



# EXAMPLE BOARD LAYOUT

DBV0005A

SOT-23 - 1.45 mm max height

SMALL OUTLINE TRANSISTOR

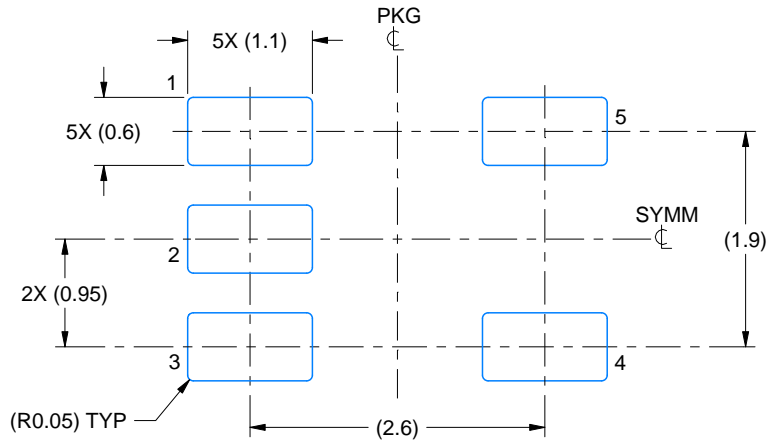

LAND PATTERN EXAMPLE  
EXPOSED METAL SHOWN  
SCALE:15X

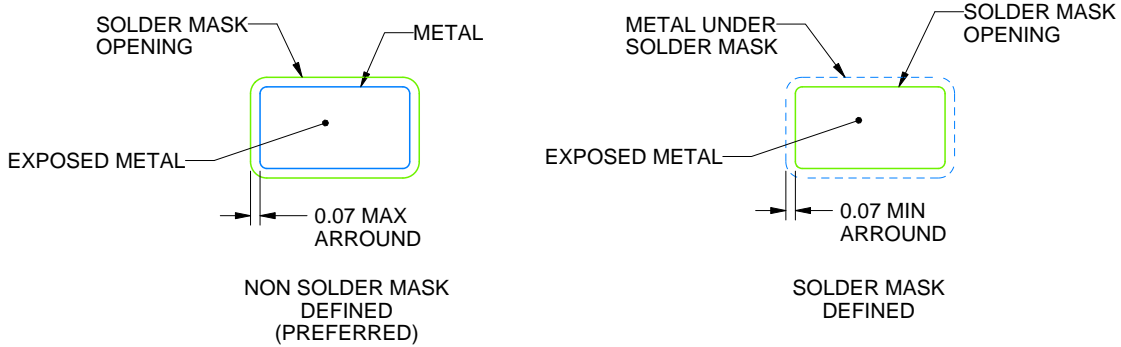

SOLDER MASK DETAILS

4214839/J 02/2024

NOTES: (continued)

- 6. Publication IPC-7351 may have alternate designs.
- 7. Solder mask tolerances between and around signal pads can vary based on board fabrication site.

# EXAMPLE STENCIL DESIGN

DBV0005A

SOT-23 - 1.45 mm max height

SMALL OUTLINE TRANSISTOR

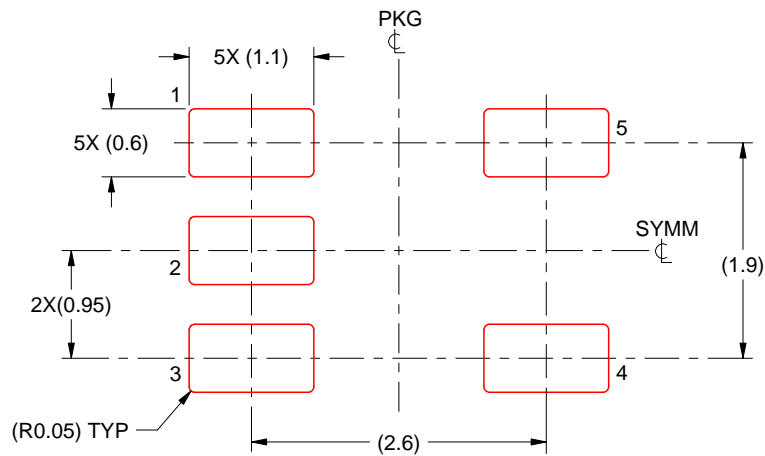

SOLDER PASTE EXAMPLE  
BASED ON 0.125 mm THICK STENCIL  
SCALE:15X

4214839/J 02/2024

NOTES: (continued)

8. Laser cutting apertures with trapezoidal walls and rounded corners may offer better paste release. IPC-7525 may have alternate design recommendations.
9. Board assembly site may have different recommendations for stencil design.

## IMPORTANT NOTICE AND DISCLAIMER

TI PROVIDES TECHNICAL AND RELIABILITY DATA (INCLUDING DATA SHEETS), DESIGN RESOURCES (INCLUDING REFERENCE DESIGNS), APPLICATION OR OTHER DESIGN ADVICE, WEB TOOLS, SAFETY INFORMATION, AND OTHER RESOURCES "AS IS" AND WITH ALL FAULTS, AND DISCLAIMS ALL WARRANTIES, EXPRESS AND IMPLIED, INCLUDING WITHOUT LIMITATION ANY IMPLIED WARRANTIES OF MERCHANTABILITY, FITNESS FOR A PARTICULAR PURPOSE OR NON-INFRINGEMENT OF THIRD PARTY INTELLECTUAL PROPERTY RIGHTS.

These resources are intended for skilled developers designing with TI products. You are solely responsible for (1) selecting the appropriate TI products for your application, (2) designing, validating and testing your application, and (3) ensuring your application meets applicable standards, and any other safety, security, regulatory or other requirements.

These resources are subject to change without notice. TI grants you permission to use these resources only for development of an application that uses the TI products described in the resource. Other reproduction and display of these resources is prohibited. No license is granted to any other TI intellectual property right or to any third party intellectual property right. TI disclaims responsibility for, and you will fully indemnify TI and its representatives against, any claims, damages, costs, losses, and liabilities arising out of your use of these resources.

TI's products are provided subject to [TI's Terms of Sale](#) or other applicable terms available either on [ti.com](https://www.ti.com) or provided in conjunction with such TI products. TI's provision of these resources does not expand or otherwise alter TI's applicable warranties or warranty disclaimers for TI products.

TI objects to and rejects any additional or different terms you may have proposed.

Mailing Address: Texas Instruments, Post Office Box 655303, Dallas, Texas 75265  
Copyright © 2024, Texas Instruments Incorporated

## Looking for pricing, stock, or lifecycle information?

Click below to explore more details on WIN SOURCE:

- [View DF11G-30DP-2V\(50\) on WIN SOURCE](#)
- [Hirose Electric Co Ltd Information](#)

## Optimize Your Supply Chain with WIN SOURCE Solutions

- ✓ Global Sourcing Solution
- ✓ Obsolete Management
- ✓ Cost Control Management
- ✓ Shortage Management
- ✓ Alternative Solution
- ✓ Excess Inventory Management