



**THE DATASHEET OF  
CS59201GDR8**



# CS59201

## Winchester Servo Preamp with Low Current Drain

The CS59201 is a low noise servo preamplifier for use with ferrite heads. It is a differential input, differential output design with fixed gain of approximately 100. Features include low noise, wide bandwidth and low current drain.

### Features

- 50 MHz Bandwidth
- Operates From Any of Three Standard Supply Voltages:
  - 8.3 V (IBM Compatible)
  - 10 V
  - 12 V
- Available in SO-8 Package

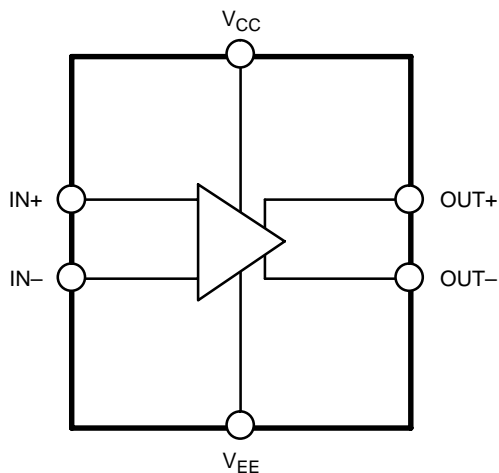

Figure 1. Block Diagram



ON Semiconductor™

<http://onsemi.com>



SO-8  
D SUFFIX  
CASE 751

### PIN CONNECTION AND MARKING DIAGRAM

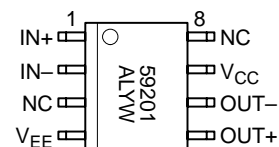

A = Assembly Location  
WL, L = Wafer Lot  
YY, Y = Year  
WW, W = Work Week

### ORDERING INFORMATION

Device	Package	Shipping
CS59201GD8	SO-8	95 Units/Rail
CS59201GDR8	SO-8	2500 Tape & Reel

# CS59201

## MAXIMUM RATINGS\*

Rating	Value	Unit
Power Supply Voltage ( $V_{CC} - V_{EE}$ )	14	V
Differential Input Voltage	5.0	V
Storage Temperature Range	-65 to +150	°C
Operating Temperature Range	0 to 70	°C
Thermal Resistance, Junction-to-Case, $R_{\theta JC}$	45	°C/W
Thermal Resistance, Junction-to-Ambient, $R_{\theta JA}$	165	°C/W
ESD Susceptibility (Human Body Model)	1.4	kV

\*The maximum package power dissipation must be observed.

## ELECTRICAL CHARACTERISTICS ( $T_A = 25^\circ\text{C}$ , ( $V_{CC} - V_{EE}$ ) = 7.0 V to 13.2 V; unless otherwise specified.)

Characteristic	Test Conditions	Min	Typ	Max	Unit
----------------	-----------------	-----	-----	-----	------

### General

Gain (Differential)	–	80	100	120	V/V
Bandwidth (3.0 dB)	$V_{IN} = 2.0 \text{ mV}$	30	50	–	MHz
Input Resistance	–	1040	1300	1560	$\Omega$
Input Capacitance	–	–	20	30	pF
Input Dynamic Range	–	3.0	–	–	mV
Power Supply Current	$(V_{CC} - V_{EE}) = 12 \text{ V}$	–	20	25	mA
Output Offset (Differential)	$R_S = 0, R_L = 130 \Omega$	–	–	200	mV
Equivalent Input Noise	$BW = 4.0 \text{ MHz}$ , Note 1.	–	0.7	1.0	nV/Hz
PSRR, Input Referred	$R_S = 0, f \leq 5.0 \text{ MHz}$ , Note 1.	55	60	–	dB
Gain Sensitivity (Supply)	$(V_{CC} - V_{EE}) = \pm 10\%$	–	–	$\pm 0.5$	%/V
Gain Sensitivity (Temp.)	$T_A = 25^\circ\text{C}$ to $70^\circ\text{C}$ , $R_L = 130 \Omega$	–	-0.1	–	%/°C
CMRR, Input Referred	$f \leq 5.0 \text{ MHz}$	60	70	–	dB

### Recommended

Supply Voltage ( $V_{CC} - V_{EE}$ )	–	7.45 9.0 10.8	8.3 10 12	9.15 11 13.2	V V V
Input Signal, $V_{IN}$	–	–	2.0	–	mV <sub>PP</sub>
Ambient Temperature, $T_A$	–	0	–	70	°C

1. 1.0 nV/root Hz and a bandwidth of 4.0 MHz equals 2.0  $\mu\text{VRMS}$ .

PACKAGE PIN DESCRIPTION

Pin Number	Pin Symbol	Function
SO-8		
1	IN+	Positive input to preamplifier.
2	IN-	Negative input to preamplifier.
3, 8	NC	No connection.
4	V <sub>EE</sub>	Negative supply voltage.
5	OUT+	One of the amplifier outputs.
6	OUT-	One of the amplifier outputs.
7	V <sub>CC</sub>	Positive supply voltage.

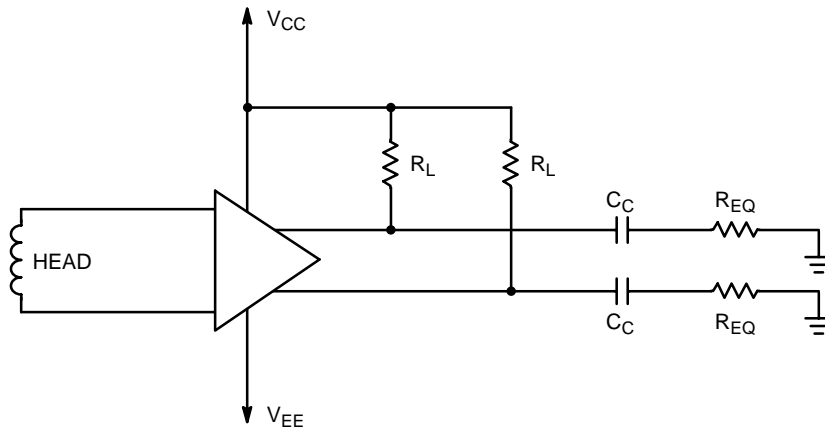

Figure 2. Applications Diagram

Recommended Load Conditions

1. Input must be AC coupled.
2. C<sub>C</sub>'s are AC coupling capacitors.
3. R<sub>L</sub>'s are DC bias and termination resistors, (recommended 130 Ω).
4. R<sub>EQ</sub> represents equivalent load resistance.
5. For gain calculations  $R_P = (R_L \times R_{EQ}) / (R_L + R_{EQ})$ .
6. Differential gain = 0.72 R<sub>P</sub> (±18%) (R<sub>P</sub> in Ω).
7. Ceramic capacitors (0.1 μF) are recommended for good power supply noise filtering.

# CS59201

## PACKAGE DIMENSIONS

SO-8  
D SUFFIX  
CASE 751-07  
ISSUE W

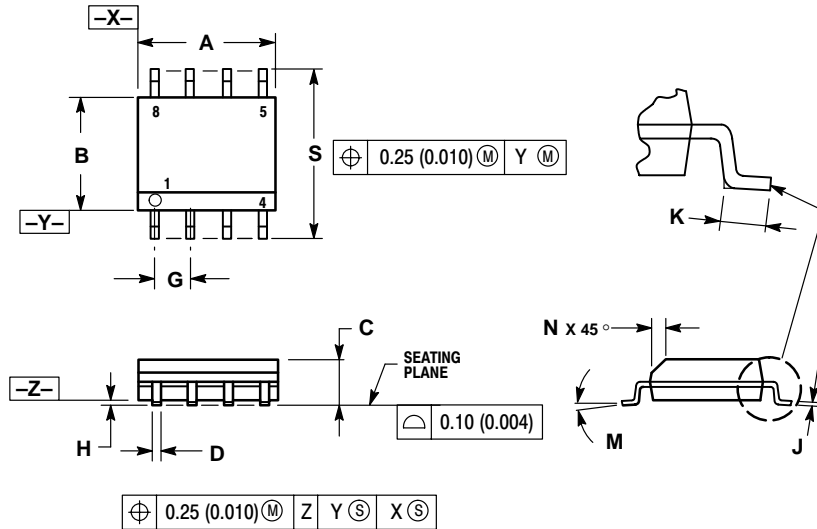

**NOTES:**

1. DIMENSIONING AND TOLERANCING PER ANSI Y14.5M, 1982.
2. CONTROLLING DIMENSION: MILLIMETER.
3. DIMENSION A AND B DO NOT INCLUDE MOLD PROTRUSION.
4. MAXIMUM MOLD PROTRUSION 0.15 (0.006) PER SIDE.
5. DIMENSION D DOES NOT INCLUDE DAMBAR PROTRUSION. ALLOWABLE DAMBAR PROTRUSION SHALL BE 0.127 (0.005) TOTAL IN EXCESS OF THE D DIMENSION AT MAXIMUM MATERIAL CONDITION.

DIM	MILLIMETERS		INCHES	
	MIN	MAX	MIN	MAX
A	4.80	5.00	0.189	0.197
B	3.80	4.00	0.150	0.157
C	1.35	1.75	0.053	0.069
D	0.33	0.51	0.013	0.020
G	1.27 BSC		0.050 BSC	
H	0.10	0.25	0.004	0.010
J	0.19	0.25	0.007	0.010
K	0.40	1.27	0.016	0.050
M	0°	8°	0°	8°
N	0.25	0.50	0.010	0.020
S	5.80	6.20	0.228	0.244

ON Semiconductor and  are trademarks of Semiconductor Components Industries, LLC (SCILLC). SCILLC reserves the right to make changes without further notice to any products herein. SCILLC makes no warranty, representation or guarantee regarding the suitability of its products for any particular purpose, nor does SCILLC assume any liability arising out of the application or use of any product or circuit, and specifically disclaims any and all liability, including without limitation special, consequential or incidental damages. "Typical" parameters which may be provided in SCILLC data sheets and/or specifications can and do vary in different applications and actual performance may vary over time. All operating parameters, including "Typicals" must be validated for each customer application by customer's technical experts. SCILLC does not convey any license under its patent rights nor the rights of others. SCILLC products are not designed, intended, or authorized for use as components in systems intended for surgical implant into the body, or other applications intended to support or sustain life, or for any other application in which the failure of the SCILLC product could create a situation where personal injury or death may occur. Should Buyer purchase or use SCILLC products for any such unintended or unauthorized application, Buyer shall indemnify and hold SCILLC and its officers, employees, subsidiaries, affiliates, and distributors harmless against all claims, costs, damages, and expenses, and reasonable attorney fees arising out of, directly or indirectly, any claim of personal injury or death associated with such unintended or unauthorized use, even if such claim alleges that SCILLC was negligent regarding the design or manufacture of the part. SCILLC is an Equal Opportunity/Affirmative Action Employer.

### PUBLICATION ORDERING INFORMATION

**Literature Fulfillment:**

Literature Distribution Center for ON Semiconductor  
P.O. Box 5163, Denver, Colorado 80217 USA  
Phone: 303-675-2175 or 800-344-3860 Toll Free USA/Canada  
Fax: 303-675-2176 or 800-344-3867 Toll Free USA/Canada  
Email: ONlit@hibbertco.com

**N. American Technical Support:** 800-282-9855 Toll Free USA/Canada

**JAPAN:** ON Semiconductor, Japan Customer Focus Center  
4-32-1 Nishi-Gotanda, Shinagawa-ku, Tokyo, Japan 141-0031  
Phone: 81-3-5740-2700  
Email: r14525@onsemi.com

**ON Semiconductor Website:** <http://onsemi.com>

For additional information, please contact your local Sales Representative.

## Looking for pricing, stock, or lifecycle information?

Click below to explore more details on WIN SOURCE:

 [View CS59201GDR8](#) on WIN SOURCE

 [ON Semiconductor](#) Information

## Optimize Your Supply Chain with WIN SOURCE Solutions

-  Global Sourcing Solution
-  Obsolete Management
-  Cost Control Management
-  Shortage Management
-  Alternative Solution
-  Excess Inventory Management