



**THE DATASHEET OF  
S71VS128RC0AHKCL0**





---

“Spansion, Inc.” and “Cypress Semiconductor Corp.” have merged together to deliver high-performance, high-quality solutions at the heart of today's most advanced embedded systems, from automotive, industrial and networking platforms to highly interactive consumer and mobile devices. The new company “Cypress Semiconductor Corp.” will continue to offer “Spansion, Inc.” products to new and existing customers.

### **CONTINUITY OF SPECIFICATIONS**

There is no change to this document as a result of offering the device as a Cypress product. Any changes that have been made are the result of normal document improvements and are noted in the document history page, where supported. Future revisions will occur when appropriate, and changes will be noted in a document history page.

### **CONTINUITY OF ORDERING PART NUMBERS**

Cypress continues to support existing part numbers. To order these products, please use only the Ordering Part Numbers listed in this document.

### **FOR MORE INFORMATION**

Please visit our website at [www.cypress.com](http://www.cypress.com) or contact your [local sales office](#) for additional information about Cypress products and services.

### **OUR CUSTOMERS**

Cypress is for true innovators – in companies both large and small.

Our customers are smart, aggressive, out-of-the-box thinkers who design and develop game-changing products that revolutionize their industries or create new industries with products and solutions that nobody ever thought of before.

### **ABOUT CYPRESS**

Founded in 1982, Cypress is the leader in advanced embedded system solutions for the world's most innovative automotive, industrial, home automation and appliances, consumer electronics and medical products. Cypress's programmable systems-on-chip, general-purpose microcontrollers, analog ICs, wireless and USB-based connectivity solutions and reliable, high-performance memories help engineers design differentiated products and get them to market first.

Cypress is committed to providing customers with the best support and engineering resources on the planet enabling innovators and out-of-the-box thinkers to disrupt markets and create new product categories in record time. To learn more, go to [www.cypress.com](http://www.cypress.com).



**S71VS/XS-R**

# MirrorBit® 1.8 V Simultaneous Read/Write Burst Mode Multiplexed Flash and Burst

## Features

- Power supply voltage of 1.7V to 1.95V
- Flash / pSRAM Burst Speed: 108 MHz, 104 MHz, 83 MHz
- MCP BGA Packages
  - 52 ball, 6.0 x 5.0 mm, 0.5 mm ball pitch
  - 56 ball, 7.7 x 6.2 mm, 0.5 mm ball pitch
  - 56 ball, 9.2 x 8.0 mm, 0.5 mm ball pitch
- Operating Temperature
  - Wireless, –25 °C to +85 °C
  - Industrial, –40 °C to +85 °C

## General Description

The S71VS-R Series is a product line of stacked Multi-Chip Package (MCP) memory solutions and consists of the following items:

- One or more S29VS-R Flash memory die
- One or more pSRAM

The products covered by this document are listed in the table below. For details about their specifications, please refer to their individual data sheet for further details.

Flash Density	pSRAM Density	Product
64 Mb	32 Mb	S71VS064RB0
128 Mb	32 Mb	S71VS128RB0
128 Mb	64 Mb	S71VS128RC0
256 Mb	64 Mb	S71VS256RC0
256 Mb	128 Mb	S71VS256RD0

For detailed specifications, please refer to the individual data sheets:

Document	Cypress Document Number
S29VS256R, S29VS128R datasheet	002-00833
S29VS064R datasheet	002-00949
32 Mb CellularRAM Address/Data multiplexed	SWM032D108M1R
32 Mb CellularRAM Address/Data multiplexed	SWM032D108M3R
64 Mb CellularRAM Address/Data multiplexed	SWM064D108M1R
128 Mb CellularRAM Address/Data multiplexed	SWM128D108M1R
128 Mb CellularRAM Address/Data multiplexed	SWM128D108M3R

# 1. Ordering Information

The order number is formed by a valid combinations of the following:

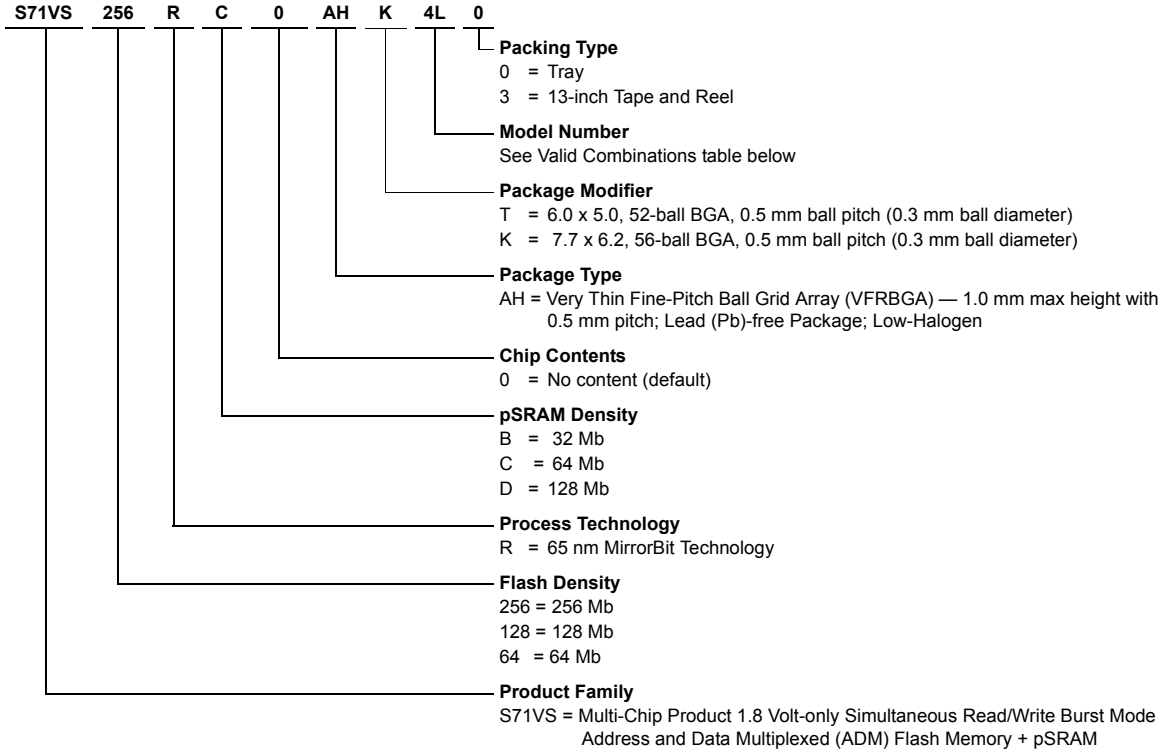

### 1.1 Valid Combinations

Valid Combinations list configurations planned to be supported in volume for this device. Consult your local sales office to confirm availability of specific valid combinations and to check on newly released combinations.

Base Ordering Part Number	Package	Model Number	Packing Type	pSRAM Type	Flash Boot	Temperature Range	Flash / pSRAM Speed	Pinout and Package Notes		
S71VS064RB0	AHT	3L	0, 3	SWM032D108M1R	Top	Wireless	108 MHz	Pinout: S71VS-R 52-ball Package: RLG052		
		BL			Bottom					
		4L			Top					
		CL			Bottom					
		0M		SWM032D108M3R	Top	Industrial		Pinout: S71VS-R 52-ball Package: RSE052		
		8M			Bottom					
		3M			Top					
		BM			Bottom					
S71VS128RB0	AHK	3L		SWM032D108M1R	Top	Wireless	108 MHz	Pinout: S71VS-R 56-ball Package: RLA056		
		BL			Bottom					
		4L			Top					
		CL			Bottom			Pinout: S71VS-R 56-ball Package: RSD056		
S71VS128RC0	AHK	4L			SWM064D108M1R		Top		108 MHz	Pinout: S71VS-R 56-ball Package: RSD056
		CL					Bottom			
S71VS256RC0	AHK	4L			SWM064D108M1R		Top	Wireless	108 MHz	Pinout: S71VS-R 56-ball Package: RLA056
		CL					Bottom			
S71VS256RD0	AHK	3L	SWM128D108M1R	Top	Wireless	108 MHz	Pinout: S71VS-R 56-ball Package: RSD056			
		BL		Bottom						
		4L		Top						
		CL		Bottom						
		3C		Top		83 MHz				
		BC		Bottom						
		3M	SWM128D108M3R	Top	Industrial	108 MHz				

**Note:**  
If a choice exists, Spansion recommends Top Boot.

## 2. Input/Output Descriptions

Table 2.1 identifies the input and output package connections provided on the device.

**Table 2.1** Input/Output Descriptions (Sheet 1 of 2)

Symbol	Description	Flash	RAM
AMAX–A16	Address inputs.	X	X
A/DQ15–A/DQ0	Multiplexed Address/Data.	X	X
AVD#	Address Valid input. Indicates to device that the valid address is present on the address inputs. Low = for asynchronous mode, indicates valid address; for burst mode, causes starting address to be latched. High = device ignores address inputs	X	X
CLK	Clock input. In burst mode, after the initial word is output, subsequent active edges of CLK increment the internal address counter. Should be at $V_{IL}$ or $V_{IH}$ while in asynchronous mode.	X	X
DNU	Do Not Use. A device internal signal may be connected to the package connector. The connection may be used by Spansion for test or other purposes and is not intended for connection to any host system signal. Any DNU signal related function will be inactive when the signal is at $V_{IL}$ . The signal has an internal pull-down resistor and may be left unconnected in the host system or may be tied to $V_{SS}$ . Do not use these connections for PCB signal routing channels. Do not connect any host system signal to these connections.		
OE#	Output Enable input. Asynchronous relative to CLK for the Burst mode.	X	X
F-CE#	Chip-enable input for Flash. Asynchronous relative to CLK for Burst Mode.	X	
F-RDY/R-WAIT	Ready output; indicates the status of the Burst read. Flash Memory RDY (using default “Active HIGH” configuration) $V_{OL}$ = data invalid $V_{OH}$ = data valid Note: The default polarity for the pSRAM WAIT signal is opposite the default polarity of the Flash RDY signal. pSRAM WAIT (using default “Active HIGH” configuration) $V_{OL}$ = data valid $V_{OH}$ = data invalid To match polarities, change bit 10 of the pSRAM Bus Configuration Register to 0 (Active LOW WAIT). Alternately, change bit 10 of the Flash Configuration Register to 0 (Active LOW RDY).	X	X
F-RST#	Hardware reset input. Low = device resets and returns to reading array data	X	
F- $V_{PP}$	Accelerated input. At $V_{HH}$ , accelerates programming; automatically places device in unlock bypass mode. At $V_{IL}$ , disables all program and erase functions. Should be at $V_{IH}$ for all other conditions.	X	
NC	Not Connected. No device internal signal is connected to the package connector nor is there any future plan to use the connector for a signal. The connection may safely be used for routing space for a signal on a Printed Circuit Board (PCB).		
R-CE#	Chip-enable input for pSRAM.		X
R-CRE	Control Register Enable (pSRAM).		X
R-LB#	Lower Byte Control (pSRAM).		X
R-UB#	Upper Byte Control (pSRAM).		X

Table 2.1 Input/Output Descriptions (Sheet 2 of 2)

Symbol	Description	Flash	RAM
RFU	Reserved For Future Use. No device internal signal is currently connected to the package connector but there is potential future use for the connector for a signal. It is recommended to not use RFU connectors for PCB routing channels so that the PCB may take advantage of future enhanced features in compatible footprint devices.		
V <sub>CC</sub>	Flash and pSRAM 1.8 Volt-only single power supply.	X	X
V <sub>CCQ</sub>	Flash and pSRAM Input/Output Power Supply.	X	X
V <sub>SS</sub>	Ground.	X	X
V <sub>SSQ</sub>	Input/Output Ground.	X	X
WE#	Write Enable input.	X	X

### 3. MCP Block Diagram

Figure 3.1 S71VS-R MCP Block Diagram

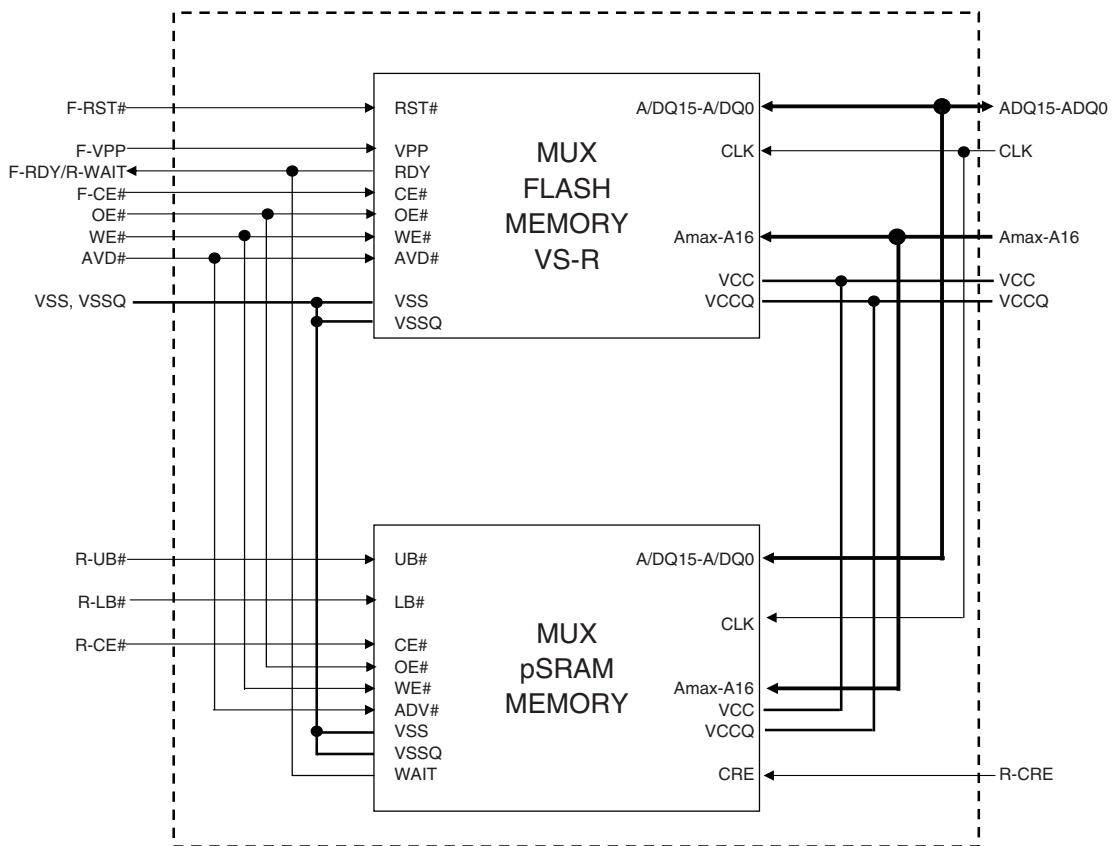

## 4. Connection Diagrams/Physical Dimensions

This section contains the I/O designations and package specifications for the S71VS-R.

### 4.1 Special Handling Instructions for FBGA Packages

Special handling is required for Flash Memory products in FBGA packages.

Flash memory devices in FBGA packages may be damaged if exposed to ultrasonic cleaning methods. The package and/or data integrity may be compromised if the package body is exposed to temperatures above 150 °C for prolonged periods of time.

### 4.2 Connection Diagrams

**Figure 4.1** S71VS-R 56-ball Fine-Pitch Ball Grid Array

(Top View, Balls Facing Down)

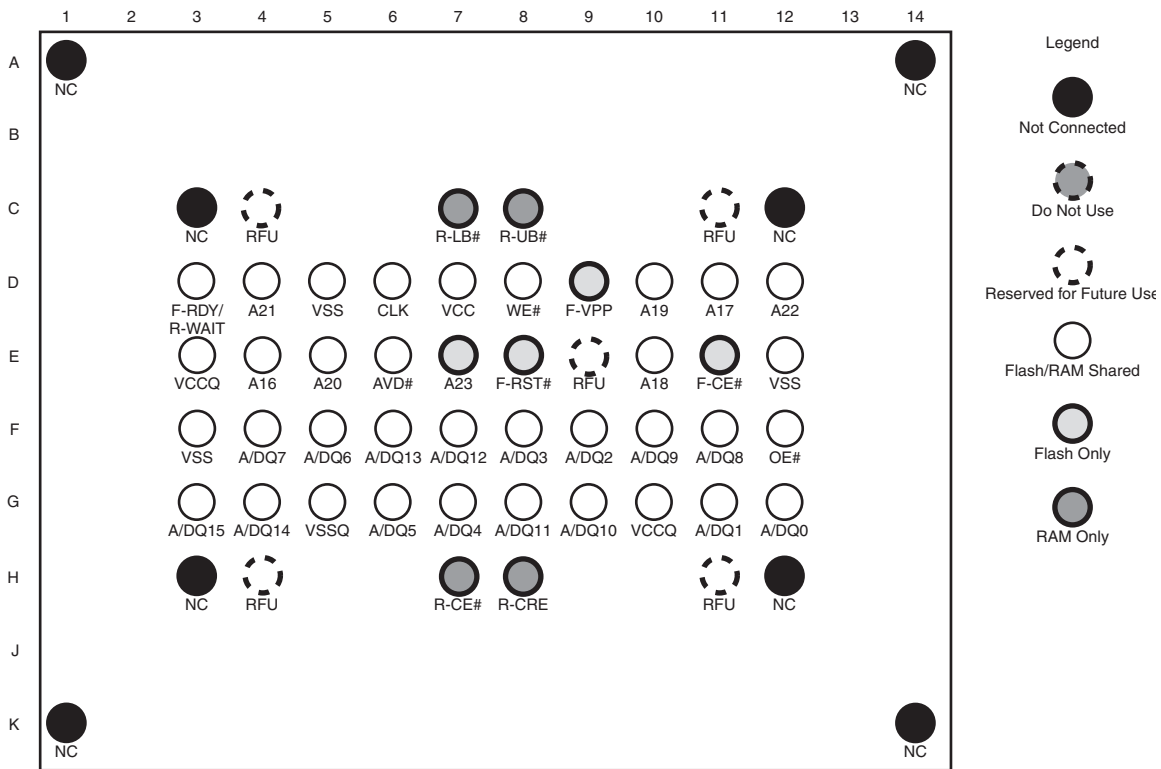

**Figure 4.2** S71VS-R 52-ball Fine-Pitch Ball Grid Array

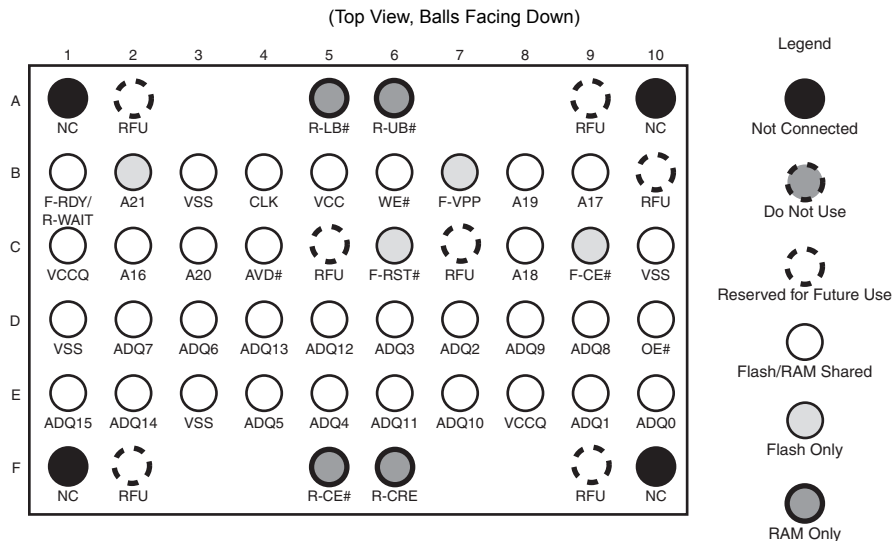

**Notes:**

- Addresses are shared between Flash and RAM depending on the density of the pSRAM.
- V<sub>SS</sub> and V<sub>SSQ</sub> must be connected together.

MCP	Flash-Only Addresses	Shared Addresses	Shared ADQ Pins
S71VS064RB0	A21	A20–A16	A/DQ15-A/DQ0
S71VS128RB0	A22–A21	A20–A16	
S71VS128RC0	A22	A21–A16	
S71VS256RC0	A23–A22	A21–A16	
S71VS256RD0	A23	A22–A16	

### 4.3 Physical Dimensions

Figure 4.3 RLG052 - 52-ball VFRBGA 6.0 x 5.0 mm

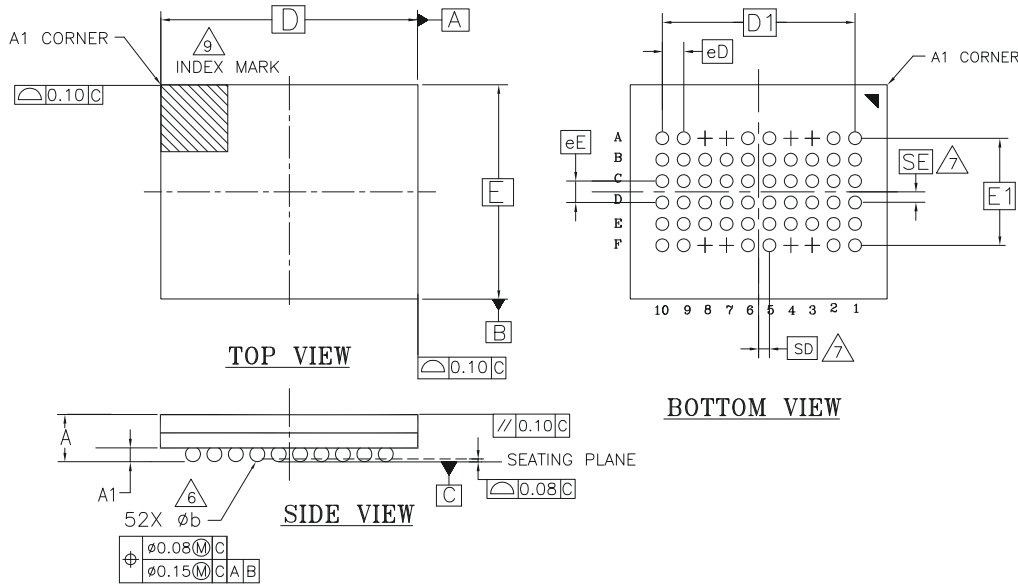

PACKAGE	RLG 052			
JEDEC	N/A			
	6.00 mm x 5.00 mm PACKAGE			
SYMBOL	MIN	NOM	MAX	NOTE
A	---	---	1.00	PROFILE
A1	0.18	---	---	BALL HEIGHT
D	6.00 BSC.			BODY SIZE
E	5.00 BSC.			BODY SIZE
D1	4.50 BSC.			MATRIX FOOTPRINT
E1	2.50 BSC.			MATRIX FOOTPRINT
MD	10			MATRIX SIZE D DIRECTION
ME	6			MATRIX SIZE E DIRECTION
n	52			BALL COUNT
phi_b	0.25	0.30	0.35	BALL DIAMETER
e	0.50 BSC.			BALL PITCH
SE/SD	0.25 BSC.			SOLDER BALL PLACEMENT
	3A,3F,4A,4F,7A,7F,8A,8F			DEPOPULATED SOLDER BALLS

NOTES:

- DIMENSIONING AND TOLERANCING PER ASME Y14.5M-1994.
- ALL DIMENSIONS ARE IN MILLIMETERS.
- BALL POSITION DESIGNATION PER JEP 95, SECTION 4.3, SPP-010.
- [e] REPRESENTS THE SOLDER BALL GRID PITCH.
- SYMBOL "MD" IS THE BALL MATRIX SIZE IN THE "D" DIRECTION.  
SYMBOL "ME" IS THE BALL MATRIX SIZE IN THE "E" DIRECTION.  
n IS THE NUMBER OF POPULATED SOLDER BALL POSITIONS FOR MATRIX SIZE MD X ME
- DIMENSION "b" IS MEASURED AT THE MAXIMUM BALL DIAMETER IN A PLANE PARALLEL TO DATUM C.
- SD AND SE ARE MEASURED WITH RESPECT TO DATUMS A AND B AND DEFINE THE POSITION OF THE CENTER SOLDER BALL IN THE OUTER ROW.  
WHEN THERE IS AN ODD NUMBER OF SOLDER BALLS IN THE OUTER ROW SD OR SE = 0.00.  
WHEN THERE IS AN EVEN NUMBER OF SOLDER BALLS IN THE OUTER ROW, SD OR SE = [e/2]
- "+" INDICATES THE THEORETICAL CENTER OF DEPOPULATED BALLS.
- A1 CORNER TO BE IDENTIFIED BY CHAMFER, LASER OR INK MARK, METALLIZED MARK INDENTATION OR OTHER MEANS.

g1002-1 \ 116-038.63 \ 08.25.10

Figure 4.4 RLA056 - 56-ball VFRBGA 7.7 x 6.2 mm

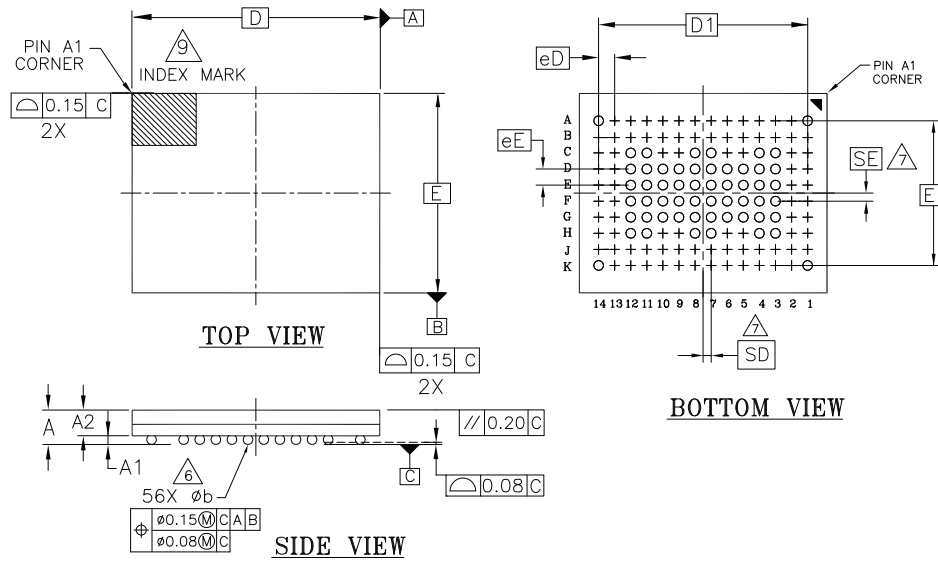

PACKAGE	RLA 056			
JEDEC	N/A			
D X E	7.70 mm x 6.20 mm PACKAGE			
SYMBOL	MIN	NOM	MAX	NOTE
A	---	---	1.00	PROFILE
A1	0.18	---	---	BALL HEIGHT
A2	0.62	---	0.74	BODY THICKNESS
D	7.70 BSC.			BODY SIZE
E	6.20 BSC.			BODY SIZE
D1	6.50 BSC.			MATRIX FOOTPRINT
E1	4.50 BSC.			MATRIX FOOTPRINT
MD	14			MATRIX SIZE D DIRECTION
ME	10			MATRIX SIZE E DIRECTION
n	56			BALL COUNT
$\phi b$	0.25	0.30	0.35	BALL DIAMETER
eE	0.50 BSC.			BALL PITCH
eD	0.50 BSC.			BALL PITCH
SE SD	0.25 BSC.			SOLDER BALL PLACEMENT
	A2~A9, B1~B10, C1 C2, C9,C10,D1,D2,D9,D10, E1,E2,E3,E8,E9,E10,F1,F2, F3,F8,F9,F10,G1,G2,G9,G10, H1,H2,H9,H10,J1,J2,J3,J8,J9, J10,K1,K2,K3,K8,K9,K10, L1,L2,L9,L10,M1,M2,M9,M10, N1~N10, P2~P9			DEPOPULATED SOLDER BALLS

NOTES:

- DIMENSIONING AND TOLERANCING PER ASME Y14.5M-1994.
- ALL DIMENSIONS ARE IN MILLIMETERS.
- BALL POSITION DESIGNATION PER JEP 95, SECTION 4.3, SPP-010.
- [e] REPRESENTS THE SOLDER BALL GRID PITCH.
- SYMBOL "MD" IS THE BALL MATRIX SIZE IN THE "D" DIRECTION.  
SYMBOL "ME" IS THE BALL MATRIX SIZE IN THE "E" DIRECTION.  
n IS THE NUMBER OF POPULATED SOLDER BALL POSITIONS FOR MATRIX SIZE MD X E
- $\Delta$  DIMENSION "b" IS MEASURED AT THE MAXIMUM BALL DIAMETER IN A PLANE PARALLEL TO DATUM C.
- $\Delta$  SD AND SE ARE MEASURED WITH RESPECT TO DATUMS A AND B AND DEFINE THE POSITION OF THE CENTER SOLDER BALL IN THE OUTER ROW.  
WHEN THERE IS AN ODD NUMBER OF SOLDER BALLS IN THE OUTER ROW SD OR SE = 0.000.  
WHEN THERE IS AN EVEN NUMBER OF SOLDER BALLS IN THE OUTER ROW, SD OR SE = [e/2]
- \*+ INDICATES THE THEORETICAL CENTER OF DEPOPULATED BALLS.
- $\Delta$  A1 CORNER TO BE IDENTIFIED BY CHAMFER, LASER OR INK MARK, METALLIZED MARK INDENTATION OR OTHER MEANS.
- OUTLINE AND DIMENSIONS PER CUSTOMER REQUIREMENT.

g1007 \ F16-038.63 \ 08.18.10

**Figure 4.5 RSD056—56-ball VFRBGA 7.7 x 6.2 mm**

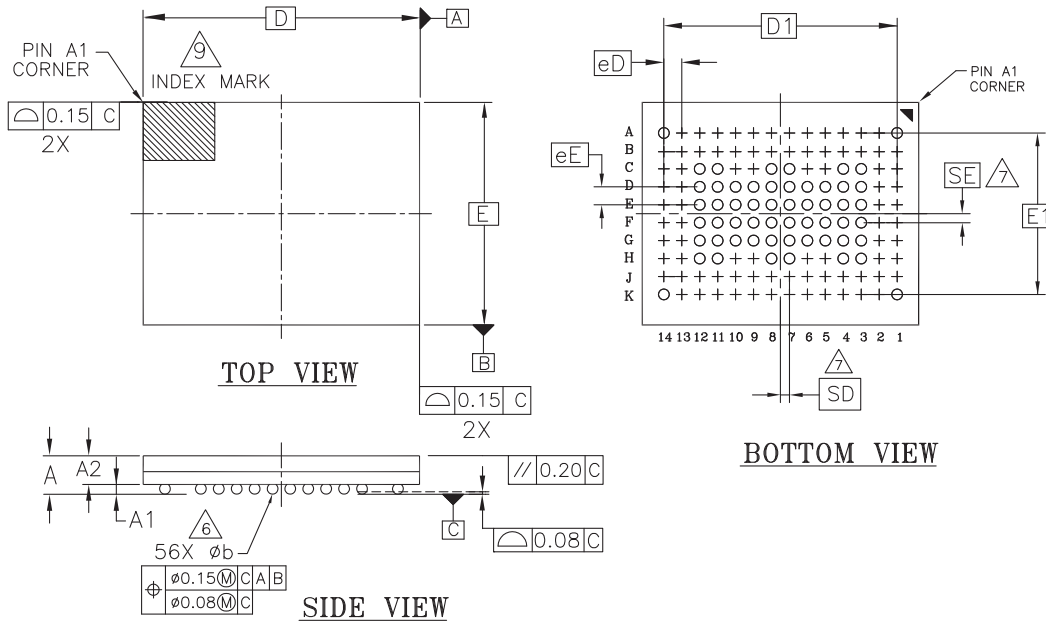

PACKAGE	RSD 056			NOTE
JEDEC	N/A			
D x E	7.70 mm x 6.20 mm PACKAGE			
SYMBOL	MIN	NOM	MAX	
A	0.80	0.90	1.00	PROFILE
A1	0.18	---	---	BALL HEIGHT
A2	0.62	---	0.74	BODY THICKNESS
D	7.70 BSC			BODY SIZE
E	6.20 BSC			BODY SIZE
D1	6.50 BSC			MATRIX FOOTPRINT
E1	4.50 BSC			MATRIX FOOTPRINT
MD	14			MATRIX SIZE D DIRECTION
ME	10			MATRIX SIZE E DIRECTION
n	56			BALL COUNT
Øb	0.25	0.30	0.35	BALL DIAMETER
eE	0.50 BSC			BALL PITCH
eD	0.50 BSC			BALL PITCH
SE   SD	0.25 BSC			SOLDER BALL PLACEMENT
	<small>A2=A9, B1=B10, C1,C2,C9,10,D1,D2,D9,D10                      E1,E2,E3,E8,E9,E10,F1,F2,F3,F8,F9,F10,G1,G2,G9,G10                      H1,H2,H9,H10,I1,I2,I3,I8,I9,I10,K1,K2,K3,K8,K9,K10                      L1,L2,L9,L10,M1,M2,M9,M10, N1-N10, P2-P9</small>			DEPOPULATED SOLDER BALLS

**NOTES:**

- DIMENSIONING AND TOLERANCING METHODS PER ASME Y14.5M-1994.
- ALL DIMENSIONS ARE IN MILLIMETERS.
- BALL POSITION DESIGNATION PER JEP95, SECTION 4.3, SPP-010.
- [e] REPRESENTS THE SOLDER BALL GRID PITCH.
- SYMBOL "MD" IS THE BALL MATRIX SIZE IN THE "D" DIRECTION.  
 SYMBOL "ME" IS THE BALL MATRIX SIZE IN THE "E" DIRECTION.  
 n IS THE NUMBER OF POPULATED SOLDER BALL POSITIONS FOR MATRIX SIZE MD X ME.
- DIMENSION "b" IS MEASURED AT THE MAXIMUM BALL DIAMETER IN A PLANE PARALLEL TO DATUM C.
- SD AND SE ARE MEASURED WITH RESPECT TO DATUMS A AND B AND DEFINE THE POSITION OF THE CENTER SOLDER BALL IN THE OUTER ROW.  
 WHEN THERE IS AN ODD NUMBER OF SOLDER BALLS IN THE OUTER ROW SD OR SE = 0.000.  
 WHEN THERE IS AN EVEN NUMBER OF SOLDER BALLS IN THE OUTER ROW, SD OR SE = [e/2]
- "+" INDICATES THE THEORETICAL CENTER OF DEPOPULATED BALLS.
- A1 CORNER TO BE IDENTIFIED BY CHAMFER, LASER OR INK MARK, METALLIZED MARK INDENTATION OR OTHER MEANS.
- OUTLINE AND DIMENSIONS PER CUSTOMER REQUIREMENT.

3719 \ 116-038.B3 \ 1.26.9

Figure 4.6 RSE052—52-ball VFRBGA 6.0 x 5.0 mm

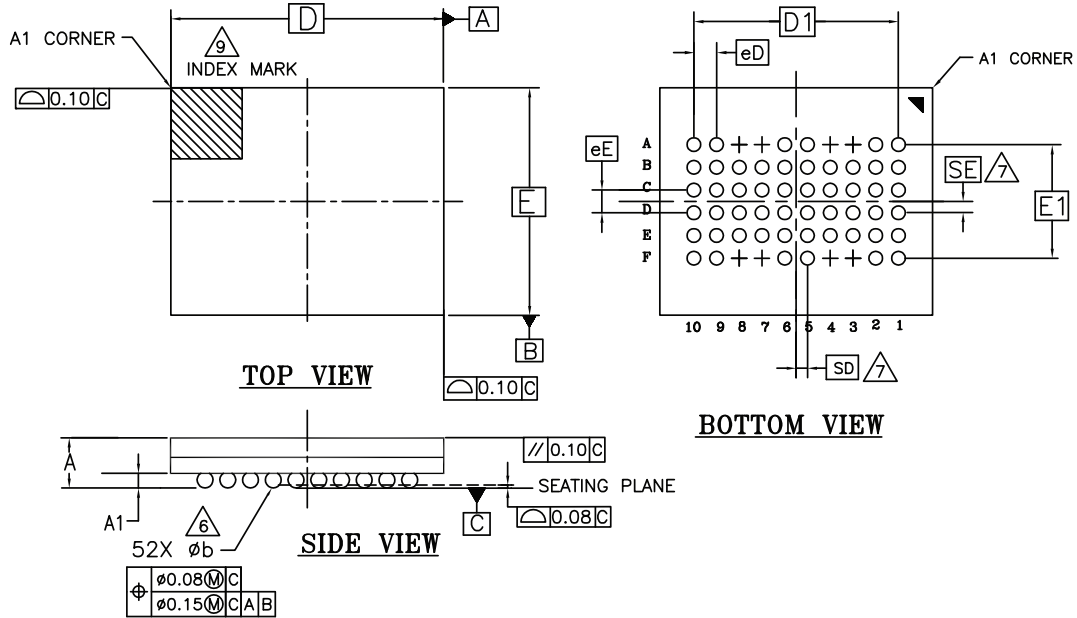

PACKAGE	RSE 052			
JEDEC	N/A			
D X E	6.00 mm x 5.00 mm PACKAGE			
SYMBOL	MIN	NOM	MAX	NOTE
A	---	---	1.00	PROFILE
A1	0.18	---	---	BALL HEIGHT
D	6.00 BSC.			BODY SIZE
E	5.00 BSC.			BODY SIZE
D1	4.50 BSC.			MATRIX FOOTPRINT
E1	2.50 BSC.			MATRIX FOOTPRINT
MD	10			MATRIX SIZE D DIRECTION
ME	6			MATRIX SIZE E DIRECTION
n	52			BALL COUNT
phi b	0.25	0.30	0.35	BALL DIAMETER
e	0.50 BSC.			BALL PITCH
SE/SD	0.25 BSC.			SOLDER BALL PLACEMENT
	3A,3F,4A,4F,7A,7F,8A,8F			DEPOPULATED SOLDER BALLS

NOTES:

- DIMENSIONING AND TOLERANCING PER ASME Y14.5M-1994.
- ALL DIMENSIONS ARE IN MILLIMETERS.
- BALL POSITION DESIGNATION PER JEP 95, SECTION 4.3, SPP-010.
- [e] REPRESENTS THE SOLDER BALL GRID PITCH.
- SYMBOL "MD" IS THE BALL MATRIX SIZE IN THE "D" DIRECTION.  
SYMBOL "ME" IS THE BALL MATRIX SIZE IN THE "E" DIRECTION.  
n IS THE NUMBER OF POPULATED SOLDER BALL POSITIONS FOR MATRIX SIZE MD X ME
- DIMENSION "b" IS MEASURED AT THE MAXIMUM BALL DIAMETER IN A PLANE PARALLEL TO DATUM C.
- SD AND SE ARE MEASURED WITH RESPECT TO DATUMS A AND B AND DEFINE THE POSITION OF THE CENTER SOLDER BALL IN THE OUTER ROW.  
WHEN THERE IS AN ODD NUMBER OF SOLDER BALLS IN THE OUTER ROW SD OR SE = 0.000.  
WHEN THERE IS AN EVEN NUMBER OF SOLDER BALLS IN THE OUTER ROW, SD OR SE = [e/2]
- "+" INDICATES THE THEORETICAL CENTER OF DEPOPULATED BALLS.
- A1 CORNER TO BE IDENTIFIED BY CHAMFER, LASER OR INK MARK, METALLIZED MARK INDENTATION OR OTHER MEANS.

g1004-1 | f16-038.63 | 08.25.10

## 5. Revision History

Section	Description
<b>Revision 01 (August 25, 2008)</b>	
	Initial release
<b>Revision 02 (November 4, 2008)</b>	
Global	Added OPNs S71VS064RB0AHT00/04/80/84
Connection Diagrams	Added S71VS-R 52-ball connection diagram
Physical Dimensions	Added RSB052
General Description	Changed 128 Mb Mux pSRAM PID from TBD to pSRAM_39
<b>Revision 03 (November 10, 2008)</b>	
General Description	Changed 64 Mb MUX pSRAM Type 3 PID from muxpsram_14 to muxpsram_15
<b>Revision 04 (January 13, 2009)</b>	
Physical Dimensions	Replaced NLD056 with NSD056
<b>Revision 05 (January 23, 2009)</b>	
Valid Combinations	Added OPN S71VS128RC0AHK20
Physical Dimensions	Added RSD056
<b>Revision 06 (March 11, 2009)</b>	
Valid Combinations	Added 108 MHz speed grade to S71VS128RC0 and S71VS256RC0
<b>Revision 07 (September 29, 2009)</b>	
General Description	Added S71VS128RB0; added muxpsram_10
Valid Combinations	Added OPN S71VS128RB0
<b>Revision 08 (April 9, 2010)</b>	
General Description	Added SWM064D108M1R Updated pSRAM documentation names
Valid Combinations	Added OPNs: S71VS128RC0AHK4L, S71VS256RC0AHK4L Removed Bottom Boot options
Connection Diagrams	Updated V <sub>SSQ</sub> ball to V <sub>SS</sub>
<b>Revision 09 (May 4, 2010)</b>	
General Description	Added reference to S29VS064R data sheet Removed CustComspec_01 for 32 Mb MUX pSRAM
Valid Combinations	Corrected pSRAM type for S71VS064RB0 from CustComspec_01 to SWM032D108M1R Added OPNs: S71VS064RB0AHT0L, S71VS256RD0AHK40
<b>Revision 10 (June 14, 2010)</b>	
General Description	Removed S71XS256RD0 from table Unified data sheet reference for S29VS/XS-R Removed MUX pSRAM Type 3 Added SWM128D108M1R
Valid Combinations	Restored necessary bottom boot options. Added OPNs: S71VS256RD0AHK3L/BL/3C/BC Removed OPNs: S71VS064RB0AHT00/04 Updated MUX pSRAM Type 3 entries to the Common RAM type specifications Removed table after Figure 4.3 S71XS-R 56-ball Fine-Pitch Ball Grid Array

Section	Description
<b>Revision 11 (July 28, 2010)</b>	
Features	Corrected MCP BGA Packages information
Ordering Information	Corrected Package Modifier information Removed 7 inch Tape and Reel option
Valid Combinations	Corrected package information for S71VS064RB0AHT0L Added OPN S71VS064RB0AHT8L, S71VS128RC0AHKCL, S71VS256RC0AHKCL Removed OPN S71VS256RD0AHK40
MCP Block Diagram	Removed figure S71XS-R MCP Block Diagram
Connection Diagrams/ Physical Dimensions	Corrected figure S71VS-R 52-ball Fine-Pitch Ball Grid Array Removed figure S71XS-R 56-ball Fine-Pitch Ball Grid Array Replaced figure RSB052—52-ball VFBGA 5.0 x 7.5 mm with RSE052—52-ball VFRBGA 6.0 x 5.0 mm Refreshed DNU/RFU/NC definitions
<b>Revision 12 (August 27, 2010)</b>	
Valid Combinations	Corrected package information for S71VS128RB0AHK0L/8L (RLA056) Corrected speed for OPNs S71VS256RD0AHK3L/BL to 108 MHz
Connection Diagrams	Reverted DNU balls to RFU
Physical Dimensions	Added diagram for RLA056
<b>Revision 13 (December 9, 2010)</b>	
Features	Added Industrial temperature
General Description	Added references to S29VS_XS-R_SP, S29VS064R_XS064R_SP, SWM032D108M3R, SWM128D108M3R
Valid Combinations	Added OPNs S71VS064RB0AHT3L/BL/0M/8M, S71VS128RB0AHK3L/BL, S71VS256RD0AHK3M, S71VS256RD0AHK40/C0 Added Temperature Range Column
<b>Revision 14 (April 13, 2011)</b>	
General Description	Removed SWM032D108M1N and SWM064D108M1N references
Valid Combinations	Removed OPNs S71VS064RB0AHT3M/BM, S71VS128RB0AHK2L/AL, S71VS128RC0AHK20, S71VS128RC0ZHKxx, S71VS256RC0ZHKxx, S71VS256RD0ZHExx Physical Dimensions: Removed NLB056 and NSD056 diagrams. Added diagram for RLG052
<b>Revision 15 (June 20, 2011)</b>	
Valid Combinations	Added OPNs S71VS128RB0AHK4L/CL, , S71VS064RB0AHT4L/CL
<b>Revision 16 (June 29, 2012)</b>	
Valid Combinations	Added OPNs S71VS064RB0AHT3M/BM
<b>Revision 17 (October 2, 2012)</b>	
Valid Combinations	Updated the S71VS256RC0AHK4L/CL package from RSD056 to RLA056
<b>Revision 18 (January 31, 2014)</b>	
General Description	Removed 128 Mb MUX pSRAM Type 5
Valid Combinations	Removed OPNs S71VS064RB0AHT0L/BL, S71VS256RD0AHK40/C0 Added OPN S71VS256RD0AHK4L/CL

**Document History Page**

Document Title: S71VS/XS-R, MirrorBit® 1.8 V Simultaneous Read/Write Burst Mode Multiplexed Flash and Burst Mode pSRAM				
Document Number: 002-00377				
Rev.	ECN No.	Orig. of Change	Submission Date	Description of Change
**	—	RYSU	08/25/2008	Initial release
*A	—	RYSU	11/04/2008	Global: Added OPNs S71VS064RB0AHT00/04/80/84 Connection Diagrams: Added S71VS-R 52-ball connection diagram Physical Dimensions: Added RSB052 General Description: Changed 128 Mb Mux pSRAM PID from TBD to pSRAM_39
*B	—	RYSU	11/10/2008	General Description: Changed 64 Mb MUX pSRAM Type 3 PID from muxpsram_14 to muxpsram_15
*C	—	RYSU	01/13/2009	Physical Dimensions: Replaced NLD056 with NSD056
*D	—	RYSU	01/23/2009	Valid Combinations: Added OPN S71VS128RC0AHK20 Physical Dimensions: Added RSD056
*E	—	RYSU	03/11/2009	Valid Combinations: Added 108 MHz speed grade to S71VS128RC0 and S71VS256RC0
*F	—	RYSU	09/29/2009	General Description: Added S71VS128RB0; added muxpsram_10 Valid Combinations: Added OPN S71VS128RB0
*G	—	RYSU	04/09/2010	General Description: Added SWM064D108M1R Updated pSRAM documentation names Valid Combinations: Added OPNs: S71VS128RC0AHK4L, S71VS256RC0AHK4L Removed Bottom Boot options Connection Diagrams: Updated VSSQ ball to VSS
*H	—	RYSU	05/04/2010	General Description: Added reference to S29VS064R data sheet Removed CustComspec_01 for 32 Mb MUX pSRAM Valid Combinations: Corrected pSRAM type for S71VS064RB0 from CustComspec_01 to SWM032D108M1R Added OPNs: S71VS064RB0AHT0L, S71VS256RD0AHK40

Document History Page (Continued)

Document Title: S71VS/XS-R, MirrorBit® 1.8 V Simultaneous Read/Write Burst Mode Multiplexed Flash and Burst Mode pSRAM				
Document Number: 002-00377				
Rev.	ECN No.	Orig. of Change	Submission Date	Description of Change
*I	—	RYSU	06/14/2010	<p>General Description:            Removed S71XS256RD0 from table            Unified data sheet reference for S29VS/XS-R            Removed MUX pSRAM Type 3            Added SWM128D108M1R</p> <p>Valid Combinations:            Restored necessary bottom boot options.            Added OPNs: S71VS256RD0AHK3L/BL/3C/BC            Removed OPNs: S71VS064RB0AHT00/04            Updated MUX pSRAM Type 3 entries to the Common RAM type specifications            Removed table after Figure 4.3 S71XS-R 56-ball Fine-Pitch Ball Grid Array</p>
*J	—	RYSU	07/28/2010	<p>Features:            Corrected MCP BGA Packages information</p> <p>Ordering Information:            Corrected Package Modifier information            Removed 7 inch Tape and Reel option</p> <p>Valid Combinations:            Corrected package information for S71VS064RB0AHT0L            Added OPN S71VS064RB0AHT8L, S71VS128RC0AHKCL,            S71VS256RC0AHKCL            Removed OPN S71VS256RD0AHK40</p> <p>MCP Block Diagram:            Removed figure S71XS-R MCP Block Diagram</p> <p>Connection Diagrams/Physical Dimensions:            Corrected figure S71VS-R 52-ball Fine-Pitch Ball Grid Array            Removed figure S71XS-R 56-ball Fine-Pitch Ball Grid Array            Replaced figure RSB052—52-ball VFBGA 5.0 x 7.5 mm            with RSE052—52-ball VFRBGA 6.0 x 5.0 mm            Refreshed DNU/RFU/NC definitions</p>
*K	—	RYSU	08/27/2010	<p>Valid Combinations:            Corrected package information for S71VS128RB0AHK0L/8L (RLA056)            Corrected speed for OPNs S71VS256RD0AHK3L/BL to 108 MHz</p> <p>Connection Diagrams:            Reverted DNU balls to RFU</p> <p>Physical Dimensions:            Added diagram for RLA056</p>
*L	—	RYSU	12/09/2010	<p>Features:            Added Industrial temperature</p> <p>General Description:            Added references to S29VS_XS-R_SP, S29VS064R_XS064R_SP,            SWM032D108M3R, SWM128D108M3R</p> <p>Valid Combinations:            Added OPNs S71VS064RB0AHT3L/BL/0M/8M, S71VS128RB0AHK3L/BL,            S71VS256RD0AHK3M, S71VS256RD0AHK40/C0            Added Temperature Range Column</p>

**Document History Page (Continued)**

Document Title: S71VS/XS-R, MirrorBit® 1.8 V Simultaneous Read/Write Burst Mode Multiplexed Flash and Burst Mode pSRAM				
Document Number: 002-00377				
Rev.	ECN No.	Orig. of Change	Submission Date	Description of Change
*M	—	RYSU	04/13/2011	General Description: Removed SWM032D108M1N and SWM064D108M1N references Valid Combinations: Removed OPNs S71VS064RB0AHT3M/BM, S71VS128RB0AHK2L/AL, S71VS128RC0AHK20, S71VS128RC0ZHKxx, S71VS256RC0ZHKxx, S71VS256RD0ZHExx Physical Dimensions: Removed NLB056 and NSD056 diagrams. Added diagram for RLG052
*N	—	RYSU	06/20/2011	Valid Combinations: Added OPNs S71VS128RB0AHK4L/CL, S71VS064RB0AHT4L/CL
*O	—	RYSU	06/29/2012	Valid Combinations: Added OPNs S71VS064RB0AHT3M/BM
*P	—	RYSU	10/02/2012	Valid Combinations: Updated the S71VS256RC0AHK4L/CL package from RSD056 to RLA056.
*Q	—	RYSU	01/31/2014	General Description: Removed 128 Mb MUX pSRAM Type 5 Valid Combinations: Removed OPNs S71VS064RB0AHT0L/BL, S71VS256RD0AHK40/C0 Added OPN S71VS256RD0AHK4L/CL
*R	5175865	RYSU	03/23/2016	Updated , <a href="#">General Description on page 2</a> : Updated table for detailed specifications: Replaced “Publication Identification Number” with “Cypress Document Number” in column heading. Replaced “S29VS/XS-R” with “S29VS256R, S29VS128R datasheet” in “Document” column. Replaced “S29VS_XS-R_00” with “002-00833” in “Cypress Document Number” column. Removed “S29VS/XS-R Supplement” document and its details. Replaced “S29VS064R/XS064R” with “S29VS064R datasheet” in “Document” column. Replaced “S29VS_XS064R_00” with “002-00949” in “Cypress Document Number” column. Removed “S29VS064R/XS064R Supplement” document and its details. Updated to Cypress template.
*S	5965598	AESATMP8	11/13/2017	Updated logo and Copyright.

## Sales, Solutions, and Legal Information

### Worldwide Sales and Design Support

Cypress maintains a worldwide network of offices, solution centers, manufacturer's representatives, and distributors. To find the office closest to you, visit us at [Cypress Locations](#).

#### Products

ARM® Cortex® Microcontrollers	<a href="http://cypress.com/arm">cypress.com/arm</a>
Automotive	<a href="http://cypress.com/automotive">cypress.com/automotive</a>
Clocks & Buffers	<a href="http://cypress.com/clocks">cypress.com/clocks</a>
Interface	<a href="http://cypress.com/interface">cypress.com/interface</a>
Internet of Things	<a href="http://cypress.com/iot">cypress.com/iot</a>
Memory	<a href="http://cypress.com/memory">cypress.com/memory</a>
Microcontrollers	<a href="http://cypress.com/mcu">cypress.com/mcu</a>
PSoC	<a href="http://cypress.com/psoc">cypress.com/psoc</a>
Power Management ICs	<a href="http://cypress.com/pmic">cypress.com/pmic</a>
Touch Sensing	<a href="http://cypress.com/touch">cypress.com/touch</a>
USB Controllers	<a href="http://cypress.com/usb">cypress.com/usb</a>
Wireless Connectivity	<a href="http://cypress.com/wireless">cypress.com/wireless</a>

#### PSoC® Solutions

[PSoC 1](#) | [PSoC 3](#) | [PSoC 4](#) | [PSoC 5LP](#) | [PSoC 6](#)

#### Cypress Developer Community

[Forums](#) | [WICED IOT Forums](#) | [Projects](#) | [Video](#) | [Blogs](#) | [Training](#) | [Components](#)

#### Technical Support

[cypress.com/support](http://cypress.com/support)

© Cypress Semiconductor Corporation, 2008-2017. This document is the property of Cypress Semiconductor Corporation and its subsidiaries, including Spansion LLC ("Cypress"). This document, including any software or firmware included or referenced in this document ("Software"), is owned by Cypress under the intellectual property laws and treaties of the United States and other countries worldwide. Cypress reserves all rights under such laws and treaties and does not, except as specifically stated in this paragraph, grant any license under its patents, copyrights, trademarks, or other intellectual property rights. If the Software is not accompanied by a license agreement and you do not otherwise have a written agreement with Cypress governing the use of the Software, then Cypress hereby grants you a personal, non-exclusive, nontransferable license (without the right to sublicense) (1) under its copyright rights in the Software (a) for Software provided in source code form, to modify and reproduce the Software solely for use with Cypress hardware products, only internally within your organization, and (b) to distribute the Software in binary code form externally to end users (either directly or indirectly through resellers and distributors), solely for use on Cypress hardware product units, and (2) under those claims of Cypress's patents that are infringed by the Software (as provided by Cypress, unmodified) to make, use, distribute, and import the Software solely for use with Cypress hardware products. Any other use, reproduction, modification, translation, or compilation of the Software is prohibited.

TO THE EXTENT PERMITTED BY APPLICABLE LAW, CYPRESS MAKES NO WARRANTY OF ANY KIND, EXPRESS OR IMPLIED, WITH REGARD TO THIS DOCUMENT OR ANY SOFTWARE OR ACCOMPANYING HARDWARE, INCLUDING, BUT NOT LIMITED TO, THE IMPLIED WARRANTIES OF MERCHANTABILITY AND FITNESS FOR A PARTICULAR PURPOSE. To the extent permitted by applicable law, Cypress reserves the right to make changes to this document without further notice. Cypress does not assume any liability arising out of the application or use of any product or circuit described in this document. Any information provided in this document, including any sample design information or programming code, is provided only for reference purposes. It is the responsibility of the user of this document to properly design, program, and test the functionality and safety of any application made of this information and any resulting product. Cypress products are not designed, intended, or authorized for use as critical components in systems designed or intended for the operation of weapons, weapons systems, nuclear installations, life-support devices or systems, other medical devices or systems (including resuscitation equipment and surgical implants), pollution control or hazardous substances management, or other uses where the failure of the device or system could cause personal injury, death, or property damage ("Unintended Uses"). A critical component is any component of a device or system whose failure to perform can be reasonably expected to cause the failure of the device or system, or to affect its safety or effectiveness. Cypress is not liable, in whole or in part, and you shall and hereby do release Cypress from any claim, damage, or other liability arising from or related to all Unintended Uses of Cypress products. You shall indemnify and hold Cypress harmless from and against all claims, costs, damages, and other liabilities, including claims for personal injury or death, arising from or related to any Unintended Uses of Cypress products.

Cypress, the Cypress logo, Spansion, the Spansion logo, and combinations thereof, WICED, PSoC, CapSense, EZ-USB, F-RAM, and Traveo are trademarks or registered trademarks of Cypress in the United States and other countries. For a more complete list of Cypress trademarks, visit [cypress.com](http://cypress.com). Other names and brands may be claimed as property of their respective owners.

## Looking for pricing, stock, or lifecycle information?

Click below to explore more details on WIN SOURCE:

 [View S71VS128RC0AHKCL0 on WIN SOURCE](#)

 [Cypress Semiconductor Corp](#) Information

## Optimize Your Supply Chain with WIN SOURCE Solutions

-  Global Sourcing Solution
-  Obsolete Management
-  Cost Control Management
-  Shortage Management
-  Alternative Solution
-  Excess Inventory Management