

Low-Power Quad-Channel Microphone ADC with TDM Output

Analog Input and ADC Features

- 91-dB dynamic range (A-weighted) @ 0-dB gain
- -84-dB THD+N @ 0-dB gain
- Four fully differential inputs: Four analog mic/line inputs
- Four analog programmable gain amplifiers
 - -6 to +12 dB, in 0.5-dB steps
 - +10 or +20 dB boost for mic input
- Four mic bias generators
- MUTE pin for quick mic mute and programmable quick power down

Digital Processing Features

- Volume control, mute, programmable high-pass filter, noise gate
- Two digital mic (DMIC) interfaces

Digital Output Features

- Two DMIC SCLK generators
- Four-channel I²S output or TDM output. Four CS53L30s can be used to output 16 channels of 24-bit 16-kHz sample rate data on a single TDM line.

System Features

- Native (no PLL required) support for 6-/12-MHz, 6.144-/12.288-MHz, 5.6448-/11.2896-MHz, or 19.2-MHz master clock rates and 8- to 48-kHz audio sample rates
- Master or Slave Mode. Clock dividers can be used to generate common audio clocks from single-master clock input.
- Low power consumption
 - Less than 4.5-mW stereo (16 kHz) analog mic record
 - Less than 2.5-mW mono (8 kHz) analog mic record
- Selectable mic bias and digital interface logic voltages
- High-speed (400-kHz) I²C control port
- Available in 30-ball WLCSP and 32-pin QFN

Applications

- Voice-recognition systems
- Advanced headsets and telephony systems
- Voice recorders
- Digital cameras and video cameras

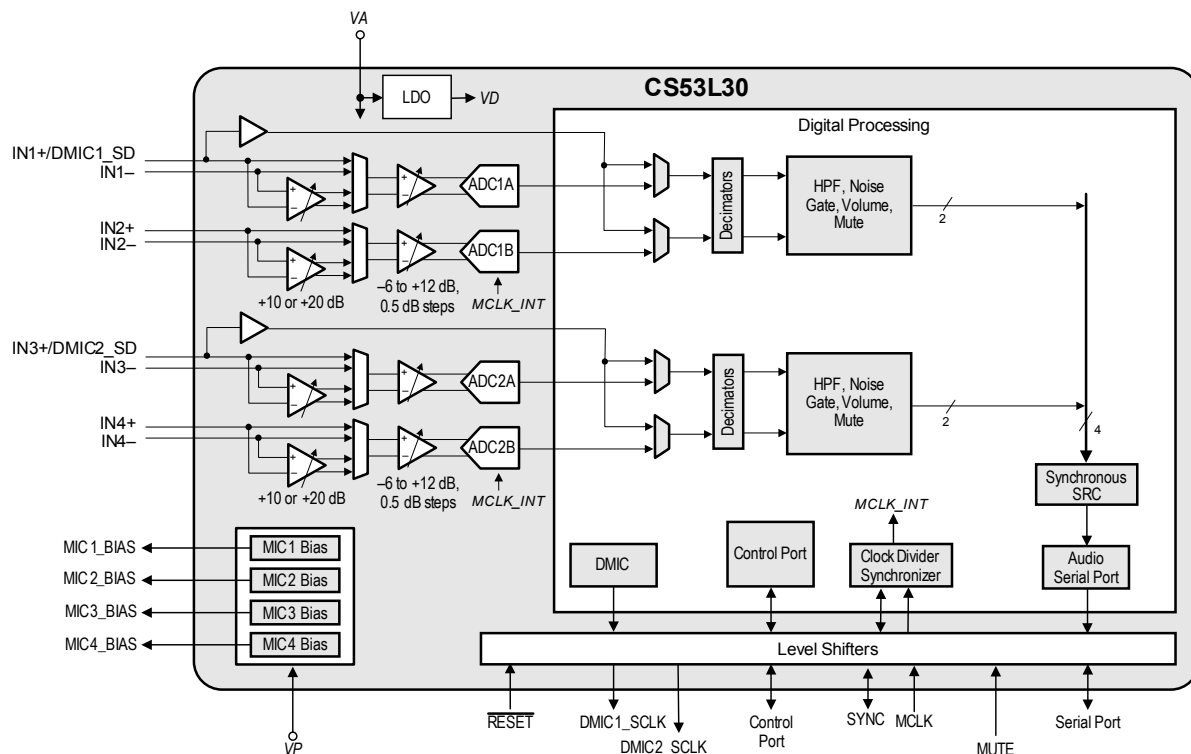

General Description

The CS53L30 is a high-performance, low-power, quad-channel ADC. It is designed for use in multiple-mic applications while consuming minimal board space and power.

The flexible ADC inputs can accommodate four channels of analog mic or line-input data in differential, pseudodifferential, or single-ended mode, or four channels of digital mic data. The analog input path includes a +10- to +20-dB boost and a -6- to +12-dB PGA. Digital mic data bypasses the analog gain circuits and is fed directly to the decimators.

Four mic bias generators are integrated into the device. The device also includes two digital mic serial clock outputs.

The CS53L30 includes several digital signal processing features such as high-pass filters, noise gate, and volume control.

The device can output its four channels of audio data over two I²S ports or a single TDM port. Additionally, up to four CS53L30s can be used to output up to 16 channels of data over a single TDM line. This is done by setting the appropriate frame slots for each device, and each device then alternates between outputting data and setting the output pin to high impedance.

The CS53L30 can operate as a serial port clock master or slave. In Master Mode, clock dividers are used to generate the internal master clock and audio clocks from either the 6-/12-MHz, 6.144-/12.288-MHz, 5.6448-/11.2896-MHz, or 19.2-MHz master clock.

The device is powered from VA, a 1.8-V nominal supply and VP, a typical battery supply. An internal LDO on the VA supply powers the device's digital core. The VP supply powers the mic bias generators and the AFE.

The CS53L30 is controlled by an I²C control port. A reset pin is also included. The device is available in a 30-ball 0.4-mm pitch WLCSP package and 32-pin 5 x 5-mm QFN package.

Table of Contents

1 Pin Descriptions	4	7 Register Descriptions	47
1.1 WLCSP	4	7.1 Device ID A and B	47
1.2 QFN	5	7.2 Device ID C and D	47
1.3 Pin Descriptions	5	7.3 Device ID E	47
2 Typical Connection Diagram	7	7.4 Revision ID	47
3 Characteristics and Specifications	9	7.5 Power Control	47
Table 3-1. Recommended Operating Conditions	9	7.6 MCLK Control	48
Table 3-2. Absolute Maximum Ratings	9	7.7 Internal Sample Rate Control	48
Table 3-3. Combined ADC On-Chip Analog, Digital Filter, SRC, and DMIC Characteristics	9	7.8 Mic Bias Control	49
Table 3-4. ADC High-Pass Filter (HPF) Characteristics	9	7.9 ASP Configuration Control	49
Table 3-5. Analog-Input-to-Serial-Port Characteristics	10	7.10 ASP Control 1	49
Table 3-6. MIC BIAS Characteristics	11	7.11 ASP TDM TX Control 1–4	50
Table 3-7. Power-Supply Rejection Ratio (PSRR) Characteristics	11	7.12 ASP TDM TX Enable 1–6	50
Table 3-8. Power Consumption	12	7.13 ASP Control 2	50
Table 3-9. Switching Specifications—Digital Mic Interface	14	7.14 Soft Ramp Control	50
Table 3-10. Specifications—I ² S	14	7.15 LRCK Control 1	51
Table 3-11. Switching Specifications—Time-Division Multiplexed (TDM) Mode	15	7.16 LRCK Control 2	51
Table 3-12. Switching Specifications—I ² C Control Port	16	7.17 MUTE Pin Control 1	51
Table 3-13. Digital Interface Specifications and Characteristics	17	7.18 MUTE Pin Control 2	51
Table 3-14. Thermal Overload Detection Characteristics	17	7.19 Input Bias Control 1	52
4 Functional Description	18	7.20 Input Bias Control 2	52
4.1 Overview	18	7.21 DMIC1 Stereo Control	52
4.2 Resets	19	7.22 DMIC2 Stereo Control	52
4.3 Interrupts	19	7.23 ADC1/DMIC1 Control 1	52
4.4 Capture-Path Inputs	20	7.24 ADC1/DMIC1 Control 2	53
4.5 Digital Microphone (DMIC) Interface	23	7.25 ADC1 Control 3	53
4.6 Serial Ports	25	7.26 ADC1 Noise Gate Control	54
4.7 TDM Mode	29	7.27 ADC1A/1B AFE Control	54
4.8 Synchronous Sample-Rate Converter (SRC)	33	7.28 ADC1A/1B Digital Volume	54
4.9 Multichip Synchronization Protocol	34	7.29 ADC2/DMIC2 Control 1	55
4.10 Input Path Source Selection and Powering	34	7.30 ADC2/DMIC2 Control 2	55
4.11 Thermal Overload Notification	34	7.31 ADC2 Control 3	55
4.12 MUTE Pin	35	7.32 ADC2 Noise Gate Control	56
4.13 Power-Up and Power-Down Control	35	7.33 ADC2A/2B AFE Control	56
4.14 I ² C Control Port	35	7.34 ADC2A/2B Digital Volume	56
4.15 QFN Thermal Pad	37	7.35 Device Interrupt Mask	57
5 Systems Applications	37	7.36 Device Interrupt Status	57
5.1 Octal Microphone Array to the Audio Serial Port	38	8 Parameter Definitions	58
5.2 Power-Up Sequence	39	9 Plots	58
5.3 Power-Down Sequence	41	9.1 Digital Filter Response	58
5.4 Capture-Path Inputs	42	9.2 PGA Gain Linearity	62
5.5 MCLK Jitter	44	9.3 Dynamic Range Versus Sampling Frequency	63
5.6 Frequency Response Considerations	44	9.4 FFTs	63
5.7 Connecting Unused Pins	44	10 Package Dimensions	65
6 Register Quick Reference	45	10.1 WLCSP Package	65
		10.2 QFN Package	66
		11 Thermal Characteristics	66
		12 Ordering Information	66
		13 Revision History	67

1 Pin Descriptions

1.1 WLCSP

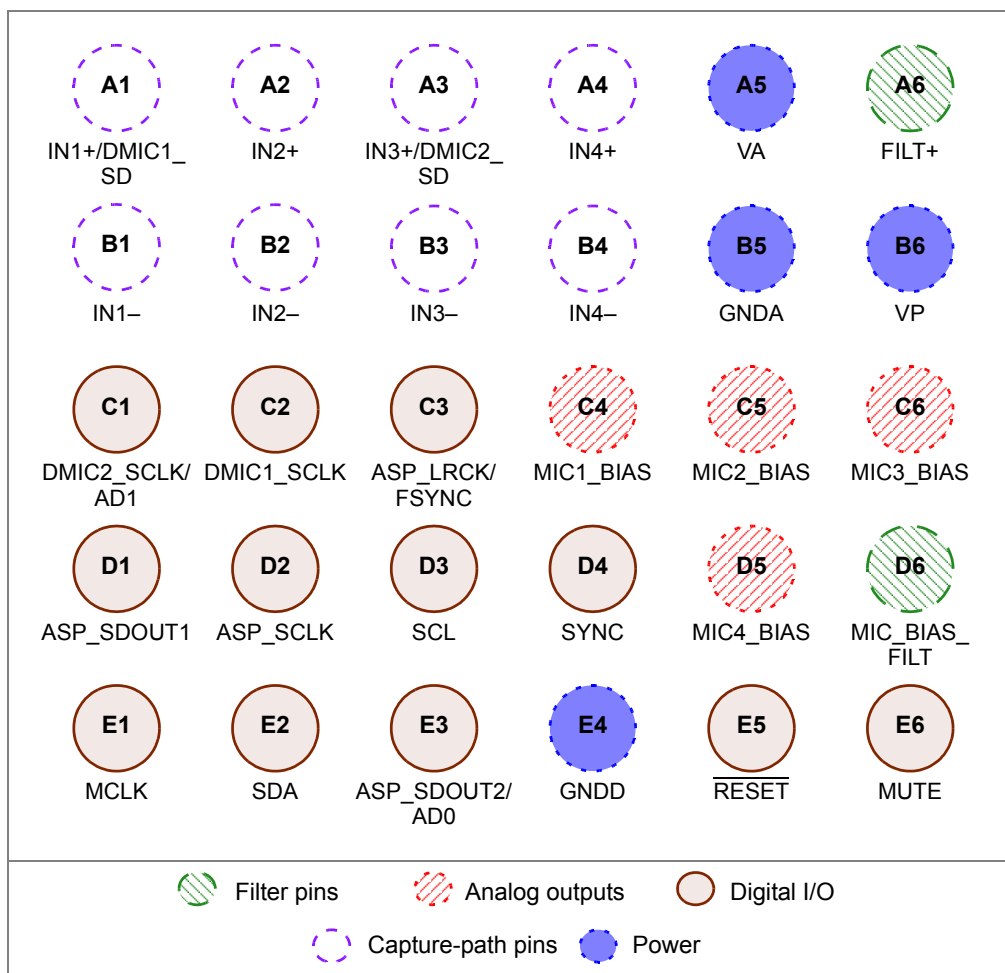

Figure 1-1. Top-Down (Through-Package) View—30-Ball WLCSP Package

1.2 QFN

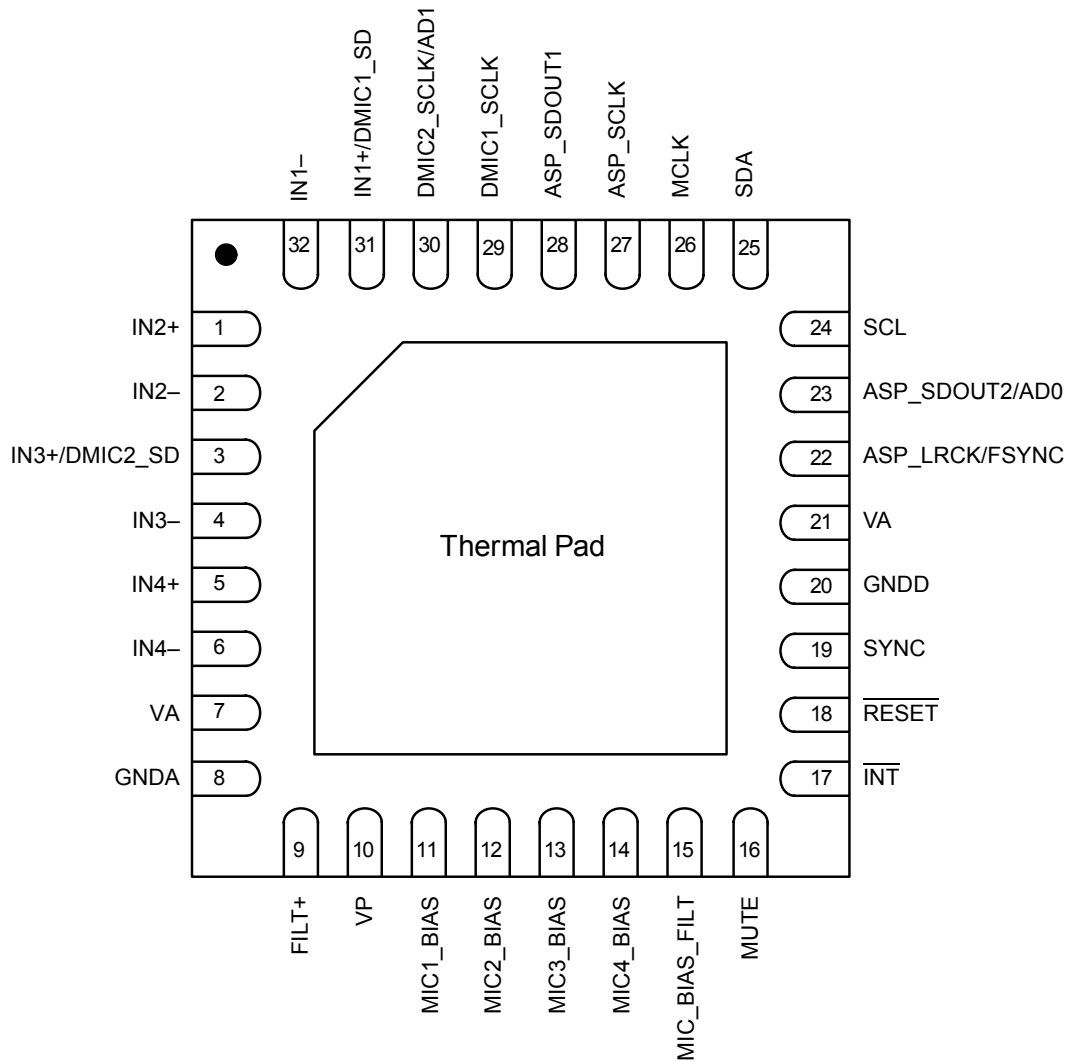

Figure 1-2. Top-Down (Through-Package) View—32-Pin QFN Package

1.3 Pin Descriptions

Table 1-1. Pin Descriptions

Name	Ball #	Pin #	Power Supply	I/O	Description	Internal Connection	Driver	Receiver	State at Reset
Capture-Path Pins 									
IN1+/DMIC1_SD	A1	31	VA	I	Noninverting Inputs/DMIC Inputs. Positive analog inputs for the stereo ADCs when CH_TYPE = 0 (default) or DMIC inputs when CH_TYPE = 1.	Programmable	—	Hysteresis on CMOS input	—
IN2+	A2	1							
IN3+/DMIC2_SD	A3	3							
IN4+	A4	5							
IN1-	B1	32	VA	I	Inverting Inputs. Negative analog inputs for the stereo ADCs when CH_TYPE = 0 (default) or unused when CH_TYPE = 1.	Programmable	—	Hysteresis on CMOS input	—
IN2-	B2	2							
IN3-	B3	4							
IN4-	B4	6							

Table 1-1. Pin Descriptions (Cont.)



Name	Ball #	Pin #	Power Supply	I/O	Description	Internal Connection	Driver	Receiver	State at Reset
Filter pins 									
MIC_BIAS_FILT	D6	15	VP	I	Microphone Bias Voltage Filter. Filter connection for the internal quiescent voltage used for the MICx_BIAS outputs.	—	—	—	—
FILT+	A6	9	VA	O	Positive Reference Filter. Positive reference voltage filter for internal sampling circuits.	—	—	—	—
Analog Outputs 									
MIC1_BIAS MIC2_BIAS MIC3_BIAS MIC4_BIAS	C4 C5 C6 D5	11 12 13 14	VP	O	Microphone Bias Voltage. Low-noise bias supply for an external mic.	—	—	—	Hi-Z
Digital I/O 									
$\overline{\text{INT}}$	—	17	VA	O	Interrupt. Outgoing interrupt signal generated upon registering an error (fault).	—	CMOS open-drain output	—	Hi-Z
$\overline{\text{RESET}}$	E5	18	VA	I	Reset. The device enters a low power mode when this pin is driven low.	—	—	Hysteresis on CMOS input	—
SYNC	D4	19	VA	I/O	Multidevice Synchronization Signal. Synchronization output when SYNC_EN is set, otherwise it is a synchronization input. Defaults to input.	Weak pulldown	CMOS output	Hysteresis on CMOS input	Hi-Z
SCL	D3	24	VA	I	Serial Control Port Clock. Serial clock for the I ² C port.	—	—	Hysteresis on CMOS input	—
SDA	E2	25	VA	I/O	Serial Control Data. Bidirectional data pin for the I ² C port.	—	CMOS open-drain output	Hysteresis on CMOS input	—
MCLK	E1	26	VA	I	Master Clock. Clock source for device's core.	Weak pulldown	—	Hysteresis on CMOS input	—
ASP_SCLK	D2	27	VA	I/O	Audio Serial Clock. Audio bit clock. Input in Slave Mode, output in Master Mode.	Weak pulldown	CMOS output	Hysteresis on CMOS input	Hi-Z
ASP_LRCK/ FSYNC	C3	22	VA	I/O	Audio Left/Right Clock/Frame SYNC. Identifies the start of each serialized PCM data word and indicates the active channel on each serial PCM audio data line. Input in Slave Mode, output in Master Mode.	Weak pulldown	CMOS output	Hysteresis on CMOS input	Hi-Z
ASP_SDOUT1	D1	28	VA	O	Audio Data Output. Output for the two's complement serial PCM data. Channels 1 and 2 are output in I ² S Mode, while all four channels of data are output on this single pin in TDM Mode.	Weak pulldown	Tristateable CMOS output	—	Hi-Z
ASP_SDOUT2/ AD0	E3	23	VA	I/O	Audio Data Output/Address Select. Output for the two's-complement serial PCM data. Channels 3 and 4 are output in I ² S Mode. Along with DMIC2_SCLK/AD1, immediately sets the I ² C address when RESET is deasserted. Default is 0.	Weak pulldown	Tristateable CMOS output	—	Hi-Z
DMIC1_SCLK	C2	29	VA	O	Digital MIC Interface 1 Serial Clock. High speed clock output to the digital mics.	Weak pulldown	CMOS output	—	Hi-Z

Table 1-1. Pin Descriptions (Cont.)

Name	Ball #	Pin #	Power Supply	I/O	Description	Internal Connection	Driver	Receiver	State at Reset
DMIC2_SCLK/AD1	C1	30	VA	I/O	Digital MIC Interface 2 Serial Clock/ Address Select. High speed clock output to the digital mics. Along with ASP_SDOOUT2/AD0, immediately sets the I ² C address when RESET is deasserted. Default is 0.	Weak pulldown	CMOS output	—	Hi-Z
MUTE	E6	16	VA	I	Mute. Asserting this pin mutes all four channels. Also can be programmed to power down modules as configured in the MUTE pin control registers.	Weak pulldown	—	Hysteresis on CMOS input	—
Power									
VA	A5	7 21	N/A	I	Analog/Digital Power. Power supply for analog circuitry and digital circuitry via internal LDO.	—	—	—	—
VP	B6	10	N/A	I	Analog Power. Power supply for mic bias.	—	—	—	—
GNDA	B5	8	N/A	I	Analog Ground. Ground reference.	—	—	—	—
GNDD	E4	20	N/A	I	Digital Ground. Ground reference.	—	—	—	—

2 Typical Connection Diagram

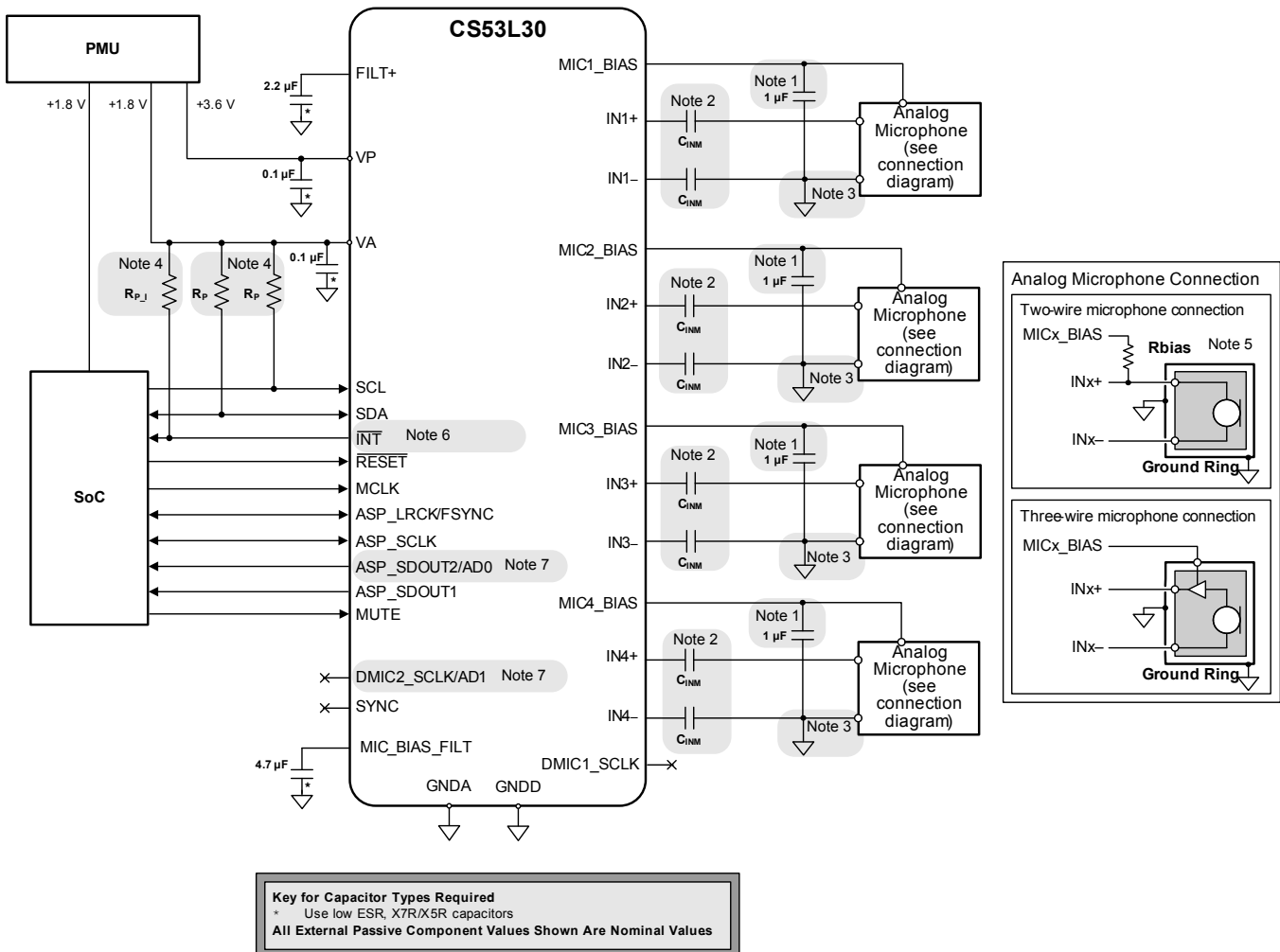

Figure 2-1. Typical Connection Diagram—Analog Microphone Connections

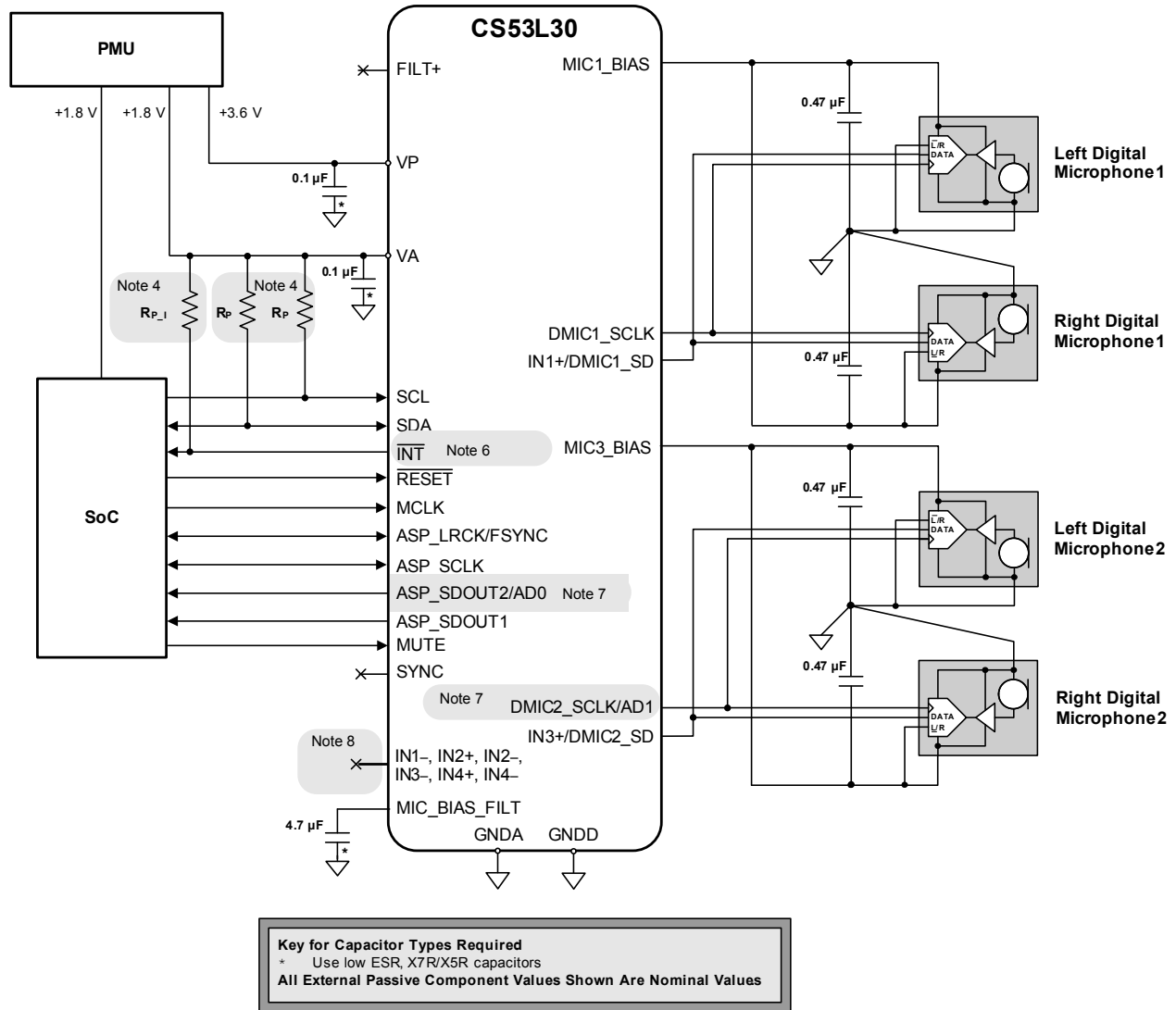

Figure 2-2. Typical Connection Diagram—Digital Microphone Connections

1. The MIC_x_BIAS compensation capacitor must be 1 μF (nominal values indicated, can vary from the nominal by ±20%). This value is bounded by the stability of the amplifier and the maximum rise-time specification of the output.
2. The DC-blocking capacitor, C_{INM}, forms a high-pass filter whose corner frequency is determined by the capacitor value and the input impedance. See [Table 3-5](#) and [Section 4.4.2](#).
3. The reference terminal of the IN_x inputs connects to the ground pin of the mic cartridge in the pseudodifferential case. In a fully differential configuration, the reference terminal of the IN_x inputs connects to the inverting output terminal of differential mic.
4. R_{P1} and R_P can be calculated by using the values in [Table 3-14](#).
5. The value of R_{BIAS}, the bias resistor for electret condenser mics, is dictated by the mic cartridge.
6. The INT pin is provided only on the QFN package.
7. ASP_SDOUT2/AD0 and DMIC2_SCLK/AD1 have internal pull-downs that allow for the default I²C address with no external components. See [Table 3-14](#) for typical and maximum pull-down values. If an I²C physical address other than the default is desired, then external resistor termination to VA is required. The minimum value resistor allowed on these I/O pins is 10 kΩ. The time constant resulting from the pull-up/pull-down resistor and the total net capacitance should be considered when determining the time required for the pin voltage to settle before RESET is deasserted.
8. Unconnected IN_x pins can be terminated with an internal weak_vcm or weak pull-down by setting the termination in the IN_{xy}_BIAS bits. See [Section 5.7](#), [Section 7.19](#), and [Section 7.20](#).

3 Characteristics and Specifications

Section 8 provides additional details about parameter definitions.

Table 3-1. Recommended Operating Conditions

Test conditions: GNDA = GNDD = 0 V; all voltages are with respect to ground.

Parameters ¹		Symbol	Min	Max	Unit
DC power supply	Analog/Digital	VA	1.71	1.89	V
	VP_MIN = 1	VP	3.2	5.25	V
	VP_MIN = 0		3.0	5.25	V
External voltage applied to pin ²	VA domain pins	V _{IN-AI}	-0.3	VA + 0.3	V
	VP domain pins	V _{IN-PI}	-0.3	VP + 0.3	V
Ambient temperature	Commercial	T _A	-10	+70	°C

1. Device functional operation is guaranteed within these limits; operation outside them is not guaranteed or implied and may reduce device reliability.
2. The maximum over/under voltage is limited by the input current.

Table 3-2. Absolute Maximum Ratings

Test conditions: GNDA = GNDD = 0 V; all voltages are with respect to ground.

Parameters		Symbol	Min	Max	Units
DC power supply	Analog/digital	VA	-0.3	2.22	V
	Mic bias	VP	-0.3	5.6	V
Input current ¹		I _{in}	—	±10	mA
Ambient operating temperature (power applied)		T _A	-50	+115	°C
Storage temperature (no power applied)		T _{stg}	-65	+150	°C

CAUTION: Operation at or beyond these limits may permanently damage the device.

1. Any pin except supplies. Transient currents of up to ±100 mA on the capture-path pins do not cause SCR latch-up.

Table 3-3. Combined ADC On-Chip Analog, Digital Filter, SRC, and DMIC Characteristics

Test conditions (unless otherwise specified): T_A = +25°C; MCLK = 12.288 MHz; characteristics do not include the effects of external AC-coupling capacitors. Path is INx to SDOUT. Analog and digital gains are all set to 0 dB; HPF disabled.

Parameters ¹		Min	Typ	Max	Units	
F _{Sint} = F _{Sext} = F _s = 48 kHz [2]	ADC notch filter on (ADCx_NOTCH_ DIS = 0)	Passband -0.05-dB corner	—	0.391	—	F _s
		Passband -3.0-dB corner	—	0.410	—	F _s
		Passband ripple (0 Hz to 0.394 F _s ; normalized to 0 Hz)	-0.13	—	0.14	dB
		Stopband @ -70 dB	—	0.492	—	F _s
	Total group delay	—	15.3/F _{Sint} + 6.5/F _{Sext}	—	s	
	ADC notch filter off (ADCx_NOTCH_ DIS = 1)	Passband -0.05-dB corner	—	0.445	—	F _s
		Passband -3.0-dB corner	—	0.470	—	F _s
		Passband ripple (0 Hz to 0.447 F _s ; normalized to 0 Hz)	-0.09	—	0.14	dB
		Stopband @ -70 dB	—	0.639	—	F _s
	Total group delay	—	15.5/F _{Sint} + 6.6/F _{Sext}	—	s	

1. Specifications are normalized to F_s and can be denormalized by multiplying by F_s.
2. See Section 5.6 for information about combined filter response when F_{Sint} is not equal to F_{Sext}.

Table 3-4. ADC High-Pass Filter (HPF) Characteristics

Test conditions (unless specified otherwise): Analog and digital gains are all set to 0 dB; ADCx_HPFCF = 00.

Parameters ¹		Min	Typ	Max	Units
Passband ²	-0.05-dB corner	—	3.57x10 ⁻⁴	—	F _{Sint}
	-3.0-dB corner	—	3.88x10 ⁻⁵	—	F _{Sint}
Passband ripple (0.417x10 ⁻³ F _s to 0.417 F _s ; normalized to 0.417 F _s)		—	—	0.01	dB
Phase deviation @ 0.453 x 10 ⁻³ F _s		—	4.896	—	°
Filter settling time ³	ADCx_HPFCF = 00 (3.88 x 10 ⁻⁵ x F _{Sint} mode)	—	12260/F _{Sint}	—	s
	ADCx_HPFCF = 01 (2.5 x 10 ⁻³ x F _{Sint} mode)	—	200/F _{Sint}	—	s
	ADCx_HPFCF = 10 (4.9 x 10 ⁻³ x F _{Sint} mode)	—	100/F _{Sint}	—	s
	ADCx_HPFCF = 11 (9.7 x 10 ⁻³ x F _{Sint} mode)	—	50/F _{Sint}	—	s

1. Response scales with F_{Sint}. Specifications are normalized to F_{Sint} and are denormalized by multiplying by F_{Sint}.
2. Characteristics do not include effects of the analog HPF filter formed by the external AC-coupling capacitors and the input impedance.
3. Required time for the magnitude of the DC component present at the output of the HPF to reach 5% of the applied DC signal.

Table 3-5. Analog-Input-to-Serial-Port Characteristics

Test conditions (unless otherwise specified): Fig. 2-1 shows CS53L30 connections; input is a full-scale 1-kHz sine wave; ADCx_PREAMP = +10 dB; ADCx_PGA_VOL = 0 dB; GNDA = GNDD = 0; voltages are with respect to ground; parameters can vary with VA, typical performance data taken with VA = 1.8 V, VP = 3.6 V, min/max performance data taken with VA = 1.8 V, VP = 3.6 V; TA = +25°C; measurement bandwidth is 20 Hz–20 kHz; LRCK = Fs = 48 kHz.

Parameters 1		Min	Typ	Max	Units	
Dynamic range 2	Preamp setting: Bypass, PGA setting: 0 dB	A-weighted unweighted	87 85	93 91	— —	dB dB
	Preamp setting: Bypass, PGA setting: +12 dB	A-weighted unweighted	80 78	86 84	— —	dB dB
	Preamp setting: +10 dB, PGA setting: 0 dB	A-weighted unweighted	84 82	90 88	— —	dB dB
	Preamp setting: +10 dB, PGA setting: +12 dB	A-weighted unweighted	74 72	80 78	— —	dB dB
	Preamp setting: +20 dB, PGA setting: 0 dB	A-weighted unweighted	78 76	84 82	— —	dB dB
	Preamp setting: +20 dB, PGA setting: +12 dB	A-weighted unweighted	66 64	72 70	— —	dB dB
Total harmonic distortion + noise 3	Preamp setting: Bypass, PGA setting: 0 dB	—1 dB	—	–84	–78	dB
	Preamp setting: Bypass, PGA setting: +12 dB	—1 dB	—	–80	–74	dB
	Preamp setting: +10 dB, PGA setting: 0 dB	—1 dB	—	–76	–70	dB
	Preamp setting: +10 dB, PGA setting: +12 dB	—1 dB	—	–63	–57	dB
	Preamp setting: +20 dB, PGA setting: 0 dB	—1 dB	—	–70	–64	dB
	Preamp setting: +20 dB, PGA setting: +12 dB	—1 dB	—	–62	–56	dB
Common-mode rejection 4		—	70	—	dB	
DC accuracy	Interchannel gain mismatch 5		—	±0.2	—	dB
	Gain drift 5		—	±100	—	ppm/°C
	PGA A/B gain	GMIN	–6.25	–6	–5.75	dB
		GMAX	11.75	12	12.25	dB
	ΔG	0.375	0.5	0.625	dB	
Preamp A/B gain	GMIN	9.5	10	10.5	dB	
GMAX	19.9	20	20.5	dB		
Offset error 6		—	128	—	LSB	
Phase accuracy	Multichip interchannel phase mismatch 7		—	0.5	—	°
	Interchannel phase mismatch 8		—	0.5	—	°
Input	Interchannel isolation 8	217 Hz	—	90	—	dB
		1 kHz	—	90	—	dB
		20 kHz	—	80	—	dB
	Full-scale signal input voltage 9	Preamp setting: 0 dB, PGA setting: 0 dB	0.78•VA	0.82•VA	0.88•VA	Vpp
		Preamp setting: +10 dB, PGA setting: 0 dB	—	0.258•VA	—	Vpp
Preamp setting: +10 dB, PGA setting: +12 dB		—	0.064•VA	—	Vpp	
Preamp setting: +20 dB, PGA setting: 0 dB		—	0.081•VA	—	Vpp	
Preamp setting: +20 dB, PGA setting: +12 dB	—	0.020•VA	—	Vpp		
Input impedance 10	Preamp setting: 0 dB	45	50	—	kΩ	
	Preamp setting: +10 dB or +20 dB;	0.9	1	—	MΩ	
DC voltage at INx (pin floating) 11,12	Preamp setting: Bypass	ADCx_PDN = 0	—	0.42•VA	—	V
		ADCx_PDN = 1	—	0.50•VA	—	V
	Preamp setting: +10 dB or +20 dB	ADCx_PDN = 0	—	0.39•VA	—	V
		ADCx_PDN = 1	—	0.50•VA	—	V

1. Measures are referred to the applicable typical full-scale voltages. Applies to all THD+N and dynamic range values in the table.

2. INx dynamic range test configuration (pseudodifferential) Includes noise from MICx_BIAS output (2.7-V setting) through a series 2.21-kΩ resistor connected to INx. Input signal is –60 dB down from the corresponding full-scale signal input voltage.

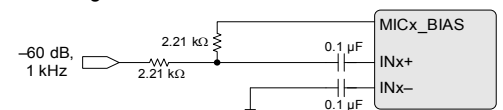

3. Input signal amplitude is relative to typical full-scale signal input voltage.

4. INx CMRR test configuration

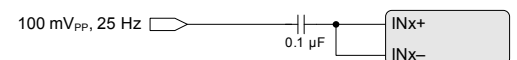

5. Measurements taken at all defined full-scale signal input voltages.

6. SDOOUT code with ADC_HPF_EN = 1, DIG_BOOSTx = 0. The offset is added at the ADC output; if two ADC sources are mixed, their offsets add.

7. Measured between two CS53L30 chips with input pairs IN1 selected and driven from same source with an MCLK of 19.2 MHz, 16-kHz sample rate, and 8-kHz full-scale sine wave with preamp gain of +20 dB and PGA gain of +12 dB.

8. Measured between input pairs (IN1 to INx, IN2 to INx, IN3 to INx, IN4 to INx) with +20 dB preamp gain and +12 dB PGA gain.

9. ADC full-scale input voltage is measured between INx+ and INx– with the preamp set to bypass and the PGA set to 0-dB gain. Maximum input signal level for INx depends on the preamp and PGA gain settings described in Section 5.4.1. The digital output level corresponding to ADC full-scale input is less than 0 dBFS due to signal attenuation through the SRC; see Table 4-4.

10. Measured between INx+ and INx–.

11. INx pins are biased as specified when weak VCM is selected in the input bias control registers; see Section 7.19 and Section 7.20.

12. Changing gain settings to Bypass Mode may cause audible artifacts due to the difference in DC operating points between modes.

Table 3-6. MIC BIAS Characteristics

Test conditions (unless otherwise specified): Fig. 2-1 shows CS53L30 connections; GNDA = GNDD = 0; all voltages are with respect to ground; VA = 1.8 V, VP = 3.6 V, TA = +25°C; only one bias output is powered up at a time; MCLK_INT_SCALE = 0.

Parameters		Min	Typ	Max	Units
Output voltage ¹	MIC_BIAS_CTRL = 01 (1.8-V mode)	1.71	1.80	1.89	V
	MIC_BIAS_CTRL = 10 (2.7-V mode)	2.61	2.75	2.86	V
Mic bias startup delay ²		—	10	—	ms
Rise time ³	I _{OUT} = 500 μA, MIC_BIAS_CTRL = 01 (1.8-V mode)	—	0.2	—	ms
	I _{OUT} = 500 μA, MIC_BIAS_CTRL = 10 (2.7-V mode)	—	0.5	—	ms
	I _{OUT} = 2 mA	—	—	3	ms
DC output current (I _{OUT})	Per output	—	—	2	mA
Integrated output noise	f = 100 Hz–20 kHz	—	3	—	μVrms
Dropout voltage ⁴		—	—	340	mV
PSRR reduction voltage ⁵		—	—	500	mV
Output resistance (R _{OUT})	I _{OUT} = 2-mA	—	30	—	Ω

- The output voltage includes attenuation due to the MIC BIAS output resistance (R_{OUT}).
- Startup delay times are approximate and vary with MCLK_{INT} frequency. If MCLK_INT_SCALE = 1, the startup delay time is scaled up by the MCLK_{INT} scaling factor. The MCLK_{INT} scaling factor is 1, 2, or 4, depending on Fs_{EXT}. See Table 4-2.
- From 10% to 90% of typical output voltage. External capacitor on MICx_BIAS is as shown in Fig. 2-1.
- Dropout voltage indicates the point where an output's voltage starts to vary significantly with reductions to its supply voltage. When the VP supply voltage drops below the programmed MICx_BIAS output voltage plus the dropout voltage, the MICx_BIAS output voltage progressively decreases as its supply decreases.
Dropout voltage is measured by reducing the VP supply until MICx_BIAS drops 10 mV from its initial voltage with the default typical test condition VP voltage (= 3.6 V, as in test conditions listed above). The difference between the VP supply voltage and the MICx_BIAS voltage at this point is the dropout voltage. For instance, if the initial MICx_BIAS output is 2.86 V when VP = 3.6 V and VP = 3.19 V when MICx_BIAS drops to 2.85 V (–10 mV), the dropout voltage is 340 mV (3.19 V – 2.85 V).
- PSRR voltage indicates the point where an output's supply PSRR starts to degrade significantly with supply voltage reductions. When the VP supply voltage drops below the programmed MICx_BIAS output voltage plus the PSRR reduction voltage, the MICx_BIAS output's PSRR progressively decreases as its supply decreases.
PSRR reduction voltage is measured by reducing the VP supply until MICx_BIAS PSRR @ 217 Hz falls below 100 dB. The difference between the VP supply voltage and the MICx_BIAS voltage at this point is the PSRR reduction voltage. For instance, if the MICx_BIAS PSRR falls to 99.9 dB when VP is reduced to 3.25 V and the MICx_BIAS output voltage is 2.75 V at that point, PSRR reduction voltage is 500 mV (3.25 V – 2.75 V).

Table 3-7. Power-Supply Rejection Ratio (PSRR) Characteristics

Test conditions (unless specified otherwise): Fig. 2-1 shows CS53L30 connections; input test signal held low (all zero data); GNDA = GNDD = 0; voltages are with respect to ground; VA = 1.8 V, VP = 3.6 V; TA = +25°C.

Parameters ¹		Min	Typical	Max	Units
INx (32-dB analog gain)	217 Hz	—	70	—	dB
	1 kHz	—	70	—	dB
	20 kHz	—	55	—	dB
MICx_BIAS (MICx_BIAS = 2.7-V mode, I _{OUT} = 500 μA)	217 Hz	—	105	—	dB
	1 kHz	—	100	—	dB
	20 kHz	—	95	—	dB
PSRR with 100-mVpp signal AC coupled to VA supply	217 Hz	—	105	—	dB
	1 kHz	—	100	—	dB
	20 kHz	—	95	—	dB
MICx_BIAS (MICx_BIAS = 2.7-V mode, I _{OUT} = 500 μA)	217 Hz	—	105	—	dB
	1 kHz	—	100	—	dB
	20 kHz	—	95	—	dB
PSRR with 100 mVpp signal AC coupled to VA supply	217 Hz	—	105	—	dB
	1 kHz	—	100	—	dB
	20 kHz	—	95	—	dB
MICx_BIAS (MICx_BIAS = 2.7-V mode, I _{OUT} = 500 μA)	217 Hz	—	90	—	dB
	1 kHz	—	90	—	dB
	20 kHz	—	70	—	dB
PSRR with 100 mVpp signal AC coupled to VP supply	217 Hz	—	90	—	dB
	1 kHz	—	90	—	dB
	20 kHz	—	70	—	dB
MICx_BIAS (MICx_BIAS = 2.7-V mode, I _{OUT} = 500 μA)	217 Hz	—	120	—	dB
	1 kHz	—	115	—	dB
	20 kHz	—	105	—	dB
PSRR with 1 Vpp signal AC coupled to VP supply	217 Hz	—	120	—	dB
	1 kHz	—	115	—	dB
	20 kHz	—	105	—	dB

- PSRR test configuration: Typical PSRR can vary by approximately 6 dB below the indicated values.

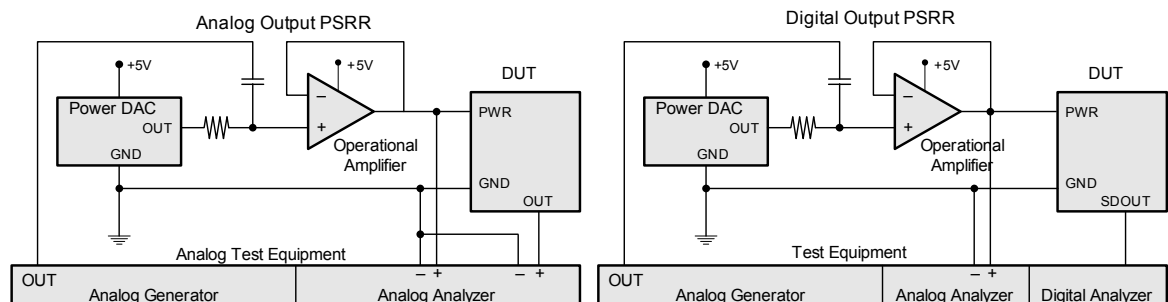

Table 3-8. Power Consumption

Test conditions (unless specified otherwise): Fig. 2-1 shows CS53L30 connections; GNDA = GNDD = 0 V; voltages are with respect to ground; performance data taken with VA = 1.8 V, VP = 3.6 V; TA = +25°C; MCLK = 12.288 MHz; serial port set to Slave Mode; digital volume = 0 dB; no signal on any input; control port inactive; MCLK_INT_SCALE = 1.

Use Cases 1 (See Table 3-9 for register field settings.)			Typical Current (μA)		Total Power (μW)	
			iVA	iVP		
1	Standby 2		2	0	4	
2	A	Quiescent 3	MCLK low, MCLK_DIS = x, PDN_ULP = 1, PDN_LP = x	7	1	17
	B		MCLK active, MCLK_DIS = 1, PDN_ULP = 1, PDN_LP = x	54	1	101
	C		MCLK low, MCLK_DIS = x, PDN_ULP = 0, PDN_LP = 1	103	19	253
	D		MCLK active, MCLK_DIS = 1, PDN_ULP = 0, PDN_LP = 1	134	19	308
3	A	Capture, analog mic input, ADCx_PREAMP = +20 dB, ADCx_PGA_VOL = +12 dB	F _{sext} = 48 kHz, mono input, MICx_BIAS_PDN = 1	1998	58	3805
	B		F _{sext} = 48 kHz, mono input, MICx_BIAS_PDN = 0	2003	147	4136
	C		F _{sext} = 16 kHz, mono input, MICx_BIAS_PDN = 1	1423	58	2770
	D		F _{sext} = 16 kHz, mono input, MICx_BIAS_PDN = 0	1432	147	3107
	E		F _{sext} = 8 kHz, mono input, MICx_BIAS_PDN = 1	1046	58	2092
	F		F _{sext} = 8 kHz, mono input, MICx_BIAS_PDN = 0	1053	147	2425
	G		F _{sext} = 48 kHz, stereo input, MICx_BIAS_PDN = 1	2697	81	5147
	H		F _{sext} = 48 kHz, stereo input, MICx_BIAS_PDN = 0	2702	243	5739
	I		F _{sext} = 16 kHz, stereo input, MICx_BIAS_PDN = 1	1955	81	3811
	J		F _{sext} = 16 kHz, stereo input, MICx_BIAS_PDN = 0	1960	243	4405
	K		F _{sext} = 8 kHz, stereo input, MICx_BIAS_PDN = 1	1494	81	2981
	L		F _{sext} = 8 kHz, stereo input, MICx_BIAS_PDN = 0	1498	243	3573
	M		F _{sext} = 48 kHz, four-channel input, MICx_BIAS_PDN = 1	4138	145	7969
	N		F _{sext} = 48 kHz, four-channel input, MICx_BIAS_PDN = 0	4141	454	9087
	O		F _{sext} = 16 kHz, four-channel input, MICx_BIAS_PDN = 1	3033	145	5981
	P		F _{sext} = 16 kHz, four-channel input, MICx_BIAS_PDN = 0	3040	454	7106
Q	F _{sext} = 8 kHz, four-channel input, MICx_BIAS_PDN = 1	2397	145	4836		
R	F _{sext} = 8 kHz, four-channel input, MICx_BIAS_PDN = 0	2403	454	5959		
4	A	Capture, analog line input, ADCx_PREAMP = 0 dB, ADCx_PGA_VOL = 0 dB	F _{sext} = 48 kHz, four-channel input, MICx_BIAS_PDN = 1	3151	145	6193
	B		F _{sext} = 16 kHz, four-channel input, MICx_BIAS_PDN = 1	2059	145	4227
	C		F _{sext} = 8 kHz, four-channel input, MICx_BIAS_PDN = 1	1429	145	3092
5	A	Capture, digital mic input	F _{sext} = 48 kHz, four-channel input, MICx_BIAS_PDN = 0	2433	352	5645
	B		F _{sext} = 16 kHz, four-channel input, MICx_BIAS_PDN = 0	1366	352	3725
	C		F _{sext} = 8 kHz, four-channel input, MICx_BIAS_PDN = 0	881	352	2852

1. Power consumption test configuration.

The current draw on the power supply pins is derived from the measured voltage drop across a 10-Ω series resistor between the associated supply source and the voltage supply pin.

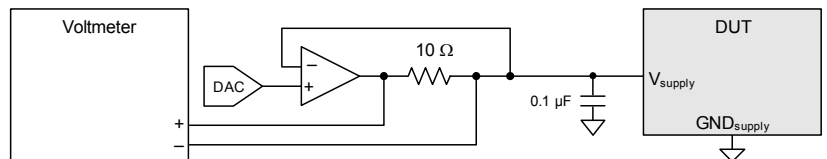

2. Standby configuration: Clock/data lines are held low; RESET = LOW; VA = 1.8 V, VP = 3.6 V

3. Quiescent configuration: data lines held low; RESET = HIGH

Table 3-9. Register Field Settings

Use Cases	Register Fields and Settings																														
	PDN_ULP	PDN_LP	MCLK_DIS	MCLK_INT_SCALE	MIC1_BIAS_PDN	MIC2_BIAS_PDN	MIC3_BIAS_PDN	MIC4_BIAS_PDN	MIC_BIAS_CTRL	ASP_RATE[3:0]	ASP_SDOUT1_PDN	ASP_SDOUT2_PDN	ASP_3ST	ADC1A_PDN	ADC1B_PDN	ADC2A_PDN	ADC2B_PDN	ADC1A_PREAMP[1:0]	ADC1A_PGA_VOL[5:0]	ADC1B_PREAMP[1:0]	ADC1B_PGA_VOL[5:0]	ADC2A_PREAMP[1:0]	ADC2A_PGA_VOL[5:0]	ADC2B_PREAMP[1:0]	ADC2B_PGA_VOL[5:0]	DMIC1_PDN	DMIC2_PDN	ASP_M/S			
1	—	—	—	—	—	—	—	—	—	—	—	—	—	—	—	—	—	—	—	—	—	—	—	—	—	—	—	—	—		
2	A	1	—	—	—	—	—	—	—	—	—	—	—	—	—	—	—	—	—	—	—	—	—	—	—	—	—	—	—		
	B	1	—	1	—	—	—	—	—	—	—	—	—	—	—	—	—	—	—	—	—	—	—	—	—	—	—	—	—		
	C	0	1	—	—	—	—	—	—	—	—	—	—	—	—	—	—	—	—	—	—	—	—	—	—	—	—	—	—		
	D	0	1	1	—	—	—	—	—	—	—	—	—	—	—	—	—	—	—	—	—	—	—	—	—	—	—	—	—		
3	A	0	0	0	—	1	1	1	1	—	1100	0	1	0	0	1	1	1	10	011000	10	011000	10	011000	10	011000	10	011000	1	1	0
	B	0	0	0	—	0	1	1	1	10	1100	0	1	0	0	1	1	1	10	011000	10	011000	10	011000	10	011000	10	011000	1	1	0
	C	0	0	0	1	1	1	1	1	—	0101	0	1	0	0	1	1	1	10	011000	10	011000	10	011000	10	011000	10	011000	1	1	0
	D	0	0	0	1	0	1	1	1	10	0101	0	1	0	0	1	1	1	10	011000	10	011000	10	011000	10	011000	10	011000	1	1	0
	E	0	0	0	1	1	1	1	1	—	0001	0	1	0	0	1	1	1	10	011000	10	011000	10	011000	10	011000	10	011000	1	1	0
	F	0	0	0	1	0	1	1	1	10	0001	0	1	0	0	1	1	1	10	011000	10	011000	10	011000	10	011000	10	011000	1	1	0
	G	0	0	0	—	1	1	1	1	—	1100	0	1	0	0	0	1	1	10	011000	10	011000	10	011000	10	011000	10	011000	1	1	0
	H	0	0	0	—	0	0	1	1	10	1100	0	1	0	0	0	1	1	10	011000	10	011000	10	011000	10	011000	10	011000	1	1	0
	I	0	0	0	1	1	1	1	1	—	0101	0	1	0	0	0	1	1	10	011000	10	011000	10	011000	10	011000	10	011000	1	1	0
	J	0	0	0	1	0	0	1	1	10	0101	0	1	0	0	0	1	1	10	011000	10	011000	10	011000	10	011000	10	011000	1	1	0
	K	0	0	0	1	1	1	1	1	—	0001	0	1	0	0	0	1	1	10	011000	10	011000	10	011000	10	011000	10	011000	1	1	0
	L	0	0	0	1	0	0	1	1	10	0001	0	1	0	0	0	1	1	10	011000	10	011000	10	011000	10	011000	10	011000	1	1	0
	M	0	0	0	—	1	1	1	1	—	1100	0	0	0	0	0	0	0	10	011000	10	011000	10	011000	10	011000	10	011000	1	1	0
	N	0	0	0	—	0	0	0	0	10	1100	0	0	0	0	0	0	0	10	011000	10	011000	10	011000	10	011000	10	011000	1	1	0
	O	0	0	0	1	1	1	1	1	—	0101	0	0	0	0	0	0	0	10	011000	10	011000	10	011000	10	011000	10	011000	1	1	0
	P	0	0	0	1	0	0	0	0	10	0101	0	0	0	0	0	0	0	10	011000	10	011000	10	011000	10	011000	10	011000	1	1	0
Q	0	0	0	1	1	1	1	1	—	0001	0	0	0	0	0	0	0	10	011000	10	011000	10	011000	10	011000	10	011000	1	1	0	
R	0	0	0	1	0	0	0	0	10	0001	0	0	0	0	0	0	0	10	011000	10	011000	10	011000	10	011000	10	011000	1	1	0	
4	A	0	0	0	—	1	1	1	1	—	1100	0	0	0	0	0	0	00	000000	00	000000	00	000000	00	000000	00	000000	1	1	0	
	B	0	0	0	1	1	1	1	—	0101	0	0	0	0	0	0	0	00	000000	00	000000	00	000000	00	000000	00	000000	1	1	0	
	C	0	0	0	1	1	1	1	—	0001	0	0	0	0	0	0	0	00	000000	00	000000	00	000000	00	000000	00	000000	1	1	0	
5	A	0	0	0	—	0	0	0	0	10	1100	0	0	0	0	0	0	—	—	—	—	—	—	—	—	—	—	0	0	0	
	B	0	0	0	1	0	0	0	0	10	0101	0	0	0	0	0	0	—	—	—	—	—	—	—	—	—	—	0	0	0	
	C	0	0	0	1	0	0	0	0	10	0001	0	0	0	0	0	0	—	—	—	—	—	—	—	—	—	—	0	0	0	

Table 3-10. Switching Specifications—Digital Mic Interface

Test conditions (unless specified otherwise): Fig. 2-1 shows CS53L30 connections; GNDA = GNDD = 0 V; voltages are with respect to ground; parameters can vary with VA, typical performance data taken with VA = 1.8 V, VP = 3.6 V, min/max performance data taken with VA = 1.8 V, VP = 3.6 V; TA = +25°C; logic 0 = ground, logic 1 = VA; DMIC_DRIVE = 0 (normal); input timings are measured at VIL and VIH thresholds, and output timings are measured at VOL and VOH thresholds (see Table 3-14).

Parameters 1,2	Symbol	Min	Max	Units
Output clock (DMICx_SCLK) frequency	1/tP	—	3.2 ^[3]	MHz
DMICx_SCLK duty cycle ⁴	—	45	55	%
DMICx_SCLK rise time (10% to 90% of VA) ⁴	t _r	—	21	ns
DMICx_SCLK fall time (90% to 10% of VA) ⁴	t _f	—	13	ns
DMICx_SD setup time before DMICx_SCLK rising edge	t _s (SD-CLKR)	10	—	ns
DMICx_SD hold time after DMICx_SCLK rising edge	t _h (CLKR-SD)	4	—	ns
DMICx_SD setup time before DMICx_SCLK falling edge	t _s (SD-CLKF)	10	—	ns
DMICx_SD hold time after DMICx_SCLK falling edge	t _h (CLKF-SD)	4	—	ns

1. Digital mic interface timing

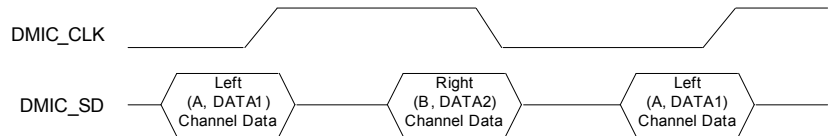

- Oversampling rate of the digital mic must match the oversampling rate of the CS53L30 internal decimators.
- The output clock frequency follows the internal MCLK rate divided by 2 or 4, as set in the ADCx/DMICx control registers (see DMIC1_SCLK_DIV on p. 53 and DMIC2_SCLK_DIV on p. 55). DMICx_SCLK is further divided by up to a factor of 4 when MCLK_INT_SCALE is set (see p. 48). MCLK source deviation from nominal supported rates is applied directly to the output clock rate by the same factor (e.g., a +100-ppm offset in the frequency of MCLK becomes a +100-ppm offset of DMICx_SCLK).
- Timing guaranteed with pull-up or pull-down resistor, with a minimum value 10 kΩ tied to DMIC2_SCLK/AD1 for I²C address determination.

Table 3-11. Specifications—I²S

Test conditions (unless specified otherwise): Fig. 2-1 shows CS53L30 connections; GNDA = GNDD = 0 V; all voltages are with respect to ground; parameters can vary with VA; typical performance data taken with VA = 1.8 V, VP = 3.6 V; min/max performance data taken with VA = 1.8 V, VP = 3.6 V; TA = +25°C; Test load for ASP_LRCK/FSYNC, ASP_SCLK, and ASP_SDOUtx CL = 60 pF; logic 0 = ground, logic 1 = VA; ASPx_DRIVE = 0; input timings are measured at VIL and VIH thresholds, and output timings are measured at VOL and VOH thresholds (see Table 3-14).

Parameters 1,2	Symbol	Min	Max	Units
MCLK frequency	—	1.024	19.2	MHz
MCLK duty cycle	—	45	55	%
Slave mode				
Input sample rate (LRCK)	F _s	(See Table 4-2)		kHz
LRCK duty cycle	—	45	55	%
SCLK frequency	1/t _P s	—	64•F _s ext	Hz
SCLK duty cycle	—	45	55	%
SCLK rising edge to LRCK edge	t _{hs} (LK-SK)	10	—	ns
LRCK setup time before SCLK rising edge	t _{ss} (LK-SK)	40	—	ns
SDOUT setup time before SCLK rising edge	t _{ss} (SDO-SK)	20	—	ns
SDOUT hold time after SCLK rising edge	t _{hs} (SK-SDO)	30	—	ns
Master mode				
Output sample rate (LRCK) All speed modes	F _s ext	(See Table 4-2)		kHz
LRCK duty cycle	—	45	55	%
SCLK frequency	1/t _P m	—	64•F _s ext	Hz
SCLK duty cycle	—	33	67	%
LRCK time before SCLK falling edge	t _{sm} (LK-SK)	-2	+2	ns
SDOUT setup time before SCLK rising edge	t _{sm} (SDO-SK)	20	—	ns
SDOUT hold time after SCLK rising edge	t _{hm} (SK-SDO)	30	—	ns

1. Serial port interface timing

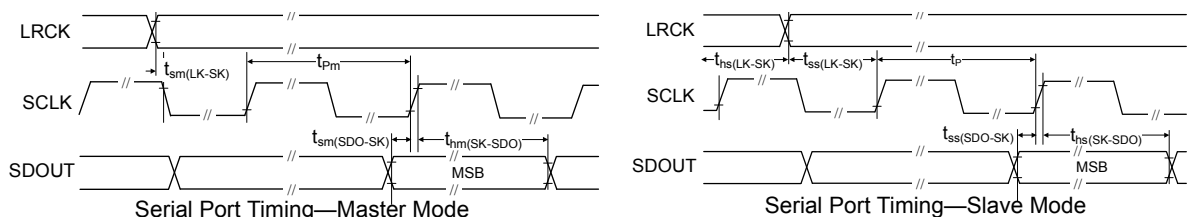

- MCLK must be stable before powering up the device. In Slave Mode, ASP_LRCK/FSYNC and ASP_SCLK must be stable before powering up the device. Before making changes to any clock setting, the device must be powered down by setting either the PDN_ULP or PDN_LP bit.

Table 3-12. Switching Specifications—Time-Division Multiplexed (TDM) Mode

Test conditions (unless specified otherwise): Fig. 2-1 shows CS53L30 connections; GNDA = GNDD = 0 V; all voltages are with respect to ground; parameters can vary with VA; typical performance data taken with VA = 1.8 V, VP = 3.6 V; min/max performance data taken with VA = 1.8 V, VP = 3.6 V; TA = +25°C; Test load for ASP_LRCK/FSYNC, ASP_SCLK, and ASP_SDOOUT1 CL = 60 pF; logic 0 = ground, logic 1 = VA; ASPx_DRIVE = 0; input timings are measured at VIL and VIH thresholds, and output timings are measured at VOL and VOH thresholds (see Table 3-14).

Parameters		Symbol	Min	Max	Units	
MCLK frequency		—	1.024	19.2	MHz	
MCLK duty cycle		—	45	55	%	
Slave mode	Input sample rate (FSYNC) 1,2	F _{s_{ext}}	—	48	kHz	
	FSYNC high time pulse 3	t _{FSYNC}	1/f _{SCLK}	(n-1)/f _{SCLK}	s	
	FSYNC setup time before SCLK rising edge	t _{SETUP1}	20	—	ns	
	SCLK frequency 4,5	f _{SCLK}	—	12.288	MHz	
	SCLK duty cycle	—	45	55	%	
	SDOUT delay time after SCLK rising edge 6	SHIFT_LEFT = 0	t _{CLK-Q1}	—	25	ns
		SHIFT_LEFT = 1	t _{CLK-Q1}	—	45	ns
SDOUT hold time of LSB before transition to Hi-Z	SHIFT_LEFT = 0 [7]	t _{HOLD2}	10	30	ns	
	SHIFT_LEFT = 1 [8]	t _{HOLD2}	10	40	ns	
Master mode	Output sample rate (FSYNC) 1	F _{s_{ext}}	—	[9]	kHz	
	FSYNC high time pulse 10	t _{FSYNC}	1/f _{SCLK}	(n-1)/f _{SCLK}	s	
	FSYNC setup time before SCLK rising edge	t _{SETUP1}	15	—	ns	
	SCLK frequency	f _{SCLK}	(See Table 4-3)		MHz	
	SCLK duty cycle	—	45	55	%	
	SDOUT delay time after SCLK rising edge	SHIFT_LEFT = 0	t _{CLK-Q1}	—	25	ns
		SHIFT_LEFT = 1	t _{CLK-Q2}	—	45	ns
SDOUT hold time of LSB before transition to Hi-Z	SHIFT_LEFT = 0 [7]	t _{HOLD2}	10	30	ns	
	SHIFT_LEFT = 1 [8]	t _{HOLD2}	10	40	ns	

1. Clock rates must be stable when the device is powered up and the serial port is not powered down. Therefore, the appropriate serial port must be powered down before any clock rates are changed.
2. Maximum frequency for the highest supported nominal rate is indicated. Table 4-2 shows nominal MCLK rates and their associated configurations.
3. "n" refers to the total number of SCLKs in one FSYNC frame.
4. If MCLK_19MHZ_EN is set, the maximum SCLK frequency is 6.4 MHz. If SHIFT_LEFT is set, the maximum SCLK frequency is 6.4 MHz.
5. SCLK frequency must be high enough to provide the necessary SCLK cycles to capture all the serial audio port bits.
6. Single-device TDM timings

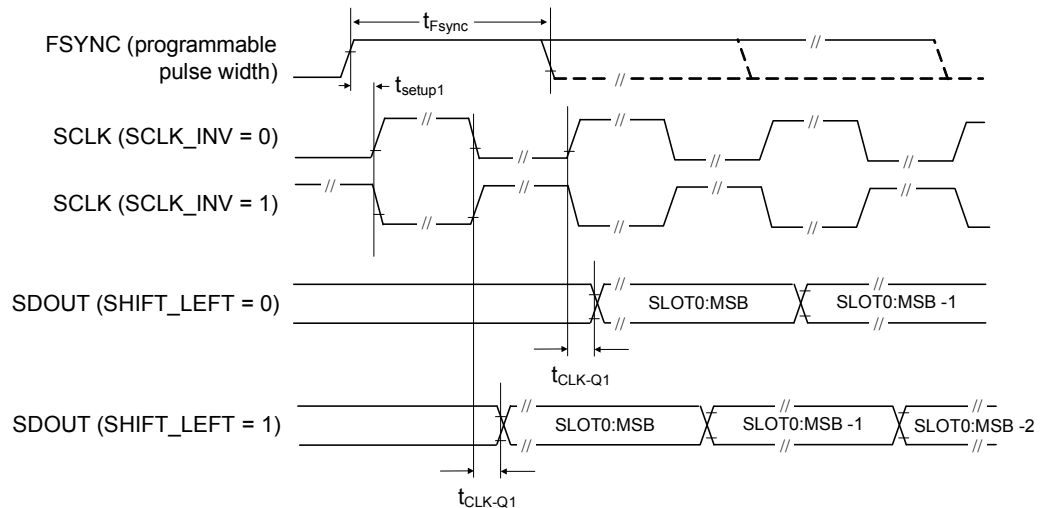

7. Hand-off timing for multidivice systems (SHIFT_LEFT = 0).

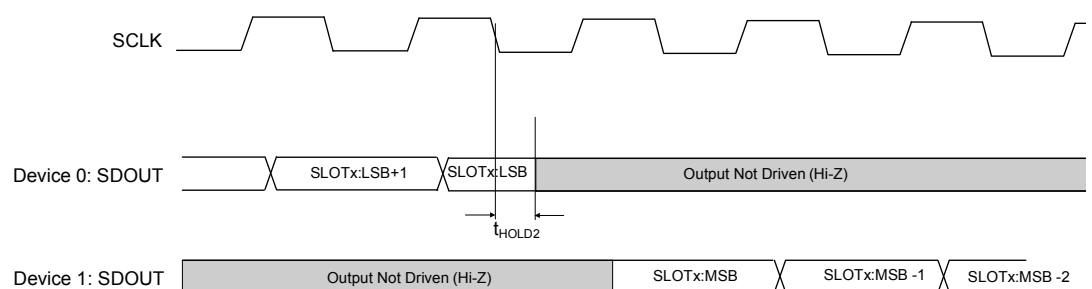

8. Hand-off timing for multidevice systems (SHIFT_LEFT = 1). When SHIFT_LEFT = 1, it is recommended to insert an empty slot between devices on the TDM bus to prevent contention possibilities.

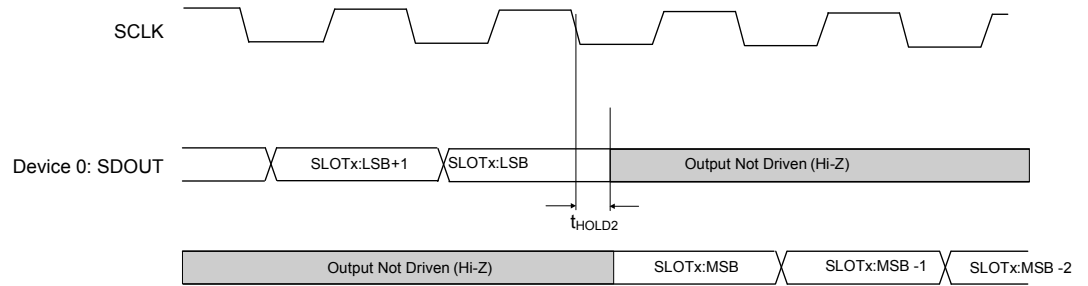

9. In Master Mode, the output sample rate follows the MCLK rate, per Section 4.6.5. MCLK deviations from the nominal supported rates are passed directly to the output sample rate by the same factor (e.g., a +100 ppm offset in the frequency of MCLK becomes a +100 ppm offset in FSYNC).

10. "n" refers to number of SCLK cycles programmed in LRCK_TPWH[10:3] | LRCK_TPWH[2:0] (see p. 51) when LRCK_50_NPW (see p. 51) is set; otherwise, t_{FSYNC} has a 50% duty cycle.

Table 3-13. Switching Specifications—I²C Control Port

Test conditions (unless specified otherwise): Fig. 2-1 shows CS53L30 connections; GNDA = GNDD = 0 V; all voltages are with respect to ground; Parameters can vary with VA, typical performance data taken with VA = 1.8 V, VP = 3.6 V, min/max performance data taken with VA = 1.8 V, VP = 3.6 V; TA = +25°C; logic 0 = ground, logic 1 = VA; input timings are measured at V_{IL} and V_{IH} thresholds, and output timings are measured at V_{OL} and V_{OH} thresholds (see Table 3-14).

Parameter 1,2	Symbol	Min	Max	Unit
RESET rising edge to start	t_{irs}	500	—	ns
SCL clock frequency	f_{scl}	—	550	kHz
Start condition hold time (prior to first clock pulse)	t_{hdst}	0.6	—	μs
Clock low time	t_{low}	1.3	—	μs
Clock high time	t_{high}	0.6	—	μs
Setup time for repeated start condition	t_{sust}	0.6	—	μs
SDA input hold time from SCL falling ³	t_{hddi}	0	0.9	μs
SDA output hold time from SCL falling	t_{hdoo}	0.2	0.9	μs
SDA setup time to SCL rising	t_{sud}	100	—	ns
Rise time of SCL and SDA	t_{rc}	—	300	ns
Fall time SCL and SDA	t_{fc}	—	300	ns
Setup time for stop condition	t_{susp}	0.6	—	μs
Bus free time between transmissions	t_{buf}	1.3	—	μs
SDA bus capacitance	C_L	—	400	pF
SDA pull-up resistance	R_p	500	—	Ω

1. All specifications are valid for the signals at the pins of the CS53L30 with the specified load capacitance.
 2. I²C control port timing.

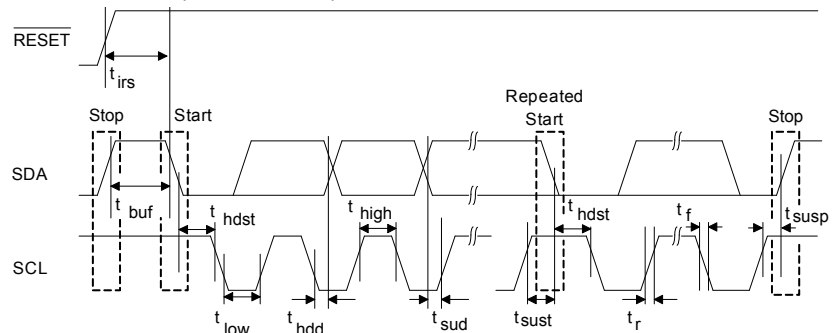

3. Data must be held for sufficient time to bridge the transition time, t_f , of SCL.

Table 3-14. Digital Interface Specifications and Characteristics

Test conditions (unless specified otherwise): Fig. 2-1 shows CS53L30 connections; GNDA = GNDD = 0 V; all voltages are with respect to ground; VA = 1.8 V, VP = 3.6 V; TA = +25°C

Parameters ¹	Symbol	Min	Max	Units
Input leakage current ² MCLK, SYNC, MUTE, all serial port inputs All control port inputs, INT, RESET	I _{in}	—	±4000 ±100	nA nA
Internal weak pull-down	—	550	2450	kΩ
Input capacitance ²	—	—	10	pF
INT current sink (V _{OL} = 0.3 V max)	—	825	—	μA
High-level output voltage ³	V _{OH}	VA – 0.2	—	V
Low-level output voltage ⁴	V _{OL}	—	0.2	V
High-level input voltage	V _{IH}	0.70•VA	—	V
Low-level input voltage	V _{IL}	—	0.30•VA	V

1. See Table 1-1 for serial and control port power rails.

2. Specification is per pin. Includes current through internal pull-down resistors on serial port.

3. I_{OH} = –100 μA for x_DRIVE = 0; I_{OH} = –67 μA for x_DRIVE = 1

4. I_{OL} = 100 μA for x_DRIVE = 0; I_{OL} = 67 μA for x_DRIVE = 1

Table 3-15. Thermal Overload Detection Characteristics

Test conditions (unless otherwise specified): GNDA = GNDD = 0; all voltages are with respect to ground; VA = 1.8 V, VP = 3.6 V.

Parameters	Min	Typ	Max	Units
Thermal overload detection threshold	—	150	—	°C

4 Functional Description

This section provides a general description of the CS53L30 architecture and detailed functional descriptions of the various blocks that comprise the CS53L30.

4.1 Overview

Fig. 4-1 is a block diagram of the CS53L30 with links to descriptions of major subblocks.

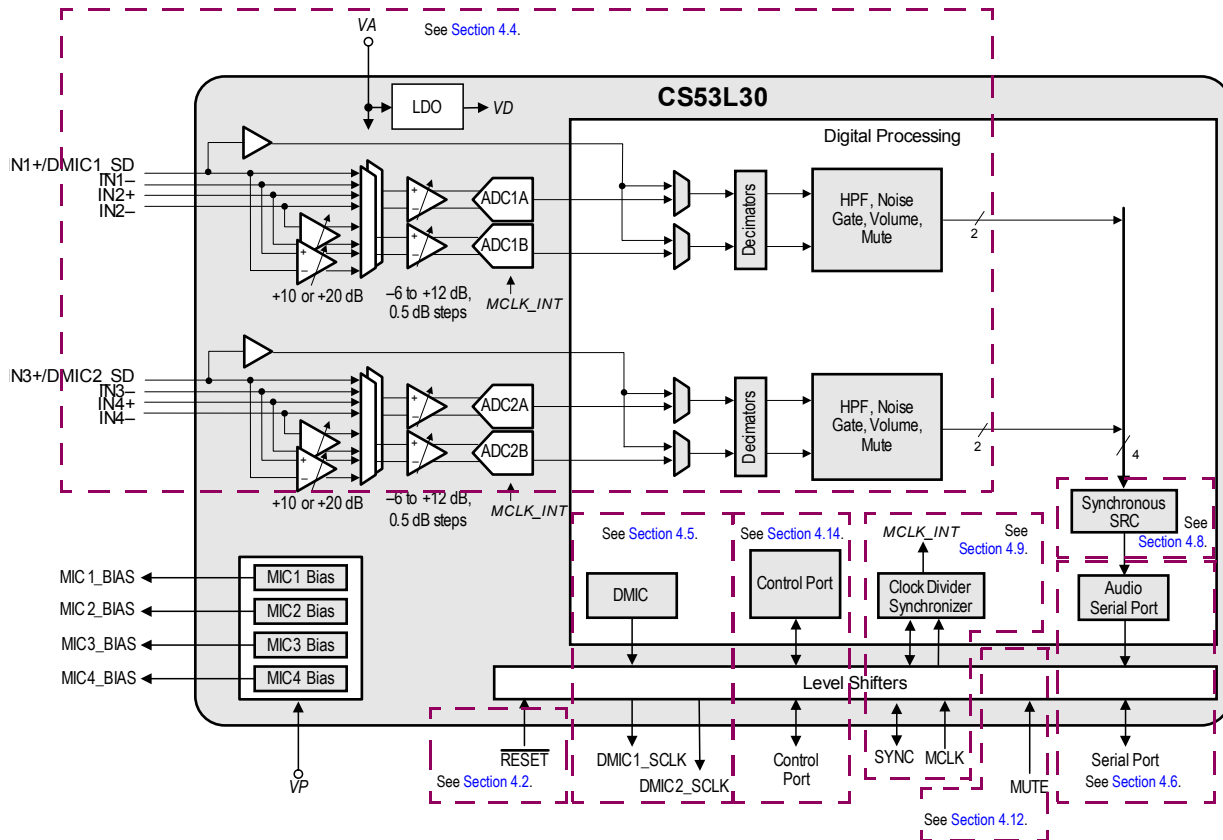

Figure 4-1. Overview of Signal Flow

The CS53L30 is a low-power, four-channel, 24-bit audio ADC. The ADCs are fed by fully differential analog inputs that support mic and line-level input signals. The ADCs are designed using multibit delta-sigma techniques. The ADCs operate at an optimal oversampling ratio balancing performance with power savings. Enhanced power savings are possible when the internal MCLK is scaled by setting `MCLK_INT_SCALE` (see p. 45). Table 4-2 lists supported sample rates with scaled internal MCLK.

The serial data port operates at a selectable range of standard audio sample rates as either timing master or slave. Core timing is flexibly sourced, without the need of a PLL, by clocks with typical audio clock rates ($N \times 5.6448$, or $N \times 6.1440$ MHz; where $N = 1$ or 2), USB rates (6 or 12 MHz), or 3G and DVB rates (19.2 MHz).

The integrated LDO regulator allows the digital core to operate at a very low voltage, significantly reducing the CS53L30's overall power consumption.

The CS53L30 can operate in a system with multiple CS53L30s to increase the number of channels available. The CS53L30s may be connected in a multidrop configuration in TDM Mode. Up to four CS53L30s can operate simultaneously on the same TDM bus. Connecting together the SYNC pins of multiple CS53L30s allows operation with minimal channel-to-channel phase mismatch across devices.

The signal to be converted can be either mic/line-level. The digital mic inputs (IN1+/DMIC1_SD, IN3+/DMIC2_SD) connect directly to the decimators.

The CS53L30 consists of the following blocks:

- Interrupts. The CS53L30 QFN package includes an open-drain, active-low interrupt output, $\overline{\text{INT}}$. [Section 4.3](#) describes interrupts.
- Capture-path inputs. The analog input block, described in [Section 4.4](#), allows selection from either analog line-level, or analog mic sources. The selected analog source is fed into a mic preamplifier (when applicable) and then into a PGA, before entering the ADC. The pseudodifferential input configuration can provide noise rejection for single-ended analog inputs. The digital mic inputs (IN1+/DMIC1_SD, IN3+/DMIC2_SD) connect directly to the decimators.
- Serial ports. The CS53L30 has either two I²S output ports or one TDM output port allowing communication to other devices in the system such as applications processors. The serial data ports are described in [Section 4.6.1](#). The TDM port allows multidrop operation (i.e., tristate capable SDOOUT driver) for sharing the TDM bus between multiple devices, and flexible data structuring via control port registers.
- Synchronous sample rate converter (SRC). The SRC, described in [Section 4.8](#), is used to bridge different sample rates at the serial port within the digital-processing core.
- Multichip synchronization protocol. Some applications require more than four simultaneous audio channels requiring multiple CS53L30s. In a subset of these multidevice applications, special attention to phase alignment of audio channels is required. The CS53L30 has a synchronization protocol to align all audio channels and minimize interchannel phase mismatch. [Section 4.9](#) describes the synchronization protocol.
- Thermal overload notification. The CS53L30 can be configured to notify the system processor that its die temperature is too high. This functionality is described in [Section 4.11](#).
- Mute pin. The CS53L30 audio outputs can be muted with the assertion of the register-programmable MUTE pin. The MUTE pin function can also be programmed to power-down ADCs, MIC_x_BIAS, etc., by setting the appropriate bits in [Section 7.17](#) and [Section 7.18](#). [Section 4.12](#) describes the MUTE pin functionality.
- Power management. Several registers provide independent power-down control of the analog and digital sections of the CS53L30, allowing operation in select applications with minimal power consumption. Power management considerations are described in [Section 4.13](#).
- Control port operation. The control port is used to access the registers allowing the CS53L30 to be configured for the desired operational modes and formats. The operation of the control port may be completely asynchronous with respect to the audio sample rates. To avoid interference problems, the control port pins must remain static if no operation is required. Control port operation is described in [Section 4.14](#).

4.2 Resets

The CS53L30 can be reset only by asserting $\overline{\text{RESET}}$. When $\overline{\text{RESET}}$ is asserted, all registers and all state machines are immediately set to their default values/states. No operation can begin until $\overline{\text{RESET}}$ is deasserted. Before normal operation can begin, $\overline{\text{RESET}}$ must be asserted at least once after the VA supply is brought up. The VP supply should be brought up before the VA supply.

4.3 Interrupts

The status of events that may require special attention is recorded in the interrupt status register (see [Section 7.36](#)). Interrupt status bits are sticky and read-to-clear: That is, once set, they remain set until the status register is read and the associated interrupt condition is no longer present.

4.3.1 Interrupt Handling with the WLCSP Package

If the WLCSP package is used, events and conditions are detected in software by polling the interrupt status register. The mask register can be ignored (see [Section 7.35](#)). Status register bits are cleared when read, as [Fig. 4-2](#) shows. If the underlying condition remains valid, the bit remains set even after the status register is read.

4.3.2 Interrupt Handling with the QFN Package

The interrupt pin ($\overline{\text{INT}}$) is implemented on the QFN package. Interrupt status bits can be individually masked by setting corresponding bits in the interrupt mask register (see Section 7.35). The configuration of mask bits determines which events cause the assertion of $\overline{\text{INT}}$:

- When an unmasked interrupt status event is detected, the status bit is set and $\overline{\text{INT}}$ is asserted.
- When a masked interrupt status event is detected, the interrupt status bit is set, but $\overline{\text{INT}}$ is not affected.

Once $\overline{\text{INT}}$ is asserted, it remains asserted until all status bits that are unmasked and set have been read. If a condition remains present and the status bit is read, although $\overline{\text{INT}}$ is deasserted, the status bit remains set.

To clear any status bits set due to the initiation of a path or block, all interrupt status bits should be read after reset and before normal operation begins. Otherwise, unmasking any previously set status bits causes $\overline{\text{INT}}$ to assert.

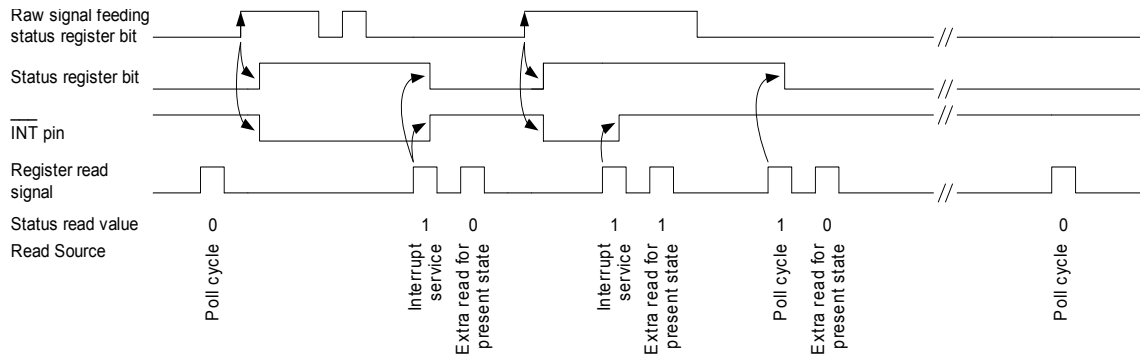

Figure 4-2. Example of Rising-Edge Sensitive, Sticky, Interrupt Status Bit Behavior ($\overline{\text{INT}}$ Pin in QFN only)

4.4 Capture-Path Inputs

This section describes the line in and mic inputs. Fig. 4-3 shows the capture-path signal flow.

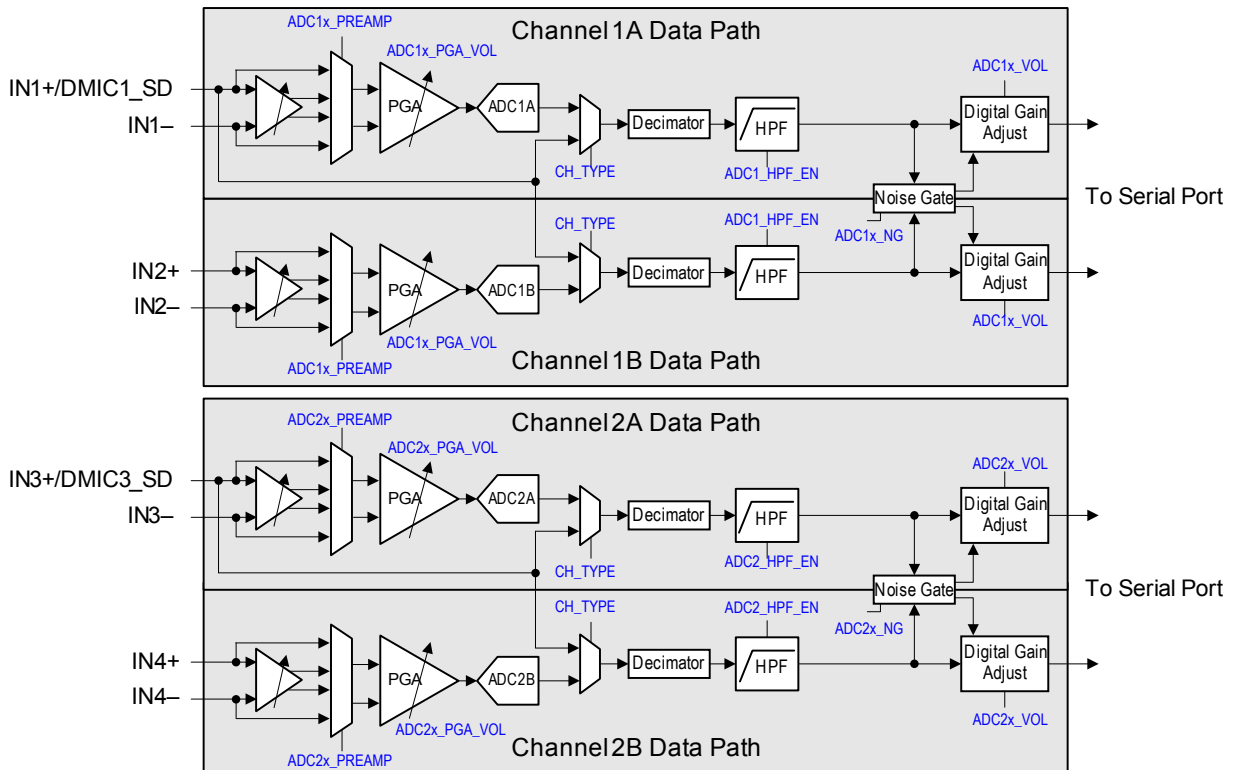
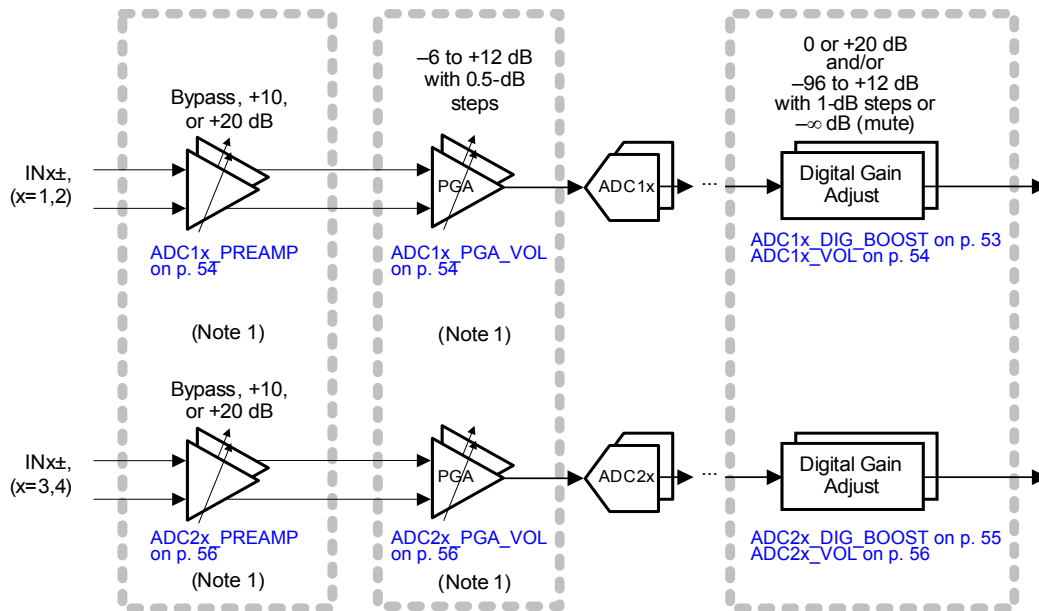

Figure 4-3. Capture-Path Signal Flow

Fig. 4-4 shows details of the various analog input gain settings, including control register fields.



1. Gains within analog blocks vary with supply voltage, with temperature, and from part to part. The gain values listed for these blocks are typical values with nominal parts and conditions.

Figure 4-4. Input Gain Paths

4.4.1 Analog Input Configurations

The CS53L30 implements fully differential analog input stages, as shown in Fig. 4-5. In addition to accepting fully differential input signals, the inputs can be used in a pseudodifferential configuration to improve common mode noise rejection with single-ended signals. In this configuration, a low-level reference signal is sensed at the ground point of the internal mic or external mic jack and used as a pseudodifferential reference for the internal input amplifiers. Sitting between the preamp and the PGA is an internal antialias filter with a first-order pole at 95 kHz and a first-order pole at 285 kHz.

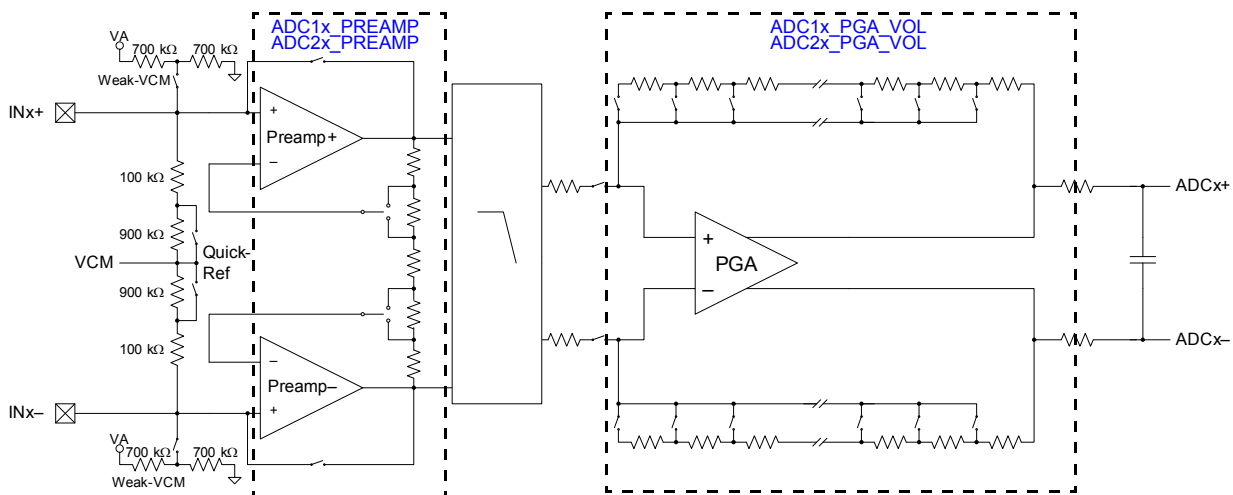

Figure 4-5. Op-Amp Level Schematic—Analog Inputs

Fig. 4-6 shows the INx interface and the related connections recommended for a fully differential internal mic. These connections are truncated in Fig. 4-6.

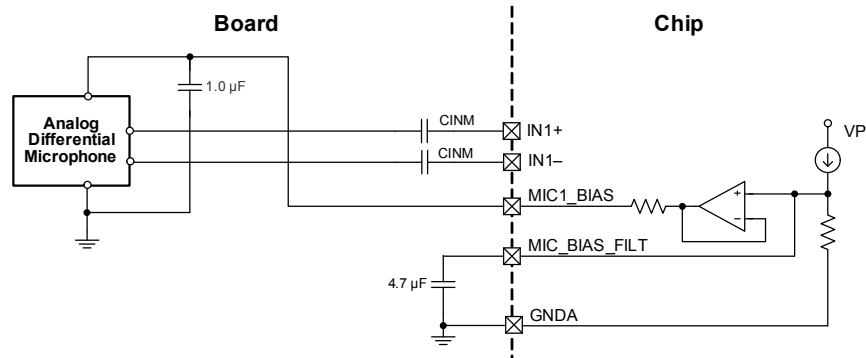

Figure 4-6. Fully Differential Mic Input Connections Example

Fig. 4-7 shows the IN1–IN4 interfaces and the related pseudodifferential connections recommended to achieve the best common-mode rejection for single-ended internal mics.

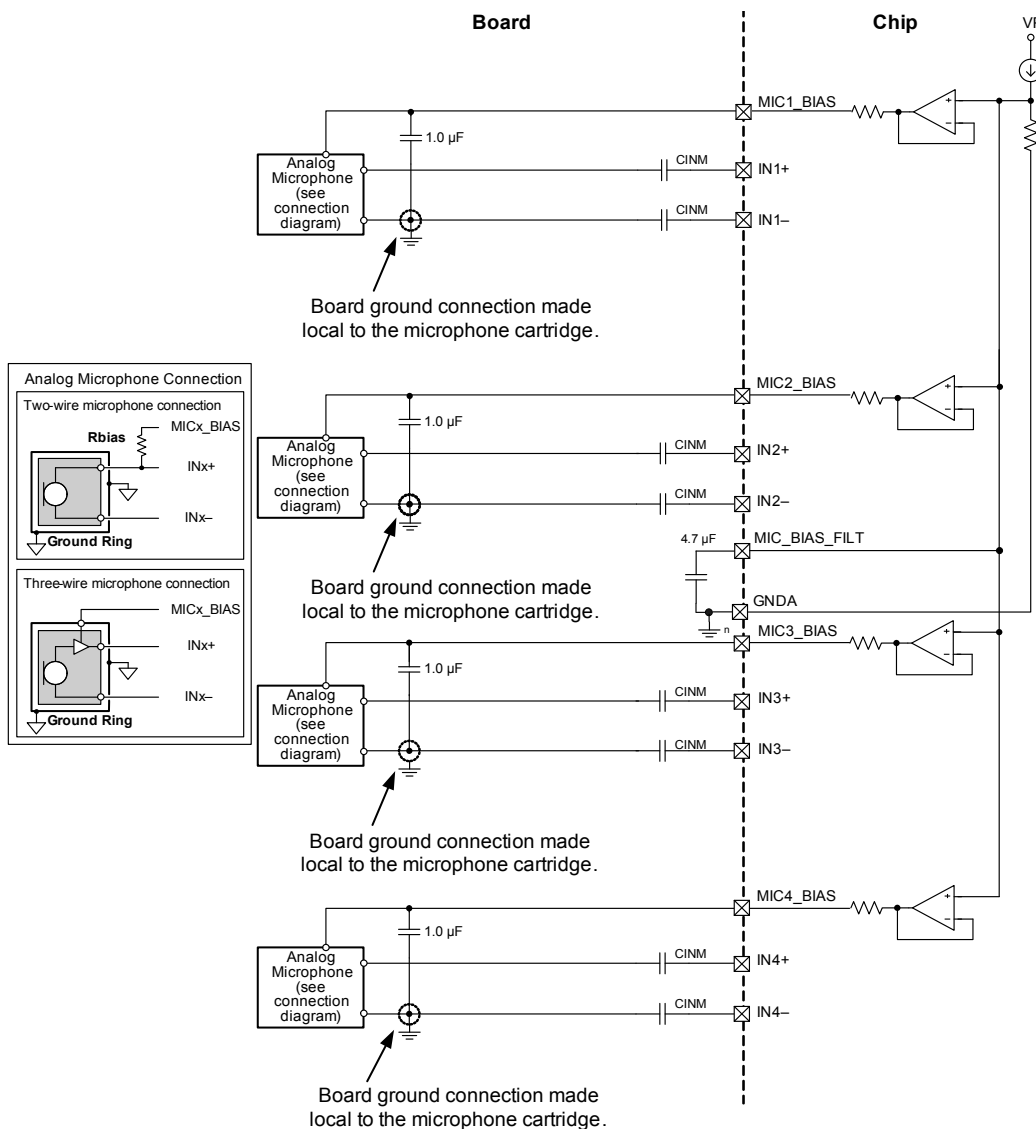

Figure 4-7. Pseudodifferential Mic Input Connections Example

4.4.2 External Coupling Capacitors

The analog inputs are internally biased to the internally generated common-mode voltage (VCM). Input signals must be AC coupled using external capacitors (C_{INM}) with values consistent with the desired HPF design. The analog input resistance may be combined with an external capacitor to achieve the desired cutoff frequency.

Eq. 4-1 provides an example for mic inputs.

$$f_c = \frac{1}{2\pi(1 \text{ M}\Omega)(0.01 \text{ }\mu\text{F})} = 15.9 \text{ Hz}$$

Equation 4-1. External Coupling Capacitors—Mic Inputs

Eq. 4-2 provides an example for line inputs.

$$f_c = \frac{1}{2\pi(50 \text{ k}\Omega)(0.1 \text{ }\mu\text{F})} = 31.83 \text{ Hz}$$

Equation 4-2. External Coupling Capacitors—Line Inputs

4.4.3 Capture-Path Pin Biasing

Capture-path pins are internally biased during normal operation. When connecting analog sources to the CS53L30, the input must be AC-coupled with an external capacitor. These sources may bias the analog inputs:

- Quick-Ref. After an analog input is powered up, the Quick-Ref buffer charges the external capacitor with a low-impedance bias source to minimize startup time.
- Weak VCM. When ADCx is powered up, the weak VCM biases unselected inputs to minimize coupling conditions.
- ADCx_PREAMP. When ADCx is powered up, ADCx_PREAMP biases the selected channel.

See Fig. 4-5 for the location of each bias source.

4.4.4 Soft Ramping (DIGSFT)

DIGSFT (see p. 50) controls whether digital volume updates are applied slowly by stepping through each volume control setting with a delay between steps equal to an integer number of FS_{int} periods. The amount of delay between steps is fixed at 8 FS_{int} periods. The step size is fixed at 0.125 dB.

When enabled, soft ramping is applied to all digital volume changes. Digital volume is affected by the following:

1. Writing directly to the ADC digital volume registers, `ADC1x_VOL` or `ADC2x_VOL` (see p. 54 and p. 56)
2. Enabling or disabling mute by driving a signal to the MUTE pin
3. Muting that is applied automatically by the noise gate
4. Muting that is applied automatically during power up and power down

If digital boost is disabled and the ADC digital volume is set to any value from 0x0C to 0x7F (all equivalent to +12 dB), the soft ramp first steps through the +12-dB settings in the same manner as the remainder of the volume settings. Soft ramp timing calculations must include these additional steps. For example, if the ADC digital volume setting is changed from 0x10 (+12 dB) to 0x00 (0 dB), the first 32 soft ramp steps from 0x10 to 0x0C do not produce any changes in digital volume, while each of the remaining 96 steps from 0x0C (+12 dB) to 0x00 (0 dB) causes a 0.125-dB reduction in digital volume. If digital boost is enabled, the soft ramp does not step through the +12-dB settings.

4.5 Digital Microphone (DMIC) Interface

The digital mic interface can be used to collect pulse-E (PDM) audio data from the integrated ADCs of one or two digital mics. The following sections describe how to use the interface.

4.5.1 DMIC Interface Description

The DMIC interface consists of a serial-data shift clock output (DMICx_SCLK) and a serial data input (DMICx_SD). Fig. 2-2 shows how to connect two digital mics (“Left” and “Right”) to the CS53L30. The clock is fanned out to both digital mics, and both digital mics’ data outputs share a single signal line to the CS53L30. To share a single line, the digital mics tristate their output during one phase of the clock (high or low part of cycle, depending on how they are configured via their \bar{L}/R input). The CS53L30 defaults to mono digital mic input (left channel or rising edge of DMICx_SCLK data only). When **DMIC1_STEREO_ENB** or **DMIC2_STEREO_ENB** (see p. 52) is cleared, then both edges of DMICx_SCLK are used to capture stereo data; Alternating between one digital mic outputting a bit of data and then the other mic outputting a bit of data, the digital mics time domain multiplex on the signal data line. Contention on the data line is avoided by entering the high-impedance tristate faster than removing it.

The DMICx_SD signal can be held low through a weak pulldown (per Section 7.19 and Section 7.20) by its CS53L30 input. When the DMIC interface is active, this pulling is not strong enough to affect the multiplexed data line significantly while it is in tristate between data slots. While the interface is disabled and the data line is not driven, the weak pulling ensures that the CS53L30 input avoids any power-consuming midrail voltage.

4.5.2 DMIC Interface Signaling

Fig. 4-8 shows the signaling on the DMIC interface. Notice how the left channel (A, or DATA1 channel) data from the “Left” mic is sampled on the rising edge of the clock and the right channel (B, or DATA2 channel) data from the “Right” mic is sampled on the falling edge of the clock.

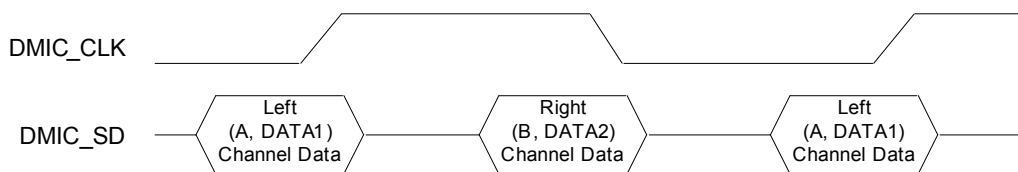

Figure 4-8. Digital Mic Interface Signalling

4.5.3 DMIC Interface Clock Generation

Table 4-1 lists DMIC interface serial clock (DMICx_SCLK) nominal frequencies and their derivation from the internal master clock.

Table 4-1. Digital Mic Interface Clock Generation

Post-MCLK_DIV MCLK Rate (MHz)	MCLK_INT_SCALE	ASP_RATE (kHz) ¹	Divide Ratio	DMICx_SCLK Rate (MHz)	DMICx_SCLK_DIV Programming
5.6448	0	X	2	2.8224	0
			4	1.4112	1
	1	11.025	2	0.7056	0
			4	0.3528	1
		22.050	2	1.4112	0
			4	0.7056	1
		44.1	2	2.8224	0
			4	1.4112	1
6.0000	0	X	2	3.0000	0
			4	1.5000	1
	1	8, 11.025, 12	2	0.7500	0
			4	0.3750	1
		16, 22.050, 24	2	1.5000	0
			4	0.7500	1
		32, 44.1, 48	2	3.0000	0
			4	1.5000	1

Table 4-1. Digital Mic Interface Clock Generation (Cont.)

Post-MCLK_DIV MCLK Rate (MHz)	MCLK_INT_SCALE	ASP_RATE (kHz) ¹	Divide Ratio	DMICx_SCLK Rate (MHz)	DMICx_SCLK_DIV Programming
6.1440	0	X	2	3.0720	0
			4	1.5360	1
	1	8, 11.025, 12	2	0.7680	0
			4	0.3840	1
		16, 22.050, 24	2	1.5360	0
			4	0.7680	1
32, 44.1, 48	2	2	3.0720	0	
		4	1.5360	1	
6.4000	0	X	2	3.2000	0
			4	1.6000	1
	1	8, 11.025, 12	2	0.8000	0
			4	0.4000	1
		16, 22.050, 24	2	1.6000	0
			4	0.8000	1
32, 44.1, 48	2	2	3.2000	0	
		4	1.6000	1	

1. An X indicates that the sample rate setting does not affect DMICx_SCLK rate.

4.6 Serial Ports

The CS53L30 has a highly configurable serial port to communicate audio and voice data to and from other devices in the system such as application processors and Bluetooth™ transceivers.

4.6.1 I/O

The serial port interface consists of four signals:

- ASP_SCLK. Serial data shift clock
- ASP_LRCK/FSYNC. Left/right (I²S) or frame sync clock (TDM)
 - LRCK identifies the start of each serialized data word and locates the left and right channels within the data word when I²S format is used (see [Section 4.6.6](#)).
 - FSYNC identifies the start of each TDM frame.
 - Toggles at external sample rate ($F_{s_{ext}}$).
- ASP_SDOUTx. Serial data outputs

4.6.2 Serial Port Power-Up, Power-Down, and Tristate

The ASP has separate power-down and tristate controls for its output data paths. The serial port power, tristate, and TDM control is done through ASP_3ST, ASP_TDM_PDN, and the respective ASP_SDOUTx_PDN bit. Separating power state controls helps minimize power consumption when the output port is not in use.

- ASP_SDOUTx_PDN. If the SDOUT functionality of a serial port is not required, the SDOUT data path can be powered down by setting ASP_SDOUTx_PDN. The ASP_SDOUTx pin is Hi-Z when ASP_SDOUTx_PDN is set; it does not tristate the serial port clock.
- ASP_3ST. See [Section 4.6.3](#) for details.
- ASP_TDM_PDN. When ASP_TDM_PDN = 1, the ASP serial port is configured to operate in I²S Mode. When ASP_TDM_PDN = 0, ASP is configured to operate in TDM Mode and ASP_SDOUT2 is Hi-Z.

To facilitate clock mastering in TDM Mode, while not sending data, ASP_TDM_PDN and all ASP_TX_ENABLEy bits must be cleared to prevent wasting power to drive the output nets. To save power when no TDM TX slots are used, ASP_SDOUT1 is automatically tristated.

Master/slave operation is controlled only by the $\overline{M/S}$ bit setting and is done irrespective of the setting of the ASP_SDOUTx_PDN, and ASP_3ST bits.

4.6.3 High-Impedance Mode

The serial port may be placed on a clock/data bus that allows multiple masters, without a need for external buffers. The ASP_3ST bit places the internal buffers for the serial port interface signals in a high-impedance state, allowing another device to transmit clocks and data without bus contention. If the CS53L30 serial port is a timing slave, its ASP_SCLK and ASP_LRCK/FSYNC I/Os are always inputs and are thus unaffected by the ASP_3ST control.

In Slave Mode, setting ASP_3ST tristates the ASP_SDOUTx pins. In Master Mode, setting ASP_3ST tristates the ASP_SCLK, ASP_LRCK/FSYNC, and ASP_SDOUTx pins. Before setting an ASP_3ST bit, the associated serial port must be powered down and must not be powered up until the ASP_3ST bit is cleared. Below is the recommended tristate sequence.

Sequence for initiating tristate:

1. Set the ASP_SDOUT1_PDN and ASP_SDOUT2_PDN bits.
2. If the ASP is in TDM Mode, set the ASP_TDM_PDN bit.
3. Set the ASP_3ST bit.

Sequence for removing tristate:

1. Clear the ASP_3ST bit.
2. If TDM Mode is desired, clear the ASP_TDM_PDN bit.
3. Clear the ASP_SDOUT1_PDN and ASP_SDOUT2_PDN bits.

Fig. 4-9 and Fig. 4-10 show serial port interface busing for master and slave timing serial-port use cases.

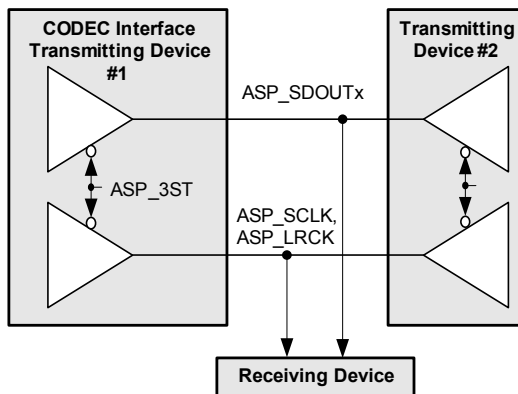

Figure 4-9. Serial Port Busing when Master Timed

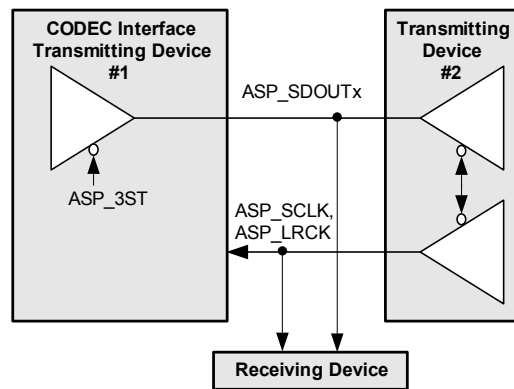

Figure 4-10. Serial Port Busing when Slave Timed

4.6.4 Master and Slave Timing

Serial ports can independently operate as the master of timing or as a slave to another device's timing. When mastering, ASP_SCLK and ASP_LRCK/FSYNC are outputs; when slaved, they are inputs. ASP_M/S determines the Master/Slave Mode.

In Master Mode, ASP_SCLK and ASP_LRCK/FSYNC clock outputs are either derived from the internal MCLK or taken directly from its source, MCLK.

Table 4-2 lists supported interface sample rates ($F_{s_{ext}}$) for each supported MCLK and documents how to program the registers to derive the desired $F_{s_{ext}}$.

4.6.5 Serial-Port Sample Rates

Table 4-2 lists the supported sample rates. Before making changes to any clock setting or frequency, the device must be powered down by setting either the PDN_ULP or PDN_LP bit.

Table 4-2. Supported Master Clocks and Sample Rates

MCLK _{EXT} (MHz)	MCLK _{INT} (MHz)	INTERNAL_FS_RATIO Setting (MCLK _{INT} /FS _{INT})	MCLK_INT_SCALE MCLK _{INT} Scaling	ASP_RATE	FS _{INT} (kHz)	LRCK (FS _{EXT}) (kHz)	MCLK _{EXT} /LRCK Ratio ¹
6.0000	6.0000 (MCLK_DIV = 00)	0	0 (disabled)	0001	48.000	8.000	750
			1 (-4)	0001	12.000	8.000	750
			0 (disabled)	0010	48.000	11.025	80000/147
			1 (-4)	0010	12.000	11.025	80000/147
			X	0011	48.000	11.029 ²	544
			0 (disabled)	0100	48.000	12.000	500
			1 (-4)	0100	12.000	12.000	500
			0 (disabled)	0101	48.000	16.000	375
			1 (-2)	0101	24.000	16.000	375
			0 (disabled)	0110	48.000	22.050	40000/147
			1 (-2)	0110	24.000	22.050	40000/147
			X	0111	48.000	22.059 ²	272
			0 (disabled)	1000	48.000	24.000	250
			1 (-2)	1000	24.000	24.000	250
			X	1001	48.000	32.000	187.5
			X	1010	48.000	44.100	20000/147
X	1011	48.000	44.118 ²	136			
X	1100	48.000	48.000	125			
12.0000	6.0000 (MCLK_DIV = 01)	0	0 (disabled)	0001	48.000	8.000	1500
			1 (-4)	0001	12.000	8.000	1500
			0 (disabled)	0010	48.000	11.025	160000/147
			1 (-4)	0010	12.000	11.025	160000/147
			X	0011	48.000	11.029 ²	1088
			0 (disabled)	0100	48.000	12.000	1000
			1 (-4)	0100	12.000	12.000	1000
			0 (disabled)	0101	48.000	16.000	750
			1 (-2)	0101	24.000	16.000	750
			0 (disabled)	0110	48.000	22.050	80000/147
			1 (-2)	0110	24.000	22.050	80000/147
			X	0111	48.000	22.059 ²	544
			0 (disabled)	1000	48.000	24.000	500
			1 (-2)	1000	24.000	24.000	500
			X	1001	48.000	32.000	375
			X	1010	48.000	44.100	40000/147
X	1011	48.000	44.118 ²	272			
X	1100	48.000	48.000	250			
5.6448	5.6448 (MCLK_DIV = 00)	1	0 (disabled)	0100	44.100	11.025	512
			1 (-4)	0100	11.025	11.025	512
			0 (disabled)	1000	44.100	22.050	256
			1 (-2)	1000	22.050	22.050	256
			X	1100	44.100	44.100	128
11.2896	5.6448 (MCLK_DIV = 01)	1	0 (disabled)	0100	44.100	11.025	1024
			1 (-4)	0100	11.025	11.025	1024
			0 (disabled)	1000	44.100	22.050	512
			1 (-2)	1000	22.050	22.050	512
			X	1100	44.100	44.100	256

Table 4-2. Supported Master Clocks and Sample Rates (Cont.)

MCLK _{EXT} (MHz)	MCLK _{INT} (MHz)	INTERNAL_FS_RATIO Setting (MCLK _{INT} /FS _{INT})	MCLK_INT_SCALE MCLK _{INT} Scaling	ASP_RATE	FS _{INT} (kHz)	LRCK (FS _{EXT}) (kHz)	MCLK _{EXT} /LRCK Ratio ¹
6.1440	6.1440 (MCLK_DIV = 00)	1	0 (disabled)	0001	48.000	8.000	768
			1 (-4)	0001	12.000	8.000	768
			0 (disabled)	0010	48.000	11.025	81920/147
			1 (-4)	0010	12.000	11.025	81920/147
			0 (disabled)	0100	48.000	12.000	512
			1 (-4)	0100	12.000	12.000	512
			0 (disabled)	0101	48.000	16.000	384
			1 (-2)	0101	24.000	16.000	384
			0 (disabled)	0110	48.000	22.050	40960/147
			1 (-2)	0110	24.000	22.050	40960/147
			0 (disabled)	1000	48.000	24.000	256
			1 (-2)	1000	24.000	24.000	256
			X	1001	48.000	32.000	192
			X	1010	48.000	44.100	20480/147
X	1100	48.000	48.000	128			
12.2880	6.1440 (MCLK_DIV = 01)	1	0 (disabled)	0001	48.000	8.000	1536
			1 (-4)	0001	12.000	8.000	1536
			0 (disabled)	0010	48.000	11.025	163840/147
			1 (-4)	0010	12.000	11.025	163840/147
			0 (disabled)	0100	48.000	12.000	1024
			1 (-4)	0100	12.000	12.000	1024
			0 (disabled)	0101	48.000	16.000	768
			1 (-2)	0101	24.000	16.000	768
			0 (disabled)	0110	48.000	22.050	81920/147
			1 (-2)	0110	24.000	22.050	81920/147
			0 (disabled)	1000	48.000	24.000	512
			1 (-2)	1000	24.000	24.000	512
			X	1001	48.000	32.000	384
			X	1010	48.000	44.100	40960/147
X	1100	48.000	48.000	256			
19.2000	6.4000 (MCLK_DIV = 10)	1	0 (disabled)	0001	50.000	8.000	2400
			1 (-4)	0001	12.500	8.000	2400
			0 (disabled)	0010	50.000	11.025	256000/147
			1 (-4)	0010	12.500	11.025	256000/147
			0 (disabled)	0100	50.000	12.000	1600
			1 (-4)	0100	12.500	12.000	1600
			0 (disabled)	0101	50.000	16.000	1200
			1 (-2)	0101	25.000	16.000	1200
			0 (disabled)	0110	50.000	22.050	128000/147
			1 (-2)	0110	25.000	22.050	128000/147
			0 (disabled)	1000	50.000	24.000	800
			1 (-2)	1000	25.000	24.000	800
			X	1001	50.000	32.000	600
			X	1010	50.000	44.100	64000/147
X	1100	50.000	48.000	400			

1. The internal synchronous SRC guarantees the MCLK_{EXT}/LRCK ratio when the CS53L30 is a PCM bus master. If the CS53L30 is a PCM slave, the PCM master must provide the exact MCLK/LRCK ratio.

2. Supported only if CS53L30 is a PCM bus slave.

4.6.6 I²S Format

I²S format offers the following:

- Up to 24 bits/sample of stereo data can be transferred (see [Section 4.6.6.1](#)).
- Master or slave timing may be selected.
- LRCK (i.e., ASP_LRCK/FSYNC) identifies the start of a new sample word and the active stereo channel (A or B).
- Data is clocked out of the ASP_SDO_{UTx} output using the falling edge of SCLK (i.e., ASP_SCLK).
- Bit order is MSB to LSB.

[Fig. 4-11](#) shows the signaling for I²S format.

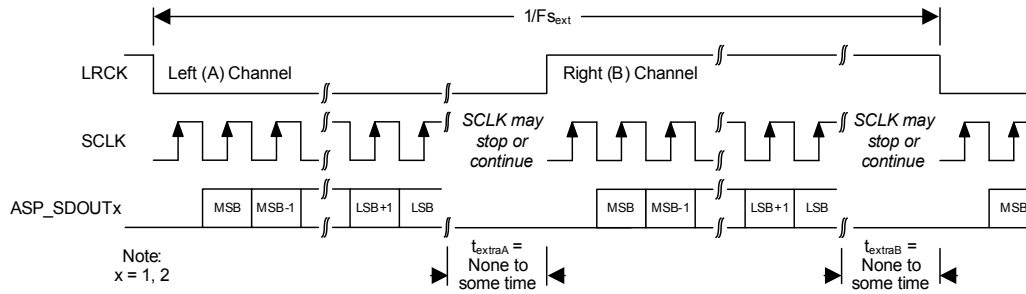
Figure 4-11. I²S Format

4.6.6.1 I²S Format Bit Depths

I²S interface data word length (see [Section 4.6.6](#)) is ambiguous. Fortunately, the I²S format is also left justified, with MSB-to-LSB bit ordering, negating the need for a word-length control register. If at least 24 serial clocks are present per channel sample, the CS53L30 always sends 24-bit data. If fewer clocks are present, it outputs as many bits as there are clocks. If more are present, it transmits zeros for any clock cycles after the 24th bit. The receiving device is expected to load data in MSB-to-LSB order until its word depth is reached, at which point it must discard any remaining LSBs.

4.7 TDM Mode

The ASP can operate in TDM Mode, which includes the following features:

- Defeatable SDOUT driver for sharing the TDM bus between multiple devices
- Flexible data structuring via control port registers
- Clock master and slave modes

4.7.1 Bus Format and Clocking

The serviceable TDM data stream is defined as 48 8-bit slots, as clocked by SCLK (i.e., ASP_SCLK). Unlike operating the port in I²S Mode, where SCLK is scaled to always be approximately 64 bits per LRCK toggle, SCLK is not required to be scaled when the device is operating as a clock slave and is not scaled when the device is operating as a clock master. For example, if a 6.400-MHz clock is used for SCLK, a 16-kHz sample rate would result in 48 available slots or 16 available 24-bit (3-slot) flows with 16 unused SCLK cycles per 400 SCLK cycles (16-kHz frame). If the sample rate were changed to 8 kHz, the bus would support 48 possible 8-bit slots, but would result in 416 unused SCLK cycles per 800 SCLK cycles with = 6.400 MHz.

TDM frames are bounded by the FSYNC signal (i.e., ASP_LRCK/FSYNC). The placement of the first bit applied to SDOUT (i.e., ASP_SDOUT1) in a given TDM frame is programmable using the SHIFT_LEFT bit. By default, the first bit of the TDM frame is driven on the second rising edge of SCLK following the rising edge of FSYNC. The first bit of the TDM frame can be moved up a half SCLK cycle earlier by setting the SHIFT_LEFT bit. SHIFT_LEFT and ASP_SCLK_INV can be used in conjunction to achieve a frame start (i.e., first data bit driven out) on the first rising edge of SCLK as shown in [Fig. 4-17](#). The high time of FSYNC is also programmable by programming LRCK_TPWH[10:3] (see [Section 7.15](#)), LRCK_TPWH[2:0], and LRCK_50_NPW (see [Section 7.16](#)).

[Fig. 4-12](#)–[Fig. 4-15](#) show the four possible TDM formats achievable using the ASP_SCLK_INV and SHIFT_LEFT bits. The number of unused SCLK cycles in each case is zero. [Fig. 4-16](#) shows an example of the resulting TDM frame structure when there are unused SCLK cycles in the frame.

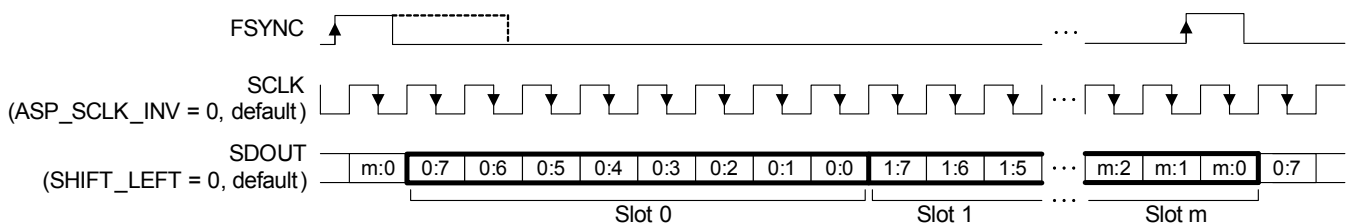
Figure 4-12. TDM Format—ASP_SCLK_INV = 0, SHIFT_LEFT = 0

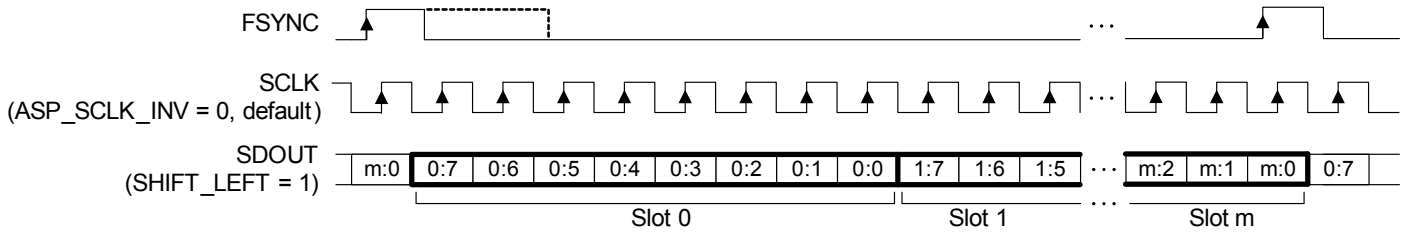
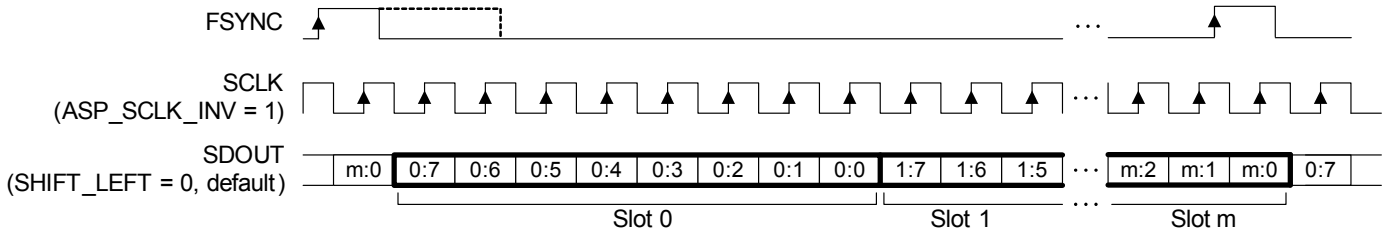
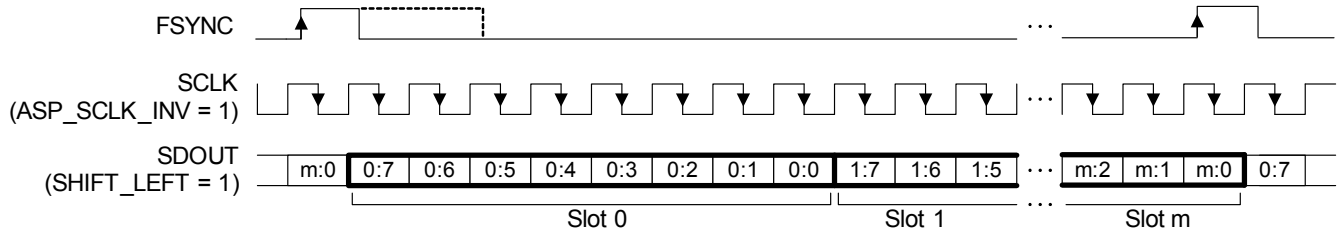
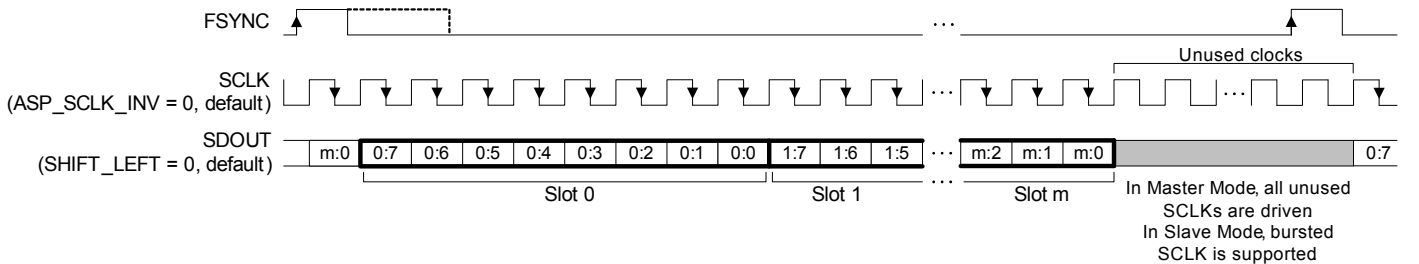
Figure 4-13. TDM Format—ASP_SCLK_INV = 0, SHIFT_LEFT = 1

Figure 4-14. TDM Format—SCLK_INV = 1, SHIFT_LEFT = 0

Figure 4-15. TDM Format—SCLK_INV = 1, SHIFT_LEFT = 1

Figure 4-16. TDM Format—Unused SCLK Cycles

In TDM Master Mode, SCLK is a buffered version of MCLK and is not scaled to FS_{ext} as it is in I²S Mode. Because of this, and because the number of available bits on a given bus is defined by the ratio of SCLK to sample rate ($SCLK/f_{FSYNC}$), the TDM bus use can vary. As Table 4-3 shows, applying the $SCLK/f_{FSYNC}$ relationship to the supported clocks and sample rates of the device results in different numbers of available slots as well as different numbers of unused bits.

Table 4-3. Slot Count and Resulting Unused Clock Cycles for Supported SCLK and Sample Rates

SCLK Frequency [MHz]	FSYNC Sample Rate [kHz]	Number of Available Slots	Resulting Number of Unused SCLK Cycles
5.6448	11.025	48	128
	22.050	32	0
	44.100	16	0
11.2896	11.025	48	640
	22.050	48	128
	44.100	32	0

Table 4-3. Slot Count and Resulting Unused Clock Cycles for Supported SCLK and Sample Rates (Cont.)

SCLK Frequency [MHz]	FSYNC Sample Rate [kHz]	Number of Available Slots	Resulting Number of Unused SCLK Cycles
6.0000	8.000	48	366
	11.025	48	160
	12.000	48	116
	16.000	46	7
	22.050	34	0
	24.000	31	2
	32.000	23	4
	44.100	17	0
12.0000	48.000	15	5
	8.000	48	1116
	11.025	48	704
	12.000	48	616
	16.000	48	366
	22.050	48	160
	24.000	48	116
	32.000	46	8
6.1440	44.100	34	0
	48.000	31	2
	8.000	48	384
	11.025	48	173
	12.000	48	128
	16.000	48	0
	22.050	34	6
	24.000	32	0
12.2880	32.000	24	0
	44.100	17	3
	48.000	16	0
	8.000	48	1152
	11.025	48	731
	12.000	48	640
	16.000	48	384
	22.050	48	173
6.4000 ¹	24.000	48	128
	32.000	48	0
	44.100	34	6
	48.000	32	0
	8.000	48	416
	11.025	48	196
	12.000	48	149
	16.000	48	16
	22.050	36	2
	24.000	33	2
	32.000	25	0
	44.100	18	1
	48.000	16	5

1. 6.4 MHz is the highest SCLK frequency allowed if MCLK_19MHZ_EN is set.

4.7.2 Bursted SCLK

After all the data is sent on the TDM bus, it is not necessary to continue to toggle SCLK for the remaining unused slots. Not toggling SCLK after all data is sent and received saves power, by avoiding driving the output and clock capacitances unnecessarily. When the device is operating as a timing slave, bursted SCLK is naturally supported, since data is clocked out only when SCLK toggles. When the device is operating as a timing master, bursted SCLK is not supported.

4.7.3 Transmitting Data

Fig. 4-17 shows the TDM transmit subblock.

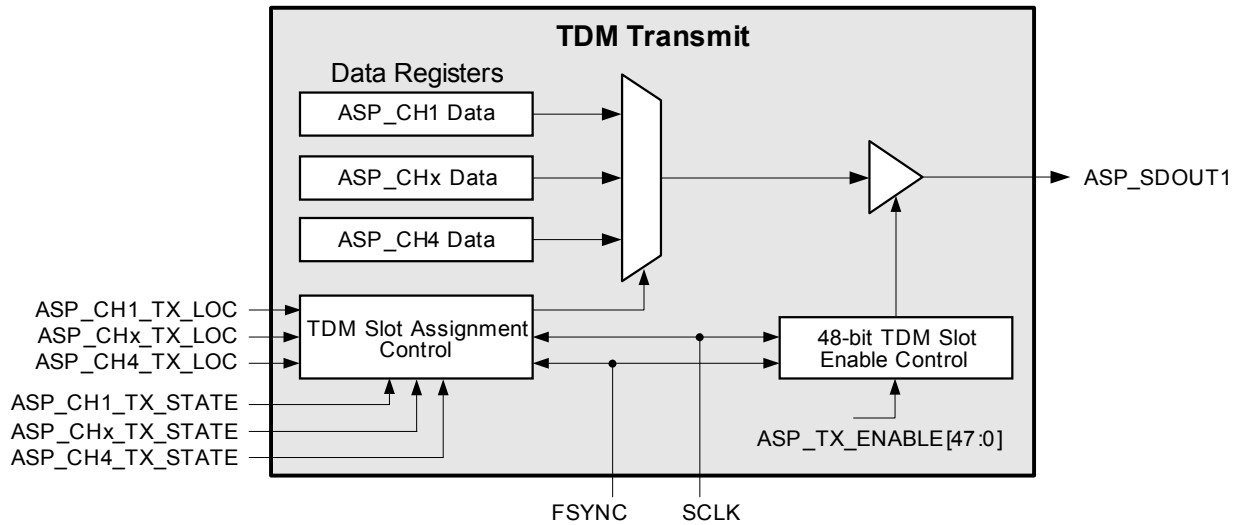

Figure 4-17. TDM Transmit Subblock Diagram

4.7.3.1 Transmit Data Structuring

Data registers are assigned to slots using the `ASP_CHx_LOC`, `ASP_CHx_TX_STATE`, and the `ASP_TX_ENABLE` controls. The `ASP_CHx_TX_LOC` control (“x” is the channel number) determines which of the available 48 slots the data set should be loaded into, MSB first. If an internal data register is not to be transmitted outside of the part, clear `ASP_CHx_TX_STATE`. `ASP_TX_ENABLE` determines which of the loaded slots are transmitted on the `ASP_SDOOUT1` pin.

The SDOOUT driver enters a Hi-Z state for disabled slots. An important implication of disabling slots is that if a disabled slot lies between two enabled slots, the SDOOUT driver enters a Hi-Z state during the disabled slot segment, but the data for both enabled slots is transmitted. For example, if a 24-bit data set is assigned to Slots 0–2, but the `TX_ENABLE1` bit is cleared, the highest 8 bits of data are sent in Slot 0, the SDOOUT driver enters a Hi-Z state during Slot 1 (the middle 8 bits of data are lost), and the lowest 8 bits of data are sent in Slot 2.

If the start slot location of a data set overlaps one or more slots of a previous data set, the new data set has higher priority (e.g., if the Channel 1 data set starts in Slot 0 and the Channel 2 data set starts in Slot 1, Slot 1 contains Channel 2 data). If two or more data sets are allocated to use the same slot start location, the lowest numbered channel has the highest priority (e.g., the Channel 2 data set has higher priority than the Channel 3 and Channel 4 data sets).

4.7.3.2 Transmit Data Register Bit Depths

The bit depths of the internal data registers are 24 bits. The configurability of the CS53L30’s TDM data structure makes it possible to allocate the data register to a different bit depth on the TDM bus than that of its respective internal data register.

If a data set is allocated fewer bits than its internal data register bit depth, the data is truncated. The transmission of the slots that would have held the excess data can be disabled.

If the data set is allocated a bit depth larger than the bit depth of its internal data registers, zeros are transmitted in the lower LSBs after all the data in the data register has been transmitted.

4.7.3.3 TDM Bus Sharing among Multiple Devices

Bus sharing is supported for device transmit. Sharing the bus among multiple devices that are attempting to transmit data simultaneously is not inherent to the TDM architecture. Since the devices may likely be attempting to drive different data from one another, this presents an opportunity for bus contention.

To prevent bus contention, the data from internal data registers must be allocated to different slots within the TDM stream using each device’s `ASP_CHx_TX_LOC` controls.

To maximize bus usage, the device supports hand-off between devices in a half clock cycle, which means no clock cycles have to be sacrificed during the hand-off between two devices. This behavior is shown in [Table 3-12](#). If `SHIFT_LEFT` (see [p. 45](#)) is set, the hand-off between two devices has no margin and brief bus contention may occur.

As shown in [Table 3-12](#), the transmission of the last LSB before a disabled slot transitions to Hi-Z earlier than a normal transition to allow more time for the data being driven by the succeeding device to become stable on the bus before being clocked in by the receiver. This minimizes the risk of bus contention and ensures that any data loss affects only the LSB of a given data set, not the MSB. Bus sharing after the 48-slot window is not supported and `SDOUT` will be driven for up to 16 `SCLKs` following the 48th slot. After the 16th `SCLK`, `SDOUT` is driven low for the remainder of the frame. The expected behavior follows:

- As long as `SCLK` is toggling, data transfers of up to 3 bytes can be initiated from any of the 48 slots, including the last two (Slots 46–47).
If a transfer is configured from either of the last two slots (Slot 46 or 47), `SDOUT` drives all 24 bits of specified data, after which `SDOUT` is driven low.
- If Slot 47 is not enabled, `SDOUT` is set to Hi-Z and remains at Hi-Z until the end of the frame.

4.8 Synchronous Sample-Rate Converter (SRC)

The CS53L30 includes dual decimation-mode synchronous stereo SRC to bridge potentially different sample rates in the system. Multirate digital signal-processing techniques are used to conceptually up-sample the incoming data to a very high rate and then down-sample to the outgoing rate. Internal filtering is designed so that a full input audio bandwidth of 20 kHz is preserved if the output sample rate is greater than or equal to 44.1 kHz. Any jitter in the incoming signal has little effect on the dynamic performance of the rate converter and has no influence on the output clock.

The `MCLK` to `LRCK` ratios defined in [Table 4-2](#) must be followed to achieve the sample rates in either Master or Slave Mode. The coefficients of a linear time varying filter are predetermined to produce the output sample rates in [Table 4-2](#) if the `MCLK` to `LRCK` ratios are used.

The gain from `INx` to `SDOUT` through the SRC is dependent on output sample rate (i.e., `LRCK` frequency) and `MCLK` frequency. [Table 4-4](#) shows the gain with a 1-kHz full scale input over the supported sample rates and `MCLK` frequencies.

Table 4-4. Synchronous SRC Gain Versus Sample Rate

MCLK_{ext} (kHz)	LRCK (kHz)	Gain (dB) ¹
5.6448, 11.2896	11.025	-0.173
	22.050	-0.170
	44.100	-0.168
6.0000, 6.1440, 12.0000, 12.2880	8.000	-0.313
	11.025	-0.291
	12.000	-0.172
	16.000	-0.307
	22.050	-0.288
	24.000	-0.169
	32.000	-0.305
	44.100	-0.287
	48.000	-0.167
19.2000	8.000	-0.383
	11.025	-0.241
	12.000	-0.231
	16.000	-0.376
	22.050	-0.236
	24.000	-0.231
	32.000	-0.374
	44.100	-0.238
48.000	-0.231	

1. Gain with a 1-kHz, full scale input sine wave, 0-dB gain preamp setting, and 0-dB PGA gain setting, `ADCx_NOTCH_DIS` = 1, `ADCx_HPF_EN` = 0.

4.9 Multichip Synchronization Protocol

Due to the multidrop capability of the CS53L30 TDM bus, it is conceivable to employ up to four CS53L30 chips to allow up to 16 channels of audio capture. Extra care and sequencing steps have to be taken to ensure that the multichip configuration meets the channel-to-channel phase matching specification across chips when using multiple CS53L30 chips in a system. Below is the recommended sequence to minimize phase mismatch across channels/chips. Any deviation from this procedure causes deterministic, as well as nondeterministic, phase differences across chips and the channel-to-channel phase mismatch specifications in [Table 3-5](#) cannot be guaranteed. The SYNC pins of all devices must be connected directly at the board level.

Synchronization sequence:

1. Release $\overline{\text{RESET}}$ to all devices.
2. Configure the control port of all devices.
3. Clear PDN_ULP and/or PDN_LP in all devices.
4. Set the SYNC_EN bit of one of the devices only (the “initiator” device).
5. After successful synchronization, the SYNC_DONE status bit (see [p. 57](#)) is set on all connected CS53L30s that have received the SYNC protocol (including the initiator device).

Alternate synchronization sequence:

1. Release $\overline{\text{RESET}}$ to all devices.
2. Configure the control port of all devices.
3. Set the SYNC_EN bit of one of the devices only (the “initiator” device).
4. Clear PDN_ULP and/or PDN_LP in all devices except the initiator device.
5. Clear PDN_ULP and/or PDN_LP in the initiator device.
6. After successful synchronization, the SYNC_DONE status bit (see [p. 57](#)) is set on all connected CS53L30s that have received the SYNC protocol (including the initiator device).

4.10 Input Path Source Selection and Powering

[Table 4-5](#) describes how the CH_TYPE, ADCxy_PDN, and DMICx_PDN controls affect the CS53L30. The DMICx_PDN control only affects the state of the digital mic interface clock.

Table 4-5. ADCx/DMICx Input Path Source Select and Digital Power States (Where x = 1 or 2)

Control Register States				Channel A Input Path		Channel B Input Path		DMICx_SCLK
CH_TYPE	DMICx_PDN	ADCxA_PDN	ADCxB_PDN	Data Source	Power State	Data Source	Power State	
1	0	0	0	DMICx	On	DMICx	On	On
1	0	0	1	DMICx	On	—	Off	On
1	0	1	0	—	Off	DMICx	On	On
1	0	1	1	—	Off	—	Off	On
0	1	0	0	ADCxA	On	ADCxB	On	Off
0	1	0	1	ADCxA	On	—	Off	Off
0	1	1	0	—	Off	ADCxB	On	Off
0	1	1	1	—	Off	—	Off	Off

4.11 Thermal Overload Notification

The CS53L30 can be configured to notify the system processor that its die temperature is too high. The processor can use this notification to prevent damage to the CS53L30 and to other devices in the system. When notified, the processor should react by powering down CS53L30 (and/or other devices in the system) partially or entirely, depending on the extent to which the CS53L30’s power dissipation is the cause of its excessive die temperature. The CS53L30 is a low-power device and any thermal overload is likely coming from elsewhere in the system.

To use thermal overload notification, do the following:

1. Enable the thermal-sense circuitry by programming `THMS_PDN` (see p. 48).
2. Set `M_THMS_TRIP` (see p. 57) if an interrupt is desired when `THMS_TRIP` toggles from 0 to 1.
3. Monitor (read after interrupt [QFN only] or poll) the thermal overload interrupt status bit and respond accordingly.

Except for the associated status bit, the operation of the CS53L30 is not affected by the thermal overload notification.

4.12 MUTE Pin

If MUTE is asserted, all four audio channels are muted. In addition, other circuits can be powered down; for example, power down all ADCs and MIC_BIAS outputs or individual ADC channels or MIC_BIAS outputs by programming the MUTE pin control registers (Section 7.17 and Section 7.18 list programming options).

If `DIGSFT` (see p. 50) is set when the MUTE pin is asserted or deasserted, the corresponding volume ramp occurs before the power-state change.

4.13 Power-Up and Power-Down Control

The CS53L30 offers the following for managing power:

- The `RESET` pin
- The `PDN_ULP` bit (see p. 47)
- The `PDN_LP` bit (see p. 47)
- Individual `x_PDN` bits

In addition, the MUTE pin can also be programmed to affect any or all of the PDNs. When `RESET` is asserted, all blocks are powered down and reset to their default values. (See Table 3-14 for minimum `RESET` pulse width.) In power down (`PDN_ULP = 1` or `PDN_LP = 1`), all blocks except the I²C control port are powered down. `PDN_ULP` is used for ultralow-power operation as it powers down the internal bandgap, VREF, VCM, weak VCM, as well as the ADCs, state machines, etc. `PDN_LP` is used for low-power operation and only powers down the ADCs, state machines, etc. `PDN_ULP` and `PDN_LP` can be used to control the sequence of what is powered in the CS53L30. When both `PDN_ULP` and `PDN_LP` are cleared, all blocks are powered up depending on the individual `x_PDN` bits. If both `PDN_ULP` and `PDN_LP` are cleared simultaneously, the bandgap, VREF, and VCM circuits are not available for approximately 20 ms. To effect a more deterministic power-up of the ADCs, internal dividers, state machines, etc., the following sequence is recommended:

1. Set both `PDN_ULP` and `PDN_LP`.
2. Release `PDN_ULP`.
3. Wait 50 ms before releasing `PDN_LP`.

4.14 I²C Control Port

The control port is used to access the registers allowing the device to be configured for the desired operational modes and formats. The operation of the control port may be completely asynchronous with respect to the audio sample rates. However, to avoid potential interference problems, the control port pins should remain static if no operation is required.

SDA is a bidirectional data line. Data is clocked into and out of the CS53L30 by the clock, SCL. The signal timings for read and write cycles are shown in Fig. 4-18–Fig. 4-20. A Start condition is defined as a falling transition of SDA while the clock is high. A Stop condition is defined as a rising transition of SDA while the clock is high. All other transitions of SDA occur while the clock is low.

The first byte sent to the CS53L30 after a Start condition consists of a 7-bit chip address field and a `R/W` bit (high for a read, low for a write) in the LSB. To communicate with the CS53L30, the chip address field is dependent upon the state of AD0 and AD1 after `RESET` has been deasserted and should match 1001 000 if AD1,0 = 00, 1001 001 if AD1,0 = 01, 1001 010 if AD1,0 = 10, and 1001 011 if AD1,0 = 11.

AD0 and AD1 are the logic state of the ASP_SDOOUT2/AD0 and DMIC2_SCLK/AD1 pins, which are pulled to the supply or ground. These pins configure the I²C device address upon a device power up, after **RESET** is deasserted. These pins have internal pull-down resistors, allowing for the default I²C address with no external components. If an I²C address other than the default is desired, then external resistor termination to VA is required. The minimum resistor value allowed is 10 kΩ. The time constant resulting from the pull-up or pull-down resistor and the total net capacitance should be considered when determining the time required for the pin voltage to settle before **RESET** is deasserted. See [Table 3-14](#) for specifications on internal pull-down resistance and V_{IH} and V_{IL} voltage.

The next byte is the memory address pointer (MAP); the 7 LSBs of the MAP byte select the address of the register to be read or written to next. The MSB of the MAP byte, INCR, selects whether autoincrementing is to be used (INCR = 1), allowing successive reads or writes of consecutive registers.

Each byte is separated by an acknowledge bit. The ACK bit is output from the CS53L30 after each input byte is read and is input to the CS53L30 from the microcontroller after each transmitted byte.

If the operation is a write, the bytes following the MAP byte are written to the CS53L30 register address indicated by the sum of the last-received MAP and the number of times the MAP has automatically incremented since the MAP was last received. [Fig. 4-18](#) shows a write pattern with autoincrementing.

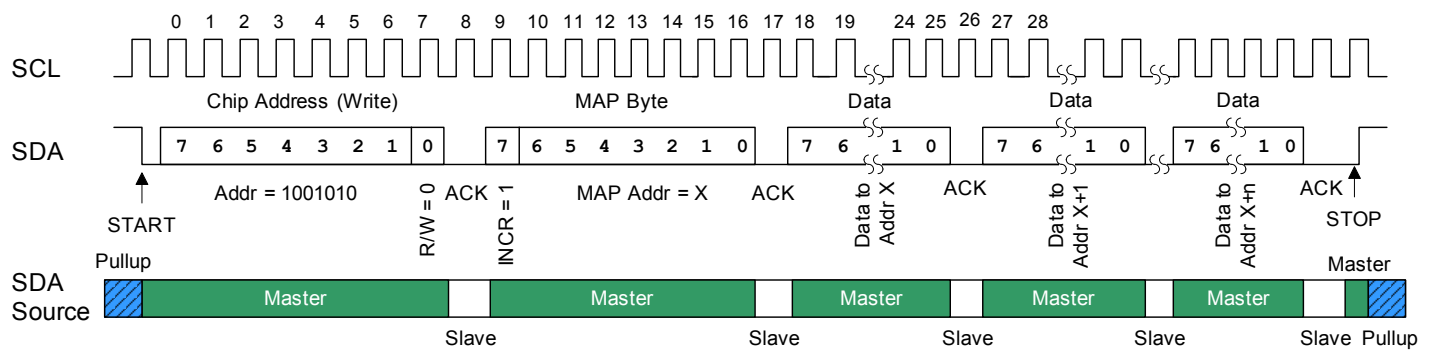

Figure 4-18. Control Port Timing, I²C Writes with Autoincrement

If the operation is a read, the contents of the register indicated by the sum of the last-received MAP and the number of times the MAP has automatically incremented since it was last received, are output in the next byte. [Fig. 4-19](#) shows a read pattern following the write pattern in [Fig. 4-18](#). Notice how read addresses are based on the MAP byte from [Fig. 4-18](#).

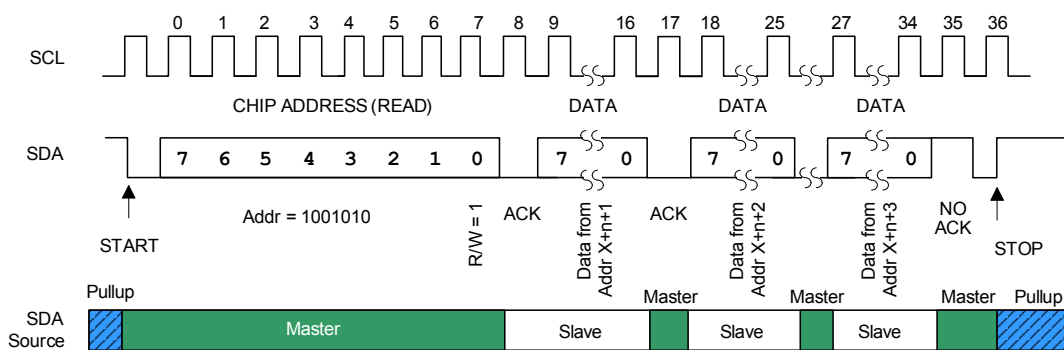

Figure 4-19. Control Port Timing, I²C Reads with Autoincrement

If a read address not based on the last received MAP address is desired, an aborted write operation can be used as a preamble that sets the desired read address. This preamble technique is shown in [Fig. 4-20](#): A write operation is aborted (after the acknowledge for the MAP byte) by sending a stop condition.

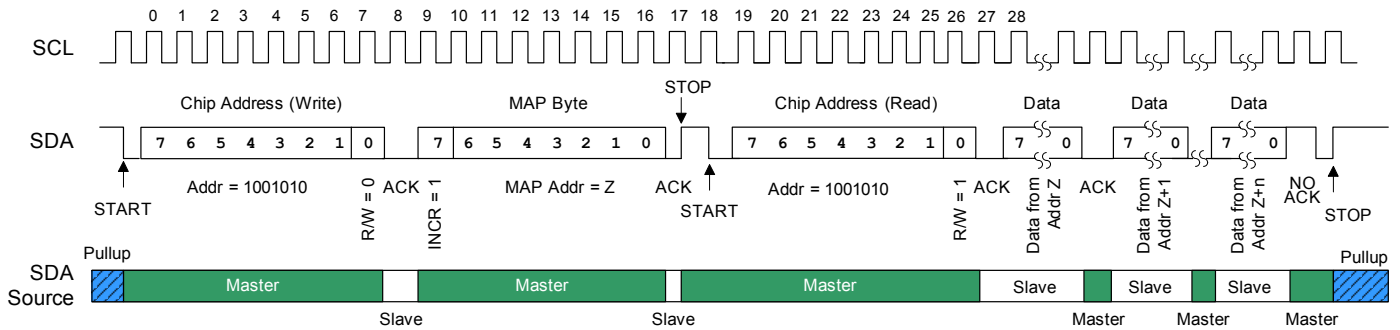

Figure 4-20. Control Port Timing, I²C Reads with Preamble and Autoincrement

The following pseudocode illustrates an aborted write operation followed by a single read operation. For multiple read operations, autoincrement would be set on (as is shown in Fig. 4-20).

```

Send start condition.
Send 10010100 (chip address and write operation).
Receive acknowledge bit.
Send MAP byte, autoincrement off.
Receive acknowledge bit.
Send stop condition, aborting write.
Send start condition.
Send 10010101 (chip address and read operation).
Receive acknowledge bit.
Receive byte, contents of selected register.
Send acknowledge bit.
Send stop condition.
    
```

Note: The device interrupt status register (at address 0x36) and the register that immediately precedes it (the device interrupt mask register at address 0x35) must only be read individually and not as a part of an autoincremented control-port read. An autoincremented read of either register may clear the contents of the interrupt status register and return invalid interrupt status data. If an unmasked interrupt condition had caused INT to be asserted, INT may be unintentionally deasserted.

Therefore, to avoid affecting interrupt status register contents, the autoincrement read must not include registers at addresses 0x35 and 0x36; these registers must only be read individually.

4.15 QFN Thermal Pad

The underside of the compact QFN package reveals a large metal pad that serves as a thermal relief to provide for maximum heat dissipation. Internal to the package, all grounds are connected to the thermal pad. This pad must mate with an equally dimensioned copper pad on the PCB and must be electrically connected to ground. If necessary for thermal reasons, a series of vias can be used to connect this copper pad to one or more larger ground planes on other PCB layers.

5 Systems Applications

This section describes the following system applications and considerations:

- Octal mic array application ([Section 5.1](#))
- Power-up sequence ([Section 5.2](#))
- Quick-mute sequencing ([Section 5.3](#))
- Capture-path input considerations ([Section 5.3](#))
- MCLK jitter ([Section 5.5](#))
- Frequency response considerations ([Section 5.6](#)).

5.1 Octal Microphone Array to the Audio Serial Port

Fig. 5-1 shows connections for an eight-channel mic array to serial port schematic configuration.

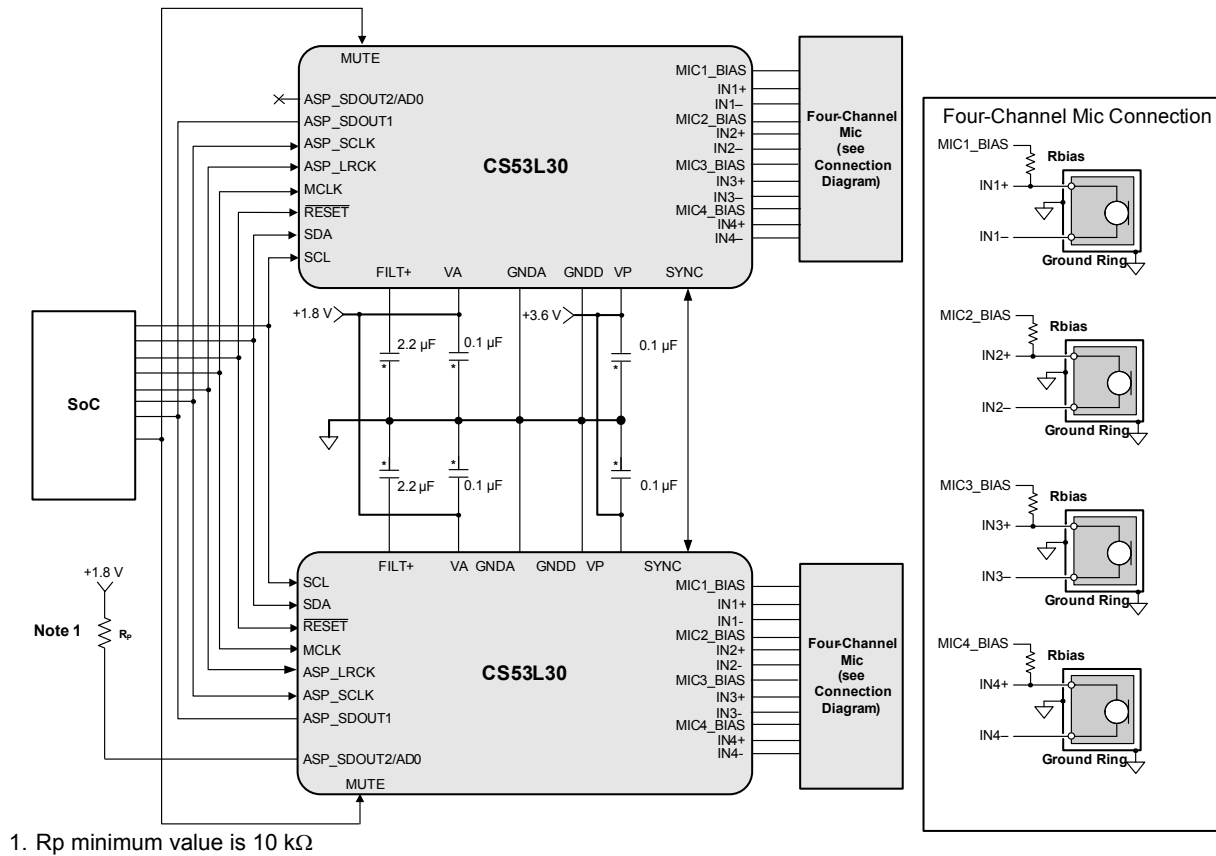

Figure 5-1. Octal Microphone Array Dual-CS53L30 Schematic

5.1.1 Phase-Calibration Considerations

The CS53L30 can be used in a multidevice application like the one shown in Fig. 5-1. In such a system, there are four classifications of phase mismatch and they originate from various sources. Each class listed in Table 5-1 may contribute to the overall phase error.

Table 5-1. Phase Mismatch Classifications

Type	Classification	Source
1	Deterministic, time invariant	<ul style="list-style-type: none"> Manufacturing tolerances of chosen components Board temperature gradients Board layout and route
2	Deterministic, time varying	<ul style="list-style-type: none"> Power-up sequencing LRCK chip-to-chip skew
3	Nondeterministic, time varying	<ul style="list-style-type: none"> MCLK, LRCK/FSYNC jitter SRC initial conditions
4	Nondeterministic, time invariant	<ul style="list-style-type: none"> ADC sample aperture

In this description, it is assumed that board components including the CS53L30 devices have been chosen or fixed. The system board has been designed, placed, and routed, and thus all systematic phase mismatch due to the fabrication or manufacturing of the chosen components is called “deterministic.” These systematic elements are time invariant for the given set of components.

Example 5-1. Power-Up Sequence (Cont.)

STEP	TASK	REGISTER/BIT FIELDS	VALUE	DESCRIPTION
6.4	Configure TDM channels.	ASP TDM TX Control 1–4, Address 0x0E–0x11		
		ASP TDM TX Control 1, Address 0x0E	0x00	
		ASP_CH1_STATE†	0	Channel 1 data is available.
		Reserved	0	—
		ASP_CH1_TX_LOC[5:0]†	00 0000	Channel 1 begins at Slot 0.
		ASP TDM TX Control 2, Address 0x0F	0x03	
		ASP_CH2_STATE†	0	Channel 2 data is available.
		Reserved	0	—
		ASP_CH2_TX_LOC[5:0]†	00 0011	Channel 2 begins at Slot 3.
		ASP TDM TX Control 3, Address 0x10	0x06	
		ASP_CH3_STATE†	0	Channel 3 data is available.
		Reserved	0	—
ASP_CH3_TX_LOC[5:0]†	00 0110	Channel 3 begins at Slot 6.		
6.5	Enable TDM slots.	ASP TDM TX Enable 1–6, Address 0x12–0x17		
		ASP TDM TX Enable 1, Address 0x16	0x0F	
		ASP_TX_ENABLE1[7:0]†	0000 1111	Slots 8–11 are enabled.
		ASP TDM TX Enable 2, Address 0x17	0xFF	
		ASP_TX_ENABLE1[7:0]†	1111 1111	Slots 0–7 are enabled.
		7	Write the following registers to configure MUTE pin functionality.	
STEP TASK	REGISTER/BIT FIELDS	VALUE	DESCRIPTION	
7.1	Configure MUTE pin power down controls.	MUTE Pin Control 1, Address 0x1F†	0x00	Default values (power down controls are not affected by MUTE pin)
7.2	Configure MUTE pin polarity and power down controls.	MUTE Pin Control 2, Address 0x20†	0x80	Default values (MUTE pin is active high, power down controls are not affected by MUTE pin)
8	Write the following registers to configure the mic bias outputs.	REGISTER/BIT FIELDS	VALUE	DESCRIPTION
		Mic Bias Control, Address 0x0A	0x06	
		MIC4_BIAS_PDN–MIC1_BIAS_PDN†	0000	All four mic bias outputs are enabled.
		Reserved	0	—
		VP_MIN†	1	VP PSRR is optimized for a minimum voltage of 3.2 V.
		MIC_BIAS_CTRL[1:0]†	10	Mic bias outputs are 2.75 V.
9	Write the following registers to configure the volume controls.			
STEP TASK	REGISTER/BIT FIELDS	VALUE	DESCRIPTION	
9.1	Enable soft ramp on digital volume changes.	Soft Ramp Control, Address 0x1A	0x20	
		Reserved	00	—
		DIGSFT†	1	Digital volume changes occur with a soft ramp.
		Reserved	0 0000	—
9.2	Configure the ADC1A and ADC1B preamp and PGA settings.	ADC1A/1B AFE Control, Address 0x29–0x2A		
		ADC1A AFE Control, Address 0x29	0x40	
		ADC1A_PREAMP[1:0]†	01	ADC1A preamp gain is +10 dB.
		ADC1A_PGA_VOL[5:0]†	00 0000	ADC1A PGA is set to 0 dB.
		ADC1B AFE Control, Address 0x2A	0x40	
		ADC1B_PREAMP[1:0]†	01	ADC1B preamp gain is +10 dB.
		ADC1B_PGA_VOL[5:0]†	00 0000	ADC1B PGA is set to 0 dB.
9.3	Configure the ADC1A and ADC1B channel volumes.	ADC1A/1B Digital Volume, Address 0x2B–0x2C		
		ADC1A Digital Volume, Address 0x2B	0x00	
		ADC1A_VOL[7:0]†	0000 0000	ADC1A digital volume is set to 0 dB.
		ADC1B Digital Volume, Address 0x2C	0x00	
		ADC1B_VOL[7:0]†	0000 0000	ADC1B digital volume is set to 0 dB.

Example 5-1. Power-Up Sequence (Cont.)

STEP	TASK	REGISTER/BIT FIELDS	VALUE	DESCRIPTION		
9.4	Configure the ADC2A and ADC2B preamp and PGA settings.	ADC2A/2B AFE Control, Address 0x31–0x32				
		ADC2A AFE Control, Address 0x31	0x40			
		ADC2A_PREAMP[1:0]†	01	ADC2A preamp gain is +10 dB.		
		ADC2A_PGA_VOL[5:0]†	00 0000	ADC2A PGA is set to 0 dB.		
		ADC2B AFE Control, Address 0x32	0x40			
		ADC2B_PREAMP[1:0]†	01	ADC2B preamp gain is +10 dB.		
9.5	Configure the ADC2A and ADC2B channel volumes.	ADC2A/2B Digital Volume, Address 0x33–0x34				
		ADC2A Digital Volume, Address 0x33	0x00			
		ADC2A_VOL[7:0]†	0000 0000	ADC2A digital volume is set to 0 dB.		
		ADC2B Digital Volume, Address 0x34	0x00			
		ADC2B_VOL[7:0]†	0000 0000	ADC2B digital volume is set to 0 dB.		
		10	Write the following registers to power up the device.			
10.1	Enable TDM Mode.	ASP Control 1, Address 0x0D				
		ASP_TDM_PDN	0	TDM Mode is enabled.		
		ASP_SDOOUT1_PDN	0	ASP_SDOOUT1 output path is powered up.		
		ASP_3ST	0	ASP output clocks are active.		
		SHIFT_LEFT†	0	No shift.		
		Reserved	000	—		
		ASP_SDOOUT1_DRIVE†	0	The ASP_SDOOUT1 pin has normal drive strength.		
		10.2	Power up the device.	Power Control, Address 0x06		
				0x00		
				PDN_ULP	0	Ultralow power down is not enabled.
		PDN_LP	0	Power down is not enabled.		
		DISCHARGE_FILT+	0	FILT+ pin is not clamped to ground.		
		THMS_PDN†	0	Thermal sense is enabled.		
		Reserved	0000	—		

† Indicates bit fields for which the provided values are typical, but are not required for configuring the key functionality of the sequence. In the target application, these fields can be set as desired without affecting the configuration goal of this start-up sequence.

5.3 Power-Down Sequence

Ex. 5-2 is a procedure for powering down the device.

Example 5-2. Power-Down Sequence

STEP	TASK	REGISTER/BIT FIELDS	VALUE	DESCRIPTION
1	Write the following registers to mute the digital outputs.			
1.1	Mute Channels 1A and 1B.	ADC1A/1B Digital Volume, Address 0x2B–0x2C		
		ADC1A Digital Volume, Address 0x2B	0x80	
		ADC1A_VOL[7:0]	1000 0000	ADC1A digital volume is set to mute.
		ADC1B Digital Volume, Address 0x2C	0x80	
		ADC1B_VOL[7:0]	1000 0000	ADC1B digital volume is set to mute.
		1.2	Mute Channels 2A and 2B.	ADC2A/2B Digital Volume, Address 0x33–0x34
ADC2A Digital Volume, Address 0x33	0x80			
ADC2A_VOL[7:0]	1000 0000			ADC2A digital volume is set to mute.
ADC2B Digital Volume, Address 0x34	0x80			
ADC2B_VOL[7:0]	1000 0000			ADC2B digital volume is set to mute.
2	Read the interrupt status register to clear any previous PDN_DONE interrupts.			Device Interrupt Status, Address 0x36
		PDN_DONE	x	Indicates power down status.
		THMS_TRIP	x	Indicates thermal sense trip.
		SYNC_DONE	x	Indicates multichip synchronization sequence done.
		ADC2B_OVFL	x	Indicates overrange status in corresponding signal path.
		ADC2A_OVFL	x	Indicates overrange status in corresponding signal path.
		ADC1B_OVFL	x	Indicates overrange status in corresponding signal path.
		ADC1A_OVFL	x	Indicates overrange status in corresponding signal path.
		MUTE_PIN	x	Indicates MUTE pin assertion.

Example 5-2. Power-Down Sequence (Cont.)

STEP	TASK	REGISTER/BIT FIELDS	VALUE	DESCRIPTION
3	Write the following registers to power down the device.	Power Control, Address 0x06	0x90	
		PDN_ULP	1	Ultralow power down is enabled.
		PDN_LP	0	Power down is not enabled.
		DISCHARGE_FILT+	0	FILT+ pin is not clamped to ground.
		THMS_PDN	1	Thermal sense is powered down.
	Reserved	0000	—	
4	Poll the interrupt status register until the PDN_DONE status bit is set.	Device Interrupt Status, Address 0x36		
		PDN_DONE	1	Device has completely powered down.
		THMS_TRIP	x	Indicates thermal sense trip.
		SYNC_DONE	x	Indicates multichip synchronization sequence done.
		ADC2B_OVFL	x	Indicates overrange status in corresponding signal path.
		ADC2A_OVFL	x	Indicates overrange status in corresponding signal path.
		ADC1B_OVFL	x	Indicates overrange status in corresponding signal path.
		ADC1A_OVFL	x	Indicates overrange status in corresponding signal path.
		MUTE_PIN	x	Indicates MUTE pin assertion.
			Reserved	0000
5	(Optional) Discharge the FILT+ capacitor.	Power Control, Address 0x06	0xB0	
		PDN_ULP	1	Ultralow power down is enabled.
		PDN_LP	0	Power down is not enabled.
		DISCHARGE_FILT+	1	FILT+ pin is clamped to ground.
		THMS_PDN	1	Thermal sense is powered down.
	Reserved	0000	—	
6	(Optional) Remove MCLK.			
7	(Optional) Assert reset by driving the RESET pin low.			
8	(Optional) Remove power first from VA, then from VP.			

5.4 Capture-Path Inputs

The CS53L30 capture-path inputs can accept either analog or digital sources. This section describes the capture-path pins signal amplitude limitations.

5.4.1 Maximum Input Signal Level

Clipping mechanisms in the capture-path must be identified to quantify the maximum input signal level. The CS53L30 offers two such mechanisms:

- Clipping occurs if the input signal level exceeds the input pin-protection-diode turn-on voltage, as described in [Section 5.4.1.1](#).
- Clipping occurs if ADC full-scale input level is exceeded, as described in [Section 5.4.1.2](#).

5.4.1.1 Capture-Path Pin-Protection Diodes

The capture-path pins are specified with an absolute maximum rating ([Table 3-2](#)) that should not be exceeded; that is, the voltage at the IN± pins should not be higher than VA + 0.3 V or lower than GNDA – 0.3 V. The 0.3-V offsets from VA and GNDA are derived from the threshold voltage of the protection diodes used for voltage clamping at the capture-path pins.

[Fig. 5-2](#) and [Fig. 5-3](#) show the voltage relationship between a differential analog input signal and the absolute maximum rating of the capture-path pins.

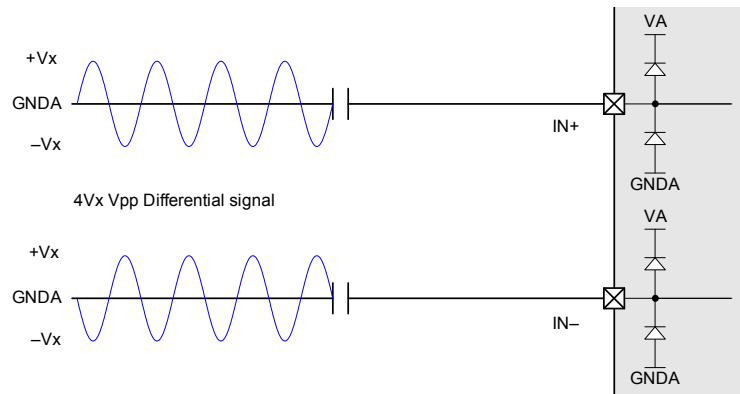

Figure 5-2. Differential Analog Input Signal to IN±, with Protection Diodes Shown

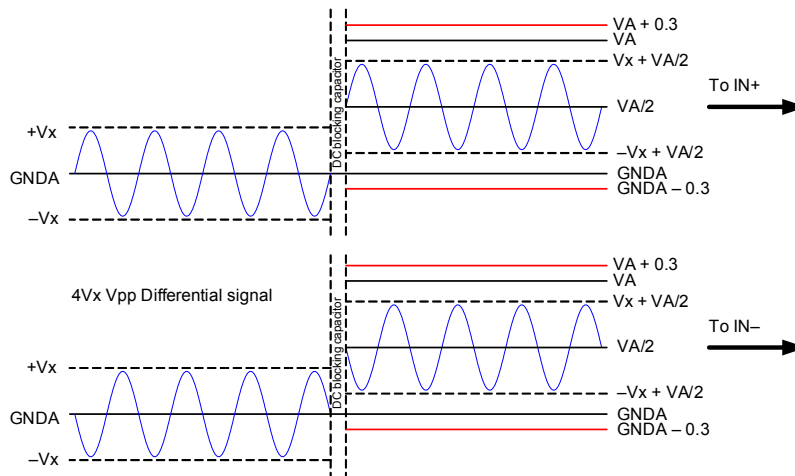

Figure 5-3. Differential Analog Input Signal to IN±, Voltage-Level Details Shown

As shown in Fig. 5-2, it is worth noting that a differential analog signal of $4 \cdot V_x V_{PP}$ actually delivers a $2 \cdot V_x V_{PP}$ signal centered around $V_A/2$ at each of the analog pin pairs. Thus, the signal peak (at the pin) of $V_x + V_A/2$ should not exceed $V_A + 0.3$ V; the signal trough of $-V_x + V_A/2$ (at the pin) should not be lower than $GNDA - 0.3$ V.

Although it is safe to use an input signal with resulting peak up to $V_A + 0.3$ V and trough of $GNDA - 0.3$ V at the pin, signal distortion at these maximum levels may be significant. This is caused by the onset of conduction of the protection diodes.

It is recommended that capture-path pin voltages stay between $GNDA$ and V_A to avoid signal distortion and clipping from the slightly conductive state of protection diodes in the V_A to $V_A + 0.3$ -V region and $GNDA - 0.3$ -V to $GNDA$ region.

5.4.1.2 ADC Fullscale Input Level

If the signal peaks are kept below the protection diode turn-on region per instructions in Section 5.4.1.1, the maximum capture-path signal level becomes solely a function of the applied analog gain, with the ADC fullscale input level being constant, hard limit for the path. Fig. 4-4 shows all analog gain blocks in the analog signal path in relation to the input pin and ADC. All signals levels mentioned refer to differential signals in V_{PP} .

For any given input pin pairs ($IN_{x\pm}$), the product of the signal level at those input pins and the total analog gain must be less than the ADC fullscale input level, i.e.,

$$\text{Input Signal Level} \times (\text{Preamp and PGA gain}) \leq \text{ADC Fullscale Input Level}$$

By rearranging terms, substituting register bit names for the analog gain stages, the following inequality is obtained:

$$\text{Input Signal Level} \leq 10^{-\left(\frac{\text{PREAMP}_x + \text{PGA}_x \text{VOL}}{20}\right)} \times (0.82) \times V_A$$

The ADC fullscale input level is specified in Table 3-5. PREAMP_x and $\text{PGA}_x \text{VOL}$ refer to the dB values set by the respective register bits.

5.5 MCLK Jitter

The following analog and digital specifications listed in [Section 3](#) are affected by MCLK jitter:

- INx-to-x_SDOOUT THD+N

The effect of MCLK jitter on THD+N is due to sampling at an unintended time, resulting in sample error. The resulting sample error is a function of the time error as a result of MCLK jitter and of the slope of the signal being sampled or reconstructed. To achieve the specified THD+N characteristics listed in [Section 3](#), the MCLK jitter should not exceed 1 ns peak-to-peak. The absolute jitter of a standard crystal oscillator is typically below 100-ps peak-to-peak and should meet the previously stated requirements.

5.6 Frequency Response Considerations

The ADC and SRC combined response referred to in [Table 3-3](#) shows the response from the capture-path inputs to the serial port outputs. This path includes two contributions to the frequency response of the CS53L30:

- ADC data path
- Synchronous SRC data path

The internal sample rate ($F_{S_{int}}$) of the CS53L30 is determined by MCLK, INTERNAL_FS_RATIO, MCLK_19MHZ_EN, and MCLK_INT_SCALE (see [Table 4-2](#)). The external sample rate ($F_{S_{ext}}$) is set by ASP_RATE. When the $F_{S_{int}}$ and the $F_{S_{ext}}$ are equal, the combined response of the ADC and the SRC has a lower –3-dB corner frequency than either would have alone. When $F_{S_{ext}}$ is lower than $F_{S_{int}}$, the frequency response of the SRC dominates; as a result, the combined frequency response has a higher –3 dB corner frequency than if $F_{S_{int}}$ and $F_{S_{ext}}$ were equal.

5.7 Connecting Unused Pins

Unused pins may be terminated or left unconnected, according to the recommendations in the following sections.

5.7.1 Analog Inputs

Unused differential analog input pin pairs (INx+ and INx-) may be left unconnected or tied directly to ground. If the pins are left unconnected, the input bias should be configured as weak pull-down (INxy_BIAS = 01). If the pins are tied directly to ground, the input bias should be configured as open (INxy_BIAS = 00) or weak pull-down (INxy_BIAS = 01). To minimize power consumption, the ADC associated with an unused differential input pin pair may be powered down.

When using single-ended inputs, the INx- pin must be tied to ground through a DC-blocking capacitor as shown in [Fig. 4-7](#). The same capacitor value should be used on both pins of the input pair (INx+ and INx-). Tying the INx- pin directly to ground may cause unexpected frequency response or distortion performance.

5.7.2 DMIC inputs

When the input channel type is set to digital, the input bias should be configured as weak pull-down (INxy_BIAS = 01) for all used and unused channels. Unused input pins may be left unconnected or tied directly to ground. The FILT+ pin may be left unconnected.

5.7.3 Mic Bias

Unused mic bias output pins (MICx_BIAS) may be left unconnected. If unconnected, the mic bias should be powered down (MICx_BIAS_PDN = 1). If none of the mic bias outputs are used, the mic bias filter pin (MIC_BIAS_FILT) may also be left unconnected.

6 Register Quick Reference

Default values are shown below the bit names.

Adr.	Function	7	6	5	4	3	2	1	0
0x00	Reserved	0	0	0	0	0	0	0	0
0x01	Device ID A and B p. 47 (Read Only)	DEVIDA[3:0]			DEVIDB[3:0]				
0x02	Device ID C and D p. 47 (Read Only)	DEVIDC[3:0]			DEVIDD[3:0]				
0x03	Device ID E (Read p. 47 Only)	DEVIDE[3:0]			—				
0x04	Reserved	0	0	0	0	0	0	0	0
0x05	Revision ID (Read p. 47 Only)	AREVID[3:0]			MTLREVID[3:0]				
0x06	Power Control p. 47	PDN_ULP	PDN_LP	DISCHARGE_	THMS_PDN	—			
		0	0	0	1	0	0	0	0
0x07	MCLK Control p. 48	MCLK_DIS	MCLK_INT_	DMIC_DRIVE	—	MCLK_DIV[1:0]		SYNC_EN	—
		0	0	0	0	0	1	0	0
0x08	Internal Sample Rate p. 48 Control	—			INTERNAL_FS_	—			MCLK_19MHZ_
		0	0	0	1	1	1	0	EN
0x09	Reserved	0	0	0	0	0	0	0	0
0x0A	Mic Bias Control p. 49	MIC4_BIAS_	MIC3_BIAS_	MIC2_BIAS_	MIC1_BIAS_	—	VP_MIN	MIC_BIAS_CTRL[1:0]	
		1	1	1	1	0	1	0	0
0x0B	Reserved	0	0	0	0	0	0	0	0
0x0C	ASP Configuration p. 49 Control	ASP_M/S	—	ASP_SCLK_INV		ASP_RATE[3:0]			
		0	0	0	0	1	1	0	0
0x0D	ASP Control 1 p. 49	ASP_TDM_PDN	ASP_SDOUT1_	ASP_3ST	SHIFT_LEFT	—			ASP_SDOUT1_
		1	0	0	0	0	0	0	DRIVE
0x0E	ASP TDM TX Control 1 p. 50	ASP_CH1_TX_	—	ASP_CH1_TX_LOC[5:0]					
		0	0	1	0	1	1	1	1
0x0F	ASP TDM TX Control 2 p. 50	ASP_CH2_TX_	—	ASP_CH2_TX_LOC[5:0]					
		0	0	1	0	1	1	1	1
0x10	ASP TDM TX Control 3 p. 50	ASP_CH3_TX_	—	ASP_CH3_TX_LOC[5:0]					
		0	0	1	0	1	1	1	1
0x11	ASP TDM TX Control 4 p. 50	ASP_CH4_TX_	—	ASP_CH4_TX_LOC[5:0]					
		0	0	1	0	1	1	1	1
0x12	ASP TDM TX Enable 1 p. 50	—			ASP_TX_ENABLE[47:40]				
		0	0	0	0	0	0	0	0
0x13	ASP TDM TX Enable 2 p. 50	—			ASP_TX_ENABLE[39:32]				
		0	0	0	0	0	0	0	0
0x14	ASP TDM TX Enable 3 p. 50	—			ASP_TX_ENABLE[31:24]				
		0	0	0	0	0	0	0	0
0x15	ASP TDM TX Enable 4 p. 50	—			ASP_TX_ENABLE[23:16]				
		0	0	0	0	0	0	0	0
0x16	ASP TDM TX Enable 5 p. 50	—			ASP_TX_ENABLE[15:8]				
		0	0	0	0	0	0	0	0
0x17	ASP TDM TX Enable 6 p. 50	—			ASP_TX_ENABLE[7:0]				
		0	0	0	0	0	0	0	0
0x18	ASP Control 2 p. 50	—	ASP_SDOUT2_	—			ASP_SDOUT2_		
		0	0	0	0	0	0	0	DRIVE
0x19	Reserved	0	0	0	0	0	0	0	0
0x1A	Soft Ramp Control p. 50	—		DIGSFT	—				
		0	0	0	0	0	0	0	0

Adr.	Function	7	6	5	4	3	2	1	0	
0x1B p. 51	LRCK Control 1	LRCK_TPWH[10:3]								
		0	0	0	0	0	0	0	0	
0x1C p. 51	LRCK Control 2	—				LRCK_50_NPW	LRCK_TPWH[2:0]			
		0	0	0	0	0	0	0	0	
0x1D– 0x1E	Reserved	—								
		0	0	0	0	0	0	0	0	
0x1F p. 51	MUTE Pin Control 1	MUTE_PDN_ULP	MUTE_PDN_LP	—	MUTE_M4B_PDN	MUTE_M3B_PDN	MUTE_M2B_PDN	MUTE_M1B_PDN	MUTE_MB_ALL_PDN	
		0	0	—	0	0	0	0	0	
0x20 p. 51	MUTE Pin Control 2	MUTE_PIN_POLARITY	MUTE_ASP_TDM_PDN	MUTE_ASP_SDOOUT2_PDN	MUTE_ASP_SDOOUT1_PDN	MUTE_ADC2B_PDN	MUTE_ADC2A_PDN	MUTE_ADC1B_PDN	MUTE_ADC1A_PDN	
		1	0	0	0	0	0	0	0	
0x21 p. 52	Input Bias Control 1	IN4M_BIAS[1:0]		IN4P_BIAS[1:0]		IN3M_BIAS[1:0]		IN3P_BIAS[1:0]		
		1	0	1	0	1	0	1	0	
0x22 p. 52	Input Bias Control 2	IN2M_BIAS[1:0]		IN2P_BIAS[1:0]		IN1M_BIAS[1:0]		IN1P_BIAS[1:0]		
		1	0	1	0	1	0	1	0	
0x23 p. 52	DMIC1 Stereo Control	—		DMIC1_STEREO_ENB	—					
		1	0	1	0	1	0	0	0	
0x24 p. 52	DMIC2 Stereo Control	—		DMIC2_STEREO_ENB	—					
		1	1	1	0	1	1	0	0	
0x25 p. 52	ADC1/DMIC1 Control 1	ADC1B_PDN	ADC1A_PDN	—			DMIC1_PDN	DMIC1_SCLK_DIV	CH_TYPE	
		0	0	0	0	0	1	0	0	
0x26 p. 53	ADC1/DMIC1 Control 2	ADC1_NOTCH_DIS	—	ADC1B_INV	ADC1A_INV	—		ADC1B_DIG_BOOST	ADC1A_DIG_BOOST	
		0	0	0	0	0	0	0	0	
0x27 p. 53	ADC1 Control 3	—				ADC1_HPF_EN	ADC1_HPF_CF[1:0]		ADC1_NG_ALL	
		0	0	0	0	1	0	0	0	
0x28 p. 54	ADC1 Noise Gate Control	ADC1B_NG	ADC1A_NG	ADC1_NG_BOOST	ADC1_NG_THRESH[2:0]			ADC1_NG_DELAY[1:0]		
		0	0	0	0	0	0	0	0	
0x29 p. 54	ADC1A AFE Control	ADC1A_PREAMP[1:0]		ADC1A_PGA_VOL[5:0]						
		0	0	0	0	0	0	0	0	
0x2A p. 54	ADC1B AFE Control	ADC1B_PREAMP[1:0]		ADC1B_PGA_VOL[5:0]						
		0	0	0	0	0	0	0	0	
0x2B p. 54	ADC1A Digital Volume	ADC1A_VOL[7:0]								
		0	0	0	0	0	0	0	0	
0x2C p. 54	ADC1B Digital Volume	ADC1B_VOL[7:0]								
		0	0	0	0	0	0	0	0	
0x2D p. 55	ADC2/DMIC2 Control 1	ADC2B_PDN	ADC2A_PDN	—			DMIC2_PDN	DMIC2_SCLK_DIV	—	
		0	0	0	0	0	1	0	0	
0x2E p. 55	ADC2/DMIC2 Control 2	ADC2_NOTCH_DIS	—	ADC2B_INV	ADC2A_INV	—		ADC2B_DIG_BOOST	ADC2A_DIG_BOOST	
		0	0	0	0	0	0	0	0	
0x2F p. 55	ADC2 Control 3	—				ADC2_HPF_EN	ADC2_HPF_CF[1:0]		ADC2_NG_ALL	
		0	0	0	0	1	0	0	0	
0x30 p. 56	ADC2 Noise Gate Control	ADC2B_NG	ADC2A_NG	ADC2_NG_BOOST	ADC2_NG_THRESH[2:0]			ADC2_NG_DELAY[1:0]		
		0	0	0	0	0	0	0	0	
0x31 p. 56	ADC2A AFE Control	ADC2A_PREAMP[1:0]		ADC2A_PGA_VOL[5:0]						
		0	0	0	0	0	0	0	0	
0x32 p. 56	ADC2B AFE Control	ADC2B_PREAMP[1:0]		ADC2B_PGA_VOL[5:0]						
		0	0	0	0	0	0	0	0	
0x33 p. 56	ADC2A Digital Volume	ADC2A_VOL[7:0]								
		0	0	0	0	0	0	0	0	
0x34 p. 56	ADC2B Digital Volume	ADC2B_VOL[7:0]								
		0	0	0	0	0	0	0	0	
0x35 p. 57	Device Interrupt Mask	M_PDN_DONE	M_THMS_TRIP	M_SYNC_DONE	M_ADC2B_OVFL	M_ADC2A_OVFL	M_ADC1B_OVFL	M_ADC1A_OVFL	M_MUTE_PIN	
		1	1	1	1	1	1	1	1	
0x36 p. 57	Device Interrupt Status (Read Only)	PDN_DONE	THMS_TRIP	SYNC_DONE	ADC2B_OVFL	ADC2A_OVFL	ADC1B_OVFL	ADC1A_OVFL	MUTE_PIN	
		x	x	x	x	x	x	x	x	
0x37– 0x7F	Reserved	—								
		0	0	0	0	0	0	0	0	

7 Register Descriptions

All registers are read/write except for the chip ID, revision register, and status registers, which are read only. Refer to the following bit definition tables for bit assignment information. The default state of each bit after a power-up sequence or reset is indicated. All reserved registers must maintain their default state.

7.1 Device ID A and B

Address 0x01

R/O	7	6	5	4	3	2	1	0
	DEVIDA[3:0]				DEVIDB[3:0]			
Default	0	1	0	1	0	0	1	1

7.2 Device ID C and D

Address 0x02

R/O	7	6	5	4	3	2	1	0
	DEVIDC[3:0]				DEVIDD[3:0]			
Default	1	0	1	0	0	0	1	1

7.3 Device ID E

Address 0x03

R/O	7	6	5	4	3	2	1	0
	DEVIDE[3:0]				—			
Default	0	0	0	0	0	0	0	0

Bits	Name	Description
7:4	DEVIDA DEVIDC DEVIDE	Device ID code for the CS53L30. DEVIDA 0x5 DEVIDB 0x3 DEVIDC 0xA Represents the “L” in CS53L30.
3:0	DEVIDB DEVIDD	DEVIDD 0x3 DEVIDE 0x0

7.4 Revision ID

Address 0x05

R/O	7	6	5	4	3	2	1	0
	AREVID[3:0]				MTLREVID[3:0]			
Default	x	x	x	x	x	x	x	x

Bits	Name	Description
7:4	AREVID	Alpha revision. CS53L30 alpha revision level. AREVID and MTLREVID form the complete device revision ID (e.g., A0, B2). 0xA A... 0xF F
3:0	MTLREVID	Metal revision. CS53L30 metal revision level. AREVID and MTLREVID form the complete device revision ID (e.g., A0, B2). 0x0 0... 0xF F

7.5 Power Control

Address 0x06

R/W	7	6	5	4	3	2	1	0
	PDN_ULP	PDN_LP	DISCHARGE_FILTER+	THMS_PDN	—			
Default	0	0	0	1	0	0	0	0

Bits	Name	Description
7	PDN_ULP	CS53L30 power down. Configures the power state of the entire device. After power-up (PDN_ULP: 1 → 0), subblocks stop ignoring their individual power controls and are powered according to their settings. PDN_ULP has precedence over PDN_LP (i.e., if PDN_ULP is set, the ADC and references are all powered down). 0 (Default) Powered up, as per the individual x_PDN controls. 1 Powered down. After PDN_ULP is set and the entire device is powered down, PDN_DONE is set, indicating that MCLK can be removed.
6	PDN_LP	Partial CS53L30 power down. Configures the power state of the device, with the exception of the reference circuits to allow for faster startup during power cycles. After power up (PDN_LP: 1 → 0), subblocks stop ignoring their individual power controls and are powered according to their settings. 0 (Default) Powered up, as per the individual x_PDN controls. 1 Powered down. Note: If PDN_ULP is set, the value of PDN_LP is ignored.

Bits	Name	Description
5	DISCHARGE_FILT+	Discharge FILT+ capacitor. Configures the state of the FILT+ pin internal clamp. Before setting this bit, ensure that the VA pin is connected to a supply, as described in Table 3-1 . 0 (Default) FILT+ is not clamped to ground. 1 FILT+ is clamped to ground. This must be set only if PDN_ULP or PDN_LP = 1. Discharge time with an external 2.2-μF capacitor on FILT+ is ~46 ms.
4	THMS_PDN	Thermal-sense power down. Configures the state of the power sense circuit. 0 Powered up. 1 (Default) Powered down.
3:0	—	Reserved

7.6 MCLK Control

Address 0x07

R/W	7	6	5	4	3	2	1	0
	MCLK_DIS	MCLK_INT_SCALE	DMIC_DRIVE	—	MCLK_DIV[1:0]	—	SYNC_EN	—
Default	0	0	0	0	0	1	0	0

Bits	Name	Description
7	MCLK_DIS	Master clock disable. Configures the state of the internal MCLK signal prior to its fanout to all internal circuitry. 0 (Default) On 1 Off; Disables the clock tree to save power when the device is powered down and the external MCLK is running. Note: The external MCLK must be running whenever this bit is altered.
6	MCLK_INT_SCALE	Internal MCLK scaling enable. Allows internal modulator rate to be scaled with the ASP_RATE setting to save power. 0 (Default) Off. MCLK _{INT} and FS _{INT} divide-ratio is 1. 1 On. Enables internal MCLK and FS _{INT} scaling. MCLK _{INT} and FS _{INT} divide ratio is either 2 or 4, depending on ASP_RATE and INTERNAL_FS_RATIO settings (see Table 4-2).
5	DMIC_DRIVE	DMIC clock output drive strength. Selects the drive strength used for the DMICx clock outputs. Table 3-14 describes drive-strength specifications. 0 (Default) Normal 1 Decreased
4	—	Reserved
3:2	MCLK_DIV	Master clock divide ratio. Selects the divide ratio between the selected MCLK source and the internal MCLK (MCLK _{INT}). Table 4-2 lists supported MCLK rates and their associated programming settings. 00 Divide by 1 01 (Default) Divide by 2 10 Divide by 3 11 Reserved • This field must be changed only if PDN_ULP or PDN_LP = 1 and MCLK_DIS = 1. • The control port's autoincrement feature is not supported on this bit field.
1	SYNC_EN	Multichip synchronization enable. Toggle high to enable synchronization sequence. 0 (Default) No activity 1 Begins multichip synchronization sequence. To restart the sequence this bit must be cleared and then set.
0	—	Reserved

7.7 Internal Sample Rate Control

Address 0x08

R/W	7	6	5	4	3	2	1	0
	—	—	—	INTERNAL_FS_RATIO	—	—	—	MCLK_19MHZ_EN
Default	0	0	0	1	1	1	0	0

Bits	Name	Description
7:5	—	Reserved
4	INTERNAL_FS_RATIO	Internal sample rate (FS _{int}). Selects the divide ratio from MCLK _{INT} to produce the internal sample rate used for all converters. Slave/Master Mode is determined by ASP_M/S on p. 49 . 0 MCLK _{INT} /125 1 (Default) MCLK _{INT} /128
3:1	—	Reserved
0	MCLK_19MHZ_EN	19.2-MHz MCLK enable. (Slave/Master Mode is determined by ASP_M/S on p. 49). 0 (Default) MCLK ≠ 19.2 MHz 1 MCLK = 19.2 MHz

7.8 Mic Bias Control

Address 0x0A

R/W	7	6	5	4	3	2	1	0
	MIC4_BIAS_PDN	MIC3_BIAS_PDN	MIC2_BIAS_PDN	MIC1_BIAS_PDN	—	VP_MIN	MIC_BIAS_CTRL[1:0]	
Default	1	1	1	1	0	1	0	0

Bits	Name	Description
7, 6, 5, 4	MICx_BIAS_PDN	Mic x bias power down 0 Mic x bias driver is powered up and its drive value is set by MIC_BIAS_CTRL. 1 (Default) Mic x bias driver is powered down and the driver is Hi-Z.
3	—	Reserved
2	VP_MIN	VP supply minimum voltage setting. Configures the internal circuitry to accept the VP supply with the specified minimum value. These settings also affect PSRR; see Table 3-7 . 0 3.0 V. Optimizes VP PSRR performance if the minimum VP supply is expected to fall below 3.2 V. 1 (Default) 3.2 V. Optimizes VP PSRR if VP is at least 3.2 V.
1:0	MIC_BIAS_CTRL	MICx bias output voltage control. Sets nominal MICx_BIAS output voltage. Table 3-6 lists actual voltages. To avoid long ramp-up times between 1.8- and 2.7-V settings, change to the Hi-Z setting before the final setting. 00 (Default) Hi-Z 01 1.80 V 10 2.75 V 11 Reserved

7.9 ASP Configuration Control

Address 0x0C

R/W	7	6	5	4	3	2	1	0
	ASP_M/S	—		ASP_SCLK_INV	ASP_RATE[3:0]			—
Default	0	0	0	0	1	1	0	0

Bits	Name	Description
7	ASP_M/S	ASP Master/Slave Mode. Configures the clock source (direction) for both ASPs. 0 (Default) Slave (input) 1 Master (output). When enabling Master Mode, ASP_RATE must be set to a valid setting defined in Section 4.6.5 .
6:5	—	Reserved
4	ASP_SCLK_INV	ASP_SCLK polarity. Configures the polarity of the ASP_SCLK signal. 0 (Default) Not inverted 1 Inverted
3:0	ASP_RATE	ASP clock control dividers. Together with the INTERNAL_FS_RATIO bit, provides divide ratios for ASP clock timings. Section 4.6.5 lists settings. 1100 (Default) 48 kHz

7.10 ASP Control 1

Address 0x0D

R/W	7	6	5	4	3	2	1	0
	ASP_TDM_PDN	ASP_SDOUT1_PDN	ASP_3ST	SHIFT_LEFT	—		ASP_SDOUT1_DRIVE	
Default	1	0	0	0	0	0	0	0

Bits	Name	Description
7	ASP_TDM_PDN	ASP TDM Mode power down. Configures the power state of TDM Mode. 0 TDM Mode 1 (Default) I ² S Mode
6	ASP_SDOUT1_PDN	ASP_SDOUT1 output path power down. Configures the ASP_SDOUT1 path power state for I ² S Mode (ASP_TDM_PDN = 1). 0 (Default) Powered up 1 Powered down, ASP_SDOUT1 is Hi-Z. Setting this bit does not tristate the serial port clock. If ASP_TDM_PDN is cleared, setting this bit does not affect ASP_SDOUT1.
5	ASP_3ST	ASP output path tristate. Determines the state of the ASP drivers. <u>Slave Mode (ASP_M/S = 0)</u> 0 (Default) Serial port clocks are inputs and ASP_SDOUTx is output 1 Serial port clocks are inputs and ASP_SDOUTx is Hi-Z <u>Master Mode (ASP_M/S = 1)</u> Serial port clocks and ASP_SDOUTx are outputs Serial port clocks and ASP_SDOUTx are Hi-Z
4	SHIFT_LEFT	TDM first bit of frame shift 1/2 SCLK left. Configures the start offset of data after rising edge of FSYNC. 0 (Default) No Shift. Data output on second rising edge of SCLK after rising edge of FSYNC (see Table 3-12). 1 1/2 SCLK shift left. Data output 1/2 SCLK cycle earlier (see Table 3-12).
3:1	—	Reserved
0	ASP_SDOUT1_DRIVE	ASP_SDOUT1 output drive strength. Table 3-14 describes drive-strength specifications. 0 (Default) Normal 1 Decreased

7.11 ASP TDM TX Control 1–4
Address 0x0E–0x11

R/W	7	6	5	4	3	2	1	0
	ASP_CHx_TX_STATE	—	ASP_CHx_TX_LOC[5:0]					
Default	0	0	1	0	1	1	1	1

Bits	Name	Description
7	ASP_CHx_TX_STATE	ASP TDM TX state control. Configures the state of the data for the ASP on Channel x. 0 (Default) Channel data is available 1 Channel data is not available
6	—	Reserved
5:0	ASP_CHx_TX_LOC	ASP TDM TX location control. Configures the first TDM slot in which the respective data set is to be transmitted on the ASP. Section 4.7 describes configuration and priorities. To avoid overlap, the following channel's start slot must also be configured. 00 0000 Slot 0 ... 10 1111 (Default) Slot 47 11 0000–11 1111 Reserved

7.12 ASP TDM TX Enable 1–6
Address 0x12–0x17

R/W	7	6	5	4	3	2	1	0
0x12	ASP_TX_ENABLE[47:40]							
0x13	ASP_TX_ENABLE[39:32]							
0x14	ASP_TX_ENABLE[31:24]							
0x15	ASP_TX_ENABLE[23:16]							
0x16	ASP_TX_ENABLE[15:8]							
0x17	ASP_TX_ENABLE[7:0]							
Default	0	0	0	0	0	0	0	0

Bits	Name	Description
7:0	ASP_TX_ENABLEx	ASP TDM TX Enable. Each bit individually enables or disables one of 48 slots for transmission on ASP_SDOU1 pin. TDM slots 7–0 are enabled by ASP_TX_ENABLE[7:0], slots 15–8 are enabled by ASP_TX_ENABLE[15:8], and so on. 0 (Default) Not enabled (Hi-Z) 1 Enabled (driven)

7.13 ASP Control 2
Address 0x18

R/W	7	6	5	4	3	2	1	0
	—	ASP_SDOU2_PDN	—			ASP_SDOU2_DRIVE		
Default	0	0	0	0	0	0	0	0

Bits	Name	Description
7	—	Reserved
6	ASP_SDOU2_PDN	ASP_SDOU2 output path power down. Configures the ASP_SDOU2 path's power state for I ² S Mode (ASP_TDM_PDN = 1). 0 (Default) Powered up 1 Powered down, ASP_SDOU2 is Hi-Z. Setting this bit does not tristate the serial port clock. If ASP_TDM_PDN is cleared, setting this bit does not affect ASP_SDOU2.
5:1	—	Reserved
0	ASP_SDOU2_DRIVE	ASP_SDOU2 output drive strength. Table 3-14 describes drive-strength specifications. 0 (Default) Normal 1 Decreased

7.14 Soft Ramp Control
Address 0x1A

R/W	7	6	5	4	3	2	1	0
	—	DIGSFT			—			
Default	0	0	0	0	0	0	0	0

Bits	Name	Description
7:6	—	Reserved
5	DIGSFT	Digital soft ramp. Configures an incremental volume ramp of all digital volumes from the current level to the new level. The soft ramp rate is fixed at 8 FS _{int} periods per step. Step size is fixed at 0.125 dB. 0 (Default) Do not occur with a soft ramp 1 Occurs with a soft ramp
4:0	—	Reserved

7.15 LRCK Control 1
Address 0x1B

R/W	7	6	5	4	3	2	1	0
	LRCK_TPWH[10:3]							
Default	0	0	0	0	0	0	0	0

Bits	Name	Description
7:0	LRCK_TPWH[10:3]	LRCK high-time pulse width [10:3]. With LRCK_TPWH[2:0], sets the number of SCLK cycles for which the LRCK remains high. Active only when in TDM Mode and LRCK_50_NPW = 1. 0x000 (Default) LRCK high time is 1 SCLK wide 0x001 LRCK high time is 2 SCLKs wide

7.16 LRCK Control 2
Address 0x1C

R/W	7	6	5	4	3	2	1	0
	—				LRCK_50_NPW	LRCK_TPWH[2:0]		
Default	0	0	0	0	0	0	0	0

Bits	Name	Description
7:4	—	Reserved
3	LRCK_50_NPW	LRCK either 50% duty cycle or programmable high-time pulse width. In TDM Mode, pulse width can be 50% or programmable up to 2047 x SCLK cycles. 0 (Default) High-time pulse width set by LRCK_TPWH[10:0]. 1 50% duty cycle
2:0	LRCK_TPWH[2:0]	LRCK high time pulse width [2:0]. With LRCK_TPWH[10:3], sets the LRCK high time in TDM Mode. See Section 7.15 .

7.17 MUTE Pin Control 1
Address 0x1F

R/W	7	6	5	4	3	2	1	0
	MUTE_PDN_ULP	MUTE_PDN_LP	—	MUTE_M4B_PDN	MUTE_M3B_PDN	MUTE_M2B_PDN	MUTE_M1B_PDN	MUTE_MB_ALL_PDN
Default	0	0	0	0	0	0	0	0

Bits	Name	Description
7	MUTE_PDN_ULP	Power down all ADCs, references, and mic biases when the MUTE pin is asserted. 0 (Default) Not affected by MUTE pin 1 Powered down when MUTE pin asserted
6	MUTE_PDN_LP	Power down all ADCs and mic biases when the MUTE pin is asserted. 0 (Default) Not affected by MUTE pin 1 Powered down when MUTE pin asserted
5	—	Reserved
4, 3, 2, 1	MUTE_MxB_PDN	Individual power down controls for the MICx biases when the MUTE pin is asserted. 0 (Default) Not affected by MUTE pin 1 Powered down when MUTE pin asserted
0	MUTE_MB_ALL_PDN	Power down all mic biases when the MUTE pin is asserted. 0 (Default) Not affected by MUTE pin 1 Powered down when MUTE pin asserted

7.18 MUTE Pin Control 2
Address 0x20

R/W	7	6	5	4	3	2	1	0
	MUTE_PIN_POLARITY	MUTE_ASP_TDM_PDN	MUTE_ASP_SDOOUT2_PDN	MUTE_ASP_SDOOUT1_PDN	MUTE_ADC2B_PDN	MUTE_ADC2A_PDN	MUTE_ADC1B_PDN	MUTE_ADC1A_PDN
Default	1	0	0	0	0	0	0	0

Bits	Name	Description
7	MUTE_PIN_POLARITY	MUTE pin polarity. 0 MUTE pin is active low. 1 (Default) MUTE pin is active high.
6	MUTE_ASP_TDM_PDN	Power down TDM when MUTE pin is asserted. 0 (Default) Not affected by MUTE pin. 1 If MUTE_ASP_SDOOUT1_PDN is set, the TDM interface is powered down when MUTE pin is asserted.
5	MUTE_ASP_SDOOUT2_PDN	Power down ASP_SDOOUT2 when MUTE pin is asserted. Setting is ignored in TDM Mode. 0 (Default) Not affected by MUTE pin. 1 Powered down when MUTE pin asserted.

Bits	Name	Description
4	MUTE_ASP_SDOUT1_PDN	Power down ASP_SDOUT1 when MUTE pin is asserted. Setting is ignored in TDM Mode. 0 (Default) Not affected by MUTE pin. 1 Powered down when MUTE pin asserted.
3, 2, 1, 0	MUTE_ADCxy_PDN	Individual power down controls for the ADCs when the MUTE pin is asserted. 0 (Default) Not affected by MUTE pin 1 Powered down when MUTE pin asserted

7.19 Input Bias Control 1

Address 0x21

R/W	7	6	5	4	3	2	1	0
	IN4M_BIAS[1:0]		IN4P_BIAS[1:0]		IN3M_BIAS[1:0]		IN3P_BIAS[1:0]	
Default	1	0	1	0	1	0	1	0

7.20 Input Bias Control 2

Address 0x22

R/W	7	6	5	4	3	2	1	0
	IN2M_BIAS[1:0]		IN2P_BIAS[1:0]		IN1M_BIAS[1:0]		IN1P_BIAS[1:0]	
Default	1	0	1	0	1	0	1	0

Bits	Name	Description
7:6, 5:4, 3:2, 1:0	INxy_BIAS	Input xy pin bias control. Controls the input pin bias configuration. 00 Open. Set if no pin bias is desired. The pin is always unbiased in this state. 01 Weakly pulled down. Set if an internal weak pulldown is desired on the input pin. 10 (Default) Weak VCM. Set if weak VCM is desired, biased to weak VCM when necessary. 11 Reserved

7.21 DMIC1 Stereo Control

Address 0x23

R/W	7	6	5	4	3	2	1	0
	—		DMIC1_STEREO_ENB	—		—		
Default	1	0	1	0	1	0	0	0

7.22 DMIC2 Stereo Control

Address 0x24

R/W	7	6	5	4	3	2	1	0
	—		DMIC2_STEREO_ENB	—		—		
Default	1	1	1	0	1	1	0	0

Bits	Name	Description
7:6	—	Reserved
5	DMICx_STEREO_ENB	DMIC2 stereo/mono enable. 0 Stereo input from the digital mic DMIC2_SD pin is enabled. 1 (Default) Mono (left-channel or rising-edge data) from DMIC2 is enabled and stereo is disabled.
4:0	—	Reserved

7.23 ADC1/DMIC1 Control 1

Address 0x25

R/W	7	6	5	4	3	2	1	0
	ADC1B_PDN	ADC1A_PDN	—		DMIC1_PDN	DMIC1_SCLK_DIV	CH_TYPE	
Default	0	0	0	0	0	1	0	0

Bits	Name	Description
7, 6	ADC1x_PDN	ADC1x power down. Configures the ADC Channel x power state. All analog front-end circuitry (preamp, PGA, etc.) associated with that channel is powered up or down accordingly. Also enables the digital decimator associated with that channel and must be cleared if the input channel type is digital. 0 (Default) Powered up 1 Powered down
5:3	—	Reserved
2	DMIC1_PDN	Power down digital mic clock. Determines the power state of the digital mic interface clock. 0 Powered up 1 (Default) Powered down.

Bits	Name	Description
1	DMIC1_SCLK_DIV	DMIC1 clock divide ratio. Selects the divide ratio between the internal MCLK and the digital mic interface clock output. Section 4.5 lists supported digital mic interface shift clock rates and their associated programming settings. 0 (Default) $64 \cdot F_{S_{int}}$ 1 $32 \cdot F_{S_{int}}$
0	CH_TYPE	Input channel type. Sets the capture-path pins to be either all analog (analog mic/line-in) or all digital mic. 0 (Default) Analog inputs. Do not connect digital mic data lines to any of the capture-path pins when selected. 1 Digital inputs. Do not connect analog source to any capture-path pins when selected.

7.24 ADC1/DMIC1 Control 2
Address 0x26

R/W	7	6	5	4	3	2	1	0
	ADC1_NOTCH_DIS	—	ADC1B_INV	ADC1A_INV	—		ADC1B_DIG_BOOST	ADC1A_DIG_BOOST
Default	0	0	0	0	0	0	0	0

Bits	Name	Description
7	ADC1_NOTCH_DIS	ADC1 digital notch filter disable. Disables the digital notch filter on ADC1. 0 (Default) Enabled 1 Disabled
6	—	Reserved
5,4	ADC1x_INV	ADC1x invert signal polarity. Configures the polarity of the ADC1 Channel x signal. 0 (Default) Not inverted 1 Inverted
3:2	—	Reserved
1,0	ADC1x_DIG_BOOST	ADC1x digital boost. Configures a +20-dB digital boost on the ADC1 or DMIC signal on Channel x, based on the input source selected (see Table 4-5). 0 (Default) No boost applied 1 +20-dB digital boost applied

7.25 ADC1 Control 3
Address 0x27

R/W	7	6	5	4	3	2	1	0
			—		ADC1_HPF_EN	ADC1_HPF_CF[1:0]		ADC1_NG_ALL
Default	0	0	0	0	1	0	0	0

Bits	Name	Description
7:4	—	Reserved
3	ADC1_HPF_EN	ADC1 high-pass filter enable. Configures the internal HPF after ADC1. Change only if the ADC is in a powered down state. 0 Disabled. Clear for test purposes only. 1 (Default) Enabled
2:1	ADC1_HPF_CF	ADC1 HPF corner frequency. Sets the corner frequency (–3-dB point) for the internal HPF. 00 (Default) $3.88 \times 10^{-5} \times F_{S_{int}}$ (1.86 Hz at $F_{S_{int}} = 48$ kHz). 10 $4.9 \times 10^{-3} \times F_{S_{int}}$ (235 Hz at $F_{S_{int}} = 48$ kHz) 01 $2.5 \times 10^{-3} \times F_{S_{int}}$ (120 Hz at $F_{S_{int}} = 48$ kHz) 11 $9.7 \times 10^{-3} \times F_{S_{int}}$ (466 Hz at $F_{S_{int}} = 48$ kHz) Increasing the HPF corner frequency past the default setting can introduce up to ~0.3 dB of gain in the passband.
0	ADC1_NG_ALL	ADC1 noise-gate ganging. Configures Channel A and B noise gating as independent (see ADC1x_NG) or ganged. 0 (Default) Independent noise gating on Channels A and B 1 Ganged noise gating on Channels A and B. Noise gate muting is applied to both channels when the signal amplitude of both channels remains below the noise gate AB minimum threshold (refer to ADC1_NG_THRESH on p. 54) for longer than the attack delay (debounce) time (refer to ADC1_NG_DELAY on p. 54). • Noise gate muting is removed (released) without debouncing when the signal level exceeds the threshold. • Noise gate attack and release rates (soft-ramped as a function of F_s or abrupt) are set according to DIGSFT on p. 50.

7.26 ADC1 Noise Gate Control
Address 0x28

R/W	7	6	5	4	3	2	1	0
	ADC1B_NG		ADC1A_NG	ADC1_NG_BOOST		ADC1_NG_THRESH[2:0]		ADC1_NG_DELAY[1:0]
Default	0	0	0	0	0	0	0	0

Bits	Name	Description																											
7,6	ADC1x_NG	ADC1 noise gate enable for Channels A and B. Enables independent noise gating for Channels A and B if ADC1_NG_ALL = 0. This bit has no effect if ADC1_NG_ALL = 1 0 (Default) Disable noise gating on Channel x 1 Enable noise gating on Channel x. If a channel's signal amplitude remains below the threshold setting (refer to ADC1_NG_THRESH) for longer than the attack delay (debounce) time (refer to ADC1_NG_DELAY), noise gate muting is applied to only that channel. <ul style="list-style-type: none"> Noise gate muting is removed (released) without debouncing when the signal level exceeds the threshold. Noise gate attack and release rates (soft-ramped as a function of Fs or abrupt) are set according to DIGSFT on p. 50. 																											
5	ADC1_NG_BOOST	ADC1 noise gate threshold and boost for Channels A and B. These fields define the signal level where the noise gate begins to engage. For low settings, the noise gate may not fully engage until the signal level is a few dB lower. Sets threshold level (± 2 dB) for Channel A and B noise gates. ADC1_NG_BOOST configures a +30-dB boost to the threshold setting.																											
4:2	ADC1_NG_THRESH	<table border="1"> <thead> <tr> <th>ADC1_NG_THRESH</th> <th>Minimum Setting (ADC1_NG_BOOST = 0)</th> <th>Minimum Setting (ADC1_NG_BOOST = 1)</th> </tr> </thead> <tbody> <tr><td>000</td><td>(Default) -64 dB</td><td>-34 dB</td></tr> <tr><td>001</td><td>-66 dB</td><td>-36 dB</td></tr> <tr><td>010</td><td>-70 dB</td><td>-40 dB</td></tr> <tr><td>011</td><td>-73 dB</td><td>-43 dB</td></tr> <tr><td>100</td><td>-76 dB</td><td>-46 dB</td></tr> <tr><td>101</td><td>-82 dB</td><td>-52 dB</td></tr> <tr><td>110</td><td>Reserved</td><td>-58 dB</td></tr> <tr><td>111</td><td>Reserved</td><td>-64 dB</td></tr> </tbody> </table>	ADC1_NG_THRESH	Minimum Setting (ADC1_NG_BOOST = 0)	Minimum Setting (ADC1_NG_BOOST = 1)	000	(Default) -64 dB	-34 dB	001	-66 dB	-36 dB	010	-70 dB	-40 dB	011	-73 dB	-43 dB	100	-76 dB	-46 dB	101	-82 dB	-52 dB	110	Reserved	-58 dB	111	Reserved	-64 dB
ADC1_NG_THRESH	Minimum Setting (ADC1_NG_BOOST = 0)	Minimum Setting (ADC1_NG_BOOST = 1)																											
000	(Default) -64 dB	-34 dB																											
001	-66 dB	-36 dB																											
010	-70 dB	-40 dB																											
011	-73 dB	-43 dB																											
100	-76 dB	-46 dB																											
101	-82 dB	-52 dB																											
110	Reserved	-58 dB																											
111	Reserved	-64 dB																											
1:0	ADC1_NG_DELAY	Noise gate delay timing for ADC1 Channels A and B. Sets the delay (debounce) time before the noise gate mute attacks. Time base = $(6144 \times (\text{MCLK}_{\text{INT}} \text{ scaling factor})) / \text{MCLK}_{\text{INT}}$ 00 (Default) 50 x (time base) ms 01 100 x (time base) ms 10 150 x (time base) ms 11 200 x (time base) ms MCLK _{INT} scaling factor is 1, 2, or 4, depending on F _{SINT} and the MCLK_INT_SCALE setting. Table 4-2 lists supported configurations and their corresponding MCLK _{INT} scaling factors. For MCLK _{INT} = 6.144 MHz and MCLK_INT_SCALE = 0, time base is 1 ms.																											

7.27 ADC1A/1B AFE Control
Address 0x29–0x2A

R/W	7	6	5	4	3	2	1	0
	ADC1A_PREAMP[1:0]			ADC1A_PGA_VOL[5:0]				
	ADC1B_PREAMP[1:0]			ADC1B_PGA_VOL[5:0]				
Default	0	0	0	0	0	0	0	0

Bits	Name	Description
7:6	ADC1x_PREAMP	ADC1x mic preamp gain. Sets the gain of the mic preamp on Channel x. 00 (Default) 0 dB (preamp bypassed) 10 +20 dB 01 +10 dB 11 Reserved
5:0	ADC1x_PGA_VOL	ADC1x PGA volume. Sets PGA attenuation/gain. Step size: ~0.5 dB. 01 1111–01 1000 +12 dB ... 11 1111 –0.5 dB ... 00 0001 +0.5 dB 11 1010 –3.0 dB (target setting for 600-mVrms analog-input amplitude) 00 0000 (Default) 0 dB ... 11 0100–10 0000 –6.0 dB

7.28 ADC1A/1B Digital Volume
Address 0x2B–0x2C

R/W	7	6	5	4	3	2	1	0
	ADC1A_VOL[7:0]							
	ADC1B_VOL[7:0]							
Default	0	0	0	0	0	0	0	0

Bits	Name	Description
7:0	ADC1x_VOL	ADC1x/DMICx digital volume. Sets the ADC1 or DMIC signal volume of on Channel x based on the input source selected (see Table 4-5). Step size: 1.0 dB 0111 1111–0000 1100 +12 dB 1111 1111 –1.0 dB 1001 1111–1000 0000 Mute 0000 1011 +11 dB ... 1111 1110 –2.0 dB ... 0000 0000 (Default) 0 dB 1010 0000 –96.0 dB

7.29 ADC2/DMIC2 Control 1
Address 0x2D

R/W	7	6	5	4	3	2	1	0
	ADC2B_PDN	ADC2A_PDN		—		DMIC2_PDN	DMIC2_SCLK_DIV	—
Default	0	0	0	0	0	1	0	0

Bits	Name	Description
7,6	ADC2x_PDN	ADC2x power down. Configures the ADC Channel x power state, including all associated analog front-end circuitry (preamp, PGA, etc.). Enables the channel's digital decimator associated. Must be cleared if the input channel type is digital. 0 (Default) Powered up 1 Powered down
5:3	—	Reserved
2	DMIC2_PDN	Power down digital mic clock. Determines the power state of the digital mic interface clock 0 Powered up 1 (Default) Powered down
1	DMIC2_SCLK_DIV	DMIC2 clock divide ratio. Selects the divide ratio between the internal MCLK and the digital mic interface clock output. Section 4.5 lists supported digital mic interface shift clock rates and their associated programming settings. 0 (Default) $64 \cdot F_{s_{int}}$ 1 $32 \cdot F_{s_{int}}$
0	—	Reserved

7.30 ADC2/DMIC2 Control 2
Address 0x2E

R/W	7	6	5	4	3	2	1	0
	ADC2_NOTCH_DIS	—	ADC2B_INV	ADC2A_INV	—		ADC2B_DIG_BOOST	ADC2A_DIG_BOOST
Default	0	0	0	0	0	0	0	0

Bits	Name	Description
7	ADC2_NOTCH_DIS	ADC2 digital notch filter disable. Disables the digital notch filter on ADC2. 0 (Default) Enabled 1 Disabled
6	—	Reserved
5,4	ADC2x_INV	ADC2x invert signal polarity. Configures the polarity of the ADC2 Channel x signal. 0 (Default) Not inverted 1 Inverted
3:2	—	Reserved
1,0	ADC2x_DIG_BOOST	ADC2x digital boost. Configures a +20-dB digital boost on the ADC2 or DMIC signal, based on the input source (see Table 4-5). 0 (Default) No boost applied 1 +20-dB digital boost applied

7.31 ADC2 Control 3
Address 0x2F

R/W	7	6	5	4	3	2	1	0
			—		ADC2_HPF_EN	ADC2_HPF_CF[1:0]		ADC2_NG_ALL
Default	0	0	0	0	1	0	0	0

Bits	Name	Description
7:4	—	Reserved
3	ADC2_HPF_EN	ADC2 HPF enable. Configures the internal HPF after ADC2. Change only if the ADC is in a powered down state. 0 Disabled. Clear for test purposes only. 1 (Default) Enabled
2:1	ADC2_HPF_CF	ADC2 HPF corner frequency. Sets the corner frequency (–3-dB point) for the internal HPF. Increasing the HPF corner frequency past the default setting can introduce up to ~0.3 dB of gain in the passband. 00 (Default) $3.88 \times 10^{-5} \times F_{s_{int}}$ (1.86 Hz at $F_{s_{int}} = 48$ kHz). 10 $4.9 \times 10^{-3} \times F_{s_{int}}$ (235 Hz at $F_{s_{int}} = 48$ kHz) 01 $2.5 \times 10^{-3} \times F_{s_{int}}$ (120 Hz at $F_{s_{int}} = 48$ kHz) 11 $9.7 \times 10^{-3} \times F_{s_{int}}$ (466 Hz at $F_{s_{int}} = 48$ kHz)
0	ADC2_NG_ALL	ADC2 noise-gate ganging. Configures noise gating for Channels A and B as independent (see ADC1x_NG) or ganged. 0 (Default) Independent noise gating on Channels A and B 1 Ganged noise gating on Channels A and B. Noise gate muting is applied to both channels if the signal amplitude of both remains below the noise gate AB minimum threshold (see ADC1_NG_THRESH) for longer than the attack delay (debounce) time (see ADC1_NG_DELAY). • Noise-gate muting is removed (released) without debouncing when the signal level exceeds the threshold. • Noise-gate attack and release rates (soft-ramped as a function of F_s or abrupt) are set according to DIGSFT .

7.32 ADC2 Noise Gate Control
Address 0x30

R/W	7	6	5	4	3	2	1	0
	ADC2B_NG	ADC2A_NG	ADC2_NG_BOOST	ADC2_NG_THRESH[2:0]		ADC2_NG_DELAY[1:0]		
Default	0	0	0	0	0	0	0	0

Bits	Name	Description																											
7:6	ADC2x_NG	ADC2 noise-gate enable for Channels A and B. Enables independent noise gating for Channels A and B if ADC1_NG_ALL = 0. This bit has no effect if ADC1_NG_ALL = 1 0 (Default) Disable noise gating on Channel x 1 Enable noise gating on Channel x. If a channel's signal amplitude remains below the threshold setting (refer to ADC2_NG_THRESH) for longer than the attack delay (debounce) time (refer to ADC2_NG_DELAY), noise gate muting is applied to only that channel. <ul style="list-style-type: none"> Noise gate muting is removed (released) without debouncing when the signal level exceeds the threshold. Noise gate attack and release rates (soft-ramped as a function of Fs or abrupt) are set according to DIGSFT on p. 50. 																											
5	ADC2_NG_BOOST	ADC2 noise-gate threshold and boost for Channels A and B. These fields define the signal level where the noise gate begins to engage. For low settings, the noise gate may not fully engage until the signal level is a few dB lower. Sets threshold level (± 2 dB) for Channel A and B noise gates. ADC2_NG_BOOST configures a +30-dB boost to the threshold setting.																											
4:2	ADC2_NG_THRESH	<table border="1"> <thead> <tr> <th>ADC2_NG_THRESH</th> <th>Minimum Setting (ADC2_NG_BOOST = 0)</th> <th>Minimum Setting (ADC2_NG_BOOST = 1)</th> </tr> </thead> <tbody> <tr><td>000</td><td>(Default) -64 dB</td><td>-34 dB</td></tr> <tr><td>001</td><td>-66 dB</td><td>-36 dB</td></tr> <tr><td>010</td><td>-70 dB</td><td>-40 dB</td></tr> <tr><td>011</td><td>-73 dB</td><td>-43 dB</td></tr> <tr><td>100</td><td>-76 dB</td><td>-46 dB</td></tr> <tr><td>101</td><td>-82 dB</td><td>-52 dB</td></tr> <tr><td>110</td><td>Reserved</td><td>-58 dB</td></tr> <tr><td>111</td><td>Reserved</td><td>-64 dB</td></tr> </tbody> </table>	ADC2_NG_THRESH	Minimum Setting (ADC2_NG_BOOST = 0)	Minimum Setting (ADC2_NG_BOOST = 1)	000	(Default) -64 dB	-34 dB	001	-66 dB	-36 dB	010	-70 dB	-40 dB	011	-73 dB	-43 dB	100	-76 dB	-46 dB	101	-82 dB	-52 dB	110	Reserved	-58 dB	111	Reserved	-64 dB
ADC2_NG_THRESH	Minimum Setting (ADC2_NG_BOOST = 0)	Minimum Setting (ADC2_NG_BOOST = 1)																											
000	(Default) -64 dB	-34 dB																											
001	-66 dB	-36 dB																											
010	-70 dB	-40 dB																											
011	-73 dB	-43 dB																											
100	-76 dB	-46 dB																											
101	-82 dB	-52 dB																											
110	Reserved	-58 dB																											
111	Reserved	-64 dB																											
1:0	ADC2_NG_DELAY	Noise-gate delay timing for ADC2 Channels A and B. Sets the delay (debounce) time before the noise gate mute attacks. 00 (Default) 50 * (time base) ms 01 100 * (time base) ms 10 150 * (time base) ms 11 200 * (time base) ms Time base = (6144 x [MCLK _{INT} scaling factor])/MCLK _{INT} . MCLK _{INT} scaling factor is 1, 2, or 4, depending on FS _{INT} and the MCLK_INT_SCALE setting. Table 4-2 lists supported configurations and their corresponding MCLK _{INT} scaling factors. For MCLK _{INT} = 6.144 MHz and MCLK_INT_SCALE = 0, time base is 1 ms.																											

7.33 ADC2A/2B AFE Control
Address 0x31–0x32

R/W	7	6	5	4	3	2	1	0
	ADC2A_PREAMP[1:0]		ADC2A_PGA_VOL[5:0]					
	ADC2B_PREAMP[1:0]		ADC2B_PGA_VOL[5:0]					
Default	0	0	0	0	0	0	0	0

Bits	Name	Description
7:6	ADC2x_PREAMP	ADC2x mic preamp gain. Sets the gain of the mic preamp. 00 (Default) 0 dB (preamp bypassed) 10 +20 dB 01 +10 dB 11 Reserved
5:0	ADC2x_PGA_VOL	ADC2x PGA volume. Sets PGA attenuation/gain. Step size: ~0.5 dB. 01 1111–01 1000 12 dB... 11 1111 -0.5 dB 00 0001 +0.5 dB 11 1010 -3.0 dB (Target setting for 600-mVrms analog-input amplitude)... 00 0000 (Default) 0 dB 11 0100–10 0000 -6.0 dB

7.34 ADC2A/2B Digital Volume
Address 0x33–0x34

R/W	7	6	5	4	3	2	1	0
	ADC2A_VOL[7:0]				ADC2B_VOL[7:0]			
Default	0	0	0	0	0	0	0	0

Bits	Name	Description
7:0	ADC2x_VOL	ADC2x digital volume. Sets the ADC2x or DMIC signal volume based on the input source (see Table 4-5). Step size: 1.0 dB. 0111 1111–0000 1100 +12 dB 0000 0000(Default) 0 dB 1111 1110 -2.0 dB... 1001 1111 -1000 0000 Mute 0000 1011 +11 dB ... 1111 1111 -1.0 dB 1010 0000 -96.0 dB

7.35 Device Interrupt Mask
Address 0x35

R/W	7	6	5	4	3	2	1	0
	M_PDN_DONE	M_THMS_TRIP	M_SYNC_DONE	M_ADC2B_OVFL	M_ADC2A_OVFL	M_ADC1B_OVFL	M_ADC1A_OVFL	M_MUTE_PIN
Default	1	1	1	1	1	1	1	1

Interrupt mask register bits serve as a mask for the interrupt sources in the interrupt status registers. Interrupts are described in [Section 4.3](#). Registers at addresses 0x35 and 0x36 must not be part of a control-port autoincremented read and must be read individually. See [Section 4.14](#).

Bits	Name	Description
7	M_PDN_DONE	PDN_DONE mask 0 Unmasked 1 (Default) Masked
6	M_THMS_TRIP	THMS_TRIP mask 0 Unmasked 1 (Default) Masked
5	M_SYNC_DONE	SYNC_DONE mask 0 Unmasked 1 (Default) Masked
4:1	M_ADCxy_OVFL	DMICx/ADCx_OVFL mask. 0 Unmasked 1 (Default) Masked
0	M_MUTE_PIN	MUTE_PIN mask 0 Unmasked 1 (Default) Masked

7.36 Device Interrupt Status
Address 0x36

R/O	7	6	5	4	3	2	1	0
	PDN_DONE	THMS_TRIP	SYNC_DONE	ADC2B_OVFL	ADC2A_OVFL	ADC1B_OVFL	ADC1A_OVFL	MUTE_PIN
Default	x	x	x	x	x	x	x	x

Interrupt status bits are read only and sticky. Interrupts are described in [Section 4.3](#). Registers at addresses 0x35 and 0x36 must not be part of a control-port autoincremented read and must be read only individually. See [Section 4.14](#).

Bits	Name	Description
7	PDN_DONE	Power down done. Indicates when the device has powered down and MCLK can be stopped. 0 Not completely powered down 1 Powered down as a result of PDN_ULP having been set
6	THMS_TRIP	Thermal sensor trip. If thermal sensing is enabled, this bit indicates whether the current junction temperature has exceeded the safe operating limits. See Section 4.11 . 0 Junction temperature is within safe operating limits. 1 Junction temperature has exceeded safe operating limits.
5	SYNC_DONE	Multichip synchronization sequence done. Indicates that the device has received and confirmed the synchronization protocol. 0 SYNC protocol has not been received. 1 SYNC protocol has been received and confirmed.
4:1	ADCxy_OVFL	Indicates the overrange status in the corresponding signal path. Rising-edge state transitions may cause an interrupt, depending on the programming of the associated interrupt mask bit. 0 No digital clipping has occurred in the data path of the indicated digital ADC 1 Digital clipping has occurred in the data path of the indicated digital ADC
0	MUTE_PIN	MUTE pin asserted. Indicates that the MUTE pin has been asserted. 0 MUTE pin not asserted 1 MUTE pin asserted

8 Parameter Definitions

Dynamic range. The ratio of the rms value of the signal to the rms sum of all other spectral components over the specified bandwidth. Dynamic range is a signal-to-noise ratio measurement over the specified band width made with a -60 dB signal.

Frequency response. A measure of the amplitude response variation from 10 Hz to 20 kHz relative to the amplitude response at 1 kHz. Frequency response is expressed in decibel units.

Gain drift. The change in gain value with temperature, expressed in ppm/ $^{\circ}$ C units.

Interchannel gain mismatch. The gain difference between left and right channel pairs. Interchannel gain mismatch is expressed in decibel units.

Interchannel isolation. A measure of crosstalk between the left- and right-channel pairs. Interchannel Isolation is measured for each channel at the converter's output with no signal to the input under test and a full-scale signal applied to the other channel. Interchannel isolation is expressed in decibel units.

Load resistance and capacitance. The recommended minimum resistance and maximum capacitance required for the internal op-amp's stability and signal integrity. The load capacitance effectively moves the band-limiting pole of the amp in the output stage. Increasing the load capacitance beyond the recommended value can cause the internal op-amp to become unstable.

9 Plots

9.1 Digital Filter Response

9.1.1 ADC High-Pass Filter

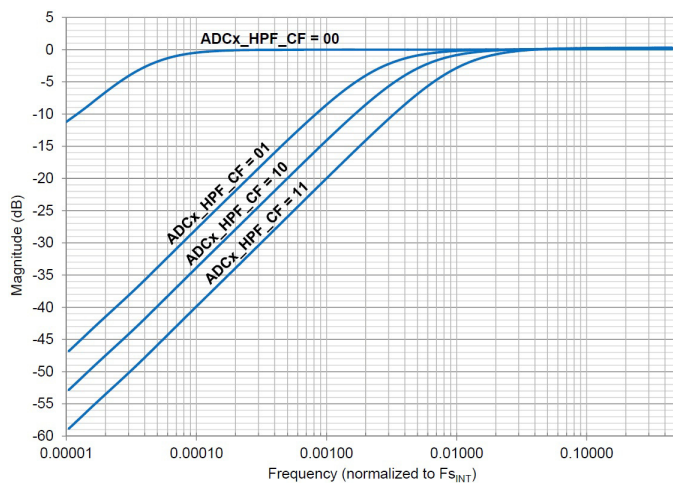

Figure 9-1. ADC HPF Response

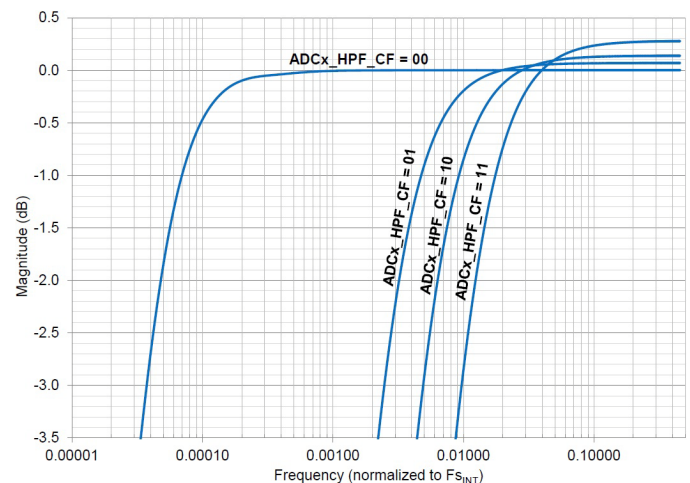
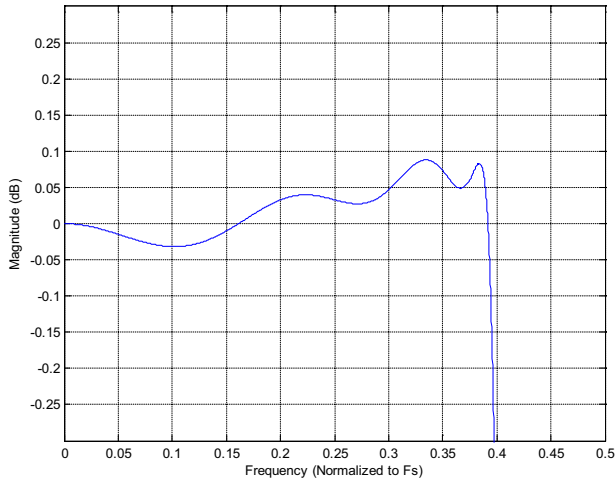
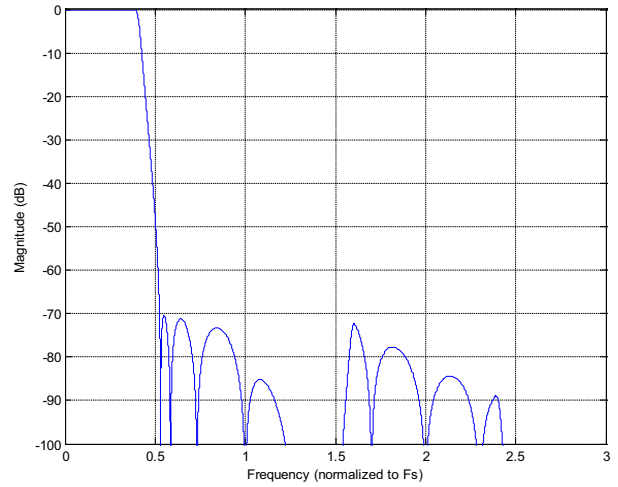
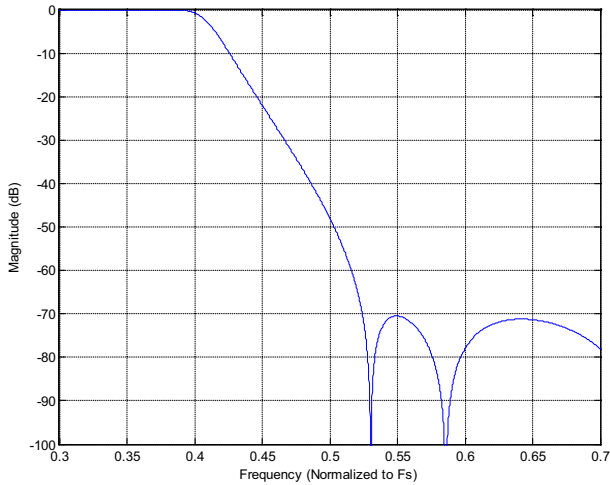
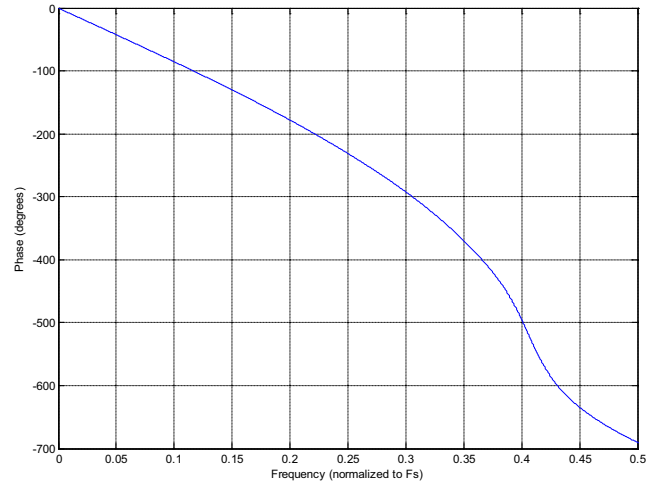
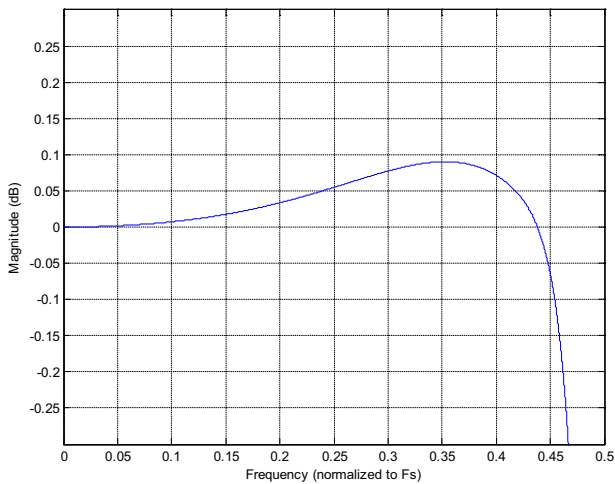
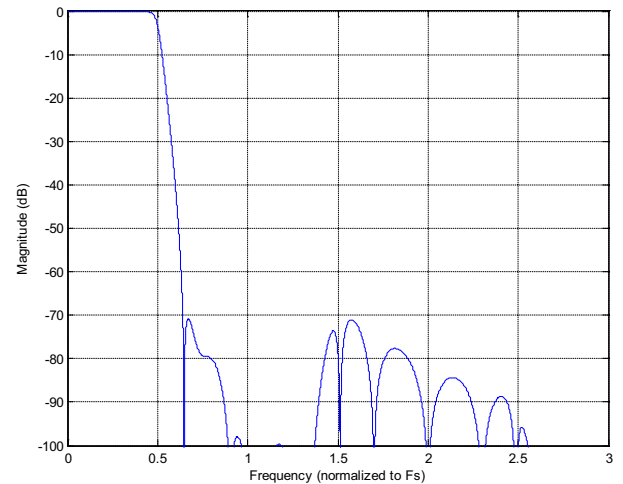
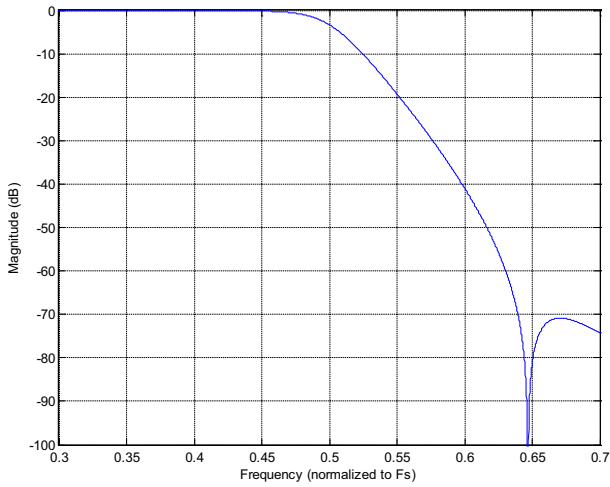
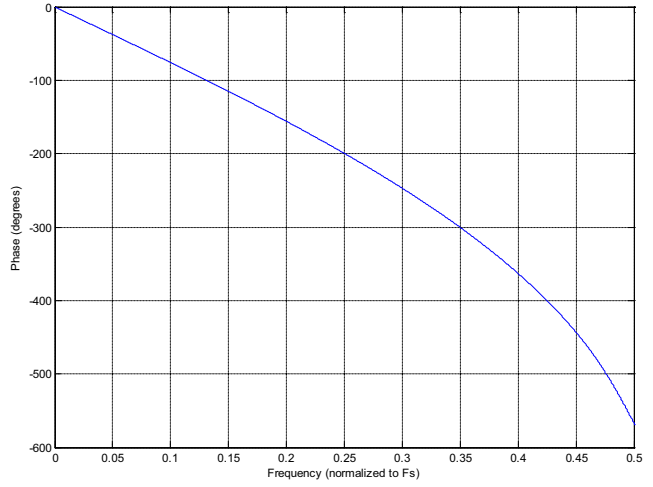
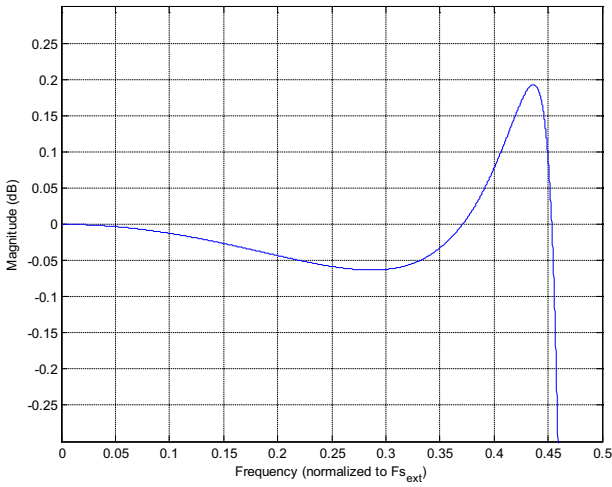
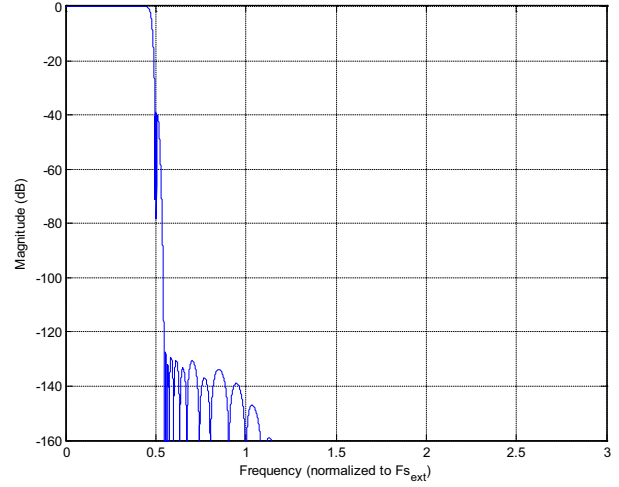
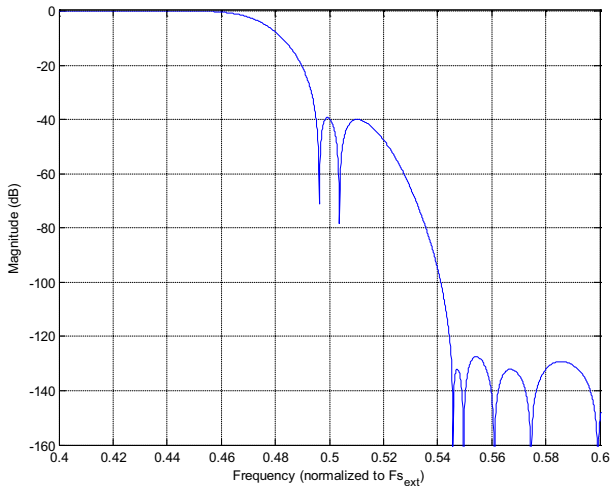
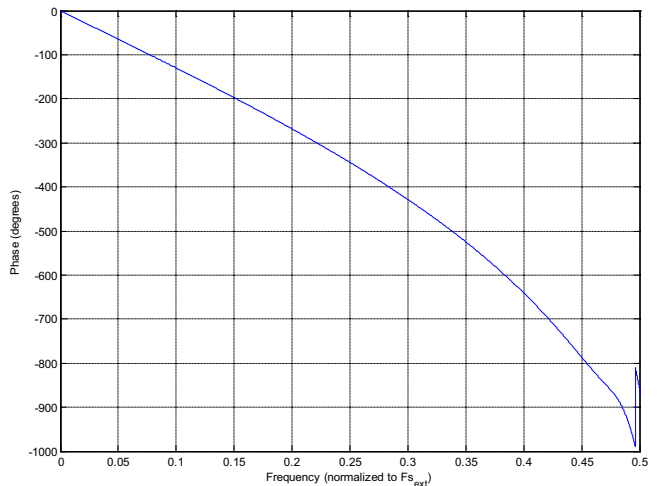
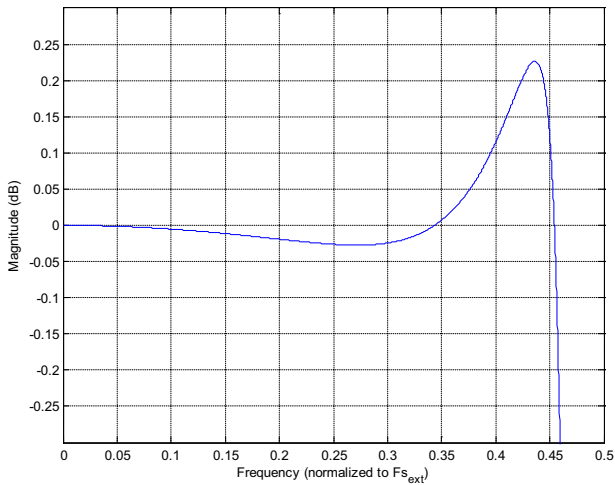
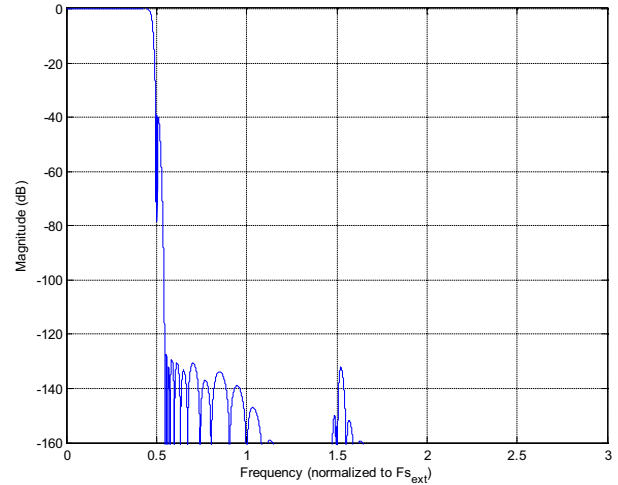
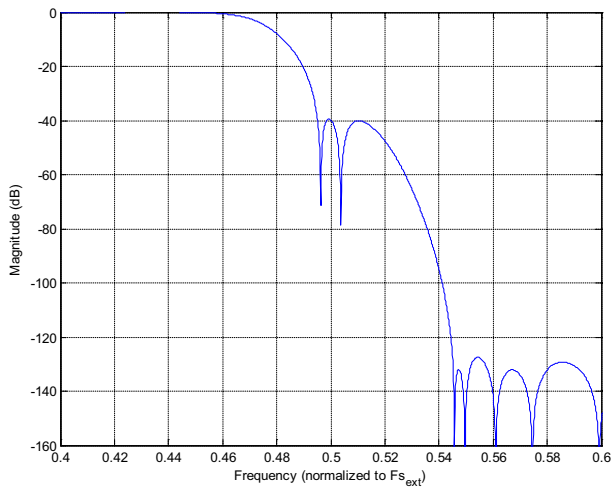
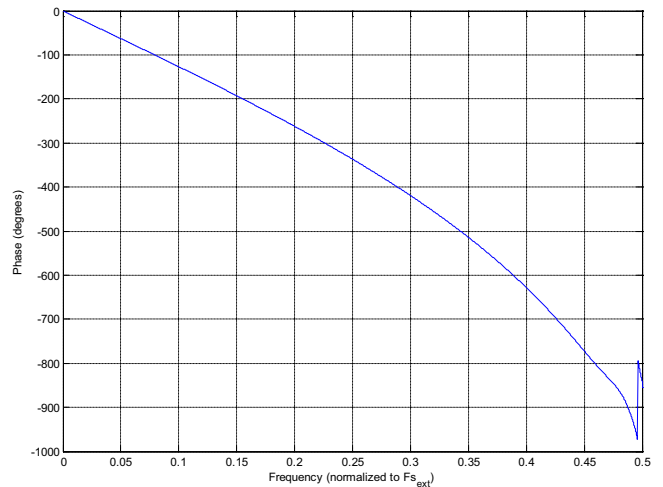

Figure 9-2. ADC HPF Response, Passband Detail

9.1.2 Combined ADC and SRC Response, $F_{s_{ext}} = F_{s_{int}}$

Figure 9-3. Passband—ADCx, Notch Enabled

Figure 9-4. Stopband—ADCx, Notch Enabled

Figure 9-5. Transition Band—ADCx, Notch Enabled

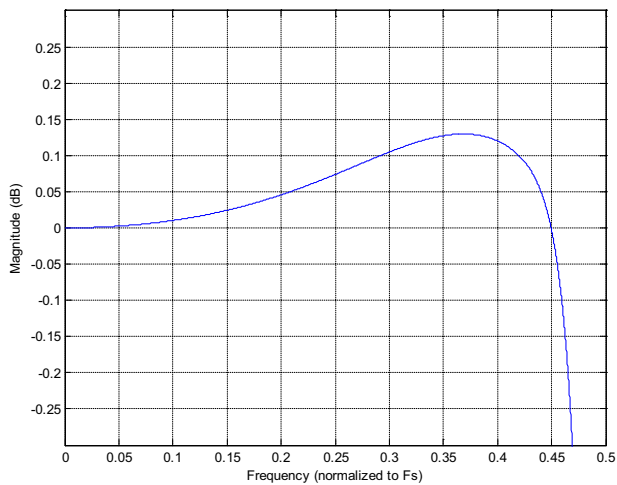
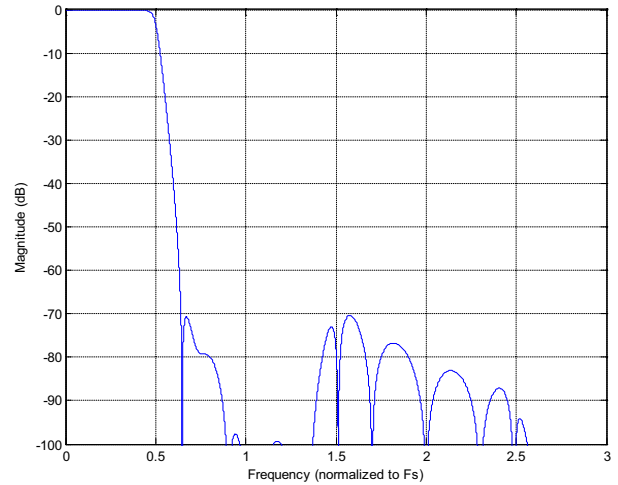
Figure 9-6. Phase Response—ADCx, Notch Enabled

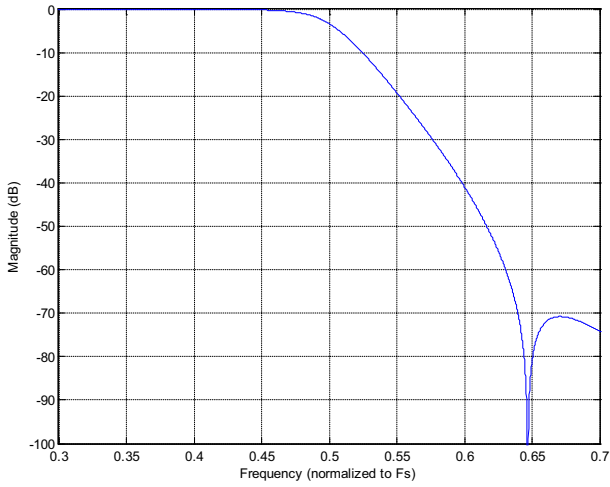
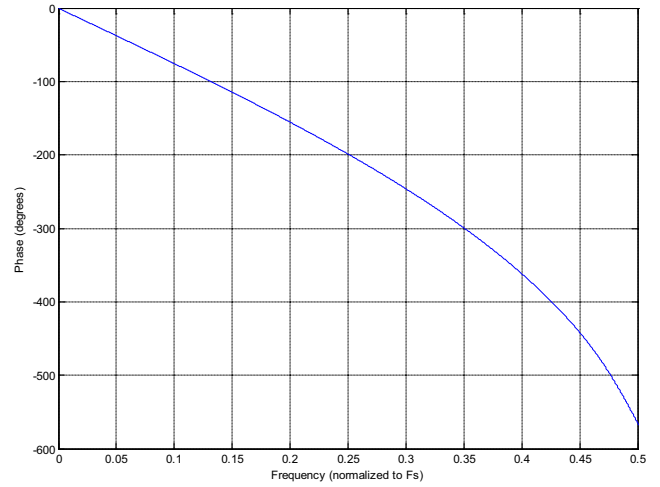
Figure 9-7. Passband—ADCx, Notch Disabled

Figure 9-8. Stopband—ADCx, Notch Disabled

Figure 9-9. Transition Band—ADCx, Notch Disabled

Figure 9-10. Phase Response—ADCx, Notch Disabled
9.1.3 Combined ADC and SRC Response, $F_{s_{ext}} = 50$ kHz, $F_{s_{int}} = 16$ kHz, $MCLK = 19.2$ MHz

Figure 9-11. Passband—ADCx, Notch Enabled

Figure 9-12. Stopband—ADCx, Notch Enabled

Figure 9-13. Transition Band—ADCx, Notch Enabled

Figure 9-14. Phase Response—ADCx, Notch Enabled

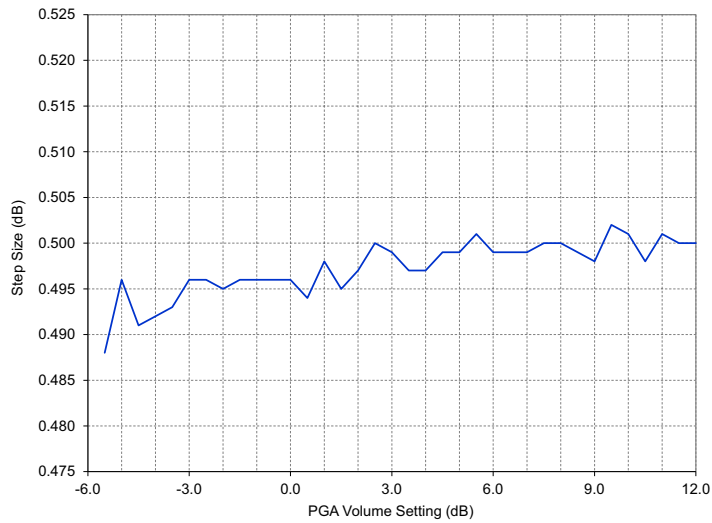
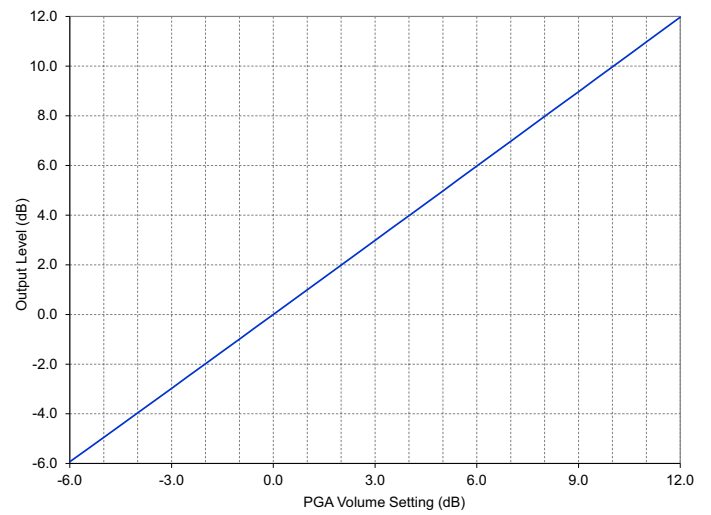

Figure 9-15. Passband—ADCx, Notch Disabled

Figure 9-16. Stopband—ADCx, Notch Disabled

Figure 9-17. Transition Band—ADCx, Notch Disabled

Figure 9-18. Phase Response—ADCx, Notch Disabled

9.1.4 Combined DMIC and SRC Response, $F_{s_{ext}} = F_{s_{int}}$

Figure 9-19. Passband—DMICx, Notch Disabled

Figure 9-20. Stopband—DMICx, Notch Disabled

Figure 9-21. Transition Band—DMICx, Notch Disabled

Figure 9-22. Phase Response—DMICx, Notch Disabled

9.2 PGA Gain Linearity

Figure 9-23. PGA DNL

Figure 9-24. PGA INL

9.3 Dynamic Range Versus Sampling Frequency

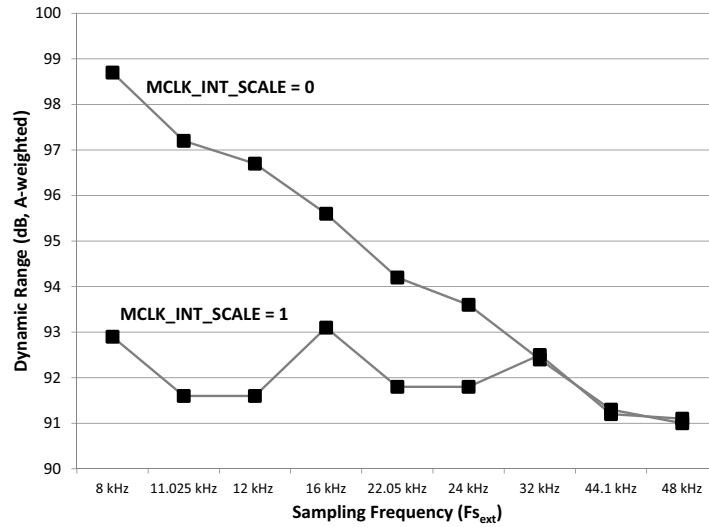
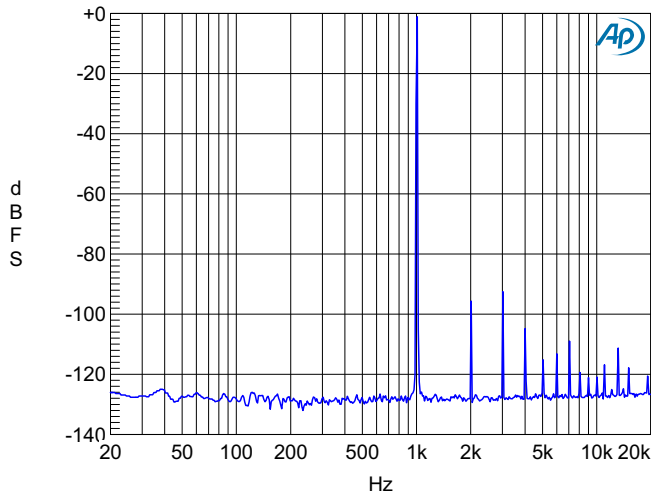
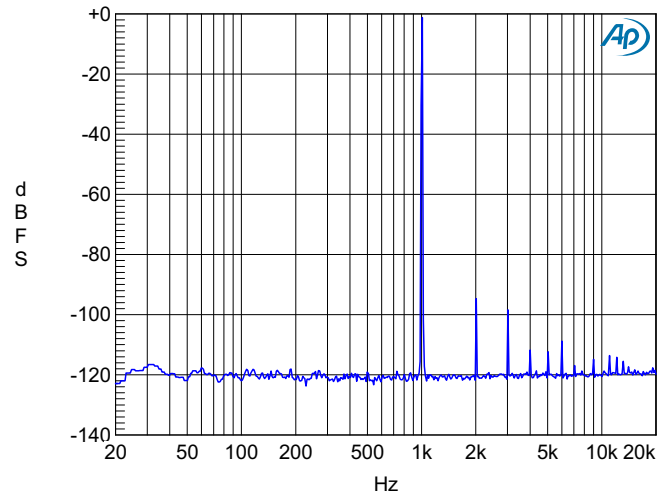

Figure 9-25. Dynamic Range Versus Sampling Frequency

9.4 FFTs



**Figure 9-26. FFT, 1 kHz, -1 dBFS, Preamp Setting: 0 dB
PGA Setting: 0 dB, Fs_{int} = Fs_{ext} = 48 kHz**



**Figure 9-27. FFT, 1 kHz, -1 dBFS, Preamp Setting: 0 dB,
PGA Setting: +12 dB, Fs_{int} = Fs_{ext} = 48 kHz**

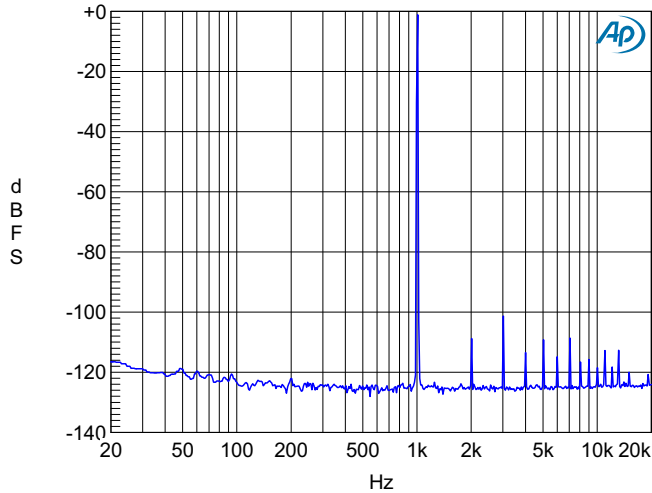

Figure 9-28. FFT, 1 kHz, -1 dBFS, Preamp Setting: +10 dB, PGA Setting: 0 dB, $F_{s_{int}} = F_{s_{ext}} = 48$ kHz

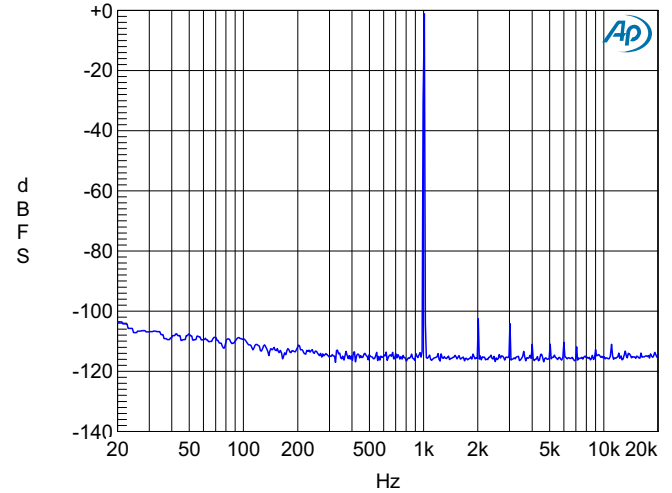

Figure 9-29. FFT, 1 kHz, -1 dBFS, Preamp Setting: +10 dB, PGA Setting: +12 dB, $F_{s_{int}} = F_{s_{ext}} = 48$ kHz

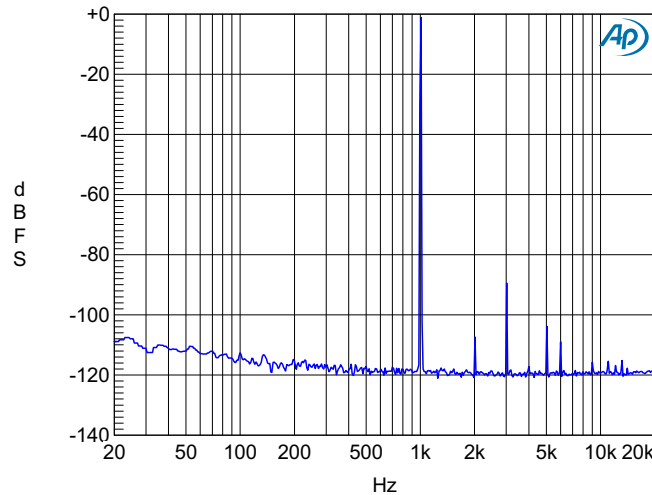

Figure 9-30. FFT, 1 kHz, -1 dBFS, Preamp Setting: +20 dB, PGA Setting: 0 dB, $F_{s_{int}} = F_{s_{ext}} = 48$ kHz

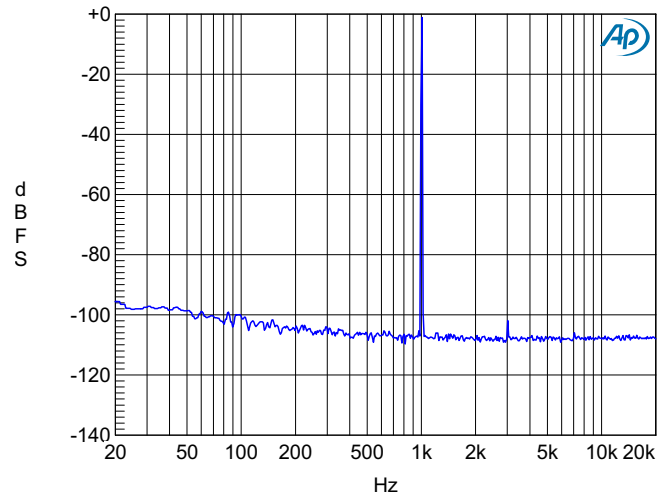

Figure 9-31. FFT, 1 kHz, -1 dBFS, Preamp Setting: +20 dB, PGA Setting: +12 dB, $F_{s_{int}} = F_{s_{ext}} = 48$ kHz

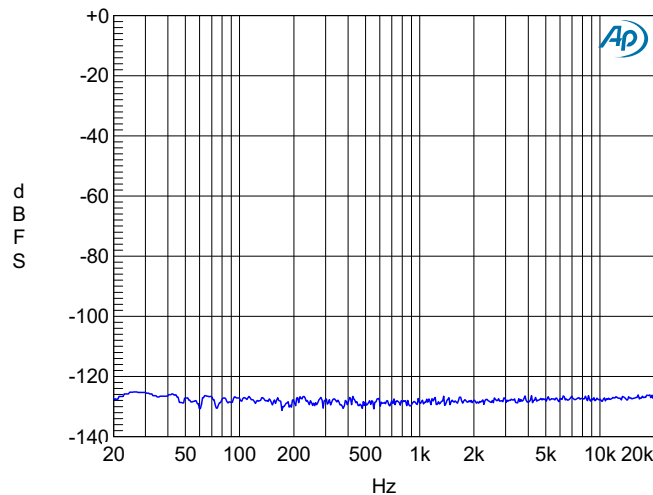
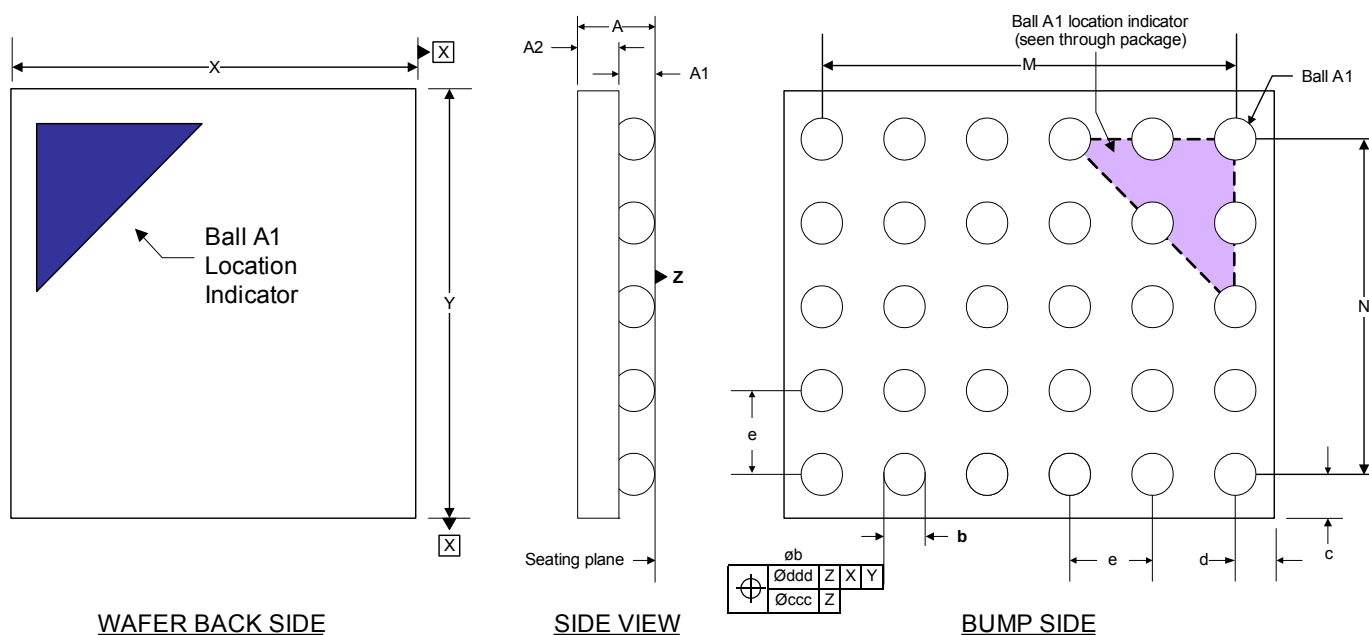

Figure 9-32. FFT, No Input, Preamp Setting: 0 dB, PGA Setting: 0 dB, $F_{s_{int}} = F_{s_{ext}} = 48$ kHz

10 Package Dimensions

10.1 WLCSP Package

Notes:

- Dimensioning and tolerances per ASME Y 14.5M–1994.
- The Ball A1 position indicator is for illustration purposes only and may not be to scale.
- Dimension “b” applies to the solder sphere diameter and is measured at the midpoint between the package body and the seating plane datum Z.

Figure 10-1. 30-Ball WLCSP Package Drawing
Table 10-1. WLCSP Package Dimensions

Dim	Dimensions (Millimeters)		
	Min	Nom	Max
A	0.450	0.505	0.560
A1	0.170	0.200	0.230
A2	0.280	0.305	0.330
M	BSC	2.000	BSC
N	BSC	1.600	BSC
b	0.230	0.260	0.290
c	REF	0.306	REF
d	REF	0.306	REF
e	BSC	0.400	BSC
X	2.593	2.613	2.633
Y	2.193	2.213	2.233

ccc = 0.05

ddd = 0.15

10.2 QFN Package

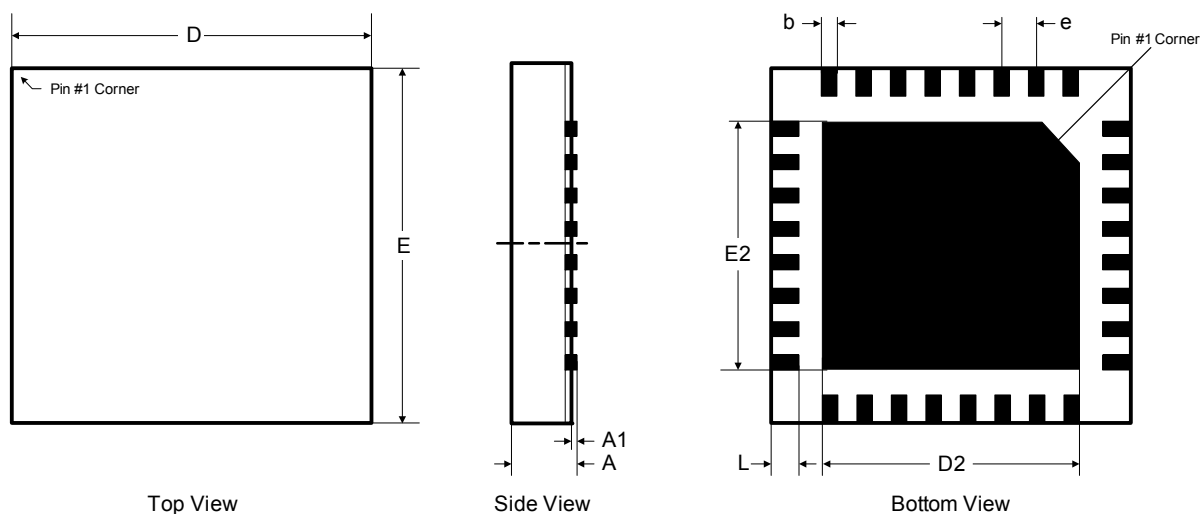

Figure 10-2. 32-Pin QFN Package Drawing ¹

Dim	Millimeters		
	Min	Nom	Max
A	—	—	1.00
A1	0.00	—	0.05
b	0.20	0.25	0.30
D	5.00 BSC		
D2	3.55	3.65	3.75
E	5.00 BSC		
E2	3.55	3.65	3.75
e	0.50 BSC		
L	0.35	0.40	0.45

JEDEC #: MO-220

Controlling dimension is millimeters.

1. Dimensioning and tolerances per ASME Y 14.5M–1995.
2. Dimensioning lead width applies to the plated terminal and is measured between 0.20 and 0.25 mm from the terminal tip.

11 Thermal Characteristics

Table 11-1. Thermal Characteristics

Parameters ^{1,2}		Symbol	Min	Typ	Max	Units
Junction-to-ambient thermal impedance	WLCSP	θ_{JA}	—	61	—	°C/W
	QFN		—	28	—	°C/W
Junction-to-printed circuit board thermal impedance	WLCSP	θ_{JB}	—	10	—	°C/W
	QFN		—	15	—	°C/W

1. Test printed circuit board assembly (PCBA) constructed in accordance with JEDEC standard JESD51–9. Two-signal, two-plane (2s2p) PCB used.
2. Test conducted with still air on a four-layer board in accordance with JEDEC standards, JESD51, JESD51–2A, and JESD51–8.

12 Ordering Information

Table 12-1. Ordering Information

Product	Description	Package	Pb Free	Grade	Temp Range	Container	Order #
CS53L30	Low-Power Quad-Channel Microphone ADC with TDM Output	30-ball WLCSP	Yes	Commercial	–10°C to +70°C	Tape and reel	CS53L30-CWZR
		32-pin QFN	Yes	Commercial	–10°C to +70°C	Tape and reel	CS53L30-CNZR
						Tray	CS53L30-CNZ

13 Revision History

Revision	Change
F1 MAY '13	<ul style="list-style-type: none"> • Provided specific range of audio sample rates in System Features section on p. 1. • Added Note 6 to Fig. 2-1 and Fig. 2-2. • Added reference to Section 5.7 in Note 8 in Fig. 2-2. • Updated mic bias startup delay specification in Table 3-6. • Added power consumption register field settings in Table 3-9. • Updated maximum SCLK duty cycle specification for I2S master mode in Table 3-11. • Updated min and max specifications for t_{HOLD2} when <code>SHIFT_LEFT = 1</code> in Table 3-12. • Updated figure in Note 8 in Table 3-12. • Clarified that <code>ADC1x_PDN</code> and <code>ADC2x_PDN</code> bits must be set when input channel type is digital in Section 7.23 and Section 7.29. • Reformatted presentation of WLCSP package dimensions in Section 10.1.
F2 MAR '15	<ul style="list-style-type: none"> • Updated Table 12-1 "Ordering Information" to reflect "Tray" for QFN package bulk delivery option, order number CS53L30-CNZ. • Updated legal text.

Contacting Cirrus Logic Support

For all product questions and inquiries, contact a Cirrus Logic Sales Representative.

To find one nearest you, go to www.cirrus.com.

IMPORTANT NOTICE

The products and services of Cirrus Logic International (UK) Limited; Cirrus Logic, Inc.; and other companies in the Cirrus Logic group (collectively either "Cirrus" or "Cirrus Logic") are sold subject to Cirrus's terms and conditions of sale supplied at the time of order acknowledgment, including those pertaining to warranty, indemnification, and limitation of liability. Software is provided pursuant to applicable license terms. Cirrus reserves the right to make changes to its products and specifications or to discontinue any product or service without notice. Customers should therefore obtain the latest version of relevant information from Cirrus to verify that the information is current and complete. Testing and other quality control techniques are utilized to the extent Cirrus deems necessary. Specific testing of all parameters of each device is not necessarily performed. In order to minimize risks associated with customer applications, the customer must use adequate design and operating safeguards to minimize inherent or procedural hazards. Cirrus is not liable for applications assistance or customer product design. The customer is solely responsible for its selection and use of Cirrus products.

CERTAIN APPLICATIONS USING SEMICONDUCTOR PRODUCTS MAY INVOLVE POTENTIAL RISKS OF DEATH, PERSONAL INJURY, OR SEVERE PROPERTY OR ENVIRONMENTAL DAMAGE ("CRITICAL APPLICATIONS"). CIRRUS PRODUCTS ARE NOT DESIGNED, AUTHORIZED OR WARRANTED FOR USE IN PRODUCTS SURGICALLY IMPLANTED INTO THE BODY, AUTOMOTIVE SAFETY OR SECURITY DEVICES, NUCLEAR SYSTEMS, LIFE SUPPORT PRODUCTS OR OTHER CRITICAL APPLICATIONS. INCLUSION OF CIRRUS PRODUCTS IN SUCH APPLICATIONS IS UNDERSTOOD TO BE FULLY AT THE CUSTOMER'S RISK AND CIRRUS DISCLAIMS AND MAKES NO WARRANTY, EXPRESS, STATUTORY OR IMPLIED, INCLUDING THE IMPLIED WARRANTIES OF MERCHANTABILITY AND FITNESS FOR PARTICULAR PURPOSE, WITH REGARD TO ANY CIRRUS PRODUCT THAT IS USED IN SUCH A MANNER. IF THE CUSTOMER OR CUSTOMER'S CUSTOMER USES OR PERMITS THE USE OF CIRRUS PRODUCTS IN CRITICAL APPLICATIONS, CUSTOMER AGREES, BY SUCH USE, TO FULLY INDEMNIFY CIRRUS, ITS OFFICERS, DIRECTORS, EMPLOYEES, DISTRIBUTORS AND OTHER AGENTS FROM ANY AND ALL LIABILITY, INCLUDING ATTORNEYS' FEES AND COSTS, THAT MAY RESULT FROM OR ARISE IN CONNECTION WITH THESE USES.

This document is the property of Cirrus and by furnishing this information, Cirrus grants no license, express or implied, under any patents, mask work rights, copyrights, trademarks, trade secrets or other intellectual property rights. Any provision or publication of any third party's products or services does not constitute Cirrus's approval, license, warranty or endorsement thereof. Cirrus gives consent for copies to be made of the information contained herein only for use within your organization with respect to Cirrus integrated circuits or other products of Cirrus, and only if the reproduction is without alteration and is accompanied by all associated copyright, proprietary and other notices and conditions (including this notice). This consent does not extend to other copying such as copying for general distribution, advertising or promotional purposes, or for creating any work for resale. This document and its information is provided "AS IS" without warranty of any kind (express or implied). All statutory warranties and conditions are excluded to the fullest extent possible. No responsibility is assumed by Cirrus for the use of information herein, including use of this information as the basis for manufacture or sale of any items, or for infringement of patents or other rights of third parties. Cirrus Logic, Cirrus, the Cirrus Logic logo design and SoundClear are among the trademarks of Cirrus. Other brand and product names may be trademarks or service marks of their respective owners.

Copyright © 2013–2015 Cirrus Logic, Inc. All rights reserved.

Bluetooth is a trademark of Bluetooth SIG, Inc.

Looking for pricing, stock, or lifecycle information?

Click below to explore more details on WIN SOURCE:

 [View CS53L30-CWZR on WIN SOURCE](#)

 [Cirrus Logic Inc. Information](#)

Optimize Your Supply Chain with WIN SOURCE Solutions

-  Global Sourcing Solution
-  Obsolete Management
-  Cost Control Management
-  Shortage Management
-  Alternative Solution
-  Excess Inventory Management