



**THE DATASHEET OF
NCV57080ADR2G**



Thank you for your interest in **onsemi** products.
Your technical document begins on the following pages.



Your Feedback is Important to Us!

Please take a moment to participate in our short survey.
At **onsemi**, we are dedicated to delivering technical content that best meets your needs.

[Help Us Improve – Take the Survey](#)

This survey is intended to collect your feedback, capture any issues you may encounter, and to provide improvements you would like to suggest.

We look forward to your feedback.

To learn more about **onsemi**, please visit our website at
www.onsemi.com

onsemi and **onsemi** and other names, marks, and brands are registered and/or common law trademarks of Semiconductor Components Industries, LLC dba "**onsemi**" or its affiliates and/or subsidiaries in the United States and/or other countries. **onsemi** owns the rights to a number of patents, trademarks, copyrights, trade secrets, and other intellectual property. A listing of **onsemi** product/patent coverage may be accessed at www.onsemi.com/site/pdf/Patent-Marking.pdf. **onsemi** reserves the right to make changes at any time to any products or information herein, without notice. The information herein is provided "as-is" and **onsemi** makes no warranty, representation or guarantee regarding the accuracy of the information, product features, availability, functionality, or suitability of its products for any particular purpose, nor does **onsemi** assume any liability arising out of the application or use of any product or circuit, and specifically disclaims any and all liability, including without limitation special, consequential or incidental damages. Buyer is responsible for its products and applications using **onsemi** products, including compliance with all laws, regulations and safety requirements or standards, regardless of any support or applications information provided by **onsemi**. "Typical" parameters which may be provided in **onsemi** data sheets and/or specifications can and do vary in different applications and actual performance may vary over time. All operating parameters, including "Typicals" must be validated for each customer application by customer's technical experts. **onsemi** does not convey any license under any of its intellectual property rights nor the rights of others. **onsemi** products are not designed, intended, or authorized for use as a critical component in life support systems or any FDA Class 3 medical devices or medical devices with a same or similar classification in a foreign jurisdiction or any devices intended for implantation in the human body. Should Buyer purchase or use **onsemi** products for any such unintended or unauthorized application, Buyer shall indemnify and hold **onsemi** and its officers, employees, subsidiaries, affiliates, and distributors harmless against all claims, costs, damages, and expenses, and reasonable attorney fees arising out of, directly or indirectly, any claim of personal injury or death associated with such unintended or unauthorized use, even if such claim alleges that **onsemi** was negligent regarding the design or manufacture of the part. **onsemi** is an Equal Opportunity/Affirmative Action Employer. This literature is subject to all applicable copyright laws and is not for resale in any manner. Other names and brands may be claimed as the property of others.

Isolated High Current IGBT/MOSFET Gate Driver



SOIC-8 NB
CASE 751-07

NCx57080y, NCx57081y

(x = D or V, y = A, B or C)

NCx57080y, NCx57081y are high-current single channel IGBT/MOSFET gate drivers with 3.75 kVrms internal galvanic isolation, designed for high system efficiency and reliability in high power applications. The devices accept complementary inputs and depending on the pin configuration, offer options such as Active Miller Clamp (version A), negative power supply (version B) and separate high and low (OUTH and OUTL) driver outputs (version C) for system design convenience. The driver accommodate wide range of input bias voltage and signal levels from 3.3 V to 20 V and they are available in narrow-body SOIC-8 package.

Features

- High Peak Output Current (+6.5 A/-6.5 A)
- Low Clamp Voltage Drop Eliminates the Need of Negative Power Supply to Prevent Spurious Gate Turn-on (Version A)
- Short Propagation Delays with Accurate Matching
- IGBT/MOSFET Gate Clamping during Short Circuit
- IGBT/MOSFET Gate Active Pull Down
- Tight UVLO Thresholds for Bias Flexibility
- Wide Bias Voltage Range including Negative V_{EE2} (Version B)
- 3.3 V, 5 V, and 15 V Logic Input
- 3.75 kV_{RMS} V_{ISO} (I-O) (to meet UL1577 Requirements)
- Safety and Regulatory Approvals:
 - ♦ UL1577 Certified, 3750 VAC_{RMS} for 1 Minute
 - ♦ DIN VDE V 0884-11 Certification Pending, 870 V_{PK} Working Insulation Voltage
- High Transient Immunity
- High Electromagnetic Immunity
- NCV Prefix for Automotive and Other Applications Requiring Unique Site and Control Change Requirements; AEC-Q100 Qualified and PPAP Capable
- These Devices are Pb-Free, Halogen Free/BFR Free and are RoHS Compliant

Typical Applications

- Motor Control
- Uninterruptible Power Supplies (UPS)
- Automotive Applications
- Industrial Power Supplies
- Solar Inverters
- HVAC

MARKING DIAGRAM

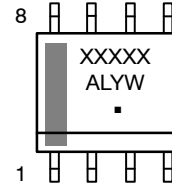

- XXXXX = Specific Device Code
 XXXX = NCx57080y, 57081y
 x = D or V
 y = A/B/C
 A = Assembly Location
 L = Wafer Lot
 Y = Year
 W = Work Week
 ■ = Pb-Free Package

PIN CONNECTIONS

See detailed pin connection information on page 2 of this data sheet.

ORDERING INFORMATION

See detailed ordering and shipping information on page 21 of this data sheet.

NCx57080y, NCx57081y

PIN CONNECTIONS



NCx57080A, NCx57081A

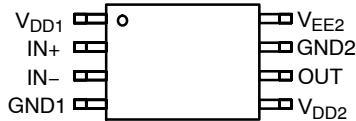

NCx57080B, NCx57081B

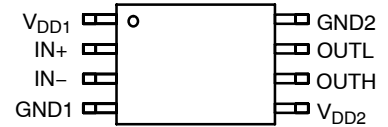

NCx57080C, NCx57081C

NOTE: x = D or V

Figure 1. Pin Connections

BLOCK DIAGRAM AND APPLICATION SCHEMATIC - NCx5708zA

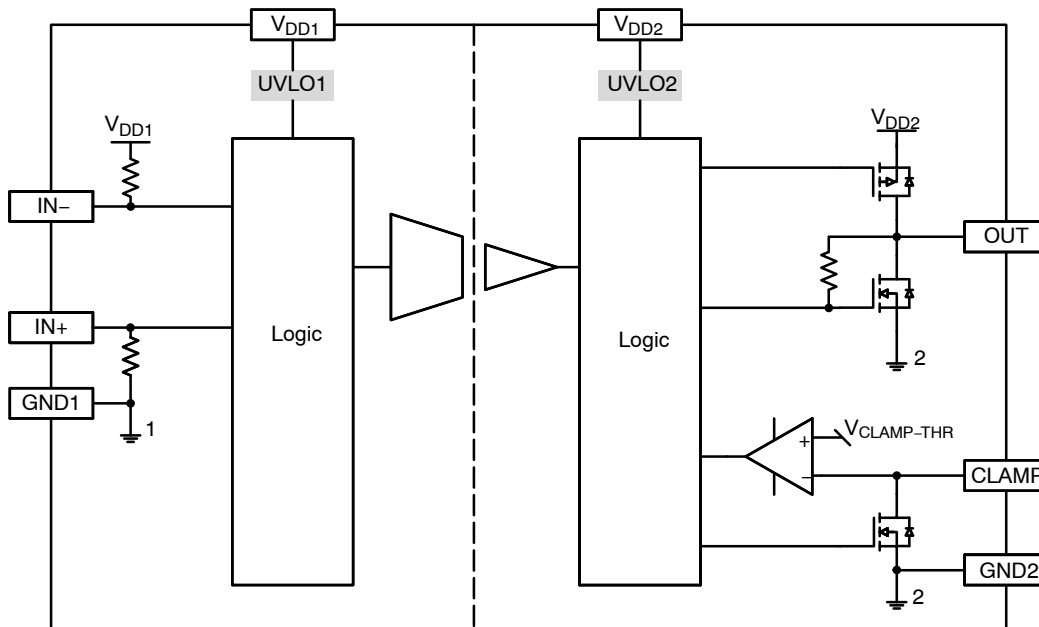

Figure 2. Simplified Block Diagram, NCx5708zA

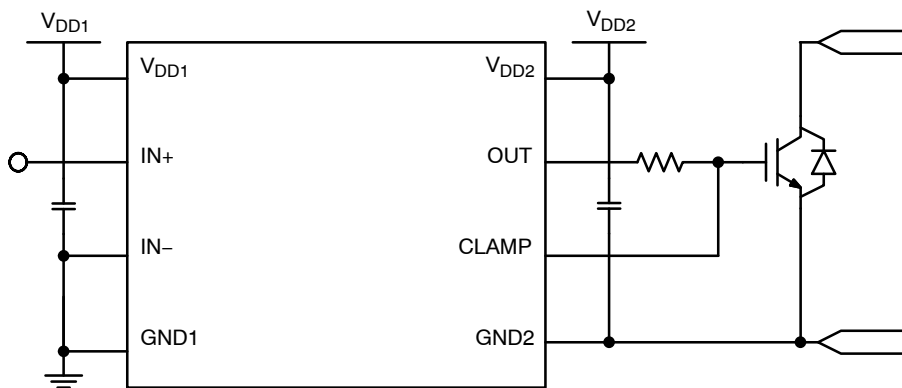

Figure 3. Simplified Application Schematics, NCx5708zA

NCx57080y, NCx57081y

BLOCK DIAGRAM AND APPLICATION SCHEMATIC – NCx5708zB

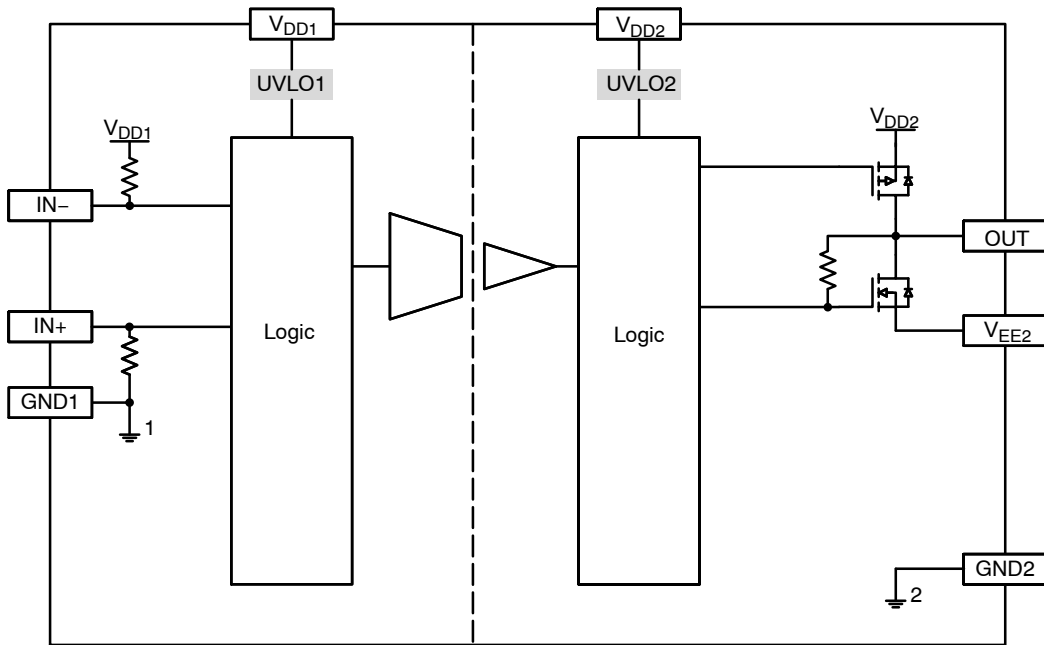

Figure 4. Simplified Block Diagram, NCx5708zB

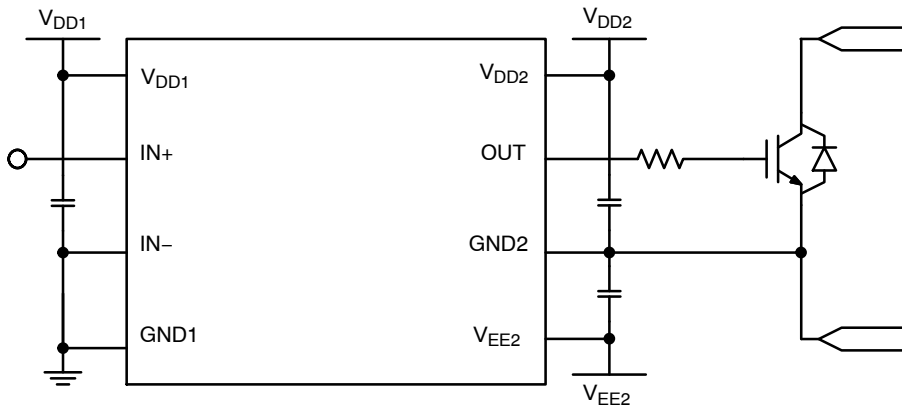

Figure 5. Simplified Application Schematics, NCx5708zB

NCx57080y, NCx57081y

BLOCK DIAGRAM AND APPLICATION SCHEMATIC – NCx5708zC

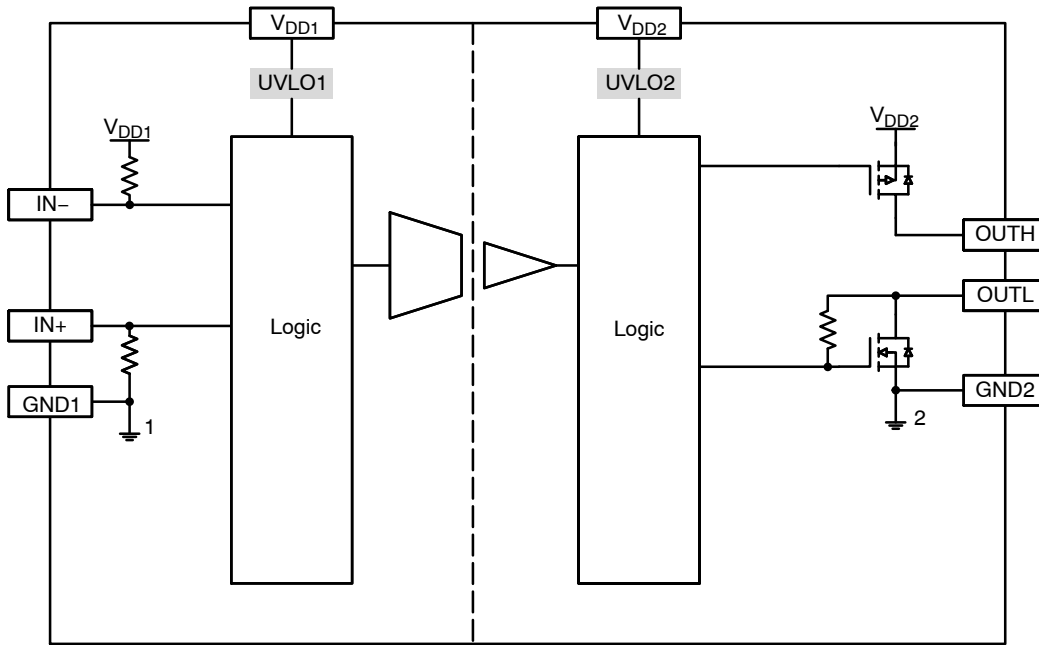

Figure 6. Simplified Block Diagram, NCx5708zC

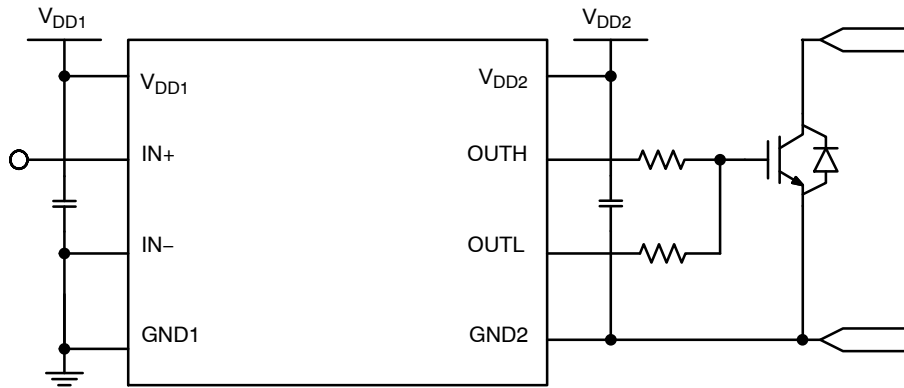

Figure 7. Simplified Application Schematics, NCx5708zC

NCx57080y, NCx57081y

Table 1. FUNCTION DESCRIPTION

| Pin Name | No. | I/O | Description |
|-----------------------------------|-----|-------|---|
| V _{DD1} | 1 | Power | Input side power supply. A good quality bypassing capacitor is required from this pin to GND1 and should be placed close to the pins for best results. The under voltage lockout (UVLO) circuit enables the device to operate at power on when a typical supply voltage higher than V _{UVLO1-OUT-ON} is present. Please see Figures 9A and 9B for more details. |
| IN+ | 2 | I | Non inverted gate driver input. It is internally clamped to GND1 and has an equivalent pull-down resistor of 125 kΩ to ensure that output is low in the absence of an input signal. A minimum positive or negative pulse-width is required at IN+ before OUT or OUTH/OUTL responds. |
| IN- | 3 | I | Inverted gate driver input. It is internally clamped to V _{DD1} and has an equivalent pull-up resistor of 125 kΩ to ensure that output is low in the absence of an input signal. A minimum positive or negative pulse-width is required at IN- before OUT or OUTH/OUTL responds. |
| GND1 | 4 | Power | Input side ground reference. |
| V _{DD2} | 5 | Power | Output side positive power supply. The operating range for this pin is from UVLO2 to its maximum allowed value. A good quality bypassing capacitor is required from this pin to GND2 and should be placed close to the pins for best results. The under voltage lockout (UVLO) circuit enables the device to operate at power on when a typical supply voltage higher than V _{UVLO2-OUT-ON} is present. Please see Figure 9C and 9D for more details. |
| GND2 (NCx5708zA, NCx5708zC) | 8 | Power | Output side gate drive reference connecting to IGBT emitter or MOSFET source. |
| GND2 (NCx5708zB) | 7 | | |
| OUT (NCx5708zA, NCx5708zB) | 6 | O | Driver output that provides the appropriate drive voltage and source/sink current to the IGBT/MOSFET gate. OUT is actively pulled low during start-up. |
| OUTH (NCx5708zC) | 6 | O | Driver high output that provides the appropriate drive voltage and source current to the IGBT/MOSFET gate. |
| OUTL (NCx5708zC) | 7 | O | Driver low output that provides the appropriate drive voltage and sink current to the IGBT/MOSFET gate. OUTL is actively pulled low during start-up. |
| CLAMP (NCx5708zA) | 7 | O | Provides clamping for the IGBT/MOSFET gate during the off period to protect it from parasitic turn-on. Its internal N FET is turned on when the voltage of this pin falls below V _{CLAMP-THR} . It is to be tied directly to IGBT/MOSFET gate with minimum trace length for best results. |
| V _{EE2} (NCx5708zB) | 8 | Power | Output side negative power supply. A good quality bypassing capacitor is required from this pin to GND2 and should be placed close to the pins for best results. |

NOTE: (x = D or V, z = 0 or 1)

NCx57080y, NCx57081y

Table 2. SAFETY AND INSULATION RATINGS

| Symbol | Parameter | Value | Unit |
|-----------------------|---|-------------------------|------------------|
| | Installation Classifications per DIN VDE 0110/1.89 Table 1 Rated Mains Voltage | < 150 V _{RMS} | I – IV |
| | | < 300 V _{RMS} | I – IV |
| | | < 450 V _{RMS} | I – IV |
| | | < 600 V _{RMS} | I – IV |
| | | < 1000 V _{RMS} | I – III |
| CTI | Comparative Tracking Index (DIN IEC 112/VDE 0303 Part 1) | 600 | |
| | Climatic Classification | 40/125/21 | |
| | Pollution Degree (DIN VDE 0110/1.89) | 2 | |
| V _{PR} | Input-to-Output Test Voltage, Method b, $V_{IORM} \times 1.875 = V_{PR}$, 100% Production Test with $t_m = 1$ s, Partial Discharge < 5 pC | 2250 | V _{pk} |
| V _{IORM} | Maximum Repetitive Peak Voltage | 1200 | V _{pk} |
| V _{IOWM} | Maximum Working Voltage | 870 | V _{RMS} |
| V _{IOTM} | Highest Allowable Over Voltage | 6300 | V _{pk} |
| E _{CR} | External Creepage | 4.0 | mm |
| E _{CL} | External Clearance | 4.0 | mm |
| DTI | Insulation Thickness | 17.3 | μm |
| T _{Case} | Safety Limit Values – Maximum Values in Failure; Case Temperature | 150 | °C |
| P _{S,INPUT} | Safety Limit Values – Maximum Values in Failure; Input Power | 121 | mW |
| P _{S,OUTPUT} | Safety Limit Values – Maximum Values in Failure; Output Power | 1194 | mW |
| R _{IO} | Insulation Resistance at TS, V _{IO} = 500 V | 10 ⁹ | Ω |

Table 3. ABSOLUTE MAXIMUM RATINGS (Note 1)

Over operating free-air temperature range unless otherwise noted.

| Symbol | Parameter | Minimum | Maximum | Unit |
|--|---|-----------|-----------------------------|------|
| V _{DD1} -GND1 | Supply Voltage, Input Side | -0.3 | 22 | V |
| V _{DD2} -GND2 | Positive Power Supply, Output Side | -0.3 | 32 | V |
| V _{EE2} -GND2 | Negative Power Supply, Output Side | -18 | 0.3 | V |
| V _{DD2} -V _{EE2} (V _{MAX2}) | Differential Power Supply, Output Side (NCx5708zB) | 0 | 36 | V |
| V _{OUT} -GND2 V _{OUTH} -GND2 | Gate-driver Output High Voltage NCx5708zA/B NCx5708zC | - | V _{DD2} + 0.3 - | V |
| V _{OUT} -GND2 V _{OUTL} -GND2 | Gate-driver Output Low Voltage NCx5708zA/B NCx5708zC | -0.3 - | - - | V |
| I _{PK} -SRC | Gate-driver Output Sourcing Current (maximum pulse width = 10 μs, maximum duty cycle = 0.2%, V _{DD2} = 15 V, V _{EE2} = 0 V) | - | 6.5 | A |
| I _{PK} -SNK | Gate-driver Output Sinking Current (maximum pulse width = 10 μs, maximum duty cycle = 0.2%, V _{DD2} = 15 V, V _{EE2} = 0 V) | - | 6.5 | A |
| I _{PK} -CLAMP | Clamp Sinking Current (maximum pulse width = 10 μs, maximum duty cycle = 0.2%, V _{CLAMP} = 2.5 V) | - | 2.5 | A |
| t _{CLP} | Maximum Short Circuit Clamping Time (I _{OUT_CLAMP} = 500 mA) | - | 10 | μs |
| V _{LIM} -GND1 | Voltage at IN+, IN- | -0.3 | V _{DD1} + 0.3 | V |
| V _{CLAMP} -GND2 | Clamp Voltage | -0.3 | V _{DD2} + 0.3 | V |
| P _D | Power Dissipation (SOIC-8 Narrow Package) | - | 1315 | mW |

NCx57080y, NCx57081y

Table 3. ABSOLUTE MAXIMUM RATINGS (Note 1) (continued)

Over operating free-air temperature range unless otherwise noted.

| Symbol | Parameter | Minimum | Maximum | Unit |
|----------------------|---|---------|---------|------|
| T _J (max) | Maximum Junction Temperature | -40 | 150 | °C |
| T _{STG} | Storage Temperature Range | -65 | 150 | °C |
| ESDHBM | ESD Capability, Human Body Model (Note 2) | - | ±2 | kV |
| ESDCDM | ESD Capability, Charged Device Model (Note 2) | - | ±2 | kV |
| MSL | Moisture Sensitivity Level | - | 1 | - |
| T _{SLD} | Lead Temperature Soldering Reflow, Pb-Free (Note 3) | - | 260 | °C |

Stresses exceeding those listed in the Maximum Ratings table may damage the device. If any of these limits are exceeded, device functionality should not be assumed, damage may occur and reliability may be affected.

1. Refer to ELECTRICAL CHARACTERISTICS and APPLICATION INFORMATION for Safe Operating Area.
2. This device series incorporates ESD protection and is tested by the following methods:
 ESD Human Body Model tested per AEC-Q100-002 (EIA/JESD22-A114).
 ESD Charged Device Model tested per AEC-Q100-011 (EIA/JESD22-C101).
 Latchup Current Maximum Rating: ≤ 100 mA per JEDEC standard:
 JESD78, 25°C (absolute maximum ratings for all tests)
 JESD78, 125°C (limitation for IN+ test, V_{DD1} = IN+ = 12 V maximum)
3. For information, please refer to our Soldering and Mounting Techniques Reference Manual, SOLDERRM/D.

Table 4. THERMAL CHARACTERISTICS

| Symbol | Parameter | Value | Unit |
|------------------|--|-------------------------------|------|
| R _{θJA} | Thermal Characteristics, SOIC-8 narrow body (Note 4) Thermal Resistance, Junction-to-Air (Note 5) | 95 (4-Layer) 175 (1-Layer) | °C/W |

4. Refer to ELECTRICAL CHARACTERISTICS and APPLICATION INFORMATION for Safe Operating Area.
5. Values based on copper area of 100 mm² (or 0.16 in²) of 1 oz copper thickness and FR4 PCB substrate.

Table 5. OPERATING RANGES (Note 6)

| Symbol | Parameter | Min | Max | Unit |
|---|--|------------------------|------------------------|-------|
| V _{DD1} -GND1 | Supply Voltage, Input Side | UVLO1 | 20 | V |
| V _{DD2} -GND2 | Positive Power Supply, Output Side | UVLO2 | 30 | V |
| V _{EE2} -GND2 | Negative Power Supply, Output Side (NCx5708zB) | -15 | 0 | V |
| V _{DD2} -V _{EE2} (V _{MAX2}) | Differential Power Supply, Output Side (NCx5708zB) | 0 | 32 | V |
| V _{IL} | Low Level Input Voltage at IN+, IN- (Note 7) | 0 | 0.3 × V _{DD1} | V |
| V _{IH} | High Level Input Voltage at IN+, IN- (Note 7) | 0.7 × V _{DD1} | V _{DD1} | V |
| dV _{ISO} /dt | Common Mode Transient Immunity (Note 8) | 100 | - | kV/μs |
| T _A | Ambient Temperature | -40 | 125 | °C |

Functional operation above the stresses listed in the Recommended Operating Ranges is not implied. Extended exposure to stresses beyond the Recommended Operating Ranges limits may affect device reliability.

6. Refer to ELECTRICAL CHARACTERISTICS and APPLICATION INFORMATION for Safe Operating Area.
7. Table values are valid for 3.3 V and 5 V V_{DD1}, for higher V_{DD1} voltages, the threshold values are maintained at the 5 V V_{DD1} levels.
8. Was tested by ±1500 V pulses up to 100 kV/μs.

Table 6. ISOLATION CHARACTERISTICS

| Symbol | Parameter | Conditions | Value | Unit |
|--------------------------------|--------------------------------|--|------------------|------------------|
| V _{ISO, input-output} | Input-Output Isolation Voltage | T _A = 25°C, Relative Humidity < 50%, t = 1.0 minute, I _{L-O} < 30 μA, 50 Hz (Note 9, 10, 11) | 3750 | V _{RMS} |
| R _{ISO} | Isolation Resistance | V _{L-O} = 500 V (Note 9) | 10 ¹¹ | Ω |

9. Device is considered a two-terminal device: pins 1 to 4 are shorted together and pins 5 to 9 are shorted together.
10. 3750 V_{RMS} for 1-minute duration is equivalent to 4500 V_{RMS} for 1-second duration.
11. The input-output isolation voltage is a dielectric voltage rating per UL1577. It should not be regarded as an input-output continuous voltage rating. For the continuous working voltage rating, refer to equipment-level safety specification or DIN VDE V 0884-11 Safety and Insulation Ratings Table.

NCx57080y, NCx57081y

ELECTRICAL CHARACTERISTICS $V_{DD1} = 5\text{ V}$, $V_{DD2} = 15\text{ V}$, ($V_{EE2} = 0\text{ V}$ for NCx5708zB).

For typical values $T_A = 25^\circ\text{C}$, for min/max values, T_A is the operating ambient temperature range that applies, unless otherwise noted.

| Symbol | Parameter | Test Conditions | Min | Typ | Max | Unit |
|-----------------------|--|--|------|------|------|------|
| VOLTAGE SUPPLY | | | | | | |
| $V_{UVLO1-OUT-ON}$ | UVLO1 Output Enabled | | - | - | 3.1 | V |
| $V_{UVLO1-OUT-OFF}$ | UVLO1 Output Disabled | | 2.4 | - | - | V |
| $V_{UVLO1-HYST}$ | UVLO1 Hysteresis | | 0.1 | - | - | V |
| $V_{UVLO2-OUT-ON}$ | UVLO2 Output Enabled | NCx57080y | 12.4 | 12.9 | 13.4 | V |
| | | NCx57081y | 8.6 | 9 | 9.5 | V |
| $V_{UVLO2-OUT-OFF}$ | UVLO2 Output Disabled | NCx57080y | 11.5 | 12 | 12.5 | V |
| | | NCx57081y | 7.6 | 8 | 8.5 | V |
| $V_{UVLO2-HYST}$ | UVLO2 Hysteresis | | 0.7 | 1 | - | V |
| $I_{DD1-0-3.3}$ | Input Supply Quiescent Current | $IN+ = \text{Low}, IN- = \text{Low}, V_{DD1} = 3.3\text{ V}$ | - | - | 2 | mA |
| $I_{DD1-0-5}$ | | $IN+ = \text{Low}, IN- = \text{Low}$ | - | - | 2 | mA |
| $I_{DD1-0-15}$ | | $IN+ = \text{Low}, IN- = \text{Low}, V_{DD1} = 15\text{ V}$ | - | - | 2 | mA |
| $I_{DD1-100-5}$ | | $IN+ = \text{High}, IN- = \text{Low}$ | - | - | 5.5 | mA |
| I_{DD2-0} | Output Positive Supply Quiescent Current | $IN+ = \text{Low}, IN- = \text{Low}, \text{no load}$ | - | - | 2 | mA |
| $I_{DD2-100}$ | | $IN+ = \text{High}, IN- = \text{Low}, \text{no load}$ | - | - | 2 | mA |
| I_{EE2-0} | Output Negative Supply Quiescent Current (NCx5708zB) | $IN+ = \text{Low}, IN- = \text{Low}, \text{no load}, V_{EE2} = -8\text{ V}$ | - | - | 2 | mA |
| $I_{EE2-100}$ | | $IN+ = \text{High}, IN- = \text{Low}, \text{no load}, V_{EE2} = -8\text{ V}$ | - | - | 2 | mA |

LOGIC INPUT AND OUTPUT

| | | | | | | |
|----------------|--|---|----------------------|-----------------------|----------------------|---------------|
| V_{IL} | $IN+, IN-, \text{Low Input Voltage}$ | Level scale for $V_{DD1} = 3.3\text{ to }5\text{ V}$ for $V_{DD1} > 5\text{ V}$ is the same as for $V_{DD1} = 5\text{ V}$ | - | - | $0.3 \times V_{DD1}$ | V |
| V_{IH} | $IN+, IN-, \text{High Input Voltage}$ | Level scale for $V_{DD1} = 3.3\text{ to }5\text{ V}$ for $V_{DD1} > 5\text{ V}$ is the same as for $V_{DD1} = 5\text{ V}$ | $0.7 \times V_{DD1}$ | - | - | V |
| $V_{IN-HYST}$ | Input Hysteresis Voltage | Level scale for $V_{DD1} = 3.3\text{ to }5\text{ V}$ for $V_{DD1} > 5\text{ V}$ is the same as for $V_{DD1} = 5\text{ V}$ | - | $0.15 \times V_{DD1}$ | - | V |
| $I_{IN-L-3.3}$ | $IN- \text{ Input Current}$ | $V_{IN-} = 0\text{ V}, V_{DD1} = 3.3\text{ V}$ | - | - | 100 | μA |
| I_{IN-L-5} | | $V_{IN-} = 0\text{ V}$ | - | - | 100 | μA |
| $I_{IN-L-15}$ | | $V_{IN-} = 0\text{ V}, V_{DD1} = 15\text{ V}$ | - | - | 100 | μA |
| $I_{IN-L-20}$ | | $V_{IN-} = 0\text{ V}, V_{DD1} = 20\text{ V}$ | - | - | 100 | μA |
| $I_{IN+H-3.3}$ | $IN+ \text{ Input Current}$ | $V_{IN+} = V_{DD1} = 3.3\text{ V}$ | - | - | 100 | μA |
| I_{IN+H-5} | | $V_{IN+} = V_{DD1} = 5\text{ V}$ | - | - | 100 | μA |
| $I_{IN+H-15}$ | | $V_{IN+} = V_{DD1} = 15\text{ V}$ | - | - | 100 | μA |
| $I_{IN+H-20}$ | | $V_{IN+} = V_{DD1} = 20\text{ V}$ | - | - | 100 | μA |
| $t_{ON-MIN1}$ | Input Pulse Width of $IN+, IN-$ for Guaranteed No Response at Output | | - | - | 10 | ns |
| $t_{ON-MIN2}$ | Input Pulse Width of $IN+, IN-$ for Guaranteed Response at Output | | 40 | - | - | ns |

NCx57080y, NCx57081y

ELECTRICAL CHARACTERISTICS $V_{DD1} = 5\text{ V}$, $V_{DD2} = 15\text{ V}$, ($V_{EE2} = 0\text{ V}$ for NCx5708zB).

For typical values $T_A = 25^\circ\text{C}$, for min/max values, T_A is the operating ambient temperature range that applies, unless otherwise noted.

| Symbol | Parameter | Test Conditions | Min | Typ | Max | Unit |
|----------------------|--|--|-----|------|------|------|
| DRIVER OUTPUT | | | | | | |
| V_{OUTL1} | Output Low State ($V_{OUT} - GND2$ for NCx5708zA) ($V_{OUT} - V_{EE2}$ for NCx5708zB) ($V_{OUTL} - GND2$ for NCx5708zC) | $I_{SINK} = 200\text{ mA}$ | - | 0.15 | 0.3 | V |
| V_{OUTL2} | | $I_{SINK} = 1.0\text{ A}$, $T_A = 25^\circ\text{C}$ (Note 12) | - | - | 0.8 | |
| V_{OUTH1} | Output High State ($V_{DD2} - V_{OUT}$ for NCx5708zA/B) ($V_{DD2} - V_{OUT}$ for NCx5708zB) ($V_{DD2} - V_{OUTL}$ for NCx5708zC) | $I_{SRC} = 200\text{ mA}$ | - | 0.2 | 0.35 | V |
| V_{OUTH2} | | $I_{SRC} = 1.0\text{ A}$, $T_A = 25^\circ\text{C}$ (Note 12) | - | - | 1.0 | |
| $I_{PK-SNK1}$ | Peak Driver Current, Sink (Note 12) | | - | 6.5 | - | A |
| $I_{PK-SRC1}$ | Peak Driver Current, Source (Note 12) | | - | 6.5 | - | A |

MILLER CLAMP (NCx5708zA)

| | | | | | | |
|-----------------|----------------------------|--|-----|---|-----|---|
| V_{CLAMP} | Clamp Voltage | $I_{CLAMP} = 2.5\text{ A}$, $T_A = 25^\circ\text{C}$ | - | 2 | - | V |
| | | $I_{CLAMP} = 2.5\text{ A}$, $T_A = -40^\circ\text{C}$ to 125°C | - | - | 3.5 | |
| $V_{CLAMP-THR}$ | Clamp Activation Threshold | | 1.5 | 2 | 2.5 | V |

IGBT SHORT CIRCUIT CLAMPING

| | | | | | | |
|-------------------|---|---|---|-----|-----|---|
| $V_{CLAMP-OUTH}$ | Clamping Voltage, Sourcing ($V_{OUT} / V_{OUTH} - V_{DD2}$) | $I_{IN+} = \text{Low}$, $I_{IN-} = \text{High}$, $I_{CLAMP-OUT/OUTH} = 500\text{ mA}$, (pulse test, $t_{CLPmax} = 10\text{ }\mu\text{s}$) | - | 0.7 | 1.3 | V |
| $V_{CLAMP-OUTL}$ | Clamping Voltage, Sinking ($V_{OUTL} - V_{DD2}$) | $I_{IN+} = \text{High}$, $I_{IN-} = \text{Low}$, $I_{CLAMP-OUTL} = 500\text{ mA}$, (pulse test, $t_{CLPmax} = 10\text{ }\mu\text{s}$) | - | 0.8 | 1.5 | V |
| $V_{CLAMP-CLAMP}$ | Clamping Voltage, Clamp ($V_{CLAMP} - V_{DD2}$) (NCx5708zA) | $I_{IN+} = \text{High}$, $I_{IN-} = \text{Low}$, $I_{CLAMP-CLAMP} = 500\text{ mA}$ (pulse test, $t_{CLPmax} = 10\text{ }\mu\text{s}$) | - | 1.1 | 1.7 | V |

DYNAMIC CHARACTERISTIC

| | | | | | | |
|--------------------|---|--|-----|----|----|----|
| | IN+, IN- to Output High Propagation Delay | $C_{LOAD} = 10\text{ nF}$ V_{IH} to 10% of output change Pulse Width > 150 ns. | - | - | - | - |
| $t_{PD-ON-3.3}$ | | $V_{DD1} = V_{IN+} = 3.3\text{ V}$, $V_{IN-} = 0\text{ V}$ | 40 | 60 | 90 | ns |
| $t_{PD-ON-5}$ | | $V_{DD1} = V_{IN+} = 5\text{ V}$, $V_{IN-} = 0\text{ V}$ | 40 | 60 | 90 | ns |
| $t_{PD-ON-15}$ | | $V_{DD1} = V_{IN+} = 15\text{ V}$, $V_{IN-} = 0\text{ V}$ | 40 | 60 | 90 | ns |
| $t_{PD-ON-20}$ | | $V_{DD1} = V_{IN+} = 20\text{ V}$, $V_{IN-} = 0\text{ V}$ | 40 | 60 | 90 | ns |
| | IN+, IN- to Output Low Propagation Delay | $C_{LOAD} = 10\text{ nF}$ V_{IH} to 10% of output change Pulse Width > 150 ns. | - | - | - | - |
| $t_{PD-OFF-3.3}$ | | $V_{DD1} = V_{IN+} = 3.3\text{ V}$, $V_{IN-} = 0\text{ V}$ | 40 | 60 | 90 | ns |
| $t_{PD-OFF-5}$ | | $V_{DD1} = V_{IN+} = 5\text{ V}$, $V_{IN-} = 0\text{ V}$ | 40 | 60 | 90 | ns |
| $t_{PD-OFF-15}$ | | $V_{DD1} = V_{IN+} = 15\text{ V}$, $V_{IN-} = 0\text{ V}$ | 40 | 60 | 90 | ns |
| $t_{PD-OFF-20}$ | | $V_{DD1} = V_{IN+} = 20\text{ V}$, $V_{IN-} = 0\text{ V}$ | 40 | 60 | 90 | ns |
| $t_{DISTORT}$ | Propagation Delay Distortion (= $t_{PD-ON} - t_{PD-OFF}$) | $T_A = 25^\circ\text{C}$, $PW > 150\text{ ns}$ | - | 0 | - | ns |
| | | $T_A = -40^\circ\text{C}$ to 125°C , $PW > 150\text{ ns}$ | -25 | - | 25 | ns |
| $t_{DISTORT_TOT}$ | Prop Delay Distortion between Parts | $PW > 150\text{ ns}$ | -30 | 0 | 30 | ns |
| t_{RISE} | Rise Time (see Figure 8) | $C_{LOAD} = 1\text{ nF}$, 10% to 90% of Output Change | - | 13 | - | ns |
| t_{FALL} | Fall Time (see Figure 8) | $C_{LOAD} = 1\text{ nF}$, 90% to 10% of Output Change | - | 13 | - | ns |

NCx57080y, NCx57081y

ELECTRICAL CHARACTERISTICS $V_{DD1} = 5\text{ V}$, $V_{DD2} = 15\text{ V}$, ($V_{EE2} = 0\text{ V}$ for NCx5708zB).

For typical values $T_A = 25^\circ\text{C}$, for min/max values, T_A is the operating ambient temperature range that applies, unless otherwise noted.

| Symbol | Parameter | Test Conditions | Min | Typ | Max | Unit |
|-------------------------------|----------------------------|-----------------|-----|------|-----|------|
| DYNAMIC CHARACTERISTIC | | | | | | |
| t_{UVF1} | UVLO1 Fall Delay (Note 12) | | – | 1500 | – | ns |
| t_{UVR1} | UVLO1 Rise Delay (Note 12) | | – | 770 | – | ns |
| t_{UVF2} | UVLO2 Fall Delay (Note 12) | | – | 1000 | – | ns |
| t_{UVR2} | UVLO2 Rise Delay (Note 12) | | – | 1000 | – | ns |

Product parametric performance is indicated in the Electrical Characteristics for the listed test conditions, unless otherwise noted. Product performance may not be indicated by the Electrical Characteristics if operated under different conditions.

12. Values based on design and/or characterization.

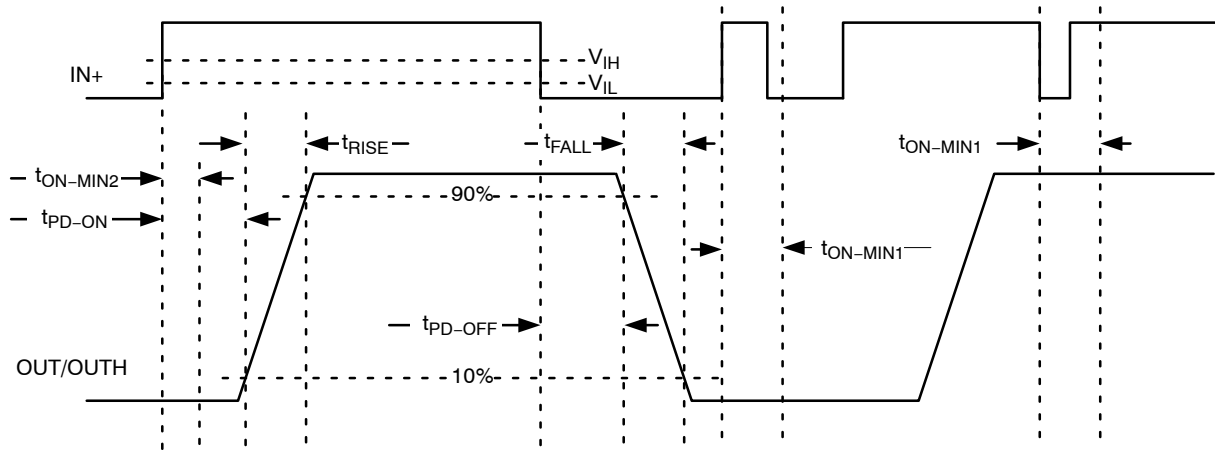
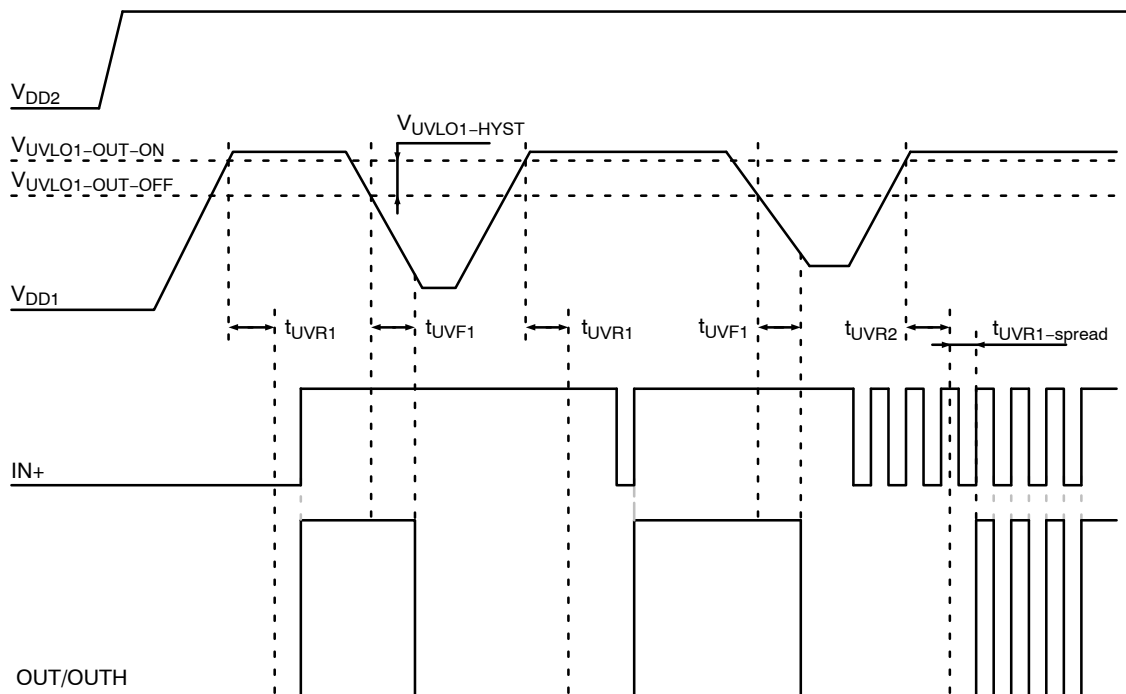

Figure 8. Propagation Delay, Rise and Fall time



Output Ramp-up and Ramp-down Times during UVLO1

Figure 9A. UVLO1 and Associated Timing Waveforms

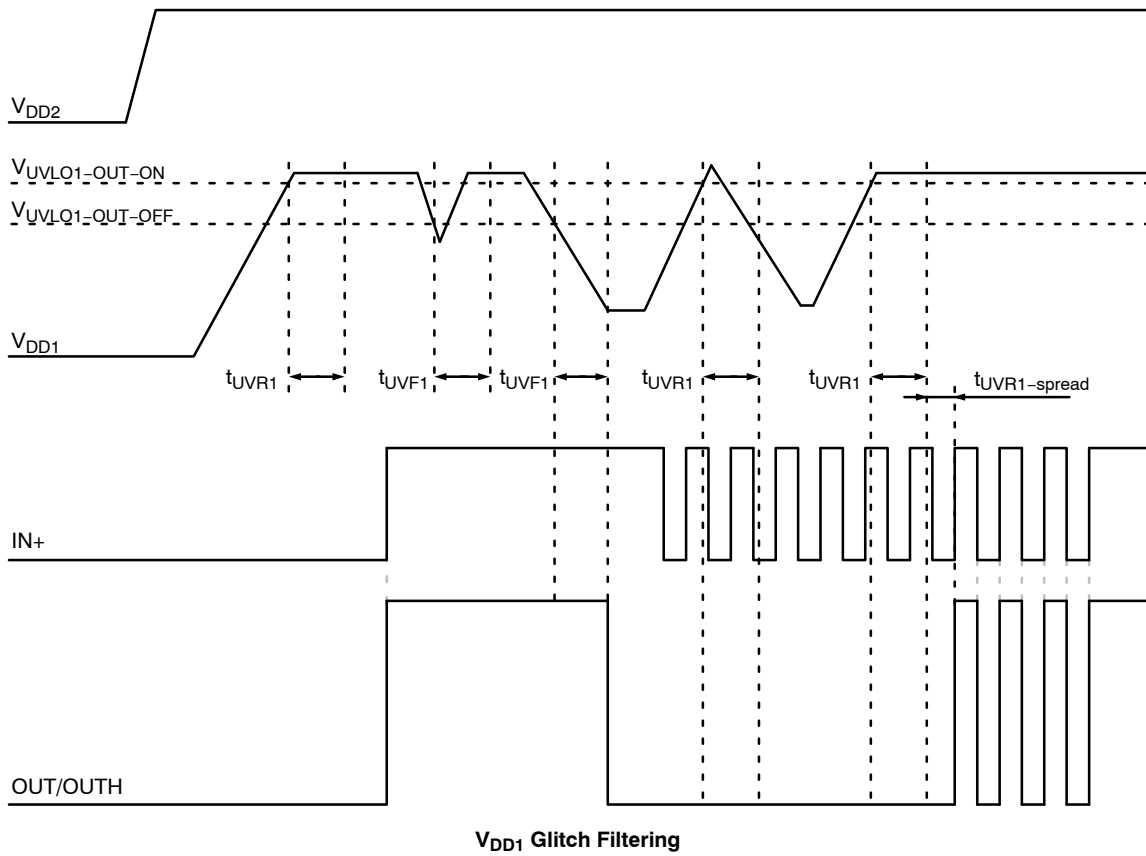

Figure 9B. UVLO1 Waveforms Depicting V_{DD1} Glitch Filtering

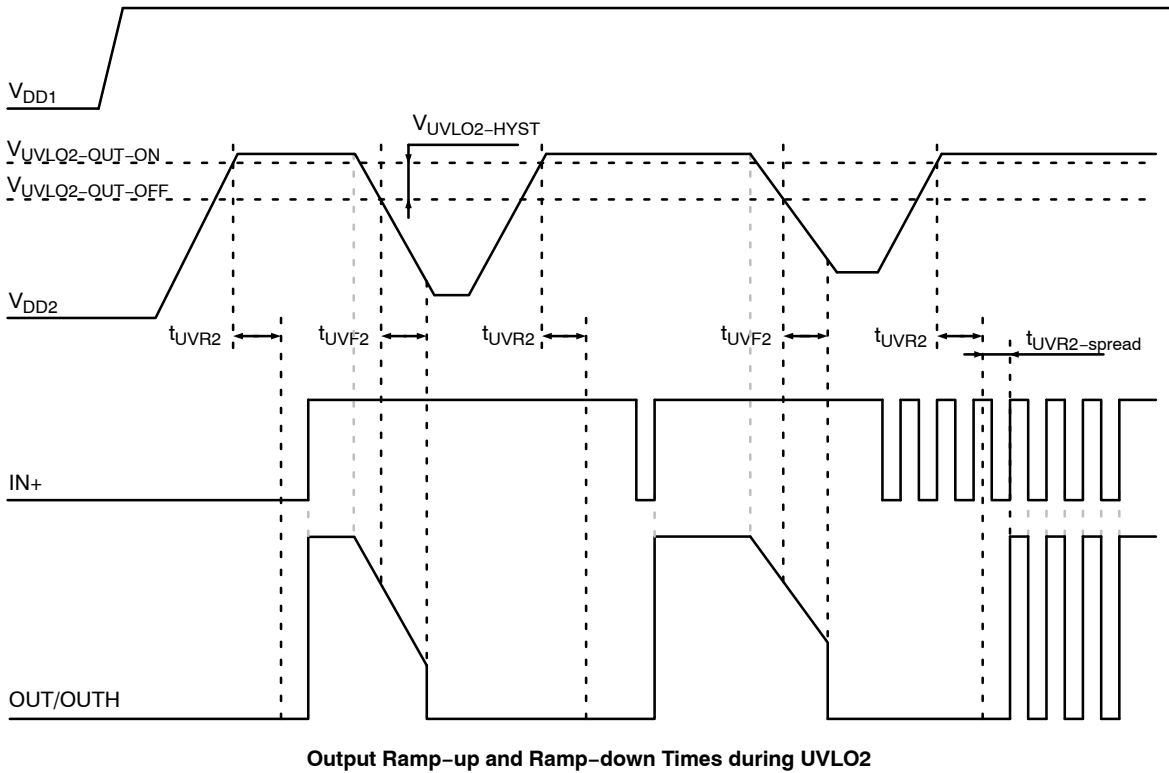
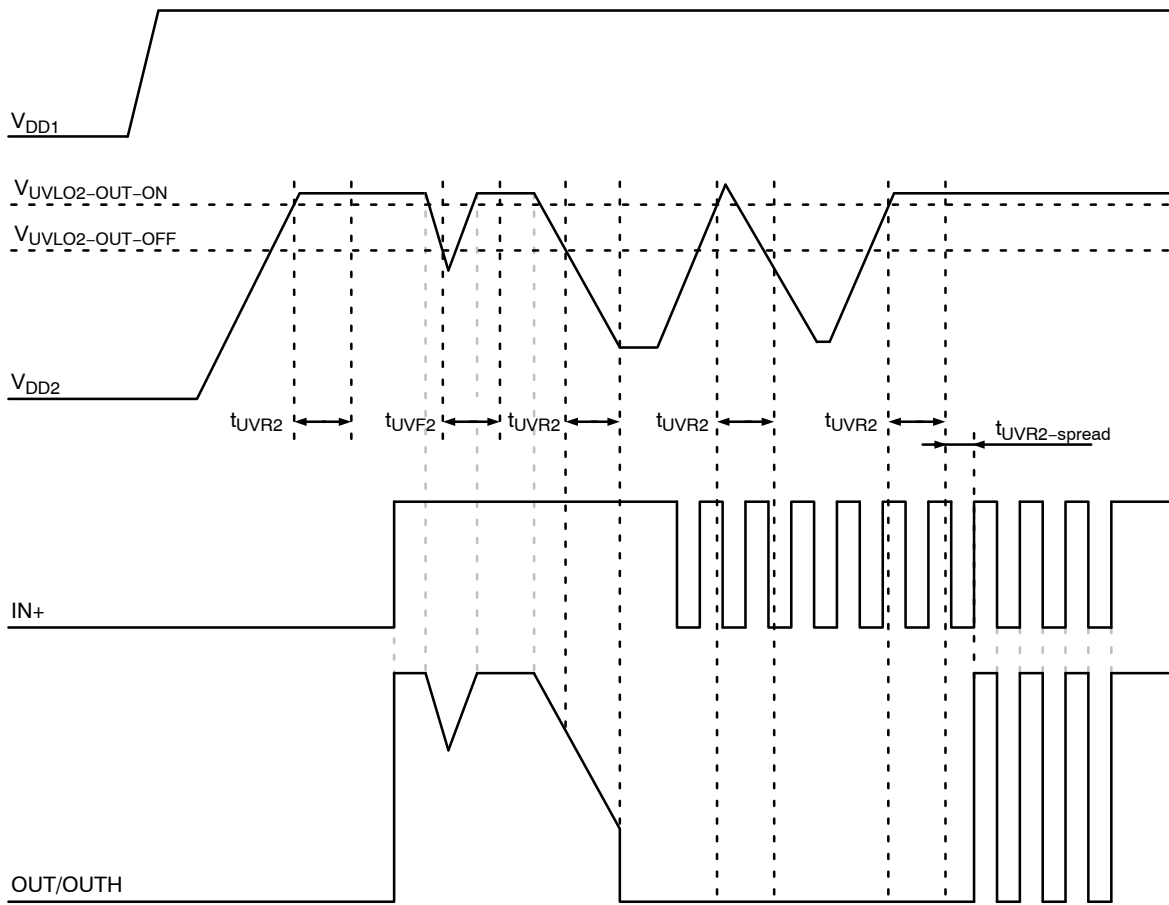

Figure 9C. UVLO2 and Associated Timing Waveforms

NCx57080y, NCx57081y



V_{DD2} Glitch Filtering

Figure 9D. UVLO2 Waveforms Depicting V_{DD2} Glitch Filtering

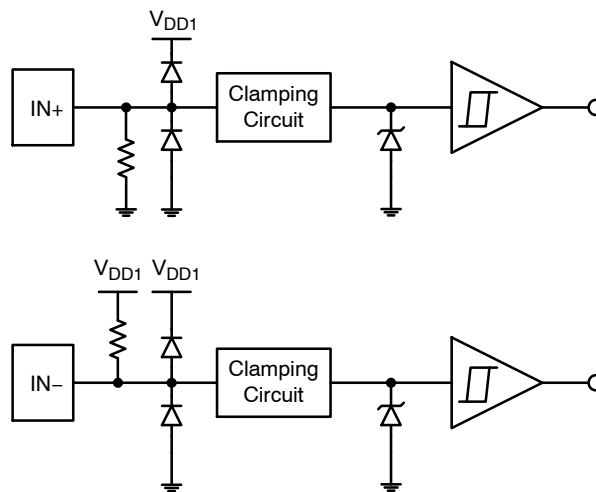

Figure 10. Input Pin Structure

NCx57080y, NCx57081y

TYPICAL CHARACTERISTICS

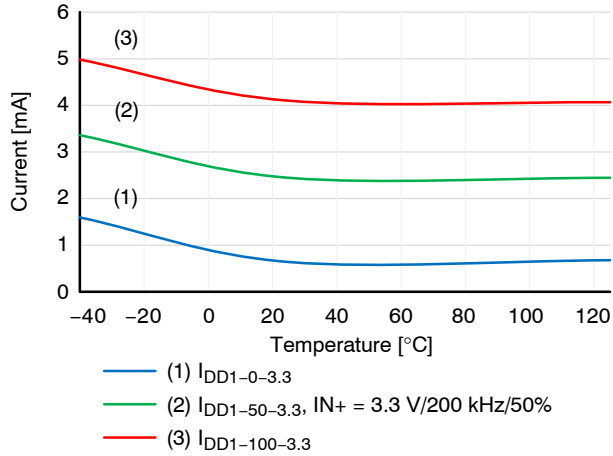

Figure 11. I_{DD1} Supply Current $V_{DD1} = 3.3$ V

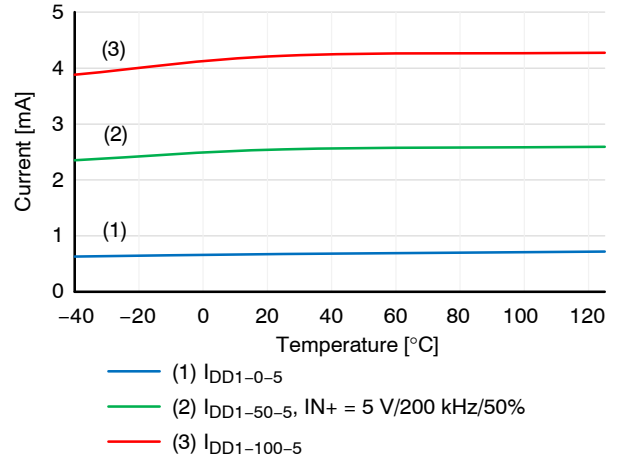

Figure 12. I_{DD1} Supply Current $V_{DD1} = 5$ V

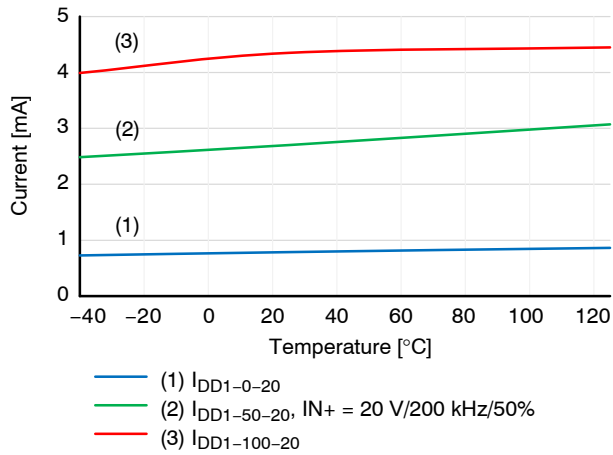

Figure 13. I_{DD1} Supply Current $V_{DD1} = 20$ V

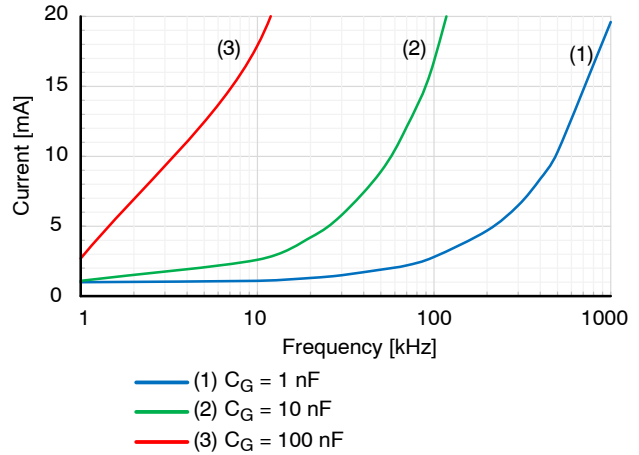

Figure 14. I_{DD2} vs. Switching Frequency

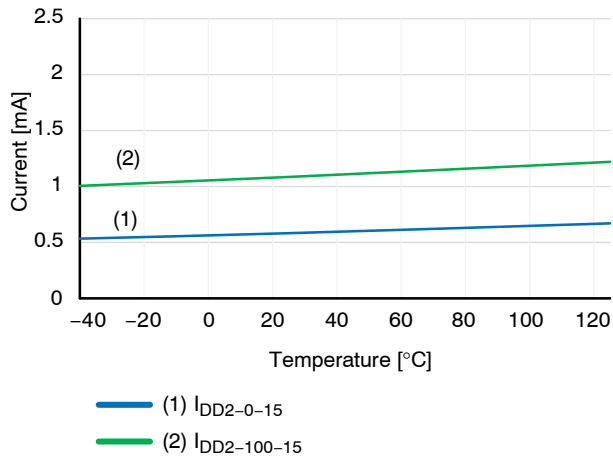

Figure 15. I_{DD2} Supply Current $V_{DD2} = 15$ V

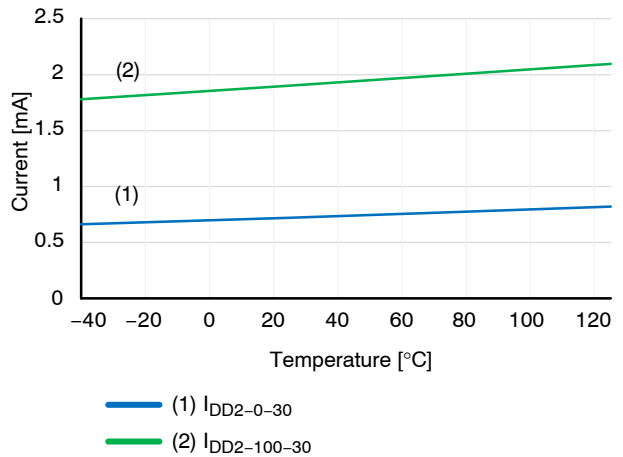

Figure 16. I_{DD2} Supply Current $V_{DD2} = 30$ V

NCx57080y, NCx57081y

TYPICAL CHARACTERISTICS (continued)

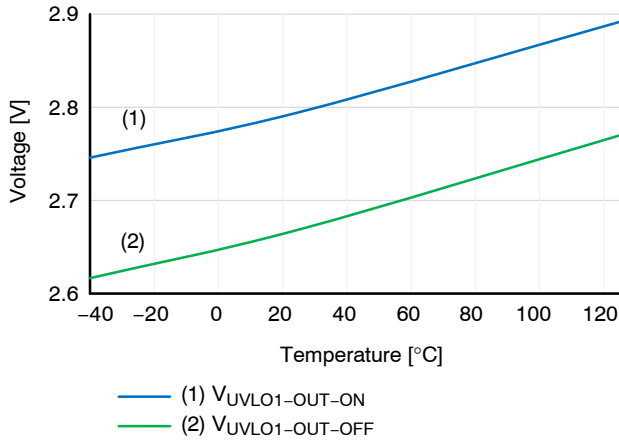

Figure 17. UVLO1 Threshold Voltage

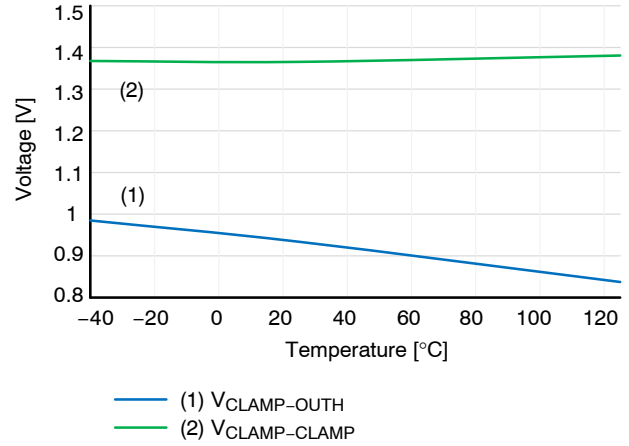

Figure 18. IGBT Short Circuit CLAMP Voltage Drop

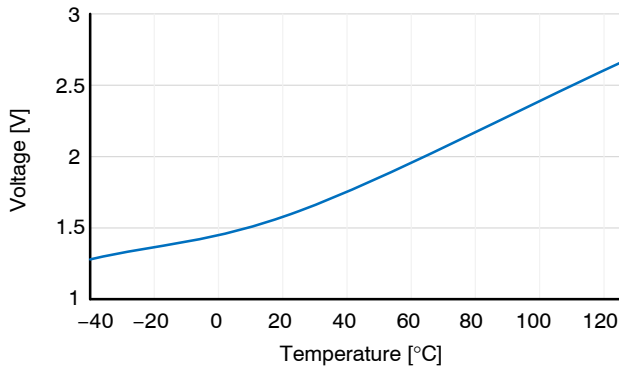

Figure 19a. Miller Clamp Voltage (2.5 A)

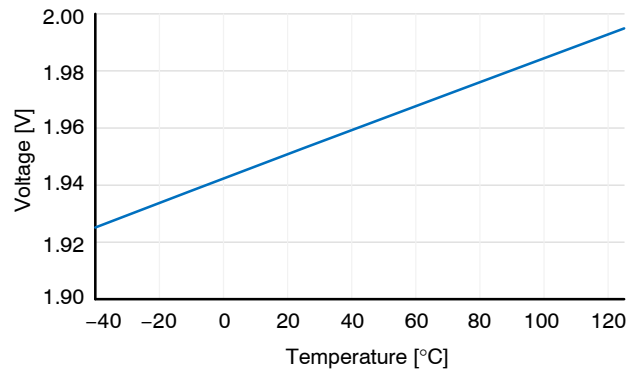

Figure 19b. Miller Clamp Activation Voltage Threshold

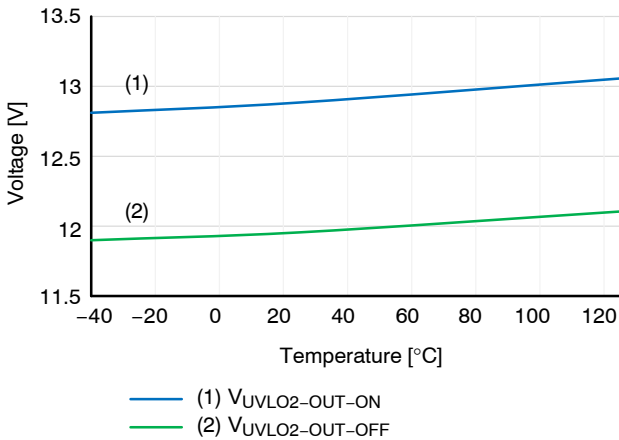

Figure 20. NCx57080 UVLO2 Threshold Voltage

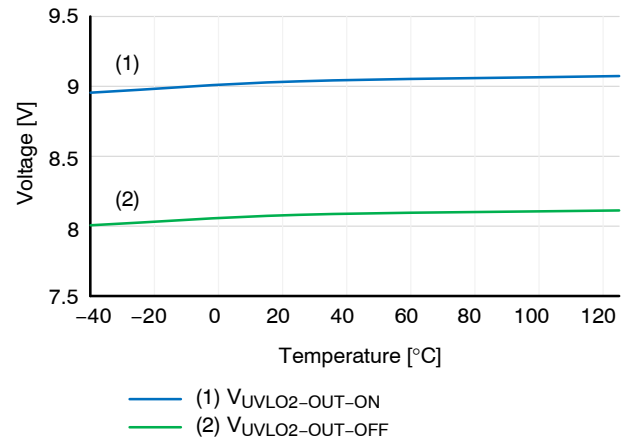

Figure 21. NCx57081 UVLO2 Threshold Voltage

NCx57080y, NCx57081y

TYPICAL CHARACTERISTICS (continued)

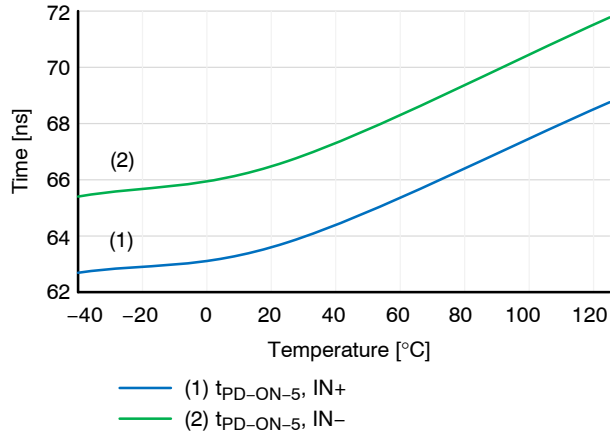

Figure 22. Propagation Delay Turn-on

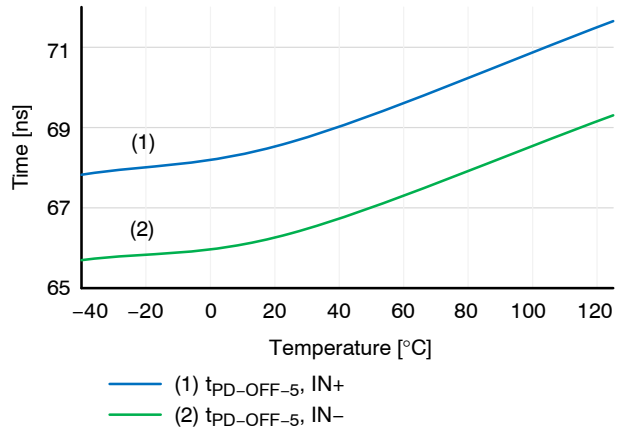

Figure 23. Propagation Delay Turn-off

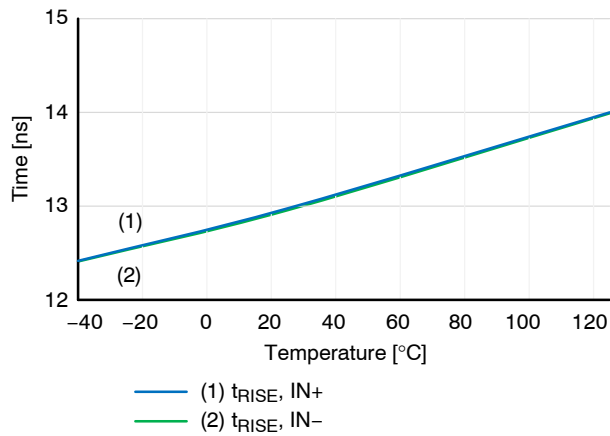

Figure 24. Rise Time, $V_{DD1} = 5\text{ V}$

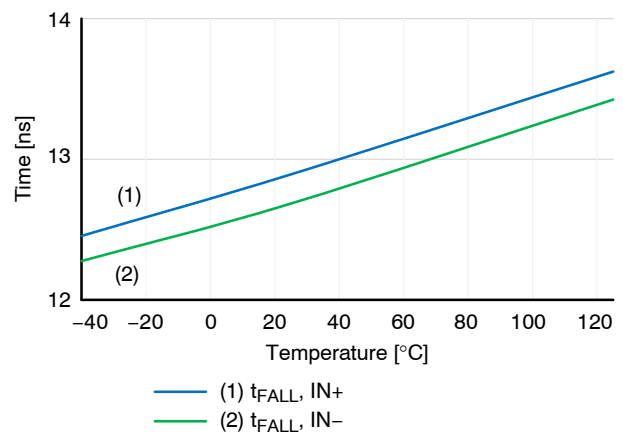

Figure 25. Fall Time, $V_{DD1} = 5\text{ V}$

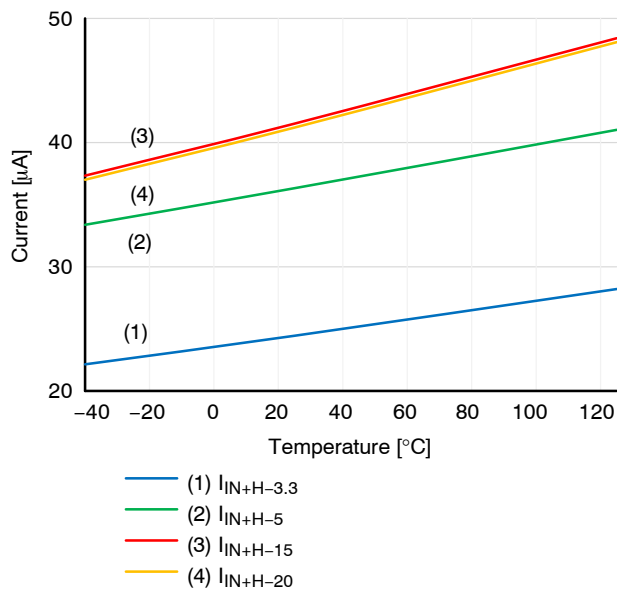

Figure 26. Input Current - Positive Input

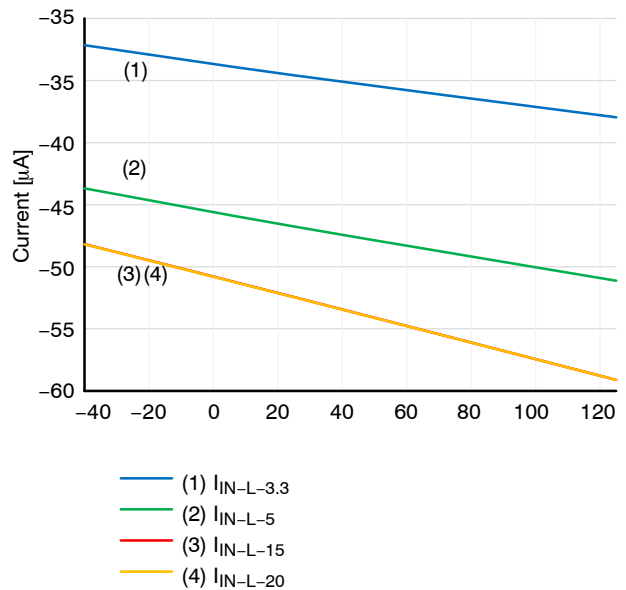

Figure 27. Input Current - Negative Input

Under Voltage Lockout (Refer to Figure 9x)

UVLO ensures correct switching of IGBT/MOSFET connected to the driver output.

- The IGBT/MOSFET is turned-off and the output is disabled if the supply V_{DD1} drops below $V_{UVLO1-OUT-OFF}$ or V_{DD2} drops below $V_{UVLO2-OUT-OFF}$.
- The driver output does not follow the input signal on $IN+$ or $IN-$ until the V_{DDX} rises above the $V_{UVLOX-OUT-ON}$ and the input signal rising edge is applied to the $IN+$ or $IN-$.
- V_{EE2} is not monitored (NCx5708zB)

With high loading gate capacitances over 10 nF it is important to follow the decoupling capacitor routing guidelines as shown on Figure 35. The decoupling capacitor value should be at least 10 μ F. Also gate resistor of minimal

value of 2 Ω has to be used in order to avoid interference of the high di/dt with internal circuitry (e.g. UVLO2).

After the power-on of the driver there has to be a rising edge applied to the $IN+$ or falling edge to the $IN-$ in order for the output to start following the inputs. This serves as a protection against producing partial pulses at the output if the V_{DD1} or V_{DD2} is applied in the middle of the input PWM pulse.

If the V_{DD2} rises over $V_{UVLO2-OUT-ON}$ level the PWM will appear on the output after $t_{UVR2} + t_{UVR2-spread}$. The $t_{UVR2-spread}$ time is variable and is defined as a time from end of t_{UVR2} to first rising edge on $IN+$ input. If the V_{DD2} is starting from 0 V the time until PWM is at the output of the driver is longer than $t_{UVR2} + t_{UVR2-spread}$. This is caused by start up time of internal circuits of the driver.

ACTIVE MILLER CLAMP PROTECTION (CLAMP)

NCx5708yB supports bipolar power supply to prevent unintentional turning on.

For operation with bipolar supplies, the IGBT/MOSFET is turned off with a negative voltage through OUT with respect to its emitter. This prevents the IGBT/MOSFET from unintentionally turning on because of current induced from its collector to its gate due to Miller effect. Typical values for bipolar operation are $V_{DD2} = 15\text{ V}$ and $V_{EE2} = -5\text{ V}$ with respect to GND2.

Driver version A supports unipolar power supply with active Miller clamp.

For operation with unipolar supply, typically, $V_{DD2} = 15\text{ V}$ with respect to GND2, and $V_{EE2} = \text{GND2}$. In this case, the IGBT/MOSFET can turn on due to additional charge from IGBT/MOSFET Miller capacitance caused by a high voltage slew rate transition on the IGBT collector/MOSFET drain. To prevent IGBT/MOSFET to turn on, the CLAMP pin is connected directly to IGBT/MOSFET gate and Miller current is sunk through a low impedance CLAMP transistor. When the IGBT/MOSFET is turned-off and the gate voltage transitions below V_{CLAMP} the CLAMP output is activated.

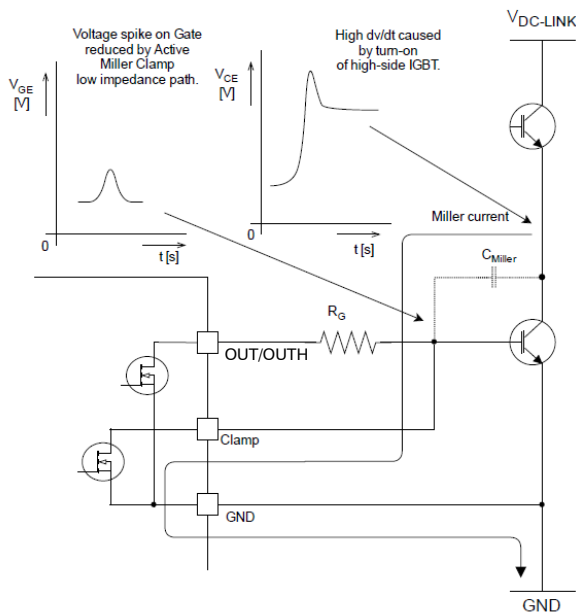

Figure 28. Current Path with Miller Clamp Protection

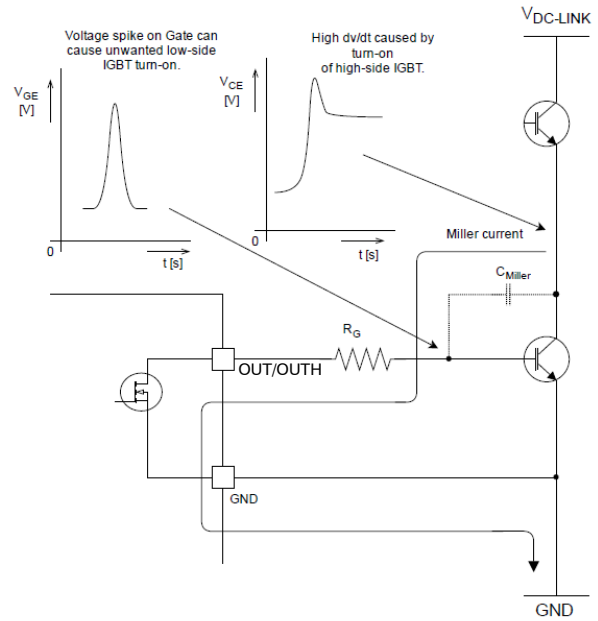

Figure 29. Current Path without Miller Clamp Protection

Non-inverting and Inverting Input Pin (IN+, IN-)

The driver has two possible input modes to control IGBT/MOSFET. Both inputs have defined minimum input pulse width to filter occasional glitches.

- Non-inverting input IN+ controls the driver output while inverting input IN- is set to LOW
- Inverting input IN- controls the driver output while non-inverting input IN+ is set to HIGH

WARNING: When the application uses an independent or separate power supply for the control unit and the input side of the driver, all inputs should be protected by a serial resistor (In case of a power failure of the driver, the driver may be damaged due to overloading of the input protection circuits)

NCx57080y, NCx57081y

Power Supply (V_{DD1} , V_{DD2} , V_{EE2})

The driver variant A and C are designed to support unipolar power supply.

The driver variant B is designed to support bipolar power supply.

Suitable external power capacitors are required for reliable driving of IGBT/MOSFET gate with high current. Parallel combination of 100 nF + 4.7 μ F low ESR ceramic capacitors is optimal for a wide range of applications using IGBT/MOSFET. For reliable driving of IGBT modules (containing several parallel IGBT's) with a gate capacitance over 10 nF a higher decoupling capacity is required (typically 100 nF + 10 μ F). Capacitors should be as close as possible to the driver's power pins. The recommended layout is provided in the Figure 35.

- In bipolar power supply the driver is typically supplied with a positive voltage of 15 V at V_{DD2} and negative voltage -5 V at V_{EE2} (Figure 30). Negative power supply prevents a dynamic turn on through the internal IGBT/MOSFET input capacitance
- In Unipolar power supply the driver is typically supplied with a positive voltage of 15 V at V_{DD2} . Unwanted turn-on caused by the internal IGBT/MOSFET Miller capacitance could be prevented by Active Miller Clamp function (variant A). CLAMP output should be directly connected to IGBT/MOSFET gate (Figure 28)

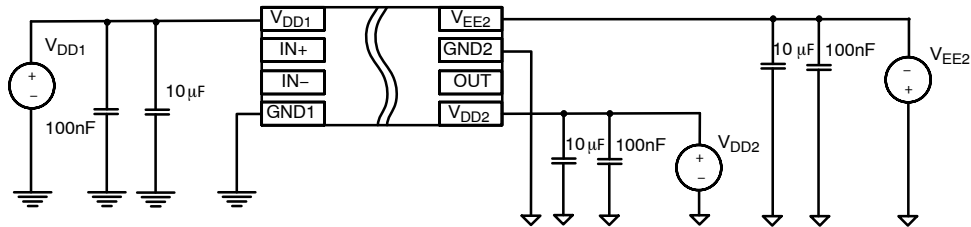

Figure 30. Bipolar Power Supply (NCx5708zB)

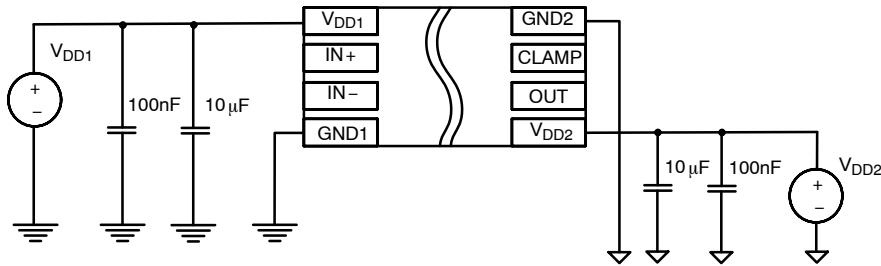

Figure 31. Unipolar Power Supply (NCx5708zA)

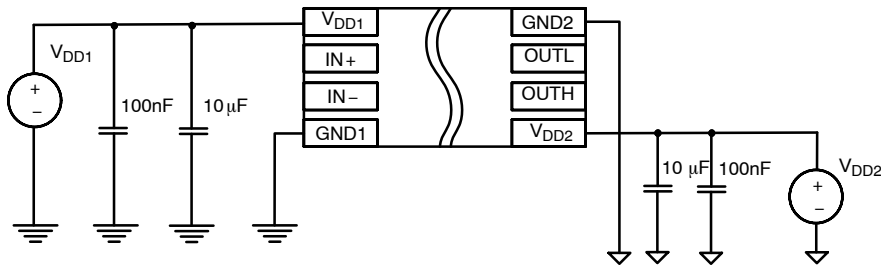

Figure 32. Unipolar Power Supply (NCx5708zC)

NCx57080y, NCx57081y

Common Mode Transient Immunity (CMTI)

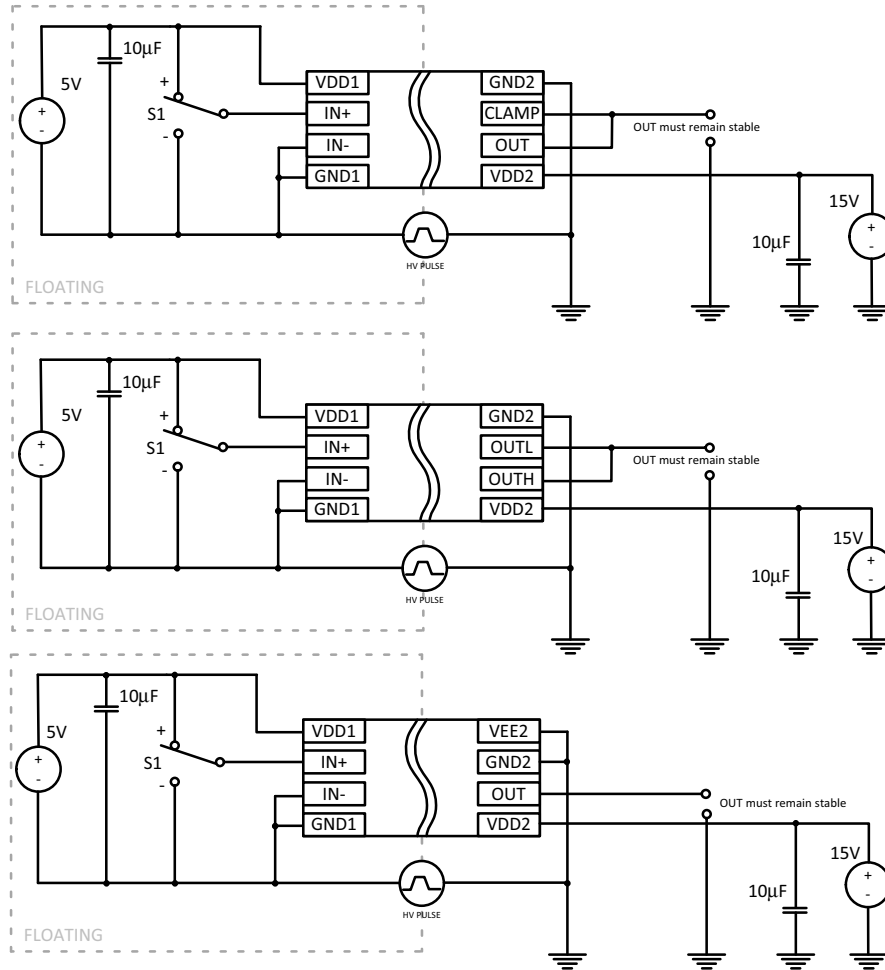

Figure 33. Common-Mode Transient Immunity Test Circuit

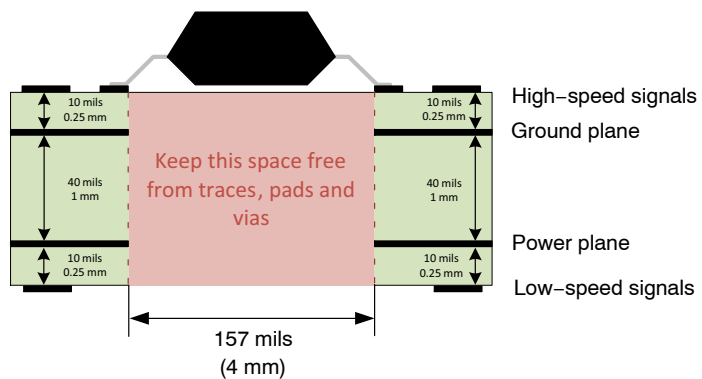

Figure 34. Recommended Layer Stack

NCx57080y, NCx57081y

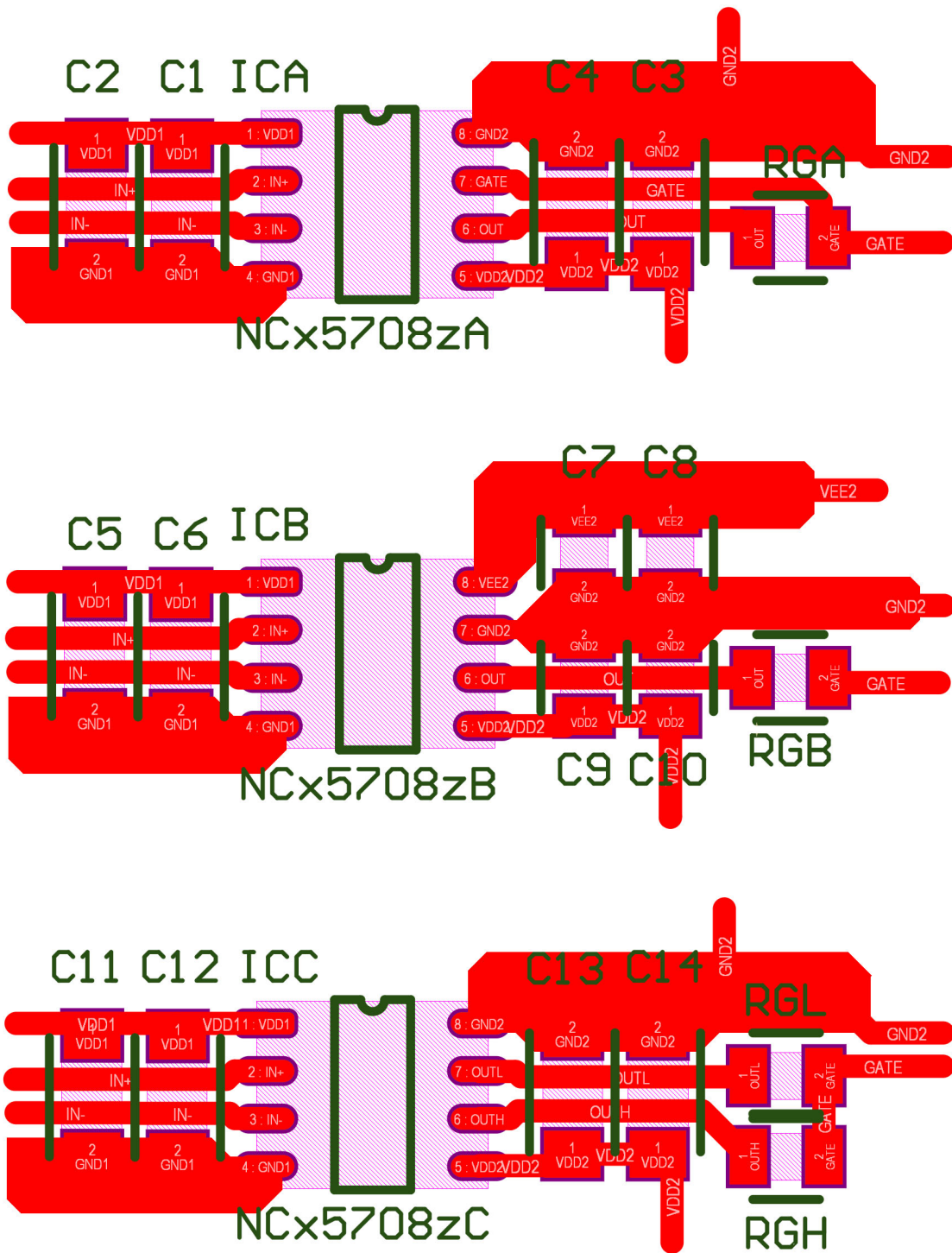

Figure 35. Recommended Layout for Version A/B/C

NCx57080y, NCx57081y

ORDERING INFORMATION

| Device | Qualification | Package | Shipping [†] |
|----------------|--|---------------------------------|-----------------------|
| NCD57080ADR2G | Industrial | SOIC-8 Narrow Body (Pb-Free) | 2500 / Tape & Reel |
| NCD57080BDR2G | | | |
| NCD57080CDR2G | | | |
| NCV57080ADR2G* | Automotive (AEC-Q100 Qualified and PPAP Capable) | SOIC-8 Narrow Body (Pb-Free) | 2500 / Tape & Reel |
| NCV57080BDR2G* | | | |
| NCV57080CDR2G* | | | |
| NCD57081ADR2G | Industrial | SOIC-8 Narrow Body (Pb-Free) | 2500 / Tape & Reel |
| NCD57081BDR2G | | | |
| NCD57081CDR2G | | | |
| NCV57081ADR2G* | Automotive (AEC-Q100 Qualified and PPAP Capable) | SOIC-8 Narrow Body (Pb-Free) | 2500 / Tape & Reel |
| NCV57081BDR2G* | | | |
| NCV57081CDR2G* | | | |

[†]For information on tape and reel specifications, including part orientation and tape sizes, please refer to our Tape and Reel Packaging Specifications Brochure, BRD8011/D.

*NCV Prefix for Automotive and Other Applications Requiring Unique Site and Control Change Requirements; AEC-Q100 Qualified and PPAP Capable.

MECHANICAL CASE OUTLINE PACKAGE DIMENSIONS

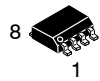

SCALE 1:1

SOIC-8 NB
CASE 751-07
ISSUE AK

DATE 16 FEB 2011

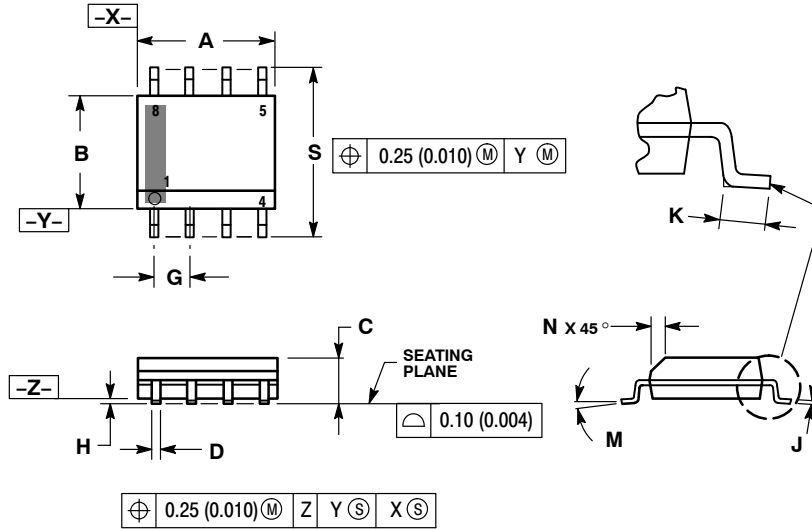

- NOTES:
1. DIMENSIONING AND TOLERANCING PER ANSI Y14.5M, 1982.
 2. CONTROLLING DIMENSION: MILLIMETER.
 3. DIMENSION A AND B DO NOT INCLUDE MOLD PROTRUSION.
 4. MAXIMUM MOLD PROTRUSION 0.15 (0.006) PER SIDE.
 5. DIMENSION D DOES NOT INCLUDE DAMBAR PROTRUSION. ALLOWABLE DAMBAR PROTRUSION SHALL BE 0.127 (0.005) TOTAL IN EXCESS OF THE D DIMENSION AT MAXIMUM MATERIAL CONDITION.
 6. 751-01 THRU 751-06 ARE OBSOLETE. NEW STANDARD IS 751-07.

| DIM | MILLIMETERS | | INCHES | |
|-----|-------------|------|-----------|-------|
| | MIN | MAX | MIN | MAX |
| A | 4.80 | 5.00 | 0.189 | 0.197 |
| B | 3.80 | 4.00 | 0.150 | 0.157 |
| C | 1.35 | 1.75 | 0.053 | 0.069 |
| D | 0.33 | 0.51 | 0.013 | 0.020 |
| G | 1.27 BSC | | 0.050 BSC | |
| H | 0.10 | 0.25 | 0.004 | 0.010 |
| J | 0.19 | 0.25 | 0.007 | 0.010 |
| K | 0.40 | 1.27 | 0.016 | 0.050 |
| M | 0° | 8° | 0° | 8° |
| N | 0.25 | 0.50 | 0.010 | 0.020 |
| S | 5.80 | 6.20 | 0.228 | 0.244 |

SOLDERING FOOTPRINT*

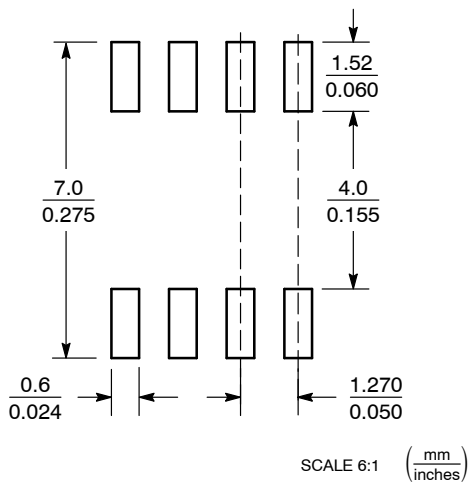

*For additional information on our Pb-Free strategy and soldering details, please download the ON Semiconductor Soldering and Mounting Techniques Reference Manual, SOLDERRM/D.

GENERIC MARKING DIAGRAM*

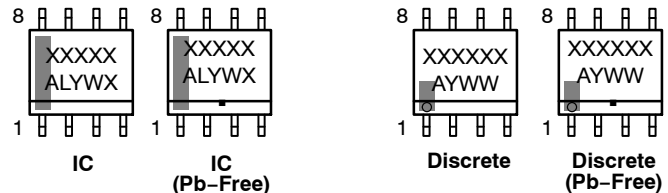

XXXXXX = Specific Device Code
A = Assembly Location
L = Wafer Lot
Y = Year
W = Work Week
▪ = Pb-Free Package

XXXXXX = Specific Device Code
A = Assembly Location
Y = Year
WW = Work Week
▪ = Pb-Free Package

*This information is generic. Please refer to device data sheet for actual part marking. Pb-Free indicator, "G" or microdot "▪", may or may not be present. Some products may not follow the Generic Marking.

STYLES ON PAGE 2

| | | |
|------------------|-------------|--|
| DOCUMENT NUMBER: | 98ASB42564B | Electronic versions are uncontrolled except when accessed directly from the Document Repository. Printed versions are uncontrolled except when stamped "CONTROLLED COPY" in red. |
| DESCRIPTION: | SOIC-8 NB | PAGE 1 OF 2 |

onsemi and ONsemi are trademarks of Semiconductor Components Industries, LLC dba onsemi or its subsidiaries in the United States and/or other countries. onsemi reserves the right to make changes without further notice to any products herein. onsemi makes no warranty, representation or guarantee regarding the suitability of its products for any particular purpose, nor does onsemi assume any liability arising out of the application or use of any product or circuit, and specifically disclaims any and all liability, including without limitation special, consequential or incidental damages. onsemi does not convey any license under its patent rights nor the rights of others.

SOIC-8 NB
CASE 751-07
ISSUE AK

DATE 16 FEB 2011

- | | | | |
|---|--|--|--|
| <p>STYLE 1: PIN 1. EMITTER 2. COLLECTOR 3. COLLECTOR 4. EMITTER 5. EMITTER 6. BASE 7. BASE 8. EMITTER</p> | <p>STYLE 2: PIN 1. COLLECTOR, DIE, #1 2. COLLECTOR, #1 3. COLLECTOR, #2 4. COLLECTOR, #2 5. BASE, #2 6. EMITTER, #2 7. BASE, #1 8. EMITTER, #1</p> | <p>STYLE 3: PIN 1. DRAIN, DIE #1 2. DRAIN, #1 3. DRAIN, #2 4. DRAIN, #2 5. GATE, #2 6. SOURCE, #2 7. GATE, #1 8. SOURCE, #1</p> | <p>STYLE 4: PIN 1. ANODE 2. ANODE 3. ANODE 4. ANODE 5. ANODE 6. ANODE 7. ANODE 8. COMMON CATHODE</p> |
| <p>STYLE 5: PIN 1. DRAIN 2. DRAIN 3. DRAIN 4. DRAIN 5. GATE 6. GATE 7. SOURCE 8. SOURCE</p> | <p>STYLE 6: PIN 1. SOURCE 2. DRAIN 3. DRAIN 4. SOURCE 5. SOURCE 6. GATE 7. GATE 8. SOURCE</p> | <p>STYLE 7: PIN 1. INPUT 2. EXTERNAL BYPASS 3. THIRD STAGE SOURCE 4. GROUND 5. DRAIN 6. GATE 3 7. SECOND STAGE Vd 8. FIRST STAGE Vd</p> | <p>STYLE 8: PIN 1. COLLECTOR, DIE #1 2. BASE, #1 3. BASE, #2 4. COLLECTOR, #2 5. COLLECTOR, #2 6. EMITTER, #2 7. EMITTER, #1 8. COLLECTOR, #1</p> |
| <p>STYLE 9: PIN 1. EMITTER, COMMON 2. COLLECTOR, DIE #1 3. COLLECTOR, DIE #2 4. EMITTER, COMMON 5. EMITTER, COMMON 6. BASE, DIE #2 7. BASE, DIE #1 8. EMITTER, COMMON</p> | <p>STYLE 10: PIN 1. GROUND 2. BIAS 1 3. OUTPUT 4. GROUND 5. GROUND 6. BIAS 2 7. INPUT 8. GROUND</p> | <p>STYLE 11: PIN 1. SOURCE 1 2. GATE 1 3. SOURCE 2 4. GATE 2 5. DRAIN 2 6. DRAIN 2 7. DRAIN 1 8. DRAIN 1</p> | <p>STYLE 12: PIN 1. SOURCE 2. SOURCE 3. SOURCE 4. GATE 5. DRAIN 6. DRAIN 7. DRAIN 8. DRAIN</p> |
| <p>STYLE 13: PIN 1. N.C. 2. SOURCE 3. SOURCE 4. GATE 5. DRAIN 6. DRAIN 7. DRAIN 8. DRAIN</p> | <p>STYLE 14: PIN 1. N-SOURCE 2. N-GATE 3. P-SOURCE 4. P-GATE 5. P-DRAIN 6. P-DRAIN 7. N-DRAIN 8. N-DRAIN</p> | <p>STYLE 15: PIN 1. ANODE 1 2. ANODE 1 3. ANODE 1 4. ANODE 1 5. CATHODE, COMMON 6. CATHODE, COMMON 7. CATHODE, COMMON 8. CATHODE, COMMON</p> | <p>STYLE 16: PIN 1. EMITTER, DIE #1 2. BASE, DIE #1 3. EMITTER, DIE #2 4. BASE, DIE #2 5. COLLECTOR, DIE #2 6. COLLECTOR, DIE #2 7. COLLECTOR, DIE #1 8. COLLECTOR, DIE #1</p> |
| <p>STYLE 17: PIN 1. VCC 2. V2OUT 3. V1OUT 4. TXE 5. RXE 6. VEE 7. GND 8. ACC</p> | <p>STYLE 18: PIN 1. ANODE 2. ANODE 3. SOURCE 4. GATE 5. DRAIN 6. DRAIN 7. CATHODE 8. CATHODE</p> | <p>STYLE 19: PIN 1. SOURCE 1 2. GATE 1 3. SOURCE 2 4. GATE 2 5. DRAIN 2 6. MIRROR 2 7. DRAIN 1 8. MIRROR 1</p> | <p>STYLE 20: PIN 1. SOURCE (N) 2. GATE (N) 3. SOURCE (P) 4. GATE (P) 5. DRAIN 6. DRAIN 7. DRAIN 8. DRAIN</p> |
| <p>STYLE 21: PIN 1. CATHODE 1 2. CATHODE 2 3. CATHODE 3 4. CATHODE 4 5. CATHODE 5 6. COMMON ANODE 7. COMMON ANODE 8. CATHODE 6</p> | <p>STYLE 22: PIN 1. I/O LINE 1 2. COMMON CATHODE/VCC 3. COMMON CATHODE/VCC 4. I/O LINE 3 5. COMMON ANODE/GND 6. I/O LINE 4 7. I/O LINE 5 8. COMMON ANODE/GND</p> | <p>STYLE 23: PIN 1. LINE 1 IN 2. COMMON ANODE/GND 3. COMMON ANODE/GND 4. LINE 2 IN 5. LINE 2 OUT 6. COMMON ANODE/GND 7. COMMON ANODE/GND 8. LINE 1 OUT</p> | <p>STYLE 24: PIN 1. BASE 2. EMITTER 3. COLLECTOR/ANODE 4. COLLECTOR/ANODE 5. CATHODE 6. CATHODE 7. COLLECTOR/ANODE 8. COLLECTOR/ANODE</p> |
| <p>STYLE 25: PIN 1. VIN 2. N/C 3. REXT 4. GND 5. IOUT 6. IOUT 7. IOUT 8. IOUT</p> | <p>STYLE 26: PIN 1. GND 2. dv/dt 3. ENABLE 4. ILIMIT 5. SOURCE 6. SOURCE 7. SOURCE 8. VCC</p> | <p>STYLE 27: PIN 1. ILIMIT 2. OVLO 3. UVLO 4. INPUT+ 5. SOURCE 6. SOURCE 7. SOURCE 8. DRAIN</p> | <p>STYLE 28: PIN 1. SW_TO_GND 2. DASIC_OFF 3. DASIC_SW_DET 4. GND 5. V_MON 6. VBULK 7. VBULK 8. VIN</p> |
| <p>STYLE 29: PIN 1. BASE, DIE #1 2. EMITTER, #1 3. BASE, #2 4. EMITTER, #2 5. COLLECTOR, #2 6. COLLECTOR, #2 7. COLLECTOR, #1 8. COLLECTOR, #1</p> | <p>STYLE 30: PIN 1. DRAIN 1 2. DRAIN 1 3. GATE 2 4. SOURCE 2 5. SOURCE 1/DRAIN 2 6. SOURCE 1/DRAIN 2 7. SOURCE 1/DRAIN 2 8. GATE 1</p> | | |

| | | |
|-------------------------|--------------------|---|
| DOCUMENT NUMBER: | 98ASB42564B | Electronic versions are uncontrolled except when accessed directly from the Document Repository. Printed versions are uncontrolled except when stamped "CONTROLLED COPY" in red. |
| DESCRIPTION: | SOIC-8 NB | PAGE 2 OF 2 |

onsemi and **ONSEMI** are trademarks of Semiconductor Components Industries, LLC dba **onsemi** or its subsidiaries in the United States and/or other countries. **onsemi** reserves the right to make changes without further notice to any products herein. **onsemi** makes no warranty, representation or guarantee regarding the suitability of its products for any particular purpose, nor does **onsemi** assume any liability arising out of the application or use of any product or circuit, and specifically disclaims any and all liability, including without limitation special, consequential or incidental damages. **onsemi** does not convey any license under its patent rights nor the rights of others.

onsemi, **Onsemi**, and other names, marks, and brands are registered and/or common law trademarks of Semiconductor Components Industries, LLC dba "**onsemi**" or its affiliates and/or subsidiaries in the United States and/or other countries. **onsemi** owns the rights to a number of patents, trademarks, copyrights, trade secrets, and other intellectual property. A listing of **onsemi**'s product/patent coverage may be accessed at www.onsemi.com/site/pdf/Patent-Marking.pdf. **onsemi** reserves the right to make changes at any time to any products or information herein, without notice. The information herein is provided "as-is" and **onsemi** makes no warranty, representation or guarantee regarding the accuracy of the information, product features, availability, functionality, or suitability of its products for any particular purpose, nor does **onsemi** assume any liability arising out of the application or use of any product or circuit, and specifically disclaims any and all liability, including without limitation special, consequential or incidental damages. Buyer is responsible for its products and applications using **onsemi** products, including compliance with all laws, regulations and safety requirements or standards, regardless of any support or applications information provided by **onsemi**. "Typical" parameters which may be provided in **onsemi** data sheets and/or specifications can and do vary in different applications and actual performance may vary over time. All operating parameters, including "Typicals" must be validated for each customer application by customer's technical experts. **onsemi** does not convey any license under any of its intellectual property rights nor the rights of others. **onsemi** products are not designed, intended, or authorized for use as a critical component in life support systems or any FDA Class 3 medical devices or medical devices with a same or similar classification in a foreign jurisdiction or any devices intended for implantation in the human body. Should Buyer purchase or use **onsemi** products for any such unintended or unauthorized application, Buyer shall indemnify and hold **onsemi** and its officers, employees, subsidiaries, affiliates, and distributors harmless against all claims, costs, damages, and expenses, and reasonable attorney fees arising out of, directly or indirectly, any claim of personal injury or death associated with such unintended or unauthorized use, even if such claim alleges that **onsemi** was negligent regarding the design or manufacture of the part. **onsemi** is an Equal Opportunity/Affirmative Action Employer. This literature is subject to all applicable copyright laws and is not for resale in any manner.

ADDITIONAL INFORMATION

TECHNICAL PUBLICATIONS:

Technical Library: www.onsemi.com/design/resources/technical-documentation
onsemi Website: www.onsemi.com

ONLINE SUPPORT: www.onsemi.com/support

For additional information, please contact your local Sales Representative at www.onsemi.com/support/sales

Looking for pricing, stock, or lifecycle information?

Click below to explore more details on WIN SOURCE:

 [View NCV57080ADR2G on WIN SOURCE](#)

 [ON Semiconductor](#) Information

Optimize Your Supply Chain with WIN SOURCE Solutions

-  Global Sourcing Solution
-  Obsolete Management
-  Cost Control Management
-  Shortage Management
-  Alternative Solution
-  Excess Inventory Management