



**THE DATASHEET OF  
TIBPAL20R8-7CFN**



**TIBPAL20L8-7C, TIBPAL20R4-7C, TIBPAL20R6-7C, TIBPAL20R8-7C**  
**TIBPAL20L8-10M, TIBPAL20R4-10M, TIBPAL20R6-10M, TIBPAL20R8-10M**  
**HIGH-PERFORMANCE *IMPACT-X*<sup>TM</sup> PAL<sup>®</sup> CIRCUITS**

SRPS005D – D3307, OCTOBER 1989 – REVISED NOVEMBER 1995

- **High-Performance Operation:**
  - $f_{max}$  (no feedback)
    - TIBPAL20R' -7C Series . . . 100 MHz
    - TIBPAL20R' -10M Series . . . 62.5 MHz
  - $f_{max}$  (internal feedback)
    - TIBPAL20R' -7C Series . . . 100 MHz
    - TIBPAL20R' -10M Series . . . 62.5 MHz
  - $f_{max}$  (external feedback)
    - TIBPAL20R' -7C Series . . . 74 MHz
    - TIBPAL20R' -10M Series . . . 50 MHz
  - Propagation Delay
    - TIBPAL20L8-7C Series . . . 7 ns Max
    - TIBPAL20L8-10M Series . . . 10 ns Max
- **Functionally Equivalent, but Faster Than Existing 24-Pin PLD Circuits**
- **Preload Capability on Output Registers Simplifies Testing**
- **Power-Up Clear on Registered Devices (All Register Outputs are Set Low, but Voltage Levels at the Output Pins Go High)**
- **Package Options Include Both Plastic and Ceramic Chip Carriers in Addition to Plastic and Ceramic DIPs**
- **Security Fuse Prevents Duplication**
- **Dependable Texas Instruments Quality and Reliability**

DEVICE	I INPUTS	3-STATE O OUTPUTS	REGISTERED Q OUTPUTS	I/O PORTS
PAL20L8	14	2	0	6
PAL20R4	12	0	4 (3-state buffers)	4
PAL20R6	12	0	6 (3-state buffers)	2
PAL20R8	12	0	8 (3-state buffers)	0

**description**

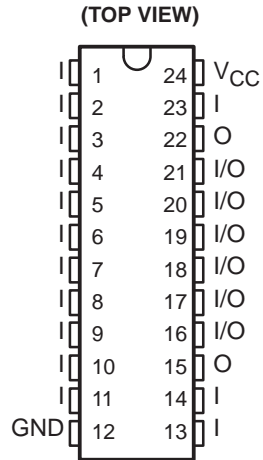
These programmable array logic devices feature high speed and functional equivalency when compared with currently available devices. These *IMPACT-X*<sup>TM</sup> circuits combine the latest Advanced Low-Power Schottky technology with proven titanium-tungsten fuses to provide reliable, high-performance substitutes for conventional TTL logic. Their easy programmability allows for quick design of custom functions and typically results in a more compact circuit board. In addition, chip carriers are available for further reduction in board space.

All of the register outputs are set to a low level during power-up. Extra circuitry has been provided to allow loading of each register asynchronously to either a high or low state. This feature simplifies testing because the registers can be set to an initial state prior to executing the test sequence.

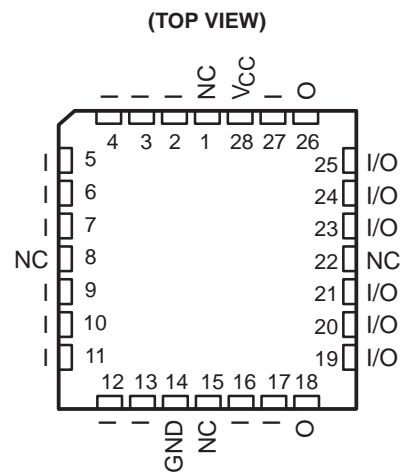
The TIBPAL20' C series is characterized from 0°C to 75°C. The TIBPAL20' M series is characterized for operation over the full military temperature range of -55°C to 125°C.

These devices are covered by U.S. Patent 4,410,987. *IMPACT-X* is a trademark of Texas Instruments Incorporated. PAL is a registered trademark of Advanced Micro Devices Inc.

**TIBPAL20L8'**  
**C SUFFIX . . . JT OR NT PACKAGE**  
**M SUFFIX . . . JT PACKAGE**



**TIBPAL20L8'**  
**C SUFFIX . . . FN PACKAGE**  
**M SUFFIX . . . FK PACKAGE**



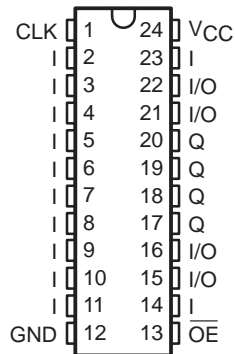
NC – No internal connection  
 Pin assignments in operating mode

PRODUCTION DATA information is current as of publication date. Products conform to specifications per the terms of Texas Instruments standard warranty. Production processing does not necessarily include testing of all parameters.

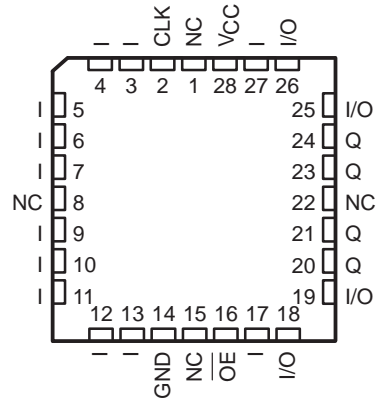


**TIBPAL20R4-7C, TIBPAL20R6-7C, TIBPAL20R8-7C**  
**TIBPAL20R4-10M, TIBPAL20R6-10M, TIBPAL20R8-10M**  
**HIGH-PERFORMANCE *IMPACT-X*™ *PAL*® CIRCUITS**  
 SRPS005D – D3307, OCTOBER 1989 – REVISED NOVEMBER 1995

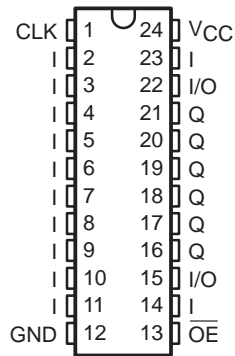
**TIBPAL20R4'**  
**C SUFFIX ... JT OR NT PACKAGE**  
**M SUFFIX ... JT PACKAGE**  
**(TOP VIEW)**



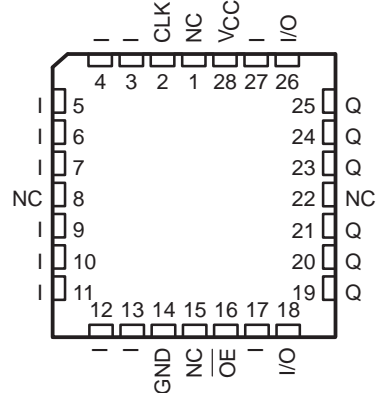
**TIBPAL20R4'**  
**C SUFFIX ... FN PACKAGE**  
**M SUFFIX ... FK PACKAGE**  
**(TOP VIEW)**



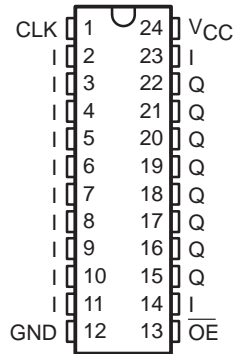
**TIBPAL20R6'**  
**C SUFFIX ... JT OR NT PACKAGE**  
**M SUFFIX ... JT PACKAGE**  
**(TOP VIEW)**



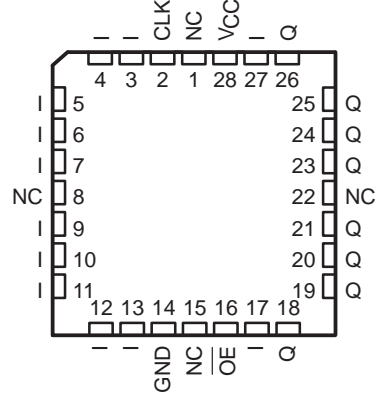
**TIBPAL20R6'**  
**C SUFFIX ... FN PACKAGE**  
**M SUFFIX ... FK PACKAGE**  
**(TOP VIEW)**



**TIBPAL20R8'**  
**C SUFFIX ... JT OR NT PACKAGE**  
**M SUFFIX ... JT PACKAGE**  
**(TOP VIEW)**



**TIBPAL20R8'**  
**C SUFFIX ... FN PACKAGE**  
**M SUFFIX ... FK PACKAGE**  
**(TOP VIEW)**

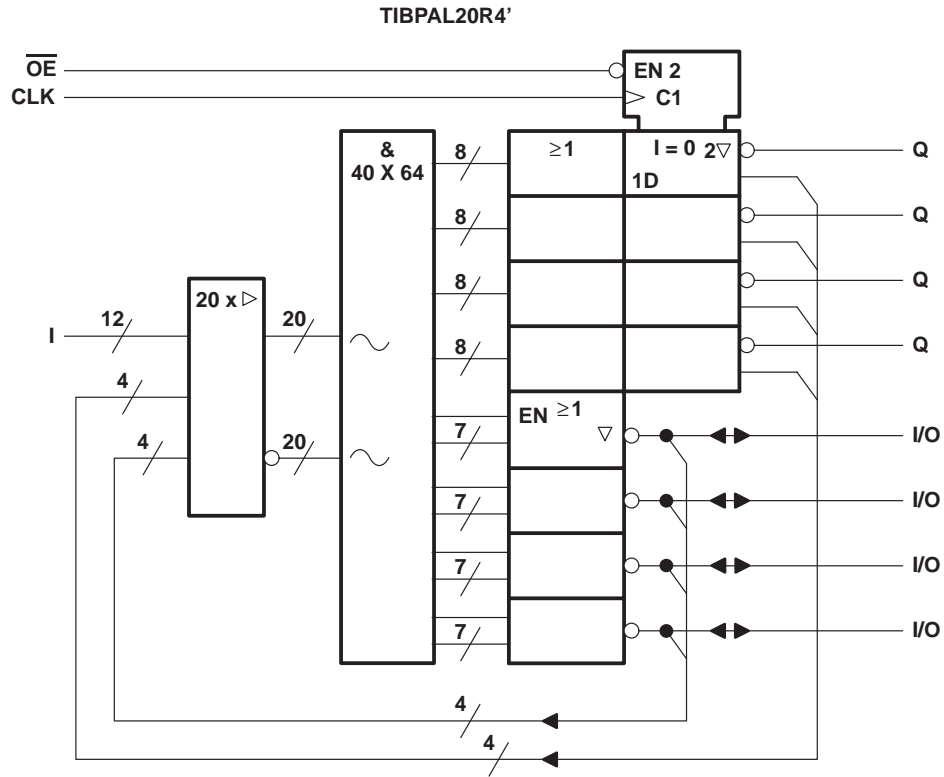
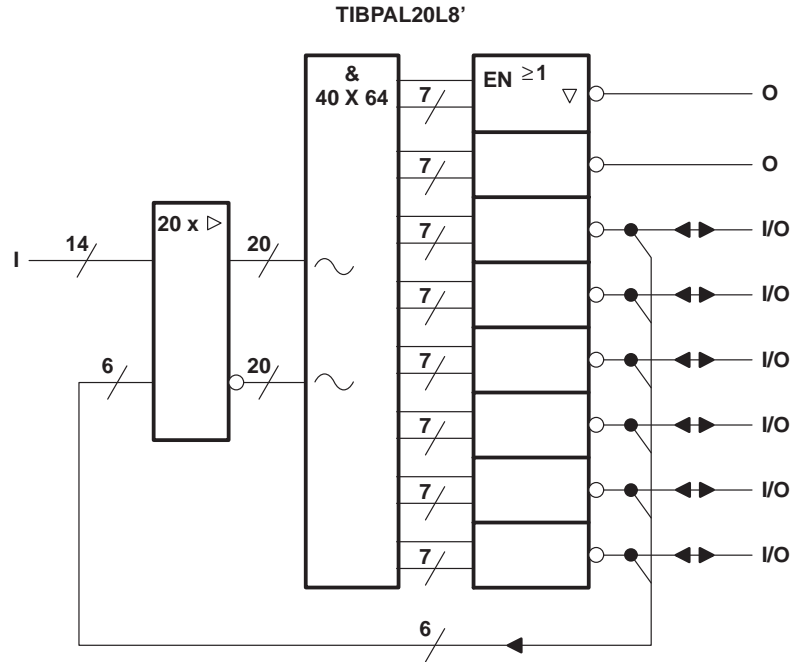


Pin assignments in operating mode

NC – No internal connection



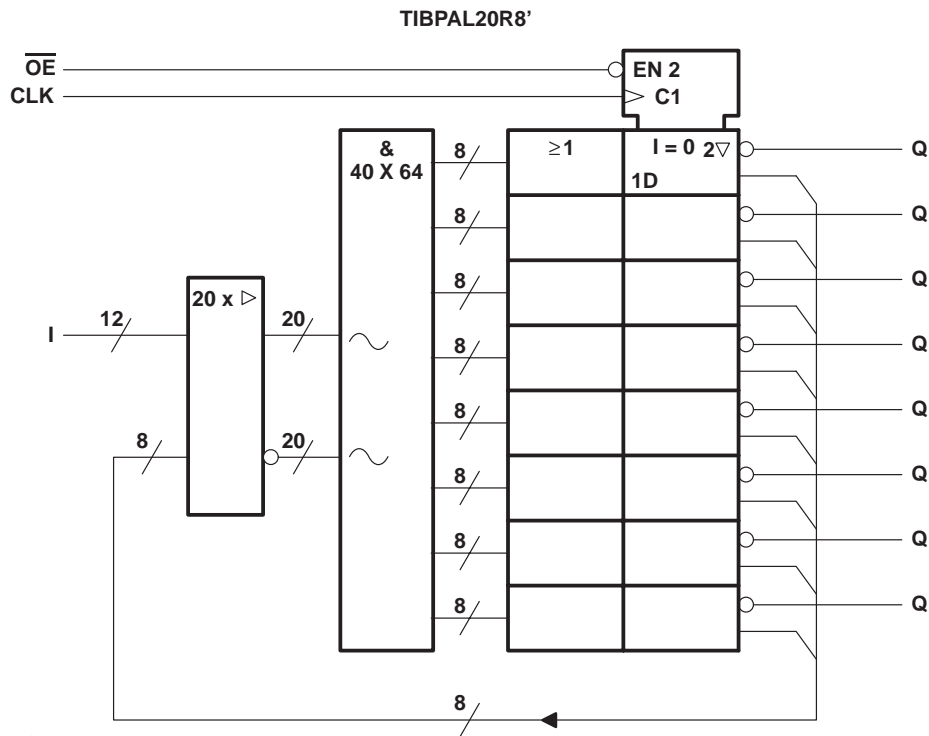
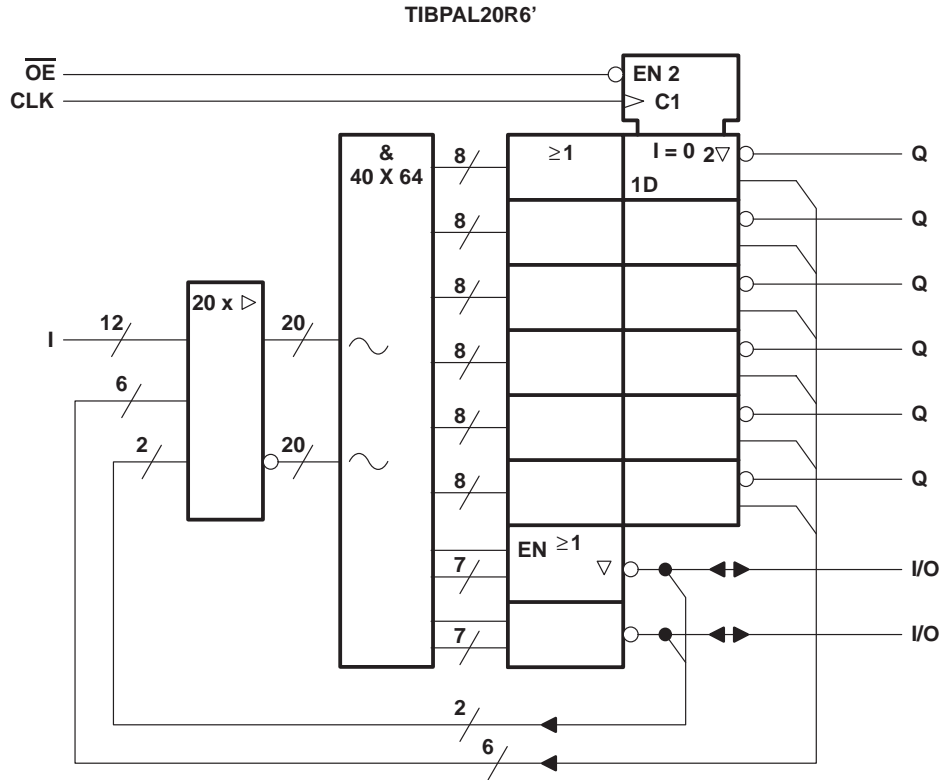
functional block diagrams (positive logic)



~ denotes fused inputs

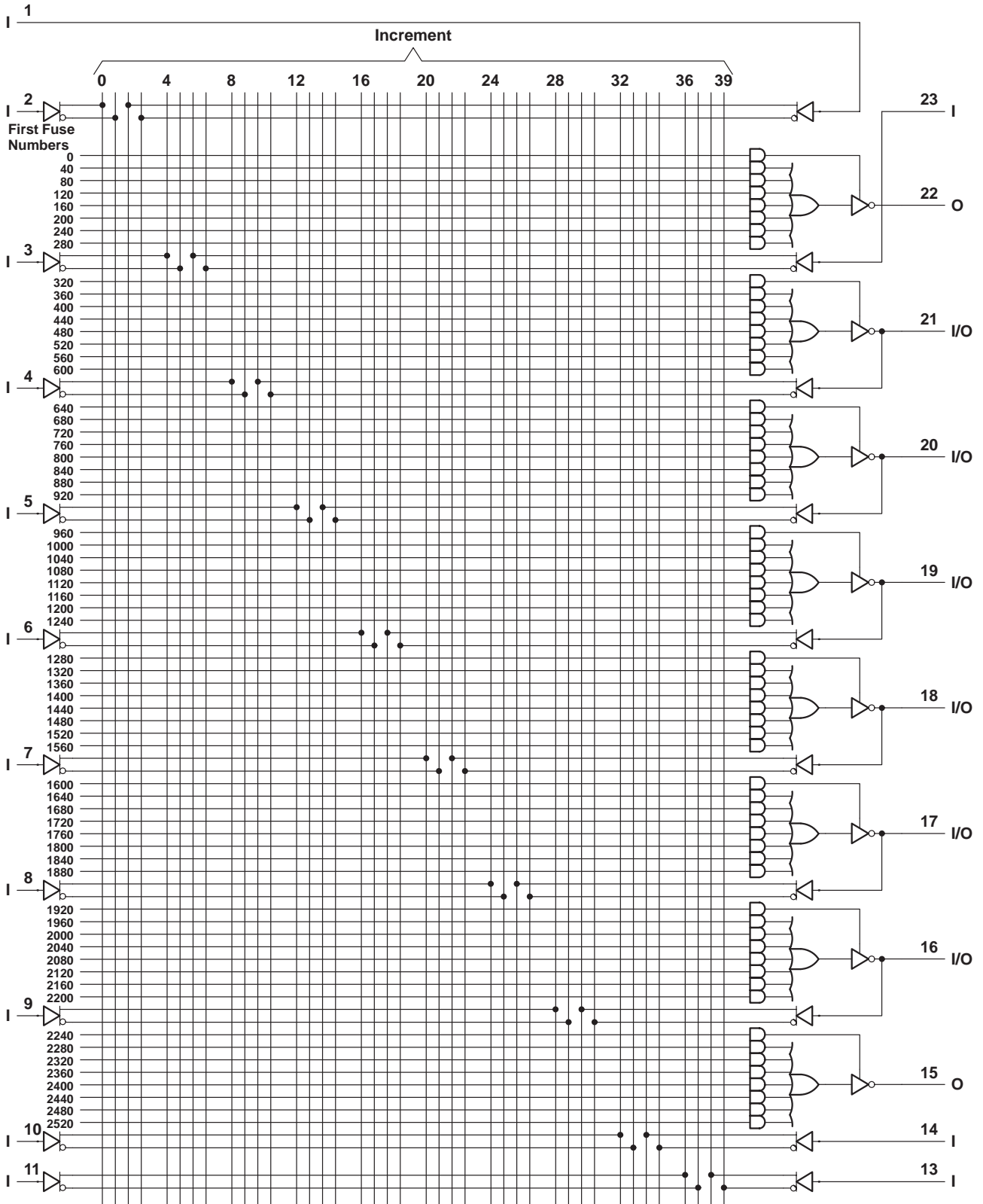
TIBPAL20R6-7C, TIBPAL20R8-7C  
 TIBPAL20R6-10M, TIBPAL20R8-10M  
 HIGH-PERFORMANCE *IMPACT-X*™ PAL® CIRCUITS  
 SRPS005D – D3307, OCTOBER 1989 – REVISED NOVEMBER 1995

functional block diagrams (positive logic)



~ denotes fused inputs

logic diagram (positive logic)

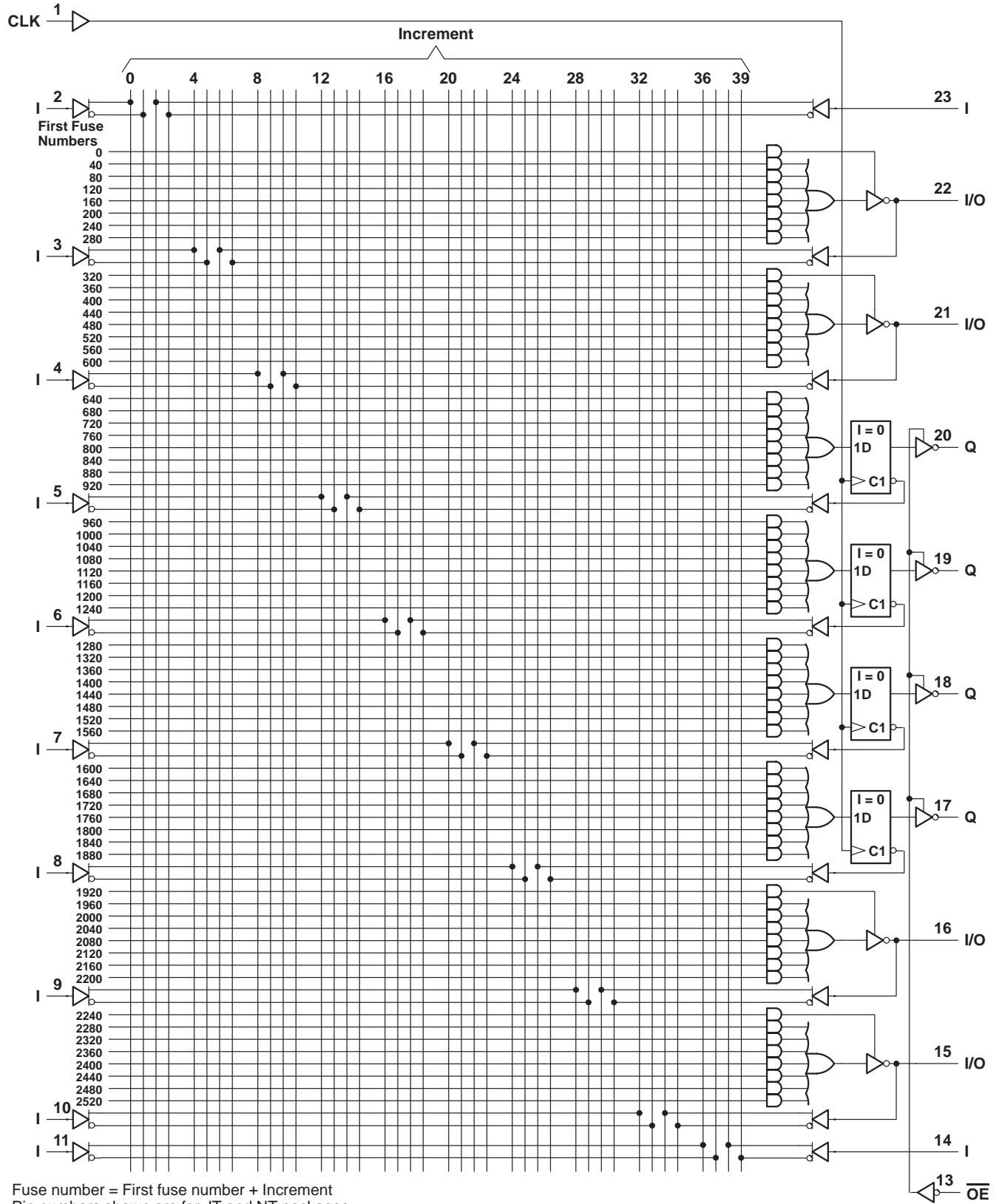


Fuse number = First fuse number + Increment  
Pin numbers shown are for JT and NT packages.



TIBPAL20R4-7C  
 TIBPAL20R4-10M  
 HIGH-PERFORMANCE *IMPACT-X*™ PAL® CIRCUITS  
 SRPS005D – D3307, OCTOBER 1989 – REVISED NOVEMBER 1995

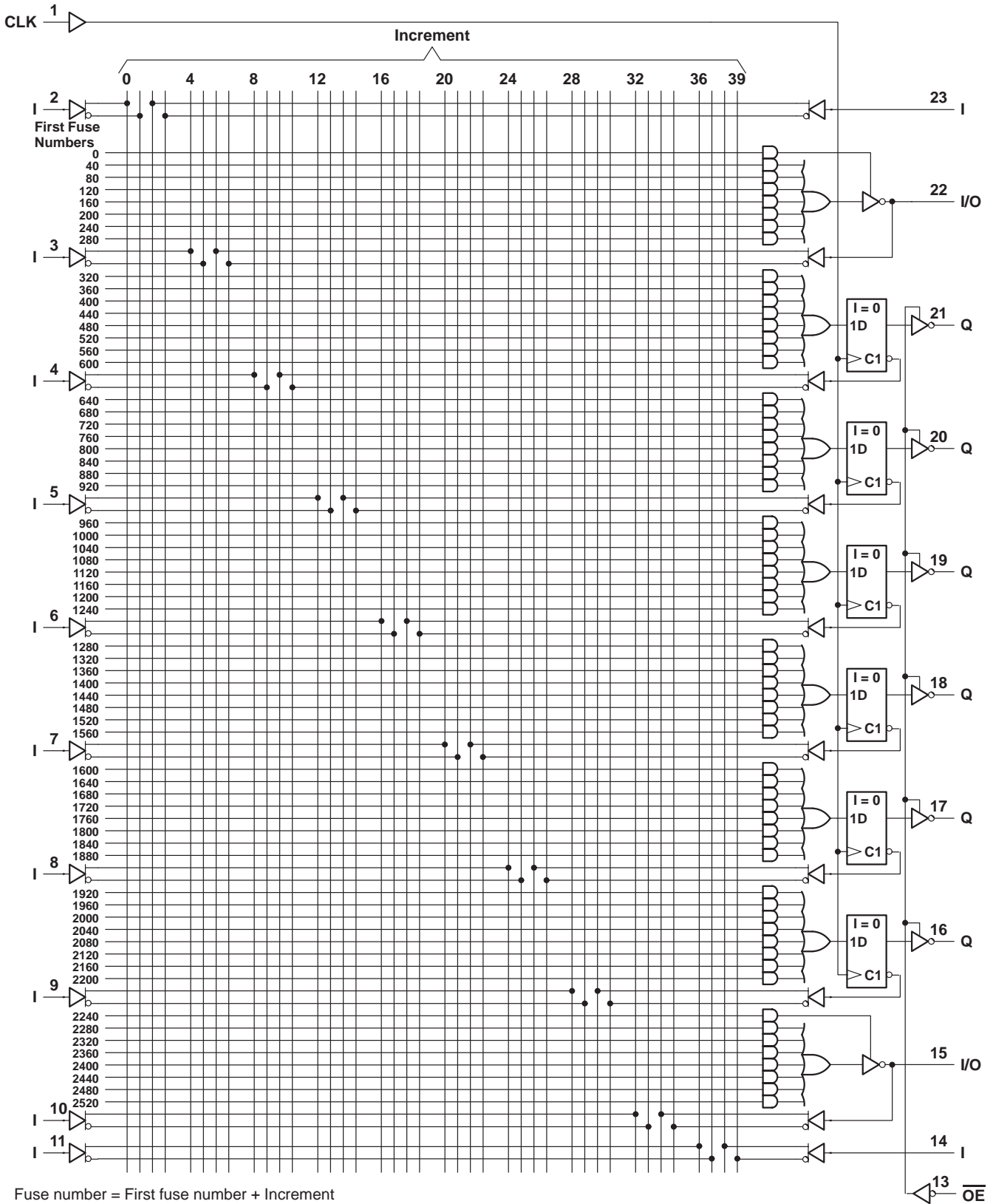
logic diagram (positive logic)



Fuse number = First fuse number + Increment  
 Pin numbers shown are for JT and NT packages.



logic diagram (positive logic)

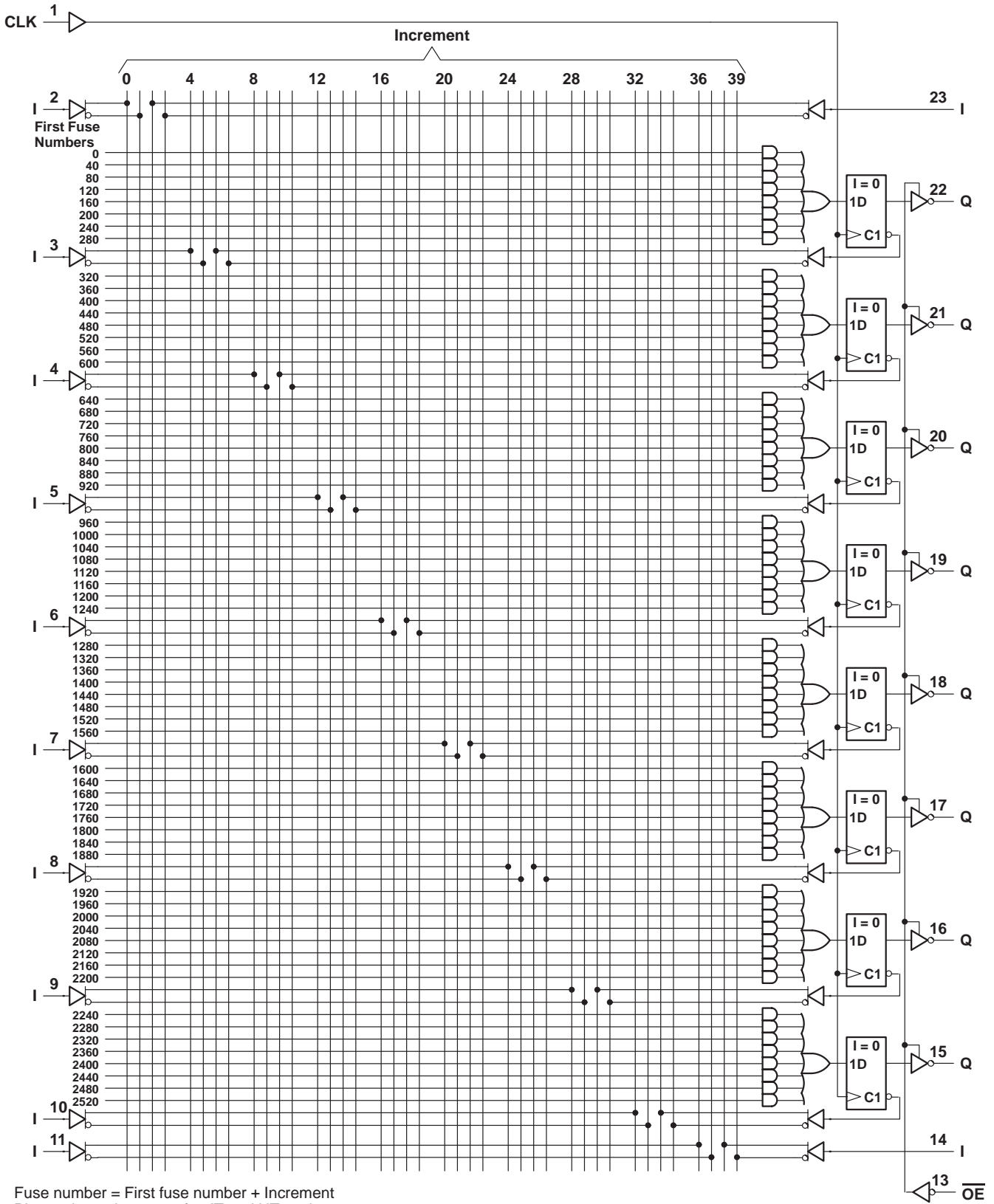


Fuse number = First fuse number + Increment  
Pin numbers shown are for JT and NT packages.



**TIBPAL20R8-7C**  
**TIBPAL20R8-10M**  
**HIGH-PERFORMANCE *IMPACT-X*™ PAL® CIRCUITS**  
 SRPS005D – D3307, OCTOBER 1989 – REVISED NOVEMBER 1995

**logic diagram (positive logic)**



Fuse number = First fuse number + Increment  
 Pin numbers shown are for JT and NT packages.



# TIBPAL20L8-7C, TIBPAL20R4-7C, TIBPAL20R6-7C, TIBPAL20R8-7C HIGH-PERFORMANCE *IMPACT-X*™ *PAL*® CIRCUITS

SRPS005D – D3307, OCTOBER 1989 – REVISED NOVEMBER 1995

## absolute maximum ratings over operating free-air temperature range (unless otherwise noted)

Supply voltage, $V_{CC}$ (see Note 1) .....	7 V
Input voltage (see Note 1) .....	5.5 V
Voltage applied to disabled output (see Note 1) .....	5.5 V
Operating free-air temperature range .....	0°C to 75°C
Storage temperature range .....	–65°C to 150°C

NOTE 1: These ratings apply except for programming pins during a programming cycle.

## recommended operating conditions

		MIN	NOM	MAX	UNIT
$V_{CC}$	Supply voltage	4.75	5	5.25	V
$V_{IH}$	High-level input voltage (see Note 2)	2		5.5	V
$V_{IL}$	Low-level input voltage (see Note 2)			0.8	V
$I_{OH}$	High-level output current			–3.2	mA
$I_{OL}$	Low-level output current			24	mA
$f_{clock}^\dagger$	Clock frequency	0		100	MHz
$t_w^\dagger$	Pulse duration, clock (see Note 2)	High	5		ns
		Low	5		
$t_{su}^\dagger$	Setup time, input or feedback before clock $\uparrow$	7			ns
$t_h^\dagger$	Hold time, input or feedback after clock $\uparrow$	0			ns
$T_A$	Operating free-air temperature	0	25	75	°C

$^\dagger f_{clock}$ ,  $t_w$ ,  $t_{su}$ , and  $t_h$  do not apply for TIBPAL20L8'.

NOTE 2: These are absolute voltage levels with respect to the ground pin of the device and include all overshoots due to system and/or tester noise. Testing these parameters should not be attempted without suitable equipment.



# TIBPAL20L8-7C, TIBPAL20R4-7C, TIBPAL20R6-7C, TIBPAL20R8-7C HIGH-PERFORMANCE *IMPACT-X*™ *PAL*® CIRCUITS

SRPS005D – D3307, OCTOBER 1989 – REVISED NOVEMBER 1995

## electrical characteristics over recommended operating free-air temperature range

PARAMETER	TEST CONDITIONS		MIN	TYP†	MAX	UNIT
$V_{IK}$	$V_{CC} = 4.75\text{ V}$ ,	$I_I = -18\text{ mA}$		-0.8	-1.5	V
$V_{OH}$	$V_{CC} = 4.75\text{ V}$ ,	$I_{OH} = -3.2\text{ mA}$	2.4	3.2		V
$V_{OL}$	$V_{CC} = 4.75\text{ V}$ ,	$I_{OL} = 24\text{ mA}$		0.3	0.5	V
$I_{OZH}‡$	$V_{CC} = 5.25\text{ V}$ ,	$V_O = 2.7\text{ V}$			100	$\mu\text{A}$
$I_{OZL}‡$	$V_{CC} = 5.25\text{ V}$ ,	$V_O = 0.4\text{ V}$			-100	$\mu\text{A}$
$I_I$	$V_{CC} = 5.25\text{ V}$ ,	$V_I = 5.5\text{ V}$			100	$\mu\text{A}$
$I_{IH}‡$	$V_{CC} = 5.25\text{ V}$ ,	$V_I = 2.7\text{ V}$			25	$\mu\text{A}$
$I_{IL}‡$	$V_{CC} = 5.25\text{ V}$ ,	$V_I = 0.4\text{ V}$		-80	-250	$\mu\text{A}$
$I_{OS}§$	$V_{CC} = 5.25\text{ V}$ ,	$V_O = 0.5\text{ V}$	-30	-70	-130	mA
$I_{CC}$	$V_{CC} = 5.25\text{ V}$ ,	$V_I = 0$ , Outputs open		150	210	mA
$C_i$	$f = 1\text{ MHz}$ ,	$V_I = 2\text{ V}$		5		pF
$C_o$	$f = 1\text{ MHz}$ ,	$V_O = 2\text{ V}$		6		pF
$C_{clk}$	$f = 1\text{ MHz}$ ,	$V_{CLK} = 2\text{ V}$		6		pF

## switching characteristics over recommended ranges of supply voltage and operating free-air temperature (unless otherwise noted)

PARAMETER	FROM (INPUT)	TO (OUTPUT)	TEST CONDITION	MIN	TYP†	MAX	UNIT	
$f_{max}¶$	without feedback		R1 = 200 $\Omega$ , R2 = 390 $\Omega$ , See Figure 6	100			MHz	
	with internal feedback (counter configuration)			100				
	with external feedback			74				
$t_{pd}$	I, I/O	O, I/O		1 or 2 outputs switching	3	5.5	7	ns
				8 outputs switching	3	6	7.5	
$t_{pd}$	CLK $\uparrow$	Q			2	4	6.5	ns
$t_{pd}^\#$	CLK $\uparrow$	Feedback input					3	ns
$t_{en}$	OE $\downarrow$	Q				4	7.5	ns
$t_{dis}$	OE $\uparrow$	Q				4	7.5	ns
$t_{en}$	I, I/O	O, I/O				6	9	ns
$t_{dis}$	I, I/O	O, I/O			6	9	ns	
$t_{sk(o)}  $	Skew between registered outputs				0.5		ns	

† All typical values are at  $V_{CC} = 5\text{ V}$ ,  $T_A = 25^\circ\text{C}$ .

‡ I/O leakage is the worst case of  $I_{OZL}$  and  $I_{IL}$  or  $I_{OZH}$  and  $I_{IH}$  respectively.

§ Not more than one output should be shorted at a time, and the duration of the short circuit should not exceed one second.  $V_O$  is set at 0.5 V to avoid test problems caused by test equipment ground degradation.

¶ See section for  $f_{max}$  specifications.

# This parameter applies to TIBPAL20R4' and TIBPAL20R6' only (see Figure 4 for illustration) and is calculated from the measured  $f_{max}$  with internal feedback in the counter configuration.

|| This parameter is the measurement of the difference between the fastest and slowest  $t_{pd}$  (CLK-to-Q) observed when multiple registered outputs are switching in the same direction.



**TIBPAL20L8-10M, TIBPAL20R4-10M, TIBPAL20R6-10M, TIBPAL20R8-10M**  
**HIGH-PERFORMANCE *IMPACT-X*™ *PAL*® CIRCUITS**

SRPS005D – D3307, OCTOBER 1989 – REVISED NOVEMBER 1995

**absolute maximum ratings over operating free-air temperature range (unless otherwise noted)**

Supply voltage, $V_{CC}$ (see Note 1) .....	7 V
Input voltage (see Note 1) .....	5.5 V
Voltage applied to disabled output (see Note 1) .....	5.5 V
Operating free-air temperature range .....	–55°C to 125°C
Storage temperature range .....	–65°C to 150°C

NOTE 1: These ratings apply except for programming pins during a programming cycle.

**recommended operating conditions**

		MIN	NOM	MAX	UNIT
$V_{CC}$	Supply voltage	4.5	5	5.5	V
$V_{IH}$	High-level input voltage	2		5.5	V
$V_{IL}$	Low-level input voltage			0.8	V
$I_{OH}$	High-level output current			–2	mA
$I_{OL}$	Low-level output current			12	mA
$f_{clock}^\dagger$	Clock frequency	0		62.5	MHz
$t_w^\dagger$	Pulse duration, clock (see Note 2)	High		8	ns
		Low		8	
$t_{su}^\dagger$	Setup time, input or feedback before clock $\uparrow$	10			ns
$t_h^\dagger$	Hold time, input or feedback after clock $\uparrow$	0			ns
$T_A$	Operating free-air temperature	–55	25	125	°C

$^\dagger f_{clock}$ ,  $t_w$ ,  $t_{su}$ , and  $t_h$  do not apply for TIBPAL20L8'.

NOTE 2: These are absolute voltage levels with respect to the ground pin of the device and include all overshoots due to system and/or tester noise. Testing these parameters should not be attempted without suitable equipment.



# TIBPAL20L8-10M, TIBPAL20R4-10M, TIBPAL20R6-10M, TIBPAL20R8-10M HIGH-PERFORMANCE *IMPACT-X*<sup>™</sup> *PAL*<sup>®</sup> CIRCUITS

SRPS005D – D3307, OCTOBER 1989 – REVISED NOVEMBER 1995

## electrical characteristics over recommended operating free-air temperature range

PARAMETER		TEST CONDITIONS		MIN	TYP†	MAX	UNIT
V <sub>IK</sub>		V <sub>CC</sub> = 4.5 V,	I <sub>I</sub> = -18 mA		-0.8	-1.5	V
V <sub>OH</sub>		V <sub>CC</sub> = 4.5 V,	I <sub>OH</sub> = -2 mA	2.4	3.2		V
V <sub>OL</sub>		V <sub>CC</sub> = 4.5 V,	I <sub>OL</sub> = 12 mA		0.3	0.5	V
I <sub>OZH</sub> ‡		V <sub>CC</sub> = 5.5 V,	V <sub>O</sub> = 2.7 V			20	μA
I <sub>OZL</sub> ‡		V <sub>CC</sub> = 5.5 V,	V <sub>O</sub> = 0.4 V			-0.1	mA
I <sub>I</sub>		V <sub>CC</sub> = 5.5 V,	V <sub>I</sub> = 5.5 V			1	mA
I <sub>IH</sub> ‡	I/O ports	V <sub>CC</sub> = 5.5 V,	V <sub>I</sub> = 2.7 V			100	μA
	All others					25	
I <sub>IL</sub> ‡		V <sub>CC</sub> = 5.5 V,	V <sub>I</sub> = 0.4 V		-0.08	-0.25	mA
I <sub>OS</sub> §		V <sub>CC</sub> = 5.5 V,	V <sub>O</sub> = 0.5 V	-30	-70	-130	mA
I <sub>CC</sub>		V <sub>CC</sub> = 5.5 V, V <sub>I</sub> = 0,	Outputs open OE = V <sub>IH</sub>		140	220	mA
C <sub>i</sub>		f = 1 MHz,	V <sub>I</sub> = 2 V		5		pF
C <sub>o</sub>		f = 1 MHz,	V <sub>O</sub> = 2 V		6		pF
C <sub>clk</sub>		f = 1 MHz,	V <sub>CLK</sub> = 2 V		6		pF

## switching characteristics over recommended ranges of supply voltage and operating free-air temperature (unless otherwise noted)

PARAMETER	FROM (INPUT)	TO (OUTPUT)	TEST CONDITION	MIN	TYP†	MAX	UNIT
f <sub>max</sub> ¶	without feedback		R1 = 390 Ω, R2 = 750 Ω, See Figure 6	62.5			MHz
	with internal feedback (counter configuration)			62.5			
	with external feedback			50			
t <sub>pd</sub>	I, I/O	O, I/O		1	6	10	ns
t <sub>pd</sub>	CLK↑	Q		1	4	10	ns
t <sub>pd</sub> #	CLK↑	Feedback input				5	ns
t <sub>en</sub>	OE↓	Q		1	4	10	ns
t <sub>dis</sub>	OE↑	Q		1	4	10	ns
t <sub>en</sub>	I, I/O	O, I/O		1	6	12	ns
t <sub>dis</sub>	I, I/O	O, I/O	1	6	10	ns	

† All typical values are at V<sub>CC</sub> = 5 V, T<sub>A</sub> = 25°C.

‡ I/O leakage is the worst case of I<sub>OZL</sub> and I<sub>IL</sub> or I<sub>OZH</sub> and I<sub>IH</sub> respectively.

§ Not more than one output should be shorted at a time, and the duration of the short circuit should not exceed one second. V<sub>O</sub> is set at 0.5 V to avoid test problems caused by test equipment ground degradation.

¶ See section for f<sub>max</sub> specifications. f<sub>max</sub> with external feedback is not production tested but is calculated from the equation found in the f<sub>max</sub> specification section.

# This parameter applies to TIBPAL20R4' and TIBPAL20R6' only (see Figure 4 for illustration) and is calculated from the measured f<sub>max</sub> with internal feedback in the counter configuration.



## programming information

Texas Instruments programmable logic devices can be programmed using widely available software and inexpensive device programmers.

Complete programming specifications, algorithms, and the latest information on hardware, software, and firmware are available upon request. Information on programmers capable of programming Texas Instruments programmable logic is also available, upon request, from the nearest TI field sales office, local authorized TI distributor, or by calling Texas Instruments at (214) 997-5666.

## preload procedure for registered outputs (see Figure 1 and Note 3)

The output registers can be preloaded to any desired state during device testing. This permits any state to be tested without having to step through the entire state-machine sequence. Each register is preloaded individually by following the steps given below.

- Step 1. With  $V_{CC}$  at 5 volts and Pin 1 at  $V_{IL}$ , raise Pin 13 to  $V_{IHH}$ .
- Step 2. Apply either  $V_{IL}$  or  $V_{IH}$  to the output corresponding to the register to be preloaded.
- Step 3. Pulse Pin 1, clocking in preload data.
- Step 4. Remove output voltage, then lower Pin 13 to  $V_{IL}$ . Preload can be verified by observing the voltage level at the output pin.

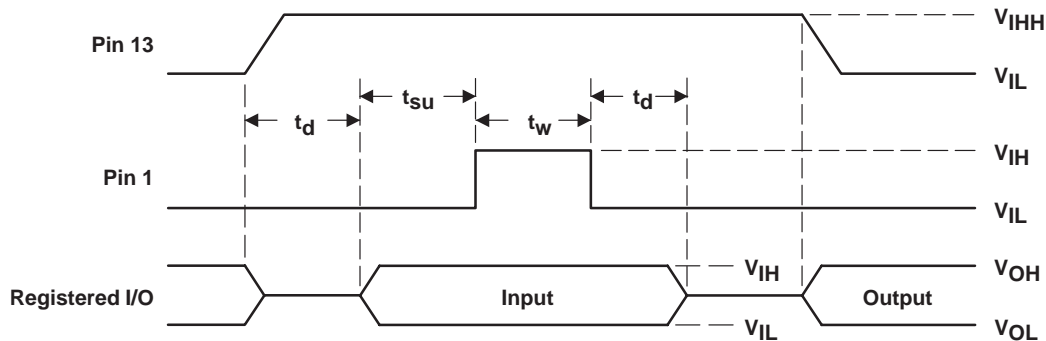
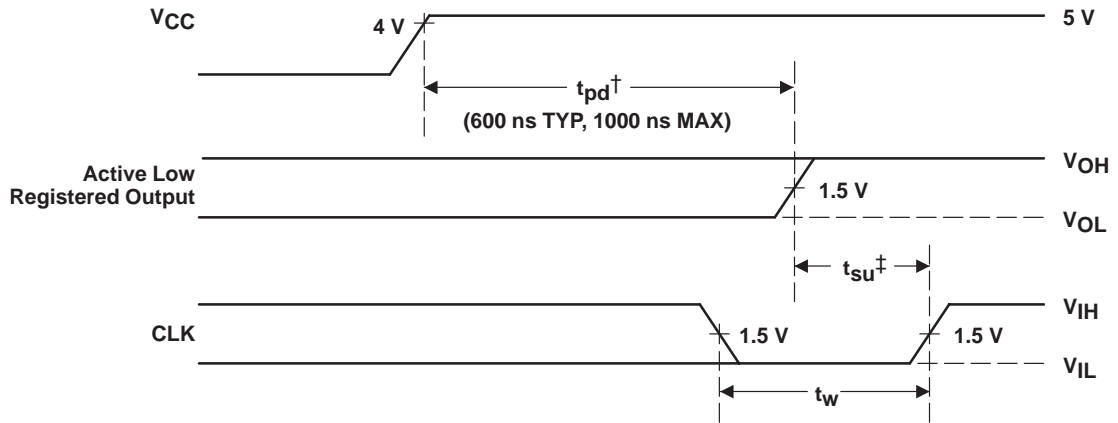


Figure 1. Preload Waveforms

NOTE 3:  $t_d = t_{su} = t_h = 100 \text{ ns to } 1000 \text{ ns}$   $V_{IHH} = 10.25 \text{ V to } 10.75 \text{ v}$

**power-up reset (see Figure 2)**

Following power up, all registers are reset to zero. This feature provides extra flexibility to the system designer and is especially valuable in simplifying state-machine initialization. To ensure a valid power-up reset, it is important that the rise of  $V_{CC}$  be monotonic. Following power-up reset, a low-to-high clock transition must not occur until all applicable input and feedback setup times are met.



† This is the power-up reset time and applies to registered outputs only. The values shown are from characterization data.  
 ‡ This is the setup time for input or feedback.

**Figure 2. Power-Up Reset Waveforms**

## $f_{\max}$ SPECIFICATIONS

### $f_{\max}$ without feedback, see Figure 3

In this mode, data is presented at the input to the flip-flop and clocked through to the Q output with no feedback. Under this condition, the clock period is limited by the sum of the data setup time and the data hold time ( $t_{su} + t_h$ ). However, the minimum  $f_{\max}$  is determined by the minimum clock period ( $t_{w\text{ high}} + t_{w\text{ low}}$ ).

Thus,  $f_{\max}$  without feedback =  $\frac{1}{(t_{w\text{ high}} + t_{w\text{ low}})}$  or  $\frac{1}{(t_{su} + t_h)}$ .

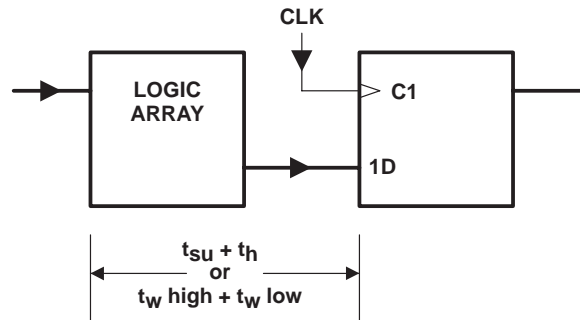


Figure 3.  $f_{\max}$  Without Feedback

### $f_{\max}$ with internal feedback, see Figure 4

This configuration is most popular in counters and on-chip state-machine designs. The flip-flop inputs are defined by the device inputs and flip-flop outputs. Under this condition, the period is limited by the internal delay from the flip-flop outputs through the internal feedback and logic array to the inputs of the next flip-flop.

Thus,  $f_{\max}$  with internal feedback =  $\frac{1}{(t_{su} + t_{pd\text{ CLK-to-FB}})}$ .

Where  $t_{pd\text{ CLK-to-FB}}$  is the deduced value of the delay from CLK to the input of the logic array.

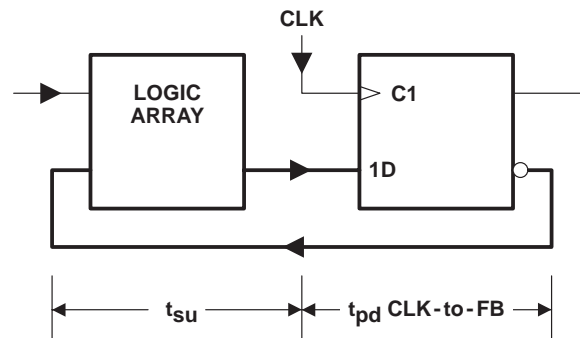


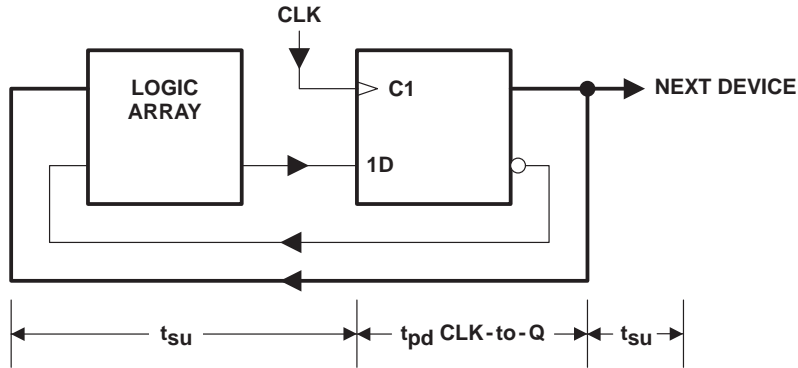
Figure 4.  $f_{\max}$  With Internal Feedback

**f<sub>max</sub> SPECIFICATIONS**

**f<sub>max</sub> with external feedback, see Figure 5**

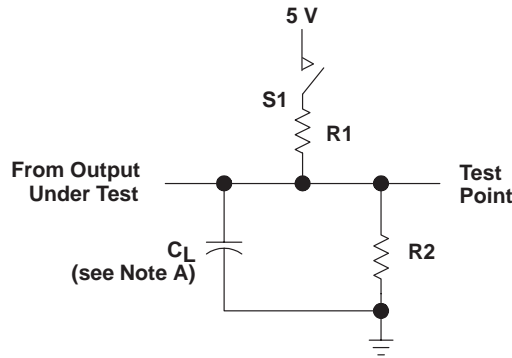
This configuration is a typical state-machine design with feedback signals sent off-chip. This external feedback could go back to the device inputs or to a second device in a multi-chip state machine. The slowest path defining the period is the sum of the clock-to-output time and the input setup time for the external signals (t<sub>su</sub> + t<sub>pd</sub> CLK-to-Q).

$$\text{Thus, } f_{\text{max}} \text{ with external feedback} = \frac{1}{(t_{\text{su}} + t_{\text{pd}} \text{ CLK-to-Q})}$$

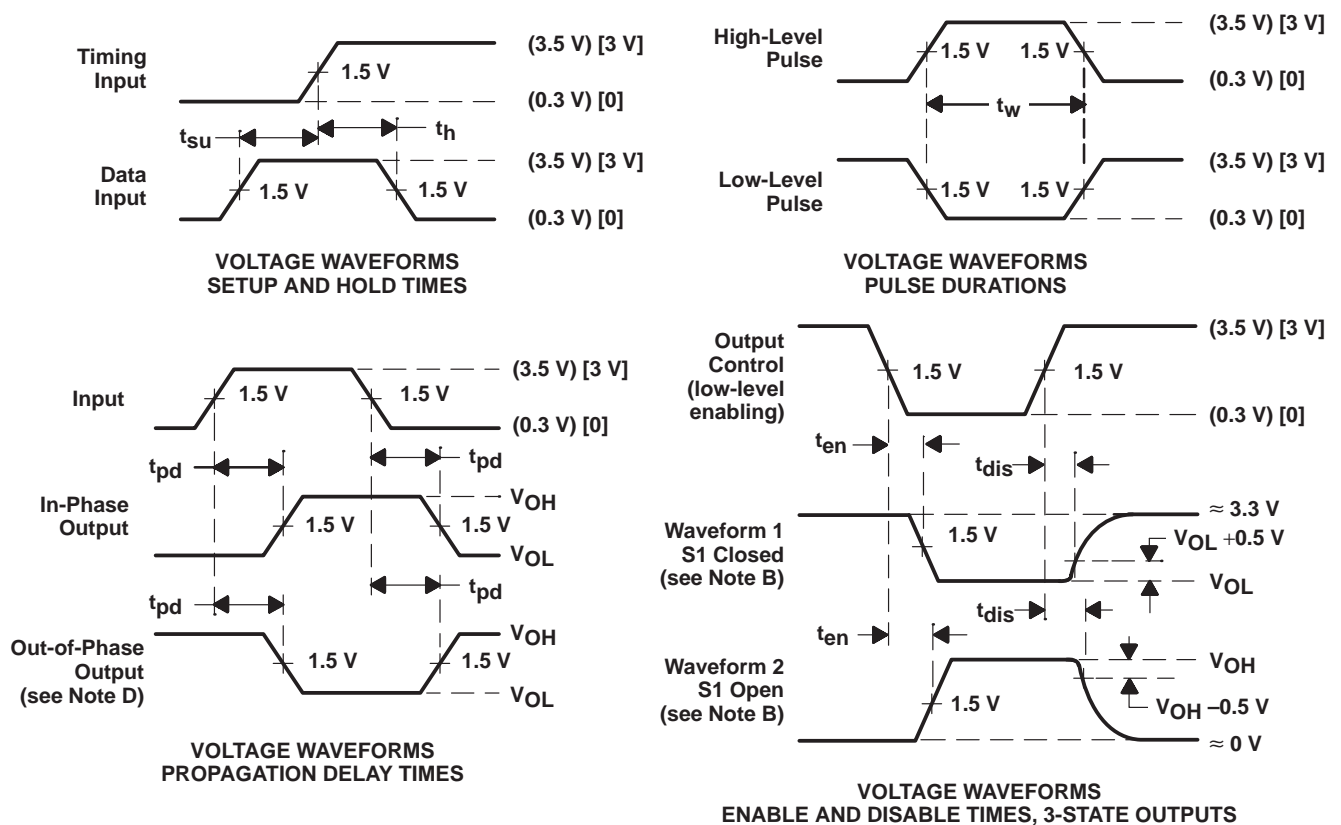


**Figure 5. f<sub>max</sub> With External Feedback**

PARAMETER MEASUREMENT INFORMATION



LOAD CIRCUIT FOR 3-STATE OUTPUTS



- NOTES: A.  $C_L$  includes probe and jig capacitance and is 50 pF for  $t_{pd}$  and  $t_{en}$ , 5 pF for  $t_{dis}$ .  
 B. Waveform 1 is for an output with internal conditions such that the output is low except when disabled by the output control. Waveform 2 is for an output with internal conditions such that the output is high except when disabled by the output control.  
 C. All input pulses have the following characteristics:  $PRR \leq 10$  MHz,  $t_r$  and  $t_f \leq 2$  ns, duty cycle = 50%. For C suffix, use the voltage levels indicated in parentheses ( ). For M suffix, use the voltage levels indicated in brackets [ ].  
 D. When measuring propagation delay times of 3-state outputs, switch S1 is closed.  
 E. Equivalent loads may be used for testing.

Figure 6. Load Circuit and Voltage Waveforms

TYPICAL CHARACTERISTICS

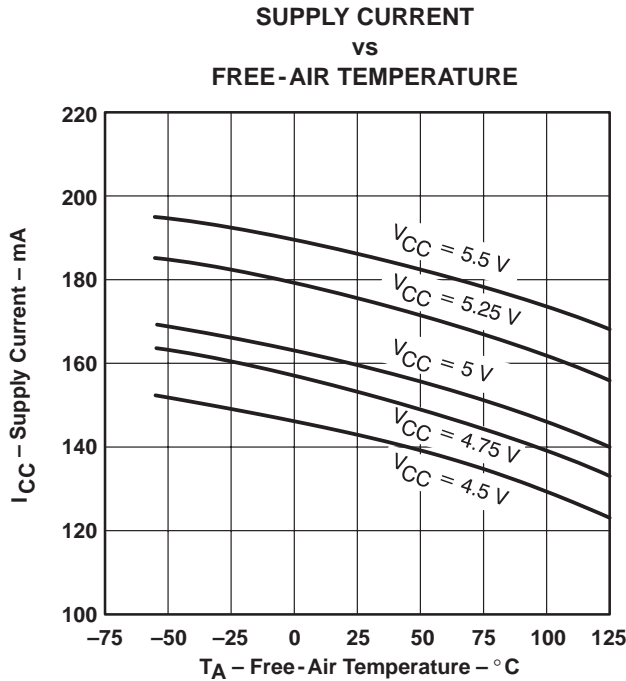


Figure 7

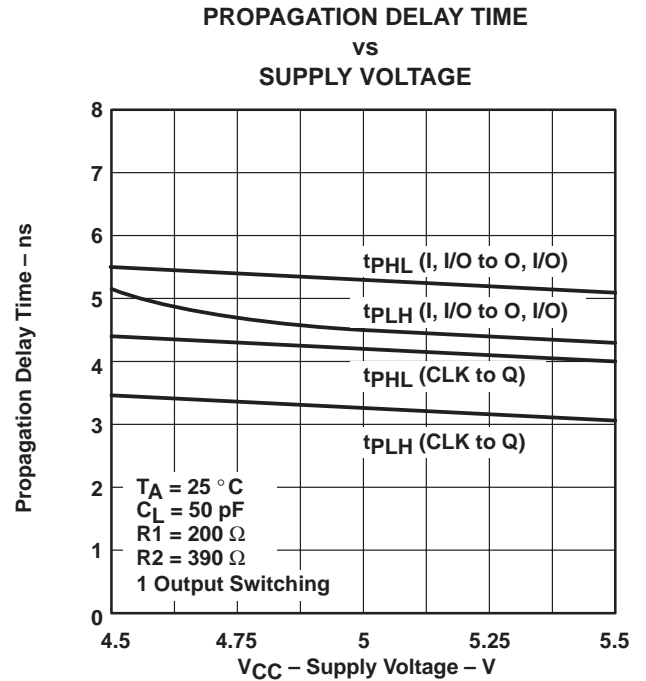


Figure 8

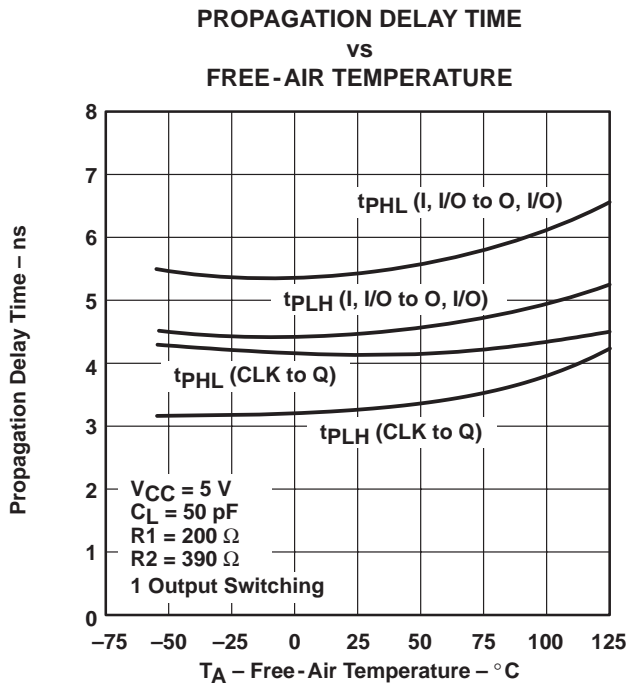


Figure 9

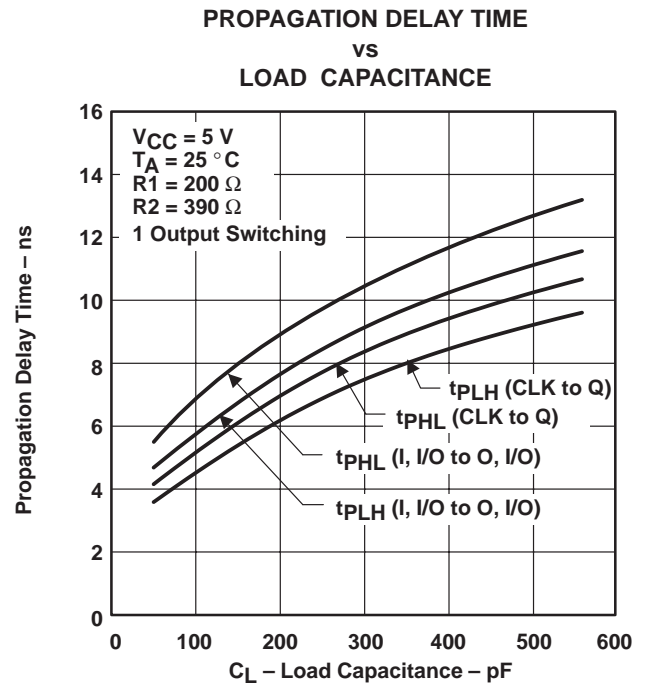


Figure 10

TYPICAL CHARACTERISTICS

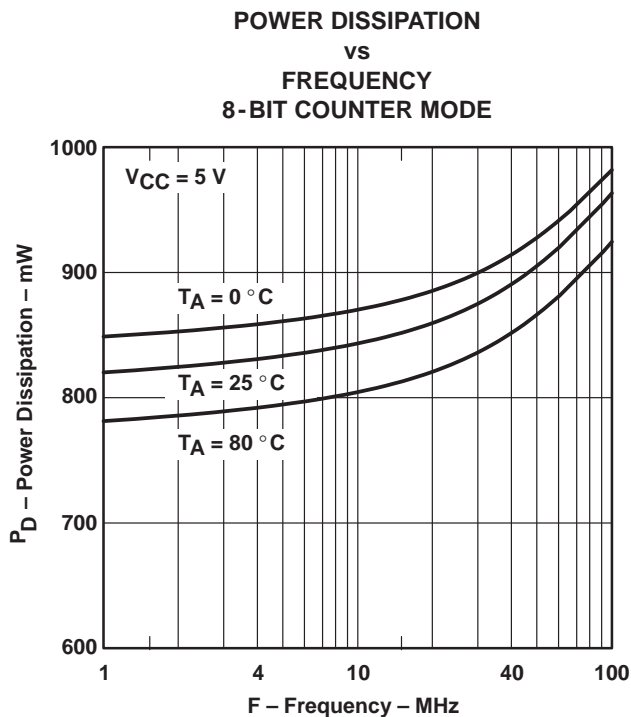


Figure 11

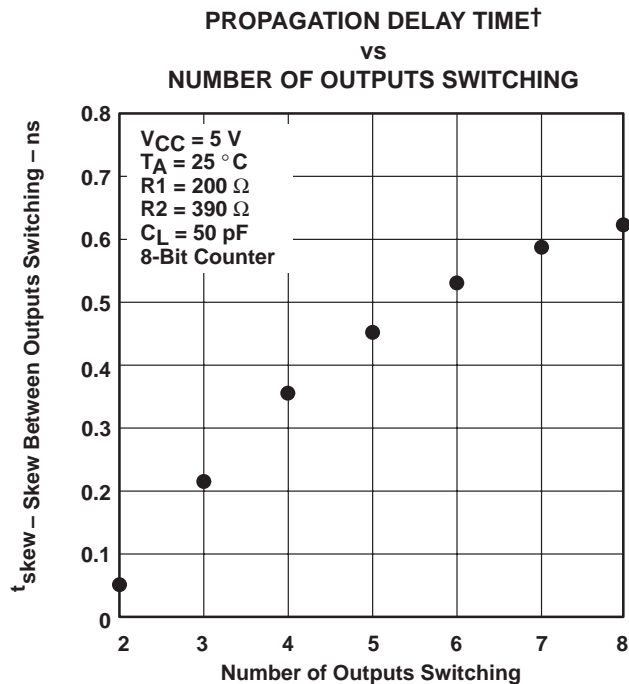


Figure 12

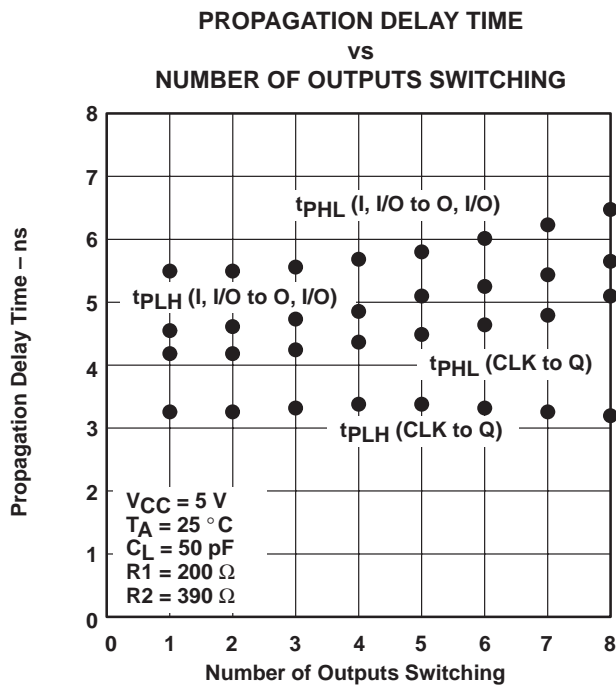


Figure 13

†Outputs switching in the same direction (tPLH compared to tPLH/tPHL to tPHL)

**PACKAGING INFORMATION**

Orderable Device	Status <sup>(1)</sup>	Package Type	Package Drawing	Pins	Package Qty	Eco Plan <sup>(2)</sup>	Lead/Ball Finish	MSL Peak Temp <sup>(3)</sup>
5962-87671153A	ACTIVE	LCCC	FK	28	1	TBD	POST-PLATE	N / A for Pkg Type
5962-8767115KA	ACTIVE	CFP	W	24	1	TBD	A42	N / A for Pkg Type
5962-8767115LA	ACTIVE	CDIP	JT	24	1	TBD	A42	N / A for Pkg Type
5962-87671163A	OBSOLETE	LCCC	FK	28		TBD	Call TI	Call TI
5962-8767116KA	OBSOLETE	CFP	W	24		TBD	Call TI	Call TI
5962-8767116LA	OBSOLETE	CDIP	JT	24		TBD	Call TI	Call TI
5962-87671173A	ACTIVE	LCCC	FK	28	1	TBD	POST-PLATE	N / A for Pkg Type
5962-8767117KA	ACTIVE	CFP	W	24	1	TBD	A42	N / A for Pkg Type
5962-8767117LA	ACTIVE	CDIP	JT	24	1	TBD	A42	N / A for Pkg Type
5962-87671183A	ACTIVE	LCCC	FK	28	1	TBD	POST-PLATE	N / A for Pkg Type
5962-8767118KA	ACTIVE	CFP	W	24	1	TBD	A42	N / A for Pkg Type
5962-8767118LA	ACTIVE	CDIP	JT	24	1	TBD	A42	N / A for Pkg Type
TIBPAL20L8-10MFKB	ACTIVE	LCCC	FK	28	1	TBD	POST-PLATE	N / A for Pkg Type
TIBPAL20L8-10MJTB	ACTIVE	CDIP	JT	24	1	TBD	A42	N / A for Pkg Type
TIBPAL20L8-10MWB	ACTIVE	CFP	W	24	1	TBD	A42	N / A for Pkg Type
TIBPAL20L8-7CFN	OBSOLETE	PLCC	FN	28		TBD	Call TI	Call TI
TIBPAL20L8-7CNT	OBSOLETE	PDIP	NT	24		TBD	Call TI	Call TI
TIBPAL20R4-10MFKB	ACTIVE	LCCC	FK	28	1	TBD	POST-PLATE	N / A for Pkg Type
TIBPAL20R4-10MJTB	ACTIVE	CDIP	JT	24	1	TBD	A42	N / A for Pkg Type
TIBPAL20R4-10MWB	ACTIVE	CFP	W	24	1	TBD	A42	N / A for Pkg Type
TIBPAL20R4-7CFN	OBSOLETE	PLCC	FN	28		TBD	Call TI	Call TI
TIBPAL20R4-7CNT	OBSOLETE	PDIP	NT	24		TBD	Call TI	Call TI
TIBPAL20R6-10MFKB	ACTIVE	LCCC	FK	28	1	TBD	POST-PLATE	N / A for Pkg Type
TIBPAL20R6-10MJTB	ACTIVE	CDIP	JT	24	1	TBD	A42	N / A for Pkg Type
TIBPAL20R6-10MWB	ACTIVE	CFP	W	24	1	TBD	A42	N / A for Pkg Type
TIBPAL20R6-7CFN	ACTIVE	PLCC	FN	28	37	TBD	CU	Level-1-220C-UNLIM
TIBPAL20R6-7CNT	ACTIVE	PDIP	NT	24	15	Pb-Free (RoHS)	CU NIPDAU	N / A for Pkg Type
TIBPAL20R8-10MFKB	OBSOLETE	LCCC	FK	28		TBD	Call TI	Call TI
TIBPAL20R8-10MJTB	OBSOLETE	CDIP	JT	24		TBD	Call TI	Call TI
TIBPAL20R8-10MWB	OBSOLETE	CFP	W	24		TBD	Call TI	Call TI
TIBPAL20R8-7CFN	ACTIVE	PLCC	FN	28	37	TBD	CU	Level-1-220C-UNLIM
TIBPAL20R8-7CNT	ACTIVE	PDIP	NT	24	15	Pb-Free (RoHS)	CU NIPDAU	N / A for Pkg Type

<sup>(1)</sup> The marketing status values are defined as follows:

**ACTIVE:** Product device recommended for new designs.

**LIFEBUY:** TI has announced that the device will be discontinued, and a lifetime-buy period is in effect.

**NRND:** Not recommended for new designs. Device is in production to support existing customers, but TI does not recommend using this part in a new design.

**PREVIEW:** Device has been announced but is not in production. Samples may or may not be available.

**OBSOLETE:** TI has discontinued the production of the device.

<sup>(2)</sup> Eco Plan - The planned eco-friendly classification: Pb-Free (RoHS), Pb-Free (RoHS Exempt), or Green (RoHS & no Sb/Br) - please check <http://www.ti.com/productcontent> for the latest availability information and additional product content details.

**TBD:** The Pb-Free/Green conversion plan has not been defined.

**Pb-Free (RoHS):** TI's terms "Lead-Free" or "Pb-Free" mean semiconductor products that are compatible with the current RoHS requirements for all 6 substances, including the requirement that lead not exceed 0.1% by weight in homogeneous materials. Where designed to be soldered at high temperatures, TI Pb-Free products are suitable for use in specified lead-free processes.

**Pb-Free (RoHS Exempt):** This component has a RoHS exemption for either 1) lead-based flip-chip solder bumps used between the die and package, or 2) lead-based die adhesive used between the die and leadframe. The component is otherwise considered Pb-Free (RoHS compatible) as defined above.

**Green (RoHS & no Sb/Br):** TI defines "Green" to mean Pb-Free (RoHS compatible), and free of Bromine (Br) and Antimony (Sb) based flame retardants (Br or Sb do not exceed 0.1% by weight in homogeneous material)

<sup>(3)</sup> MSL, Peak Temp. -- The Moisture Sensitivity Level rating according to the JEDEC industry standard classifications, and peak solder temperature.

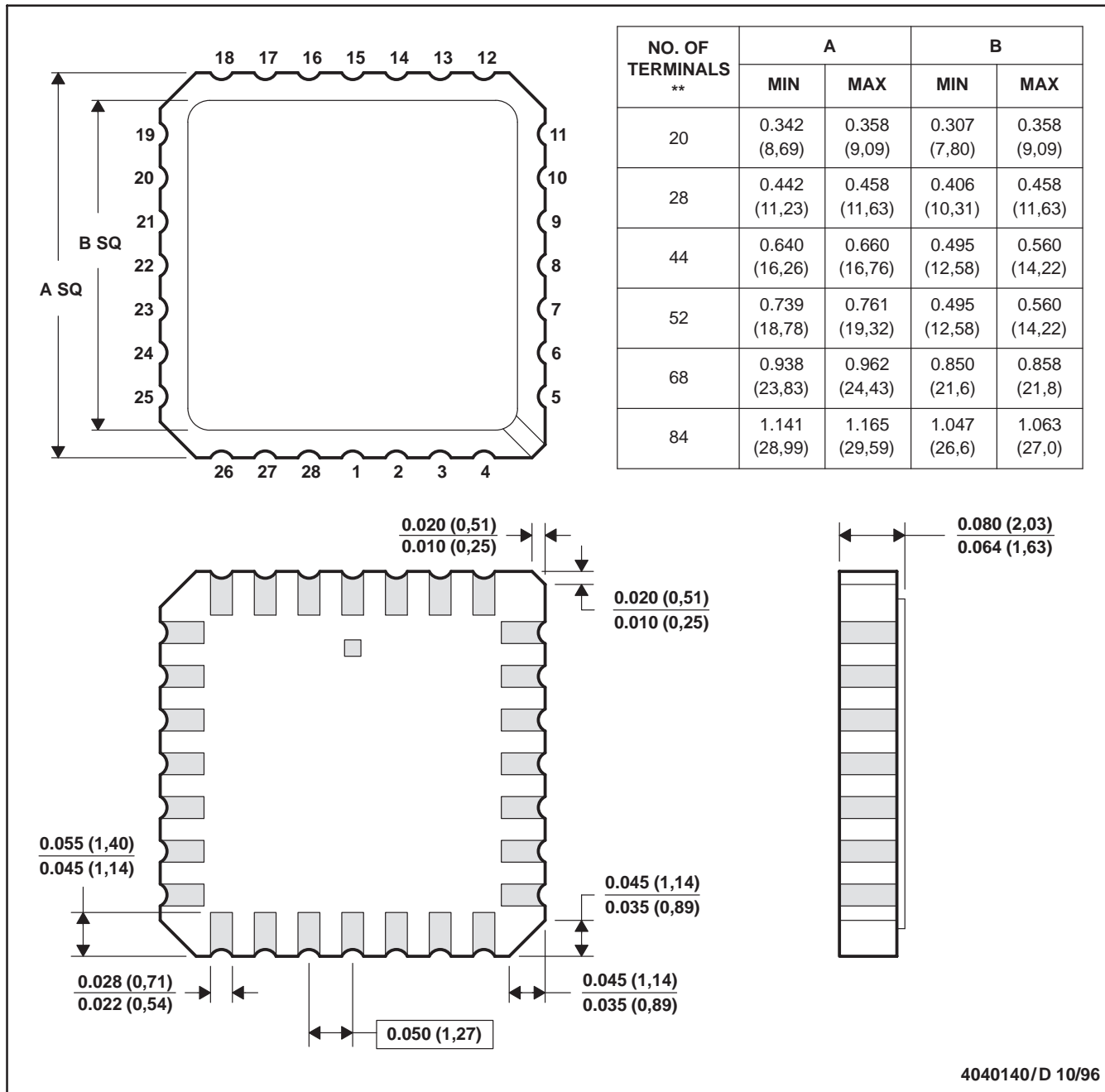
**Important Information and Disclaimer:**The information provided on this page represents TI's knowledge and belief as of the date that it is provided. TI bases its knowledge and belief on information provided by third parties, and makes no representation or warranty as to the accuracy of such information. Efforts are underway to better integrate information from third parties. TI has taken and continues to take reasonable steps to provide representative and accurate information but may not have conducted destructive testing or chemical analysis on incoming materials and chemicals. TI and TI suppliers consider certain information to be proprietary, and thus CAS numbers and other limited information may not be available for release.

In no event shall TI's liability arising out of such information exceed the total purchase price of the TI part(s) at issue in this document sold by TI to Customer on an annual basis.

FK (S-CQCC-N\*\*)

LEADLESS CERAMIC CHIP CARRIER

28 TERMINAL SHOWN

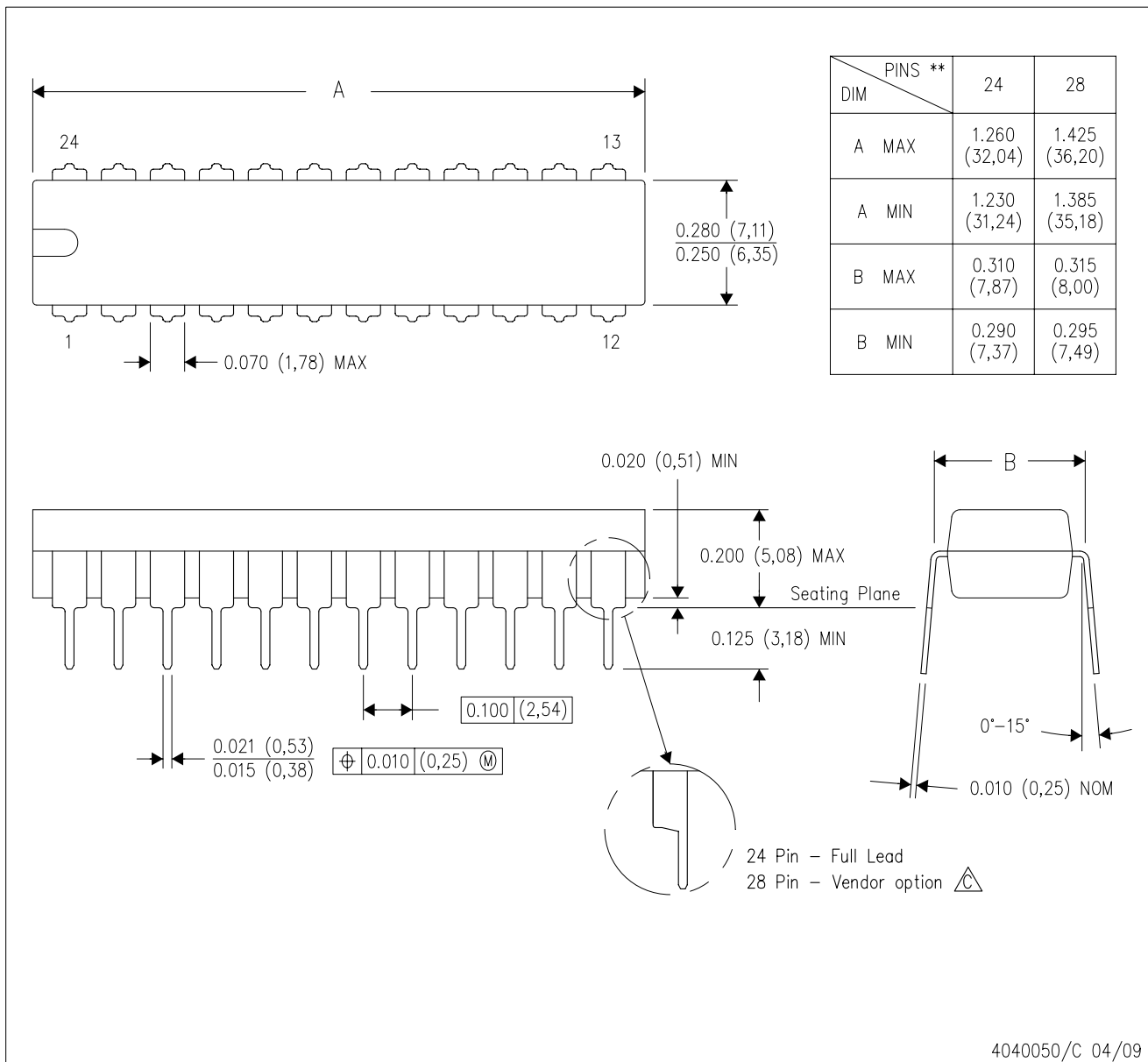



- NOTES:
- A. All linear dimensions are in inches (millimeters).
  - B. This drawing is subject to change without notice.
  - C. This package can be hermetically sealed with a metal lid.
  - D. The terminals are gold plated.
  - E. Falls within JEDEC MS-004

# MECHANICAL DATA

NT (R-PDIP-T\*\*) 24 PINS SHOWN

PLASTIC DUAL-IN-LINE PACKAGE

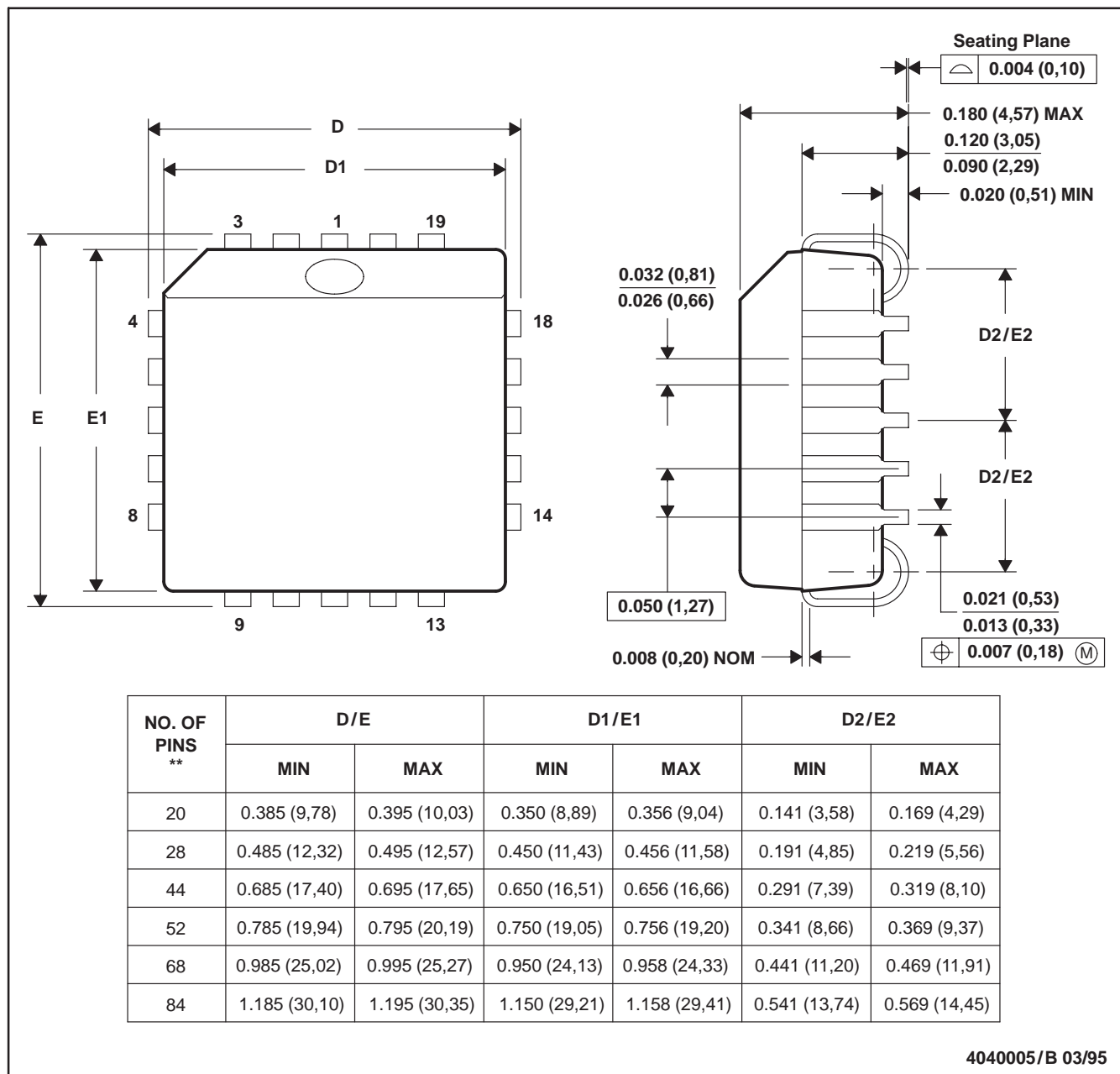


- NOTES:
- A. All linear dimensions are in millimeters. Dimensioning and tolerancing per ASME Y14.5M-1994.
  - B. This drawing is subject to change without notice.
  -  The 28 pin end lead shoulder width is a vendor option, either half or full width.

FN (S-PQCC-J\*\*)

PLASTIC J-LEADED CHIP CARRIER

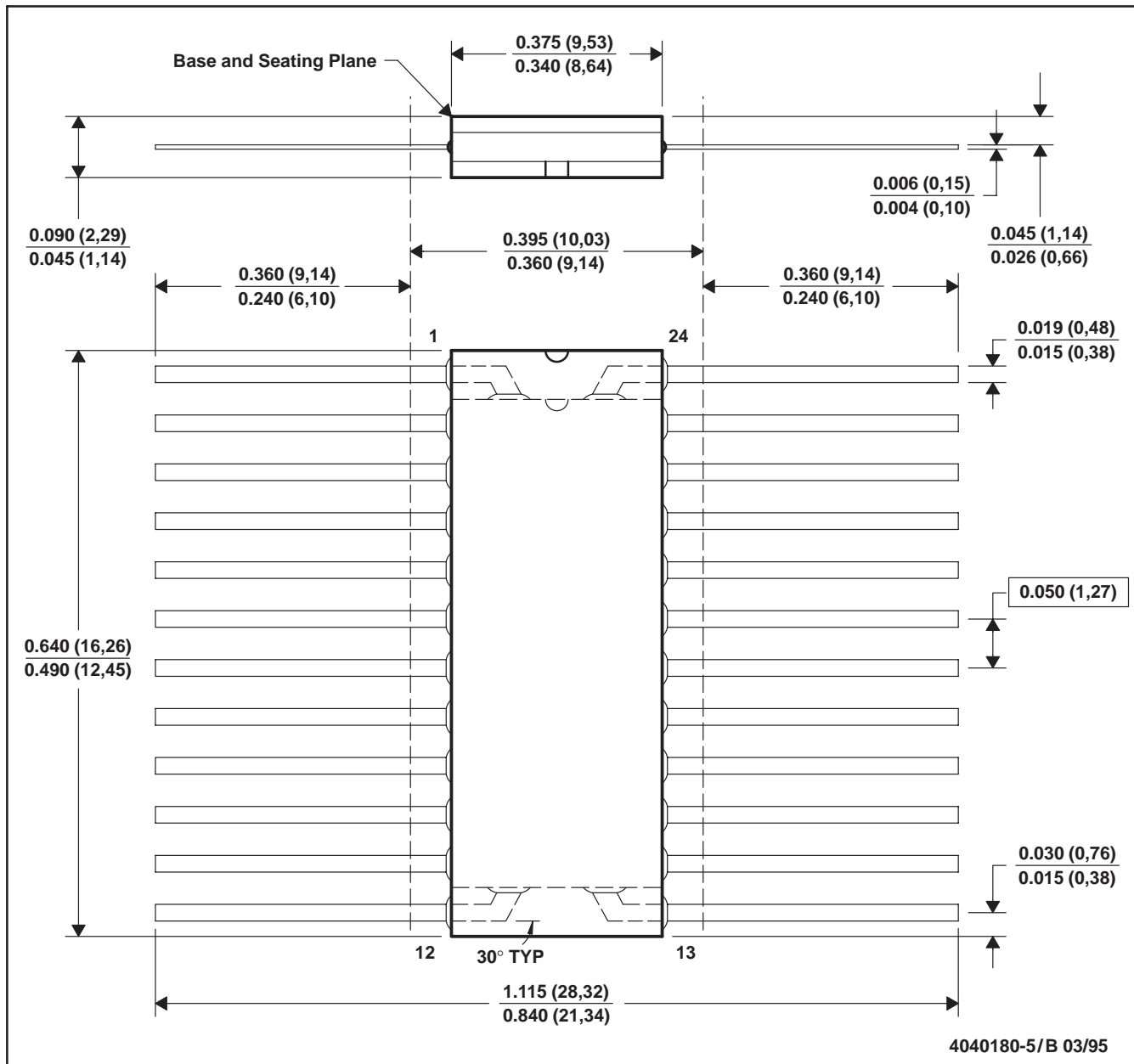
20 PIN SHOWN



- NOTES: A. All linear dimensions are in inches (millimeters).  
 B. This drawing is subject to change without notice.  
 C. Falls within JEDEC MS-018

W (R-GDFP-F24)

CERAMIC DUAL FLATPACK

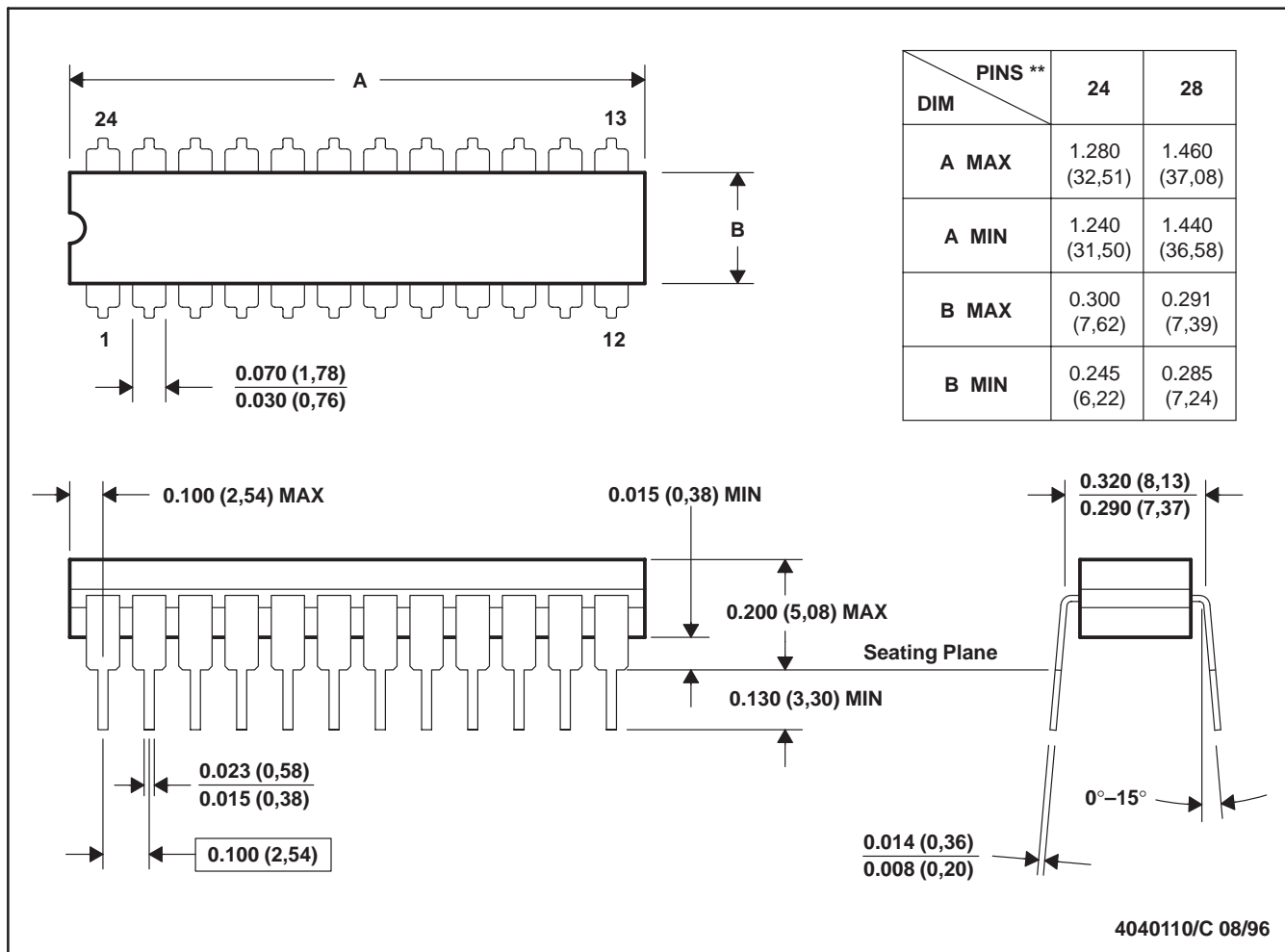


- NOTES:
- A. All linear dimensions are in inches (millimeters).
  - B. This drawing is subject to change without notice.
  - C. This package can be hermetically sealed with a ceramic lid using glass frit.
  - D. Falls within MIL-STD-1835 GDFP2-F24 and JEDEC MO-070AD
  - E. Index point is provided on cap for terminal identification only.

JT (R-GDIP-T\*\*)

CERAMIC DUAL-IN-LINE

24 LEADS SHOWN



4040110/C 08/96

- NOTES: A. All linear dimensions are in inches (millimeters).  
 B. This drawing is subject to change without notice.  
 C. This package can be hermetically sealed with a ceramic lid using glass frit.  
 D. Index point is provided on cap for terminal identification.  
 E. Falls within MIL STD 1835 GDIP3-T24, GDIP4-T28, and JEDEC MO-058 AA, MO-058 AB

## IMPORTANT NOTICE

Texas Instruments Incorporated and its subsidiaries (TI) reserve the right to make corrections, modifications, enhancements, improvements, and other changes to its products and services at any time and to discontinue any product or service without notice. Customers should obtain the latest relevant information before placing orders and should verify that such information is current and complete. All products are sold subject to TI's terms and conditions of sale supplied at the time of order acknowledgment.

TI warrants performance of its hardware products to the specifications applicable at the time of sale in accordance with TI's standard warranty. Testing and other quality control techniques are used to the extent TI deems necessary to support this warranty. Except where mandated by government requirements, testing of all parameters of each product is not necessarily performed.

TI assumes no liability for applications assistance or customer product design. Customers are responsible for their products and applications using TI components. To minimize the risks associated with customer products and applications, customers should provide adequate design and operating safeguards.

TI does not warrant or represent that any license, either express or implied, is granted under any TI patent right, copyright, mask work right, or other TI intellectual property right relating to any combination, machine, or process in which TI products or services are used. Information published by TI regarding third-party products or services does not constitute a license from TI to use such products or services or a warranty or endorsement thereof. Use of such information may require a license from a third party under the patents or other intellectual property of the third party, or a license from TI under the patents or other intellectual property of TI.

Reproduction of TI information in TI data books or data sheets is permissible only if reproduction is without alteration and is accompanied by all associated warranties, conditions, limitations, and notices. Reproduction of this information with alteration is an unfair and deceptive business practice. TI is not responsible or liable for such altered documentation. Information of third parties may be subject to additional restrictions.

Resale of TI products or services with statements different from or beyond the parameters stated by TI for that product or service voids all express and any implied warranties for the associated TI product or service and is an unfair and deceptive business practice. TI is not responsible or liable for any such statements.

TI products are not authorized for use in safety-critical applications (such as life support) where a failure of the TI product would reasonably be expected to cause severe personal injury or death, unless officers of the parties have executed an agreement specifically governing such use. Buyers represent that they have all necessary expertise in the safety and regulatory ramifications of their applications, and acknowledge and agree that they are solely responsible for all legal, regulatory and safety-related requirements concerning their products and any use of TI products in such safety-critical applications, notwithstanding any applications-related information or support that may be provided by TI. Further, Buyers must fully indemnify TI and its representatives against any damages arising out of the use of TI products in such safety-critical applications.

TI products are neither designed nor intended for use in military/aerospace applications or environments unless the TI products are specifically designated by TI as military-grade or "enhanced plastic." Only products designated by TI as military-grade meet military specifications. Buyers acknowledge and agree that any such use of TI products which TI has not designated as military-grade is solely at the Buyer's risk, and that they are solely responsible for compliance with all legal and regulatory requirements in connection with such use.

TI products are neither designed nor intended for use in automotive applications or environments unless the specific TI products are designated by TI as compliant with ISO/TS 16949 requirements. Buyers acknowledge and agree that, if they use any non-designated products in automotive applications, TI will not be responsible for any failure to meet such requirements.

Following are URLs where you can obtain information on other Texas Instruments products and application solutions:

### Products

Amplifiers	<a href="http://amplifier.ti.com">amplifier.ti.com</a>
Data Converters	<a href="http://dataconverter.ti.com">dataconverter.ti.com</a>
DLP® Products	<a href="http://www.dlp.com">www.dlp.com</a>
DSP	<a href="http://dsp.ti.com">dsp.ti.com</a>
Clocks and Timers	<a href="http://www.ti.com/clocks">www.ti.com/clocks</a>
Interface	<a href="http://interface.ti.com">interface.ti.com</a>
Logic	<a href="http://logic.ti.com">logic.ti.com</a>
Power Mgmt	<a href="http://power.ti.com">power.ti.com</a>
Microcontrollers	<a href="http://microcontroller.ti.com">microcontroller.ti.com</a>
RFID	<a href="http://www.ti-rfid.com">www.ti-rfid.com</a>
RF/IF and ZigBee® Solutions	<a href="http://www.ti.com/lprf">www.ti.com/lprf</a>

### Applications

Audio	<a href="http://www.ti.com/audio">www.ti.com/audio</a>
Automotive	<a href="http://www.ti.com/automotive">www.ti.com/automotive</a>
Broadband	<a href="http://www.ti.com/broadband">www.ti.com/broadband</a>
Digital Control	<a href="http://www.ti.com/digitalcontrol">www.ti.com/digitalcontrol</a>
Medical	<a href="http://www.ti.com/medical">www.ti.com/medical</a>
Military	<a href="http://www.ti.com/military">www.ti.com/military</a>
Optical Networking	<a href="http://www.ti.com/opticalnetwork">www.ti.com/opticalnetwork</a>
Security	<a href="http://www.ti.com/security">www.ti.com/security</a>
Telephony	<a href="http://www.ti.com/telephony">www.ti.com/telephony</a>
Video & Imaging	<a href="http://www.ti.com/video">www.ti.com/video</a>
Wireless	<a href="http://www.ti.com/wireless">www.ti.com/wireless</a>

Mailing Address: Texas Instruments, Post Office Box 655303, Dallas, Texas 75265  
Copyright © 2009, Texas Instruments Incorporated

## Looking for pricing, stock, or lifecycle information?

Click below to explore more details on WIN SOURCE:

- ⊖ [View TIBPAL20R8-7CFN on WIN SOURCE](#)
- ⊖ [Texas Instruments](#) Information

## Optimize Your Supply Chain with WIN SOURCE Solutions

- ✓ Global Sourcing Solution
- ✓ Obsolete Management
- ✓ Cost Control Management
- ✓ Shortage Management
- ✓ Alternative Solution
- ✓ Excess Inventory Management