



**THE DATASHEET OF
NB3H5150-01MNTXG**



2.5 V / 3.3 V Low Noise Multi-Rate Clock Generator

NB3H5150-01

MARKING DIAGRAM*

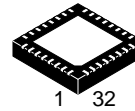

QFN32
 MN SUFFIX
 CASE 485CE

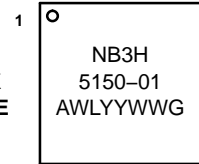

Description

The NB3H5150-01 is a high performance Multi-Rate Clock generator which simultaneously synthesizes up to four different frequencies from a single PLL using a 25 MHz input reference. The reference frequency can be provided by a crystal, LVCMOS/LVTTL, LVPECL, HCSL or LVDS differential signals. The REFMODE pin will select the reference source.

Three output banks (CLK1A/CLK1B to CLK3A/CLK3B) produce user selectable frequencies of: 33.33 MHz, 50 MHz, 100 MHz, 125 MHz, or 156.25 MHz and have ultra-low noise/jitter performance of less than 0.3 ps.

The fourth output bank (CLK4A/CLK4B) can produce the following integer and FRAC-N frequencies in pin-strap mode: 25 MHz, 33.33 MHz, 66.66 MHz, 100 MHz, 125 MHz, 133.33 MHz, 156.25 MHz or 161.1328 MHz.

Each output block can create two single-ended in-phase LVCMOS outputs or one differential pair of LVPECL outputs.

Each of the four output blocks is independently powered by a separate VDDO, 2.5 V/3.3 V for LVPECL, 1.8 V/2.5 V/3.3 V for LVCMOS.

The serial (I²C and SMBUS) interface can be used to load register files into the NB3H5150-01 to program a variety of functions including the frequencies and output levels of each output which can be individually enabled and disabled.

Features

- Flexible Input Reference – 25 MHz Crystal, Oscillator, Single-Ended or Differential Clock
- Four Independent User-Programmable Clock Frequencies from 25 MHz to 250 MHz
- Independently Configurable Outputs:
 - Up to Eight LVCMOS Single Ended outputs or,
 - Up to Four Differential LVPECL Outputs or any combination of LVCMOS and LVPECL
- Flexible Input/Core and Output Power Supply Combinations:
 - VDD (Core) = 3.3 V ±5% or 2.5 V ±5%
 - VDDO_n (Outputs) = 3.3 V ±5% or 2.5 V ±5% or 1.8 V ±5% (LVCMOS Only)
- Independent Power Supply for each Output Bank
- 300 ps max Output Rise and Fall Times, LVPECL
- 1000 ps max Output Rise and Fall Times, LVCMOS
- 300 fs maximum RMS Phase Jitter Interger-N (CLK1:4) 156.25 MHz
- 1 ps maximum RMS Phase Jitter FRAC-N (CLK4) 161.1328 MHz
- I²C / SMBus Compatible Interface
- -40°C to +85°C Ambient Operating Temperature
- Zero ppm Multiplication Error
- Fractional Divide Ratios for Implementing Arbitrary FEC/Inverse-FEC Ratios
- For Additional Pin-strap Frequency and Output Type Combinations, Contact **onsemi** Sales Office
- 32-Pin QFN, 5 mm x 5 mm
- This is a Pb-Free Device

Applications

- Telecom
- Networking
- Ethernet
- SONET

- A = Assembly Location
- WL = Wafer Lot
- YY = Year
- WW = Work Week
- G = Pb-Free Package

*For additional marking information, refer to Application Note AND8002/D.

ORDERING INFORMATION

See detailed ordering and shipping information on page 18 of this data sheet.

NB3H5150-01

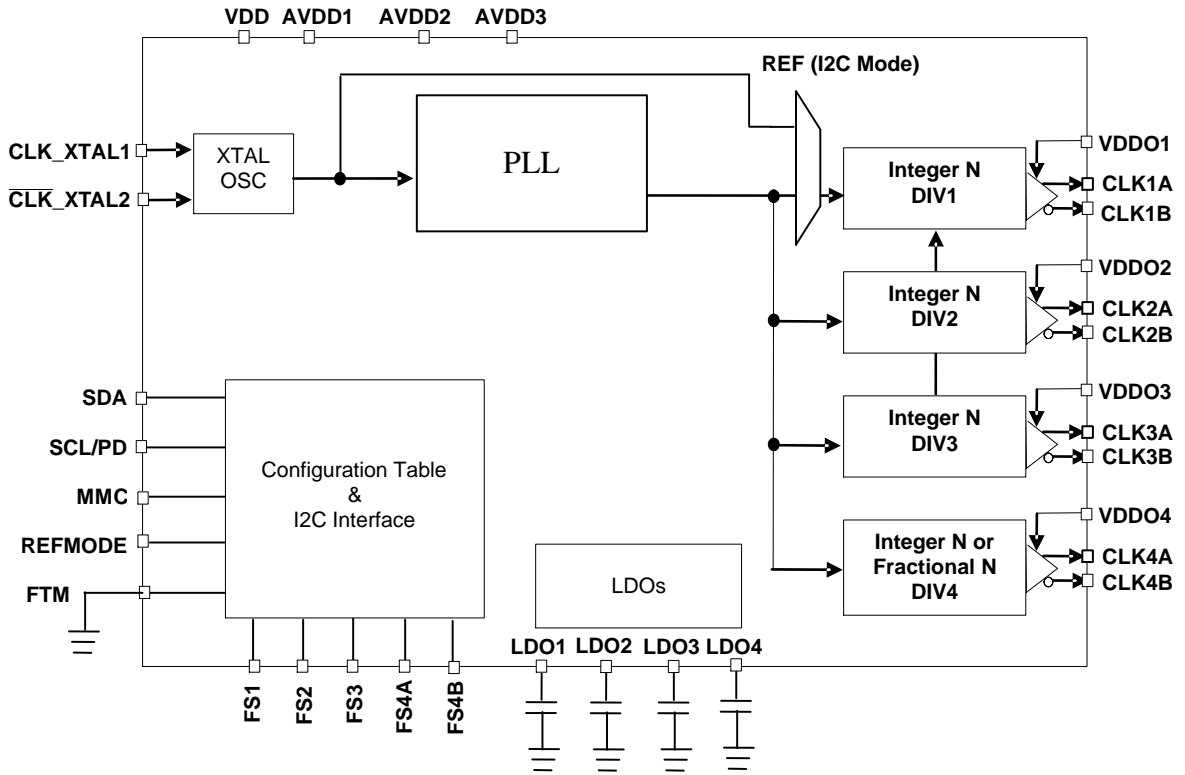

Figure 1. Simplified Block Diagram of NB3H5150-01

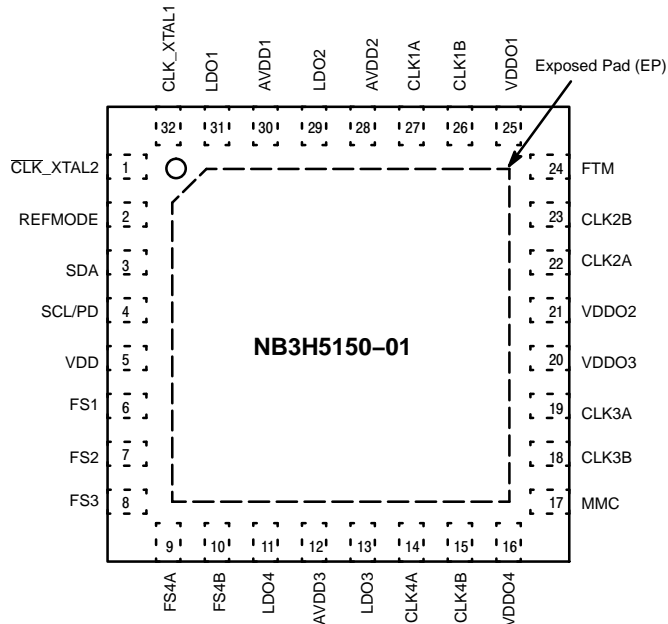

Figure 2. 32-Lead QFN Pinout (Top View)

NB3H5150-01

Table 1. PIN DESCRIPTION

Pin	Name	I/O	Description
1	CLK_XTAL2	Crystal or LVPECL/LVDS Input	Crystal Output or Differential Clock Input (complementary); If CLK_XTAL1 is used as single-ended input, CLK_XTAL2 must be connected to ground. See Table 2.
2	REFMODE	LVTTL/LVCMOS Input	Reference Input Select to either use a crystal, or overdrive with a single-ended or differential input; see Table 2. Internal pull-down.
3	SDA	LVTTL/LVCMOS Input	Serial Data Input for I2C/SMBus compatible; Defaults High when left open; internal pull-up. 5V tolerant.
4	SCL/PD	LVTTL/LVCMOS Input	Serial Clock Input for I2C/SMBus compatible; Defaults High when left open; internal pull-up. SCL/PD is also a device power-down pin (when High) in pin-strap mode only. 5V tolerant.
5	VDD	Power	3.3 V / 2.5 V Positive Supply Voltage for the Inputs and Core
6	FS1	LVTTL/LVCMOS Input	Frequency Select 1 for DIV1, CLK1A & CLK1B; Three-level input buffer; Default is mid-logic level; internal RPull-up and RPull-down. See Table 3.
7	FS2	LVTTL/LVCMOS Input	Frequency Select 2 for DIV2, CLK2A & CLK2B; Three-level input buffer; Default is mid-logic level; internal RPull-up and RPull-down. See Table 3.
8	FS3	LVTTL/LVCMOS Input	Frequency Select 3 for DIV3, CLK3A, & CLK3B; Three-level input buffer; Default is mid-logic level; internal RPull-up and RPull-down. See Table 3.
9	FS4A	LVTTL/LVCMOS Input	Frequency Select 4A for DIV4, CLK4A & CLK4B; Three-level input buffer; Default is mid-logic level; internal RPull-up and RPull-down. See Table 4.
10	FS4B	LVTTL/LVCMOS Input	Frequency Select 4B for DIV4, CLK4A & CLK4B; Three-level input buffer; Default is mid-logic level; internal RPull-up and RPull-down. See Table 4.
11	LDO4	Power	1.8 V LDO – Install Power Conditioning Bypass Capacitor to Ground
12	AVDD3	Power	3.3 V / 2.5 V Positive Supply Voltage for Analog circuits. AVDD3 = VDD.
13	LDO3	Power	1.8V LDO – Install Power Conditioning Bypass Capacitor to Ground
14	CLK4A	Output	LVCMOS (single-ended) or Non- Inverted Differential LVPECL Clock A for Channel 4 Output
15	CLK4B	Output	LVCMOS (single-ended) or Inverted Differential LVPECL Clock B for Channel 4 Output
16	VDDO4	Power	3.3 V / 2.5 V / 1.8 V Positive Supply Voltage for the CLK4A/4B Outputs
17	MMC	LVTTL/LVCMOS Input	Mix Mode Control Pin for use as a combination of FS _n settings and I2C setting for the CLK(n) outputs in the I2C mode; see Table 5. No logic level default; use a RPull-up resistor for High or a RPull-down resistor for Low.
18	CLK3B	Output	LVCMOS (single-ended) or Inverted Differential LVPECL Clock B for Channel 3 Output
19	CLK3A	Output	LVCMOS (single-ended) or Non-Inverted Differential LVPECL Clock A for Channel 3 Output
20	VDDO3	Power	3.3 V / 2.5 V / 1.8 V Positive Supply Voltage for the CLK3A/3B Outputs
21	VDDO2	Power	3.3 V / 2.5 V / 1.8 V Positive Supply Voltage for the CLK2A/2B Outputs
22	CLK2A	Output	LVCMOS (single-ended) or Non- Inverted Differential LVPECL Clock A for Channel 2 Output
23	CLK2B	Output	LVCMOS (single-ended) or Inverted Differential LVPECL Clock B for Channel 2 Output
24	FTM		Factory Test Mode. Must connect this pin to Ground.
25	VDDO1	Power	3.3 V / 2.5 V / 1.8 V Positive Supply Voltage for the CLK1A/1B Outputs
26	CLK1B	Output	LVCMOS (single-ended) or Inverted Differential LVPECL Clock B for Channel 1 Output
27	CLK1A	Output	LVCMOS (single-ended) or Non-Inverted Differential LVPECL Clock A for Channel 1 Output
28	AVDD2	Power	3.3 V / 2.5 V Positive Supply Voltage for Analog circuits. AVDD2 = VDD.
29	LDO2	Power	1.8 V LDO – Install Power Conditioning Bypass Capacitor to Ground
30	AVDD1	Power	3.3 V / 2.5 V Positive Supply Voltage for Analog circuits. AVDD1 = VDD.
31	LDO1	Power	1.8 V LDO – Install Power Conditioning Bypass Capacitor to Ground

Table 1. PIN DESCRIPTION

Pin	Name	I/O	Description
32	CLK_XTAL1	Crystal or LVTTTL/LVCMOS or LVPECL/LVDS Input	Crystal Input or Single-Ended or Differential Clock Input; If CLK_XTAL1 is used as single-ended input, CLK_XTAL2 must be connected to ground. See Table 2.
EP	Exposed Pad	Ground	Ground – Negative Power Supply is connected via the Exposed Pad . The Exposed Pad (EP) on the QFN-32 package bottom is thermally connected to the die for improved heat transfer out of package. The exposed pad must be attached to a heat sinking conduit. The pad is electrically connected to the die, carries all power supply return currents and must be electrically connected to GND.

1. All VDD, AVDDn, VDDOn, EP (GND) pins must be externally connected to a power supply for proper operation. VDD and AVDDn must all be at the same voltage.

NB3H5150-01 BASIC OPERATION

Introduction

The NB3H5150-01 is a Multi-Rate Clock Generator. The clock reference for the PLL can be either a 25 MHz crystal, single-ended LVCMOS or LVTTTL signal or a differential LVPECL, LVDS or HCSL signal.

There are two modes of operation for the NB3H5150-01, Pin-Strap and I²C.

In the **Pin-Strap Mode**, the user can select any of the defined output frequencies for each of the four output banks as specified in Tables 3 and 4 via the three-level Frequency Select pins: FS1, FS2, FS3, FS4A and FS4B.

In the **I²C mode**, the user can select one of the approved register files. Each register file is an expanded selection of output frequencies and level combinations, output enable/disable and bypass mode functions.

CLKnA & CLKnB – Output Frequency and Output Level Selection

There are four output banks: CLK1A&B, CLK2A&B and CLK3A&B are integer only divider outputs, whereas CLK4A&B can be set or programmed as an integer or fractional divider.

The output levels for each output bank can be LVPECL (differential) or LVCMOS (two single-ended). Output Enable / Disable functions are available in I²C only.

CLK1, 2, 3 and 4 outputs are not phase-aligned, in PLL or PLL bypass modes.

Power-On Output Default

Upon power-up, all four outputs will be forced to and held at static LVPECL levels (CLKnA = Low, CLKnB = High) until the PLL is stable. The PLL will be stable before any of the output Clocks, CLKnx, are enabled.

SDA & SCL/PD – Serial Data Interface – I2C

The NB3H5150-01 incorporates a two-wire Serial Data Interface to expand the flexibility and function of the NB3H5150-01 clock generator.

The I²C interface pins, SCL and SDA, are used to load register files into the NB3H5150-01.

These register files will configure the internal registers to achieve an expanded selection of output frequencies and levels combinations for each of the four output blocks.

Subsequent changes in the registers can then be performed with another register file to modify any of the output frequencies or output modes.

OE, Output Enable

An OE, Output Enable/Disable function is available only in the I²C mode by loading a register file, such that any individual output bank can be enabled or disabled. In LVCMOS modes outputs will disable LOW for CLKnA and CLKnB, while the LVPECL mode outputs will disable CLKnA = Low and CLKnB = High.

Mixed Mode Control (MMC)

In the I²C mode, the Mixed Mode Control (MMC) pin is used for a combination of FS_n settings and I²C settings to control the CLK(n) outputs' function as defined in Table 5.

REFMODE – Select a Crystal or External Clock Input Interface (See Table 2)

The REFMODE pin will select the reference input for the CLK_XTAL1 and CLK_XTAL2 pins to use either a crystal, an overdriven single-ended or differential input.

When using a crystal, set the REFMODE pin to a LOW. The CLK_XTAL1 and CLK_XTAL2 input pins will accept a 25 MHz crystal.

When using a direct-coupled differential input, set the REFMODE pin to a HIGH.

When REFMODE is HIGH, the CLK_XTAL1 and CLK_XTAL2 differential input pins have internal AC coupling capacitors selected with self-bias circuitry for the differential input buffer. This differential buffer will directly accept any differential signal including LVPECL, LVDS, HCSL or CML. Drive the CLK_XTAL1 pin with the true

signal and the CLK_XTAL2 pin with the complementary signal.

When overdriving the CLK_XTAL1 input pin with a single-ended signal set REFMODE to a HIGH, and connect CLK_XTAL2 to Ground. The input has internal AC coupling capacitor with self-bias circuitry.

Table 2. CRYSTAL INPUT INTERFACE AND REFMODE TRUTH TABLE

Input Mode Crystal/External Clock	REFMODE	CLK_XTAL1	CLKb_XTAL2
Crystal	LOW	Use a Crystal	Use a Crystal
Any Differential Input	HIGH	Overdrive with True Input	Overdrive with Complementary Input
Single-Ended Input	HIGH	Overdrive	Connect to Ground

LVC MOS Outputs

LVC MOS outputs are powered with VDDOn = 3.3 V, 2.5 V or 1.8 V

A 33 Ω series terminating resistor may be used on each clock output if the metal trace is longer than one inch.

Any unused LVC MOS output can be left floating, but there should be no metal trace attached to the package pin.

LVPECL Differential Outputs

The differential LVPECL outputs are powered with VDDO = 3.3 V or 2.5 V and must be properly loaded. See Figure 10.

Any unused differential output pair should either be left floating or terminated.

REF Out

In the PLL bypass mode available via I²C, the input reference frequency can be routed to CLK1A and CLK1B as phase aligned LVC MOS or differential LVPECL outputs with the same frequency. The output frequency and duty cycle equals the input frequency and duty cycle.

Power Supplies

The NB3H5150-01 has several power supply pins:

- VDD is the supply voltage for the input and digital core circuitry.
- AVDD1, AVDD2 and AVDD3 powers the core analog circuits. VDD = AVDD1 = AVDD2 = AVDD3.
- VDDO1, VDDO2, VDDO3 and VDDO4 are individual power supplies for each of the four CLKnA/B output banks.

Upon power-up, all four VDDOn pins must be connected to a power supply, even if only one output is being used.

Any combination of VDD and VDDOn power supply voltages is allowed.

A power supply filtering scheme in Figure 8 is recommended for best device performance.

When all VDD, AVDDn and VDDOn pins reach their minimum voltage per Table 8, the NB3H5150-01 will operate at the proper output frequencies.

EP Exposed Pad

The exposed pad on the bottom side of the package must be connected to Ground.

LDO Pins

The NB3H5150-01 has integrated low noise 1.8 V Low-Drop-Out (LDO) voltage regulators which provide power internal to the NB3H5150-01.

The LDOs require decoupling capacitors in the range of 1 μF to 10 μF for compensation and high frequency PSR.

When powered-down, the device turns off the LDOs and enters a low power shutdown mode consuming less than 1 mA.

FTM

This is a Factory Test Mode pin and must be connected to the Ground of the application for proper operation.

PIN-STRAP / FS_n Frequency Select MODE: (see Tables 3 and 4)

The NB3H5150-01 can be configured to operate in pin-strap mode where the control pins FS_nA/B can be set to generate the necessary clock outputs of the device.

Prerequisites:

- ♦ SDA and SCL/PD must be Low at all times while in pin-strap mode to enable FS control. If SDA ever goes High, pin-strap is exited and the only way to go back is to power cycle the device.
- ♦ Mixed Mode Control pin (MMC) level will be IGNORED.

Sequencing:

1. Upon device power-up (assuming SCL is LOW)
 - A All four CLK(n) frequency and output type selections will be pre-loaded according to the FS pin settings, but all four outputs will be held at static LVPECL levels (CLKnA = Low, CLKnB = High) until the PLL has become stable.
 - B After the PLL is stable, all CLK(n) output type selections (i.e. LVPECL or LVC MOS) will

NB3H5150-01

become effective and will begin to output the selected frequencies.

2. Subsequent changes to any FS pin(s) will cause the associated CLK(n) output(s) to momentarily go to static levels, and then to resume at the new frequency; CLK(n) will follow the FS(n) pin programmable Tables 3 and 4 for output frequencies and interface levels.

Note that in changing from LVPECL to LVCMOS (or vice-versa), output logic levels cannot be guaranteed. This is because the receiver inputs are not likely to change in a given application, and the LVPECL output loading in the application will also not change. It is logical to presume that the output type will be predetermined and fixed.

Therefore, in a system/application, the user should

be aware that subsequent change to the FS pin should only change frequency, and not output type.

3. Power off/on cycle will repeat the entire sequence
4. **Power Down**

To initiate the Power-Down mode, the SDA pin must be LOW and remain LOW. If the SCL/PD pin is taken HIGH at any time, the device enters a complete power-down mode with a current consumption of less than 1 mA for the entire device. When SCL/PD is subsequently taken LOW, the device will function as though power were removed and re-applied. That is, sequencing will begin at #1.

Power-down is also available via I²C with a register file.

FS(n) Pin Programmable Selection of Output Frequencies and Levels

Table 3. NB3H5150-01MNTXG – CLK1A:3A & CLK1B:3B OUTPUT FREQUENCY SELECT TABLE WITH 25 MHz CRYSTAL

Logic Level	FS1 (CLK1) (MHz)	FS2 (CLK2) (MHz)	FS3 (CLK3) (MHz)
Low	156.25 (LVPECL)	156.25 (LVPECL)	156.25 (LVPECL)
Mid / Float*	25.00 (LVPECL)	100.00 (LVPECL)	125.00 (LVPECL)
High	50.00 (LVPECL)	125.00 (LVPECL)	50.00 (LVPECL)

*(Default)

Table 4. NB3H5150-01MNTXG – CLK4A & CLK4B OUTPUT FREQUENCY SELECT TRUTH TABLE (MHz) WITH 25 MHz CRYSTAL*

FS4A	FS4B	CLK4 (MHz)	Divider Type
Low	Low	33.33 (LVCMOS)	Integer
Low	Mid / Float	66.66 (LVCMOS)	Fractional
Low	High	133.33 (LVCMOS)	Fractional
Mid / Float	Low	133.33 (LVPECL)	Fractional
Mid / Float*	Mid / Float*	156.25 (LVPECL)	Integer
Mid / Float	High	125.00 (LVPECL)	Integer
High	Low	25.00 (LVPECL)	Integer
High	Mid / Float	100.00 (LVPECL)	Integer
High	High	161.1328 (LVPECL)	Fractional

*(Default)

NB3H5150-01

I²C MODE: (see Table 5)

Some features that are not available in pin-strap mode can be obtained in I²C mode, such as Output Enable/Disable, By-Pass mode and Power-Down. In addition, output frequency and output levels can also be I²C controlled.

The NB3H5150-01 I²C Programming Guide can be found on the NB3H5150-01 web site. This application note provides details on configuring the NB3H5150-01 by writing to registers in the NB3H5150-01 with approved register files through the I²C/SMBus interface.

<http://www.onsemi.com/pub/Collateral/NB3H5150-01%20I2C%20PROGRAMMING%20GUIDE%20%20..PDF>

Register Files can be generated by the factory upon request.

Prerequisites:

- SDA and SCL must be connected to I²C SMBus
- SDA must be logic High.
 1. Upon device power-up.
 - A All four frequencies and output type selections will be preloaded according to the FS_n pin settings, but all four outputs will be held at static LVPECL levels until the PLL has become stable.

NOTE: After power up, changes to FS pins will be blocked from controlling device operation.
 - B Once the PLL is stable, the Mixed Mode Control pin (MMC) is checked:
 - i. If MMC is LOW, all CLK(n) outputs will remain at static LVPECL levels.
 - ii. If MMC is HIGH and FS4A is LOW, CLK1, CLK2, and CLK3 outputs will remain at static LVPECL levels. CLK4A/4B output frequency and output levels will become active after PLL stabilization time according to FS4A and FS4B pin selection in Table 4.

After power up, changes to all pins will be ignored.
 - iii. If MMC is HIGH and FS4A MID or HIGH, CLK1, CLK2, and CLK3 output frequency and type will become active after PLL stabilization time according to their respective FS1, FS2 and FS3 pin selection in Table 3.

CLK4A/4B outputs remain at Static LVPECL Levels.

After power up, changes to all pins will be ignored except the SDA and SCL inputs.

iv. The FS4A and FS4B pins set the bus address when MMC pin is LOW (see Table 5, I²C Device Address Table).

C The I²C interface can now be used to load register files into the NB3H5150-01. In I²C Mode, configuration of Output Enables, output frequency, output levels of each output, specific block power-down control, bypass mode, etc. are all possible.

D Any outputs which were held in static level mode (described above) will be released for operation.

CLK(n) outputs will be active at the programmed frequencies and levels.

CLK(n) outputs will react to any subsequent changes to the I²C bus.

If any output channel is not programmed, then output is loaded from FS_n pins.

A Power Cycle will clear all previous register information and I²C mode will repeat to number 1 in the power up sequence.

To simplify device configuration, **onsemi** provides desktop software, that can be downloaded from http://www.onsemi.com/pub/Collateral/NB3H5150-01_G UI.ZIP which will operate in conjunction with the NB3H5150-01 evaluation board (EVB). The NB3H5150-01 GUI manual can also be found on the web site.

When the software is connected to an NB3H5150-01 EVB, it can control the selection of numerous clock output frequencies for each of the four CLK outputs and the output type as well as Output Enable/Disable.

I²C Programmable Selection of Output Frequency and Level

Each register file can be loaded from GUI into the demo board, or loaded into the I²C port of the device.

Table 5. SDA, SCL AND MMC CONTROL PINS FOR OUTPUT FUNCTION

Mode	SDA	SCL/PD	MMC	Comments	Outputs (Note 2)	
					CLK1, CLK2, CLK3	CLK4
Pin-Strap FS Mode	L	L	X	Normal Operation	Toggle per Table 3	Toggle per Table 4
Power-Down	L	H	X		Off	Off
I ² C (Note 3)	Dynamic	Dynamic	X	I ² C Mode Is Active After Mixed Mode Power-Up Sequence	Active Per I ² C Map	Active Per I ² C Map

2. All outputs are static until after the PLL is stable.
 3. Any changes to the device configuration after power-up are made by reading and writing to registers through the I²C interface.
 4. Don't care state unless device address is matched by controller address.
- X = don't care

Table 5. SDA, SCL AND MMC CONTROL PINS FOR OUTPUT FUNCTION

Mode	SDA	SCL/PD	MMC	Comments	Outputs (Note 2)	
					CLK1, CLK2, CLK3	CLK4
Mixed Mode	H Note 4	H Note 4	L		Static LVPECL Logic Levels	Static LVPECL Logic Levels
	H Note 4	H Note 4	H FS4A = L		Static LVPECL Logic Levels	Active per Table 4
	H Note 4	H Note 4	H FS4A = M or H		Active per Table 3	Static LVPECL Logic Levels

2. All outputs are static until after the PLL is stable.
 3. Any changes to the device configuration after power-up are made by reading and writing to registers through the I2C interface.
 4. Don't care state unless device address is matched by controller address.
- X = don't care

Table 6. ATTRIBUTES

Characteristics		Value
ESD Protection	Human Body Model Machine Model Charge Device Model	> 2 kV > 150 V > 500 V
Moisture Sensitivity (Note 5)	32-QFN	Level 1
Flammability Rating	Oxygen Index: 28 to 34	UL 94 V-0 @ 0.125 in
Transistor Count		245, 894
Meets or exceeds JEDEC Spec EIA/JESD78 IC Latchup Test		

5. For additional information, see Application Note AND8003/D.

Table 7. MAXIMUM RATINGS

Symbol	Parameter	Condition	Rating	Unit	
V _{DD}	Positive Power Supply – Core	GND = 0 V	3.63	V	
AV _{DDn}	Positive Power Supply – Analog	GND = 0 V	3.63	V	
V _{DDOn}	Positive Power Supply – Outputs	GND = 0 V	3.63	V	
V _{IO}	Positive Input/Output Voltage	GND = 0 V	-0.5 to V _{DD} +0.5	V	
V _I	Positive Input Voltage SDA and SCL	GND = 0 V	5.5	V	
T _A	Operating Temperature Range	QFN-32	-40 to +85	°C	
T _{stg}	Storage Temperature Range		-65 to +150	°C	
θ _J	Maximum Junction Temperature		125	°C	
θ _{JA}	Thermal Resistance (Junction-to-Ambient) (Note 6)	QFN-32 QFN-32	0 lfpm 500 lfpm	31 27	°C/W °C/W
θ _{JC}	Thermal Resistance (Junction-to-Case) (Note 6)	QFN-32		12	°C/W
T _J	Maximum Junction Temperature			125	°C
T _{sol}	Wave Solder Pb-Free, 10 sec			265	°C

Stresses exceeding those listed in the Maximum Ratings table may damage the device. If any of these limits are exceeded, device functionality should not be assumed, damage may occur and reliability may be affected.

6. JEDEC standard multilayer board – 2S2P (2 signal, 2 power).

Table 8. DC CHARACTERISTICS

V_{DD} = AV_{DDn} = 3.3 V ±5% or 2.5 V ±5%; V_{DDOn} = 3.3 V ±5% or 2.5 V ±5% or 1.8 V ±5%; GND = 0 V; T_A = -40°C to 85°C

Symbol	Characteristic	Min	Typ	Max	Unit	
POWER SUPPLY / CURRENT (Note 12)						
V _{DD} /AV _{DDn}	Core Power Supply	V _{DD} = AV _{DDn} = 3.3 V	3.135	3.3	3.465	V
		V _{DD} = AV _{DDn} = 2.5 V	2.375	2.5	2.625	
V _{DDOn}	Output Power Supply	V _{DDOn} = 3.3 V	3.135	3.3	3.465	
		V _{DDOn} = 2.5 V	2.375	2.5	2.625	
		V _{DDOn} = 1.8 V (LVCMOS only)	1.71	1.8	1.89	
I _{DD} /I _{ADDn}	Core and Input Power Supply Current for V _{DD} and AV _{DDn}					mA
	V _{DD} = 3.3 V		60	75		
		CLK4 Integer		75	90	
		CLK4 Frac-N		55	70	
	V _{DD} = 2.5 V		70	85		
		CLK4 Integer				
		CLK4 Frac-N				
I _{DDOn}	Output Buffer Power Supply Current for V _{DDOn}					mA
	Incremental I _{DDO} Current by One Output Bank and Output Type					
	LVPECL – One differential LVPECL output pair (CLKnA & CLKnB)					
	Frequency Independent					
		V _{DDO} = 3.3 V		40	50	
		V _{DDO} = 2.5 V		40	50	
	LVCMOS – Two LVCMOS outputs (CLKnA & CLKnB)					
		V _{DDO} = 3.3 V		20	25	
		V _{DDO} = 2.5 V		17	23	
		V _{DDO} = 1.8 V		15	21	
I _{DDPWRDN}	Power Down Current SCL/PD = High		100			µA

LVPECL OUTPUTS (Note 7 and 8) V_{DDOn} = 3.3 V ±5% or 2.5 V ±5%; See Figure 10

V _{OH}	Output HIGH Voltage	V _{DDO} – 1.200		V _{DDO} – 0.895	V
V _{OL}	Output LOW Voltage	V _{DDO} – 2.000		V _{DDO} – 1.600	V
V _{SWING}	V _{OUT PK-PK} Voltage Swing	550	720	900	mV

NB3H5150-01

Table 8. DC CHARACTERISTICS

$V_{DD} = AV_{DDn} = 3.3\text{ V} \pm 5\%$ or $2.5\text{ V} \pm 5\%$; $V_{DDOn} = 3.3\text{ V} \pm 5\%$ or $2.5\text{ V} \pm 5\%$ or $1.8\text{ V} \pm 5\%$; $GND = 0\text{ V}$; $T_A = -40^\circ\text{C}$ to 85°C

Symbol	Characteristic	Min	Typ	Max	Unit
--------	----------------	-----	-----	-----	------

LVC MOS OUTPUT; See Figure 12

V_{OH}	Output HIGH Voltage $I_{OH} = 12\text{ mA}$	$V_{DDO} - 0.5$		V_{DDO}	V
V_{OL}	Output LOW Voltage $I_{OL} = 12\text{ mA}$	GND		0.5	V
R_{OUT}	Output Impedance		15		Ω

CRYSTAL INPUT DRIVEN SINGLE-ENDED (REFMODE = 1) (see Figure 3 and 5) (Note 9)

V_{IHSE}	CLK_XTAL1 Single-Ended Input HIGH Voltage	200		$V_{DD} + 300$	mV
V_{ILSE}	CLK_XTAL1 Single-Ended Input LOW Voltage	GND - 300		$V_{IHSE} - 200$	mV
V_{th}	Input Threshold Reference Voltage Range	100		$V_{DD} - 100$	mV
V_{ISE}	Single-Ended Input Voltage ($V_{IH} - V_{IL}$)	200		$V_{DD} + 600$	mV

CRYSTAL INPUTS DRIVEN DIFFERENTIALLY (REFMODE = 1) (see Figure 4 and 6) (Note 11)

V_{IHD}	Differential Input HIGH Voltage	100		V_{DD}	mV
V_{ILD}	Differential Input LOW Voltage	GND		$V_{IHD} - 100$	mV
V_{ID}	Differential Input Voltage ($V_{IHD} - V_{ILD}$)	100		V_{DD}	mV
V_{CMR}	Input Common Mode Range (Differential Configuration) (Note 10) (Figure 8)	50		$V_{DD} - 50$	mV
I_{IH}	Input HIGH Current CLK_XTAL1 and CLKb_XTAL2	-10		10	μA
I_{IL}	Input LOW Current CLK_XTAL1 & CLKb_XTAL2	-10		10	μA

LVC MOS - CONTROL AND SDA & SCL/PD INPUTS

V_{IH}	Input HIGH Voltage for MMC & REFMODE Pins	$V_{DD} = 3.3\text{ V}$ $V_{DD} = 2.5\text{ V}$	2.1 1.75		$V_{DD} + 0.3$	V
V_{IH}	Input HIGH Voltage for SDA & SCL/PD Pins	$V_{DD} = 3.3\text{ V}$ $V_{DD} = 2.5\text{ V}$	2.1 1.75		5.5	V
V_{IL}	Input LOW Voltage for Control Pins and SDA & SCL/PD	$V_{DD} = 3.3\text{ V}$ $V_{DD} = 2.5\text{ V}$	GND - 0.3		0.7 0.7	V
I_{IH}	Input HIGH Current		-150		150	μA
I_{IL}	Input LOW Current		-150		150	μA
V_{IHtri}	Tri-Level Input High Voltage (FSn pins)		$V_{DD} \times 75\%$		V_{DD}	V
		$V_{DD} = 3.3\text{ V}$	2.48		V_{DD}	
		$V_{DD} = 2.5\text{ V}$	1.88		V_{DD}	
V_{IMtri}	Tri-Level Input Med Voltage (FSn pins)		$V_{DD} \times 40\%$		$V_{DD} \times 60\%$	V
		$V_{DD} = 3.3\text{ V}$	1.32		1.98	
		$V_{DD} = 2.5\text{ V}$	1.00		1.67	
V_{ILtri}	Tri-Level Input Low Voltage (FSn pins)		GND		$V_{DD} \times 25\%$	V
		$V_{DD} = 3.3\text{ V}$	0.00		0.83	
		$V_{DD} = 2.5\text{ V}$	0.00		0.63	
RIN	Input Impedance			10		k Ω
CIN	Input Capacitance - Crystal pins; REFMODE = H			2		pF

Product parametric performance is indicated in the Electrical Characteristics for the listed test conditions, unless otherwise noted. Product performance may not be indicated by the Electrical Characteristics if operated under different conditions.

NOTE: Device will meet the specifications after thermal equilibrium has been established when mounted in a test socket or printed circuit board with maintained transverse airflow greater than 500 lfm.

7. LVPECL Outputs loaded with $50\ \Omega$ to $V_{DDO} - 2\text{ V}$ for proper operation.
8. LVPECL Output parameters vary 1:1 with V_{DDO} .
9. V_{IH} , V_{IL} , V_{th} , and V_{ISE} parameters must be complied with simultaneously.
10. V_{CMR} min varies 1:1 with GND, V_{CMR} max varies 1:1 with V_{DD} .
11. V_{IHD} , V_{ILD} , V_{ID} and V_{CMR} parameters must be complied with simultaneously.
12. I_{DD} / V_{DD} is independent of I_{DDOn} / V_{DDOn}

NB3H5150-01

Table 9. AC CHARACTERISTICS

$V_{DD} = AV_{DDn} = 3.3\text{ V} \pm 5\%$ or $2.5\text{ V} \pm 5\%$; $V_{DDO} = 3.3\text{ V} \pm 5\%$ or $2.5\text{ V} \pm 5\%$ or $1.8\text{ V} \pm 5\%$; $GND = 0\text{ V}$; $T_A = -40^\circ\text{C}$ to 85°C (Note 13)

Symbol	Characteristic	Min	Typ	Max	Unit
f_{CLKIN}	External Clock / Crystal Input Frequency – PLL Mode	-1000 ppm	25	+1000 ppm	MHz
f_{INBP}	External Clock Input Frequency – PLL Bypass Mode I ² C Mode; $f_{in} = f_{out}$	1		50	MHz
$f_{CLK1,2,3}$	CLK1, CLK2, CLK3 Typical Output Clock Frequencies; $f_{in} = 25\text{ MHz}$		25 50 100 125 156.25		MHz
f_{CLK4}	CLK4 Outputs Typical Output Clock Frequencies; $f_{in} = 25\text{ MHz}$ Resolution of 1 Hz Integer Frac-N		25 33.33 100 125 156.25 66.66 133.33 161.1328		MHz
$f_{SDA/SCL}$	Serial Data and Clock Rates		100k		bps
t_{PWsCL}	Serial Clock Pulse Width	1			μs
t_{Wt}	Time SCL/PD Pin must be Held Low to “Wake-up” the Device	100			ns
t_{DC}	Output Clock Duty Cycle (Crystal or Reference Duty Cycle = 50%) PLL Mode; $<1\text{ ns } t_f / t_r$ LVPECL $f_{out} = 156.25\text{ MHz}$ LVCMOS $f_{out} = 33.33\text{ MHz}$ PLL Bypass Mode; Input Duty Cycle = 50%, $V_{INPP} \geq 1.2\text{ V}$	47.5 47.5 45	50 50	52.5 52.5 55	%
Φ_N	Phase Noise (Integer-N) $f_{out} = 156.25\text{ MHz}$, $f_{in} = 25\text{ MHz}$ Crystal, LVPECL		1 kHz 10 kHz 100 kHz 1 MHz 10 MHz 20 MHz	-115 -130 -140 -145 -153 -153	dBc
Φ_N	Phase Noise (Integer-N) $f_{out} = 100\text{ MHz}$, $f_{in} = 25\text{ MHz}$ Crystal, LVCMOS		1 kHz 10 kHz 100 kHz 1 MHz 10 MHz 20 MHz	-120 -136 -142 -145 -156 -156	dBc
Φ_N	Phase Noise (Frac-N) $f_{out} = 161.1328\text{ MHz}$, $f_{in} = 25\text{ MHz}$ Crystal, LVPECL		1 kHz 10 kHz 100 kHz 1 MHz 10 MHz 20 MHz	-118 -128 -130 -132 -153 -153	dBc
Φ_N	Phase Noise (Frac-N) $f_{out} = 133.33\text{ MHz}$, $f_{in} = 25\text{ MHz}$ Crystal, LVCMOS		1 kHz 10 kHz 100 kHz 1 MHz 10 MHz 20 MHz	-117 -126 -126 -131 -153 -153	dBc
$t_{jit}(\Phi)$	RMS Phase Jitter – 25 MHz Crystal (Note 15) Integration Range: 12 kHz – 20 MHz $f_{out} = 156.25\text{ MHz}$, Integer CLK _n $f_{out} = 161.1328\text{ MHz}$; Frac-N CLK4			300 1000	fs

Table 9. AC CHARACTERISTICS

$V_{DD} = AV_{DDn} = 3.3\text{ V} \pm 5\%$ or $2.5\text{ V} \pm 5\%$; $V_{DDO} = 3.3\text{V} \pm 5\%$ or $2.5\text{ V} \pm 5\%$ or $1.8\text{ V} \pm 5\%$; $GND = 0\text{ V}$; $T_A = -40^\circ\text{C}$ to 85°C (Note 13)

Symbol	Characteristic	Min	Typ	Max	Unit
tjit(Φ)	Additive RMS Phase Jitter (PLL Bypass in I ² C Mode) Integration Range:12 kHz – 5 MHz f _{out} = 25 MHz, CLK1 LVCMOS		50		fs
tpd	Input to Output Propagation Delay (PLL Bypass in I ² C Mode) 25 MHz		5		ns
PSRR	Ripple Induced Phase Spur Level 100 kHz & 1 MHz, 100 mVpp, Ripple Injected on V _{DD} /AV _{DDn} ≤ 100 MHz		-60		dBc
t _r /t _f	Output Rise/Fall Times (CLKnA/CLKnB), 20% – 80% of V _{DDO_n} f _{out} = 156.25 MHz LVPECL f _{out} = 33.33 MHz @ V _{DDO} = 3.3 V LVCMOS – 5 pF	120 500	200 800	300 1000	ps
V _{INPP}	Input Voltage Swing (Differential Configuration) (Note 14)	100		1200	mV
Stabilization Time	Stabilization Time From Power-up V _{DD} = 3.3 V to First Edge Out Upon Reprogram – (Pin-Strap mode), Change of Configuration Power-up to Static Output Levels – (Pin-Strap mode) Power-up to I ² C Ready		5 3 1 5	6 3	ms
t _{PWRDWN}	Time to Power Down, SCL/PD Low-to-High	50	100	200	μs

Product parametric performance is indicated in the Electrical Characteristics for the listed test conditions, unless otherwise noted. Product performance may not be indicated by the Electrical Characteristics if operated under different conditions.

NOTE: Device will meet the specifications after thermal equilibrium has been established when mounted in a test socket or printed circuit board with maintained transverse airflow greater than 500 lfpm.

13. Measured by using a 25 MHz crystal as clock source. All LVPECL outputs are loaded with an external R_L = 50 Ω to V_{DDO} – 2 V (Figure 9); LVCMOS outputs loaded with R_S = 33 Ω, C_L = 5 pF, 5" 50 Ω trace, (Figure 11).

14. Input and output voltage swings are single-ended measurements operating in a differential mode.

15. V_{DD} = 3.3 V, V_{DDO} = 2.5 V (LVPECL) or 1.8 V (LVCMOS).

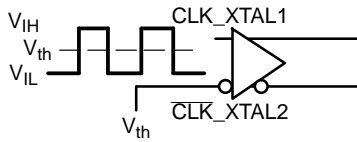

Figure 3. Differential Input Driven Single-Ended

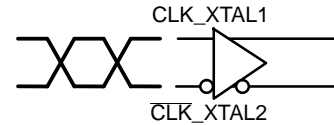

Figure 4. Differential Inputs Driven Differentially

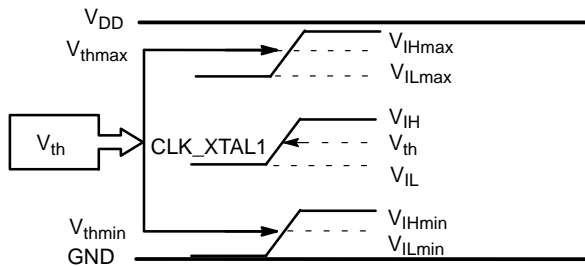

Figure 5. V_{th} Diagram

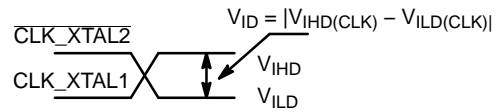

Figure 6. Differential Inputs Driven Differentially

NB3H5150-01

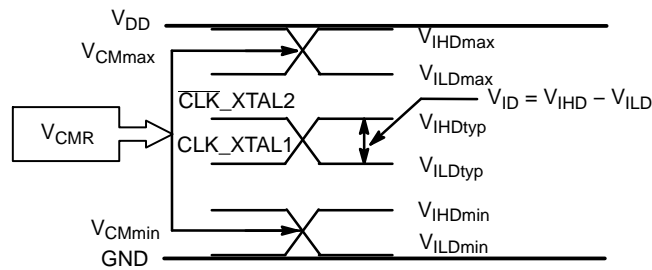

Figure 7. V_{CMR} Diagram

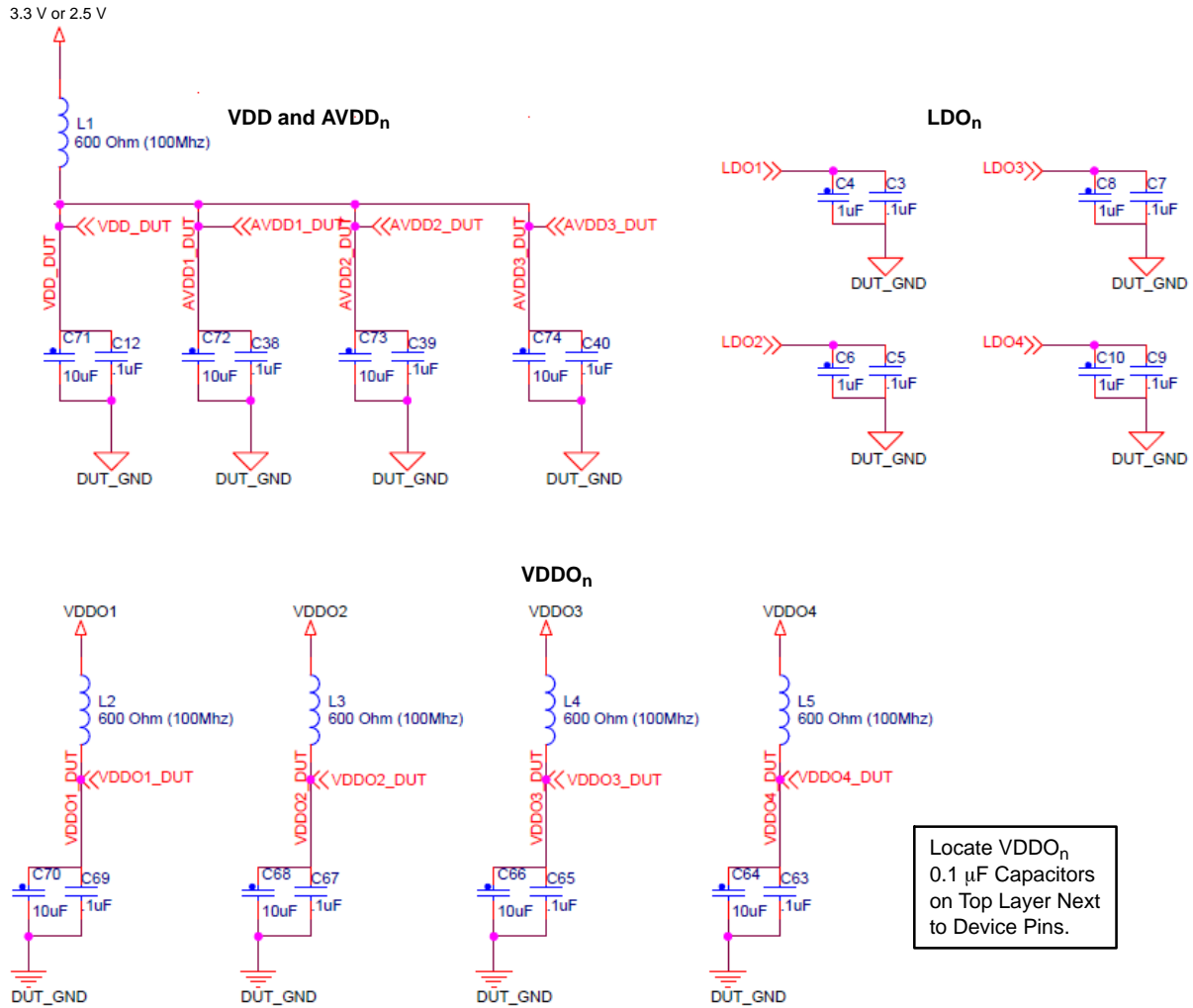

Figure 8. NB3H5150-01 Power Supply Filter Scheme

NB3H5150-01

Table 10. RECOMMENDED CRYSTAL SPECIFICATIONS

Crystal	Fundamental AT-Cut
Frequency	25 MHz
Load Capacitance	16 pF – 20 pF
Shunt Capacitance, C0	7 pF Max
Equivalent Series Resistance	50 Ω Max
Initial Accuracy at 25°C	\pm 20 ppm
Temperature Stability	\pm 30 ppm
Aging	\pm 20 ppm
C0/C1 Ratio	250 Max
Crystal max Drive Level	100 μ W

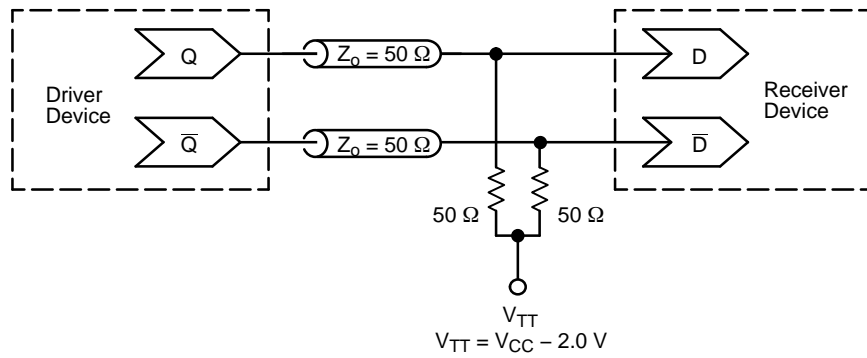

Figure 9. Typical Termination for LVPECL Output Driver and Device Evaluation (See Application Note AND8020/D – Termination of ECL Logic Devices.)

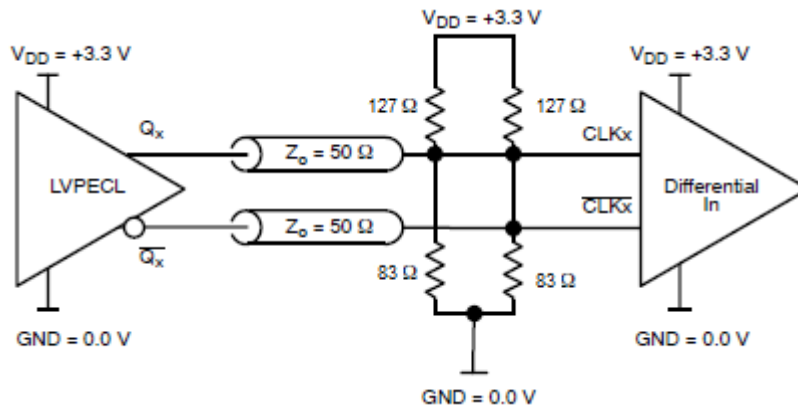

Figure 10. Optional LVPECL output Loading and Termination

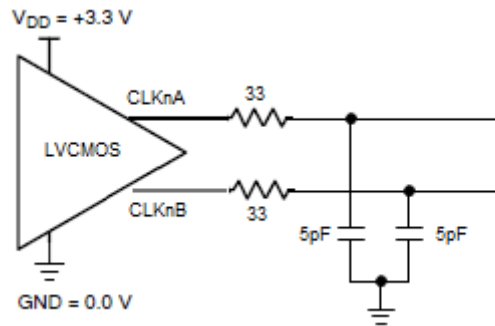

Figure 11. Typical LVC MOS Output Test Setup for Evaluation

Interfacing from 3.3 V LVPECL to LVDS

Since the output levels V_{OH} and V_{OL} of 3.3 V LVPECL are more positive than the input range of LVDS receiver, a special interface is required. (See Figures 12 and 13). Furthermore, the open emitter design of the ECL output structure needs proper termination, which can be implemented with a resistor divider network to generate proper LVDS DC levels (eq. 1).

$$R_{E1} + R_{E2} = R_E \quad (\text{eq. 1})$$

The resistor divider network will divide the output common mode voltage of LVPECL ($V_{CM(LVPECL)}$) to input common mode voltage of LVDS ($V_{CM(LVDS)}$).

$$\frac{R_{E2}}{R_{E1} + R_{E2}} = \frac{V_{CM(LVDS)}}{V_{CM(LVPECL)}} \quad (\text{eq. 2})$$

Where:

R_{E1} = partial emitter current bias resistor

R_{E2} = partial emitter current bias resistor

$R_E = R_{E1} + R_{E2}$, the total emitter current bias resistor (see AND8020)

$V_{CM(LVPECL)}$ = Common Mode Voltage

$V_{CM(LVDS)}$ = Common Mode Voltage

3.3 V LVPECL output will be able to drive an LVDS receiver with or without an internal 100 Ω termination resistor.

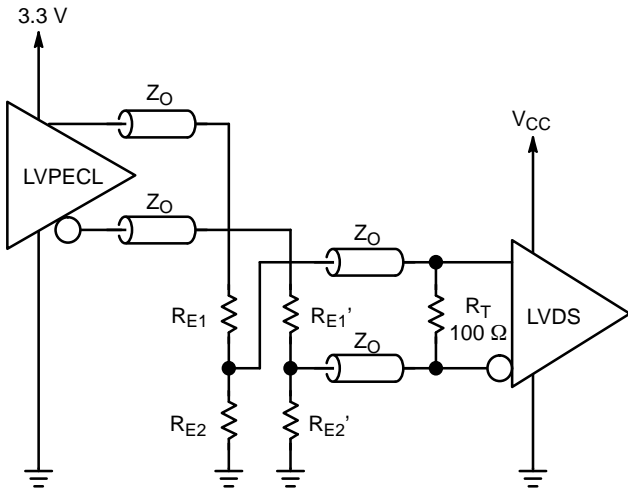

Figure 12. Interfacing 3.3 V LVPECL to LVDS

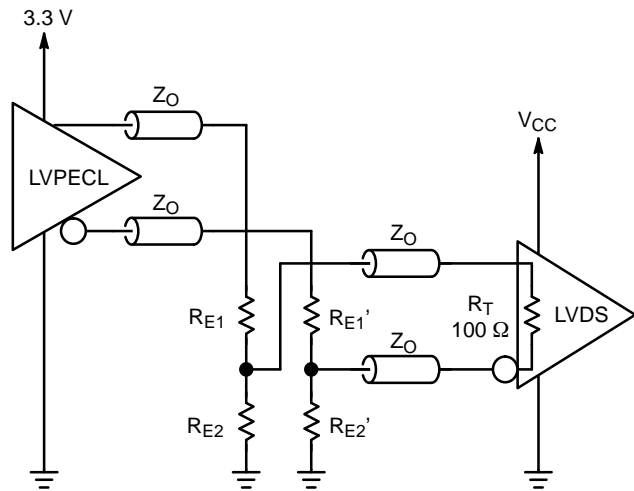

Figure 13. Interfacing LVPECL to LVDS with Internal 100 Ω Termination Resistor

Examples:

For 50 Ω controlled impedance, the resistor values for 3.3V LVPECL converted to LVDS voltage levels are as follows:

- $R_{E1} = 55 \Omega$
- $R_{E2} = 95 \Omega$
- $R_{E1} + R_{E2} = R_E = 150 \Omega$
- $R_T = 100 \Omega$
- $V_{CM(LVPECL)} = 1.9 \text{ V}$
- $V_{CM(LVDS)} = 1.2 \text{ V}$

Interfacing from 2.5 V LVPECL to LVDS

Provided that the LVDS receiver can tolerate large input voltage peak to peak amplitude, the 2.5 V LVPECL output can be directly interfaced to an LVDS receiver using proper ECL termination. The 2.5 V LVPECL output will be able to drive an LVDS receiver with or without internal 100 Ω termination resistor. (See Figures 14, 15 and 16).

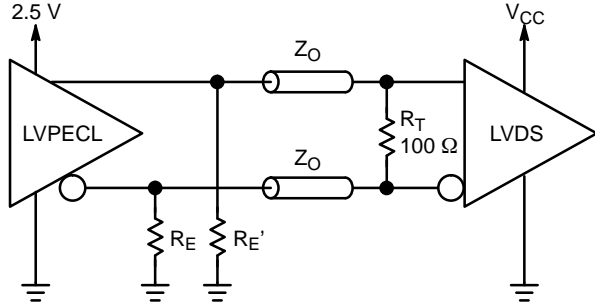

Figure 14. Interfacing 2.5 V LVPECL to LVDS with External 100 Ω Termination Resistor

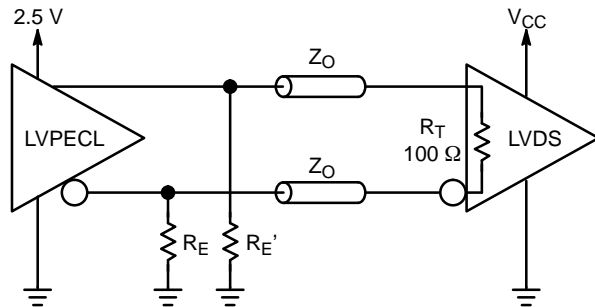

Figure 15. Interfacing 2.5 V LVPECL to LVDS with Internal 100 Ω Termination Resistor

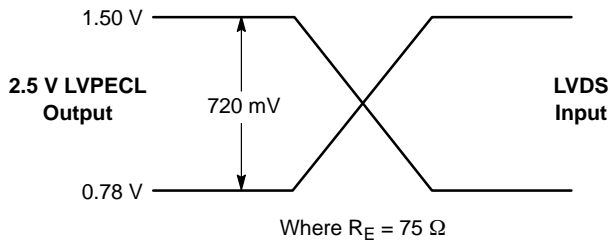

Figure 16. PSPICE Simulation Levels of 2.5V LVPECL to LVDS Interface with Example Resistor Values

Furthermore, a series termination can be used to reduce the amplitude of the signal as described in AND8020 application note, by placing R_S resistor between the driver and the transmission line. (See Figures 17, 18 and 19).

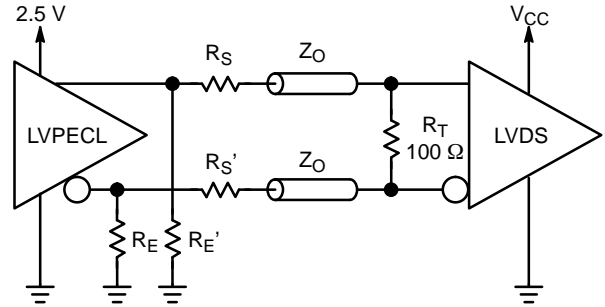

Figure 17. Interfacing 2.5 V LVPECL to LVDS with Series R_S and External 100 Ω Termination Resistor

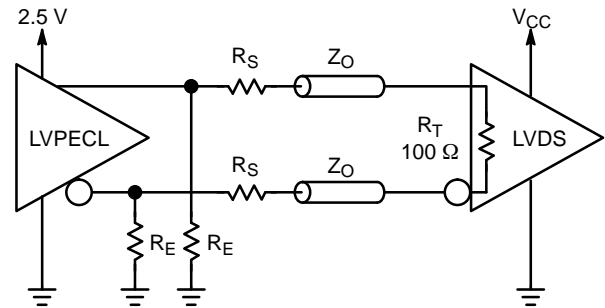

Figure 18. Interfacing 2.5 V LVPECL to LVDS with Series R_S and Internal 100 Ω Termination Resistor

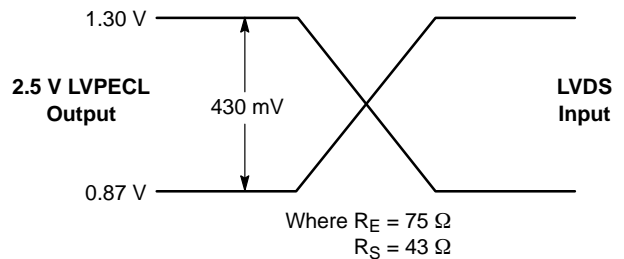

Figure 19. PSPICE Simulation Levels of 2.5V LVPECL to LVDS Interface with Series R_S Resistor

NB3H5150-01

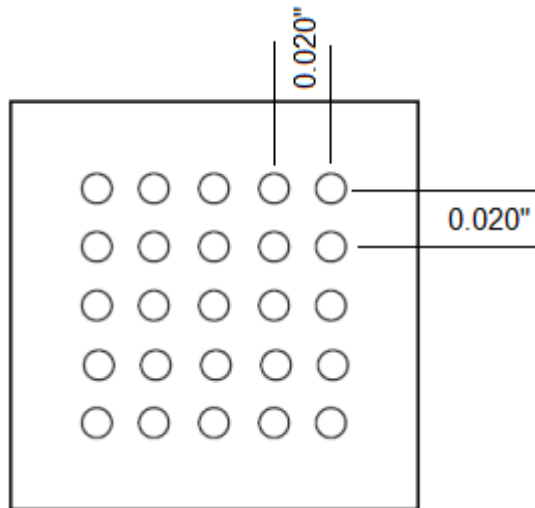

Figure 20. Via Layout Recommendation for Exposed Pad, QFN-32 Package

The exposed pad on the NB3H5150-01 QFN-32 package carries all of the power supply return currents. It is therefore important that the necessary current capability be satisfied, as well as the thermal transfer from the die to the PCB. Figure 20 shows a recommended via layout pattern for the exposed pad. Via spacing = 0.02", filled vias preferred.

ORDERING INFORMATION

Device	Marking	Tables	Package	Shipping [†]
NB3H5150-01MNTXG	NB3H 5150-01	3 & 4	QFN32 (Pb-Free)	1000 / Tape & Reel

[†]For information on tape and reel specifications, including part orientation and tape sizes, please refer to our Tape and Reel Packaging Specifications Brochure, BRD8011/D.

MECHANICAL CASE OUTLINE

PACKAGE DIMENSIONS

ON Semiconductor®

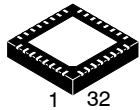

1 32
SCALE 2:1

QFN32 5x5, 0.5P
CASE 485CE
ISSUE O

DATE 07 FEB 2012

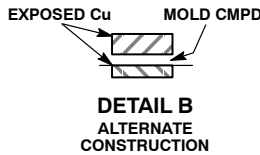
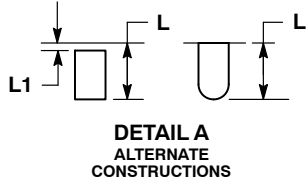
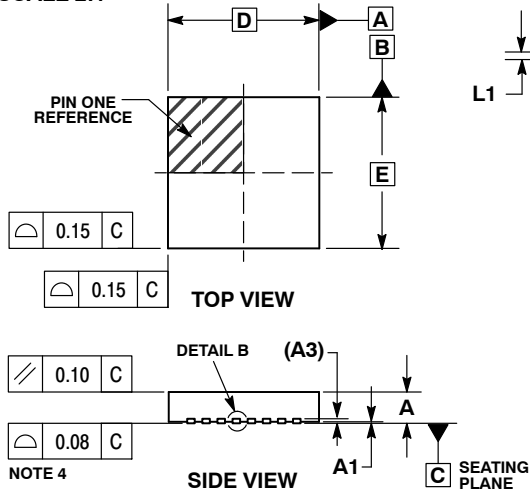

- NOTES:
- DIMENSIONING AND TOLERANCING PER ASME Y14.5M, 1994.
 - CONTROLLING DIMENSION: MILLIMETERS.
 - DIMENSION *b* APPLIES TO PLATED TERMINAL AND IS MEASURED BETWEEN 0.15 AND 0.30 MM FROM THE TERMINAL TIP.
 - COPLANARITY APPLIES TO THE EXPOSED PAD AS WELL AS THE TERMINALS.

MILLIMETERS		
DIM	MIN	MAX
A	0.80	1.00
A1	---	0.05
A3	0.20	REF
<i>b</i>	0.20	0.30
D	5.00	BSC
D2	3.40	3.60
E	5.00	BSC
E2	3.40	3.60
<i>e</i>	0.50	BSC
K	0.20	---
L	0.30	0.50
L1	---	0.15

GENERIC MARKING DIAGRAM*

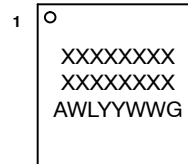

- XXXXX = Specific Device Code
 A = Assembly Location
 WL = Wafer Lot
 YY = Year
 WW = Work Week
 G = Pb-Free Package

*This information is generic. Please refer to device data sheet for actual part marking.
 Pb-Free indicator, "G" or microdot "•", may or may not be present.

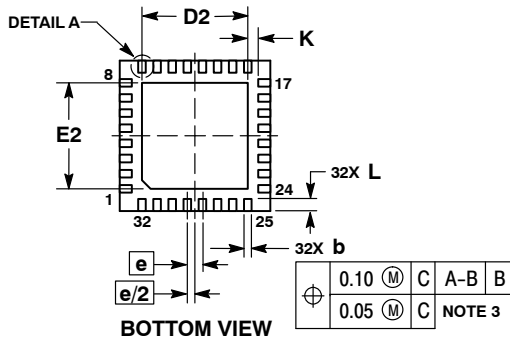

RECOMMENDED SOLDERING FOOTPRINT*

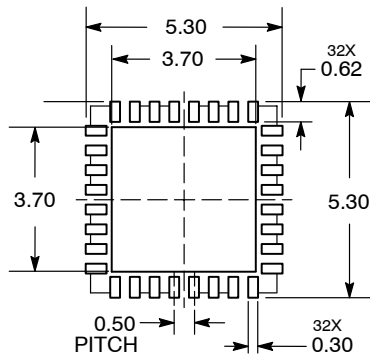

*For additional information on our Pb-Free strategy and soldering details, please download the ON Semiconductor Soldering and Mounting Techniques Reference Manual, SOLDERRM/D.

DOCUMENT NUMBER:	98AON34336E	Electronic versions are uncontrolled except when accessed directly from the Document Repository. Printed versions are uncontrolled except when stamped "CONTROLLED COPY" in red.
DESCRIPTION:	TDFN8, 2X3, 0.5P	PAGE 1 OF 1

ON Semiconductor and ON are trademarks of Semiconductor Components Industries, LLC dba ON Semiconductor or its subsidiaries in the United States and/or other countries. ON Semiconductor reserves the right to make changes without further notice to any products herein. ON Semiconductor makes no warranty, representation or guarantee regarding the suitability of its products for any particular purpose, nor does ON Semiconductor assume any liability arising out of the application or use of any product or circuit, and specifically disclaims any and all liability, including without limitation special, consequential or incidental damages. ON Semiconductor does not convey any license under its patent rights nor the rights of others.

onsemi, **Onsemi**, and other names, marks, and brands are registered and/or common law trademarks of Semiconductor Components Industries, LLC dba "**onsemi**" or its affiliates and/or subsidiaries in the United States and/or other countries. **onsemi** owns the rights to a number of patents, trademarks, copyrights, trade secrets, and other intellectual property. A listing of **onsemi**'s product/patent coverage may be accessed at www.onsemi.com/site/pdf/Patent-Marking.pdf. **onsemi** reserves the right to make changes at any time to any products or information herein, without notice. The information herein is provided "as-is" and **onsemi** makes no warranty, representation or guarantee regarding the accuracy of the information, product features, availability, functionality, or suitability of its products for any particular purpose, nor does **onsemi** assume any liability arising out of the application or use of any product or circuit, and specifically disclaims any and all liability, including without limitation special, consequential or incidental damages. Buyer is responsible for its products and applications using **onsemi** products, including compliance with all laws, regulations and safety requirements or standards, regardless of any support or applications information provided by **onsemi**. "Typical" parameters which may be provided in **onsemi** data sheets and/or specifications can and do vary in different applications and actual performance may vary over time. All operating parameters, including "Typicals" must be validated for each customer application by customer's technical experts. **onsemi** does not convey any license under any of its intellectual property rights nor the rights of others. **onsemi** products are not designed, intended, or authorized for use as a critical component in life support systems or any FDA Class 3 medical devices or medical devices with a same or similar classification in a foreign jurisdiction or any devices intended for implantation in the human body. Should Buyer purchase or use **onsemi** products for any such unintended or unauthorized application, Buyer shall indemnify and hold **onsemi** and its officers, employees, subsidiaries, affiliates, and distributors harmless against all claims, costs, damages, and expenses, and reasonable attorney fees arising out of, directly or indirectly, any claim of personal injury or death associated with such unintended or unauthorized use, even if such claim alleges that **onsemi** was negligent regarding the design or manufacture of the part. **onsemi** is an Equal Opportunity/Affirmative Action Employer. This literature is subject to all applicable copyright laws and is not for resale in any manner.

ADDITIONAL INFORMATION

TECHNICAL PUBLICATIONS:

Technical Library: www.onsemi.com/design/resources/technical-documentation
onsemi Website: www.onsemi.com

ONLINE SUPPORT: www.onsemi.com/support

For additional information, please contact your local Sales Representative at www.onsemi.com/support/sales

Looking for pricing, stock, or lifecycle information?

Click below to explore more details on WIN SOURCE:

- ⊖ [View NB3H5150-01MNTXG on WIN SOURCE](#)
- ⊖ [ON Semiconductor Information](#)

Optimize Your Supply Chain with WIN SOURCE Solutions

- ✓ Global Sourcing Solution
- ✓ Obsolete Management
- ✓ Cost Control Management
- ✓ Shortage Management
- ✓ Alternative Solution
- ✓ Excess Inventory Management