

104 dB, 24-Bit, 192 kHz Stereo Audio CODEC

D/A Features

- ◆ Multi-bit Delta Sigma Modulator
- ◆ 104 dB Dynamic Range
- ◆ -90 dB THD+N
- ◆ Up to 192 kHz Sampling Rates
- ◆ Single-Ended Analog Architecture
- ◆ Volume Control with Soft Ramp
 - 0.5 dB Step Size
 - Zero Crossing, Click-Free Transitions
- ◆ Popguard® Technology
 - Minimizes the Effects of Output Transients
- ◆ Filtered Line-Level Outputs
- ◆ Selectable Serial Audio Interface Formats
 - Left-Justified up to 24-bit
 - I²S up to 24-bit
 - Right-Justified 16-, 18-, 20-, and 24-bit
- ◆ Selectable 50/15 μs De-Emphasis
- ◆ Control Output for External Muting

A/D Features

- ◆ Multi-bit Delta Sigma Modulator
- ◆ 104 dB Dynamic Range
- ◆ -95 dB THD+N
- ◆ Stereo 6:1 Input Multiplexer
- ◆ Programmable Gain Amplifier (PGA)
 - ± 12 dB Gain, 0.5 dB Step Size
 - Zero Crossing, Click-Free Transitions
- ◆ Stereo Microphone Inputs
 - +32 dB Gain Stage
 - Low-Noise Bias Supply
- ◆ Up to 192 kHz Sampling Rates
- ◆ Selectable Serial Audio Interface Formats
 - Left-Justified up to 24-bit
 - I²S up to 24-bit
- ◆ High-Pass Filter or DC Offset Calibration

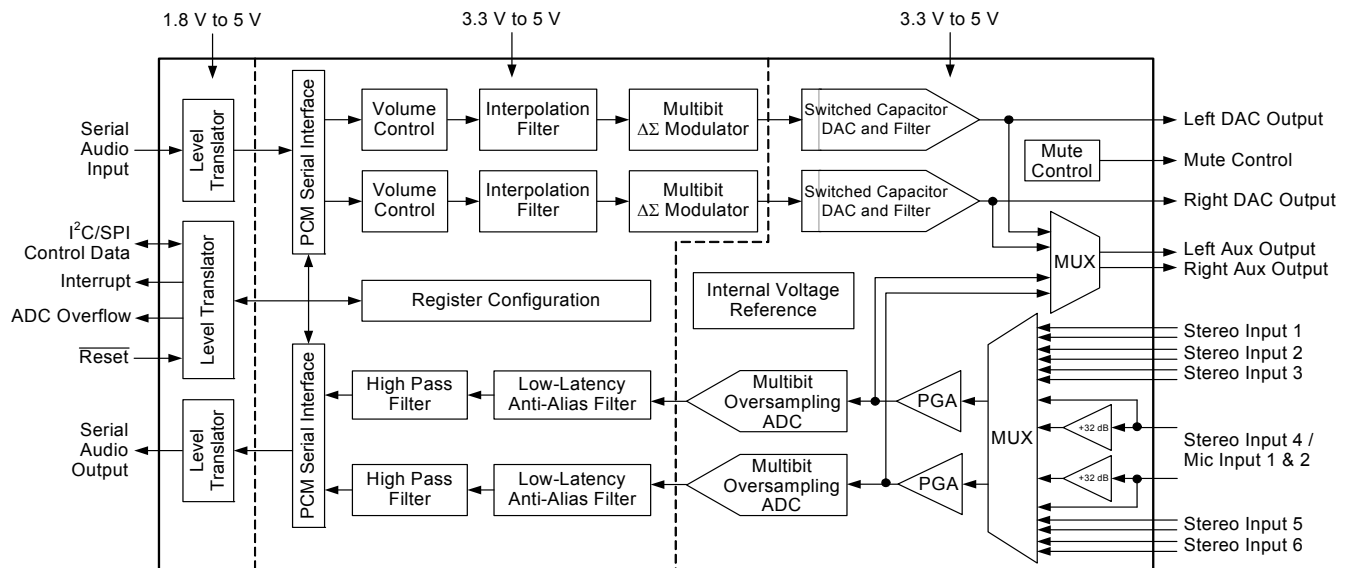

System Features

- ◆ Direct Interface with 1.8 V to 5 V Logic Levels
- ◆ Optional Asynchronous Serial Port Operation
 - Each Serial Port Supports Master or Slave Operation
- ◆ Selectable Auxiliary Analog Output
 - Allows Analog Monitoring of Either the ADC Input Signal after PGA or DAC Output Signal
- ◆ Internal Digital Loopback
- ◆ Power-Down Mode
 - Available for A/D, D/A, CODEC, Mic Preamplifier
- ◆ +3.3 V to +5 V Analog Power Supply
- ◆ +3.3 V to +5 V Digital Power Supply
- ◆ Supports I²C® and SPI™ Control Port Interfaces
- ◆ Pin-Compatible with CS5345

General Description

The CS4245 is a highly integrated stereo audio CODEC. The CS4245 performs stereo analog-to-digital (A/D) and digital-to-analog (D/A) conversion of up to 24-bit serial values at sample rates up to 192 kHz.

A 6:1 stereo input multiplexer is included for selecting between line-level or microphone-level inputs. The microphone input path includes a +32 dB gain stage and a low-noise bias voltage supply. The PGA is available for line or microphone inputs and provides gain/attenuation of ±12 dB in 0.5 dB steps.

The output of the PGA is followed by an advanced 5th-order, multi-bit delta sigma modulator and digital filtering/decimation. Sampled data is transmitted by the serial audio interface at rates from 4 kHz to 192 kHz in either Slave or Master Mode.

The D/A converter is based on a 4th-order multi-bit delta sigma modulator with an ultra-linear low-pass filter and offers a volume control that operates with a 0.5 dB step size. It incorporates selectable soft ramp and zero crossing transition functions to eliminate clicks and pops.

Standard 50/15 μs de-emphasis is available for a 44.1 kHz sample rate for compatibility with digital audio programs mastered using the 50/15 μs pre-emphasis technique.

Integrated level translators allow easy interfacing between the CS4245 and other devices operating over a wide range of logic levels.

The CS4245 is available in a 48-pin LQFP package in both Commercial (-10° to +70° C) and Automotive (-40° to +105° C) grade. The CDB4245 Customer Demonstration board is also available for device evaluation and implementation suggestions. Please see [“Ordering Information” on page 58](#) for complete details.

TABLE OF CONTENTS

1. PIN DESCRIPTIONS	7
2. CHARACTERISTICS AND SPECIFICATIONS	9
SPECIFIED OPERATING CONDITIONS	9
ABSOLUTE MAXIMUM RATINGS	9
DAC ANALOG CHARACTERISTICS	10
DAC COMBINED INTERPOLATION & ON-CHIP ANALOG FILTER RESPONSE	11
ADC ANALOG CHARACTERISTICS	13
ADC ANALOG CHARACTERISTICS	15
ADC DIGITAL FILTER CHARACTERISTICS	16
AUXILIARY OUTPUT ANALOG CHARACTERISTICS	17
AUXILIARY OUTPUT ANALOG CHARACTERISTICS	18
AUXILIARY OUTPUT ANALOG CHARACTERISTICS	19
DC ELECTRICAL CHARACTERISTICS	20
DIGITAL INTERFACE CHARACTERISTICS	21
SWITCHING CHARACTERISTICS - SERIAL AUDIO PORT 1	22
SWITCHING CHARACTERISTICS - SERIAL AUDIO PORT 2	24
SWITCHING CHARACTERISTICS - CONTROL PORT - I ² C FORMAT	27
SWITCHING CHARACTERISTICS - CONTROL PORT - SPI FORMAT	28
3. TYPICAL CONNECTION DIAGRAM	29
4. APPLICATIONS	30
4.1 Recommended Power-Up Sequence	30
4.2 System Clocking	30
4.2.1 Synchronous / Asynchronous Mode	30
4.2.2 Master Clock	30
4.2.3 Master Mode	32
4.2.4 Slave Mode	32
4.3 High-Pass Filter and DC Offset Calibration	32
4.4 Analog Input Multiplexer, PGA, and Mic Gain	34
4.5 Input Connections	34
4.6 Output Connections	34
4.7 Output Transient Control	35
4.7.1 Power-Up	35
4.7.2 Power-Down	35
4.7.3 Serial Interface Clock Changes	35
4.8 Auxiliary Analog Output	35
4.9 De-Emphasis Filter	35
4.10 Internal Digital Loopback	36
4.11 Mute Control	36
4.12 Control Port Description and Timing	37
4.12.1 SPI Mode	37
4.12.2 I ² C Mode	38
4.13 Interrupts and Overflow	39
4.14 Reset	40
4.15 Synchronization of Multiple Devices	40
4.16 Grounding and Power Supply Decoupling	40
5. REGISTER QUICK REFERENCE	41
6. REGISTER DESCRIPTION	42
6.1 Chip ID - Register 01h	42
6.2 Power Control - Address 02h	42
6.2.1 Freeze (Bit 7)	42
6.2.2 Power-Down MIC (Bit 3)	42
6.2.3 Power-Down ADC (Bit 2)	42

6.2.4 Power-Down DAC (Bit 1)	43
6.2.5 Power-Down Device (Bit 0)	43
6.3 DAC Control - Address 03h	43
6.3.1 DAC Functional Mode (Bits 7:6)	43
6.3.2 DAC Digital Interface Format (Bits 5:4)	43
6.3.3 Mute DAC (Bit 2)	43
6.3.4 De-Emphasis Control (Bit 1)	44
6.3.5 DAC Master / Slave Mode (Bit 0)	44
6.4 ADC Control - Address 04h	44
6.4.1 ADC Functional Mode (Bits 7:6)	44
6.4.2 ADC Digital Interface Format (Bit 4)	45
6.4.3 Mute ADC (Bit 2)	45
6.4.4 ADC High-Pass Filter Freeze (Bit 1)	45
6.4.5 ADC Master / Slave Mode (Bit 0)	45
6.5 MCLK Frequency - Address 05h	45
6.5.1 Master Clock 1 Frequency (Bits 6:4)	45
6.5.2 Master Clock 2 Frequency (Bits 2:0)	46
6.6 Signal Selection - Address 06h	46
6.6.1 Auxiliary Output Source Select (Bits 6:5)	46
6.6.2 Digital Loopback (Bit 1)	46
6.6.3 Asynchronous Mode (Bit 0)	46
6.7 Channel B PGA Control - Address 07h	47
6.7.1 Channel B PGA Gain (Bits 5:0)	47
6.8 Channel A PGA Control - Address 08h	47
6.8.1 Channel A PGA Gain (Bits 5:0)	47
6.9 ADC Input Control - Address 09h	47
6.9.1 PGA Soft Ramp or Zero Cross Enable (Bits 4:3)	47
6.9.2 Analog Input Selection (Bits 2:0)	48
6.10 DAC Channel A Volume Control - Address 0Ah	48
6.11 DAC Channel B Volume Control - Address 0Bh	48
6.11.1 Volume Control (Bits 7:0)	48
6.12 DAC Control 2 - Address 0Ch	49
6.12.1 DAC Soft Ramp or Zero Cross Enable (Bits 7:6)	49
6.12.2 Invert DAC Output (Bit 5)	49
6.12.3 Active High/Low (Bit 0)	50
6.13 Interrupt Status - Address 0Dh	50
6.13.1 ADC Clock Error (Bit 3)	50
6.13.2 DAC Clock Error (Bit 2)	50
6.13.3 ADC Overflow (Bit 1)	50
6.13.4 ADC Underflow (Bit 0)	50
6.14 Interrupt Mask - Address 0Eh	50
6.15 Interrupt Mode MSB - Address 0Fh	51
6.16 Interrupt Mode LSB - Address 10h	51
7. PARAMETER DEFINITIONS	52
8. DAC FILTER PLOTS	53
9. ADC FILTER PLOTS	55
10. PACKAGE DIMENSIONS	57
11. THERMAL CHARACTERISTICS AND SPECIFICATIONS	57
12. ORDERING INFORMATION	58
13. REVISION HISTORY	58

LIST OF FIGURES

Figure 1.DAC Output Test Load	12
Figure 2.Maximum DAC Loading	12
Figure 3.Master Mode Timing - Serial Audio Port 1	23
Figure 4.Slave Mode Timing - Serial Audio Port 1	23
Figure 5.Master Mode Timing - Serial Audio Port 2	25
Figure 6.Slave Mode Timing - Serial Audio Port 2	25
Figure 7.Format 0, Left-Justified up to 24-Bit Data	26
Figure 8.Format 1, I ² S up to 24-Bit Data	26
Figure 9.Format 2, Right-Justified 16-Bit Data. Format 3, Right-Justified 24-Bit Data.	26
Figure 10.Control Port Timing - I ² C Format	27
Figure 11.Control Port Timing - SPI Format	28
Figure 12.Typical Connection Diagram	29
Figure 13.Master Mode Clocking	32
Figure 14.Analog Input Architecture	34
Figure 15.De-Emphasis Curve	36
Figure 16.Suggested Active-Low Mute Circuit	37
Figure 17.Control Port Timing in SPI Mode	38
Figure 18.Control Port Timing, I ² C Write	38
Figure 19.Control Port Timing, I ² C Read	39
Figure 20.De-Emphasis Curve	44
Figure 21.DAC Single-Speed Stopband Rejection	53
Figure 22.DAC Single-Speed Transition Band	53
Figure 23.DAC Single-Speed Transition Band	53
Figure 24.DAC Single-Speed Passband Ripple	53
Figure 25.DAC Double-Speed Stopband Rejection	53
Figure 26.DAC Double-Speed Transition Band	53
Figure 27.DAC Double-Speed Transition Band	54
Figure 28.DAC Double-Speed Passband Ripple	54
Figure 29.DAC Quad-Speed Stopband Rejection	54
Figure 30.DAC Quad-Speed Transition Band	54
Figure 31.DAC Quad-Speed Transition Band	54
Figure 32.DAC Quad-Speed Passband Ripple	54
Figure 33.ADC Single-Speed Stopband Rejection	55
Figure 34.ADC Single-Speed Stopband Rejection	55
Figure 35.ADC Single-Speed Transition Band (Detail)	55
Figure 36.ADC Single-Speed Passband Ripple	55
Figure 37.ADC Double-Speed Stopband Rejection	55
Figure 38.ADC Double-Speed Stopband Rejection	55
Figure 39.ADC Double-Speed Transition Band (Detail)	56
Figure 40.ADC Double-Speed Passband Ripple	56
Figure 41.ADC Quad-Speed Stopband Rejection	56
Figure 42.ADC Quad-Speed Stopband Rejection	56
Figure 43.ADC Quad-Speed Transition Band (Detail)	56
Figure 44.ADC Quad-Speed Passband Ripple	56

LIST OF TABLES

Table 1. Speed Modes	30
Table 2. Common Clock Frequencies	31
Table 3. Slave Mode MCLK Dividers	31
Table 4. Slave Mode Serial Bit Clock Ratios	32
Table 5. Device Revision	42

Table 6. Freeze-able Bits	42
Table 7. Functional Mode Selection	43
Table 8. DAC Digital Interface Formats	43
Table 9. De-Emphasis Control	44
Table 10. Functional Mode Selection	44
Table 11. ADC Digital Interface Formats	45
Table 12. MCLK 1 Frequency	45
Table 13. MCLK 2 Frequency	46
Table 14. Auxiliary Output Source Selection	46
Table 15. Example Gain and Attenuation Settings	47
Table 16. PGA Soft Cross or Zero Cross Mode Selection	48
Table 17. Analog Input Multiplexer Selection	48
Table 18. Digital Volume Control Example Settings	49
Table 19. DAC Soft Cross or Zero Cross Mode Selection	49

1. PIN DESCRIPTIONS

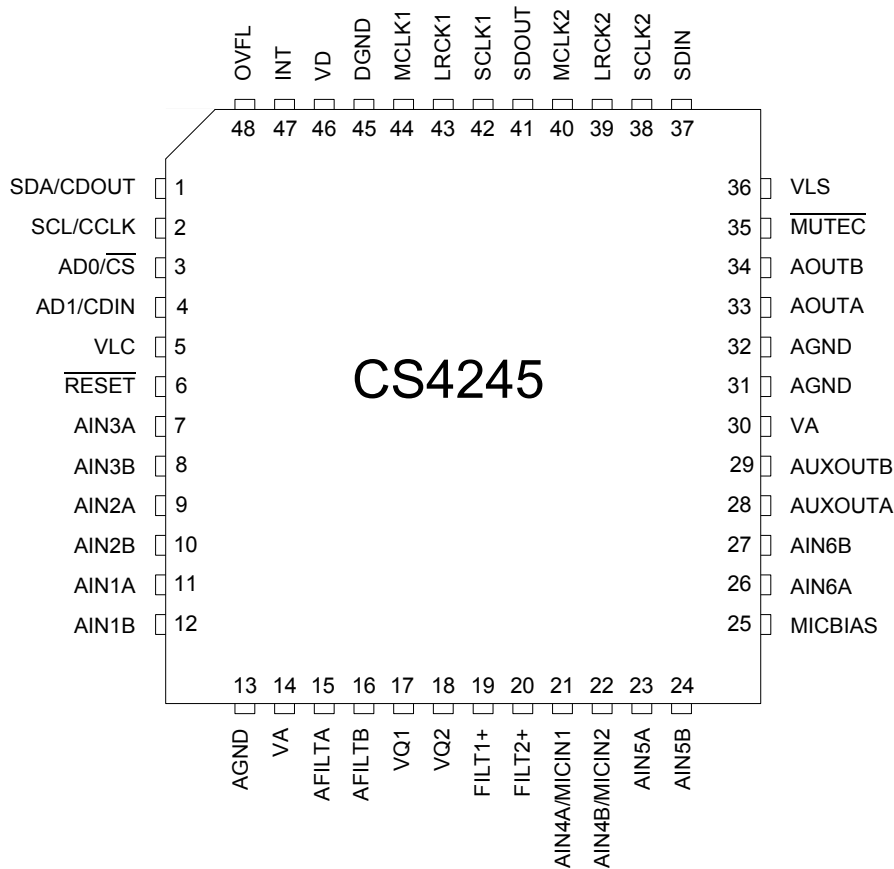

Pin Name	#	Pin Description
SDA/CDOUT	1	Serial Control Data (Input/Output) - SDA is a data I/O in I ² C Mode. CDOUT is the output data line for the control port interface in SPI Mode.
SCL/CCLK	2	Serial Control Port Clock (Input) - Serial clock for the serial control port.
AD0/ $\overline{\text{CS}}$	3	Address Bit 0 (I²C) / Control Port Chip Select (SPI) (Input) - AD0 is a chip address pin in I ² C Mode; CS is the chip-select signal for SPI format.
AD1/CDIN	4	Address Bit 1 (I²C) / Serial Control Data Input (SPI) (Input) - AD1 is a chip address pin in I ² C Mode; CDIN is the input data line for the control port interface in SPI Mode.
VLC	5	Control Port Power (Input) - Determines the required signal level for the control port interface. Refer to the Recommended Operating Conditions for appropriate voltages.
$\overline{\text{RESET}}$	6	Reset (Input) - The device enters a low power mode when this pin is driven low.
AIN3A AIN3B	7, 8	Stereo Analog Input 3 (Input) - The full-scale level is specified in the ADC Analog Characteristics specification table.
AIN2A AIN2B	9, 10	Stereo Analog Input 2 (Input) - The full-scale level is specified in the ADC Analog Characteristics specification table.
AIN1A AIN1B	11, 12	Stereo Analog Input 1 (Input) - The full-scale level is specified in the ADC Analog Characteristics specification table.

AGND	13	Analog Ground (Input) - Ground reference for the internal analog section.
VA	14	Analog Power (Input) - Positive power for the internal analog section.
AFILTA	15	Antialias Filter Connection (Output) - Antialias filter connection for the channel A ADC input.
AFILTB	16	Antialias Filter Connection (Output) - Antialias filter connection for the channel B ADC input.
VQ1	17	Quiescent Voltage 1 (Output) - Filter connection for the internal quiescent reference voltage.
VQ2	18	Quiescent Voltage 2 (Output) - Filter connection for the internal quiescent reference voltage.
FILT1+	19	Positive Voltage Reference 1 (Output) - Positive reference voltage for the internal sampling circuits.
FILT2+	20	Positive Voltage Reference 2 (Output) - Positive reference voltage for the internal sampling circuits.
AIN4A/MICIN1 AIN4B/MICIN2	21, 22	Stereo Analog Input 4 / Microphone Input 1 & 2 (Input) - The full-scale level is specified in the ADC Analog Characteristics specification table.
AIN5A AIN5B	23, 24	Stereo Analog Input 5 (Input) - The full-scale level is specified in the ADC Analog Characteristics specification table.
MICBIAS	25	Microphone Bias Supply (Output) - Low-noise bias supply for external microphone. Electrical characteristics are specified in the DC Electrical Characteristics specification table.
AIN6A AIN6B	26, 27	Stereo Analog Input 6 (Input) - The full-scale level is specified in the ADC Analog Characteristics specification table.
AUXOUTA AUXOUTB	28, 29	Auxiliary Analog Audio Output (Output) - Analog output from either the DAC, the PGA block, or high impedance. See “Auxiliary Output Source Select (Bits 6:5)” on page 46 .
VA	30	Analog Power (Input) - Positive power for the internal analog section.
AGND	31, 32	Analog Ground (Input) - Ground reference for the internal analog section.
AOUTA AOUTB	33, 34	DAC Analog Audio Output (Output) - The full-scale output level is specified in the DAC Analog Characteristics specification table.
MUTE \overline{C}	35	Mute Control (Output) - This pin is active during power-up initialization, reset, muting, when master clock to left/right clock frequency ratio is incorrect, or power-down.
VLS	36	Serial Audio Interface Power (Input) - Determines the required signal level for the serial audio interface. Refer to the Recommended Operating Conditions for appropriate voltages.
SDIN	37	Serial Audio Data Input (Input) - Input for two's complement serial audio data.
SCLK2	38	Serial Port 2 Serial Bit Clock (Input/Output) - Serial bit clock for serial audio interface 2.
LRCK2	39	Serial Port 2 Left Right Clock (Input/Output) - Determines which channel, Left or Right, is currently active on the serial audio input data line.
MCLK2	40	Master Clock 2 (Input) - Optional asynchronous clock source for the DAC's delta-sigma modulators.
SDOUT	41	Serial Audio Data Output (Output) - Output for two's complement serial audio data.
SCLK1	42	Serial Port 1 Serial Bit Clock (Input/Output) - Serial bit clock for serial audio interface 1.
LRCK1	43	Serial Port 1 Left Right Clock (Input/Output) - Determines which channel, Left or Right, is currently active on the serial audio output data line.
MCLK1	44	Master Clock 1 (Input) - Clock source for the ADC's delta-sigma modulators. By default, this signal also clocks the DAC's delta-sigma modulators.
DGND	45	Digital Ground (Input) - Ground reference for the internal digital section.
VD	46	Digital Power (Input) - Positive power for the internal digital section.
INT	47	Interrupt (Output) - Indicates an interrupt condition has occurred.
OVFL	48	ADC Overflow (Output) - Indicates an ADC overflow condition is present.

2. CHARACTERISTICS AND SPECIFICATIONS

SPECIFIED OPERATING CONDITIONS

AGND = DGND = 0 V; All voltages with respect to ground.

Parameters	Symbol	Min	Nom	Max	Units	
DC Power Supplies:	Analog	VA	3.13	5.0	5.25	V
	Digital	VD	3.13	3.3	(Note 1)	V
	Logic - Serial Port	VLS	1.71	3.3	5.25	V
	Logic - Control Port	VLC	1.71	3.3	5.25	V
Ambient Operating Temperature (Power Applied)	T _A	-10	-	+70	°C	

Notes: 1. Maximum of VA+0.25 V or 5.25 V, whichever is less.

ABSOLUTE MAXIMUM RATINGS

AGND = DGND = 0 V All voltages with respect to ground. (Note 2)

Parameter	Symbol	Min	Max	Units	
DC Power Supplies:	Analog	VA	-0.3	+6.0	V
	Digital	VD	-0.3	+6.0	V
	Logic - Serial Port	VLS	-0.3	+6.0	V
	Logic - Control Port	VLC	-0.3	+6.0	V
Input Current (Note 3)	I _{in}	-	±10	mA	
Analog Input Voltage	V _{INA}	AGND-0.3	VA+0.3	V	
Digital Input Voltage	Logic - Serial Port	V _{IND-S}	-0.3	VLS+0.3	V
	Logic - Control Port	V _{IND-C}	-0.3	VLC+0.3	V
Ambient Operating Temperature (Power Applied)	T _A	-50	+125	°C	
Storage Temperature	T _{stg}	-65	+150	°C	

- Operation beyond these limits may result in permanent damage to the device. Normal operation is not guaranteed at these extremes.
- Any pin except supplies. Transient currents of up to ±100 mA on the analog input pins will not cause SCR latch-up.

DAC ANALOG CHARACTERISTICS

Test Conditions (unless otherwise specified): AGND = DGND = 0 V; VA = 3.13 V to 5.25 V; VD = 3.13 V to 5.25 V or VA + 0.25 V, whichever is less; VLS = VLC = 1.71 V to 5.25 V; T_A = -10° to +70° C for Commercial or -40° to +85° C for Automotive; Output test signal: 997 Hz full-scale sine wave; Test load R_L = 3 kΩ, C_L = 10 pF (see Figure 1), F_s = 48/96/192 kHz. Measurement Bandwidth 10 Hz to 20 kHz Synchronous mode; All Connections as shown in Figure 12 on page 29.

Parameter	Symbol	Commercial Grade			Automotive Grade			Unit	
		Min	Typ	Max	Min	Typ	Max		
Dynamic Performance for VA = 4.75 V to 5.25 V									
Dynamic Range	(Note 4)								
18 to 24-Bit	A-Weighted	98	104	-	96	104	-	dB	
	unweighted	95	101	-	93	101	-	dB	
16-Bit	A-Weighted	90	96	-	88	96	-	dB	
	unweighted	87	93	-	85	93	-	dB	
Total Harmonic Distortion + Noise	(Note 4)								
18 to 24-Bit	0 dB	-	-90	-84	-	-90	-82	dB	
	-20 dB	-	-81	-	-	-81	-	dB	
	-60 dB	-	-41	-	-	-41	-	dB	
16-Bit	0 dB	-	-93	-87	-	-93	-85	dB	
	-20 dB	-	-73	-	-	-73	-	dB	
	-60 dB	-	-33	-	-	-33	-	dB	
Dynamic Performance for VA = 3.13 V to 3.46 V									
Dynamic Range	(Note 4)								
18 to 24-Bit	A-Weighted	95	101	-	93	101	-	dB	
	unweighted	92	98	-	90	98	-	dB	
16-Bit	A-Weighted	88	93	-	86	93	-	dB	
	unweighted	85	90	-	83	90	-	dB	
Total Harmonic Distortion + Noise	(Note 4)								
18 to 24-Bit	0 dB	-	-87	-79	-	-87	-77	dB	
	-20 dB	-	-78	-	-	-78	-	dB	
	-60 dB	-	-38	-	-	-38	-	dB	
16-Bit	0 dB	-	-90	-82	-	-90	-80	dB	
	-20 dB	-	-70	-	-	-70	-	dB	
	-60 dB	-	-30	-	-	-30	-	dB	
Interchannel Isolation	(1 kHz)	-	100	-	-	100	-	dB	
DC Accuracy									
Interchannel Gain Mismatch		-	0.1	0.25	-	0.1	0.25	dB	
Gain Drift		-	100	-	-	100	-	ppm/°C	
Analog Output									
Full Scale Output Voltage		0.60*VA	0.65*VA	0.70*VA	0.60*VA	0.65*VA	0.70*VA	V _{pp}	
DC Current draw from an AOUT pin	(Note 5)	I _{OUT}	-	-	10	-	-	10	μA
AC-Load Resistance	(Note 6)	R _L	3	-	-	3	-	-	kΩ
Load Capacitance	(Note 6)	C _L	-	-	100	-	-	100	pF
Output Impedance		Z _{OUT}	-	150	-	-	150	-	Ω

- One-half LSB of triangular PDF dither added to data.
- Guaranteed by design. The DC current draw represents the allowed current draw from the AOUT pin due to typical leakage through the electrolytic DC blocking capacitors.

6. Guaranteed by design. See Figure 2. R_L and C_L reflect the recommended minimum resistance and maximum capacitance required for the internal op-amp's stability. C_L affects the dominant pole of the internal output amp; increasing C_L beyond 100 pF can cause the internal op-amp to become unstable.

DAC COMBINED INTERPOLATION & ON-CHIP ANALOG FILTER RESPONSE

Parameter (Note 7,10)	Symbol	Min	Typ	Max	Unit
Combined Digital and On-chip Analog Filter Response		Single-Speed Mode			
Passband (Note 7)	to -0.1 dB corner to -3 dB corner	0	-	0.35	Fs
		0	-	0.4992	Fs
Frequency Response 10 Hz to 20 kHz		-0.175	-	+0.01	dB
StopBand		0.5465	-	-	Fs
StopBand Attenuation	(Note 8)	50	-	-	dB
Group Delay	tgd	-	10/Fs	-	s
De-emphasis Error (Note 9)	Fs = 44.1 kHz	-	-	+0.05/-0.25	dB
Combined Digital and On-chip Analog Filter Response		Double-Speed Mode			
Passband (Note 7)	to -0.1 dB corner to -3 dB corner	0	-	0.22	Fs
		0	-	0.501	Fs
Frequency Response 10 Hz to 20 kHz		-0.15	-	+0.15	dB
StopBand		0.5770	-	-	Fs
StopBand Attenuation	(Note 8)	55	-	-	dB
Group Delay	tgd	-	5/Fs	-	s
Combined Digital and On-chip Analog Filter Response		Quad-Speed Mode			
Passband (Note 7)	to -0.1 dB corner to -3 dB corner	0	-	0.110	Fs
		0	-	0.469	Fs
Frequency Response 10 Hz to 20 kHz		-0.12	-	0	dB
StopBand		0.7	-	-	Fs
StopBand Attenuation	(Note 8)	51	-	-	dB
Group Delay	tgd	-	2.5/Fs	-	s

7. Filter response is guaranteed by design.
8. For Single-Speed Mode, the Measurement Bandwidth is 0.5465 Fs to 3 Fs.
For Double-Speed Mode, the Measurement Bandwidth is 0.577 Fs to 1.4 Fs.
For Quad-Speed Mode, the Measurement Bandwidth is 0.7 Fs to 1 Fs.
9. De-emphasis is available only in Single-Speed Mode.
10. Response is clock dependent and will scale with Fs. Note that the amplitude vs. frequency plots of this data (Figures 21 to 30) have been normalized to Fs and can be de-normalized by multiplying the X-axis scale by Fs.

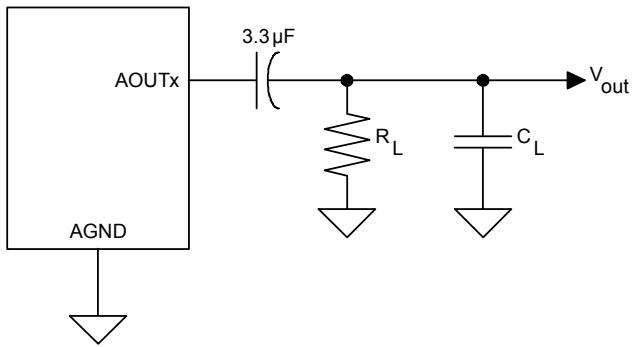

Figure 1. DAC Output Test Load

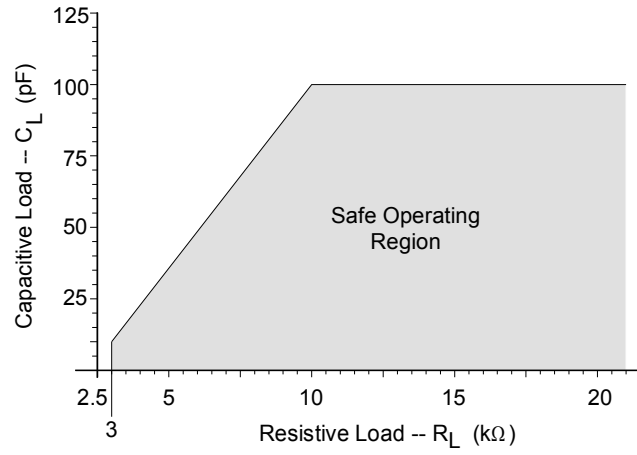

Figure 2. Maximum DAC Loading

ADC ANALOG CHARACTERISTICS

Test conditions (unless otherwise specified): AGND = DGND = 0 V; VA = 3.13 V to 5.25 V; VD = 3.13 V to 5.25 V or VA + 0.25 V, whichever is less; VLS = VLC = 1.71 V to 5.25 V; T_A = -10° to +70° C for Commercial or -40° to +85° C for Automotive; Input test signal: 1 kHz sine wave; measurement bandwidth is 10 Hz to 20 kHz; Fs = 48/96/192 kHz. Synchronous mode; All connections as shown in [Figure 12 on page 29](#).

Line-Level Inputs						
Parameter	Symbol	Min	Typ	Max	Unit	
Dynamic Performance for VA = 4.75 V to 5.25 V						
Dynamic Range (Note 13)	PGA Setting: -12 dB to +6 dB					
	A-weighted	98	104	-		dB
	unweighted	95	101	-		dB
	40 kHz bandwidth unweighted	-	98	-		dB
	PGA Setting: +12 dB Gain					
	A-weighted	92	98	-		dB
(Note 13)	unweighted	89	95	-		dB
	40 kHz bandwidth unweighted	-	92	-		dB
	Total Harmonic Distortion + Noise (Note 12)					
(Note 13)	PGA Setting: -12 dB to +6 dB					
	-1 dB	-	-95	-89		dB
	-20 dB	-	-81	-		dB
	-60 dB	-	-41	-		dB
	40 kHz bandwidth -1 dB	THD+N	-	-92	-	dB
	PGA Setting: +12 dB Gain					
(Note 13)	-1 dB	-	-92	-86		dB
	-20 dB	-	-75	-		dB
	-60 dB	-	-35	-		dB
	40 kHz bandwidth -1 dB	-	-89	-		dB
Dynamic Performance for VA = 3.13 V to 3.46 V						
Dynamic Range (Note 13)	PGA Setting: -12 dB to +6 dB					
	A-weighted	93	101	-		dB
	unweighted	90	98	-		dB
	40 kHz bandwidth unweighted	-	95	-		dB
	PGA Setting: +12 dB Gain					
	A-weighted	89	95	-		dB
(Note 13)	unweighted	86	92	-		dB
	40 kHz bandwidth unweighted	-	89	-		dB
	Total Harmonic Distortion + Noise (Note 12)					
(Note 13)	PGA Setting: -12 dB to +6 dB					
	-1 dB	-	-92	-86		dB
	-20 dB	-	-78	-		dB
	-60 dB	-	-38	-		dB
	40 kHz bandwidth -1 dB	THD+N	-	-84	-	dB
	PGA Setting: +12 dB Gain					
(Note 13)	-1 dB	-	-89	-83		dB
	-20 dB	-	-72	-		dB
	-60 dB	-	-32	-		dB
	40 kHz bandwidth -1 dB	-	-81	-		dB

Line-Level Inputs

Parameter	Symbol	Commercial Grade			Unit
		Min	Typ	Max	
Interchannel Isolation		-	90	-	dB

DC Accuracy					
Gain Error		-	-	±10	%
Gain Drift		-	±100	-	ppm/°C
Line-Level Input Characteristics					
Full-scale Input Voltage		0.51*VA	0.57*VA	0.63*VA	V _{pp}
Input Impedance	(Note 11)	6.12	6.8	7.48	kΩ
Maximum Interchannel Input Impedance Mismatch		-	5	-	%

Line-Level and Microphone-Level Inputs

Parameter	Symbol	Commercial Grade			Unit
		Min	Typ	Max	
DC Accuracy					
Interchannel Gain Mismatch		-	0.1	-	dB
Programmable Gain Characteristics					
Gain Step Size		-	0.5	-	dB
Absolute Gain Step Error		-	-	0.4	dB

11. Valid for the selected input pair.

ADC ANALOG CHARACTERISTICS

(Continued)

Microphone-Level Inputs								
Parameter	Symbol	Min	Typ	Max	Unit			
Dynamic Performance for VA = 4.75 V to 5.25 V								
Dynamic Range	PGA Setting: -12 dB to 0 dB		A-weighted	77	83	-	dB	
			unweighted	74	80	-	dB	
	PGA Setting: +12 dB		A-weighted	65	71	-	dB	
			unweighted	62	68	-	dB	
	Total Harmonic Distortion + Noise (Note 12)	PGA Setting: -12 dB to 0 dB	THD+N	-1 dB	-	-80	-74	dB
				-20 dB	-	-60	-	dB
-60 dB				-	-20	-	dB	
PGA Setting: +12 dB			-1 dB	-	-68	-	dB	
			Dynamic Performance for VA = 3.13 V to 3.46 V					
			Dynamic Range					
Dynamic Range	PGA Setting: -12 dB to 0 dB		A-weighted	77	83	-	dB	
			unweighted	74	80	-	dB	
	PGA Setting: +12 dB		A-weighted	65	71	-	dB	
			unweighted	62	68	-	dB	
	Total Harmonic Distortion + Noise (Note 12)	PGA Setting: -12 dB to 0 dB	THD+N	-1 dB	-	-80	-74	dB
				-20 dB	-	-60	-	dB
-60 dB				-	-20	-	dB	
PGA Setting: +12 dB			-1 dB	-	-68	-	dB	
			Interchannel Isolation					
				-	80	-	dB	
DC Accuracy								
Gain Error		-	±5	-	%			
Gain Drift		-	±300	-	ppm/°C			
Microphone-Level Input Characteristics								
Full-scale Input Voltage		0.013*VA	0.017*VA	0.021*VA	V _{pp}			
Input Impedance (Note 14)		-	60	-	kΩ			

12. Referred to the typical line-level full-scale input voltage

13. Valid for Double- and Quad-Speed Modes only.

14. Valid when the microphone-level inputs are selected.

ADC DIGITAL FILTER CHARACTERISTICS

Parameter (Notes 15, 17)	Symbol	Min	Typ	Max	Unit
Single-Speed Mode					
Passband (-0.1 dB)		0	-	0.4896	Fs
Passband Ripple		-	-	0.035	dB
Stopband		0.5688	-	-	Fs
Stopband Attenuation		70	-	-	dB
Total Group Delay (Fs = Output Sample Rate)	t_{gd}	-	12/Fs	-	s
Double-Speed Mode					
Passband (-0.1 dB)		0	-	0.4896	Fs
Passband Ripple		-	-	0.025	dB
Stopband		0.5604	-	-	Fs
Stopband Attenuation		69	-	-	dB
Total Group Delay (Fs = Output Sample Rate)	t_{gd}	-	9/Fs	-	s
Quad-Speed Mode					
Passband (-0.1 dB)		0	-	0.2604	Fs
Passband Ripple		-	-	0.025	dB
Stopband		0.5000	-	-	Fs
Stopband Attenuation		60	-	-	dB
Total Group Delay (Fs = Output Sample Rate)	t_{gd}	-	5/Fs	-	s
High-Pass Filter Characteristics					
Frequency Response	-3.0 dB	-	1	-	Hz
	-0.13 dB		20	-	Hz
Phase Deviation	@ 20 Hz		10	-	Deg
Passband Ripple		-	-	0	dB
Filter Settling Time			$10^5/Fs$		s

15. Filter response is guaranteed by design.

16. Response shown is for Fs = 48 kHz.

17. Response is clock-dependent and will scale with Fs. Note that the response plots (Figures 33 to 44) are normalized to Fs and can be de-normalized by multiplying the X-axis scale by Fs.

AUXILIARY OUTPUT ANALOG CHARACTERISTICS

Test conditions (unless otherwise specified): AGND = DGND = 0 V; VA = 3.13 V to 5.25 V; VD = 3.13 V to 5.25 V or VA + 0.25 V, whichever is less; VLS = VLC = 1.71 V to 5.25 V; T_A = -10° to +70° C for Commercial or -40° to +85° C for Automotive; Input test signal: 1 kHz sine wave; Measurement bandwidth: 10 Hz to 20 kHz; Fs = 48/96/192 kHz; Synchronous mode; All connections as shown in [Figure 12 on page 29](#).

VA = 4.75 V to 5.25 V								
Parameter	Symbol	Commercial Grade			Automotive Grade			Unit
		Min	Typ	Max	Min	Typ	Max	
Dynamic Performance with PGA Output Selected, Line Level Input								
Dynamic Range								
PGA Setting: -12 dB to +6 dB								
A-weighted		98	104	-	96	104	-	dB
unweighted		95	101	-	93	101	-	dB
PGA Setting: +12 dB Gain								
A-weighted		92	98	-	90	98	-	dB
unweighted		89	95	-	87	95	-	dB
Total Harmonic Distortion + Noise (Note 19)								
PGA Setting: -12 dB to +6 dB								
-1 dB	THD+N	-	-80	-74	-	-80	-72	dB
-20 dB		-	-81	-	-	-81	-	dB
-60 dB		-	-41	-	-	-41	-	dB
PGA Setting: +12 dB Gain								
-1 dB		-	-80	-74	-	-80	-72	dB
-20 dB		-	-75	-	-	-75	-	dB
-60 dB	-	-35	-	-	-35	-	dB	
Dynamic Performance with PGA Output Selected, Mic Level Input								
Dynamic Range								
PGA Setting: -12 dB to 0 dB								
A-weighted		77	83	-	75	83	-	dB
unweighted		74	80	-	72	80	-	dB
PGA Setting: +12 dB								
A-weighted		65	71	-	63	71	-	dB
unweighted		62	68	-	60	68	-	dB
Total Harmonic Distortion + Noise (Note 19)								
PGA Setting: -12 dB to 0 dB								
-1 dB	THD+N	-	-74	-68	-	-74	-66	dB
-20 dB		-	-60	-	-	-60	-	dB
-60 dB		-	-20	-	-	-20	-	dB
PGA Setting: +12 dB								
-1 dB	-	-68	-	-	-68	-	dB	
Dynamic Performance with DAC Output Selected								
Dynamic Range (Notes 18)								
18 to 24-Bit	A-weighted	98	104	-	96	104	-	dB
	unweighted	95	101	-	93	101	-	dB
16-Bit	A-Weighted	90	96	-	88	96	-	dB
	unweighted	87	93	-	85	93	-	dB
Total Harmonic Distortion + Noise (Notes 18, 20)								
18 to 24-Bit								
0 dB	THD+N	-	-80	-74	-	-80	-72	dB
-20 dB		-	-81	-	-	-81	-	dB
-60 dB		-	-41	-	-	-41	-	dB
16-Bit								
0 dB	-	-80	-74	-	-80	-72	dB	
-20 dB	-	-73	-	-	-73	-	dB	
-60 dB	-	-33	-	-	-33	-	dB	

AUXILIARY OUTPUT ANALOG CHARACTERISTICS

(Continued)

VA = 3.13 V to 3.46 V								
Parameter	Symbol	Commercial Grade			Automotive Grade			Unit
		Min	Typ	Max	Min	Typ	Max	
Dynamic Performance with PGA Output Selected, Line Level Input								
Dynamic Range								
PGA Setting: -12 dB to +6 dB								
A-weighted		93	101	-	91	101	-	dB
unweighted		90	98	-	88	98	-	dB
PGA Setting: +12 dB Gain								
A-weighted		89	95	-	87	95	-	dB
unweighted		86	92	-	84	92	-	dB
Total Harmonic Distortion + Noise (Note 19)								
PGA Setting: -12 dB to +6 dB								
-1 dB	THD+N	-	-80	-74	-	-80	-72	dB
-20 dB		-	-78	-	-	-78	-	dB
-60 dB		-	-38	-	-	-38	-	dB
PGA Setting: +12 dB Gain								
-1 dB		-	-80	-74	-	-80	-72	dB
-20 dB		-	-72	-	-	-72	-	dB
-60 dB		-	-32	-	-	-32	-	dB
Dynamic Performance with PGA Output Selected, Mic Level Input								
Dynamic Range								
PGA Setting: -12 dB to 0 dB								
A-weighted		77	83	-	75	83	-	dB
unweighted		74	80	-	72	80	-	dB
PGA Setting: +12 dB								
A-weighted		65	71	-	63	71	-	dB
unweighted		62	68	-	60	68	-	dB
Total Harmonic Distortion + Noise (Note 19)								
PGA Setting: -12 dB to 0 dB								
-1 dB	THD+N	-	-74	-68	-	-74	-66	dB
-20 dB		-	-60	-	-	-60	-	dB
-60 dB		-	-20	-	-	-20	-	dB
PGA Setting: +12 dB								
-1 dB		-	-68	-	-	-68	-	dB
Dynamic Performance with DAC Output Selected								
Dynamic Range (Notes 18)								
18 to 24-Bit	A-Weighted	95	101	-	93	101	-	dB
	unweighted	92	98	-	90	98	-	dB
16-Bit	A-Weighted	88	93	-	86	93	-	dB
	unweighted	85	90	-	83	90	-	dB
Total Harmonic Distortion + Noise (Notes 18, 20)								
18 to 24-Bit								
0 dB	THD+N	-	-80	-74	-	-80	-72	dB
-20 dB		-	-78	-	-	-78	-	dB
-60 dB		-	-38	-	-	-38	-	dB
16-Bit								
0 dB		-	-80	-74	-	-80	-72	dB
-20 dB		-	-70	-	-	-70	-	dB
-60 dB		-	-30	-	-	-30	-	dB

18. One-half LSB of triangular PDF dither added to data.

19. Referred to the typical Line-Level Full-Scale Input Voltage.

20. Referred to the typical DAC Full-Scale Output Voltage.

AUXILIARY OUTPUT ANALOG CHARACTERISTICS

(Continued)

VA = 3.13 V to 5.25 V								
Parameter	Symbol	Commercial Grade			Automotive Grade			Unit
		Min	Typ	Max	Min	Typ	Max	
DC Accuracy with PGA Output Selected, Line Level Input								
Interchannel Gain Mismatch		-	0.1	-	-	0.1	-	dB
Gain Error		-	±5	-	-	±5	-	%
Gain Drift		-	±100	-	-	±100	-	ppm/°C
DC Accuracy with PGA Output Selected, Mic Level Input								
Interchannel Gain Mismatch		-	0.3	-	-	0.3	-	dB
Gain Error		-	±5	-	-	±5	-	%
Gain Drift		-	±300	-	-	±300	-	ppm/°C
DC Accuracy with DAC Output Selected								
Interchannel Gain Mismatch		-	0.1	-	-	0.1	-	dB
Gain Drift		-	±100	-	-	±100	-	ppm/°C
Analog Output								
Frequency Response 10 Hz to 20 kHz	(Note 22)	-0.1dB	-	+0.1dB	-0.1dB	-	+0.1dB	dB
Analog In to Analog Out Phase Shift	(Note 21)	-	180	-	-	180	-	deg
DC Current draw from an AUXOUT pin	I _{OUT}	-	-	1	-	-	1	μA
AC-Load Resistance	R _L	100	-	-	100	-	-	kΩ
Load Capacitance	C _L	-	-	20	-	-	20	pF

21. Valid only when PGA output is selected.

22. Guaranteed by design.

DC ELECTRICAL CHARACTERISTICS

AGND = DGND = 0 V, all voltages with respect to ground. MCLK=12.288 MHz; Fs=48 kHz; Master Mode.

Parameter	Symbol	Min	Typ	Max	Unit	
Power Supply Current (Normal Operation)	VA = 5 V	IA	-	41	50	mA
	VA = 3.3 V	IA	-	37	45	mA
	VD, VLS, VLC = 5 V	ID	-	39	47	mA
	VD, VLS, VLC = 3.3 V	ID	-	23	28	mA
Power Supply Current (Power-Down Mode) (Note 23)	VA = 5 V	IA	-	0.50	-	mA
	VLS, VLC, VD=5 V	ID	-	0.54	-	mA
Power Consumption (Normal Operation)	VA, VD, VLS, VLC = 5 V	-	-	400	485	mW
	VA, VD, VLS, VLC = 3.3 V	-	-	198	241	mW
	(Power-Down Mode) VA, VD, VLS, VLC = 5 V	-	-	4.2	-	mW
Power Supply Rejection Ratio (1 kHz)	(Note 24)	PSRR	-	55	-	dB
VQ Characteristics						
Quiescent Voltage 1		VQ1	-	0.5 x VA	-	VDC
DC Current from VQ1	(Note 25)	IQ1	-	-	1	μA
VQ1 Output Impedance		ZQ1	-	23	-	kΩ
Quiescent Voltage 2		VQ2	-	0.5 x VA	-	VDC
DC Current from VQ2	(Note 25)	IQ2	-	-	1	μA
VQ2 Output Impedance		ZQ2	-	4.5	-	kΩ
FILT1+ Nominal Voltage		FILT1+	-	VA	-	VDC
FILT2+ Nominal Voltage		FILT2+	-	VA	-	VDC
Microphone Bias Voltage		MICBIAS	-	0.8 x VA	-	VDC
Current from MICBIAS		IMB	-	-	2	mA

23. Power-Down Mode is defines as $\overline{\text{RESET}} = \text{Low}$ with all clock and data lines held static and no analog input.
24. Valid with the recommended capacitor values on FILT1+, FILT2+, VQ1 and VQ2 as shown in the Typical Connection Diagram.
25. Guaranteed by design. The DC current draw represents the allowed current draw due to typical leakage through the electrolytic de-coupling capacitors.

DIGITAL INTERFACE CHARACTERISTICS

Test conditions (unless otherwise specified): AGND = DGND = 0 V; VLS = VLC = 1.71 V to 5.25 V.

Parameters (Note 26)	Symbol	Min	Typ	Max	Units
High-Level Input Voltage VL = 1.71 V Serial Port Control Port VL > 2.0 V Serial Port Control Port	V _{IH}	0.8xVLS	-	-	V
	V _{IH}	0.8xVLC	-	-	V
	V _{IH}	0.7xVLS	-	-	V
	V _{IH}	0.7xVLC	-	-	V
Low-Level Input Voltage Serial Port Control Port	V _{IL}	-	-	0.2xVLS	V
	V _{IL}	-	-	0.2xVLC	V
High-Level Output Voltage at I _o = 2 mA Serial Port Control Port MUTE C	V _{OH}	VLS-1.0	-	-	V
	V _{OH}	VLC-1.0	-	-	V
	V _{OH}	VA-1.0	-	-	V
Low-Level Output Voltage at I _o = 2 mA Serial Port Control Port MUTE C	V _{OL}	-	-	0.4	V
	V _{OL}	-	-	0.4	V
	V _{OL}	-	-	0.4	V
Input Leakage Current	I _{in}	-	-	±10	μA
Input Capacitance	(Note 27)	-	-	1	pF
Maximum MUTE C Drive Current		-	3	-	mA
Minimum OVFL Active Time		$\frac{10^6}{LRCK1}$	-	-	μs

26. Serial Port signals include: MCLK1, MCLK2, SCLK1, SCLK2, LRCK1, LRCK2, SDIN, SDOUT.
Control Port signals include: SCL/CCLK, SDA/CDOUT, AD0/CS, AD1/CDIN, RESET, INT, OVFL.

27. Guaranteed by design.

SWITCHING CHARACTERISTICS - SERIAL AUDIO PORT 1

Logic '0' = DGND = AGND = 0 V; Logic '1' = VL, C_L = 20 pF. (Note 28)

Parameter	Symbol	Min	Typ	Max	Unit	
Sample Rate	Single Speed Mode	F _s	4	-	50	kHz
	Double Speed Mode	F _s	50	-	100	kHz
	Quad Speed Mode	F _s	100	-	200	kHz
MCLK Specifications						
MCLK1 Input Frequency	fmclk	1.024	-	51.200	MHz	
MCLK1 Input Pulse Width High/Low	tcclkhl	8	-	-	ns	
Master Mode						
LRCK1 Duty Cycle		-	50	-	%	
SCLK1 Duty Cycle		-	50	-	%	
SCLK1 falling to LRCK1 edge	t _{slr}	-10	-	10	ns	
SCLK1 falling to SDOUT valid	t _{sdo}	0	-	36	ns	
Slave Mode						
LRCK1 Duty Cycle		40	50	60	%	
SCLK1 Period	Single-Speed Mode	t _{sclkw}	$\frac{10^9}{(128)F_s}$	-	-	ns
	Double-Speed Mode	t _{sclkw}	$\frac{10^9}{(64)F_s}$	-	-	ns
	Quad-Speed Mode	t _{sclkw}	$\frac{10^9}{(64)F_s}$	-	-	ns
SCLK1 Pulse Width High	t _{sclkh}	30	-	-	ns	
SCLK1 Pulse Width Low	t _{sclkl}	48	-	-	ns	
SCLK1 falling to LRCK1 edge	t _{slr}	-10	-	10	ns	
SCLK1 falling to SDOUT valid	t _{sdo}	0	-	36	ns	

28. See Figure 3 and Figure 4 on page 23.

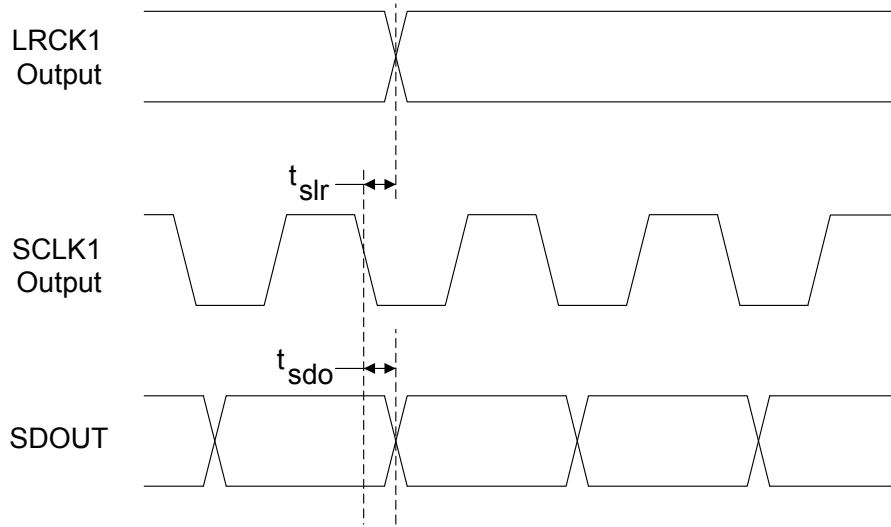

Figure 3. Master Mode Timing - Serial Audio Port 1

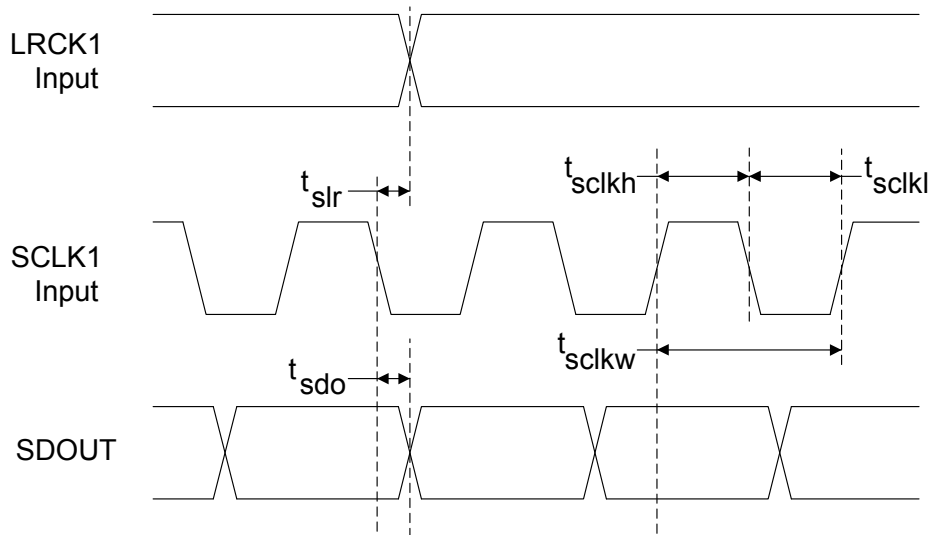

Figure 4. Slave Mode Timing - Serial Audio Port 1

SWITCHING CHARACTERISTICS - SERIAL AUDIO PORT 2

Logic '0' = DGND = AGND = 0 V; Logic '1' = VL, C_L = 20 pF. (Note 29)

Parameter	Symbol	Min	Typ	Max	Unit	
Sample Rate	Single Speed Mode	F _s	4	-	50	kHz
	Double Speed Mode	F _s	50	-	100	kHz
	Quad Speed Mode	F _s	100	-	200	kHz
MCLK Specifications						
MCLK2 Input Frequency	f _{mclk}	1.024	-	51.200	MHz	
MCLK2 Input Pulse Width High/Low	t _{clkh}	8	-	-	ns	
Master Mode						
LRCK2 Duty Cycle		-	50	-	%	
SCLK2 Duty Cycle		-	50	-	%	
SCLK2 falling to LRCK edge	t _{slr}	-10	-	10	ns	
SDIN valid to SCLK2 rising setup time	t _{sdis}	16	-	-	ns	
SCLK2 rising to SDIN hold time	t _{sdi}	20	-	-	ns	
Slave Mode						
LRCK2 Duty Cycle		40	50	60	%	
SCLK2 Period	Single-Speed Mode	t _{sclw}	$\frac{10^9}{(128)F_s}$	-	-	ns
	Double-Speed Mode	t _{sclw}	$\frac{10^9}{(64)F_s}$	-	-	ns
	Quad-Speed Mode	t _{sclw}	$\frac{10^9}{(64)F_s}$	-	-	ns
SCLK2 Pulse Width High	t _{sclh}	30	-	-	ns	
SCLK2 Pulse Width Low	t _{scll}	48	-	-	ns	
SCLK2 falling to LRCK2 edge	t _{slr}	-10	-	10	ns	
SDIN valid to SCLK2 rising setup time	t _{sdis}	16	-	-	ns	
SCLK2 rising to SDIN hold time	t _{sdi}	20	-	-	ns	

29. See Figure 5 and Figure 6 on page 25.

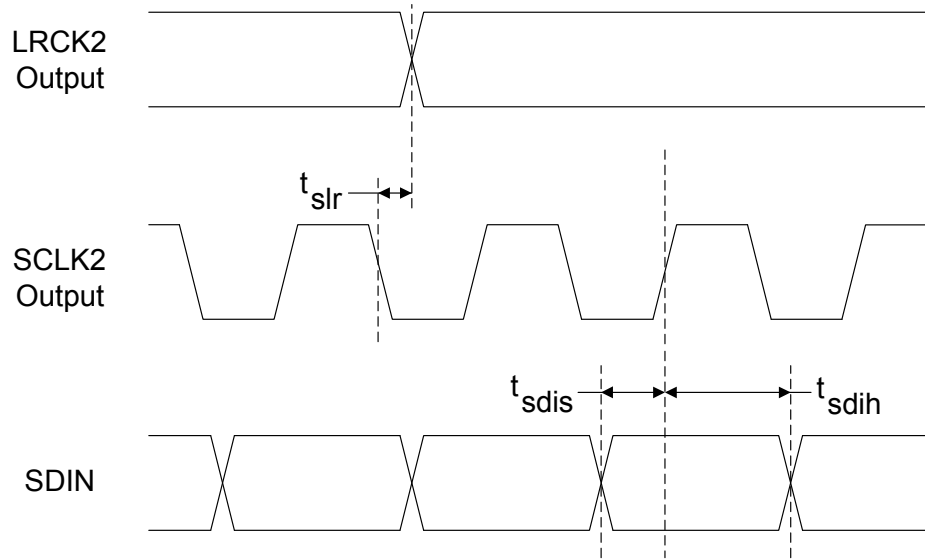

Figure 5. Master Mode Timing - Serial Audio Port 2

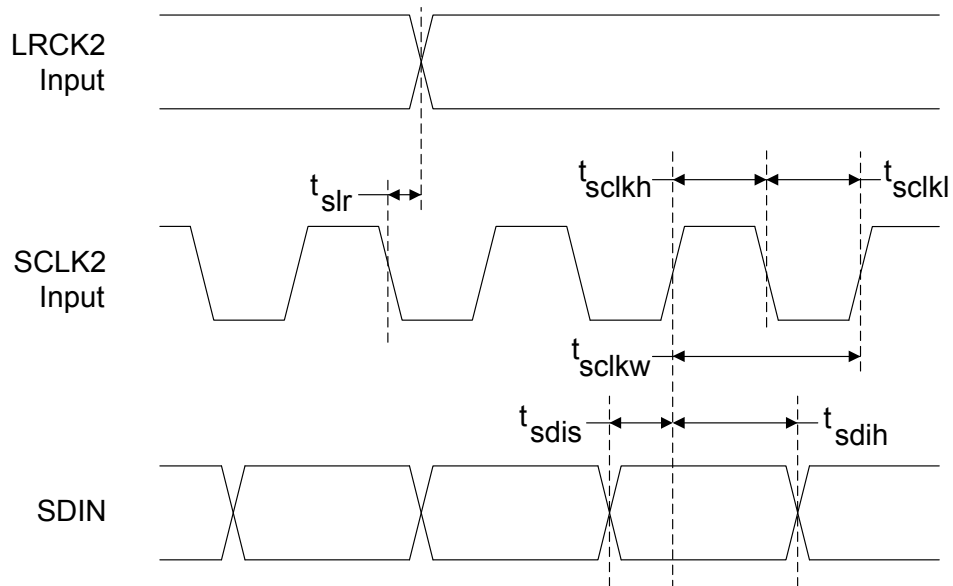

Figure 6. Slave Mode Timing - Serial Audio Port 2

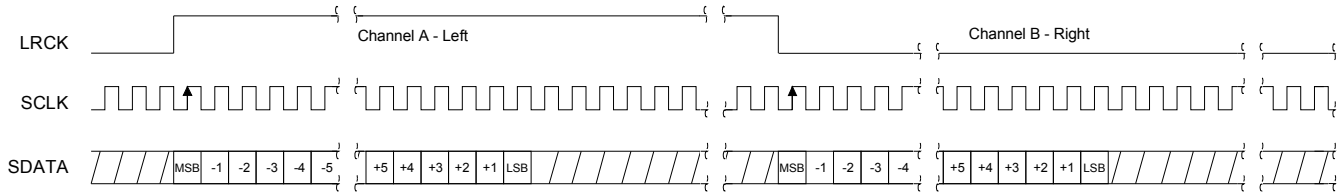

Figure 7. Format 0, Left-Justified up to 24-Bit Data

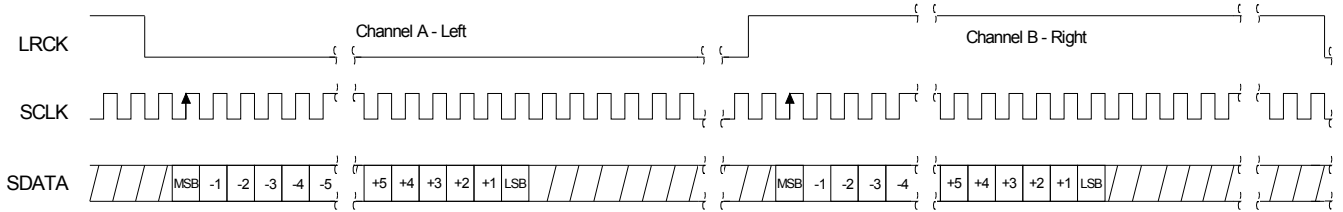
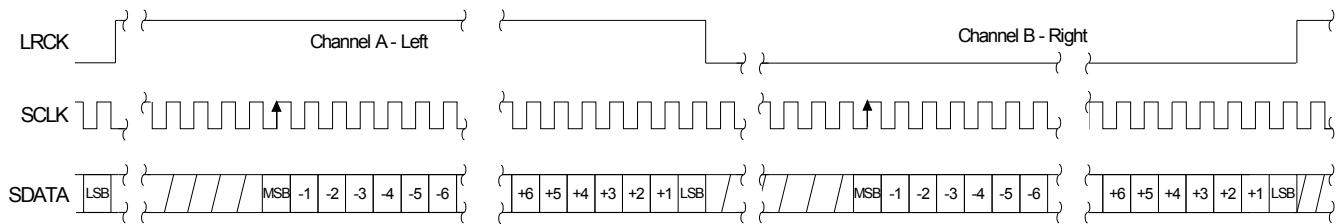

Figure 8. Format 1, I²S up to 24-Bit Data



**Figure 9. Format 2, Right-Justified 16-Bit Data.
Format 3, Right-Justified 24-Bit Data.**

SWITCHING CHARACTERISTICS - CONTROL PORT - I²C FORMAT

Inputs: Logic 0 = DGND = AGND = 0 V, Logic 1 = VLC, C_L = 30 pF.

Parameter	Symbol	Min	Max	Unit
SCL Clock Frequency	f _{scl}	-	100	kHz
RESET Rising Edge to Start	t _{irs}	500	-	ns
Bus Free Time Between Transmissions	t _{buf}	4.7	-	μs
Start Condition Hold Time (prior to first clock pulse)	t _{hdst}	4.0	-	μs
Clock Low time	t _{low}	4.7	-	μs
Clock High Time	t _{high}	4.0	-	μs
Setup Time for Repeated Start Condition	t _{sust}	4.7	-	μs
SDA Hold Time from SCL Falling	(Note 30) t _{hdd}	0	-	μs
SDA Setup time to SCL Rising	t _{sud}	250	-	ns
Rise Time of SCL and SDA	(Note 31) t _{rc} , t _{rd}	-	1	μs
Fall Time SCL and SDA	(Note 31) t _{fc} , t _{fd}	-	300	ns
Setup Time for Stop Condition	t _{susp}	4.7	-	μs
Acknowledge Delay from SCL Falling	t _{ack}	300	1000	ns

30. Data must be held for sufficient time to bridge the transition time, t_{fc}, of SCL.

31. Guaranteed by design.

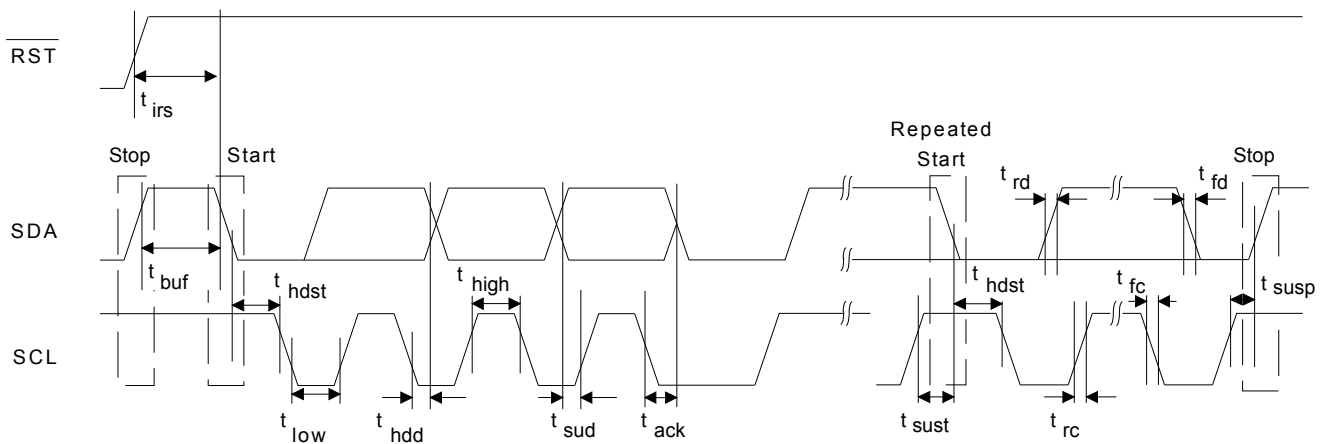

Figure 10. Control Port Timing - I²C Format

SWITCHING CHARACTERISTICS - CONTROL PORT - SPI FORMAT

Inputs: Logic 0 = DGND = AGND = 0 V, Logic 1 = VLC, $C_L = 30$ pF.

Parameter	Symbol	Min	Max	Units
CCLK Clock Frequency	f_{sck}	-	6.0	MHz
$\overline{\text{RESET}}$ Rising Edge to $\overline{\text{CS}}$ Falling	t_{srs}	500	-	ns
$\overline{\text{CS}}$ High Time Between Transmissions	t_{csh}	1.0	-	μs
$\overline{\text{CS}}$ Falling to CCLK Edge	t_{css}	20	-	ns
CCLK Low Time	t_{scl}	66	-	ns
CCLK High Time	t_{sch}	66	-	ns
CDIN to CCLK Rising Setup Time	t_{dsu}	40	-	ns
CCLK Rising to DATA Hold Time	t_{dh}	15	-	ns
CCLK Falling to CDOUT Stable	t_{pd}	-	50	ns
Rise Time of CDOUT	t_{r1}	-	25	ns
Fall Time of CDOUT	t_{f1}	-	25	ns
Rise Time of CCLK and CDIN	t_{r2}	-	100	ns
Fall Time of CCLK and CDIN	t_{f2}	-	100	ns

32. Data must be held for sufficient time to bridge the transition time of CCLK.

33. For $f_{sck} < 1$ MHz.

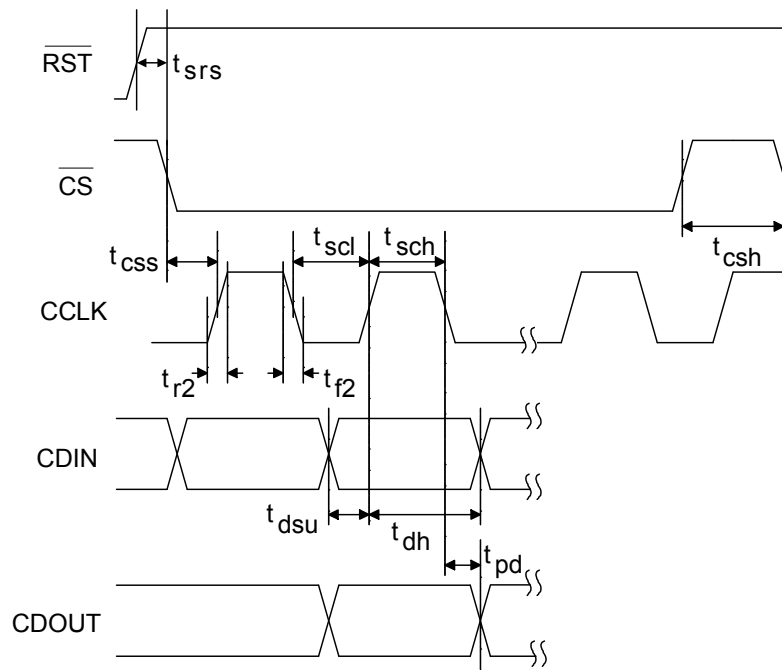
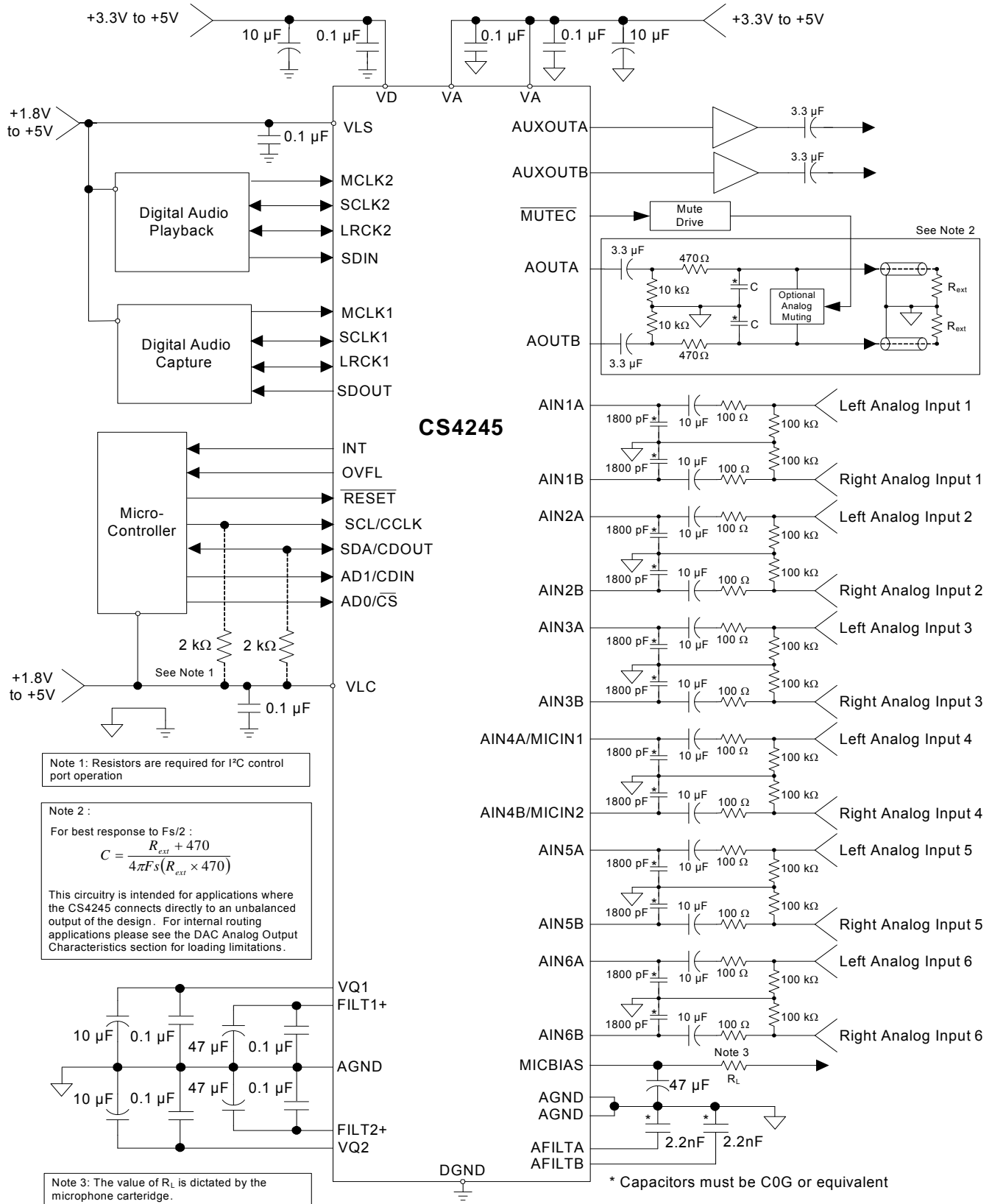

Figure 11. Control Port Timing - SPI Format

3. TYPICAL CONNECTION DIAGRAM

Figure 12. Typical Connection Diagram

4. APPLICATIONS

4.1 Recommended Power-Up Sequence

1. Hold $\overline{\text{RESET}}$ low until the power supply, MCLK1, MCLK2 (if used), LRCK1 and LRCK2 are stable. In this state, the Control Port is reset to its default settings.
2. Bring $\overline{\text{RESET}}$ high. The device will remain in a low power state with the PDN bit set by default. The control port will be accessible.
3. The desired register settings can be loaded while the PDN bit remains set.
4. Clear the PDN bit to initiate the power-up sequence.

4.2 System Clocking

The CS4245 will operate at sampling frequencies from 4 kHz to 200 kHz. This range is divided into three speed modes as shown in [Table 1](#).

Mode	Sampling Frequency
<i>Single-Speed</i>	4-50 kHz
<i>Double-Speed</i>	50-100 kHz
<i>Quad-Speed</i>	100-200 kHz

Table 1. Speed Modes

The CS4245 has two serial ports which may be operated synchronously or asynchronously. Serial port 1 consists of the SCLK1 and LRCK1 signals and clocks the serial audio output, SDOUT. Serial port 2 consists of the SCLK2 and LRCK2 signals and clocks the serial audio input, SDIN.

Each serial port may be independently placed into Single, Double, or Quad Speed mode. The serial ports may also be independently placed into Master or Slave mode.

4.2.1 Synchronous / Asynchronous Mode

By default, the CS4245 operates in Synchronous Mode with both serial ports synchronous to MCLK1. In this mode, the serial ports may operate at different synchronous rates as set by the ADC_FM and DAC_FM bits, and MCLK2 does not need to be provided (the MCLK2 pin may be left unconnected).

If the Asynch bit is set (see [“Asynchronous Mode \(Bit 0\)” on page 46](#)), the CS4245 will operate in asynchronous mode. The serial ports will operate asynchronously with Serial Port 1 clocked from MCLK1 and Serial Port 2 clocked from MCLK2. In this mode, the serial ports may operate at different asynchronous rates.

4.2.2 Master Clock

In Asynchronous Mode, MCLK1/LRCK1 and MCLK2/LRCK2 must maintain an integer ratio. In synchronous mode MCLK1/LRCK1 and MCLK1/LRCK2 must maintain an integer ratio. Some common ratios are shown in [Table 2](#). The LRCK frequency is equal to F_s , the frequency at which audio samples for each channel are clocked into or out of the device. The ADC_FM and DAC_FM bits and the MCLK Freq bits (See [“MCLK Frequency - Address 05h” on page 45](#).) configure the device to generate the proper clocks

in Master Mode, and receive the proper clocks in Slave Mode. [Table 2](#) illustrates several standard audio sample rates and the required MCLK and LRCK frequencies.

LRCK (kHz)	MCLK (MHz)								
	64x	96x	128x	192x	256x	384x	512x	768x	1024x
32	-	-	-	-	8.1920	12.2880	16.3840	24.5760	32.7680
44.1	-	-	-	-	11.2896	16.9344	22.5792	33.8680	45.1584
48	-	-	-	-	12.2880	18.4320	24.5760	36.8640	49.1520
64	-	-	8.1920	12.2880	16.3840	24.5760	32.7680	-	-
88.2	-	-	11.2896	16.9344	22.5792	33.8680	45.1584	-	-
96	-	-	12.2880	18.4320	24.5760	36.8640	49.1520	-	-
128	8.1920	12.2880	16.3840	24.5760	32.7680	-	-	-	-
176.4	11.2896	16.9344	22.5792	33.8680	45.1584	-	-	-	-
192	12.2880	18.4320	24.5760	36.8640	49.1520	-	-	-	-
Mode	QSM					DSM		SSM	

Table 2. Common Clock Frequencies

In both Master and Slave Modes, the external MCLK must be divided down based on the MCLK/LRCK ratio to achieve a post-divider MCLK/LRCK ratio of 256x for SSM, 128x for DSM, or 64x for QSM. [Table 3](#) lists the appropriate dividers.

MCLK/LRCK Ratio	MCLK Dividers		
64x	-	-	÷1
96x	-	-	÷1.5
128x	-	÷1	÷2
192x	-	÷1.5	÷3
256x	÷1	÷2	÷4
384x	÷1.5	÷3	-
512x	÷2	÷4	-
768x	÷3	-	-
1024x	÷4	-	-
Mode	SSM	DSM	QSM

Table 3. MCLK Dividers

4.2.3 Master Mode

As a clock master, LRCK and SCLK will operate as outputs. The two serial ports may be independently placed into Master or Slave mode. Each LRCK and SCLK is internally derived from its respective MCLK with LRCK equal to F_s and SCLK equal to $64 \times F_s$ as shown in Figure 13.

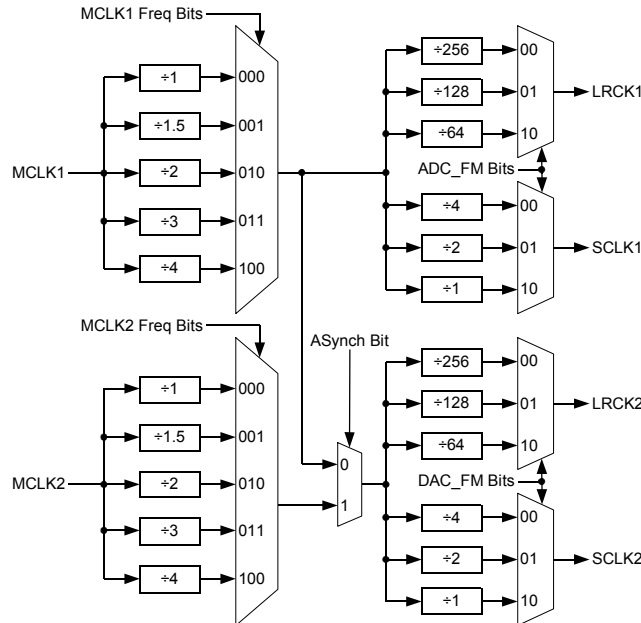

Figure 13. Master Mode Clocking

4.2.4 Slave Mode

In Slave Mode, SCLK and LRCK operate as inputs. Each serial port may be independently placed into Slave Mode. The Left/Right clock signal must be equal to the sample rate, F_s . If operating in Asynchronous Mode, LRCK1 must be synchronously derived from MCLK1 and LRCK2 must be synchronously derived from MCLK2. If operating in Synchronous Mode, LRCK1, and LRCK2 must be synchronously derived from MCLK1. For more information on Synchronous and Asynchronous Modes, see “Synchronous / Asynchronous Mode” on page 30.

For each serial port, the serial bit clock must be equal to $128x$, $64x$, $48x$ or $32x F_s$, depending on the desired speed mode. If operating in Asynchronous Mode, the serial bit clock SCLK1 must be synchronously derived from MCLK1 and SCLK2 must be synchronously derived from MCLK2. If operating in Synchronous Mode, SCLK1, and SCLK2 must be synchronously derived from MCLK1. Refer to Table 4 for required serial bit clock to Left/Right clock ratios.

	Single-Speed	Double-Speed	Quad-Speed
SCLK/LRCK Ratio	32x, 48x, 64x, 128x	32x, 48x, 64x	32x, 48x, 64x

Table 4. Slave Mode Serial Bit Clock Ratios

4.3 High-Pass Filter and DC Offset Calibration

When using operational amplifiers in the input circuitry driving the CS4245, a small DC offset may be driven into the A/D converter. The CS4245 includes a high-pass filter after the decimator to remove any DC offset which could result in recording a DC level, possibly yielding clicks when switching between devices in a multichannel system.

The high-pass filter continuously subtracts a measure of the DC offset from the output of the decimation filter. If the HPFFreeze bit (See [“ADC High-Pass Filter Freeze \(Bit 1\)” on page 45.](#)) is set during normal operation, the current value of the DC offset for the each channel is frozen and this DC offset will continue to be subtracted from the conversion result. This feature makes it possible to perform a system DC offset calibration by:

1. Running the CS4245 with the high-pass filter enabled until the filter settles. See the ADC Digital Filter Characteristics section for filter settling time.
2. Disabling the high-pass filter and freezing the stored DC offset.

A system calibration performed in this way will eliminate offsets anywhere in the signal path between the calibration point and the CS4245.

4.4 Analog Input Multiplexer, PGA, and Mic Gain

The CS4245 contains a stereo 6-to-1 analog input multiplexer followed by a programmable gain amplifier (PGA). The input multiplexer can select one of six possible stereo analog input sources and route it to the PGA. Analog inputs 4A and 4B are able to insert a +32 dB gain stage before the input multiplexer, allowing them to be used for microphone-level signals without the need for any external gain. The PGA stage provides ± 12 dB of gain or attenuation in 0.5 dB steps. Figure 14 shows the architecture of the input multiplexer, PGA, and microphone gain stages.

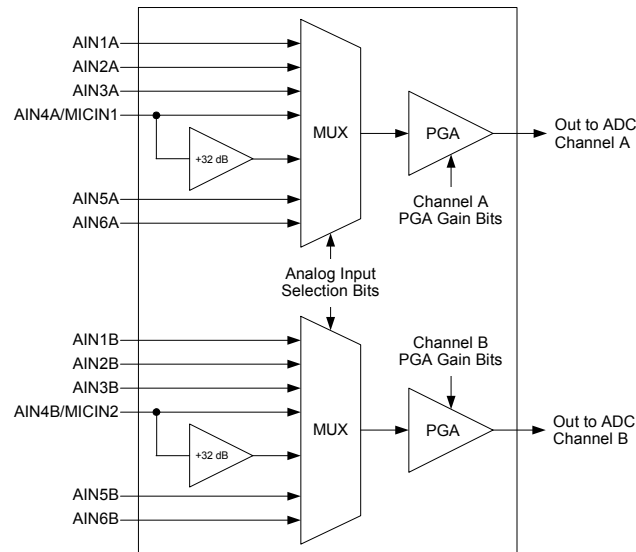

Figure 14. Analog Input Architecture

The “[Analog Input Selection \(Bits 2:0\)](#)” on page 48 outlines the bit settings necessary to control the input multiplexer and mic gain. “[Channel B PGA Control - Address 07h](#)” on page 47 and “[Channel A PGA Control - Address 08h](#)” on page 47 outline the register settings necessary to control the PGA. By default, line-level input 1 is selected, and the PGA is set to 0 dB.

4.5 Input Connections

The analog modulator samples the input at 6.144 MHz (MCLK=12.288 MHz). The digital filter will reject signals within the stopband of the filter. However, there is no rejection for input signals which are $(n \times 6.144 \text{ MHz})$ the digital passband frequency, where $n=0,1,2,\dots$. Refer to the Typical Connection Diagram for the recommended analog input circuit that will attenuate noise energy at 6.144 MHz. The use of capacitors which have a large voltage coefficient (such as general-purpose ceramics) must be avoided since these can degrade signal linearity. Any unused analog input pairs should be left unconnected.

4.6 Output Connections

The CS4245 DACs implement a switched-capacitor filter, followed by a continuous time low-pass filter. Its response, combined with that of the digital interpolator, is shown in [Section 8. “DAC Filter Plots” on page 53](#). The recommended external analog circuitry is shown in the Typical Connection Diagram.

The CS4245 DAC does not include phase or amplitude compensation for an external filter. Therefore, the DAC system phase and amplitude response is dependent on the external analog circuitry.

4.7 Output Transient Control

The CS4245 uses Popguard® technology to minimize the effects of output transients during power-up and power-down. This technique eliminates the audio transients commonly produced by single-ended, single-supply converters when it is implemented with external DC-blocking capacitors connected in series with the audio outputs. To make best use of this feature, it is necessary to understand its operation.

4.7.1 Power-Up

When the device is initially powered-up, the audio outputs AOUTA and AOUTB are clamped to VQ2, which is initially low. After the PDN bit is released (set to '0'), the DAC outputs begin to ramp with VQ2 towards the nominal quiescent voltage. This ramp takes approximately 200 ms to complete. The gradual voltage ramping allows time for the external DC-blocking capacitors to charge to VQ2, effectively blocking the quiescent DC voltage. Audio output will begin after approximately 2000 sample periods.

4.7.2 Power-Down

To prevent audio transients at power-down, the DC-blocking capacitors must fully discharge before turning off the power. In order to do this, either the PDN bit should be set or the device should be reset about 250 ms before removing power. During this time, the voltage on VQ2 and the DAC outputs discharge gradually to GND. If power is removed before this 250 ms time period has passed, a transient will occur when the VA supply drops below that of VQ2. There is no minimum time for a power cycle; power may be re-applied at any time.

4.7.3 Serial Interface Clock Changes

When changing the DAC clock ratio or sample rate, it is recommended that zero data (or near zero data) be present on SDIN for at least 10 LRCK samples before the change is made. During the clocking change, the DAC outputs will always be in a zerodata state. If non-zero serial audio input is present at the time of switching, a slight click or pop may be heard as the DAC output automatically goes to its zero data state.

4.8 Auxiliary Analog Output

The CS4245 includes an auxiliary analog output through the AUXOUT pins. These pins can be configured to output the analog input to the ADC as selected with the input MUX and gained or attenuated with the PGA, the analog output of the DAC, or alternatively they may be set to high-impedance. See [“Section 6.6.1 “Auxiliary Output Source Select \(Bits 6:5\)” on page 46”](#) for information on configuring the auxiliary analog output.

The auxiliary analog output can source very little current. As current from the AUXOUT pins increases, distortion will increase. For this reason, a high input impedance buffer must be used on the AUXOUT pins to achieve full performance. Refer to the table in [“Auxiliary Output Analog Characteristics” on page 17](#) for acceptable loading conditions.

4.9 De-Emphasis Filter

The CS4245 includes on-chip digital de-emphasis optimized for a sample rate of 44.1 kHz. The filter response is shown in [Figure 15](#). The frequency response of the de-emphasis curve scales proportionally with changes in sample rate, Fs. Please see [Section 6.3.4 “De-Emphasis Control \(Bit 1\)” on page 44](#) for de-emphasis control.

The de-emphasis feature is included to accommodate audio recordings that utilize 50/15 μ s pre-emphasis equalization as a means of noise reduction.

De-emphasis is only available in Single-Speed Mode.

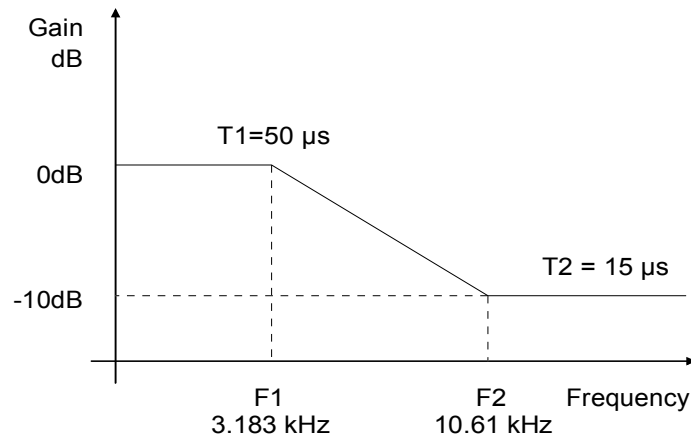

Figure 15. De-Emphasis Curve

4.10 Internal Digital Loopback

The CS4245 supports an internal digital loopback mode in which the output of the ADC is routed to the input of the DAC. This mode may be activated by setting the LOOP bit in the Signal Selection register (See [Section 6.6 “Signal Selection - Address 06h” on page 46](#)). To use this mode, the ADC and DAC must be operating at the same synchronous sample rate.

When this bit is set, the status of the DAC_DIF[1:0] bits in register 03h will be disregarded by the CS4245. Any changes made to the DAC_DIF[1:0] bits while the LOOP bit is set will have no impact on operation until the LOOP bit is cleared, at which time the Digital Interface Format of the DAC will operate according to the format selected by the DAC_DIF[1:0] bits. While the LOOP bit is set, data will be present on the SDOOUT pin in the format selected by the ADC_DIF bit in register 04h.

4.11 Mute Control

The MUTE pin becomes active during power-up initialization, reset, and muting if the MCLK2 to LRCK2 ratio is incorrect in Asynchronous Mode or the MCLK1 to LRCK2 ratio is incorrect in Synchronous Mode, and during power-down. The MUTE pin is intended to be used as control for an external mute circuit in order to add off-chip mute capability.

Use of the Mute Control function is not mandatory, but recommended, for designs requiring the absolute minimum in extraneous clicks and pops. Also, use of the Mute Control function can enable the system de-

signer to achieve idle channel noise/signal-to-noise ratios which are only limited by the external mute circuit. The MUTE \overline{C} pin is an active-low CMOS driver. See Figure 16 for a suggested active-low mute circuit.

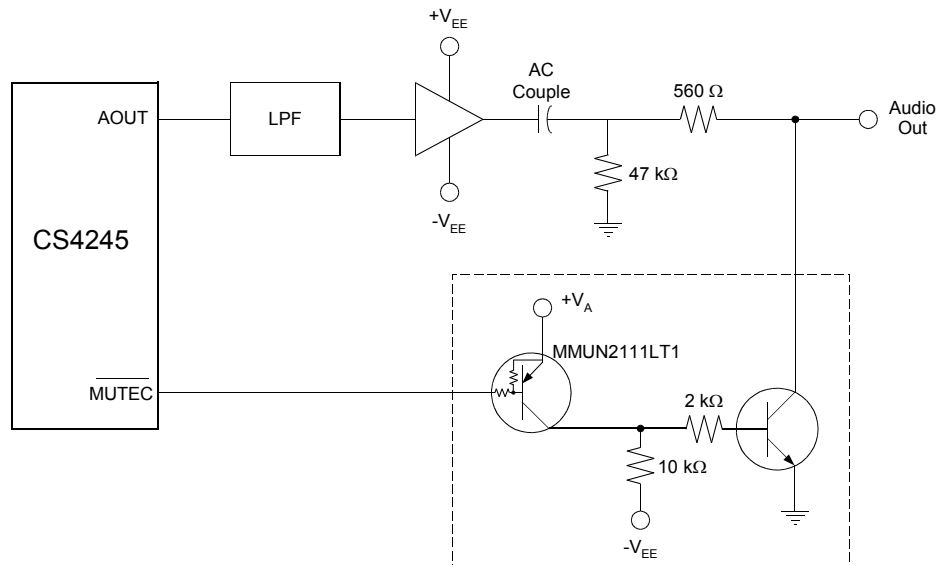

Figure 16. Suggested Active-Low Mute Circuit

4.12 Control Port Description and Timing

The control port is used to access the registers, allowing the CS4245 to be configured for the desired operational modes and formats. The operation of the control port may be completely asynchronous with respect to the audio sample rates. However, to avoid potential interference problems, the control port pins should remain static if no operation is required.

The control port has two modes: SPI and I²C, with the CS4245 acting as a slave device. SPI Mode is selected if there is a high-to-low transition on the AD0/ \overline{CS} pin, after the \overline{RESET} pin has been brought high. I²C Mode is selected by connecting the AD0/ \overline{CS} pin through a resistor to VLC or DGND, thereby permanently selecting the desired AD0 bit address state.

4.12.1 SPI Mode

In SPI Mode, \overline{CS} is the CS4245 chip-select signal; CCLK is the control port bit clock (input into the CS4245 from the microcontroller); CDIN is the input data line from the microcontroller; CDOUT is the output data line to the microcontroller. Data is clocked in on the rising edge of CCLK and out on the falling edge.

Figure 17 shows the operation of the control port in SPI Mode. To write to a register, bring \overline{CS} low. The first seven bits on CDIN form the chip address and must be 1001111. The eighth bit is a read/write indicator ($\overline{R/W}$), which should be low to write. The next eight bits form the Memory Address Pointer (MAP), which is set to the address of the register that is to be updated. The next eight bits are the data that will be placed into the register designated by the MAP. During writes, the CDOUT output stays in the Hi-Z state. It may be externally pulled high or low with a 47 k Ω resistor, if desired.

To read a register, the MAP has to be set to the correct address by executing a partial write cycle which finishes (\overline{CS} high) immediately after the MAP byte. To begin a read, bring \overline{CS} low, send out the chip ad-

dress and set the read/write bit ($\overline{R/W}$) high. The next falling edge of CCLK will clock out the MSB of the addressed register (CDOU will leave the high-impedance state).

For both read and write cycles, the memory address pointer will automatically increment following each data byte in order to facilitate block reads and writes of successive registers.

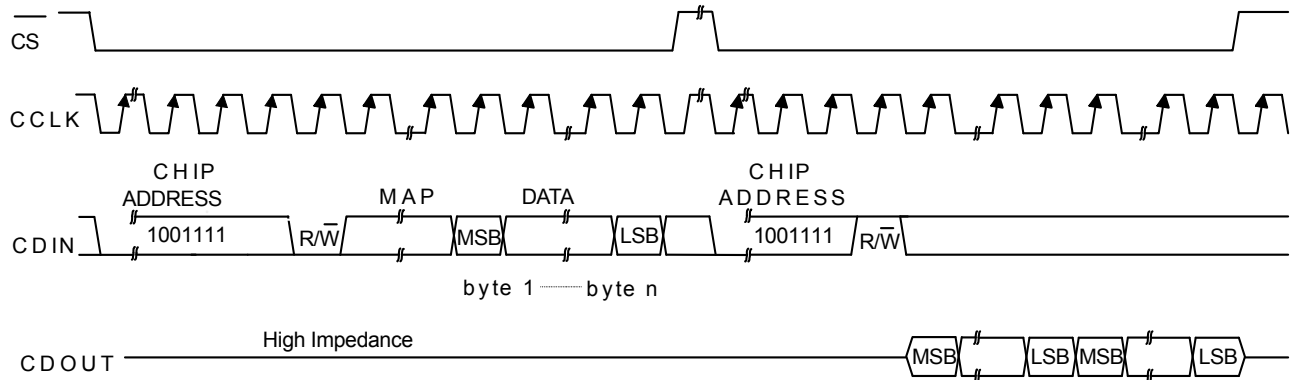

MAP = Memory Address Pointer, 8 bits, MSB first

Figure 17. Control Port Timing in SPI Mode

4.12.2 I²C Mode

In I²C Mode, \overline{SDA} is a bidirectional data line. Data is clocked into and out of the part by the clock, SCL. There is no \overline{CS} pin. Pins AD0 and AD1 form the two least-significant bits of the chip address and should be connected through a resistor to VLC or DGND as desired. The state of the pins is sensed while the CS4245 is being reset.

The signal timings for a read and write cycle are shown in Figure 18 and Figure 19. A Start condition is defined as a falling transition of \overline{SDA} while the clock is high. A Stop condition is a rising transition while the clock is high. All other transitions of \overline{SDA} occur while the clock is low. The first byte sent to the CS4245 after a Start condition consists of a 7-bit chip address field and a R/W bit (high for a read, low for a write). The upper 5 bits of the 7-bit address field are fixed at 10011. To communicate with a CS4245, the chip address field, which is the first byte sent to the CS4245, should match 10011 followed by the settings of the AD1 and AD0. The eighth bit of the address is the R/W bit. If the operation is a write, the next byte is the Memory Address Pointer (MAP) which selects the register to be read or written. If the operation is a read, the contents of the register pointed to by the MAP will be output. Following each data byte, the memory address pointer will automatically increment to facilitate block reads and writes of successive registers. Each byte is separated by an acknowledge bit. The ACK bit is output from the CS4245 after each input byte is read, and is input to the CS4245 from the microcontroller after each transmitted byte.

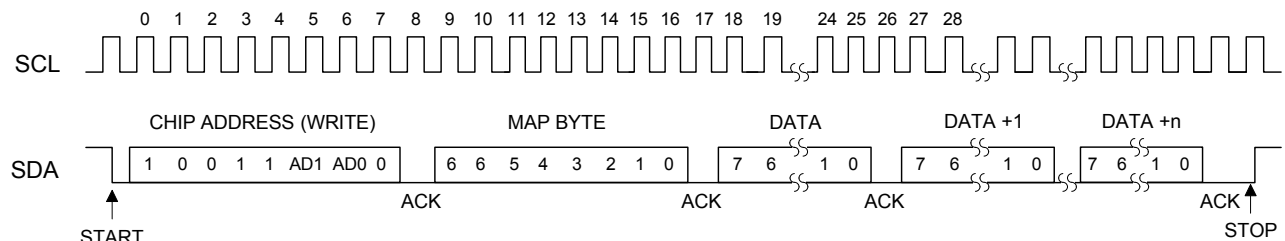

Figure 18. Control Port Timing, I²C Write

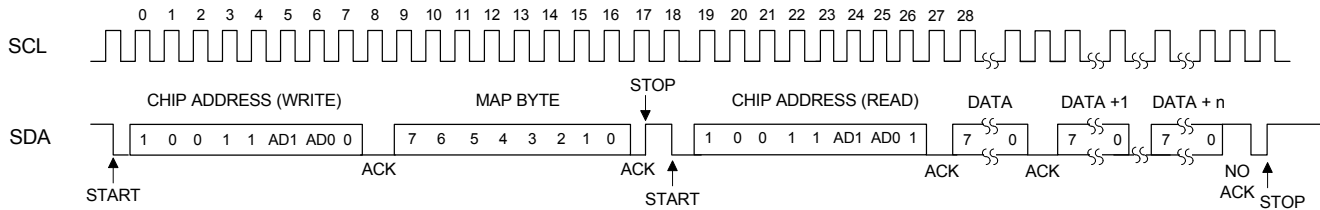

Figure 19. Control Port Timing, I²C Read

Since the read operation cannot set the MAP, an aborted write operation is used as a preamble. As shown in [Figure 19](#), the write operation is aborted after the acknowledge for the MAP byte by sending a stop condition. The following pseudocode illustrates an aborted write operation followed by a read operation.

- Send start condition.
- Send 10011xx0 (chip address & write operation).
- Receive acknowledge bit.
- Send MAP byte.
- Receive acknowledge bit.
- Send stop condition, aborting write.
- Send start condition.
- Send 10011xx1 (chip address & read operation).
- Receive acknowledge bit.
- Receive byte, contents of selected register.
- Send acknowledge bit.
- Send stop condition.

4.13 Interrupts and Overflow

The CS4245 has a comprehensive interrupt capability. The INT output pin is intended to drive the interrupt input pin on the host microcontroller. The INT pin may function as either an active high CMOS driver or an active low open-drain driver (see [“Active High/Low \(Bit 0\)”](#) on page 50). When configured as active low open-drain, the INT pin has no active pull-up transistor, allowing it to be used for wired-OR hook-ups with multiple peripherals connected to the microcontroller interrupt input pin. In this configuration, an external pull-up resistor must be placed on the INT pin for proper operation.

Many conditions can cause an interrupt, as listed in the interrupt status register descriptions (see [“Interrupt Status - Address 0Dh”](#) on page 50). Each source may be masked off through mask register bits. In addition, each source may be set to rising edge, falling edge, or level-sensitive. Combined with the option of level-sensitive or edge-sensitive modes within the microcontroller, many different configurations are possible, depending on the needs of the equipment designer.

The CS4245 also has a dedicated overflow output. The OVFL pin functions as active low open drain and has no active pull-up transistor, thereby requiring an external pull-up resistor. The OVFL pin outputs an OR of the ADCOverflow and ADCUnderflow conditions available in the Interrupt Status register; however, these conditions do not need to be unmasked for proper operation of the OVFL pin.

4.14 Reset

When $\overline{\text{RESET}}$ is low, the CS4245 enters a low-power mode and all internal states are reset, including the control port and registers, the outputs are muted. When $\overline{\text{RESET}}$ is high, the control port becomes operational, and the desired settings should be loaded into the control registers. Writing a 0 to the PDN bit in the Power Control register will then cause the part to leave the low-power state and begin operation.

The delta-sigma modulators settle in a matter of microseconds after the analog section is powered, either through the application of power or by setting the $\overline{\text{RESET}}$ pin high. However, the voltage reference will take much longer to reach a final value due to the presence of external capacitance on the FILT1+ and FILT2+ pins. During this voltage reference ramp delay, both SDOOUT and DAC outputs will be automatically muted.

It is recommended that $\overline{\text{RESET}}$ be activated if the analog or digital supplies drop below the recommended operating condition to prevent power-glitch-related issues.

4.15 Synchronization of Multiple Devices

In systems where multiple ADCs are required, care must be taken to achieve simultaneous sampling. To ensure synchronous sampling, the master clocks and left/ right clocks must be the same for all of the CS4245s in the system. If only one master clock source is needed, one solution is to place one CS4245 in Master Mode, and slave all of the other CS4245s to the one master. If multiple master clock sources are needed, a possible solution would be to supply all clocks from the same external source and time the CS4245 reset with the inactive edge of master clock. This will ensure that all converters begin sampling on the same clock edge.

4.16 Grounding and Power Supply Decoupling

As with any high-resolution converter, the CS4245 requires careful attention to power supply and grounding arrangements if its potential performance is to be realized. Figure 12 shows the recommended power arrangements, with VA connected to a clean supply. VD, which powers the digital filter, may be run from the system logic supply (VLS or VLC) or may be powered from the analog supply (VA) via a resistor. In this case, no additional devices should be powered from VD. Power supply decoupling capacitors should be as near to the CS4245 as possible, with the low value ceramic capacitor being the nearest. All signals, especially clocks, should be kept away from the FILT1+, FILT2+, VQ1 and VQ2 pins in order to avoid unwanted coupling into the modulators. The FILT1+, FILT2+, VQ1 and VQ2 decoupling capacitors, particularly the 0.1 μF , must be positioned to minimize the electrical path from FILT1+ and FILT2+ and AGND. The CS4245 evaluation board demonstrates the optimum layout and power supply arrangements. To minimize digital noise, connect the CS4245 digital outputs only to CMOS inputs.

5. REGISTER QUICK REFERENCE

This table shows the register names and their associated default values.

Addr	Function	7	6	5	4	3	2	1	0
01h	Chip ID	PART3	PART2	PART1	PART0	REV3	REV2	REV1	REV0
		1	1	0	0	0	0	0	1
02h	Power Control	Freeze	Reserved	Reserved	Reserved	PDN_MIC	PDN_ADC	PDN_DAC	PDN
		0	0	0	0	0	0	0	1
03h	DAC Control 1	DAC_FM1	DAC_FM0	DAC_DIF1	DAC_DIF0	Reserved	MuteDAC	DeEmph	DAC_M/S
		0	0	0	0	1	0	0	0
04h	ADC Control	ADC_FM1	ADC_FM0	Reserved	ADC_DIF	Reserved	MuteADC	HPFFreeze	ADC_M/S
		0	0	0	0	0	0	0	0
05h	MCLK Frequency	Reserved	MCLK1 Freq2	MCLK1 Freq1	MCLK1 Freq0	Reserved	MCLK2 Freq2	MCLK2 Freq1	MCLK2 Freq0
		0	0	0	0	0	0	0	0
06h	Signal Selection	Reserved	AOutSel1	AOutSel0	Reserved	Reserved	Reserved	LOOP	ASynch
		0	1	0	0	0	0	0	0
07h	PGA Ch B Gain Control	Reserved	Reserved	Gain5	Gain4	Gain3	Gain2	Gain1	Gain0
		0	0	0	0	0	0	0	0
08h	PGA Ch A Gain Control	Reserved	Reserved	Gain5	Gain4	Gain3	Gain2	Gain1	Gain0
		0	0	0	0	0	0	0	0
09h	Analog Input Control	Reserved	Reserved	Reserved	PGASoft	PGAZero	Sel2	Sel1	Sel0
		0	0	0	1	1	0	0	1
0Ah	DAC Ch A Volume Control	Vol7	Vol6	Vol5	Vol4	Vol3	Vol2	Vol1	Vol0
		0	0	0	0	0	0	0	0
0Bh	DAC Ch B Volume Control	Vol7	Vol6	Vol5	Vol4	Vol3	Vol2	Vol1	Vol0
		0	0	0	0	0	0	0	0
0Ch	DAC Control 2	DACSoft	DACZero	InvertDAC	Reserved	Reserved	Reserved	Reserved	Active_H/L
		1	1	0	0	0	0	0	0
0Dh	Interrupt Status	Reserved	Reserved	Reserved	Reserved	ADCCIkErr	DACCkErr	ADCOvfI	ADCUndrfI
		0	0	0	0	0	0	0	0
0Eh	Interrupt Mask	Reserved	Reserved	Reserved	Reserved	ADCCIkErrM	DACCkErrM	ADCOvfIM	ADCUndrfIM
		0	0	0	0	0	0	0	0
0Fh	Interrupt Mode MSB	Reserved	Reserved	Reserved	Reserved	ADCCIkErr1	DACCkErr1	ADCOvfI1	ADCUndrfI1
		0	0	0	0	0	0	0	0
10h	Interrupt Mode LSB	Reserved	Reserved	Reserved	Reserved	ADCCIkErr0	DACCkErr0	ADCOvfI0	ADCUndrfI0
		0	0	0	0	0	0	0	0

6. REGISTER DESCRIPTION

6.1 Chip ID - Register 01h

7	6	5	4	3	2	1	0
PART3	PART2	PART1	PART0	REV3	REV2	REV1	REV0

Function:

This register is Read-Only. Bits 7 through 4 are the part number ID, which is 1100b (0Ch), and the remaining bits (3 through 0) indicate the device revision as shown in [Table 5](#) below.

REV[2:0]	Revision
001	A
010	B, C0
011	C1

Table 5. Device Revision

6.2 Power Control - Address 02h

7	6	5	4	3	2	1	0
Freeze	Reserved	Reserved	Reserved	PDN_MIC	PDN_ADC	PDN_DAC	PDN

6.2.1 Freeze (Bit 7)

Function:

This function allows modifications to be made to certain control port bits without the changes taking effect until the Freeze bit is disabled. To make multiple changes to these bits take effect simultaneously, set the Freeze bit, make all changes, then clear the Freeze bit. The bits affected by the Freeze function are listed in [Table 6](#).

Name	Register	Bit(s)
MuteDAC	03h	2
MuteADC	04h	2
Gain[5:0]	07h	5:0
Gain[5:0]	08h	5:0
Vol[7:0]	0Ah	7:0
Vol[7:0]	0Bh	7:0

Table 6. Freeze-able Bits

6.2.2 Power-Down MIC (Bit 3)

Function:

The microphone preamplifier block will enter a low-power state whenever this bit is set.

6.2.3 Power-Down ADC (Bit 2)

Function:

The ADC pair will remain in a reset state whenever this bit is set.

6.2.4 Power-Down DAC (Bit 1)

Function:

The DAC pair will remain in a reset state whenever this bit is set.

6.2.5 Power-Down Device (Bit 0)

Function:

The device will enter a low-power state whenever this bit is set. The power-down bit is set by default and must be cleared before normal operation can occur. The contents of the control registers are retained when the device is in power-down.

6.3 DAC Control - Address 03h

7	6	5	4	3	2	1	0
DAC_FM1	DAC_FM0	DAC_DIF1	DAC_DIF0	Reserved	MuteDAC	DeEmph	DAC_M \bar{S}

6.3.1 DAC Functional Mode (Bits 7:6)

Function:

Selects the required range of input sample rates.

DAC_FM1	DAC_FM0	Mode
0	0	Single-Speed Mode: 4 to 50 kHz sample rates
0	1	Double-Speed Mode: 50 to 100 kHz sample rates
1	0	Quad-Speed Mode: 100 to 200 kHz sample rates
1	1	Reserved

Table 7. Functional Mode Selection

6.3.2 DAC Digital Interface Format (Bits 5:4)

Function:

The required relationship between LRCK, SCLK and SDIN for the DAC is defined by the DAC Digital Interface Format and the options are detailed in [Table 8](#) and [Figures 7-9](#).

DAC_DIF1	DAC_DIF0	Description	Format	Figure
0	0	Left Justified, up to 24-bit data (default)	0	7
0	1	I ² S, up to 24-bit data	1	8
1	0	Right-Justified, 16-bit Data	2	9
1	1	Right-Justified, 24-bit Data	3	9

Table 8. DAC Digital Interface Formats

6.3.3 Mute DAC (Bit 2)

Function:

The DAC outputs will mute and the $\overline{\text{MUTE C}}$ pin will become active when this bit is set. Though this bit is active high, it should be noted that the $\overline{\text{MUTE C}}$ pin is active low. The common mode voltage on the outputs will be retained when this bit is set. The muting function is effected, similar to attenuation changes, by the DACSoft and DACZero bits in the DAC Control 2 register.

6.3.4 De-Emphasis Control (Bit 1)

Function:

The standard 50/15 μ s digital de-emphasis filter response, [Figure 20](#), may be implemented for a sample rate of 44.1 kHz when the DeEmph bit is configured as shown in [Table 9](#). NOTE: De-emphasis is available only in Single-Speed Mode.

DeEmph	Description
0	Disabled (default)
1	44.1 kHz de-emphasis

Table 9. De-Emphasis Control

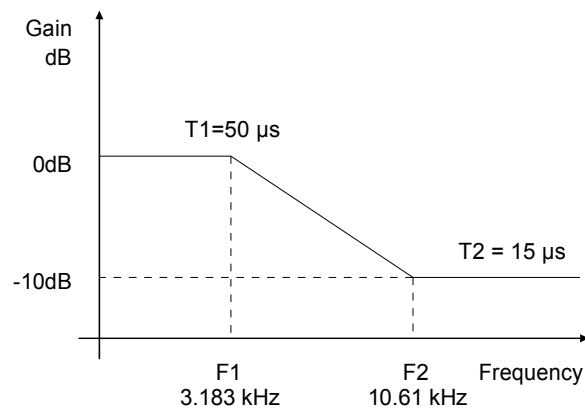

Figure 20. De-Emphasis Curve

6.3.5 DAC Master / Slave Mode (Bit 0)

Function:

This bit selects either master or slave operation for serial audio port 2. Setting this bit will select Master Mode, while clearing this bit will select Slave Mode.

6.4 ADC Control - Address 04h

7	6	5	4	3	2	1	0
ADC_FM1	ADC_FM0	Reserved	ADC_DIF	Reserved	MuteADC	HPFFreeze	ADC_M \bar{S}

6.4.1 ADC Functional Mode (Bits 7:6)

Function:

Selects the required range of output sample rates.

ADC_FM1	ADC_FM0	Mode
0	0	Single-Speed Mode: 4 to 50 kHz sample rates
0	1	Double-Speed Mode: 50 to 100 kHz sample rates
1	0	Quad-Speed Mode: 100 to 200 kHz sample rates
1	1	Reserved

Table 10. Functional Mode Selection

6.4.2 ADC Digital Interface Format (Bit 4)

Function:

The required relationship between LRCK1, SCLK1 and SDOUT is defined by the ADC Digital Interface Format bit. The options are detailed in [Table 11](#) and may be seen in [Figure 7](#) and [Figure 8](#).

ADC_DIF	Description	Format	Figure
0	Left-Justified, up to 24-bit data (default)	0	7
1	I ² S, up to 24-bit data	1	8

Table 11. ADC Digital Interface Formats

6.4.3 Mute ADC (Bit 2)

Function:

When this bit is set, the serial audio output of the both ADC channels is muted.

6.4.4 ADC High-Pass Filter Freeze (Bit 1)

Function:

When this bit is set, the internal high-pass filter is disabled. The current DC offset value will be frozen and continue to be subtracted from the conversion result. See [“High-Pass Filter and DC Offset Calibration” on page 32](#).

6.4.5 ADC Master / Slave Mode (Bit 0)

Function:

This bit selects either master or slave operation for serial audio port 1. Setting this bit selects Master Mode, while clearing this bit selects Slave Mode.

6.5 MCLK Frequency - Address 05h

7	6	5	4	3	2	1	0
Reserved	MCLK1 Freq2	MCLK1 Freq1	MCLK1 Freq0	Reserved	MCLK2 Freq2	MCLK2 Freq1	MCLK2 Freq0

6.5.1 Master Clock 1 Frequency (Bits 6:4)

Function:

Sets the frequency of the supplied MCLK1 signal. See [Table 12](#) for the appropriate settings.

MCLK1 Divider	MCLK1 Freq2	MCLK1 Freq1	MCLK1 Freq0
÷ 1	0	0	0
÷ 1.5	0	0	1
÷ 2	0	1	0
÷ 3	0	1	1
÷ 4	1	0	0
Reserved	1	0	1
Reserved	1	1	x

Table 12. MCLK 1 Frequency

6.5.2 Master Clock 2 Frequency (Bits 2:0)

Function:

These bits set the frequency of the supplied MCLK2 signal. See [Table 13](#) for the appropriate settings.

MCLK2 Divider	MCLK2 Freq2	MCLK2 Freq1	MCLK2 Freq0
÷ 1	0	0	0
÷ 1.5	0	0	1
÷ 2	0	1	0
÷ 3	0	1	1
÷ 4	1	0	0
Reserved	1	0	1
Reserved	1	1	x

Table 13. MCLK 2 Frequency

6.6 Signal Selection - Address 06h

7	6	5	4	3	2	1	0
Reserved	AOutSel1	AOutSel0	Reserved	Reserved	Reserved	LOOP	ASynch

6.6.1 Auxiliary Output Source Select (Bits 6:5)

Function:

These bits are used to select the analog output source. Please refer to [Table 14](#).

AOutSel1	AOutSel0	Auxiliary Output Source
0	0	High Impedance
0	1	DAC Output
1	0	PGA Output
1	1	Reserved

Table 14. Auxiliary Output Source Selection

6.6.2 Digital Loopback (Bit 1)

Function:

When this bit is set, an internal digital loopback from the ADC to the DAC are enabled. Please refer to [“Internal Digital Loopback” on page 36](#).

6.6.3 Asynchronous Mode (Bit 0)

Function:

When this bit is set, the DAC and ADC may be operated at independent asynchronous sample rates derived from MCLK1 and MCLK2. When this bit is cleared, the DAC and ADC must operate at synchronous sample rates derived from MCLK1.

6.7 Channel B PGA Control - Address 07h

7	6	5	4	3	2	1	0
Reserved	Reserved	Gain5	Gain4	Gain3	Gain2	Gain1	Gain0

6.7.1 Channel B PGA Gain (Bits 5:0)

Function:

See “Channel A PGA Gain (Bits 5:0)” on page 47.

6.8 Channel A PGA Control - Address 08h

7	6	5	4	3	2	1	0
Reserved	Reserved	Gain5	Gain4	Gain3	Gain2	Gain1	Gain0

6.8.1 Channel A PGA Gain (Bits 5:0)

Function:

Sets the gain or attenuation for the ADC input PGA stage. The gain may be adjusted from -12 dB to +12 dB in 0.5 dB steps. The gain bits are in two’s complement with the Gain0 bit set for a 0.5 dB step. Register settings outside of the ± 12 dB range are reserved and must not be used. See [Table 15](#) for example settings.

Gain[5:0]	Setting
101000	-12 dB
000000	0 dB
011000	+12 dB

Table 15. Example Gain and Attenuation Settings

6.9 ADC Input Control - Address 09h

7	6	5	4	3	2	1	0
Reserved	Reserved	Reserved	PGAsoft	PGAZero	Sel2	Sel1	Sel0

6.9.1 PGA Soft Ramp or Zero Cross Enable (Bits 4:3)

Function:

Soft Ramp Enable

Soft Ramp allows level changes, both muting and attenuation, to be implemented by incrementally ramping, in 1/8 dB steps, from the current level to the new level at a rate of 1 dB per 8 left/right clock periods. See [Table 16](#).

Zero Cross Enable

Zero Cross Enable dictates that signal-level changes, either by attenuation changes or muting, will occur on a signal zero crossing to minimize audible artifacts. The requested level change will occur after a time-out period between 512 and 1024 sample periods (10.7 ms to 21.3 ms at 48 kHz sample rate) if the signal does not encounter a zero crossing. The zero cross function is independently monitored and implemented for each channel. See [Table 16](#).

Soft Ramp and Zero Cross Enable

Soft Ramp and Zero Cross Enable dictate that signal-level changes, either by attenuation changes or muting, will occur in 1/8 dB steps and be implemented on a signal zero crossing. The 1/8 dB level change will

occur after a time-out period between 512 and 1024 sample periods (10.7 ms to 21.3 ms at 48 kHz sample rate) if the signal does not encounter a zero crossing. The zero cross function is independently monitored and implemented for each channel. See [Table 16](#).

PGASoft	PGAZeroCross	Mode
0	0	Changes to affect immediately
0	1	Zero Cross enabled
1	0	Soft Ramp enabled
1	1	Soft Ramp and Zero Cross enabled (default)

Table 16. PGA Soft Cross or Zero Cross Mode Selection

6.9.2 Analog Input Selection (Bits 2:0)

Function:

These bits are used to select the input source for the PGA and ADC. Please see [Table 17](#).

Sel2	Sel1	Sel0	PGA/ADC Input
0	0	0	Microphone-Level Inputs (+32 dB Gain Enabled)
0	0	1	Line-Level Input Pair 1
0	1	0	Line-Level Input Pair 2
0	1	1	Line-Level Input Pair 3
1	0	0	Line-Level Input Pair 4
1	0	1	Line-Level Input Pair 5
1	1	0	Line-Level Input Pair 6
1	1	1	Reserved

Table 17. Analog Input Multiplexer Selection

6.10 DAC Channel A Volume Control - Address 0Ah

See [6.11 DAC Channel B Volume Control - Address 0Bh](#).

6.11 DAC Channel B Volume Control - Address 0Bh

7	6	5	4	3	2	1	0
Vol7	Vol6	Vol5	Vol4	Vol3	Vol2	Vol1	Vol0

6.11.1 Volume Control (Bits 7:0)

Function:

The digital volume control allows the user to attenuate the signal in 0.5 dB increments from 0 to -127 dB. The Vol0 bit activates a 0.5 dB attenuation when set, and no attenuation when cleared. The Vol[7:1] bits activate attenuation equal to their decimal equivalent (in dB). Example volume settings are decoded as

shown in [Table 18](#). The volume changes are implemented as dictated by the DACSoft and DACZero-Cross bits in the DAC Control 2 register (see [Section 6.12.1](#)).

Binary Code	Volume Setting
00000000	0 dB
00000001	-0.5 dB
00101000	-20 dB
00101001	-20.5 dB
11111110	-127 dB
11111111	-127.5 dB

Table 18. Digital Volume Control Example Settings

6.12 DAC Control 2 - Address 0Ch

7	6	5	4	3	2	1	0
DACSoft	DACZero	InvertDAC	Reserved	Reserved	Reserved	Reserved	Active_H/L

6.12.1 DAC Soft Ramp or Zero Cross Enable (Bits 7:6)

Function:

Soft Ramp Enable

Soft Ramp allows level changes, both muting and attenuation, to be implemented by incrementally ramping, in 1/8 dB steps, from the current level to the new level at a rate of 1 dB per 8 left/right clock periods. See [Table 19](#).

Zero Cross Enable

Zero Cross Enable dictates that signal-level changes, either by attenuation changes or muting, will occur on a signal zero crossing to minimize audible artifacts. The requested level change will occur after a time-out period between 512 and 1024 sample periods (10.7 ms to 21.3 ms at 48 kHz sample rate) if the signal does not encounter a zero crossing. The zero cross function is independently monitored and implemented for each channel. See [Table 19](#).

Soft Ramp and Zero Cross Enable

Soft Ramp and Zero Cross Enable dictate that signal-level changes, either by attenuation changes or muting, will occur in 1/8 dB steps and be implemented on a signal zero crossing. The 1/8 dB level change will occur after a time-out period between 512 and 1024 sample periods (10.7 ms to 21.3 ms at 48 kHz sample rate) if the signal does not encounter a zero crossing. The zero cross function is independently monitored and implemented for each channel. See [Table 19](#).

DACSoft	DACZeroCross	Mode
0	0	Changes to affect immediately
0	1	Zero Cross enabled
1	0	Soft Ramp enabled
1	1	Soft Ramp and Zero Cross enabled (default)

Table 19. DAC Soft Cross or Zero Cross Mode Selection

6.12.2 Invert DAC Output (Bit 5)

Function:

When this bit is set, the output of the DAC is inverted.

6.12.3 Active High/Low (Bit 0)

Function:

When this bit is set, the INT pin functions as an active high CMOS driver.

When this bit is cleared, the INT pin functions as an active low open drain driver and will require an external pull-up resistor for proper operation.

6.13 Interrupt Status - Address 0Dh

7	6	5	4	3	2	1	0
Reserved	Reserved	Reserved	Reserved	ADCClkErr	DACCkErr	ADCOvfl	ADCUndrfl

For all bits in this register, a '1' means the associated interrupt condition has occurred at least once since the register was last read. A '0' means the associated interrupt condition has NOT occurred since the last reading of the register. Status bits that are masked off in the associated mask register will always be '0' in this register. This register defaults to 00h.

6.13.1 ADC Clock Error (Bit 3)

Function:

Indicates the occurrence of an ADC clock error condition.

6.13.2 DAC Clock Error (Bit 2)

Function:

Indicates the occurrence of a DAC clock error condition.

6.13.3 ADC Overflow (Bit 1)

Function:

Indicates the occurrence of an ADC overflow condition.

6.13.4 ADC Underflow (Bit 0)

Function:

Indicates the occurrence of an ADC underflow condition.

6.14 Interrupt Mask - Address 0Eh

7	6	5	4	3	2	1	0
Reserved	Reserved	Reserved	Reserved	ADCCkErrM	DACCkErrM	ADCOvflM	ADCUndrflM

Function:

The bits of this register serve as a mask for the Status sources found in the register [“Interrupt Status - Address 0Dh” on page 50](#). If a mask bit is set to 1, the error is unmasked, meaning that its occurrence will affect the INT pin and the status register. If a mask bit is set to 0, the error is masked, meaning that its occurrence will not affect the INT pin or the status register. The bit positions align with the corresponding bits in the Status register.

6.15 Interrupt Mode MSB - Address 0Fh
6.16 Interrupt Mode LSB - Address 10h

7	6	5	4	3	2	1	0
Reserved	Reserved	Reserved	Reserved	ADCCIkErr1	DACCIkErr1	ADCOvf1	ADCUndrf1
Reserved	Reserved	Reserved	Reserved	ADCCIkErr0	DACCIkErr0	ADCOvf0	ADCUndrf0

Function:

The two Interrupt Mode registers form a 2-bit code for each Interrupt Status register function. There are three ways to set the INT pin active in accordance with the interrupt condition. In the Rising-Edge Active Mode, the INT pin becomes active on the arrival of the interrupt condition. In the Falling-Edge Active Mode, the INT pin becomes active on the removal of the interrupt condition. In Level-Active Mode, the INT pin remains active during the interrupt condition.

- 00 - Rising edge active
- 01 - Falling edge active
- 10 - Level active
- 11 - Reserved

7. PARAMETER DEFINITIONS

Dynamic Range

The ratio of the rms value of the signal to the rms sum of all other spectral components over the specified bandwidth. Dynamic Range is a signal-to-noise ratio measurement over the specified bandwidth made with a -60 dBFS signal. 60 dB is added to resulting measurement to refer the measurement to full scale. This technique ensures that the distortion components are below the noise level and do not affect the measurement. This measurement technique has been accepted by the Audio Engineering Society, AES17-1991, and the Electronic Industries Association of Japan, EIAJ CP-307. Expressed in decibels.

Total Harmonic Distortion + Noise

The ratio of the rms value of the signal to the rms sum of all other spectral components over the specified bandwidth (typically 10 Hz to 20 kHz), including distortion components. Expressed in decibels. Measured at -1 and -20 dBFS as suggested in AES17-1991 Annex A.

Frequency Response

A measure of the amplitude response variation from 10 Hz to 20 kHz relative to the amplitude response at 1 kHz. Units in decibels.

Interchannel Isolation

A measure of crosstalk between the left and right channels. Measured for each channel at the converter's output with no signal to the input under test and a full-scale signal applied to the other channel. Units in decibels.

Interchannel Gain Mismatch

The gain difference between left and right channels. Units in decibels.

Gain Drift

The change in gain value with temperature. Units in ppm/°C.

8. DAC FILTER PLOTS

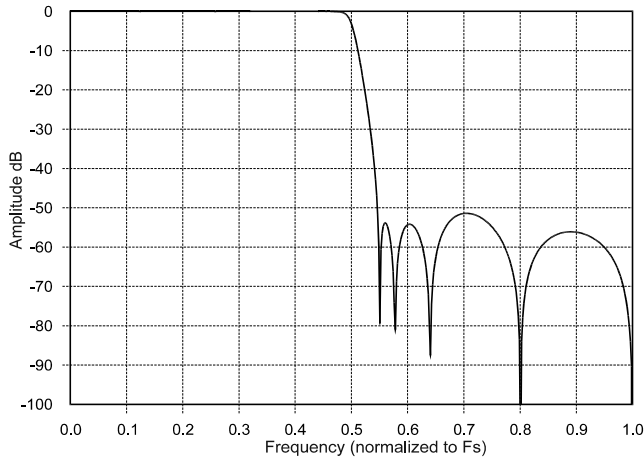

Figure 21. DAC Single-Speed Stopband Rejection

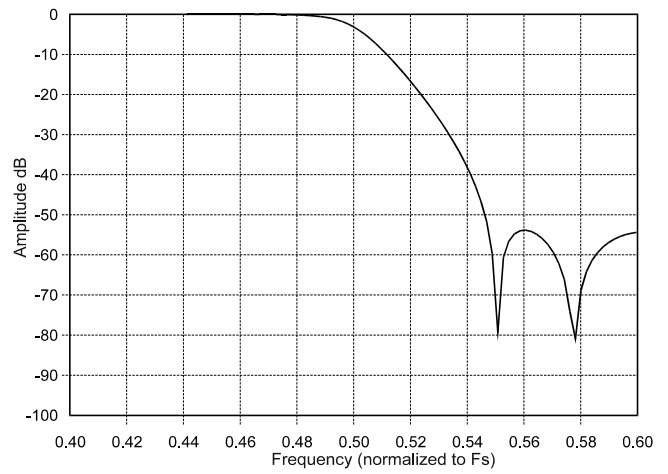

Figure 22. DAC Single-Speed Transition Band

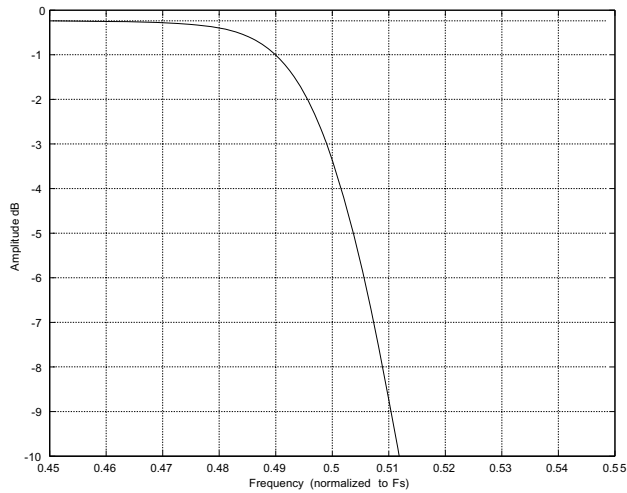

Figure 23. DAC Single-Speed Transition Band

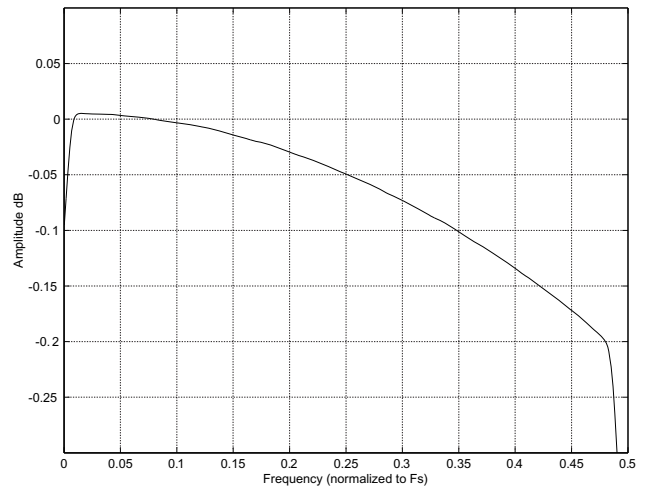

Figure 24. DAC Single-Speed Passband Ripple

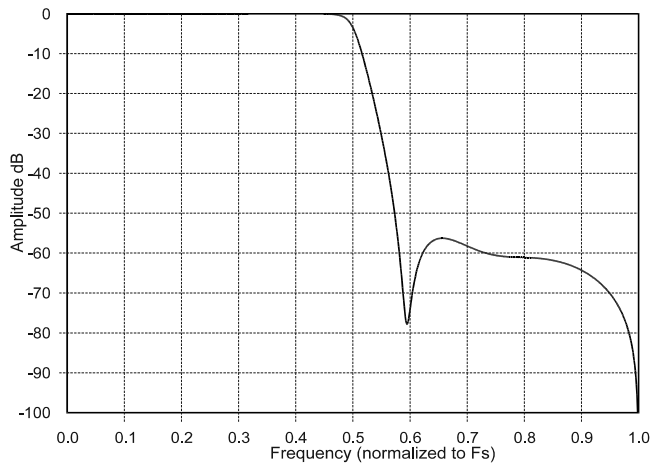

Figure 25. DAC Double-Speed Stopband Rejection

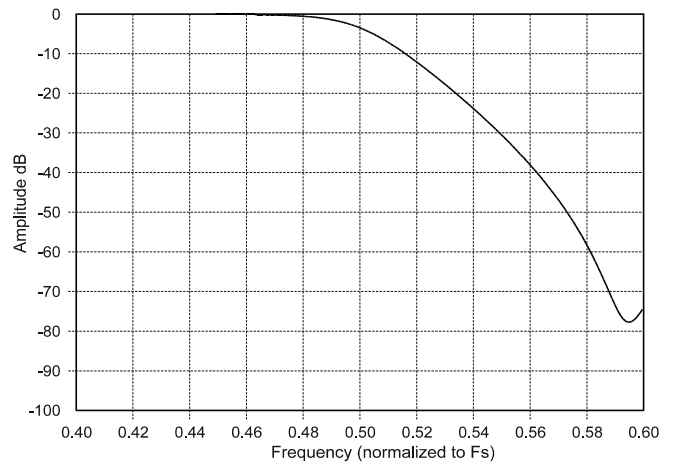

Figure 26. DAC Double-Speed Transition Band

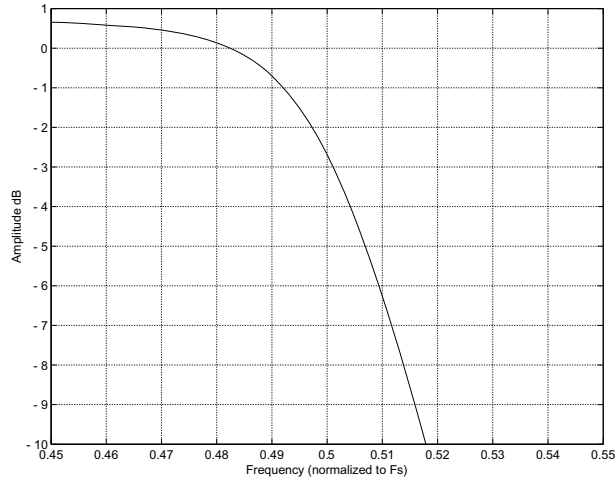

Figure 27. DAC Double-Speed Transition Band

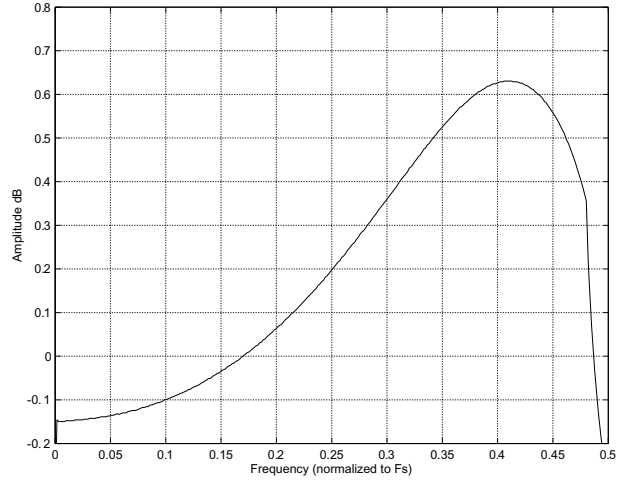

Figure 28. DAC Double-Speed Passband Ripple

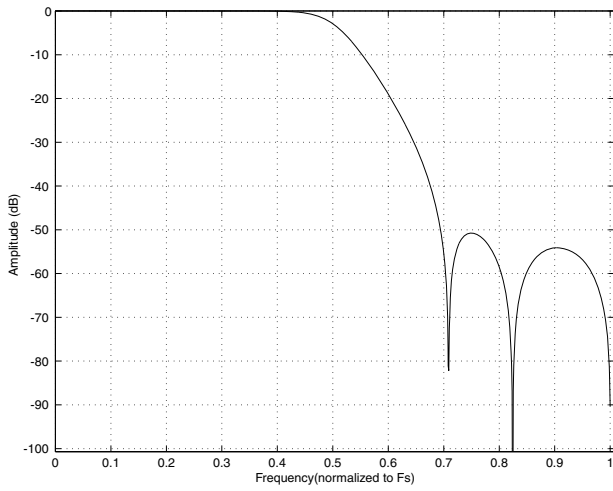

Figure 29. DAC Quad-Speed Stopband Rejection

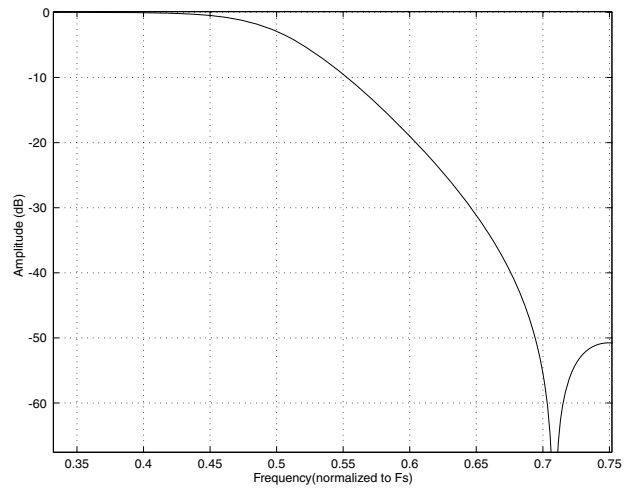

Figure 30. DAC Quad-Speed Transition Band

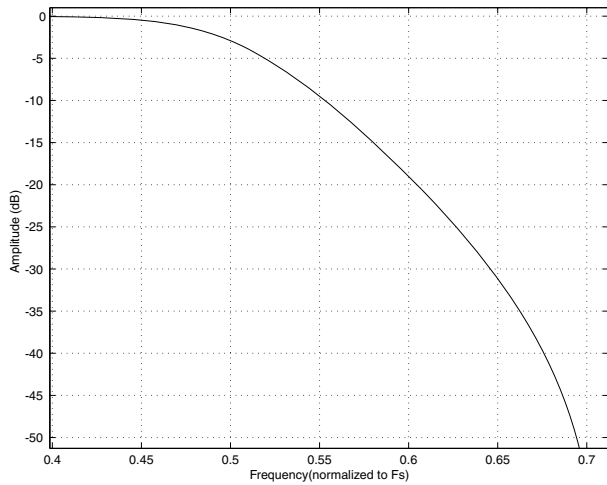

Figure 31. DAC Quad-Speed Transition Band

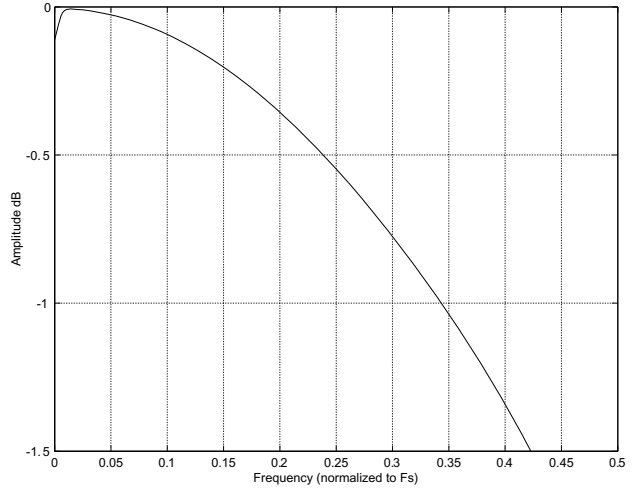

Figure 32. DAC Quad-Speed Passband Ripple

9. ADC FILTER PLOTS

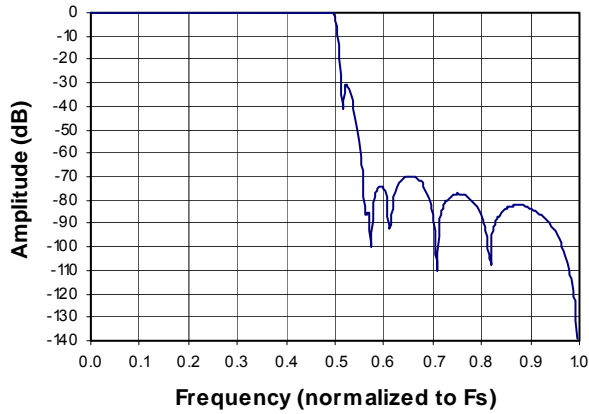

Figure 33. ADC Single-Speed Stopband Rejection

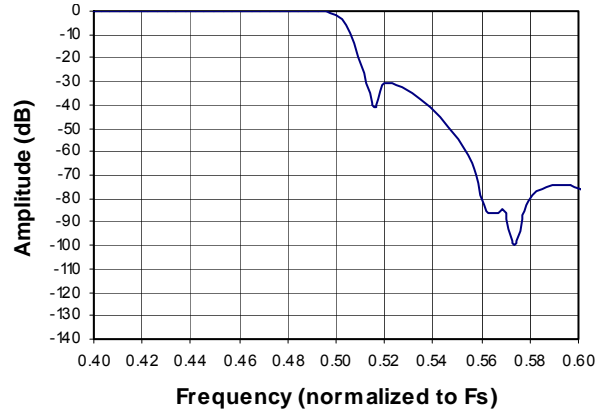

Figure 34. ADC Single-Speed Stopband Rejection

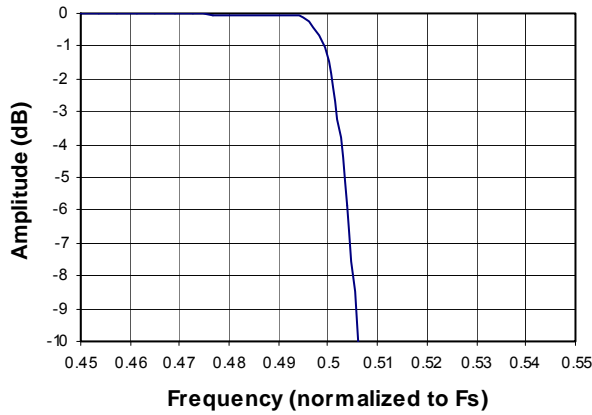

Figure 35. ADC Single-Speed Transition Band (Detail)

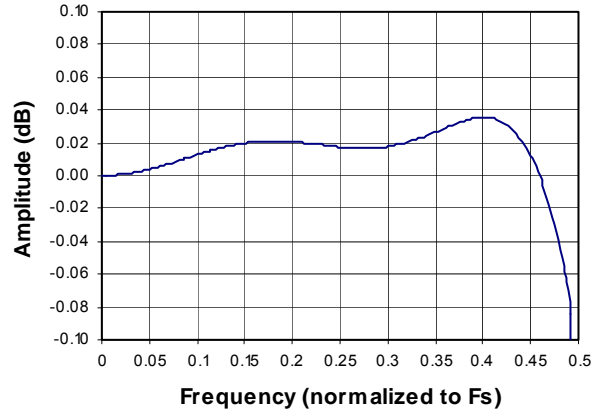

Figure 36. ADC Single-Speed Passband Ripple

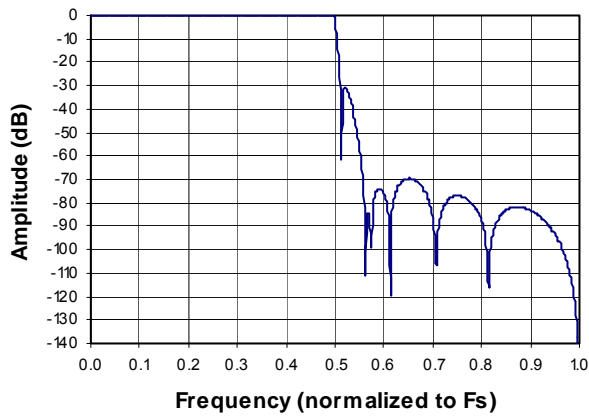

Figure 37. ADC Double-Speed Stopband Rejection

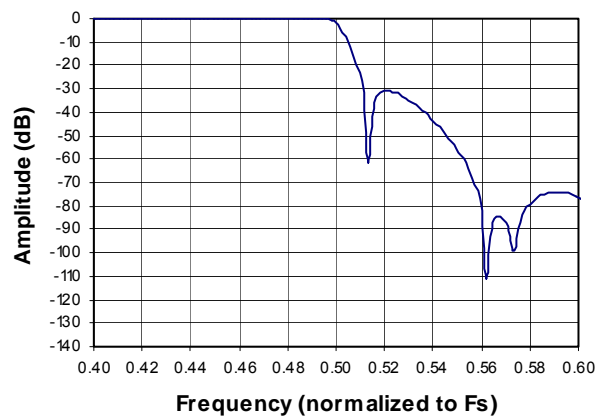

Figure 38. ADC Double-Speed Stopband Rejection

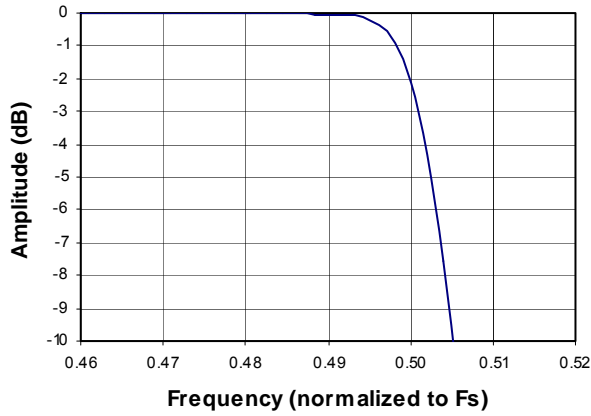

Figure 39. ADC Double-Speed Transition Band (Detail)

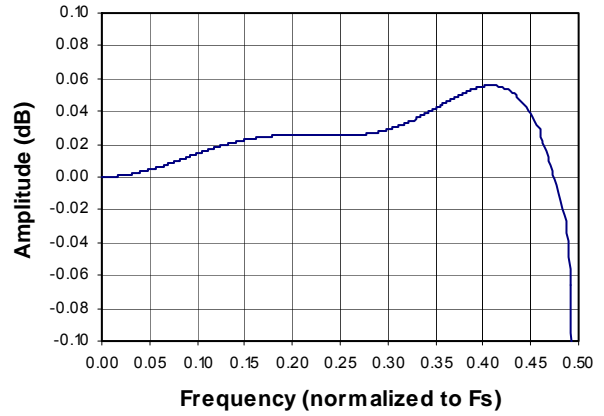

Figure 40. ADC Double-Speed Passband Ripple

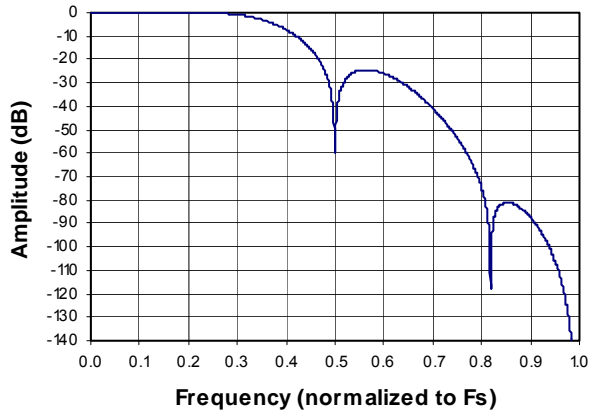

Figure 41. ADC Quad-Speed Stopband Rejection

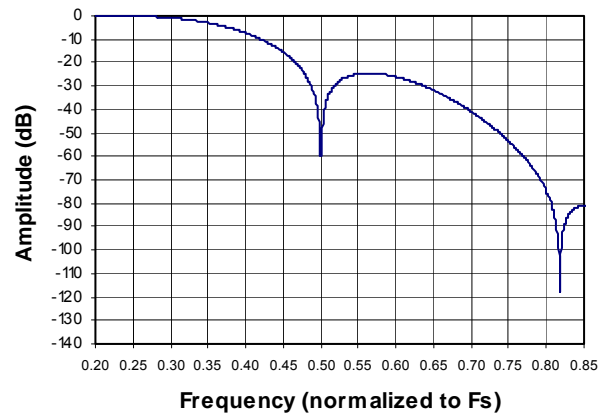

Figure 42. ADC Quad-Speed Stopband Rejection

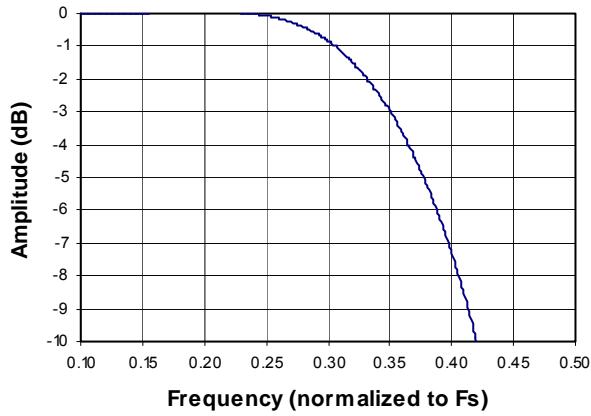

Figure 43. ADC Quad-Speed Transition Band (Detail)

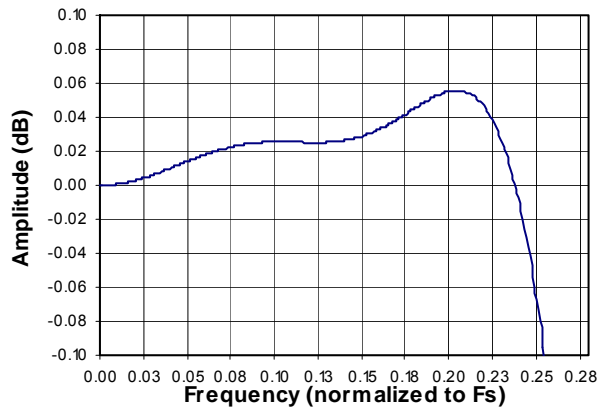
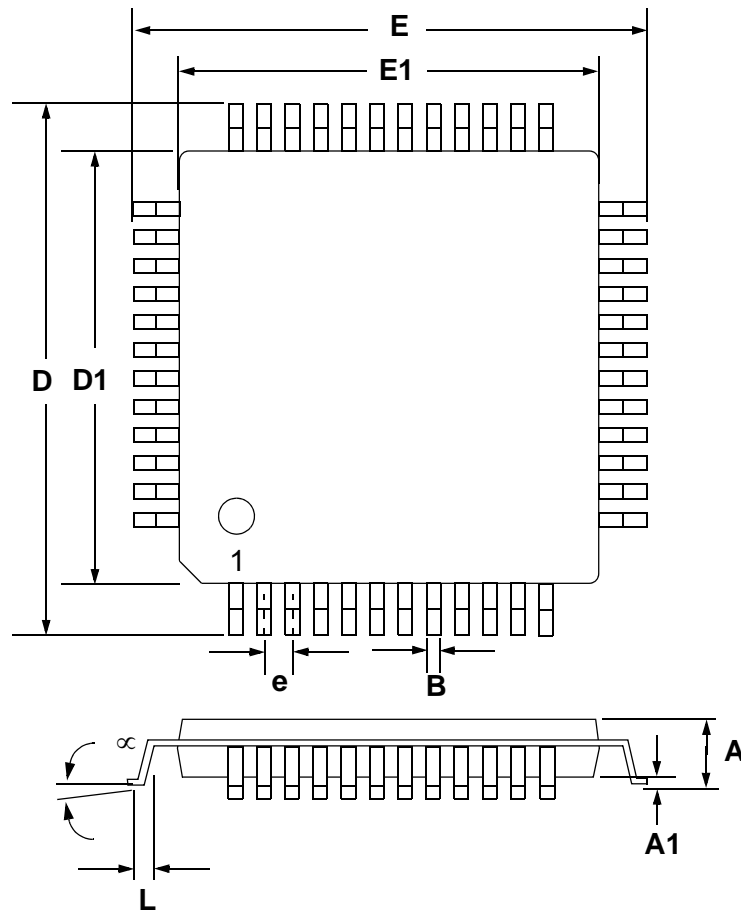

Figure 44. ADC Quad-Speed Passband Ripple

10. PACKAGE DIMENSIONS
48L LQFP PACKAGE DRAWING

DIM	INCHES			MILLIMETERS		
	MIN	NOM	MAX	MIN	NOM	MAX
A	---	0.055	0.063	---	1.40	1.60
A1	0.002	0.004	0.006	0.05	0.10	0.15
B	0.007	0.009	0.011	0.17	0.22	0.27
D	0.343	0.354	0.366	8.70	9.0 BSC	9.30
D1	0.272	0.28	0.280	6.90	7.0 BSC	7.10
E	0.343	0.354	0.366	8.70	9.0 BSC	9.30
E1	0.272	0.28	0.280	6.90	7.0 BSC	7.10
e*	0.016	0.020	0.024	0.40	0.50 BSC	0.60
L	0.018	0.24	0.030	0.45	0.60	0.75
∞	0.000°	4°	7.000°	0.00°	4°	7.00°

* Nominal pin pitch is 0.50 mm

*Controlling dimension is mm.

*JEDEC Designation: MS022

11.THERMAL CHARACTERISTICS AND SPECIFICATIONS

Parameters	Symbol	Min	Typ	Max	Units
Package Thermal Resistance (Note 1)	θ_{JA}	-	48	-	°C/Watt
	θ_{JC}	-	15	-	°C/Watt
Allowable Junction Temperature		-	-	125	°C

1. θ_{JA} is specified according to JEDEC specifications for multi-layer PCBs.

12. ORDERING INFORMATION

Product	Description	Package	Pb-Free	Grade	Temp Range	Container	Order #
CS4245	24-bit, 192 kHz Stereo Audio CODEC	48-LQFP	Yes	Commercial	-10° to +70° C	Tray	CS4245-CQZ
						Tape & Reel	CS4245-CQZR
CS4245	24-bit, 192 kHz Stereo Audio CODEC	48-LQFP	Yes	Automotive	-40° to +105° C	Tray	CS4245-DQZ
						Tape & Reel	CS4245-DQZR
CDB4245	CS4245 Evaluation Board		No	-	-	-	CDB4245

13. REVISION HISTORY

Release	Changes
F1	<ul style="list-style-type: none"> - Removed the MAP auto-increment functional description from the Control Port Description and Timing section beginning on page 37. - Added device revision information to the Chip ID - Register 01h description on page 42. - Updated the VQ1 Output Impedance specification in the DC Electrical Characteristics table on page 20. - Updated the Microphone Interchannel Isolation specification in the ADC Analog Characteristics table on page 15.
F2	<ul style="list-style-type: none"> - Added Automotive Grade - Changed MCLK1 and MCLK2 to input only in the Pin Descriptions table on page 7. - Updated the DAC Analog Characteristics table on page 10. - Updated the ADC Analog Characteristics table on page 13. - Updated the Auxiliary Output Analog Characteristics table on page 17. - Updated the DC Electrical Characteristics table on page 20. - Updated the Digital Interface Characteristics table on page 21. - Updated the Switching Characteristics - Serial Audio Port 1 table on page 22. - Updated the Switching Characteristics - Control Port - SPI Format table on page 28. - Updated the Typical Connection Diagram on page 29. - Switched Channel B PGA Control - Address 07h on page 47 and Channel A PGA Control - Address 08h on page 47.
F3	<ul style="list-style-type: none"> - Added Table 3.

Contacting Cirrus Logic Support

For all product questions and inquiries, contact a Cirrus Logic Sales Representative.
To find the one nearest you, go to www.cirrus.com

IMPORTANT NOTICE

Cirrus Logic, Inc. and its subsidiaries ("Cirrus") believe that the information contained in this document is accurate and reliable. However, the information is subject to change without notice and is provided "AS IS" without warranty of any kind (express or implied). Customers are advised to obtain the latest version of relevant information to verify, before placing orders, that information being relied on is current and complete. All products are sold subject to the terms and conditions of sale supplied at the time of order acknowledgment, including those pertaining to warranty, indemnification, and limitation of liability. No responsibility is assumed by Cirrus for the use of this information, including use of this information as the basis for manufacture or sale of any items, or for infringement of patents or other rights of third parties. This document is the property of Cirrus and by furnishing this information, Cirrus grants no license, express or implied under any patents, mask work rights, copyrights, trademarks, trade secrets or other intellectual property rights. Cirrus owns the copyrights associated with the information contained herein and gives consent for copies to be made of the information only for use within your organization with respect to Cirrus integrated circuits or other products of Cirrus. This consent does not extend to other copying such as copying for general distribution, advertising or promotional purposes, or for creating any work for resale.

CERTAIN APPLICATIONS USING SEMICONDUCTOR PRODUCTS MAY INVOLVE POTENTIAL RISKS OF DEATH, PERSONAL INJURY, OR SEVERE PROPERTY OR ENVIRONMENTAL DAMAGE ("CRITICAL APPLICATIONS"). CIRRUS PRODUCTS ARE NOT DESIGNED, AUTHORIZED OR WARRANTED FOR USE IN AIRCRAFT SYSTEMS, MILITARY APPLICATIONS, PRODUCTS SURGICALLY IMPLANTED INTO THE BODY, AUTOMOTIVE SAFETY OR SECURITY DEVICES, LIFE SUPPORT PRODUCTS OR OTHER CRITICAL APPLICATIONS. INCLUSION OF CIRRUS PRODUCTS IN SUCH APPLICATIONS IS UNDERSTOOD TO BE FULLY AT THE CUSTOMER'S RISK AND CIRRUS DISCLAIMS AND MAKES NO WARRANTY, EXPRESS, STATUTORY OR IMPLIED, INCLUDING THE IMPLIED WARRANTIES OF MERCHANTABILITY AND FITNESS FOR PARTICULAR PURPOSE, WITH REGARD TO ANY CIRRUS PRODUCT THAT IS USED IN SUCH A MANNER. IF THE CUSTOMER OR CUSTOMER'S CUSTOMER USES OR PERMITS THE USE OF CIRRUS PRODUCTS IN CRITICAL APPLICATIONS, CUSTOMER AGREES, BY SUCH USE, TO FULLY INDEMNIFY CIRRUS, ITS OFFICERS, DIRECTORS, EMPLOYEES, DISTRIBUTORS AND OTHER AGENTS FROM ANY AND ALL LIABILITY, INCLUDING ATTORNEYS' FEES AND COSTS, THAT MAY RESULT FROM OR ARISE IN CONNECTION WITH THESE USES.

Cirrus Logic, Cirrus, the Cirrus Logic logo designs, and Popguard are trademarks of Cirrus Logic, Inc. All other brand and product names in this document may be trademarks or service marks of their respective owners.

IP3 is a registered trademark of Philips Semiconductor.

SPI is a trademark of Motorola, Inc.

Looking for pricing, stock, or lifecycle information?

Click below to explore more details on WIN SOURCE:

[View CS4245-CQZR on WIN SOURCE](#)

[Cirrus Logic Inc. Information](#)

Optimize Your Supply Chain with WIN SOURCE Solutions

- ✓ Global Sourcing Solution
- ✓ Obsolete Management
- ✓ Cost Control Management
- ✓ Shortage Management
- ✓ Alternative Solution
- ✓ Excess Inventory Management