



**THE DATASHEET OF  
KSD1412S**



## KSD2 SERIES

### Interval Timer

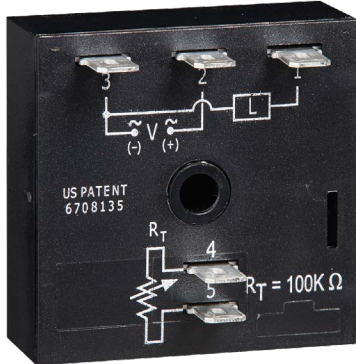

### Wiring Diagram

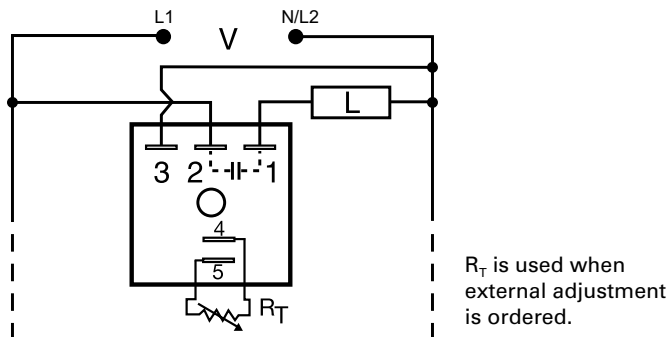

### Description

The KSD2 Series is designed for general purpose commercial and industrial applications where a small, cost effective, reliable, solid-state timer is required. The factory calibration for fixed time delays is within 5% of the target time delay. The repeat accuracy, under stable conditions, is 0.5% of the selected time delay. This series is designed for input voltages of 24, 120 or 230VAC. Time delays of 0.1 seconds to 1000 minutes are available in 6 ranges. The output is rated 1A steady and 10A inrush. The modules are totally solid state and encapsulated to protect the electronic circuitry. An excellent choice for most OEM pulse shaping, maximum run time, and other process control applications.

### Operation (Interval)

Upon application of input voltage, the time delay begins. The output energizes during the time delay. At the end of the time delay, the output de-energizes and remains de-energized until input voltage is removed.

**Reset:** Removing input voltage resets the time delay and the output.

### Features & Benefits

FEATURES	BENEFITS
<b>Microcontroller based</b>	Repeat Accuracy +/- 0.5%, +/- 5% time delay accuracy
<b>Compact, low cost design</b>	Allows flexibility for OEM applications
<b>1A Steady solid-state output, 10A inrush</b>	Provides 100 million operations in typical conditions.
<b>Totally solid state and encapsulated</b>	No moving parts to arc and wear out over time and encapsulated to protect against shock, vibration, and humidity

### Accessories



**P1004-95, P1004-95-X Versa-Pot**  
Panel mountable, industrial potentiometer recommended for remote time delay adjustment.



**P1023-6 Mounting bracket**  
The 90° orientation of mounting slots makes installation/removal of modules quick and easy.



**P0700-7 Versa-Knob**  
Designed for 0.25 in. (6.35 mm) shaft of Versa-Pot. Semi-gloss industrial black finish.



**P1015-64 (AWG 14/16) Female Quick Connect**  
These 0.25 in. (6.35 mm) female terminals are constructed with an insulator barrel to provide strain relief.

### Ordering Information

MODEL	INPUT VOLTAGE VAC	ADJUSTMENT	TIME DELAY
KSD2221	24	External	1 - 100s
KSD2413M	120	Fixed	3m
KSD2420	120	External	0.1 - 10s

If you don't find the part you need, call us for a custom product 800-843-8848

## KSD2 SERIES

### Accessories



**P1015-18 Quick Connect to Screw Adapter**  
Screw adapter terminal designed for use with all modules with 0.25 in. (6.35 mm) male quick connect terminals.



**C103PM (AL) DIN Rail**  
35 mm aluminum DIN rail available in a 36 in. (91.4 cm) length.



**P1023-20 DIN Rail Adapter**  
Allows module to be mounted on a 35 mm DIN type rail with two #10 screws.

### External Resistance vs. Time Delay

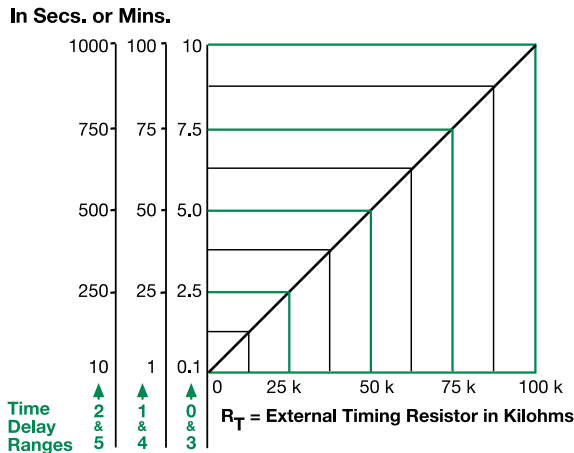

**This chart applies to externally adjustable part numbers.**  
The time delay is adjustable over the time delay range selected by varying the resistance across the  $R_T$  terminals; as the resistance increases the time delay increases.

When selecting an external  $R_T$ , add the tolerances of the timer and the  $R_T$  for the full time range adjustment.

**Examples:** 1 to 50 S adjustable time delay, select time delay range 1 and a 50 K ohm  $R_T$ . For 1 to 100 S use a 100 K ohm  $R_T$ .

### Function Diagram

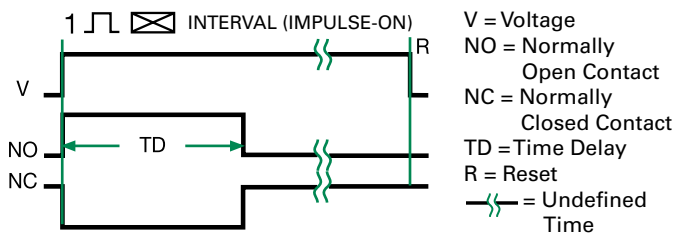

### Specifications

<b>Time Delay Range</b>	0.1s - 1000m in 6 adjustable ranges or fixed
<b>Repeat Accuracy Tolerance (Factory Calibration)</b>	$\pm 0.5\%$ or 20ms, whichever is greater
<b>Reset Time</b>	$\leq \pm 5\%$
<b>Time Delay vs. Temperature &amp; Voltage</b>	$\leq 150\text{ms}$
<b>Input Voltage</b>	$\leq \pm 10\%$
<b>Tolerance</b>	24, 120, or 230VAC
<b>AC Line Frequency</b>	$\pm 20\%$
<b>Power Consumption</b>	50/60 Hz
<b>Output Type</b>	$\leq 2\text{VA}$
<b>Form</b>	Solid state
<b>Maximum Load Current</b>	NO, closed during timing
<b>OFF State Leakage Current</b>	1A steady state, 10A inrush at 60°C
<b>Voltage Drop</b>	$\approx 5\text{mA @ 230VAC}$
<b>Protection</b>	$\approx 2.5\text{V @ 1A}$
<b>Circuitry</b>	Encapsulated
<b>Dielectric Breakdown</b>	$\geq 2000\text{V RMS terminals to mounting surface}$
<b>Insulation Resistance</b>	$\geq 100\text{M}\Omega$
<b>Mechanical Mounting</b>	Surface mount with one #10 (M5 x 0.8) screw
<b>Dimensions</b>	<b>H</b> 50.8 mm (2"); <b>W</b> 50.8 mm (2"); <b>D</b> 30.7 mm (1.21")
<b>Termination</b>	0.25 in. (6.35 mm) male quick connect terminals
<b>Environmental Operating/Storage Temperature</b>	-40° to 60°C / -40° to 85°C
<b>Humidity</b>	95% relative, non-condensing
<b>Weight</b>	$\approx 2.4\text{ oz (68 g)}$

## Looking for pricing, stock, or lifecycle information?

Click below to explore more details on WIN SOURCE:

 [View KSD1412S on WIN SOURCE](#)

 [Littelfuse Inc. Information](#)

## Optimize Your Supply Chain with WIN SOURCE Solutions

-  Global Sourcing Solution
-  Obsolete Management
-  Cost Control Management
-  Shortage Management
-  Alternative Solution
-  Excess Inventory Management