



**THE DATASHEET OF
NLHV1T0434ZR2G**



NLHV1T0434

48 V RF Antenna Switch Driver

The NLHV1T0434 MiniGate™ is an advanced high-voltage CMOS RF Antenna Switch Driver in ultra-small footprint.

Features

- Single Channel/High-Drive
- High-Speed/Low-Power
- Wide Operating V_{DD} Range: 3.0 V to 5.5 V
- Wide Output V_{CC} Range: 16 V to 50 V
- Low R_{DSon} :
 - NMOS = 10 Ω Max
 - PMOS = 200 Ω Max
- High output DC current: $I_{OL} \geq 130$ mA
- Max input frequency: 2 MHz minimum
- Low Static Current: I_{DDmax} , $I_{CCmax} = 100$ μ A
- Low Dynamic Current @ 100 kHz:
 - $I_{DDdynmax} = 0.2$ mA, $I_{CCdynmax} = 1.0$ mA
- Available in MSOP8-EP
- These Devices are Pb-Free, Halogen-Free/BFR-Free and are RoHS-Compliant



ON Semiconductor®

www.onsemi.com

MARKING DIAGRAM



MSOP-8
Z SUFFIX
CASE 846AM

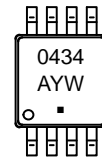

0434 = Specific Device Code
A = Assembly Location
Y = Year
W = Work Week
▪ = Pb-Free Package

(Note: Microdot may be in either location)

PIN CONNECTIONS

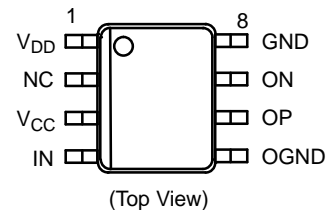

ORDERING INFORMATION

Device	Package	Shipping†
NLHV1T0434ZR2G	MSOP8-EP (Pb-Free)	3000 / Tape & Reel

†For information on tape and reel specifications, including part orientation and tape sizes, please refer to our Tape and Reel Packaging Specification Brochure, BRD8011/D.

NLHV1T0434

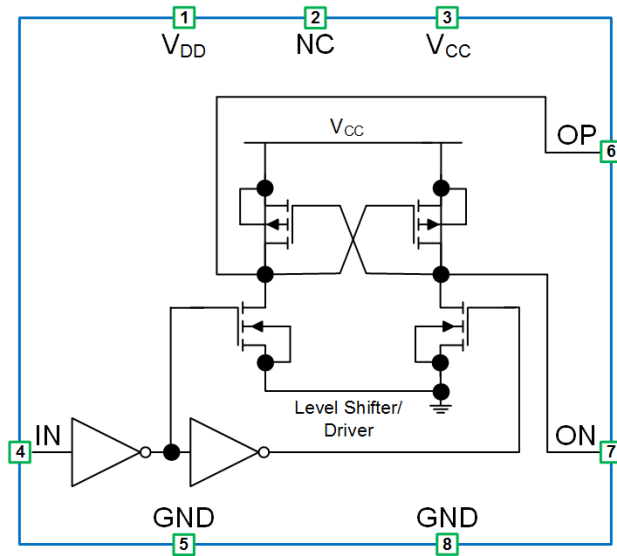

Figure 1. Block Diagram

Table 1. PIN ASSIGNMENT

Pin	Pin Name	Description
1	V _{DD}	Digital Power Supply
2	NC	No Connect
3	V _{CC}	High Voltage Supply
4	IN	Input
5	GND	Ground
6	OP	Non-Inverted Output
7	ON	Inverted Output
8	GND	Ground

Table 2. FUNCTION TABLE

Input	Output	
	OP	ON
A		
L	L	H
H	H	L

NLHV1T0434

Table 3. MAXIMUM RATINGS

Symbol	Parameter	Value	Unit
V _{DD}	Digital Supply Voltage	-0.5 to +7.0	V
V _{CC}	High-Voltage Supply Voltage	-0.5 to +55.0	V
V _{IN}	DC Input Voltage	-0.5 to +7.0	V
V _{OUT}	DC Output Voltage	-0.5 to V _{CC} + 0.5	V
I _{IK}	DC Input Diode Current V _{IN} < GND	-20	mA
I _{OK}	DC Output Diode Current V _{OUT} > V _{CC} , V _{OUT} < GND	±200	mA
I _O	DC Output Source/Sink Current	±200	mA
I _{CC}	DC Supply Current Per Supply Pin	±200	mA
I _{GND}	DC Ground Current per Ground Pin	±200	mA
T _{STG}	Storage Temperature Range	-65 to +150	°C
T _L	Lead Temperature, 1 mm from Case for 10 Seconds	260	°C
T _J	Junction Temperature Under Bias	150	°C
MSL	Moisture Sensitivity	Level 1	
F _R	Flammability Rating Oxygen Index: 28 to 34	UL 94 V-0 @ 0.125 in	
V _{ESD}	ESD Withstand Voltage Human Body Mode (Note 2) Charged Device Model (Note 3)	> 4 > 2	kV
I _{LATCHUP}	Latchup Performance Above V _{CC} and Below GND at 125°C (Note 4)	±100	mA
SR _{VCC}	Minimum V _{CC} Rise Rate (Note 5)	5	µs/V

Stresses exceeding those listed in the Maximum Ratings table may damage the device. If any of these limits are exceeded, device functionality should not be assumed, damage may occur and reliability may be affected.

1. Measured with minimum pad spacing on an FR4 board, using 10 mm-by-1 inch, 2 ounce copper trace no air flow.
2. Tested to EIA / JESD22-A114-A.
3. Tested to JESD22-C101-A.
4. Tested to EIA / JESD78.
5. A faster V_{CC} rise rate could damage the output of the device.

Table 4. RECOMMENDED OPERATING CONDITIONS

Symbol	Parameter	Min	Max	Unit
V _{DD}	Digital Supply Voltage	3.0	5.5	V
V _{CC}	High Voltage Supply Voltage	16	50	V
V _{IN}	Digital Input Voltage	0	5.5	V
V _{OUT}	Output Voltage	0	V _{CC}	V
T _A	Operating Free-Air Temperature	-55	+125	°C
Δt / ΔV	Input Transition Rise or Fall Rate	0	20	nS/V

Functional operation above the stresses listed in the Recommended Operating Ranges is not implied. Extended exposure to stresses beyond the Recommended Operating Ranges limits may affect device reliability.

NLHV1T0434

Table 5. DC ELECTRICAL CHARACTERISTICS

Symbol	Parameter	Conditions	V _{DD} (V)	V _{CC} (V)	T _A = 25°C			T _A = -55°C to +125°C		Unit
					Min	Typ	Max	Min	Max	
V _{IH}	High-Level Input Voltage		3.0 to 5.5	16 to 50	1.7	-	-	1.7	-	V
V _{IL}	Low-Level Input Voltage		3.0 to 5.5	16 to 50	-	-	0.4	-	0.4	V
V _{OH}	High-Level Output Voltage	V _{IN} = V _{IH} or V _{IL} , I _{OH} = -100 μA	3.0 to 5.5	16 to 50	V _{CC} - 0.5	V _{CC}		V _{CC} - 0.5		V
V _{OL}	Low-Level Output Voltage	V _{IN} = V _{IH} or V _{IL} , I _{OL} = 10 mA	3.0 to 5.5	16 to 50	-	0.04	0.2	GND	0.2	V
I _{IN}	Input Leakage Current	V _{IN} = 0 to 5.5 V	3.0 to 5.5	16 to 50	-	-	±10	-	±10	μA
I _{DD}	Quiescent Supply Current	V _{IN} = V _{DD} or GND	3.0 to 5.5	16 to 50	-	50	100	-	100	μA
I _{CC}	Quiescent Supply Current	V _{IN} = V _{DD} or GND	3.0 to 5.5	16 to 50	-	50	100	-	100	μA
R _{ONN}	Output NMOS ON Resistance	I _{OL} = 130 mA	3.0 to 5.5	16 to 50	-	4	10	-	10	Ω
R _{ONNFLAT}	Output NMOS ON Resistance Flatness	I _{OL} = 130 mA	3.0 to 5.5	16 to 50	-	0.4	2	-	3	Ω
R _{ONP}	Output PMOS ON Resistance	I _{OH} = -100 μA	3.0 to 5.5	16 to 50	-	60	200	-	200	Ω

Product parametric performance is indicated in the Electrical Characteristics for the listed test conditions, unless otherwise noted. Product performance may not be indicated by the Electrical Characteristics if operated under different conditions.

NLHV1T0434

Table 6. AC ELECTRICAL CHARACTERISTICS (Input $t_r = t_f = 3.0$ nS)

Symbol	Parameter	Test Condition	V_{DD} (V)	V_{CC} (V)	$T_A = 25^\circ\text{C}$			$T_A = -55^\circ\text{C to } +125^\circ\text{C}$		Unit
					Min	Typ	Max	Min	Max	
t_{PHL}	High to Low Propagation Delay, IN to OP, ON	$C_L = 1$ nF	3.0 to 5.5	50	–	38	100	–	100	ns
				48	–	38	100	–	100	
				28	–	31	100	–	100	
				18	–	28	100	–	100	
		$C_L = 10$ pF	3.0 to 5.5	50	–	21	80	–	80	
				48	–	21	80	–	80	
				28	–	21	80	–	80	
				18	–	20	80	–	80	
t_{PLH}	Low to High Propagation Delay, IN to OP, ON	$C_L = 1$ nF	3.0 to 5.5	50	–	159	400	–	400	ns
				48	–	159	400	–	400	
				28	–	95	400	–	400	
				18	–	69	400	–	400	
		$C_L = 10$ pF	3.0 to 5.5	50	–	16	60	–	60	
				48	–	16	60	–	60	
				28	–	13	60	–	60	
				18	–	12	60	–	60	
t_F	Output Fall Time	$C_L = 1$ nF	3.0 to 5.5	50	–	28.5	100	–	100	ns
				48	–	28.5	100	–	100	
				28	–	19.3	100	–	100	
				18	–	14.5	100	–	100	
		$C_L = 10$ pF	3.0 to 5.5	50	–	4.1	50	–	50	
				48	–	4.1	50	–	50	
				28	–	3.0	50	–	50	
				18	–	2.1	50	–	50	
t_R	Output Rise Time	$C_L = 1$ nF	3.0 to 5.5	50	–	285.7	1000	–	1000	ns
				48	–	285.7	1000	–	1000	
				28	–	182.6	1000	–	1000	
				18	–	144.4	1000	–	1000	
		$C_L = 10$ pF	3.0 to 5.5	50	–	8.6	50	–	50	
				48	–	8.6	50	–	50	
				28	–	5.1	50	–	50	
				18	–	4.4	50	–	50	
I_{DD-DYN}	Dynamic Current at V_{DD}	$f = 100$ kHz; ON, OP open	3.0 to 5.5	16 to 50		0.1	0.2		0.2	mA
I_{CC-DYN}	Dynamic Current at V_{CC}	$f = 100$ kHz; ON, OP open	3.0 to 5.5	16 to 50		0.5	1.0		1.0	mA
f	Maximum Input Frequency	ON, OP open	3.0 to 5.5	16 to 50	2			2		MHz

NLHV1T0434

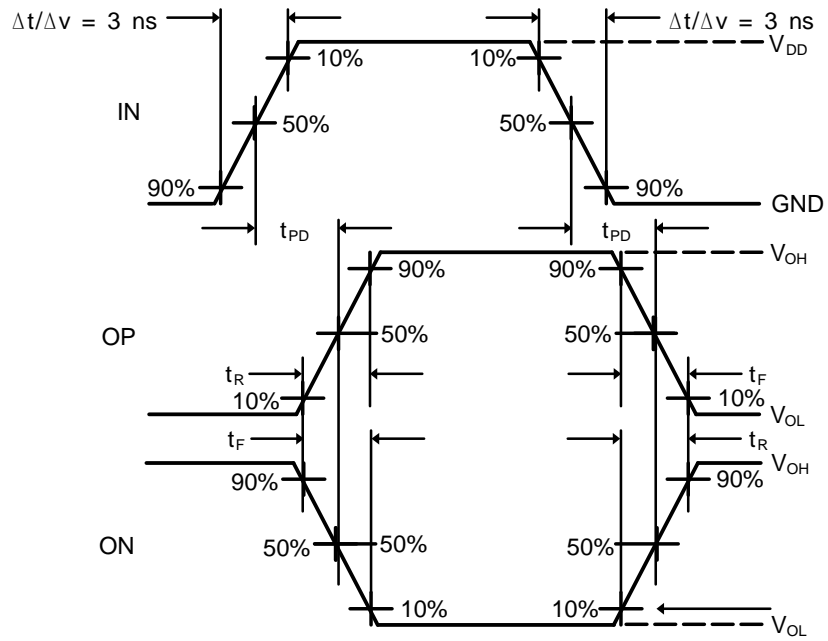

Figure 2. Switching Waveforms

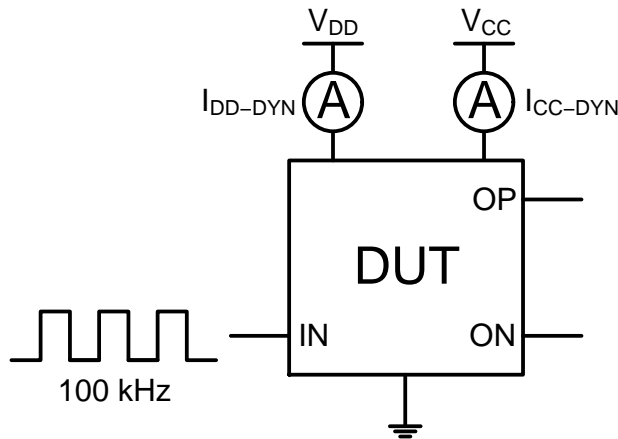
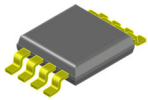

Figure 3. Test Set-up for Dynamic Current

MECHANICAL CASE OUTLINE PACKAGE DIMENSIONS



MSOP8 EP, 3x3 CASE 846AM ISSUE B

DATE 07 JAN 2022

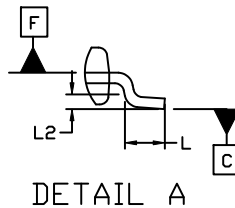
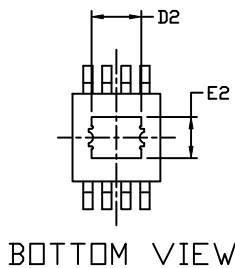
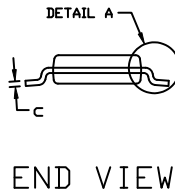
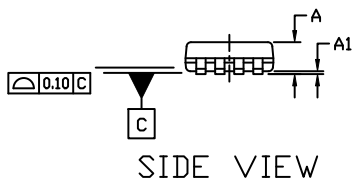
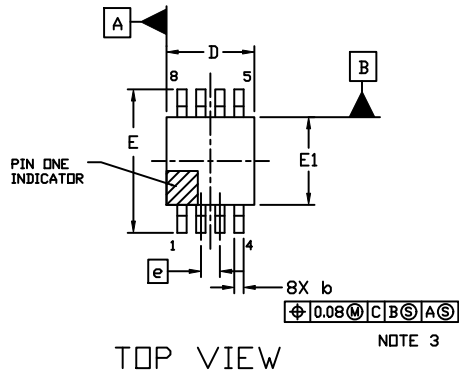

NOTES:

- DIMENSIONING AND TOLERANCING PER ASME Y14.5M, 1994.
- CONTROLLING DIMENSION: MILLIMETERS
- DIMENSION *b* DOES NOT INCLUDE DAMBAR PROTRUSION. ALLOWABLE PROTRUSION SHALL BE 0.10 mm IN EXCESS OF MAXIMUM MATERIAL CONDITION.
- DIMENSION *D* DOES NOT INCLUDE MOLD FLASH, PROTRUSIONS, OR GATE BURRS. MOLD FLASH, PROTRUSIONS, OR GATE BURRS SHALL NOT EXCEED 0.15 mm PER SIDE. DIMENSION *E* DOES NOT INCLUDE INTERLEAD FLASH OR PROTRUSION. INTERLEAD FLASH OR PROTRUSION SHALL NOT EXCEED 0.25 mm PER SIDE. DIMENSIONS *D* AND *E* ARE DETERMINED AT DATUM *F*.
- DATUMS *A* AND *B* ARE TO BE DETERMINED AT DATUM *F*.
- A1* IS DEFINED AS THE VERTICAL DISTANCE FROM THE SEATING PLANE TO THE LOWEST POINT ON THE PACKAGE BODY.

DIM	MILLIMETERS	
	MIN.	MAX.
A	---	1.10
A1	0.05	0.15
<i>b</i>	0.25	0.40
<i>c</i>	0.13	0.23
<i>D</i>	2.90	3.10
<i>D2</i>	1.73	1.83
<i>E</i>	4.75	5.05
<i>E1</i>	2.90	3.10
<i>E2</i>	1.37	1.47
<i>e</i>	0.65 BSC	
<i>L</i>	0.40	0.70
<i>L2</i>	0.254 BSC	

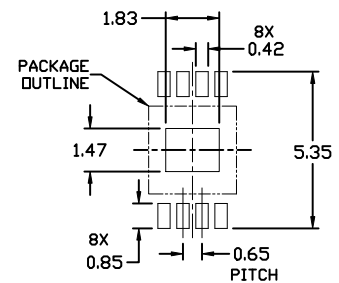

* FOR ADDITIONAL INFORMATION ON OUR Pb-FREE STRATEGY AND SOLDERING DETAILS, PLEASE DOWNLOAD THE ONSEMI SOLDERING AND MOUNTING TECHNIQUES REFERENCE MANUAL, SOLDERM/D.

GENERIC MARKING DIAGRAM*

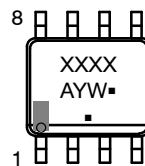

- XXXX = Specific Device Code
- A = Assembly Location
- Y = Year
- W = Work Week
- = Pb-Free Package

(Note: Microdot may be in either location)
*This information is generic. Please refer to device data sheet for actual part marking. Pb-Free indicator, "G" or microdot "▪", may or may not be present. Some products may not follow the Generic Marking.

DOCUMENT NUMBER:	98AON82708F	Electronic versions are uncontrolled except when accessed directly from the Document Repository. Printed versions are uncontrolled except when stamped "CONTROLLED COPY" in red.
DESCRIPTION:	MSOP8 EP, 3X3	PAGE 1 OF 1

onsemi and onsemi are trademarks of Semiconductor Components Industries, LLC dba onsemi or its subsidiaries in the United States and/or other countries. onsemi reserves the right to make changes without further notice to any products herein. onsemi makes no warranty, representation or guarantee regarding the suitability of its products for any particular purpose, nor does onsemi assume any liability arising out of the application or use of any product or circuit, and specifically disclaims any and all liability, including without limitation special, consequential or incidental damages. onsemi does not convey any license under its patent rights nor the rights of others.

onsemi, **Onsemi**, and other names, marks, and brands are registered and/or common law trademarks of Semiconductor Components Industries, LLC dba "**onsemi**" or its affiliates and/or subsidiaries in the United States and/or other countries. **onsemi** owns the rights to a number of patents, trademarks, copyrights, trade secrets, and other intellectual property. A listing of **onsemi**'s product/patent coverage may be accessed at www.onsemi.com/site/pdf/Patent-Marking.pdf. **onsemi** reserves the right to make changes at any time to any products or information herein, without notice. The information herein is provided "as-is" and **onsemi** makes no warranty, representation or guarantee regarding the accuracy of the information, product features, availability, functionality, or suitability of its products for any particular purpose, nor does **onsemi** assume any liability arising out of the application or use of any product or circuit, and specifically disclaims any and all liability, including without limitation special, consequential or incidental damages. Buyer is responsible for its products and applications using **onsemi** products, including compliance with all laws, regulations and safety requirements or standards, regardless of any support or applications information provided by **onsemi**. "Typical" parameters which may be provided in **onsemi** data sheets and/or specifications can and do vary in different applications and actual performance may vary over time. All operating parameters, including "Typicals" must be validated for each customer application by customer's technical experts. **onsemi** does not convey any license under any of its intellectual property rights nor the rights of others. **onsemi** products are not designed, intended, or authorized for use as a critical component in life support systems or any FDA Class 3 medical devices or medical devices with a same or similar classification in a foreign jurisdiction or any devices intended for implantation in the human body. Should Buyer purchase or use **onsemi** products for any such unintended or unauthorized application, Buyer shall indemnify and hold **onsemi** and its officers, employees, subsidiaries, affiliates, and distributors harmless against all claims, costs, damages, and expenses, and reasonable attorney fees arising out of, directly or indirectly, any claim of personal injury or death associated with such unintended or unauthorized use, even if such claim alleges that **onsemi** was negligent regarding the design or manufacture of the part. **onsemi** is an Equal Opportunity/Affirmative Action Employer. This literature is subject to all applicable copyright laws and is not for resale in any manner.

ADDITIONAL INFORMATION

TECHNICAL PUBLICATIONS:

Technical Library: www.onsemi.com/design/resources/technical-documentation
onsemi Website: www.onsemi.com

ONLINE SUPPORT: www.onsemi.com/support

For additional information, please contact your local Sales Representative at www.onsemi.com/support/sales

Looking for pricing, stock, or lifecycle information?

Click below to explore more details on WIN SOURCE:

- ⊖ [View NLHV1T0434ZR2G on WIN SOURCE](#)
- ⊖ [ON Semiconductor](#) Information

Optimize Your Supply Chain with WIN SOURCE Solutions

- ✓ Global Sourcing Solution
- ✓ Obsolete Management
- ✓ Cost Control Management
- ✓ Shortage Management
- ✓ Alternative Solution
- ✓ Excess Inventory Management