



**THE DATASHEET OF
PS8352AL2-V-E3-AX**



PS8352AL2

R08DS0132EJ0101

ANALOG OUTPUT TYPE
OPTICAL COUPLED ISOLATION AMPLIFIER

Rev.1.01

May 25, 2021

DESCRIPTION

The PS8352AL2 is an optically coupled isolation amplifier that uses an IC with a high-accuracy sigma-delta A/D converter and an AlGaAs light-emitting diode with high-speed response and high luminance efficiency on the input side, and an IC with a high-accuracy D/A converter on the output side.

The PS8352AL2 is designed specifically for high common mode transient immunity (CMTI) and high linearity (non-linearity). The PS8352AL2 is designed for current and voltage sensing.

FEATURES

- Non-linearity (NL200 = 0.35 % MAX.)
- High common mode transient immunity (CMTI = 10 kV/ μ s MIN.)
- High isolation voltage (BV = 5 000 Vr.m.s.)
- Gain tolerance (G = 7.92 to 8.08 (\pm 1 %))
Gain: 8 V/V TYP.
- Package: 8-pin DIP lead bending type for long creepage distance for surface mount (L2)
- Embossed tape product: PS8352AL2-E3: 2 000 pcs/reel
- Pb-Free product
- Safety standards
 - UL approved: UL1577, Double protection
 - CSA approved: CAN/CSA-C22.2 62368-1, Reinforced insulation
 - VDE approved: DIN EN 60747-5-5 (Option)

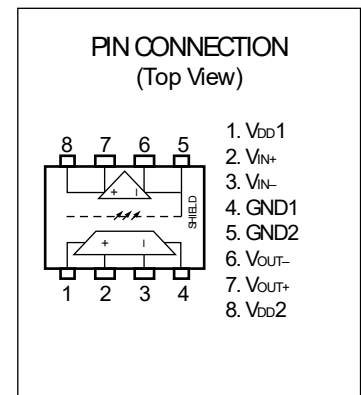

APPLICATIONS

- AC Servo, inverter
- Solar power conditioner
- Measurement equipment

Start of mass production
2015-09

PACKAGE DIMENSIONS (UNIT: mm)

Lead Bending Type (Gull-wing) For Long Creepage Distance For Surface Mount (L2)

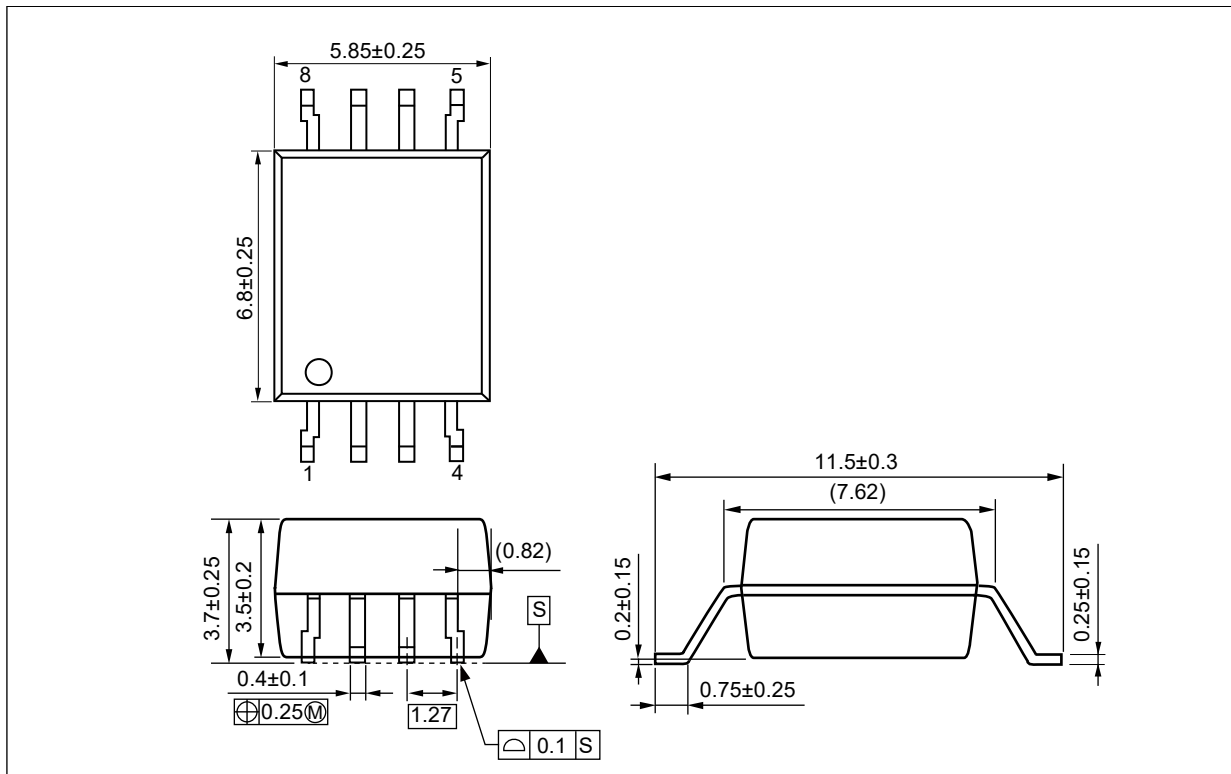

Weight: 0.316g (typ.)

PHOTOCOUPLER CONSTRUCTION

| Parameter | MIN. |
|--------------------|--------|
| Air Distance | 8 mm |
| Creepage Distance | 8 mm |
| Isolation Distance | 0.4 mm |

MARKING EXAMPLE

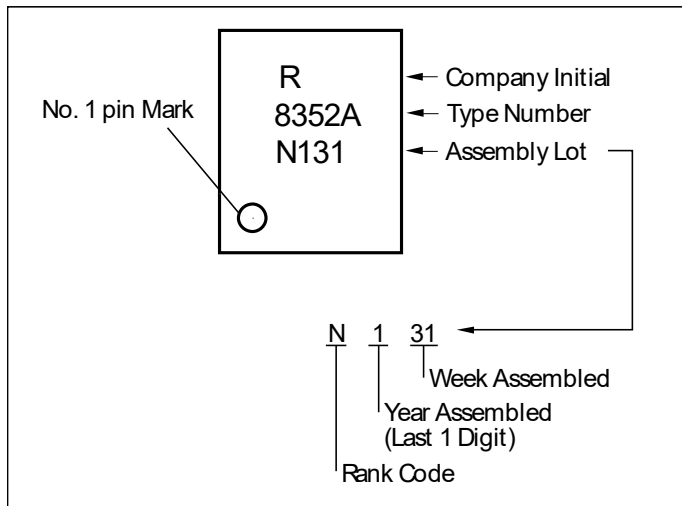

ORDERING INFORMATION

| Part Number | Order Number | Solder Plating Specification | Packing Style | Safety Standard Approval | Application Part Number*1 |
|----------------|-------------------|------------------------------|---------------------------------|--------------------------------------|---------------------------|
| PS8352AL2 | PS8352AL2-AX | Pb-Free (Ni/Pd/Au) | 20 pcs (Tape 20 pcs cut) | Standard products (UL, CSA approved) | PS8352AL2 |
| PS8352AL2-E3 | PS8352AL2-E3-AX | | Embossed Tape 2 000 pcs/reel | | |
| PS8352AL2-V | PS8352AL2-V-AX | | 20 pcs (Tape 20 pcs cut) | UL, CSA, DIN EN 60747-5-5 approved | |
| PS8352AL2-V-E3 | PS8352AL2-V-E3-AX | | Embossed Tape 2 000 pcs/reel | | |

Notes*: 1 For the application of the Safety Standard, following part number should be used.

ABSOLUTE MAXIMUM RATINGS ($T_A = 25\text{ }^\circ\text{C}$, unless otherwise specified)

| Parameter | Symbol | Ratings | Unit |
|-----------------------------------|----------------------|--------------------------|------------------|
| Operating Ambient Temperature | T_A | - 40 to +110 | $^\circ\text{C}$ |
| Storage Temperature | Tstg | - 55 to +125 | $^\circ\text{C}$ |
| Supply Voltage | V_{DD1}, V_{DD2} | 0 to 5.5 | V |
| Input Voltage | V_{IN+}, V_{IN-} | - 2 to $V_{DD1} + 0.5$ | V |
| 2 Seconds Transient Input Voltage | V_{IN+}, V_{IN-} | - 6 to $V_{DD1} + 0.5$ | V |
| Output Voltage | V_{OUT+}, V_{OUT-} | - 0.5 to $V_{DD2} + 0.5$ | V |
| Isolation Voltage*1 | BV | 5 000 | Vr.m.s. |

Notes*: 1. AC voltage for 1 minute at $T_A = 25\text{ }^\circ\text{C}$, RH = 60 % between input and output.
Pins 1-4 shorted together, 5-8 shorted together.

RECOMMENDED OPERATING CONDITIONS

| Parameter | Symbol | MIN. | MAX. | Unit |
|--|--------------------|-------|------|------------------|
| Operating Ambient Temperature | T_A | - 40 | 110 | $^\circ\text{C}$ |
| Supply Voltage | V_{DD1}, V_{DD2} | 4.5 | 5.5 | V |
| Input Voltage (Accurate and Linear)*1 | V_{IN+}, V_{IN-} | - 200 | 200 | mV |

Notes*: 1. Using $V_{IN-} = 0\text{ V}$ (to be connected to GND1) is recommended. Avoid using V_{IN-} of 2.5 V or more, because the internal test mode is activated when the voltage V_{IN-} reaches more than 2.5 V.

ELECTRICAL CHARACTERISTICS (DC Characteristics)

(TYP.: $T_A = 25\text{ }^\circ\text{C}$, $V_{IN+} = V_{IN-} = 0\text{ V}$, $V_{DD1} = V_{DD2} = 5\text{ V}$,
MIN., MAX.: refer to RECOMMENDED OPERATING CONDITIONS, unless otherwise specified)

| Parameter | Symbol | Conditions | MIN. | TYP. | MAX. | Unit |
|---|--------------------|--|------|--------|------|------------------------------|
| Input Offset Voltage | V _{OS} | $T_A = 25\text{ }^\circ\text{C}$ | - 2 | - 0.25 | 2 | mV |
| | | | - 3 | - 0.25 | 3 | |
| Input Offset Voltage Drift vs. Temperature | $ dV_{OS}/dT_A $ | | | 1.6 | 10 | $\mu\text{V}/^\circ\text{C}$ |
| Gain *1 | G | $-200\text{ mV} \leq V_{IN+} \leq 200\text{ mV}$, $T_A = 25\text{ }^\circ\text{C}$ | 7.92 | 8 | 8.08 | V/V |
| Gain Drift vs. Temperature | $ dG/dT_A $ | | | 0.0006 | | V/V $^\circ\text{C}$ |
| V _{OUT} Non-linearity (200 mV) *2 | NL200 | $-200\text{ mV} \leq V_{IN+} \leq 200\text{ mV}$ | | 0.014 | 0.35 | % |
| V _{OUT} Non-linearity (200 mV) Drift vs. Temperature | $ dNL200/dT_A $ | | | 0.0001 | | %/ $^\circ\text{C}$ |
| V _{OUT} Non-linearity (100 mV) *2 | NL100 | $-100\text{ mV} \leq V_{IN+} \leq 100\text{ mV}$ | | 0.011 | 0.2 | % |
| Maximum Input Voltage before V _{OUT} Clipping | $ V_{IN+} $ MAX. | | | 320 | | mV |
| Input Supply Current | I _{DD1} | $V_{IN+} = 400\text{ mV}$ | | 13.5 | 16 | mA |
| Output Supply Current | I _{DD2} | $V_{IN+} = -400\text{ mV}$ | | 7.8 | 16 | mA |
| Input Bias Current | I _{IN+} | $V_{IN+} = 0\text{ V}$ | - 1 | - 0.65 | 1 | μA |
| Input Bias Current Drift vs. Temperature | $ dI_{IN+}/dT_A $ | | | 0.3 | | nA/ $^\circ\text{C}$ |
| Low Level Saturated Output Voltage | V _{OL} | $V_{IN+} = -400\text{ mV}$ | | 1.29 | | V |
| High Level Saturated Output Voltage | V _{OH} | $V_{IN+} = 400\text{ mV}$ | | 3.8 | | V |
| Output Voltage ($V_{IN+} = V_{IN-} = 0\text{ V}$) | V _{OCM} | $V_{IN+} = V_{IN-} = 0\text{ V}$ | 2.2 | 2.55 | 2.8 | V |
| Output Short-circuit Current | I _{OSC} | | | 20 | | mA |
| Equivalent Input Resistance | R _{IN} | | | 450 | | k Ω |
| V _{OUT} Output Resistance | R _{OUT} | | | 4 | | Ω |
| Input DC Common-Mode Rejection Ratio *3 | CMRR _{IN} | | | 76 | | dB |

- *1 The differential output voltage ($V_{OUT+} - V_{OUT-}$) with respect to the differential input voltage ($V_{IN+} - V_{IN-}$), where $V_{IN+} = -200\text{ mV}$ to 200 mV and $V_{IN-} = 0\text{ V}$ is measured under the circuit shown in **Fig. 2 NL200, G Test Circuit**. Upon the resulting chart, the gain is defined as the slope of the optimum line obtained by using the method of least squares.
- *2 The differential output voltage ($V_{OUT+} - V_{OUT-}$) with respect to the differential input voltage ($V_{IN+} - V_{IN-}$) is measured under the circuit shown in **Fig. 2 NL200, G Test Circuit**. Upon the resulting chart, the optimum line is obtained by using the method of least squares. Non-linearity is defined as the ratio (%) of the optimum line obtained by dividing [Half of the peak to peak value of the (residual) deviation] by [full-scale differential output voltage]. For example, if the differential output voltage is 3.2 V , and the peak to peak value of the (residual) deviation is 22.4 mV , while the input V_{IN+} is $\pm 200\text{ mV}$, the output non-linearity is obtained as follows:

$$NL200 = 22.4 / (2 \times 3200) = 0.35\%$$
- *3 CMRR_{IN} is defined as the ratio of the differential signal gain (when the differential signal is applied between the input pins) to the common-mode signal gain (when both input pins are connected and the signal is applied). This value is indicated in dB.

ELECTRICAL CHARACTERISTICS (AC Characteristics)

(TYP.: $T_A = 25\text{ }^\circ\text{C}$, $V_{IN+} = V_{IN-} = 0\text{ V}$, $V_{DD1} = V_{DD2} = 5\text{ V}$,
 MIN., MAX.: refer to RECOMMENDED OPERATING CONDITIONS, unless otherwise specified)

| Parameter | Symbol | Conditions | MIN. | TYP. | MAX. | Unit |
|--|------------|--|------|------|------|-------------------------|
| V_{OUT} Bandwidth (-3 dB) | f_C | $V_{IN+} = 200\text{ mVp-p}$, sine wave | 50 | 100 | | kHz |
| V_{OUT} Noise | N_{OUT} | $V_{IN+} = 0\text{ V}$ | | 15.6 | | mVr.m.s. |
| V_{IN} to V_{OUT} Signal Delay (50 to 10%) | t_{PD10} | $V_{IN+} = 0$ to 150 mV step | | 2.4 | 3.3 | μs |
| V_{IN} to V_{OUT} Signal Delay (50 to 50%) | t_{PD50} | | | 4.2 | 5.6 | |
| V_{IN} to V_{OUT} Signal Delay (50 to 90%) | t_{PD90} | | | 6.1 | 9.9 | |
| V_{OUT} Rise Time/Fall Time (10 to 90%) | t_r/t_f | $V_{IN+} = 0$ to 150 mV step | | 3.1 | 6.6 | μs |
| Common Mode Transient Immunity* ¹ | CMTI | $V_{CM} = 0.5\text{ kV}$, $t_r = 20\text{ ns}$, $T_A = 25\text{ }^\circ\text{C}$ | 10 | 28 | | $\text{kV}/\mu\text{s}$ |
| Power Supply Noise Rejection* ² | PSR | $f = 1\text{ MHz}$ | | 40 | | mVr.m.s. |

- *1 CMTI is tested by applying a pulse that rises and falls suddenly ($V_{CM} = 0.5\text{ kV}$) between GND1 on the input side and GND2 on the output side (pins 4 and 5) by using the circuit shown in **Fig. 9 CMTI Test Circuit**. CMTI is defined at the point where the differential output voltage ($V_{OUT+} - V_{OUT-}$) fluctuates 200 mV ($>1\text{ }\mu\text{s}$) or more from the average output voltage.
- *2 This is the value of the transient voltage at the differential output when 1 V_{p-p}, 1 MHz, and 40 ns rise/fall time square wave is applied to both V_{DD1} and V_{DD2} .

TEST CIRCUIT

Fig. 1 Vos Test Circuit

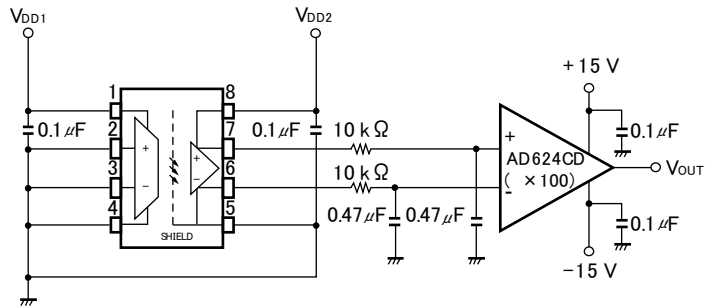

Fig. 2 NL200, G Test Circuit

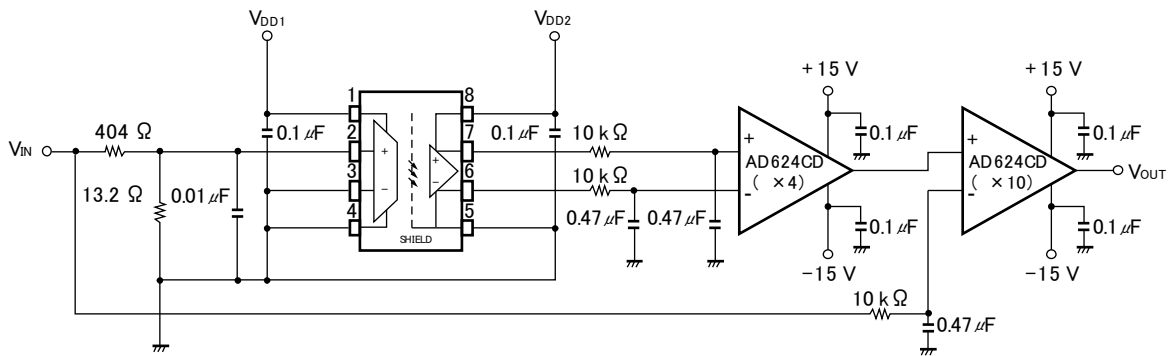

Fig. 3 I_{DD1} Test Circuit

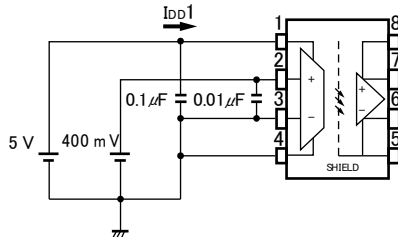

Fig. 4 I_{DD2} Test Circuit

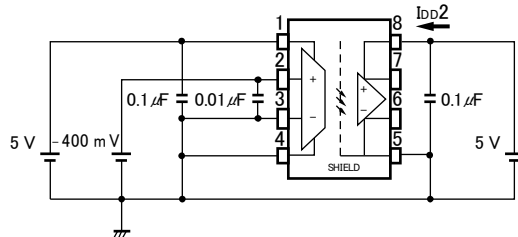

Fig. 5 IIN+ Test Circuit

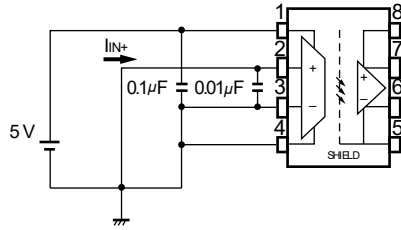
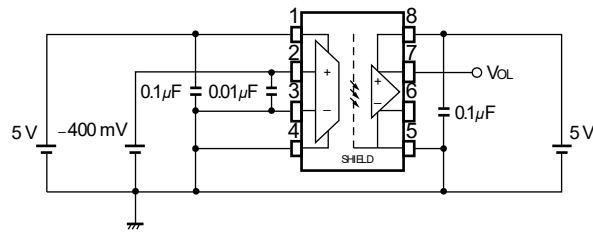
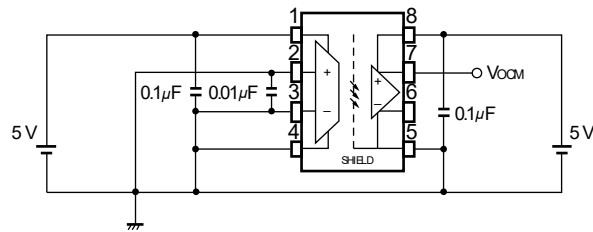

Fig. 6 VOUT Test Circuit

V_{OL}



V_{oCM}



V_{OH}

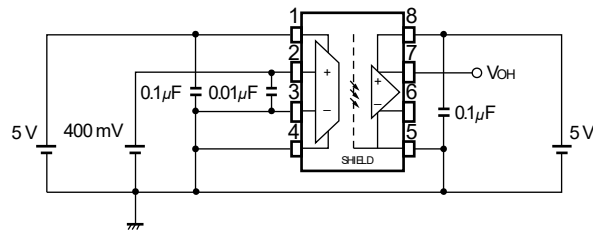

Fig. 7 |IOSC| Test Circuit

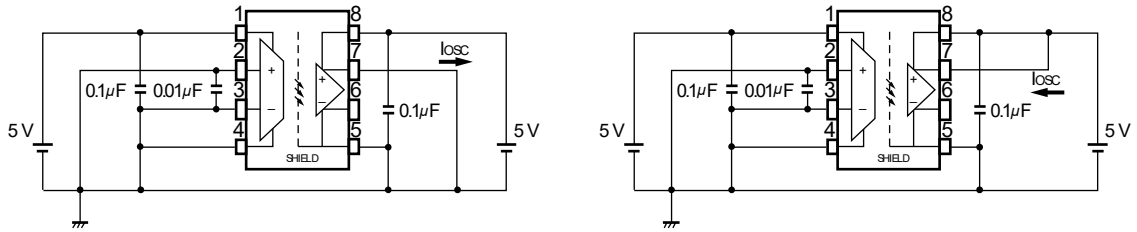

Fig. 8 tPD Test Circuit

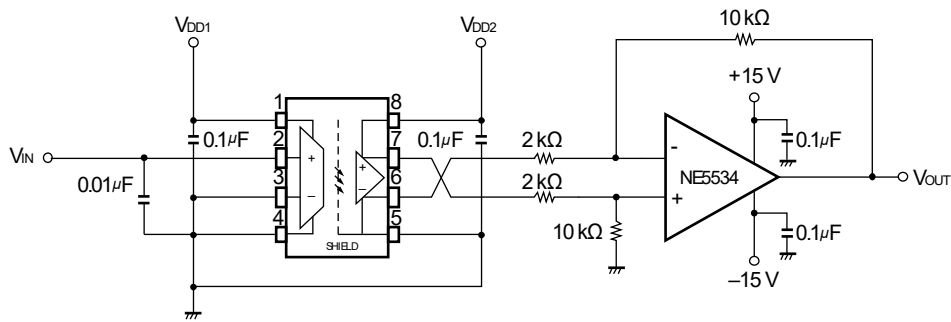
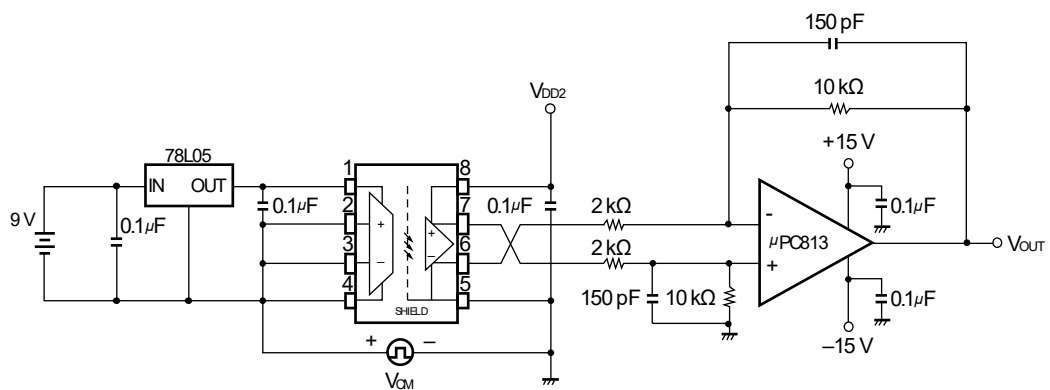
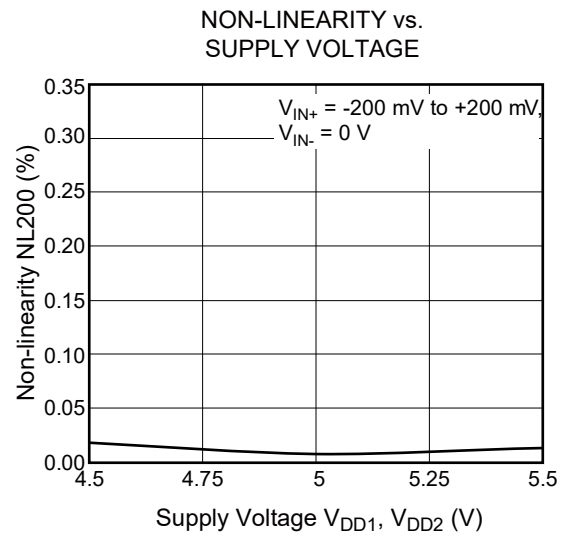
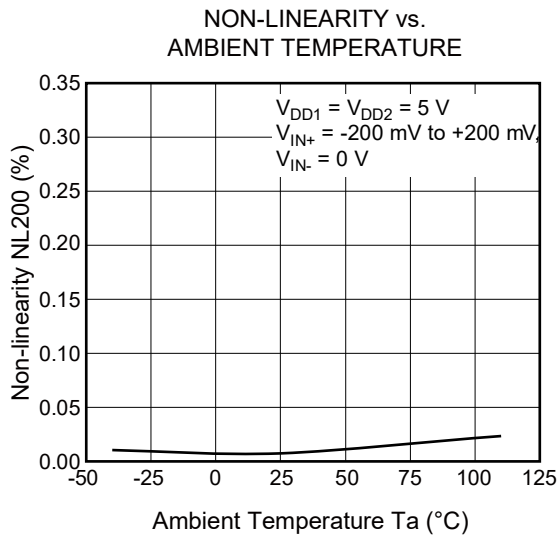
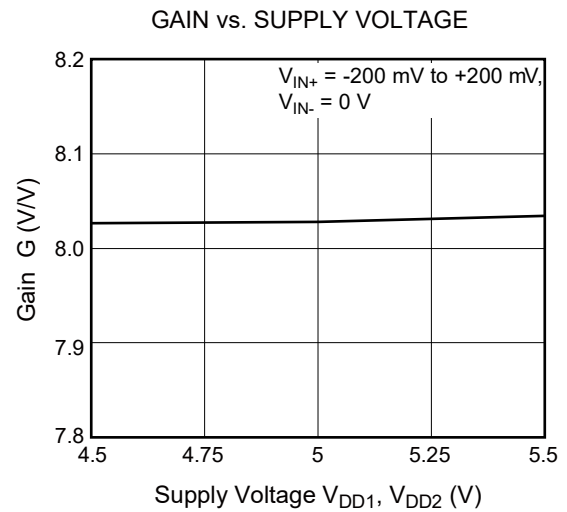
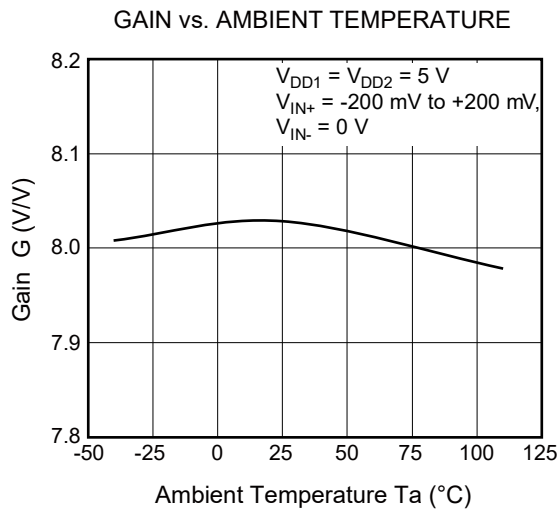
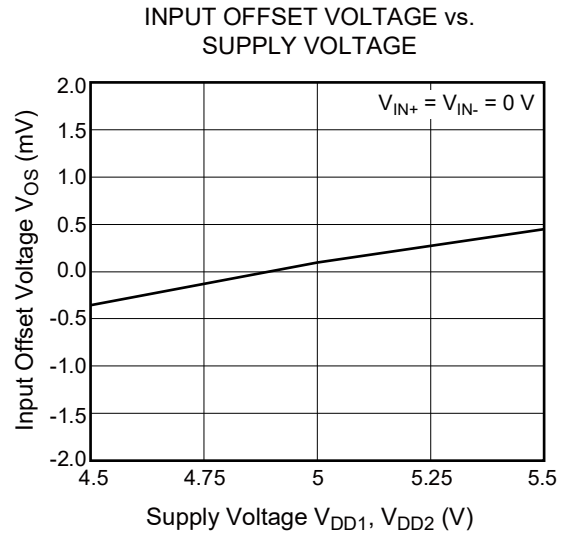
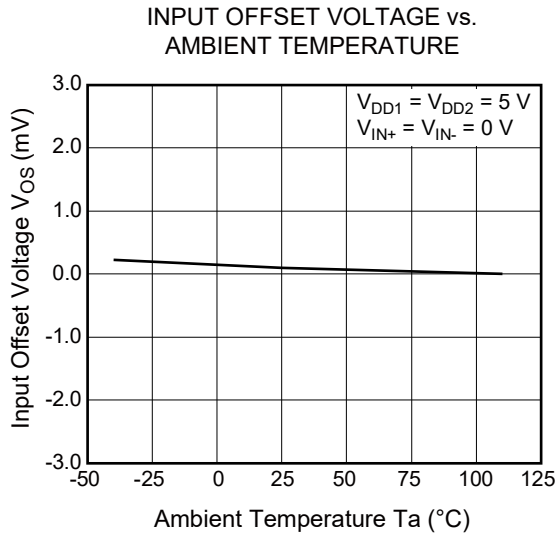

Fig. 9 CMTI Test Circuit



TYPICAL CHARACTERISTICS (T_A = 25 °C unless otherwise specified)



Remark The graphs indicate nominal characteristics.

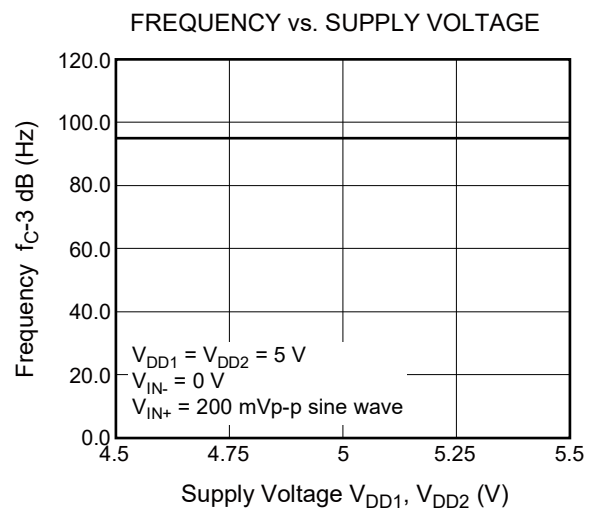
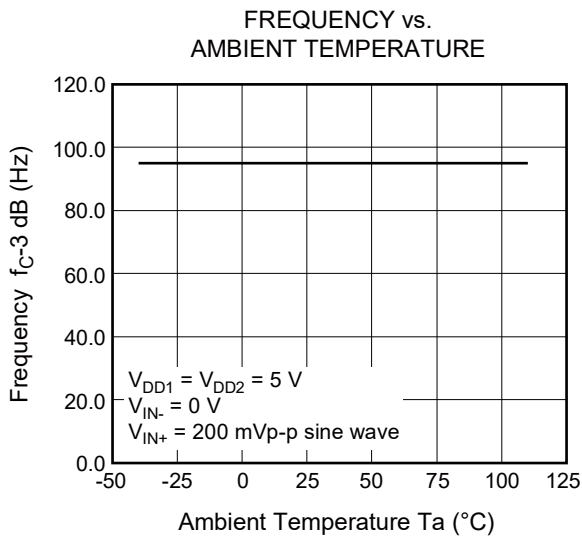
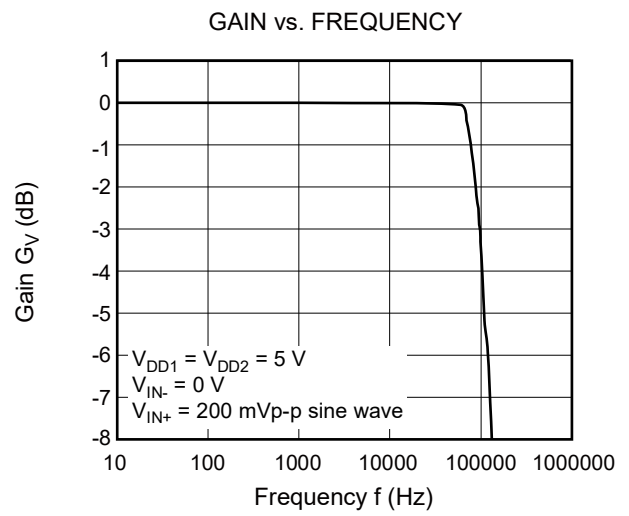
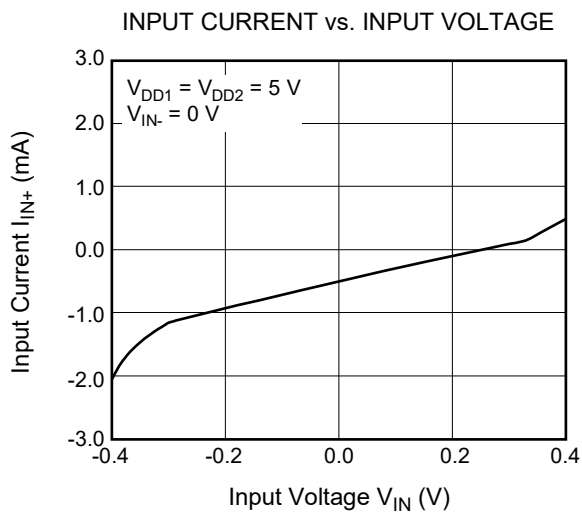
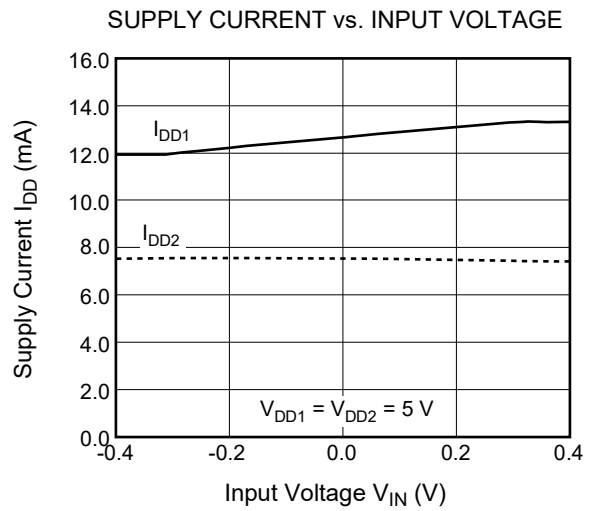
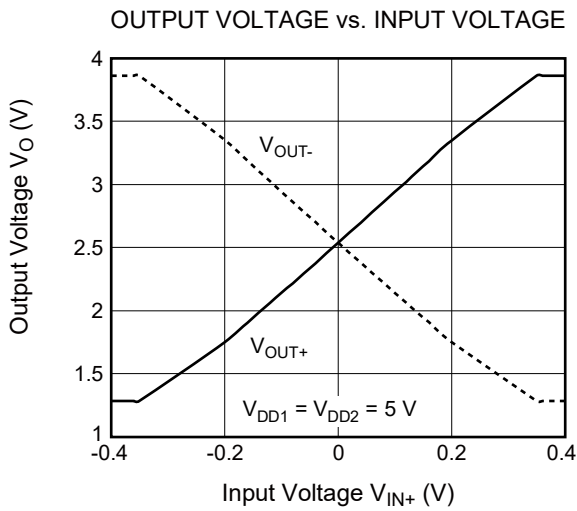

Remark The graphs indicate nominal characteristics.

SIGNAL DELAY TIME vs.
 AMBIENT TEMPERATURE

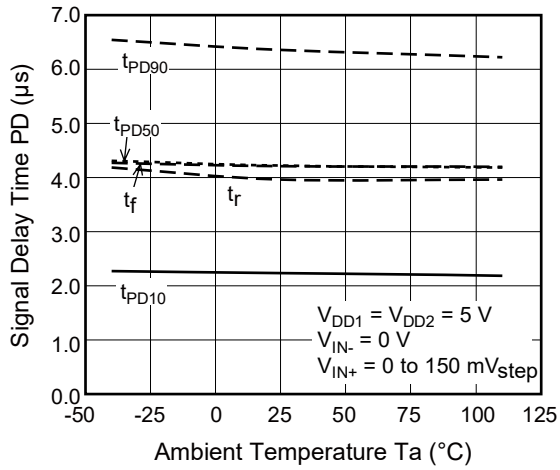

Remark The graphs indicate nominal characteristics.

TAPING SPECIFICATIONS (UNIT: mm)

Tape Direction

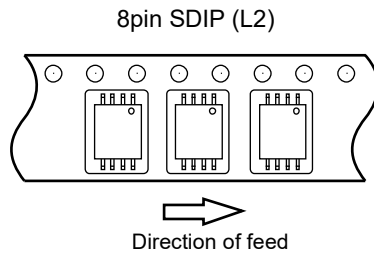

Outline and Dimensions (Tape)

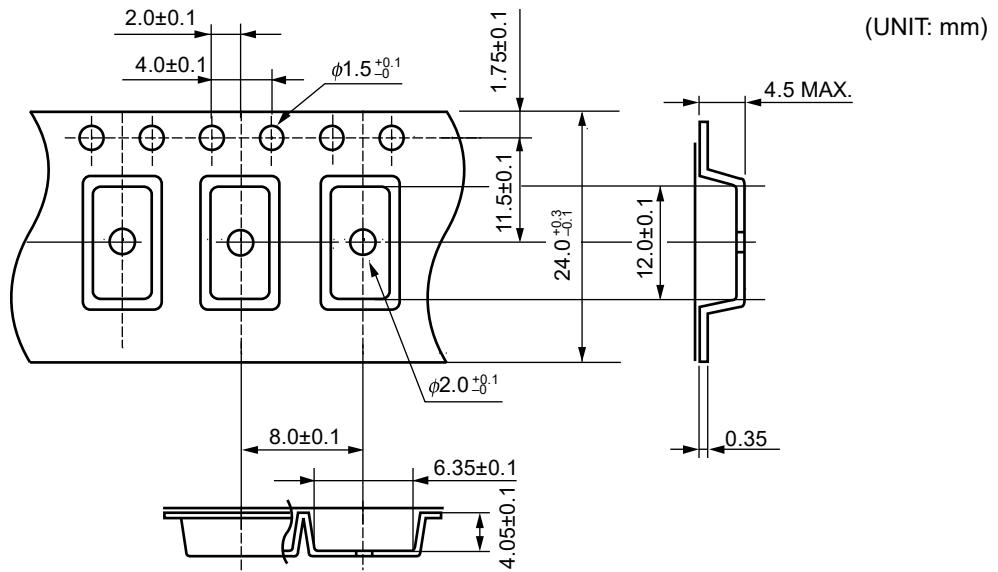

Outline and Dimensions (Reel)

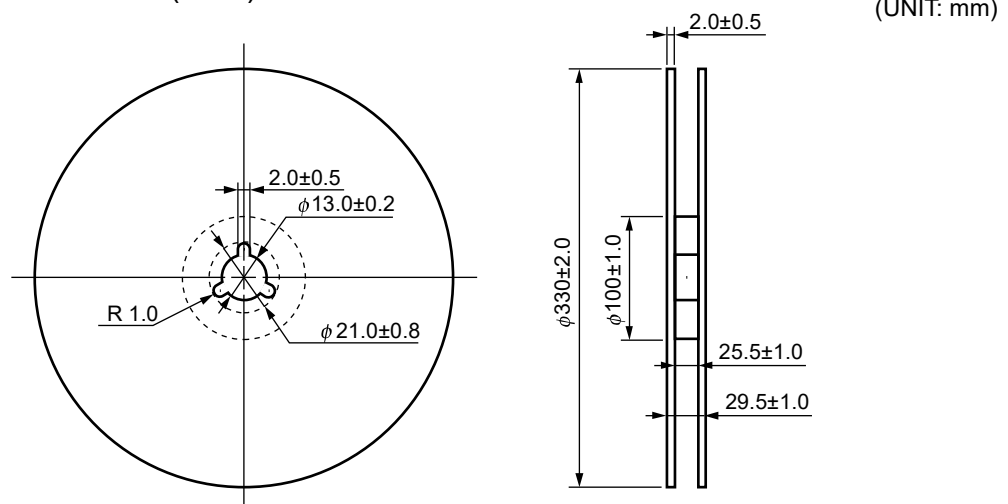

Packing: 2 000 pcs/reel

RECOMMENDED MOUNT PAD DIMENSIONS (UNIT: mm)

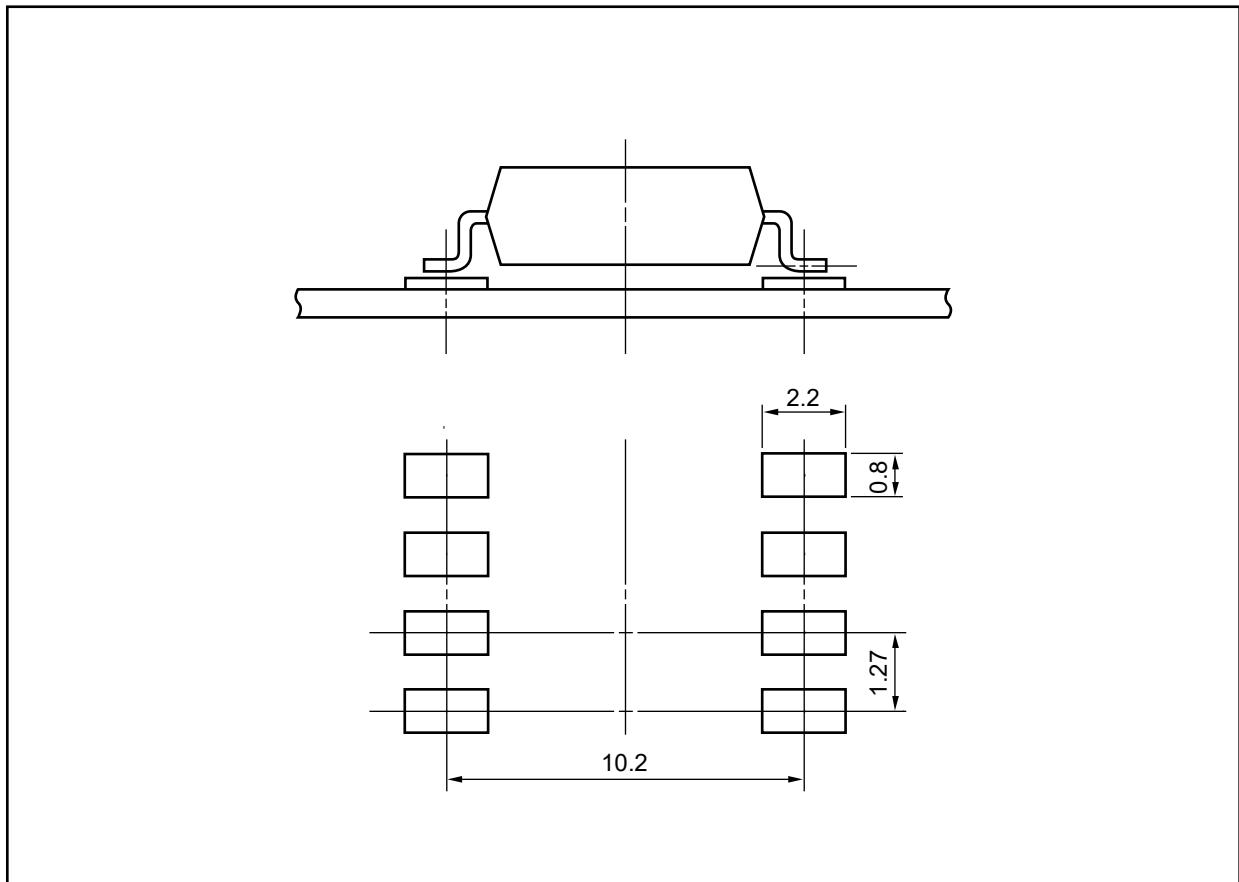

【8pin SDIP (L2)】

Remark All dimensions in this figure must be evaluated before use.

NOTES ON HANDLING

1. Recommended soldering conditions

(1) Infrared reflow soldering

- Peak reflow temperature 260 °C or below (package surface temperature)
- Time of peak reflow temperature 10 seconds or less
- Time of temperature higher than 220 °C 60 seconds or less
- Time to preheat temperature from 120 to 180 °C 120 ± 30 s
- Number of reflows Three
- Flux Rosin flux containing small amount of chlorine (The flux with a maximum chlorine content of 0.2 Wt% is recommended.)

Recommended Temperature Profile of Infrared Reflow

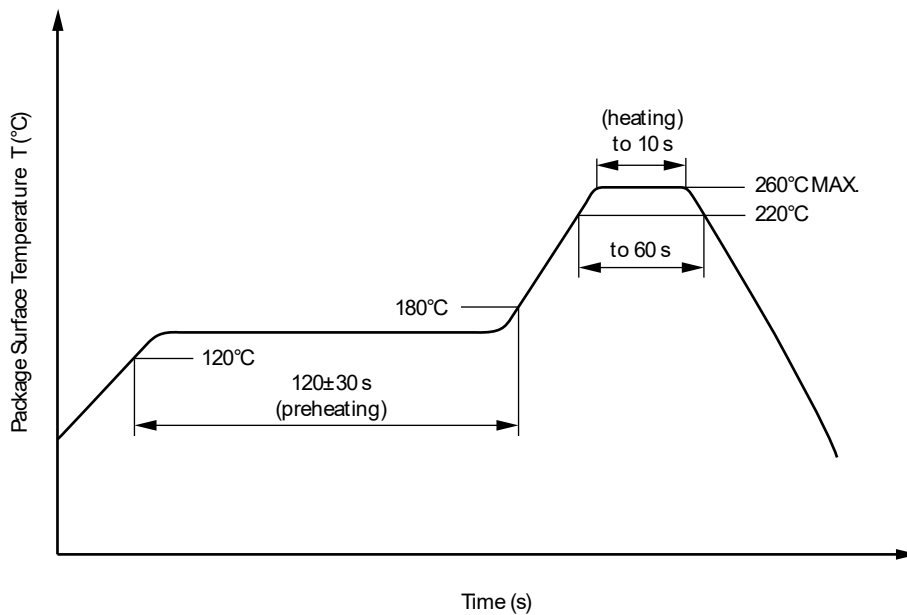

(2) Wave soldering

- Temperature 260 °C or below (molten solder temperature)
- Time 10 seconds or less
- Preheating conditions 120 °C or below (package surface temperature)
- Number of times One (Allowed to be dipped in solder including plastic mold portion.)
- Flux Rosin flux containing small amount of chlorine (The flux with a maximum chlorine content of 0.2 Wt% is recommended.)

(3) Soldering by Soldering Iron

- Peak Temperature (lead part temperature) 350 °C or below
- Time (each pins) 3 seconds or less
- Flux Rosin flux containing small amount of chlorine
(The flux with a maximum chlorine content of 0.2 Wt% is recommended.)

(a) Soldering of leads should be made at the point 1.5 to 2.0 mm from the root of the lead

(b) Please be sure that the temperature of the package would not be heated over 100°C

(4) Cautions

- Flux Cleaning
Avoid cleaning with Freon based or halogen-based (chlorinated etc.) solvents.
- Do not use fixing agents or coatings containing halogen-based substances.

2. Cautions regarding noise

Be aware that when voltage is applied suddenly between the photocoupler's input and output at startup, the output transistor may enter the on state, even if the voltage is within the absolute maximum ratings.

USAGE CAUTIONS

1. Usage cautions

- (1) This product is weak for static electricity by designed with high-speed integrated circuit so protect against static electricity when handling.
- (2) When the primary power supply (V_{DD1}) is off and only the secondary power supply (V_{DD2}) is being applied ($V_{DD1} = 0$ V and $V_{DD2} = 5$ V), V_{OUT+} outputs a low level, and V_{OUT-} outputs a high level ($V_{OUT+} = 1.3$ V TYP., $V_{OUT-} = 3.8$ V TYP.), regardless of the input voltages (V_{IN+} and V_{IN-}).
- (3) The output level of V_{OUT+} and V_{OUT-} might be unstable for several seconds immediately after the secondary power supply (V_{DD2}) is applied while the primary power supply (V_{DD1}) is being applied.

2. Board designing

- (1) By-pass capacitor of more than 0.1 μ F is used between V_{CC} and GND near device. Also, ensure that the distance between the leads of the photocoupler and capacitor is no more than 10 mm.
- (2) Keep the pattern connected the input (V_{IN+} , V_{IN-}) and the output (V_{OUT+} , V_{OUT-}), respectively, as short as possible.
- (3) Do not connect any routing to the portion of the frame exposed between the pins on the package of the photocoupler. If connected, it will affect the photocoupler's internal voltage and the photocoupler will not operate normally.
- (4) Because the maximum frequency of the signal input to the photocoupler must be lower than the allowable frequency band, be sure to connect an anti-aliasing filter (an RC filter with $R = 68 \Omega$ and $C = 0.01 \mu$ F, for example).
- (5) The signals output from the PS8352A include noise elements such as chopping noise and quantization noise generated internally. Therefore, be sure to restrict the output frequency to the required bandwidth by adding a low-pass filter function (an RC filter with $R = 10$ k Ω and $C = 150$ pF, for example) to the operational amplifier (post amplifier) in the next stage to the PS8352A.

3. Avoid storage at a high temperature and high humidity.

SPECIFICATION OF VDE MARKS LICENSE DOCUMENT

| Parameter | Symbol | Speck | Unit |
|---|--|-----------------------------|----------------------------|
| Climatic test class (IEC 60068-1/DIN EN 60068-1) | | 40/110/21 | |
| Dielectric strength maximum operating isolation voltage Test voltage (partial discharge test, procedure a for type test and random test) $U_{pr} = 1.6 \times U_{IORM}$, $P_d < 5 \text{ pC}$ | U_{IORM} U_{pr} | 1 130 1 808 | V_{peak} V_{peak} |
| Test voltage (partial discharge test, procedure b for all devices) $U_{pr} = 1.875 \times U_{IORM}$, $P_d < 5 \text{ pC}$ | U_{pr} | 2 119 | V_{peak} |
| Highest permissible overvoltage | U_{IOTM} | 8 000 | V_{peak} |
| Degree of pollution (IEC 60664-1/DIN EN 60664-1 (VDE 0110-1)) | | 2 | |
| Comparative tracking index (IEC 60112/DIN EN 60112 (VDE 0303 Part 11)) | CTI | 175 | |
| Material group (IEC 60664-1/DIN EN 60664-1 (VDE 0110-1)) | | III a | |
| Storage temperature range | T_{stg} | -55 to +125 | °C |
| Operating temperature range | T_A | -40 to +110 | °C |
| Isolation resistance, minimum value $V_{IO} = 500 \text{ V dc}$ at $T_A = 25^\circ\text{C}$ $V_{IO} = 500 \text{ V dc}$ at $T_A \text{ MAX.}$ at least 100°C | Ris MIN. Ris MIN. | 10^{12} 10^{11} | Ω Ω |
| Safety maximum ratings (maximum permissible in case of fault, see thermal derating curve) Package temperature Current (input current I_F , $\text{Psi} = 0$) Power (output or total power dissipation) Isolation resistance $V_{IO} = 500 \text{ V dc}$ at $T_A = T_{si}$ | T_{si} I_{si} Psi Ris MIN. | 175 400 700 10^9 | °C mA mW Ω |

Dependence of maximum safety ratings with package temperature

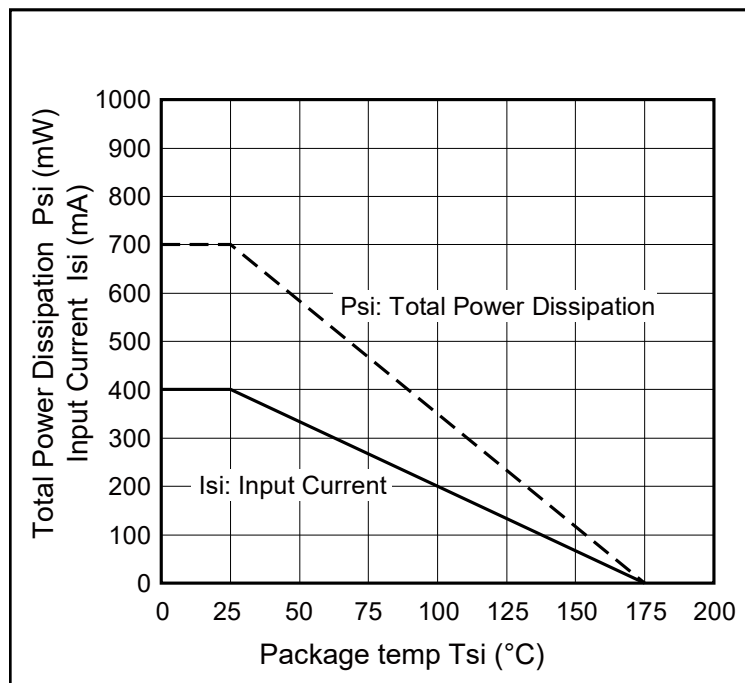

Method a Destructive Test, Type and Sample Test

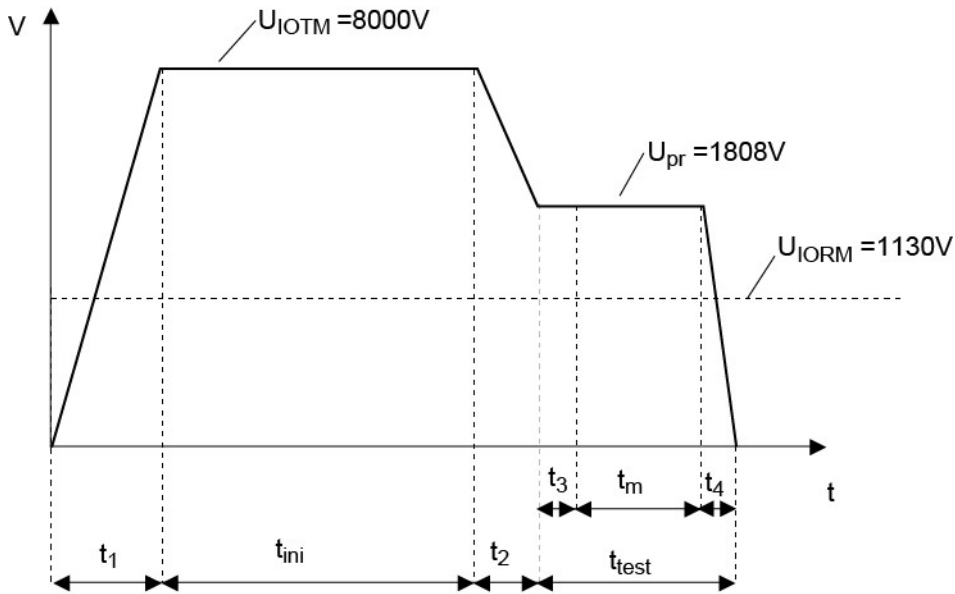

- $t_1, t_2 = 1$ to 10 sec
- $t_3, t_4 = 1$ sec
- t_m (PARTIAL DISCHARGE) = 10 sec
- $t_{test} = 12$ sec
- $t_{ini} = 60$ sec

Method b Non-destructive Test, 100% Production Test

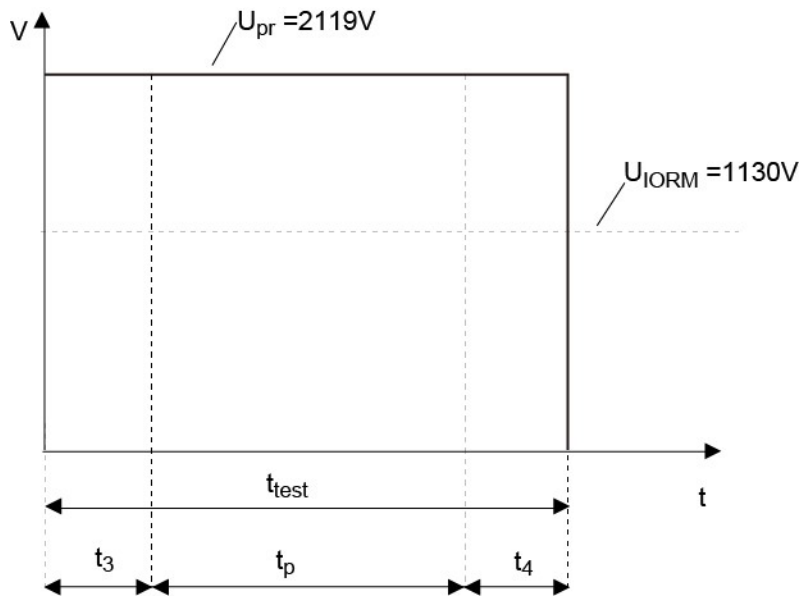

- $t_3, t_4 = 0.1$ sec
- t_m (PARTIAL DISCHARGE) = 1.0 sec
- $t_{test} = 1.2$ sec

| | | |
|----------------|---------------|--|
| Caution | GaAs Products | <p>This product uses gallium arsenide (GaAs). GaAs vapor and powder are hazardous to human health if inhaled or ingested, so please observe the following points.</p> <ul style="list-style-type: none">• Follow related laws and ordinances when disposing of the product. If there are no applicable laws and/or ordinances, dispose of the product as recommended below.<ol style="list-style-type: none">1. Commission a disposal company able to (with a license to) collect, transport and dispose of materials that contain arsenic and other such industrial waste materials.2. Exclude the product from general industrial waste and household garbage, and ensure that the product is controlled (as industrial waste subject to special control) up until final disposal.• Do not burn, destroy, cut, crush, or chemically dissolve the product.• Do not lick the product or in any way allow it to enter the mouth. |
|----------------|---------------|--|

Notice

1. Descriptions of circuits, software and other related information in this document are provided only to illustrate the operation of semiconductor products and application examples. You are fully responsible for the incorporation or any other use of the circuits, software, and information in the design of your product or system. Renesas Electronics disclaims any and all liability for any losses and damages incurred by you or third parties arising from the use of these circuits, software, or information.
2. Renesas Electronics hereby expressly disclaims any warranties against and liability for infringement or any other claims involving patents, copyrights, or other intellectual property rights of third parties, by or arising from the use of Renesas Electronics products or technical information described in this document, including but not limited to, the product data, drawings, charts, programs, algorithms, and application examples.
3. No license, express, implied or otherwise, is granted hereby under any patents, copyrights or other intellectual property rights of Renesas Electronics or others.
4. You shall be responsible for determining what licenses are required from any third parties, and obtaining such licenses for the lawful import, export, manufacture, sales, utilization, distribution or other disposal of any products incorporating Renesas Electronics products, if required.
5. You shall not alter, modify, copy, or reverse engineer any Renesas Electronics product, whether in whole or in part. Renesas Electronics disclaims any and all liability for any losses or damages incurred by you or third parties arising from such alteration, modification, copying or reverse engineering.
6. Renesas Electronics products are classified according to the following two quality grades: "Standard" and "High Quality". The intended applications for each Renesas Electronics product depends on the product's quality grade, as indicated below.

"Standard": Computers; office equipment; communications equipment; test and measurement equipment; audio and visual equipment; home electronic appliances; machine tools; personal electronic equipment; industrial robots; etc.

"High Quality": Transportation equipment (automobiles, trains, ships, etc.); traffic control (traffic lights); large-scale communication equipment; key financial terminal systems; safety control equipment; etc.

Unless expressly designated as a high reliability product or a product for harsh environments in a Renesas Electronics data sheet or other Renesas Electronics document, Renesas Electronics products are not intended or authorized for use in products or systems that may pose a direct threat to human life or bodily injury (artificial life support devices or systems; surgical implantations; etc.), or may cause serious property damage (space system; undersea repeaters; nuclear power control systems; aircraft control systems; key plant systems; military equipment; etc.). Renesas Electronics disclaims any and all liability for any damages or losses incurred by you or any third parties arising from the use of any Renesas Electronics product that is inconsistent with any Renesas Electronics data sheet, user's manual or other Renesas Electronics document.
7. No semiconductor product is absolutely secure. Notwithstanding any security measures or features that may be implemented in Renesas Electronics hardware or software products, Renesas Electronics shall have absolutely no liability arising out of any vulnerability or security breach, including but not limited to any unauthorized access to or use of a Renesas Electronics product or a system that uses a Renesas Electronics product. RENESAS ELECTRONICS DOES NOT WARRANT OR GUARANTEE THAT RENESAS ELECTRONICS PRODUCTS, OR ANY SYSTEMS CREATED USING RENESAS ELECTRONICS PRODUCTS WILL BE INVULNERABLE OR FREE FROM CORRUPTION, ATTACK, VIRUSES, INTERFERENCE, HACKING, DATA LOSS OR THEFT, OR OTHER SECURITY INTRUSION ("Vulnerability Issues"). RENESAS ELECTRONICS DISCLAIMS ANY AND ALL RESPONSIBILITY OR LIABILITY ARISING FROM OR RELATED TO ANY VULNERABILITY ISSUES. FURTHERMORE, TO THE EXTENT PERMITTED BY APPLICABLE LAW, RENESAS ELECTRONICS DISCLAIMS ANY AND ALL WARRANTIES, EXPRESS OR IMPLIED, WITH RESPECT TO THIS DOCUMENT AND ANY RELATED OR ACCOMPANYING SOFTWARE OR HARDWARE, INCLUDING BUT NOT LIMITED TO THE IMPLIED WARRANTIES OF MERCHANTABILITY, OR FITNESS FOR A PARTICULAR PURPOSE.
8. When using Renesas Electronics products, refer to the latest product information (data sheets, user's manuals, application notes, "General Notes for Handling and Using Semiconductor Devices" in the reliability handbook, etc.), and ensure that usage conditions are within the ranges specified by Renesas Electronics with respect to maximum ratings, operating power supply voltage range, heat dissipation characteristics, installation, etc. Renesas Electronics disclaims any and all liability for any malfunctions, failure or accident arising out of the use of Renesas Electronics products outside of such specified ranges.
9. Although Renesas Electronics endeavors to improve the quality and reliability of Renesas Electronics products, semiconductor products have specific characteristics, such as the occurrence of failure at a certain rate and malfunctions under certain use conditions. Unless designated as a high reliability product or a product for harsh environments in a Renesas Electronics data sheet or other Renesas Electronics document, Renesas Electronics products are not subject to radiation resistance design. You are responsible for implementing safety measures to guard against the possibility of bodily injury, injury or damage caused by fire, and/or danger to the public in the event of a failure or malfunction of Renesas Electronics products, such as safety design for hardware and software, including but not limited to redundancy, fire control and malfunction prevention, appropriate treatment for aging degradation or any other appropriate measures. Because the evaluation of microcomputer software alone is very difficult and impractical, you are responsible for evaluating the safety of the final products or systems manufactured by you.
10. Please contact a Renesas Electronics sales office for details as to environmental matters such as the environmental compatibility of each Renesas Electronics product. You are responsible for carefully and sufficiently investigating applicable laws and regulations that regulate the inclusion or use of controlled substances, including without limitation, the EU RoHS Directive, and using Renesas Electronics products in compliance with all these applicable laws and regulations. Renesas Electronics disclaims any and all liability for damages or losses occurring as a result of your noncompliance with applicable laws and regulations.
11. Renesas Electronics products and technologies shall not be used for or incorporated into any products or systems whose manufacture, use, or sale is prohibited under any applicable domestic or foreign laws or regulations. You shall comply with any applicable export control laws and regulations promulgated and administered by the governments of any countries asserting jurisdiction over the parties or transactions.
12. It is the responsibility of the buyer or distributor of Renesas Electronics products, or any other party who distributes, disposes of, or otherwise sells or transfers the product to a third party, to notify such third party in advance of the contents and conditions set forth in this document.
13. This document shall not be reprinted, reproduced or duplicated in any form, in whole or in part, without prior written consent of Renesas Electronics.
14. Please contact a Renesas Electronics sales office if you have any questions regarding the information contained in this document or Renesas Electronics products.

(Note1) "Renesas Electronics" as used in this document means Renesas Electronics Corporation and also includes its directly or indirectly controlled subsidiaries.

(Note2) "Renesas Electronics product(s)" means any product developed or manufactured by or for Renesas Electronics.

(Rev.5.0-1 October 2020)

Corporate Headquarters

TOYOSU FORESIA, 3-2-24 Toyosu,
Koto-ku, Tokyo 135-0061, Japan
www.renesas.com

Trademarks



Renesas and the Renesas logo are trademarks of Renesas Electronics Corporation. All trademarks and registered trademarks are the property of their respective owners.

Contact information

For further information on a product, technology, the most up-to-date version of a document, or your nearest sales office, please visit:
www.renesas.com/contact/.

Looking for pricing, stock, or lifecycle information?

Click below to explore more details on WIN SOURCE:

-  [View PS8352AL2-V-E3-AX on WIN SOURCE](#)
-  [Renesas Electronics America Information](#)

Optimize Your Supply Chain with WIN SOURCE Solutions

-  Global Sourcing Solution
-  Obsolete Management
-  Cost Control Management
-  Shortage Management
-  Alternative Solution
-  Excess Inventory Management