



**THE DATASHEET OF
ADM2795ETR WZ-EP**



FEATURES

- 5 kV rms isolated RS-485 transceiver
- ± 42 V ac/dc peak fault protection on RS-485 bus pins
- DO-160G Section 25 ESD protection: ± 15 kV air discharge
- Fully certified DO-160G EMC protection on RS-485 bus pins
 - Section 22 lightning protection Waveform 3, Waveform 4/ Waveform 1, Waveform 5A Pin injection, Level 4 protection
- RS-485 A, B pins HBM ESD protection: $> \pm 30$ kV
- Safety and regulatory approvals
 - CSA Component Acceptance Notice 5A, DIN V VDE V 0884-10, UL 1577, CQC11-471543-2012 (pending)
- TIA/EIA RS-485/RS-422 compliant over full supply range
 - 3 V to 5.5 V operating voltage range on V_{DD2}
 - 1.7 V to 5.5 V operating voltage range on V_{DD1} logic supply
- Common-mode input range of -25 V to $+25$ V
- High common-mode transient immunity: > 75 kV/ μ s
- Robust noise immunity (tested to the IEC 62132-4 standard)
- Passes EN55022 Class B radiated emissions by 6 dB μ V/m margin
- Receiver short-circuit, open-circuit, and floating input fail-safe
- Supports 256 bus nodes (96 k Ω receiver input impedance)
- Glitch free power-up/power-down (hot swap)

ENHANCED PRODUCT FEATURES

- Supports defense and aerospace applications (AQEC standard)
- Military -55°C to $+125^{\circ}\text{C}$ temperature range
- Controlled manufacturing baseline
- 1 assembly/test site
- Enhanced product change notification
- Qualification data available on request

APPLICATIONS

Military and aerospace (MILA) avionics for sensors, actuators, and engine control

GENERAL DESCRIPTION

The ADM2795E-EP is a 5 kV rms signal isolated RS-485 transceiver that features up to ± 42 V of ac/dc peak bus overvoltage fault protection on the RS-485 bus pins. The device integrates Analog Devices, Inc., *iCoupler*[®] technology to combine a 3-channel isolator, RS-485 transceiver, and IEC electromagnetic compatibility (EMC) transient protection in a single package. The ADM2795E-EP integrates fully certified DO-160G EMC protection on the RS-485 bus pins, with Section 22 lightning protection. The ADM2795E-EP also provides Section 25 ± 15 kV ESD air discharge protection. For Section 22 lightning, the ADM2795E-EP provides protection for Waveform 3, Waveform 4/ Waveform 1, and Waveform 5A to Level 4 using 33 Ω or 47 Ω current limiting resistors to GND_2 , or to Level 4 across the isolation barrier to GND_1 . This device has an extended common-mode input range of ± 25 V to improve data communication reliability in noisy environments. The ADM2795E-EP is capable of operating over wide power supply ranges, with a 1.7 V to 5.5 V V_{DD1} power supply range, allowing interfacing to low voltage logic supplies. The ADM2795E-EP is also fully TIA/EIA RS-485/RS-422 compliant when operated over a 3 V to 5.5 V V_{DD2} power supply. The device is fully characterized over an extended operating temperature range of -55°C to $+125^{\circ}\text{C}$, and is available in a 16-lead, wide-body SOIC package.

Additional application and technical information can be found in the [ADM2795E](#) data sheet.

FUNCTIONAL BLOCK DIAGRAM

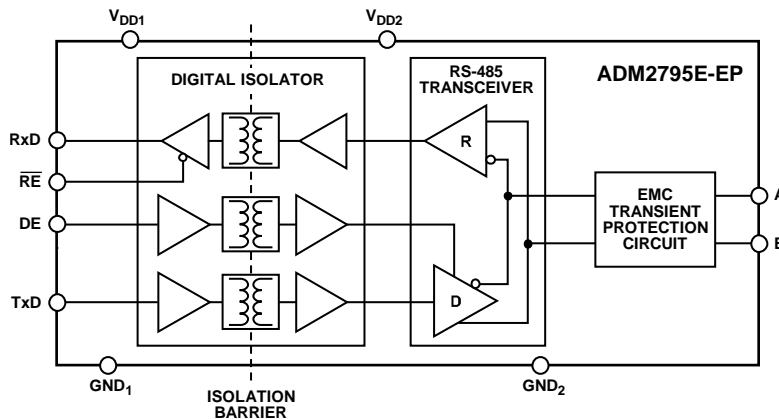

Figure 1.

Rev. 0

[Document Feedback](#)

Information furnished by Analog Devices is believed to be accurate and reliable. However, no responsibility is assumed by Analog Devices for its use, nor for any infringements of patents or other rights of third parties that may result from its use. Specifications subject to change without notice. No license is granted by implication or otherwise under any patent or patent rights of Analog Devices. Trademarks and registered trademarks are the property of their respective owners.

TABLE OF CONTENTS

Features	1	Absolute Maximum Ratings	7
Enhanced Product Features	1	Thermal Resistance	7
Applications	1	ESD Caution.....	7
General Description	1	Pin Configuration and Function Descriptions.....	8
Functional Block Diagram	1	Typical Performance Characteristics	9
Revision History	2	Test Circuits.....	13
Specifications.....	3	Switching Characteristics	14
Timing Specifications	4	Theory of Operation	15
Insulation and Safety Related Specifications	5	RS-485 with Added DO-160G EMC Robustness	15
Package Characteristics	5	Certified DO-160G EMC Protection	15
Regulatory Information.....	5	DO-160G ADM2795E-EP Test Details.....	15
DIN V VDE V 0884-10 (VDE V 0884-10) Insulation		Outline Dimensions	17
Characteristics	6	Ordering Guide	17

REVISION HISTORY

7/2017—Revision 0: Initial Version

SPECIFICATIONS

1.7 V ≤ V_{DD1} ≤ 5.5 V, 3 V ≤ V_{DD2} ≤ 5.5 V, T_A = -55°C to +125°C. All min/max specifications apply over the entire recommended operation range, unless otherwise noted. All typical specifications at T_A = 25°C, V_{DD1} = V_{DD2} = 5.0 V, unless otherwise noted.

Table 1.

Parameter	Symbol	Min	Typ	Max	Unit	Test Conditions/Comments
SUPPLY CURRENT						
Power Supply Current						
Logic Side	I _{DD1}			10	mA	Unloaded output, DE = V _{DD1} , $\overline{RE} = 0$ V
TxD/RxD Data Rate = 2.5 Mbps				10	mA	Unloaded output, DE = V _{DD1} , $\overline{RE} = 0$ V
Bus Side	I _{DD2}			12	mA	Unloaded output, DE = V _{DD1} , $\overline{RE} = 0$ V
TxD/RxD Data Rate = 2.5 Mbps				90	mA	Unloaded output, DE = V _{DD1} , $\overline{RE} = 0$ V
				130	mA	DE = V _{DD1} , $\overline{RE} = 0$ V, V _{DD2} = 5.5 V, R = 27 Ω, see Figure 27
			94		mA	DE = V _{DD1} , $\overline{RE} = 0$ V, V _{DD2} = 5.5 V, R = 27 Ω, see Figure 27
			46		mA	DE = V _{DD1} , $\overline{RE} = 0$ V, V _{DD2} = 3.0 V, R = 27 Ω, see Figure 27
Supply Current in Shutdown Mode	I _{SHDN}			10	mA	DE = 0 V, $\overline{RE} = V_{DD1}$
DRIVER						
Differential Outputs						
Differential Output Voltage	V _{OD}	1.5		5.0	V	V _{DD2} ≥ 3.0 V, R = 27 Ω or 50 Ω, see Figure 27
		2.1		5.0	V	V _{DD2} ≥ 4.5 V, R = 27 Ω or 50 Ω, see Figure 27
	V _{OD3}	1.5		5.0	V	V _{DD2} ≥ 3.0 V, V _{CM} = -25 V to +25 V, see Figure 28
		2.1		5.0	V	V _{DD2} ≥ 4.5 V, V _{CM} = -25 V to +25 V, see Figure 28
Change in Differential Output Voltage for Complementary Output States	Δ V _{OD}			0.2	V	R = 27 Ω or 50 Ω, see Figure 27
Common-Mode Output Voltage	V _{OC}			3.0	V	R = 27 Ω or 50 Ω, see Figure 27
Change in Common-Mode Output Voltage for Complementary Output States	Δ V _{OC}			0.2	V	R = 27 Ω or 50 Ω, see Figure 27
Short-Circuit Output Current						
V _{OUT} = Low	I _{OSL}	-250		+250	mA	-42 V ≤ V _{SC} ≤ +42 V ¹
V _{OUT} = High	I _{OSH}	-250		+250	mA	-42 V ≤ V _{SC} ≤ +42 V ¹
Logic Inputs (DE, \overline{RE} , TxD)						
Input Threshold Low	V _{IL}			0.33 × V _{DD1}	V	1.7 V ≤ V _{DD1} ≤ 5.5 V
Input Threshold High	V _{IH}	0.7 V _{DD1}			V	1.7 V ≤ V _{DD1} ≤ 5.5 V
Input Current	I _{TxD}			+1	μA	0 V ≤ V _{IN} ≤ V _{DD1}
RECEIVER						
Differential Inputs						
Differential Input Threshold Voltage	V _{TH}	-200	-125	-30	mV	-25 V ≤ V _{CM} ≤ +25 V
Input Voltage Hysteresis	V _{HYS}		30		mV	-25 V ≤ V _{CM} ≤ +25 V
Input Current (A, B)	I _I	-1.0		+1.0	mA	DE = 0 V, V _{DD2} = 0 V/5 V, V _{IN} = ±25 V
		-1.0		+1.0	mA	DE = 0 V, V _{DD2} = 0 V/5 V, V _{IN} = ±42 V
Input Capacitance (A, B)	C _{AB}		150		pF	T _A = 25°C, see Figure 17
Line Input Resistance	R _{IN}	96			kΩ	-25 V ≤ V _{CM} ≤ +25 V, up to 256 nodes supported

Parameter	Symbol	Min	Typ	Max	Unit	Test Conditions/Comments
Logic Outputs						
Output Voltage Low	V_{OLRXD}			0.2	V	$I_{ORxD} = 3.0 \text{ mA}$, $V_A - V_B = -0.2 \text{ V}$
Output Voltage High	V_{OHRxD}	$V_{DD1} - 0.2$			V	$I_{ORxD} = -3.0 \text{ mA}$, $V_A - V_B = 0.2 \text{ V}$
Short-Circuit Current				100	mA	$V_{OUT} = \text{GND or } V_{DD1}$, $\overline{RE} = 0 \text{ V}$
Three-State Output Leakage Current	I_{OZR}			± 2	μA	$\overline{RE} = V_{DD1}$, $RxD = 0 \text{ V or } V_{DD1}$
COMMON-MODE TRANSIENT IMMUNITY ²		75	125		kV/ μs	$V_{CM} \geq 1 \text{ kV}$, transient magnitude $\geq 800 \text{ V}$

¹ V_{SC} is the short-circuit voltage at the RS-485 A or B bus pin.

² Common-mode transient immunity is the maximum common-mode voltage slew rate that can be sustained while maintaining specification compliant operation. V_{CM} is the common-mode potential difference between the logic and bus sides. The transient magnitude is the range over which the common mode is slewed. The common-mode voltage slew rates apply to both rising and falling common-mode voltage edges.

TIMING SPECIFICATIONS

$V_{DD1} = 1.7 \text{ V to } 5.5 \text{ V}$, $V_{DD2} = 3.0 \text{ V to } 5.5 \text{ V}$, $T_A = T_{MIN}$ to T_{MAX} (-55°C to $+125^\circ\text{C}$), unless otherwise noted.

Table 2.

Parameter	Min	Typ	Max	Unit	Test Conditions/Comments
DRIVER ¹					
Maximum Data Rate	2.5			Mbps	
Propagation Delay, t_{DPLH} , t_{DPHL}		30	500	ns	$R_{L\text{DIFF}} = 54 \Omega$, $C_{L1} = C_{L2} = 100 \text{ pF}$, see Figure 29 and Figure 33
Differential Skew, t_{SKEW}		10	50	ns	$R_{L\text{DIFF}} = 54 \Omega$, $C_{L1} = C_{L2} = 100 \text{ pF}$, see Figure 29 and Figure 33
Rise/Fall Times, t_R , t_F		40	130	ns	$R_{L\text{DIFF}} = 54 \Omega$, $C_{L1} = C_{L2} = 100 \text{ pF}$, see Figure 29 and Figure 33
Enable Time, t_{ZH} , t_{ZL}		500	2500	ns	$R_L = 110 \Omega$, $C_L = 50 \text{ pF}$, see Figure 30 and Figure 35
Disable Time, t_{HZ} , t_{LZ}		500	2500	ns	$R_L = 110 \Omega$, $C_L = 50 \text{ pF}$, see Figure 30 and Figure 35
RECEIVER ²					
Propagation Delay, t_{PLH} , t_{PHL}		120	200	ns	$C_L = 15 \text{ pF}$, see Figure 31 and Figure 34, $10, V_{ID} \geq \pm 1.5 \text{ V}$
		140	220	ns	$C_L = 15 \text{ pF}$, see Figure 31 and Figure 34, $V_{ID} \geq \pm 600 \text{ mV}$
Skew, t_{SKEW}		4	40	ns	$C_L = 15 \text{ pF}$, see Figure 31 and Figure 34, $V_{ID} \geq \pm 1.5 \text{ V}$
Enable Time		10	50	ns	$R_L = 1 \text{ k}\Omega$, $C_L = 15 \text{ pF}$, see Figure 32 and Figure 36
Disable Time		10	50	ns	$R_L = 1 \text{ k}\Omega$, $C_L = 15 \text{ pF}$, see Figure 32 and Figure 36
RxD Pulse Width Distortion			40	ns	$C_L = 15 \text{ pF}$, see Figure 31 and Figure 34, $V_{ID} \geq \pm 1.5 \text{ V}$

¹ See Figure 29 for the definition of $R_{L\text{DIFF}}$.

² Receiver propagation delay, skew, and pulse width distortion specifications are tested with a receiver differential input voltage (V_{ID}) of $\geq \pm 600 \text{ mV}$ or $\geq \pm 1.5 \text{ V}$, as noted.

INSULATION AND SAFETY RELATED SPECIFICATIONS

For additional information, see www.analog.com/icouplersafety.

Table 3.

Parameter	Symbol	Value	Unit	Conditions
Rated Dielectric Insulation Voltage		5000	V rms	1 minute duration
Minimum External Air Gap (Clearance)	L(I01)	7.8	mm min	Measured from input terminals to output terminals, shortest distance through air
Minimum External Tracking (Creepage)	L(I02)	7.8	mm min	Measured from input terminals to output terminals, shortest distance along body
Minimum Clearance in the Plane of the Printed Circuit Board (PCB Clearance)	L(PCB)	8.3	mm min	Measured from input terminals to output terminals, shortest distance through air, line of sight, in the PCB mounting plane
Minimum Internal Gap (Internal Clearance)		25.5	µm min	Minimum distance through insulation
Tracking Resistance (Comparative Tracking Index)	CTI	>400	V	DIN IEC 112/VDE 0303 Part 1
Material Group		II		Material Group (DIN VDE 0110, 1/89)

PACKAGE CHARACTERISTICS**Table 4.**

Parameter	Symbol	Min	Typ	Max	Unit	Test Conditions/Comments
Resistance (Input to Output) ¹	R _{I-O}		10 ¹³		Ω	
Capacitance (Input to Output) ¹	C _{I-O}		2.2		pF	f = 1 MHz
Input Capacitance ²	C _I		4.0		pF	
Input Capacitance, A and B Pins	C _{AB}		150		pF	T _A = 25°C, see Figure 17
IC Junction to Ambient Thermal Resistance	θ _{JA}		59.7		°C/W	Thermocouple located at center of package underside

¹ The device is considered a 2-terminal device: Pin 1 through Pin 8 are shorted together, and Pin 9 through Pin 16 are shorted together.

² Input capacitance is from any digital input pin to ground.

REGULATORY INFORMATION

See Table 8 and the ADM2795E data sheet for details regarding recommended maximum working voltages for specific cross isolation waveforms and insulation levels.

The ADM2795E-EP is approved or pending approval by the organizations listed in Table 5.

Table 5. ADM2795E-EP Approvals

UL	CSA	VDE	CQC (Pending)
Recognized Under UL 1577 Component Recognition Program ¹	Approved under CSA Component Acceptance Notice 5A	Certified according to DIN V VDE V 0884-10 (VDE V 0884-10):2006-12 ²	Certified by CQC11-471543-2012, GB4943.1-2011
Single Protection, 5000 V rms Isolation Voltage	CSA 60950-1-07+A1+A2 and IEC 60950-1 second edition +A1+A2: Basic insulation at 780 V rms (1103 V peak) Reinforced insulation at 390 V rms (552 V peak) IEC 60601-1 Edition 3.1: basic insulation (two means of patient protection (MOPP)), 250 V rms (353 V peak) CSA 61010-1-12 and IEC 61010-1 third edition: Basic insulation at 300 V rms mains, 780 V secondary (1103 V peak) Reinforced insulation at 300 V rms mains, 390 V secondary (552 V peak)	Reinforced insulation, V _{IORM} = 849 V peak, V _{IOSM} = 8000 V peak	Basic insulation at 780 V rms (1103 V peak) Reinforced insulation at 389 V rms (552 V peak)
File E214100	File 70078455	File 40011599	File (pending)

¹ In accordance with UL 1577, each ADM2795E-EP is proof tested by applying an insulation test voltage ≥ 6000 V rms for 1 sec.

² In accordance with DIN V VDE V 0884-10, each ADM2795E-EP is proof tested by applying an insulation test voltage ≥ 1592 V peak for 1 sec.

DIN V VDE V 0884-10 (VDE V 0884-10) INSULATION CHARACTERISTICS

This isolator is suitable for reinforced electrical isolation only within the safety limit data. Maintenance of the safety data must be ensured by means of protective circuits.

An asterisk (*) on a package denotes VDE 0884 approval for a 849 V peak working voltage.

Table 6.

Description	Test Conditions/Comments	Symbol	Characteristic	Unit
Installation Classification per DIN VDE 0110 for Rated Mains Voltage			I to IV	
≤150 V rms			I to IV	
≤300 V rms			I to III	
≤400 V rms			40/125/21	
Climatic Classification			2	
Pollution Degree (DIN VDE 0110, see Table 3)			849	V peak
Maximum Working Insulation Voltage		V_{IORM}	1592	V peak
Input to Output Test Voltage, Method b1	$V_{IORM} \times 1.875 = V_{PR}$, 100% production tested, $t_m = 1$ sec, partial discharge < 5 pC	V_{PR}		
Input to Output Test Voltage, Method a		V_{PR}		
After Environmental Tests, Subgroup 1	$V_{IORM} \times 1.5 = V_{PR}$, $t_m = 60$ sec, partial discharge < 5 pC		1274	V peak
After Input and/or Safety Test, Subgroup 2/Subgroup 3	$V_{IORM} \times 1.2 = V_{PR}$, $t_m = 60$ sec, partial discharge < 5 pC		1019	V peak
Highest Allowable Overvoltage	Transient overvoltage, $t_{TR} = 10$ sec	V_{IOTM}	7000	V peak
Reinforced Surge Isolation Voltage	$V_{PEAK} = 12.8$ kV, 1.2 μ s rise time, 50 μ s, 50% fall time	V_{IOSM}	8000	V peak
Safety Limiting Values	Maximum value allowed in the event of a failure, see Figure 2	T_S	150	°C
Total Power Dissipation at $T_A = 25^\circ\text{C}$		P_S	1.80	W
Insulation Resistance at T_S	$V_{IO} = 500$ V	R_S	>10 ⁹	Ω

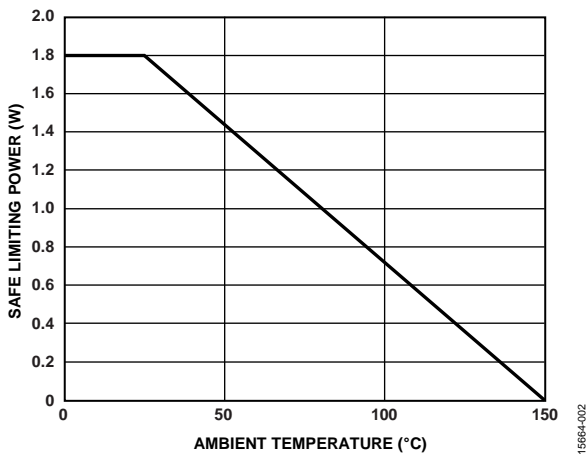

Figure 2. Thermal Derating Curve for RW-16 Wide Body [SOIC_W] Package, Dependence of Safety Limiting Values with Ambient Temperature per DIN V VDE V 0884-10

ABSOLUTE MAXIMUM RATINGS

T_A = 25°C, unless otherwise noted.

Table 7.

Parameter	Rating
V _{DD1}	−0.5 V to +7 V
V _{DD2}	−0.5 V to +7 V
Digital Input/Output Voltage (DE, \overline{RE} , TxD, RxD)	−0.3 V to V _{DD1} + 0.3 V
Driver Output/Receiver Input Voltage	±48 V
Operating Temperature Range	−55°C to +125°C
Storage Temperature Range	−65°C to +150°C
Maximum Junction Temperature	150°C
Continuous Total Power Dissipation	405 mW
Lead Temperature	
Soldering (10 sec)	300°C
Vapor Phase (60 sec)	215°C
Infrared (15 sec)	220°C
ESD (A, B Pins Tested to GND ₂)	
IEC 61000-4-2 Contact Discharge	±8 kV
IEC 62000-4-2 Air Discharge	±15 kV
EFT (A, B Pins Tested to GND ₂)	
IEC 61000-4-4 Level 4 EFT Protection	±2 kV
Surge (A, B Pins Tested to GND ₂)	
IEC 61000-4-5 Level 4 Surge Protection	±4 kV
EMC Performance from A, B Bus Pins Across the Isolation Barrier to GND ₁	
ESD	
IEC 61000-4-2 Contact Discharge	±9 kV
IEC 61000-4-2 Air Discharge	±8 kV
EFT	
IEC 61000-4-4	±2 kV
Surge	
IEC 61000-4-5	±4 kV
Human Body Model (HBM) ESD Protection (A, B Pins Tested to GND ₂)	>±30 kV
HBM ESD Protection (All Pins)	±6 kV
DO-160G Section 25 ESD Protection Air Discharge	±15 kV
Field Induced Charged Device Model ESD (FICDM)	±1.25 kV

Stresses at or above those listed under Absolute Maximum Ratings may cause permanent damage to the product. This is a stress rating only; functional operation of the product at these or any other conditions above those indicated in the operational section of this specification is not implied. Operation beyond the maximum operating conditions for extended periods may affect product reliability.

Table 8. Maximum Continuous Working Voltage¹

Parameter	Max	Unit	Reference Standard ²
AC Voltage			
Bipolar Waveform			
Basic Insulation	849	V peak	50-year minimum insulation lifetime
Reinforced Insulation	768	V peak	Lifetime limited by package creepage maximum approved working voltage per IEC 60950-1
Unipolar Waveform			
Basic Insulation	1698	V peak	50-year minimum insulation lifetime
Reinforced Insulation	885	V peak	Lifetime limited by package creepage maximum approved working voltage per IEC 60950-1
DC Voltage			
Basic Insulation	1092	V peak	Lifetime limited by package creepage maximum approved working voltage per IEC 60950-1
Reinforced Insulation	543	V peak	Lifetime limited by package creepage maximum approved working voltage per IEC 60950-1

¹ The maximum continuous working voltage refers to the continuous voltage magnitude imposed across the isolation barrier. See the ADM2795E data sheet for more details.

² Insulation lifetime for the specified test condition is greater than 50 years.

THERMAL RESISTANCE

Thermal performance is directly linked to PCB design and operating environment. Careful attention to PCB thermal design is required.

θ_{JA} is the natural convection junction to ambient thermal resistance measured in a one cubic foot sealed enclosure. θ_{JC} is the junction to case thermal resistance.

Table 9. Thermal Resistance

Package Type	θ_{JA} ¹	θ_{JC} ¹	Unit
RW-16	59.7	28.3	°C/W

¹ Thermal impedance simulated values are based on a JEDEC 252P thermal test board with no vias. See JEDEC JESD51.

ESD CAUTION



ESD (electrostatic discharge) sensitive device. Charged devices and circuit boards can discharge without detection. Although this product features patented or proprietary protection circuitry, damage may occur on devices subjected to high energy ESD. Therefore, proper ESD precautions should be taken to avoid performance degradation or loss of functionality.

PIN CONFIGURATION AND FUNCTION DESCRIPTIONS

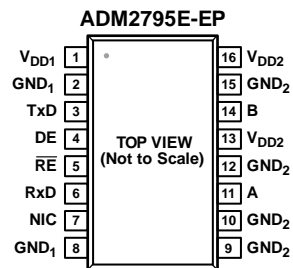

NOTES
1. NIC = NOT INTERNALLY CONNECTED.

15864-003

Figure 3. Pin Configuration

Table 10. Pin Function Descriptions

Pin No.	Mnemonic	Description
1	V _{DD1}	1.7 V to 5.5 V Flexible Logic Interface Supply.
2	GND ₁	Ground 1, Logic Side.
3	TxD	Transmit Data Input. Data to be transmitted by the driver is applied to this input.
4	DE	Driver Output Enable. A high level on this pin enables the driver differential outputs, A and B. A low level places them into a high impedance state.
5	RE	Receiver Enable Input. This pin is an active low input. Driving this input low enables the receiver, and driving it high disables the receiver.
6	RxD	Receiver Output Data. This output is high when $(A - B) > -30$ mV and low when $(A - B) < -200$ mV.
7	NIC	Not Internally Connected. This pin is not internally connected.
8	GND ₁	Ground 1, Logic Side.
9	GND ₂	Isolated Ground 2, Bus Side.
10	GND ₂	Isolated Ground 2, Bus Side.
11	A	Noninverting Driver Output/Receiver Input. When the driver is disabled, or when V _{DD1} or V _{DD2} is powered down, Pin A is put into a high impedance state to avoid overloading the bus.
12	GND ₂	Isolated Ground 2, Bus Side.
13	V _{DD2}	3 V to 5.5 V Power Supply. Pin 13 must be connected externally to Pin 16.
14	B	Inverting Driver Output/Receiver Input. When the driver is disabled, or when V _{DD1} or V _{DD2} is powered down, Pin B is put into a high impedance state to avoid overloading the bus.
15	GND ₂	Isolated Ground 2, Bus Side.
16	V _{DD2}	3 V to 5.5 V Power Supply. Pin 16 must be connected externally to Pin 13.

TYPICAL PERFORMANCE CHARACTERISTICS

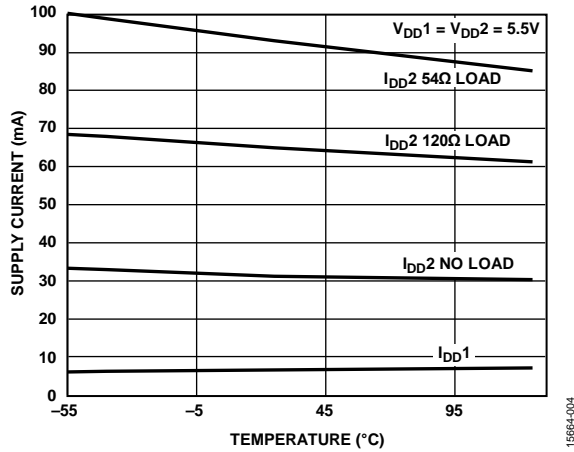

Figure 4. Supply Current (I_{CC}) vs. Temperature at $R_L = 54 \Omega$, 120Ω , and No Load; Data Rate = 2.5 Mbps, $V_{DD1} = 5.5 \text{ V}$, $V_{DD2} = 5.5 \text{ V}$

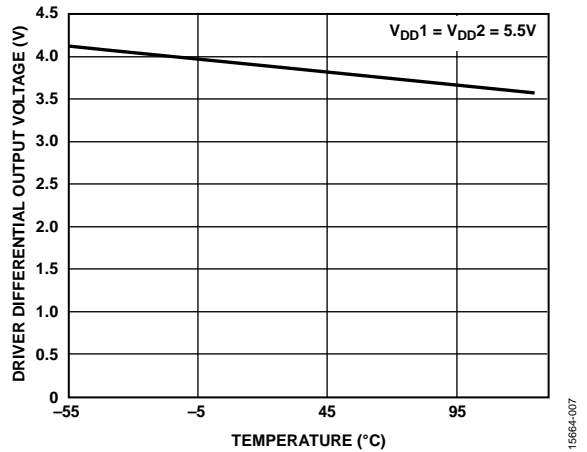

Figure 7. Driver Differential Output Voltage vs. Temperature

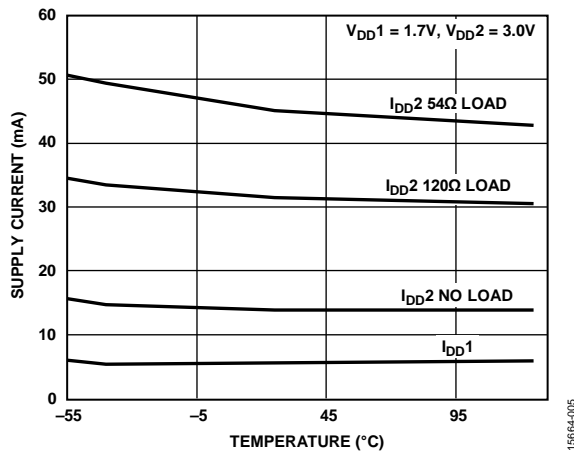

Figure 5. Supply Current (I_{CC}) vs. Temperature at $R_L = 54 \Omega$, 120Ω , and No Load; Data Rate = 2.5 Mbps, $V_{DD1} = 1.7 \text{ V}$, $V_{DD2} = 3.0 \text{ V}$

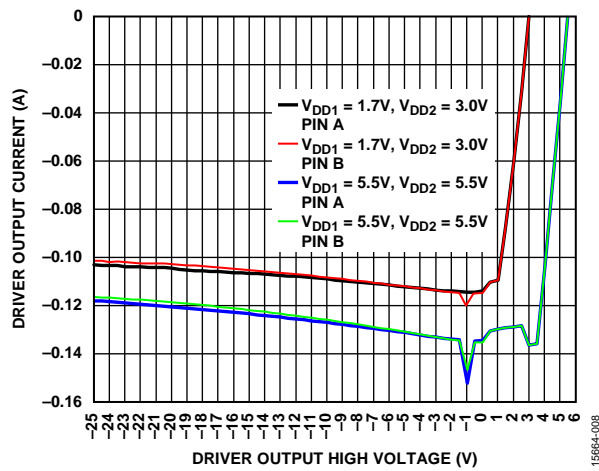

Figure 8. Driver Output Current vs. Driver Output High Voltage

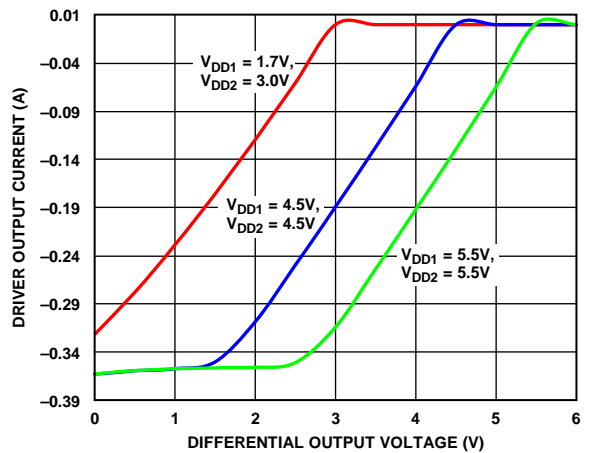

Figure 6. Driver Output Current vs. Differential Output Voltage

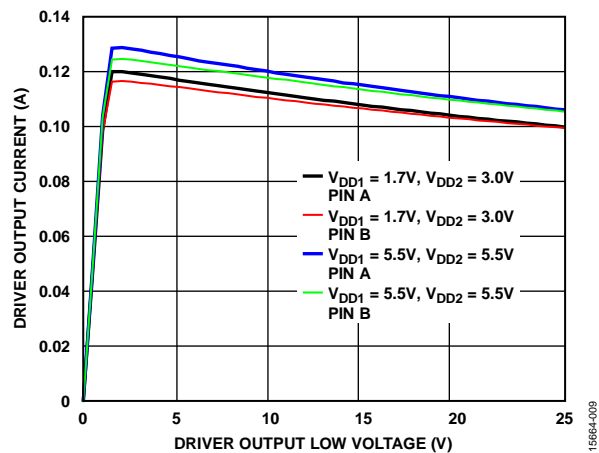

Figure 9. Driver Output Current vs. Driver Output Low Voltage

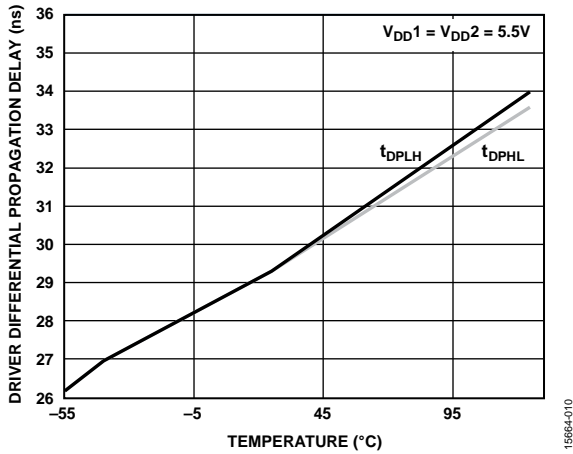

Figure 10. Driver Differential Propagation Delay vs. Temperature

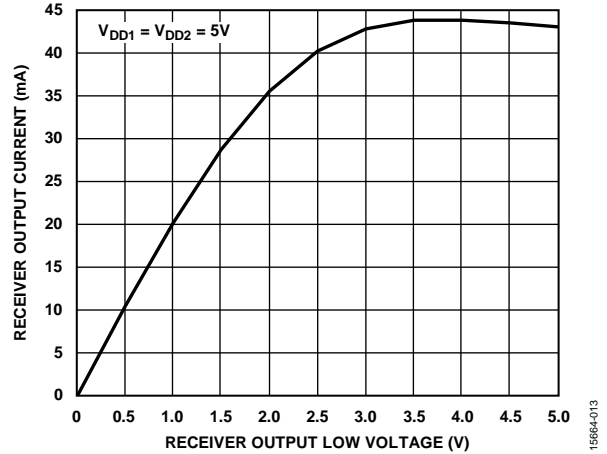

Figure 13. Receiver Output Current vs. Receiver Output Low Voltage

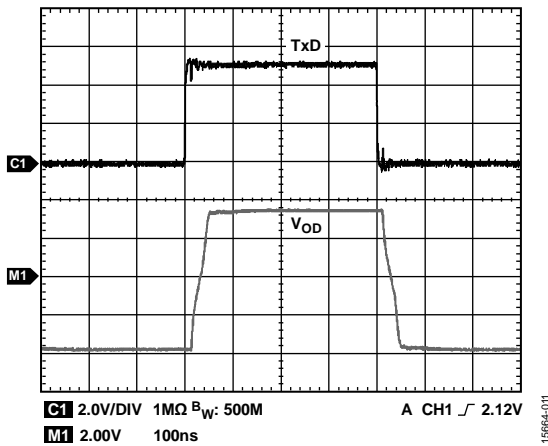

Figure 11. Driver Propagation Delay (Oscilloscope)

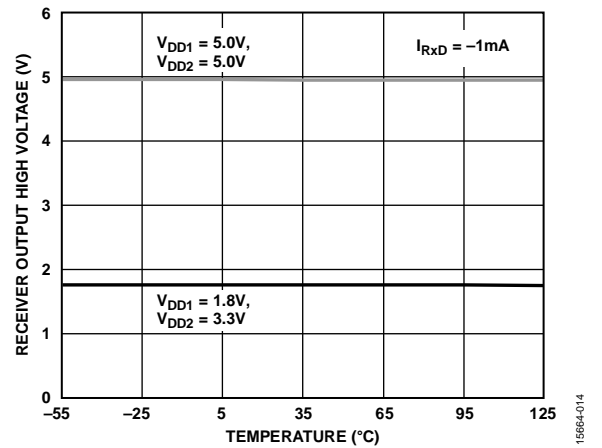

Figure 14. Receiver Output High Voltage vs. Temperature

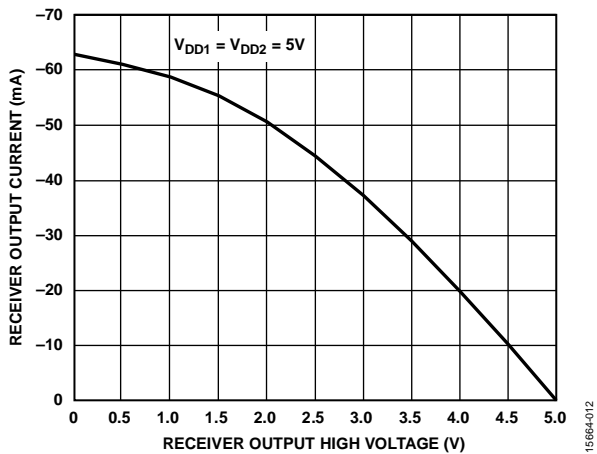

Figure 12. Receiver Output Current vs. Receiver Output High Voltage

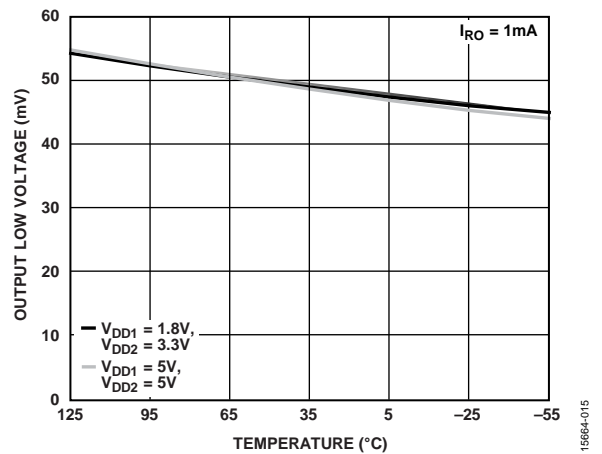

Figure 15. Receiver Output Low Voltage vs. Temperature

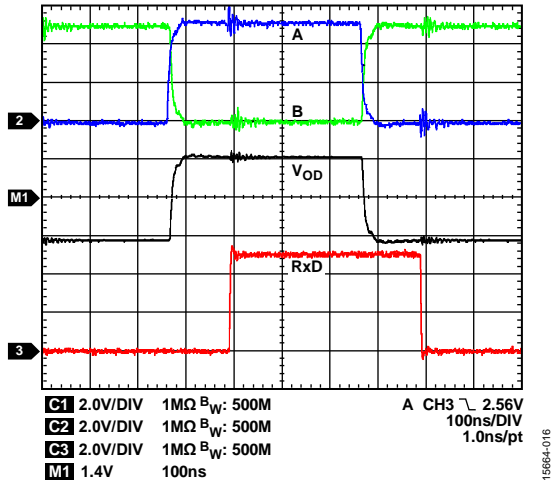

Figure 16. Receiver Propagation Delay (Oscilloscope)

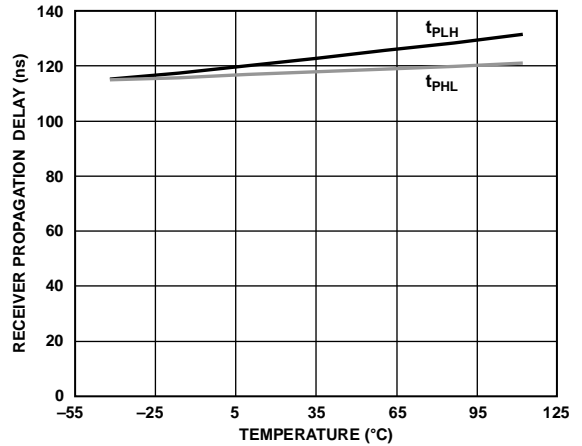

Figure 19. Receiver Propagation Delay vs. Temperature

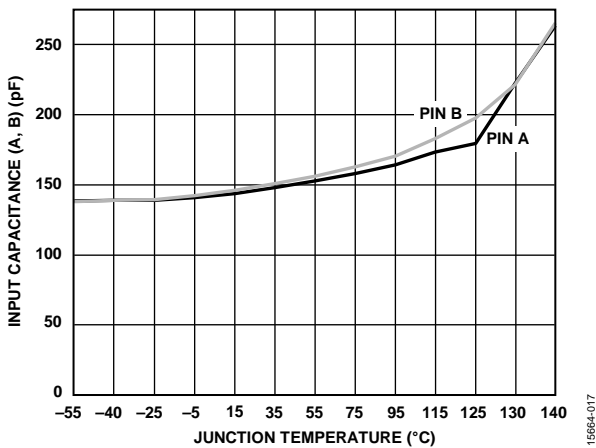

Figure 17. Input Capacitance (A, B) vs. Junction Temperature

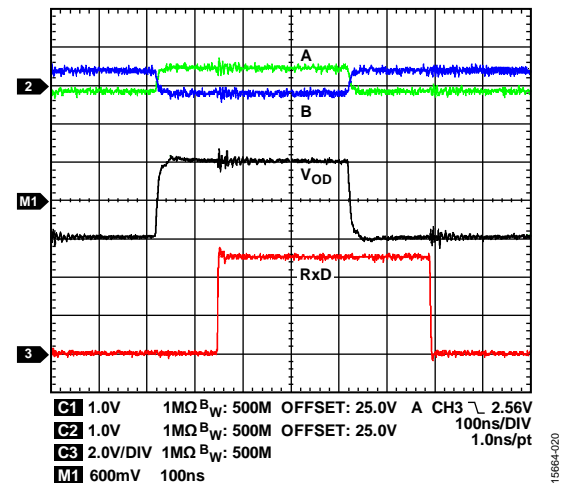

Figure 20. Receiver Performance with Input Common-Mode Voltage of 25 V

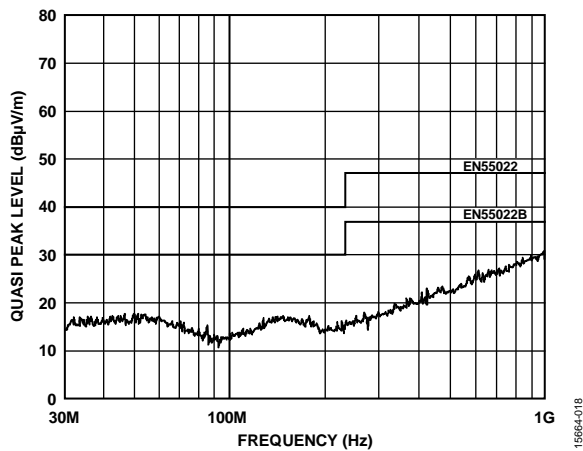

Figure 18. Radiated Emissions Profile with 120 pF Capacitor to GND₁ on the RxD Pin (Horizontal Scan, Data Rate = 2.5 Mbps, V_{DD1} = V_{DD2} = 5.0 V)

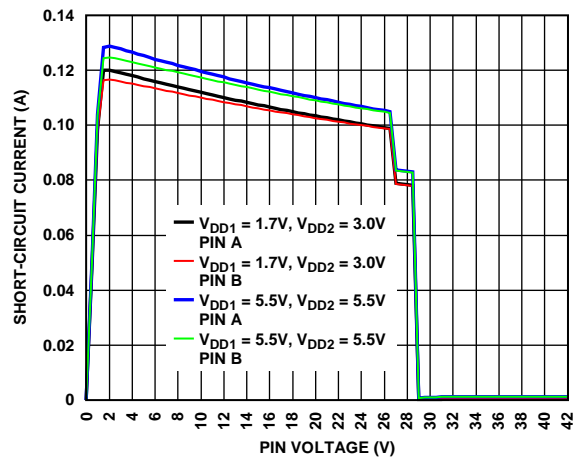

Figure 21. Short-Circuit Current over Fault Voltage Range

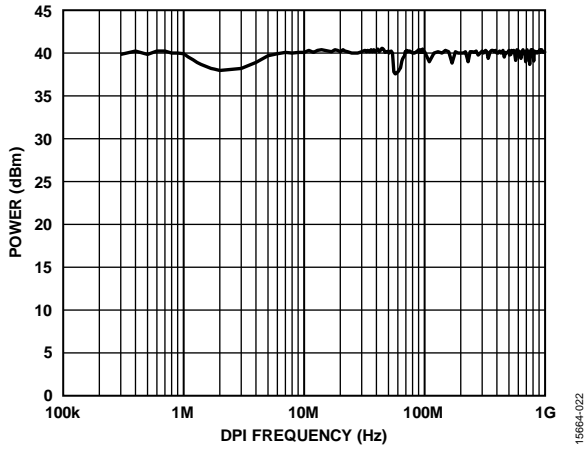

Figure 22. DPI IEC 62132-4 Noise Immunity with 100 nF and 10 μ F Decoupling on V_{DD1}

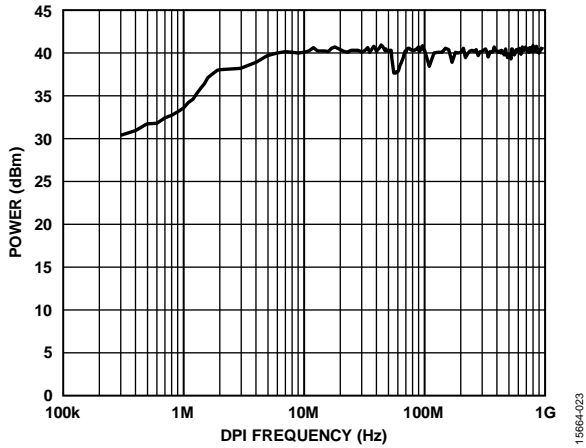

Figure 23. DPI IEC 62132-4 Noise Immunity with 100 nF Decoupling on V_{DD1}

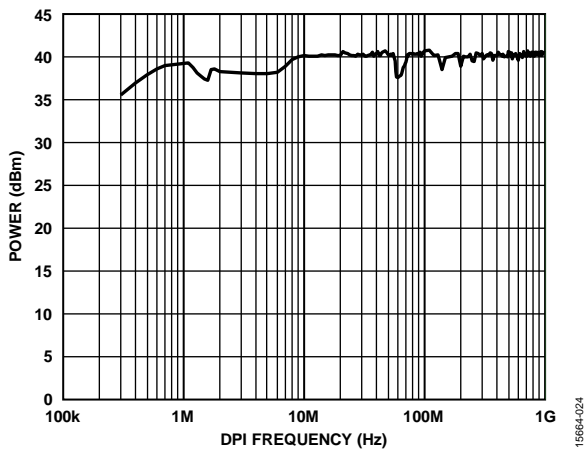

Figure 24. DPI IEC 62132-4 Noise Immunity with 100 nF and Decoupling on V_{DD2}

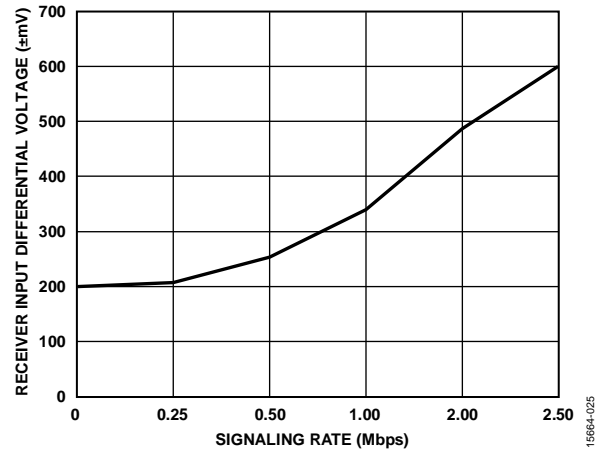

Figure 25. Receiver Input Differential Voltage (V_{ID}) vs. Signaling Rate

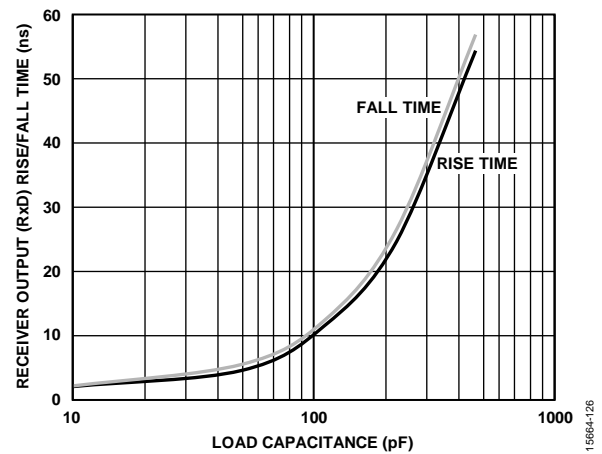

Figure 26. Receiver Output (RxD) Rise/Fall Time vs. Load Capacitance

TEST CIRCUITS

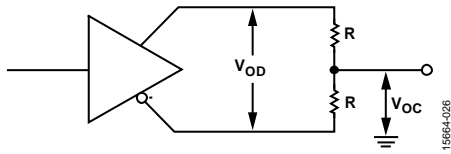

Figure 27. Driver Voltage Measurement

15664-028

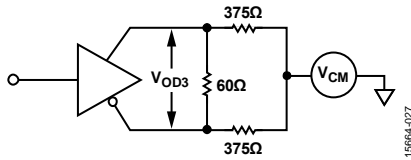

Figure 28. Driver Voltage Measurement over Common-Mode Voltage Range

15664-027

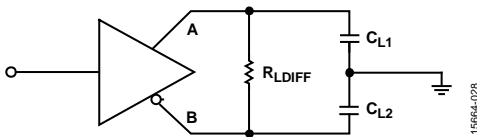

Figure 29. Driver Propagation Delay

15664-028

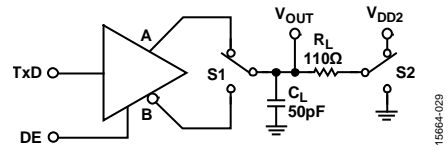

Figure 30. Driver Enable/Disable

15664-029

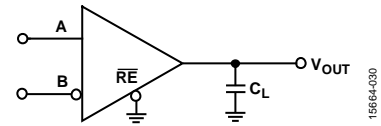

Figure 31. Receiver Propagation Delay

15664-030

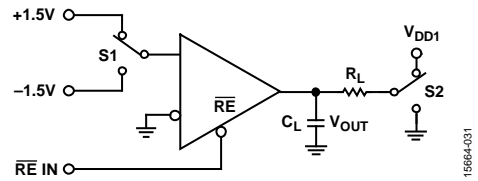

Figure 32. Receiver Enable/Disable

15664-031

SWITCHING CHARACTERISTICS

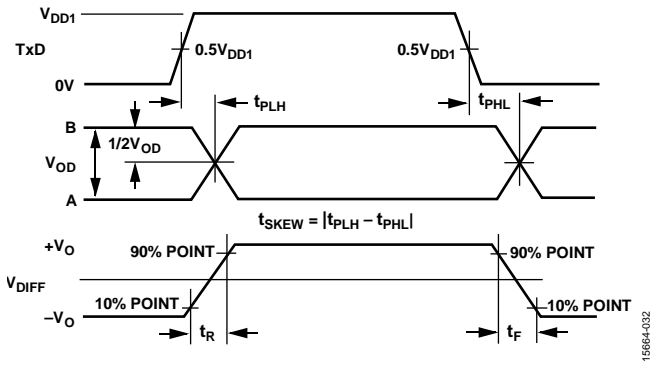

Figure 33. Driver Propagation Delay, Rise/Fall Timing

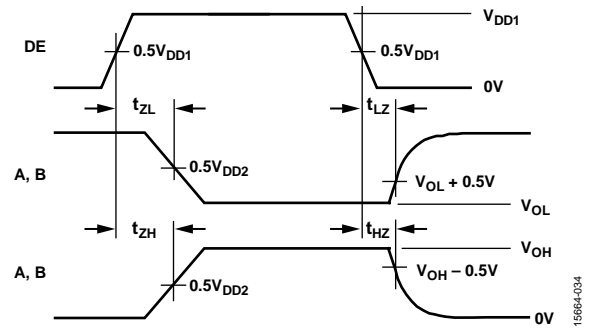

Figure 35. Driver Enable/Disable Timing

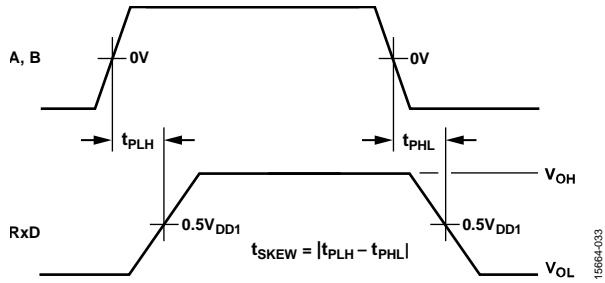

Figure 34. Receiver Propagation Delay

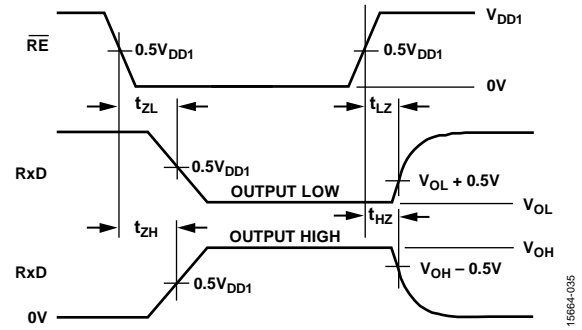

Figure 36. Receiver Enable/Disable Timing

THEORY OF OPERATION

RS-485 WITH ADDED DO-160G EMC ROBUSTNESS

The ADM2795E-EP is a 3 V to 5.5 V RS-485 transceiver with added robustness that reduces system failures when operating in harsh application environments such as military and aerospace (MILA) avionics for sensors, actuators, and engine control.

Lightning strikes to jet airliners are common, about once every 1000 flight hours. The DO-160G standard, *Environmental Conditions and Test Procedures for Airborne Equipment*, is a standard for the environmental testing of avionics hardware. Many airplane manufacturers specify DO-160G Section 22, lightning induced transient susceptibility, as a requirement for critical systems, like guidance, radars, communications, engine control, and heat and air controls. Aircraft radome, wing tips, fin tips, nacelles, and landing gear are areas most likely to be hit by lightning strikes.

The ADM2795E-EP integrates fully certified DO-160G EMC protection on the RS-485 bus pins, with Section 22 lightning protection. The ADM2795E-EP also provides Section 25 ±15 kV ESD air discharge protection. For Section 22 lightning, the ADM2795E-EP provides protection against Waveform 3, Waveform 4/Waveform 1, and Waveform 5A to Level 4 using 33 Ω or 47 Ω current limiting resistors to GND₂, or to Level 4 across the isolation barrier to GND₁.

CERTIFIED DO-160G EMC PROTECTION

Table 11 details the open circuit voltage (V_{OC}) and short-circuit current (I_{SC}) as specified in the DO-160G Section 22 lightning induced transient susceptibility standard for Waveform 3, Waveform 4/Waveform 1, and Waveform 5A for pin injection testing. The peak currents for the DO-160G Level 4 tests are much greater than standard industrial surge IEC 61000-4-5 peak currents. The waveform shape and rise/decay times for the DO-160G standard are significantly longer than those specified by the IEC 61000-4-5 standard, as shown in Figure 37. Due to

the high amounts of energy associated with the DO-160G Section 22 lightning standard, the ADM2795E-EP was tested using external 33 Ω or 47 Ω A pin and B pin bus current limiting resistors for testing to GND₂. These resistors were required in addition to the ADM2795E-EP integrated EMC protection circuitry. However, when testing to GND₁, no current limiting resistors are required. The ADM2795E-EP iCoupler isolation technology protects the device in the presence of these extreme transients.

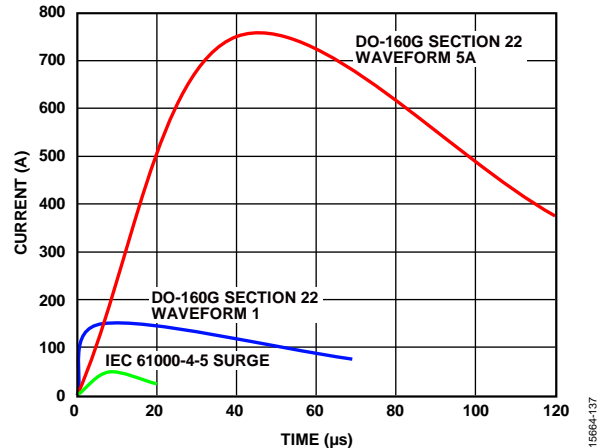

Figure 37. DO-160G Section 22 Waveform 1 and Waveform 5A, and IEC61000-4-5 Surge Waveform

DO-160G ADM2795E-EP TEST DETAILS

Figure 38 and Figure 39 show the Waveform 3 test setup coupling/decoupling network (CDN) and the Waveform 5A, Waveform 4/Waveform 1 CDN, respectively. For testing to RS-485 bus side, GND₂, an additional 33 Ω or 47 Ω current limiting resistance is added on both A and B bus pins. DO-160G Section 22 testing is performed on one pin at a time. The test is not performed in common mode. Table 12 and Table 13 show a summary of the ADM2795E-EP certified test results.

Table 11. DO-160G Section 22 Pin Injection Level 4 and Level 3 Compared to IEC 61000-4-5 Lightning Level 4 and Level 3

Level	DO-160G Waveform 3	DO-160G Waveform 4/Waveform 1	DO-160G Waveform 5A	IEC 61000-4-5
4	1500 V, 60 A	750 V, 150 A	750 V, 750 A	4000 V, 49 A
3	600 V, 24 A	300 V, 60 A	300 V, 300 A	2000 V, 24.5 A

Table 12. DO-160G Section 22 Pin Injection Level 4 Certified Test Results

Testing to GND _x	Current Limiting Resistor	DO-160 Waveform 3; 1500 V, 60 A	DO-160 Waveform 4/ Waveform 1; 750 V, 150 A	DO-160 Waveform 5A; 750 V, 750 A
GND ₁	None	Pass	Pass	Pass
GND ₂	47 Ω or 33 Ω	Pass with 47 Ω	Pass with 33 Ω	Pass with 33 Ω

Table 13. DO-160G Section 22 Pin Injection Level 3 Certified Test Results

Testing to GND _x	Current Limiting Resistor	DO-160 Waveform 3; 600 V, 24 A	DO-160 Waveform 4/ Waveform 1; 300 V, 60 A	DO-160 Waveform 5A; 300 V, 300 A
GND ₁	None	Pass	Pass	Pass
GND ₂	33 Ω	Pass	Pass	Pass

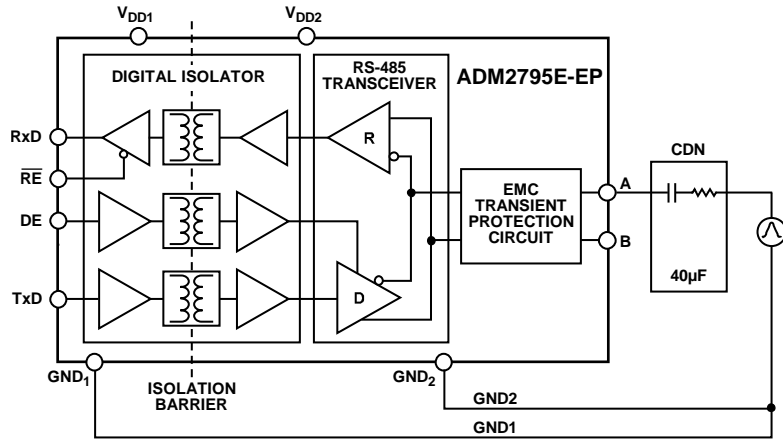

Figure 38. DO-160G Section 22 Waveform 3 Test Setup CDN

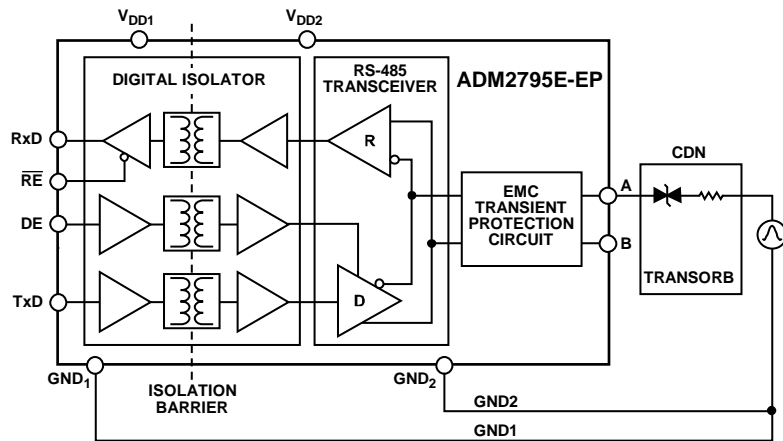
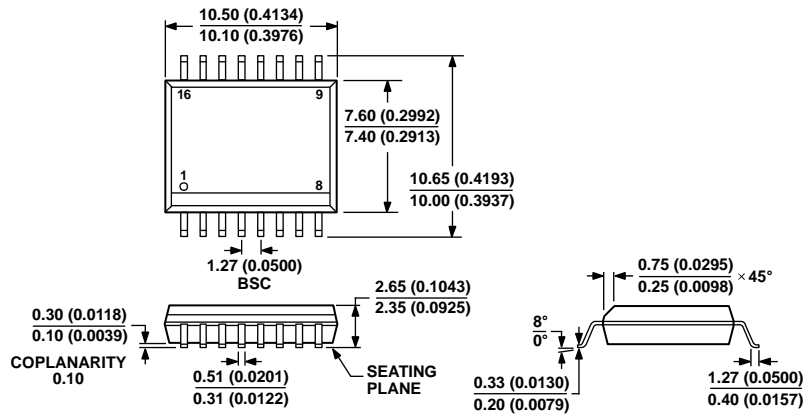

Figure 39. DO-160G Section 22 Waveform 5A, Waveform 4/Waveform 1 Test Setup CDN

OUTLINE DIMENSIONS



COMPLIANT TO JEDEC STANDARDS MS-013-AA
 CONTROLLING DIMENSIONS ARE IN MILLIMETERS; INCH DIMENSIONS
 (IN PARENTHESES) ARE ROUNDED-OFF MILLIMETER EQUIVALENTS FOR
 REFERENCE ONLY AND ARE NOT APPROPRIATE FOR USE IN DESIGN.

03-27-2007-B

Figure 40. 16-Lead Standard Small Outline Package [SOIC_W]
 Wide Body
 (RW-16)

Dimensions shown in millimeters and (inches)

ORDERING GUIDE

Model ¹	Temperature Range	Package Description	Package Option	Ordering Quantity
ADM2795ETRZW-EP	-55°C to +125°C	16-Lead Standard Small Outline Package [SOIC_W]	RW-16	
ADM2795ETRZW-EP-R7	-55°C to +125°C	16-Lead Standard Small Outline Package [SOIC_W], 7" Reel	RW-16	400
EVAL-ADM2795EEPZ		Evaluation Board		

¹ Z = RoHS Compliant Part.

Looking for pricing, stock, or lifecycle information?

Click below to explore more details on WIN SOURCE:

 [View ADM2795ETRWZ-EP on WIN SOURCE](#)

 [Analog Devices Inc. Information](#)

Optimize Your Supply Chain with WIN SOURCE Solutions

-  Global Sourcing Solution
-  Obsolete Management
-  Cost Control Management
-  Shortage Management
-  Alternative Solution
-  Excess Inventory Management