



THE DATASHEET OF CAT823SSDI-GT3



System Supervisory Voltage Reset with Watchdog and Manual Reset

CAT823, CAT824



TSOT-23
TD SUFFIX
CASE 419AE

Description

The CAT823 and CAT824 provide basic reset and monitoring functions for the electronic systems. Each device monitors the system voltage and maintains a reset output until that voltage reaches the device’s specified trip value and then maintains the reset output active condition until the device’s internal timer, after a minimum timer of 140 ms; to allow the systems power supply to stabilize.

The CAT823 and CAT824 also have a watchdog input which can be used to monitor a system signal and cause a reset to be issued if the signal fails to change state prior to a timeout condition.

The CAT823 also provides a manual reset input which can be used to initiate reset if pulled low. This input can be directly attached to a push-button or a processor signal.

Features

- Automatically Restarts Microprocessor after Power Failure
- Monitors Pushbutton for External Override
- Accurate Under Voltage System Monitoring
- Brownout Detection System Reset for use with 3.0, 3.3, and 5.0 V Systems
- Pin and Function Compatible with the MAX823/24 Products
- Operating Range from -40°C to +85°C
- Available in TSOT-23 5-lead Package
- These Devices are Pb-Free, Halogen Free/BFR Free and are RoHS Compliant

Applications

- Microprocessor and Microcontroller Based Systems
- Intelligent Instruments
- Control Systems
- Critical μ P Monitors
- Portable Equipment

PIN FUNCTIONS

Pin Name	Function
RESET	CMOS Push-Pull Active Low Reset Output
GND	Ground
MR	Manual Reset input – Pulled high Internally by a 52 k Ω resistor designed to be driven low by a mechanical pushbutton, open drain output or CMOS output.
RESET	CMOS Push-Pull Active High Reset Output
WDI	Watchdog Timer Input – Designed to be driven by a processor output or can be disabled by tri-stating or leaving open.
V _{CC}	Power Supply

PIN CONNECTIONS

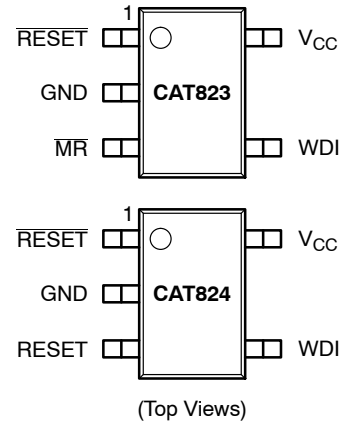

MARKING DIAGRAM

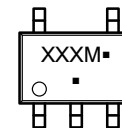

XXX = Specific Device Code
M = Date Code
▪ = Pb-Free Package*

(Note: Microdot may be in either location)

ORDERING INFORMATION

See detailed ordering and shipping information in the package dimensions section on page 9 of this data sheet.

NOTE: Some of the devices on this data sheet have been **DISCONTINUED**. Please refer to the table on page 9.

CAT823, CAT824

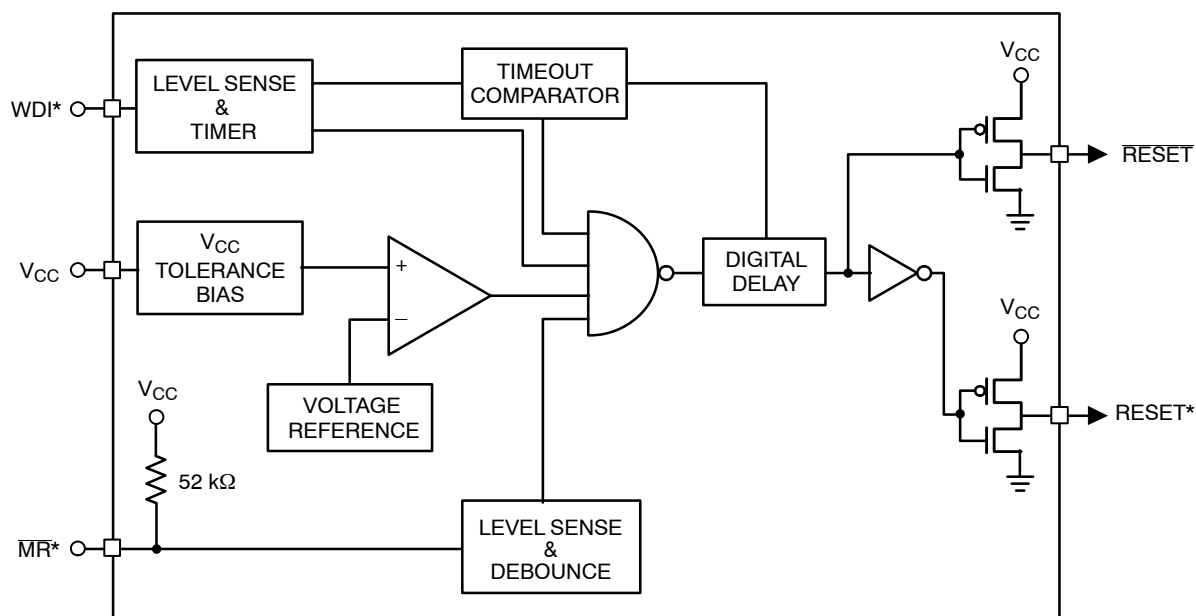

* Functions Available by Device

Figure 1. Block Diagram

Device	RESET	RESE*	MR	WDI
CAT823	x		x	x
CAT824	x	x		x

Table 1. ABSOLUTE MAXIMUM RATINGS

Parameters	Ratings	Units
Supply Voltage	6	V
All other pins	-0.3 to ($V_{CC} + 0.3$)	V
Input Current, V_{CC}	20	mA
Output Current RESET, RESE*	20	mA
Continuous Power Dissipations ($T_A = +70^\circ\text{C}$) TSOT-23 5-lead (derate 7.1 mW/ $^\circ\text{C}$ above $+70^\circ\text{C}$)	571	mW
Storage Temperature	-65 to 150	$^\circ\text{C}$
Operating Ambient Temperature	-40 to +85	$^\circ\text{C}$
Lead Soldering (10 seconds max)	+300	$^\circ\text{C}$
ESD Rating: Low Voltage Pins Human Body Model Machine Model	2000 200	V

Stresses exceeding those listed in the Maximum Ratings table may damage the device. If any of these limits are exceeded, device functionality should not be assumed, damage may occur and reliability may be affected.

Table 2. RECOMMENDED OPERATING CONDITIONS

Parameter	Range	Units
V_{CC} ($T_A = 0^\circ\text{C}$ to $+70^\circ\text{C}$)	1.0 to 5.5	V
V_{CC} ($T_A = -40^\circ\text{C}$ to $+85^\circ\text{C}$)	1.2 to 5.5	V
All Other Pins	-0.1 to ($V_{CC} + 0.1$)	V
Ambient Temperature	-40 to +85	$^\circ\text{C}$

CAT823, CAT824

Table 3. ELECTRICAL OPERATING CHARACTERISTICS

(DC Characteristics: $V_{CC} = 3.0\text{ V}$ to 5.5 V for M version; $V_{CC} = 2.0\text{ V}$ to 3.6 V for the R/S/T/U/Y/Z version, $-40^{\circ}\text{C} \leq T_A \leq +85^{\circ}\text{C}$ unless otherwise noted. Typical Values at $T_A = 25^{\circ}\text{C}$ and $V_{CC} = 5\text{ V}$ for M version; $V_{CC} = 3.3\text{ V}$ for the T/S versions; $V_{CC} = 3.0\text{ V}$ for the R version; and $V_{CC} = 2.5\text{ V}$ for the U/Y/Z versions.) (Note 1)

Symbol	Parameter	Conditions	Min	Typ	Max	Units
I_{CC}	Supply Current	CAT824 (M Version)		6	17	μA
		CAT823 (R/S/T/Y/Z Versions) CAT824 (M/U Versions)		4	12	
V_{RST}	Reset Threshold	CAT82_M at $-40^{\circ}\text{C} \leq T_A \leq +85^{\circ}\text{C}$	4.25	4.38	4.50	V
		CAT82_T at $-40^{\circ}\text{C} \leq T_A \leq +85^{\circ}\text{C}$	3.00	3.08	3.15	
		CAT82_S at $-40^{\circ}\text{C} \leq T_A \leq +85^{\circ}\text{C}$	2.85	2.93	3.00	
		CAT82_R at $-40^{\circ}\text{C} \leq T_A \leq +85^{\circ}\text{C}$	2.55	2.63	2.70	
		CAT82_Z at $-40^{\circ}\text{C} \leq T_A \leq +85^{\circ}\text{C}$	2.25	2.32	2.38	
		CAT82_Y at $-40^{\circ}\text{C} \leq T_A \leq +85^{\circ}\text{C}$	2.13	2.19	2.25	
		CAT824U at $-40^{\circ}\text{C} \leq T_A \leq +85^{\circ}\text{C}$	1.95	2.00	2.05	
	Reset Threshold Tempco			40		ppm/ $^{\circ}\text{C}$
	Reset Threshold Hysteresis	CAT82_M		10		mV
		CAT82_R/S/T/Y/Z, CAT824U		5		
t_{RD}	V_{CC} to Reset Delay (Note 2)	$V_{CC} = V_{TH}$ to $(V_{TH} - 100\text{ mV})$		20		μs
t_{RP}	Reset Active Timeout Period		140	200	400	ms
V_{OH}	RESET Output High Voltage	CAT82_M, $V_{CC} = V_{RST\text{ max}}$, $I_{SOURCE} = -120\ \mu\text{A}$	$V_{CC} - 1.5\text{ V}$			V
		CAT82_T/S/R/Z/Y, CAT824U, $V_{CC} = \bar{V}_{RST\text{ max}}$, $I_{SOURCE} = -30\ \mu\text{A}$	$0.8 \times V_{CC}$			
V_{OL}	RESET Output Low Voltage	CAT82_M, $V_{CC} = V_{RST\text{ min}}$, $I_{SINK} = 3.2\text{ mA}$			0.4	V
		CAT82_T/S/R/Z/Y, CAT824U, $V_{CC} = \bar{V}_{RST\text{ min}}$, $I_{SINK} = 1.2\text{ mA}$			0.3	
		$T_A = 0^{\circ}\text{C}$ to $+70^{\circ}\text{C}$, $V_{CC} = 1\text{ V}$, V_{CC} falling, $I_{SINK} = 50\ \mu\text{A}$			0.3	
		$T_A = T_{MIN}$ to T_{MAX} , $V_{CC} = 1.2\text{ V}$, V_{CC} falling, $I_{SINK} = 100\ \mu\text{A}$			0.3	
I_{SOURCE}	RESET Output Short-Circuit Current	CAT82_M, Reset = 0 V, $V_{CC} = 5.5\text{ V}$			1.5	mA
		CAT82_M, Reset = 0 V, $V_{CC} = 3.6\text{ V}$			0.8	
V_{OH}	Reset Output Voltage	$V_{CC} > 1.8\text{ V}$, $I_{SOURCE} = -150\ \mu\text{A}$	$0.8 \times V_{CC}$			V
V_{OL}		CAT824M, $V_{CC} = V_{RST\text{ max}}$, $I_{SINK} = 3.2\text{ mA}$			0.4	
		CAT824M/U, $V_{CC} = V_{RST\text{ max}}$, $I_{SINK} = 1.2\text{ mA}$			0.3	

WATCHDOG INPUT (CAT823 & CAT824)

t_{WD}	Watchdog Timeout Period		1.12	1.60	3.20	s
t_{WDI}	WDI Pulse Width	$V_{IL} = 0.4\text{ V}$, $V_{IH} = 0.8 \times V_{CC}$	50			ns
V_{IL}	WDI Input Voltage (Note 3)				$0.3 \times V_{CC}$	V
V_{IH}						
	WDI Input Current (Note 4)	WDI = V_{CC} , Time Average		120	160	μA
		WDI = 0 V, Time Average	-20	-15		

CAT823, CAT824

Table 3. ELECTRICAL OPERATING CHARACTERISTICS (continued)

(DC Characteristics: $V_{CC} = 3.0\text{ V}$ to 5.5 V for M version; $V_{CC} = 2.0\text{ V}$ to 3.6 V for the R/S/T/U/Y/Z version, $-40^{\circ}\text{C} \leq T_A \leq +85^{\circ}\text{C}$ unless otherwise noted. Typical Values at $T_A = 25^{\circ}\text{C}$ and $V_{CC} = 5\text{ V}$ for M version; $V_{CC} = 3.3\text{ V}$ for the T/S versions; $V_{CC} = 3.0\text{ V}$ for the R version; and $V_{CC} = 2.5\text{ V}$ for the U/Y/Z versions.) (Note 1)

Symbol	Parameter	Conditions	Min	Typ	Max	Units
MANUAL RESET INPUT (CAT823)						
V_{IL}	$\overline{\text{MR}}$ Input Voltage				$0.3 \times V_{CC}$	V
V_{IH}			$0.7 \times V_{CC}$			
t_{PB}	$\overline{\text{MR}}$ Pulse Width		1			μs
t_{PDLY}	$\overline{\text{MR}}$ low to Reset Delay				5	μs
	$\overline{\text{MR}}$ Noise Immunity	Pulse Width with No Reset		100		ns
	$\overline{\text{MR}}$ Pullup Resistance (internal)		35	52	75	$\text{k}\Omega$

Product parametric performance is indicated in the Electrical Characteristics for the listed test conditions, unless otherwise noted. Product performance may not be indicated by the Electrical Characteristics if operated under different conditions.

1. Over-temperature limits are guaranteed by design and not production tested.
2. The RESET short-circuit current is the maximum pull-up current when reset is driven low by a bidirectional output.
3. WDI is internally serviced within the watchdog period if WDI is left open.
4. The WDI input current is specified as an average input current when the WDI input is driven high or low. The WDI input if connected to a three-stated output device can be disabled in the tristate mode as long as the leakage current is less than $10\text{ }\mu\text{A}$ and a maximum capacitance of less than 200 pF . To clock the WDI input in the active mode the drive device must be able to source or sink at least $200\text{ }\mu\text{A}$ when active.

TYPICAL ELECTRICAL OPERATING CHARACTERISTICS

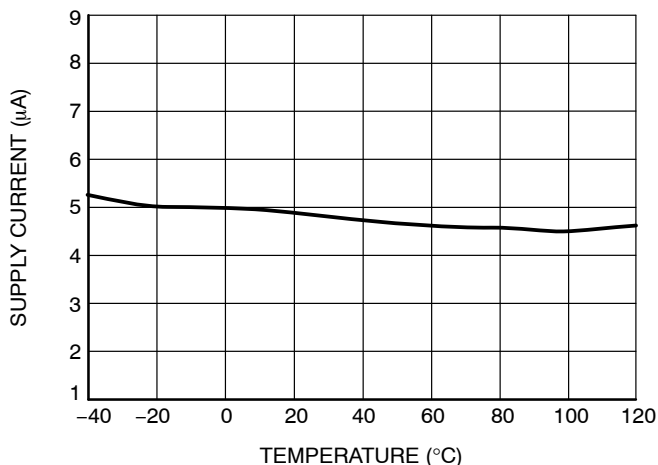

Figure 2. V_{CC} Supply Current vs. Temperature

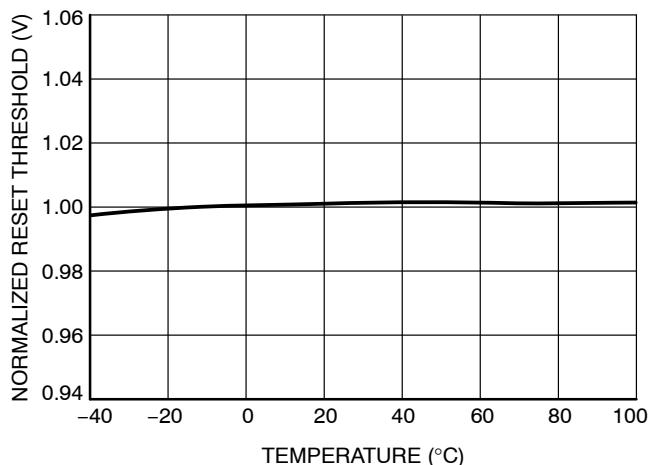

Figure 3. Normalized Reset Threshold Voltage vs. Temperature

CAT823, CAT824

FUNCTIONAL DESCRIPTION

Processor RESET

The CAT823 detects supply voltage (V_{CC}) conditions that are below the specified voltage trip value (V_{RST}) and provide a reset output to maintain correct system operation. On power-up, \overline{RESET} (and RESET if available) are kept active for a minimum delay t_{RP} of 140 ms after the supply voltage (V_{CC}) rises above V_{RST} to allow the power supply and processor to stabilize. When V_{CC} drops below the voltage trip value (V_{RST}), the reset output signals \overline{RESET} (and RESET) are pulled active. \overline{RESET} (and RESET if available) is specifically designed to provide the reset input signals for processors. This provides reliable and consistent operation as power is turned on, off or during brownout conditions by maintaining the processor operation in known conditions.

Manual RESET

The CAT823 has a Manual Reset (\overline{MR}) input to allow for alternative control of the reset outputs. The \overline{MR} input is designed for direct connection to a pushbutton (see Figure 4). The \overline{MR} input is internally pulled up by 52 k Ω resistor and must be pulled low to cause the reset outputs to go active. Internally, this input is debounced and timed such that \overline{RESET} (and RESET) signals of at least 140 ms minimum will be generated. The min 140 ms t_{RP} delay commences as the Manual Reset input is released from the low level (see Figure 5).

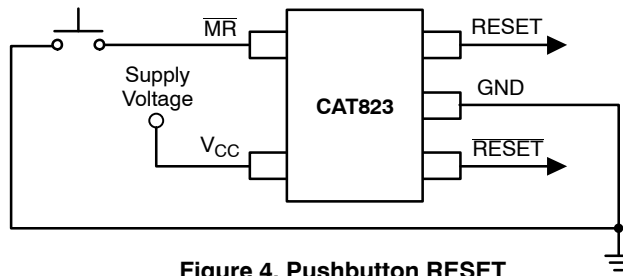

Figure 4. Pushbutton RESET

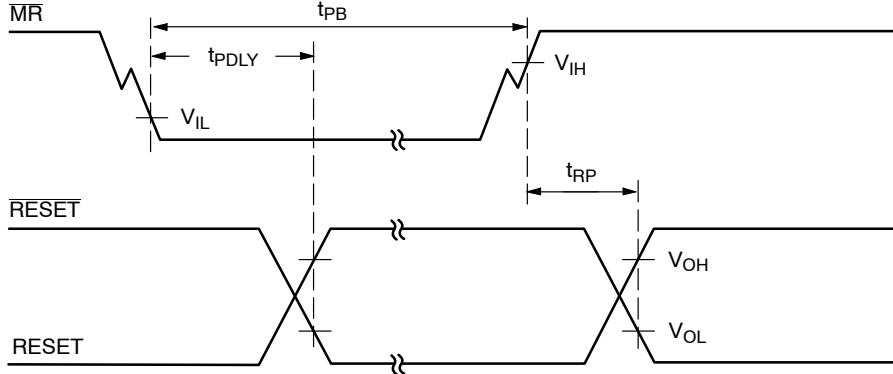

Figure 5. Timing Diagram – Pushbutton RESET

CAT823, CAT824

Watchdog Timer

The CAT823 and CAT824 provide a Watchdog input (WDI). The watchdog timer function forces $\overline{\text{RESET}}$ (and RESET in the CAT824) signals active when the WDI input does not have a transition from low-to-high or high-to-low within 1.12 seconds. Timeout of the watchdog starts when $\overline{\text{RESET}}$ (RESET on the CAT824) becomes inactive. If a transition occurs on the WDI input pin prior to the watchdog time-out, the watchdog timer is reset and begins to time-out again. If the watchdog timer is allowed to time-out, then the reset output(s) will go active for t_{RP} and once released will repeat the watchdog timeout process.

Figure 6 below shows a typical implementation of a watchdog function. Any processor signal that repeats dependant on the normal operation of the processor or directed by the software operating on the processor can be

used to strobe the watchdog input. The most reliable is a dedicated I/O output transitioned by a specific software instruction.

The watchdog can be disabled by floating (or tri-stating) the WDI input (see Figure 7). If the watchdog is disabled the WDI pin will be pulled low for the first 7/8th's of the watchdog period (t_{WD}) and pulled high for the last 1/8th of the watchdog period. This pulling low of the WDI input and then high is used to detect an open or tri-state condition and will continue to repeat until the WDI input is driven high or low.

For most efficient operation of devices with the watchdog function the WDI input should be held low the majority of the time and only strobed high as required to reset the watchdog timer.

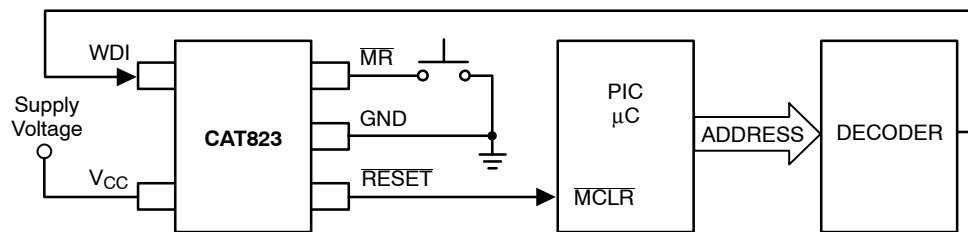

Figure 6. Watchdog Timer

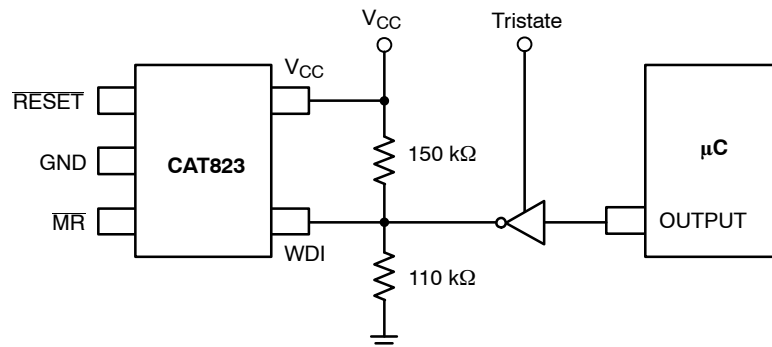

Figure 7. Watchdog Disable Circuit

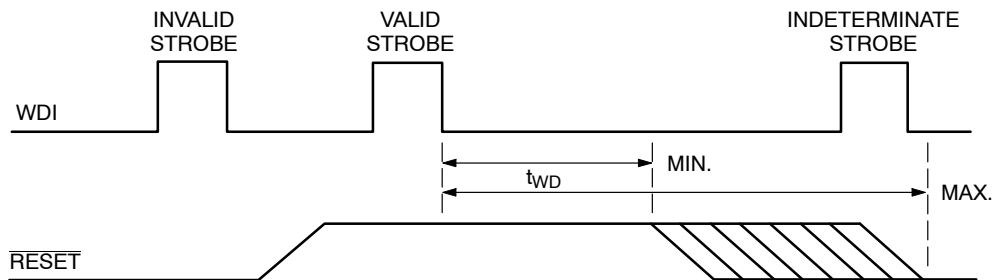

Figure 8. Timing Diagram – Strobe Input

CAT823, CAT824

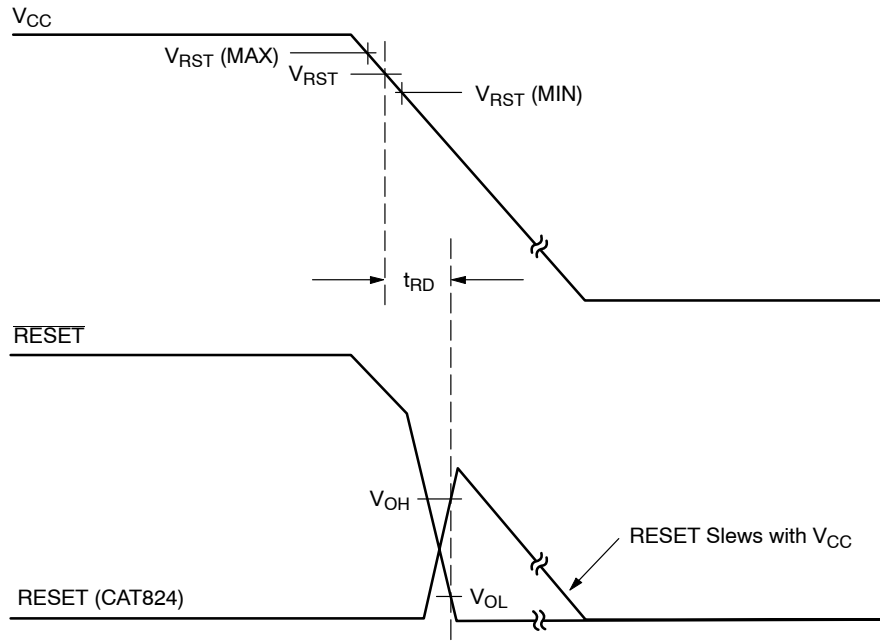

Figure 9. Timing Diagram – Power Down

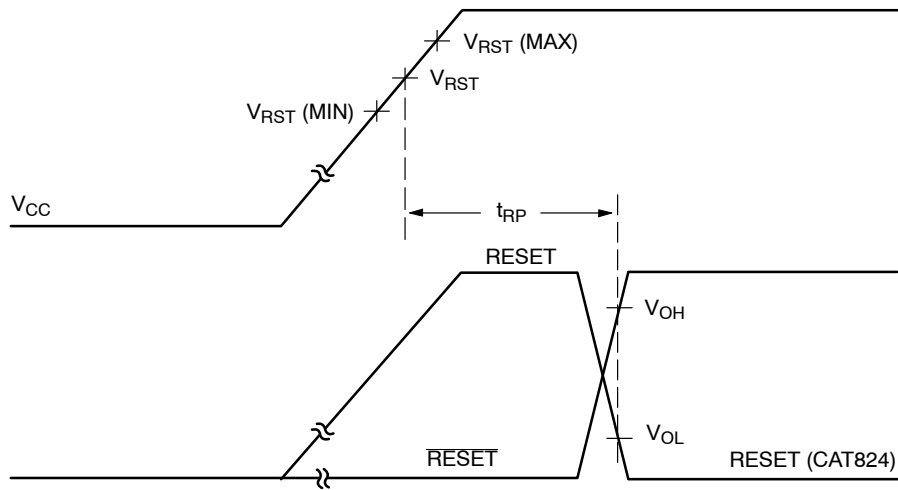

Figure 10. Timing Diagram – Power Up

CAT823, CAT824

Application Notes

μ P's with Bidirectional Reset Pins

The $\overline{\text{RESET}}$ output can be pulled low by processors like the 68HC11 allowing for a system reset issued by the processor. The maximum pullup current that can be sourced by the CAT82_M is 1.5 mA (and by the CAT82_T/R/S/Z/Y is 800 μ A) allowing the processor to pull the output low even when the CAT82x is pulling it high.

Power Transients

Generally short duration negative-going transients of less than 2 μ s on the power supply at V_{RST} minimum will not cause a reset condition. However the lower the voltage of the transient the shorter the required time to cause a reset output. These issues can usually be remedied by the proper location of bypass capacitance on the circuit board.

Output Valid Conditions

The $\overline{\text{RESET}}$ output uses a push-pull output which can maintain a valid output down to a V_{CC} of 1.0 volts. To sink current below 0.8 V a resistor can be connected from $\overline{\text{RESET}}$ to Ground (see Figure 11.) This arrangement will maintain a valid value on the $\overline{\text{RESET}}$ output during both power up and down but will draw current when the $\overline{\text{RESET}}$ output is in the high state. A resistor value of about 100 k Ω should be adequate in most situations to maintain a low condition valid output down to V_{CC} equal to 0 V.

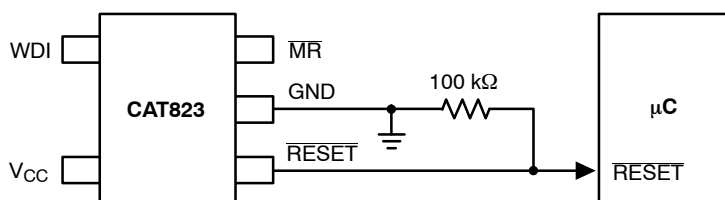

Figure 11. $\overline{\text{RESET}}$ Valid to 0 Volts V_{CC}

CAT823, CAT824

ORDERING INFORMATION

Order Number	Voltage	Top Mark	Inputs		Outputs		Package	Shipping†
NiPdAu		NiPdAu	MR	WDI	RESET	RESET		
CAT823TTDI-GT3	3.08 V	ETA	*	*	*		TSOT-23-5	3,000 / Tape & Reel

DISCONTINUED (Note 9)

CAT823STDI-GT3	2.93 V	ETA	*	*	*		TSOT-23-5	3,000 / Tape & Reel
CAT823RTDI-GT3	2.63 V	ETA	*	*	*			
CAT823ZTDI-GT3	2.32 V	ETA	*	*	*			
CAT823YTDI-GT3	2.19 V	ETA	*	*	*			

CAT824MTDI-GT3	4.38 V	EFA		*	*	*	TOST-23-5	3,000 / Tape & Reel
CAT824UTDI-GT3	2.00 V	EFA		*	*	*		

†For information on tape and reel specifications, including part orientation and tape sizes, please refer to our Tape and Reel Packaging Specifications Brochure, [BRD8011/D](#).

5. All packages are RoHS-compliant (Lead-free, Halogen-free).

6. The standard lead finish is NiPdAu.

7. Contact factory for package availability.

8. For detailed information and a breakdown of device nomenclature and numbering systems, please see the **onsemi** Device Nomenclature document, [TND310/D](#).

9. **DISCONTINUED:** These devices are not recommended for new design. Please contact your **onsemi** representative for information. The most current information on these devices may be available on www.onsemi.com.

MECHANICAL CASE OUTLINE

PACKAGE DIMENSIONS

ON Semiconductor®



TSOT-23, 5 LEAD
CASE 419AE-01
ISSUE O

DATE 19 DEC 2008

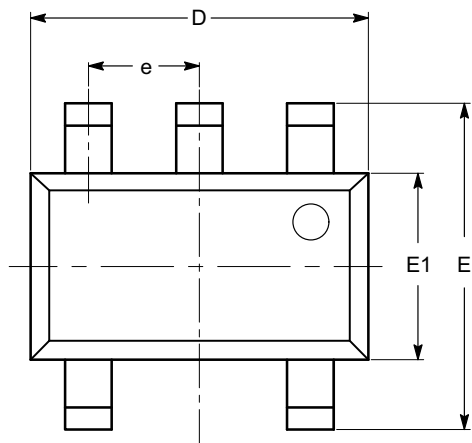

TOP VIEW

SYMBOL	MIN	NOM	MAX
A			1.00
A1	0.01	0.05	0.10
A2	0.80	0.87	0.90
b	0.30		0.45
c	0.12	0.15	0.20
D	2.90 BSC		
E	2.80 BSC		
E1	1.60 BSC		
e	0.95 TYP		
L	0.30	0.40	0.50
L1	0.60 REF		
L2	0.25 BSC		
θ	0°		8°

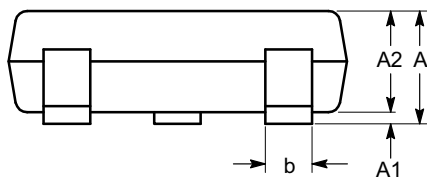

SIDE VIEW

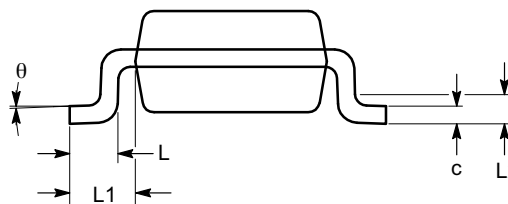

END VIEW

Notes:

- (1) All dimensions are in millimeters. Angles in degrees.
- (2) Complies with JEDEC MO-193.

DOCUMENT NUMBER:	98AON34392E	Electronic versions are uncontrolled except when accessed directly from the Document Repository. Printed versions are uncontrolled except when stamped "CONTROLLED COPY" in red.
DESCRIPTION:	TSOT-23, 5 LEAD	PAGE 1 OF 1

ON Semiconductor and are trademarks of Semiconductor Components Industries, LLC dba ON Semiconductor or its subsidiaries in the United States and/or other countries. ON Semiconductor reserves the right to make changes without further notice to any products herein. ON Semiconductor makes no warranty, representation or guarantee regarding the suitability of its products for any particular purpose, nor does ON Semiconductor assume any liability arising out of the application or use of any product or circuit, and specifically disclaims any and all liability, including without limitation special, consequential or incidental damages. ON Semiconductor does not convey any license under its patent rights nor the rights of others.

onsemi, **Onsemi**, and other names, marks, and brands are registered and/or common law trademarks of Semiconductor Components Industries, LLC dba "**onsemi**" or its affiliates and/or subsidiaries in the United States and/or other countries. **onsemi** owns the rights to a number of patents, trademarks, copyrights, trade secrets, and other intellectual property. A listing of **onsemi**'s product/patent coverage may be accessed at www.onsemi.com/site/pdf/Patent-Marking.pdf. **onsemi** reserves the right to make changes at any time to any products or information herein, without notice. The information herein is provided "as-is" and **onsemi** makes no warranty, representation or guarantee regarding the accuracy of the information, product features, availability, functionality, or suitability of its products for any particular purpose, nor does **onsemi** assume any liability arising out of the application or use of any product or circuit, and specifically disclaims any and all liability, including without limitation special, consequential or incidental damages. Buyer is responsible for its products and applications using **onsemi** products, including compliance with all laws, regulations and safety requirements or standards, regardless of any support or applications information provided by **onsemi**. "Typical" parameters which may be provided in **onsemi** data sheets and/or specifications can and do vary in different applications and actual performance may vary over time. All operating parameters, including "Typicals" must be validated for each customer application by customer's technical experts. **onsemi** does not convey any license under any of its intellectual property rights nor the rights of others. **onsemi** products are not designed, intended, or authorized for use as a critical component in life support systems or any FDA Class 3 medical devices or medical devices with a same or similar classification in a foreign jurisdiction or any devices intended for implantation in the human body. Should Buyer purchase or use **onsemi** products for any such unintended or unauthorized application, Buyer shall indemnify and hold **onsemi** and its officers, employees, subsidiaries, affiliates, and distributors harmless against all claims, costs, damages, and expenses, and reasonable attorney fees arising out of, directly or indirectly, any claim of personal injury or death associated with such unintended or unauthorized use, even if such claim alleges that **onsemi** was negligent regarding the design or manufacture of the part. **onsemi** is an Equal Opportunity/Affirmative Action Employer. This literature is subject to all applicable copyright laws and is not for resale in any manner.

ADDITIONAL INFORMATION

TECHNICAL PUBLICATIONS:



Technical Library: www.onsemi.com/design/resources/technical-documentation
onsemi Website: www.onsemi.com

ONLINE SUPPORT: www.onsemi.com/support

For additional information, please contact your local Sales Representative at www.onsemi.com/support/sales

Looking for pricing, stock, or lifecycle information?

Click below to explore more details on WIN SOURCE:

-  [View CAT823SSDI-GT3 on WIN SOURCE](#)
-  [ON Semiconductor](#) Information

Optimize Your Supply Chain with WIN SOURCE Solutions

-  Global Sourcing Solution
-  Obsolete Management
-  Cost Control Management
-  Shortage Management
-  Alternative Solution
-  Excess Inventory Management