



**THE DATASHEET OF  
FT312D-32Q1C-T**



# Future Technology Devices International Ltd.

## DS\_FT312D (USB Android Host IC)



The FT312D is a USB 2.0 Full Speed host IC specifically targeted at providing access to peripheral hardware from an Android platform with a USB device port. The device will bridge the USB port to a UART interface via the Android Open Accessory protocol and has the following advanced features:

- Single chip USB to UART interface.
- Entire USB protocol handled on the chip. No USB specific firmware programming required.
- Supports USB bulk transfer mode
- Basic UART interface with RXD, TXD, RTS#, CTS# pins.
- TX\_ACTIVE signal for controlling transceivers on RS485 interfaces.
- UART RX buffer size is 5512 bytes
- UART TX buffer size is 256 bytes
- USB\_ERROR indicator pin
- Suitable for use on any Android platform supporting Android Open Accessory Mode (Typically 3.1 onwards, however some platforms may port Open Accessory Mode to version 2.3.4)
- 12MHz oscillator using external crystal.
- Integrated power-on-reset circuit.
- +3V3 Single Supply Operation with 5V tolerant inputs.
- USB 2.0 Full Speed compatible.
- Extended operating temperature range; -40°C to 85°C.
- Available in compact Pb-free 32 Pin LQFP and QFN packages (both RoHS compliant).

Neither the whole nor any part of the information contained in, or the product described in this manual, may be adapted or reproduced in any material or electronic form without the prior written consent of the copyright holder. This product and its documentation are supplied on an as-is basis and no warranty as to their suitability for any particular purpose is either made or implied. Future Technology Devices International Ltd will not accept any claim for damages howsoever arising as a result of use or failure of this product. Your statutory rights are not affected. This product or any variant of it is not intended for use in any medical appliance, device or system in which the failure of the product might reasonably be expected to result in personal injury. This document provides preliminary information that may be subject to change without notice. No freedom to use patents or other intellectual property rights is implied by the publication of this document. Future Technology Devices International Ltd, Unit 1, 2 Seaward Place, Centurion Business Park, Glasgow G41 1HH United Kingdom. Scotland Registered Company Number: SC136640

## 1 Typical Applications

- Connecting Android phones to USB accessories
- Connecting Android tablets to USB accessories
- Controlling instrumentation from Android devices.
- Home automation via Android devices
- Data logging from USB accessories
- Connecting serial printing devices to Android devices

### 1.1 Part Numbers

Part Number	Package
FT312D-32Q1C-x	32 Pin QFN
FT312D-32L1C-x	32 Pin LQFP

**Note:** Packing codes for x is:

- R: Taped and Reel, QFN 3,000pcs per reel, LQFP 1500 pcs per reel.
- (no suffix): Tray packing, 260pcs per tray QFN, 250 pcs per tray LQFP

For example: FT312D-32Q1C-R is 3,000pcs QFN taped and reel packing

### 1.2 USB Compliant

At the time of writing this datasheet, the FT312D had not completed the USB Compliancy Test.

## 2 FT312D Block Diagram

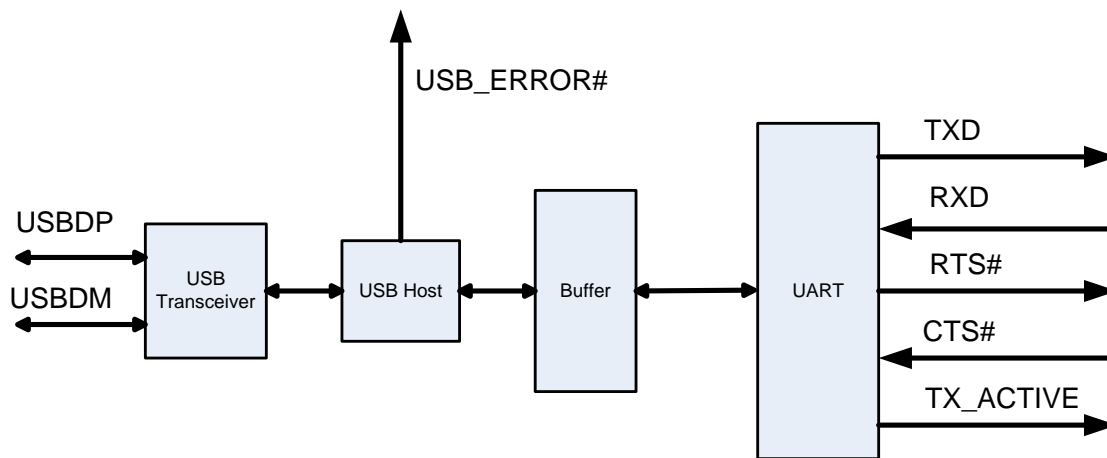

**Figure 2.1 FT312D Block Diagram**

For a description of the function please refer to [Section 4](#).

## Table of Contents

<b>1</b>	<b>Typical Applications.....</b>	<b>2</b>
1.1	Part Numbers.....	2
1.2	USB Compliant .....	2
<b>2</b>	<b>FT312D Block Diagram .....</b>	<b>3</b>
<b>3</b>	<b>Device Pin Out and Signal Description.....</b>	<b>6</b>
3.1	Package Symbol.....	6
3.1.1	Package Pin Out Description .....	6
<b>4</b>	<b>Function Description .....</b>	<b>8</b>
4.1	Key Features.....	8
4.2	Functional Block Descriptions .....	8
4.2.1	UART Interface Module .....	8
4.2.2	Buffers.....	8
4.2.3	USB Host .....	8
4.2.4	USB Transceivers .....	8
4.3	Default Descriptor Strings .....	8
<b>5</b>	<b>UART Interface.....</b>	<b>10</b>
<b>6</b>	<b>USB Error Detection.....</b>	<b>12</b>
<b>7</b>	<b>Absolute Maximum Ratings .....</b>	<b>13</b>
7.1	DC Characteristics.....	13
7.2	ESD and Latch-up Specifications .....	14
<b>8</b>	<b>Application Examples .....</b>	<b>15</b>
8.1	USB to UART Converter .....	15
8.2	USB to RS232 Converter .....	16
<b>9</b>	<b>Package Parameters.....</b>	<b>17</b>
9.1	FT312D Package Markings .....	17
9.1.1	QFN-32.....	17
9.1.2	LQFP-32.....	18
9.2	FT312D Package Dimensions .....	19
9.2.1	QFN-32 Package Dimensions .....	19
9.2.2	LQFP-32 Package Dimensions .....	20
9.3	Solder Reflow Profile .....	20
<b>10</b>	<b>Contact Information .....</b>	<b>22</b>
	<b>Appendix A – References .....</b>	<b>23</b>

<b>Document References .....</b>	<b>23</b>
<b>Useful utilities and examples firmware .....</b>	<b>23</b>
<b>Appendix B - List of Figures and Tables .....</b>	<b>24</b>
<b>List of Figures .....</b>	<b>24</b>
<b>List of Tables.....</b>	<b>24</b>
<b>Appendix C - Revision History .....</b>	<b>25</b>

### 3 Device Pin Out and Signal Description

#### 3.1 Package Symbol

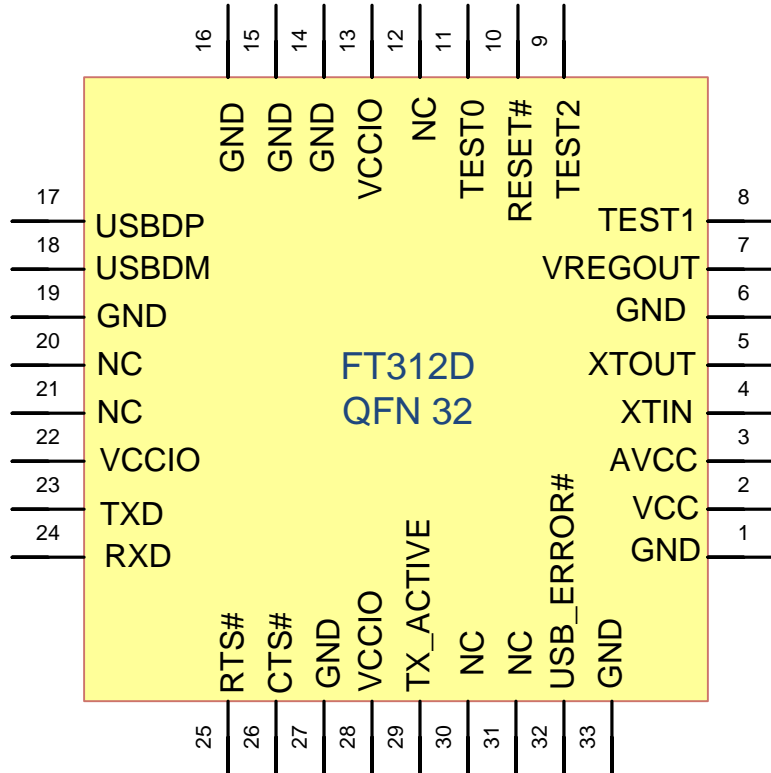

Figure 3.1 QFN Schematic Symbol

**Note 1:** The pinout is the same for the QFN and LQFP packages.

**Note 2:** Pin 33 on the symbol is the copper pad in the centre of the QFN package

##### 3.1.1 Package Pin Out Description

**Note:** # denotes an active low signal.

Pin No.	Name	Type	Description
2	VCC	POWER Input	3V3 supply to IC internal 1V8 regulator
3	AVCC	POWER Input	1V8 supply to IC core
13, 22, 28	VCCIO	POWER Input	3V3 supply for the IO cells
7	VREGOUT	POWER Output	1V8 output. May be used as input source for pin 3.
1,6,14,15,16,19,27	GND	POWER Input	0V Ground input.

Table 3.1 Power and Ground

Pin No.	Name	Type	Description
4	XTIN	INPUT	Input to 12MHz Oscillator Cell. Connect 12MHz crystal across pins 4 and 5.
5	XTOUT	OUTPUT	Output from 12MHz Oscillator Cell. Connect 12MHz crystal across pins 4 and 5.
8	TEST1	INPUT	For internal use. Pull to GND
9	TEST2	INPUT	For factory use. Pull to 3V3.
10	RESET#	INPUT	Reset input (active low).
11	TEST0	OUTPUT	Leave unterminated.
12	NC	-	No connect pins. Leave unterminated.
17	USBDP	INPUT/OUTPUT	USB Data Signal Plus.
18	USBDM	INPUT/OUTPUT	USB Data Signal Minus.
20	NC	-	No connect pins. Leave unterminated.
21	NC	-	No connect pins. Leave unterminated.
23	TXD	OUTPUT	Transmit asynchronous data output
24	RXD	INPUT	Receive asynchronous data input
25	RTS#	OUTPUT	Request to send control output
26	CTS#	INPUT	Clear to send control input
29	TX_ACTIVE	OUTPUT	UART active signal (typically used with RS485)
30	NC	-	No connect pins. Leave un-terminated
31	NC	-	No connect pins. Leave un-terminated
32	USB_ERROR#	OUTPUT	Output signal to indicate a problem with the USB connection

**Table 3.2 Function Pins**

## 4 Function Description

The FT312D is FTDI's second dedicated Android Open Accessory Mode integrated circuit device or Android Host. The FT312D USB host port is dedicated to support of the Android Open Accessory class and will bridge data between this port and the UART interface.

### 4.1 Key Features

Easy to use Android Open Accessory IC translating the Device port of the Android device into UART capabilities.

### 4.2 Functional Block Descriptions

The following paragraphs describe each function within FT312D. Please refer to the block diagram shown in Figure 2.1.

#### 4.2.1 UART Interface Module

The FT312DUART module controls the UART interface providing basic RXD, TXD signalling with RTS#/CTS# hardware flow control. An additional TX\_Active signal is supplied to control external RS485 transceivers for users wishing to create a USB to RS485 bridge. The UART supports baud rates from 300 baud to 921600 baud. A full description of the UART module is provided in [Section 5](#).

#### 4.2.2 Buffers

The FT312D provides internal buffering between the USB port and the UART port of the IC for smooth data streaming.

The Android device can send NAK's to the USB OUT token sent from the FT312D. This can happen when the UART application on the Android is running in the background or multiple applications are launched in the Android device. When the UART application on the Android device is not accepting data, the data will be buffered in the UART RX buffer in FT312D. The UART RX buffer size is 5512 bytes.

The UART\_TX buffer which stores data from the USB port, heading for the UART is 256 bytes.

#### 4.2.3 USB Host

The USB Host block handles the parallel-to-serial and serial-to-parallel conversion of the USB physical layer. This includes bit stuffing, CRC generation.

#### 4.2.4 USB Transceivers

USB transceiver cells provide the physical USB device interface supporting USB 1.1 and USB 2.0 standards. Low-speed and full-speed USB data rates are supported. The output driver provides 3V3 level slew rate control signalling, whilst a differential receiver and two single ended receivers provide USB DATA IN, SE0 and USB Reset condition detection. These cells also include integrated internal pull-down resistors as required for host mode.

## 4.3 Default Descriptor Strings

When the USB port is connected to the Android USB port, the Android platform will determine which application to load based on the strings read from the FT312D. These strings are configurable with a Windows utility: FT312D\_Cofiguration available for download from the [FTDI](#) website. Please refer to the application note [AN\\_236 User Guide for FT312D Configuration](#) to change the default string values.

Default values for the strings are set in the device as per Table 4.1.

<b>Descriptor String</b>	<b>Default Value</b>
Manufacturer	FTDI
Model	Android Accessory FT312D
Version	1.0
Serial	FTDI FT312D
URL	<a href="http://www.ftdichip.com/Android.htm">http://www.ftdichip.com/Android.htm</a>
Description	FTDI Android Accessory FT312D

**Table 4.1 Default Descriptor Strings**

## 5 UART Interface

The interface implements a standard asynchronous serial UART port with flow control, for example RS232/422/485. The UART can support baud rates from 300 to 921600 with RTS/CTS flow control. The UART can support baud rates from 300 to 115200 with no flow control.

Data transfer uses NRZ (Non-Return to Zero) data format consisting of 1 start bit, 7 or 8 data bits, an optional parity bit, and one or two stop bits. When transmitting the data bits, the least significant bit is transmitted first. Transmit and receive waveforms are illustrated in Figure 5-1 and Figure 5-2.

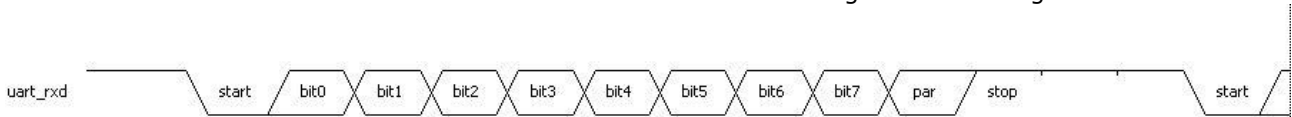

**Figure 5-1 UART Receive Waveform**

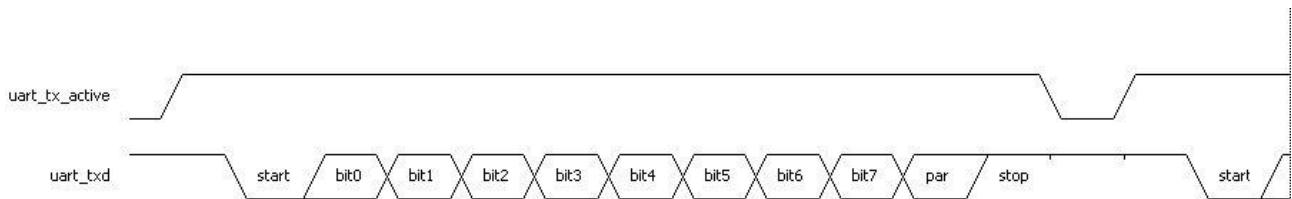

**Figure 5-2 UART Transmit Waveform**

Baud rate (default = 9600 baud), flow control settings (default = None), number of data bits (default = 8), parity (default is no parity) and number of stop bits (default = 1) are all configurable from the Android application. Please refer to [FT31xD Android Programmers Guide](#) for further details.

TX\_ACTIVE is transmit enable, this output may be used in RS485 designs to enable the line driver for transmit mode.

UART RX buffer size is 5512 bytes and UART TX buffer size is 256 bytes.

**Note:** UART software flow control with XON/XOFF is not supported  
 UART hardware flow control with DTR/DSR is not supported

**Note:**

The FT312D has to enumerate the Android device before receiving data from the UART device.

This can be implemented by disconnecting the UART TXD signal of external UART device connected to the FT312D RXD signal until after the FT312D has established the USB link with Android device.

The connection sequence should be:

1. Connect FT312D to Android and complete enumeration.
2. Connect the TXD of UART device to FT312D's RXD then start to receive data.

There are two methods to implement this function:

1. When FT312D connects to the Android device and enumeration is completed, the USB\_ERROR# will become Logic 0 (default Logic 1). This signal can be used to control the TTL gate (74LVC2G241, 74LVC1G125 or others) ON/OFF such that the TXD/RXD lines are connected/disconnected.

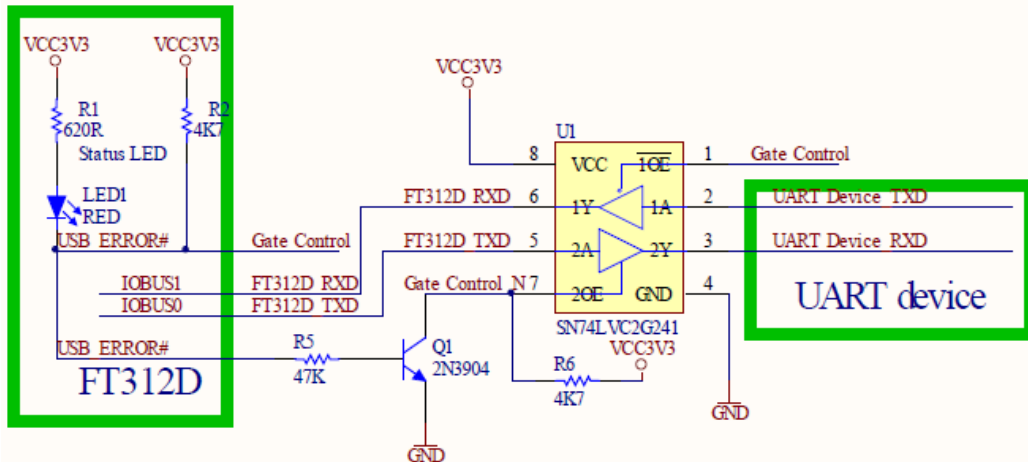

**Figure 5-3 UART RXD and TXD connection gated by Enumeration**

If the UART device has an enable pin (active high enable) such as on the GPS module, the USB\_ERROR# can also be used. The USB\_ERROR# pin may be inverted with an NPN BJT then connected to the enable pin of the GPS module.

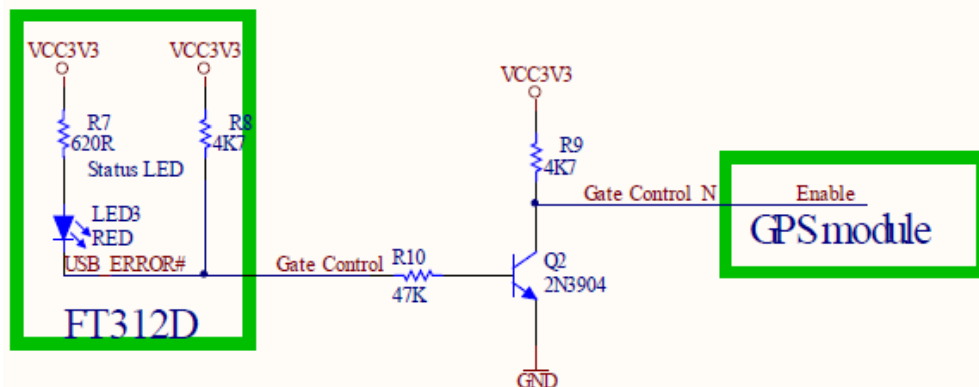

**Figure 5-4 Inverting Gate Control signal to enable GPS module (active high enable)**

## 6 USB Error Detection

Pin 32 of the device is provided to indicate a problem has occurred with the USB connection. The errors are USB device not supported, USB hub not supported and USB device not responding. USB device not supported would occur if the USB port was connected to a non-Android class device port. E.g. The FT312D is not designed to host memory sticks or printers etc. USB hub not supported would be reported if FT312D is connected to a USB hub. USB device not responding would occur if the USB device connected to the FT312D host port did not respond and the enumeration failed. The signal states are as follows:

Pin state	Definition
Logic 0	Device connected to USB and functional
Logic 1	Device not connected
One 50ms logic 0 pulse	Device not responding. This pulse occurs at plug-in and then the signal returns to logic 1. This then repeats every second.
Two 50ms logic 0 pulses	Device not supported. These pulses occur at plug-in and then the signal returns to logic 1. This then repeats every second.
Three 50ms logic 0 pulses	Hub not supported. These pulses occur at plug-in and then the signal returns to logic 1. This then repeats every second.

**Table 6.1 Error Detection**

## 7 Absolute Maximum Ratings

The absolute maximum ratings for FT312D are shown in Table 7.1. These are in accordance with the Absolute Maximum Rating System (IEC 60134). Exceeding these may cause permanent damage to the device.

Parameter	Value	Unit
Storage Temperature	-65°C to 150°C	Degrees C
Floor Life (Out of Bag) At Factory Ambient ( 30°C / 60% Relative Humidity)	168 Hours (IPC/JEDEC J-STD-033A MSL Level 3 Compliant)*	Hours
Ambient Temperature (Power Applied)	-40°C to 85°C	Degrees C.
Vcc Supply Voltage	0 to +3.63	V
VCCIO	0 to +3.63	V
AVCC	0 to + 1.98	V
DC Input Voltage - USBDP and USBDM	-0.5 to +(Vcc +0.5)	V
DC Input Voltage - High Impedance Bidirectional	-0.5 to +5.00	V
DC Input Voltage - All other Inputs	-0.5 to +(Vcc +0.5)	V
DC Output Current - Outputs	4	mA
DC Output Current - Low Impedance Bidirectional	4	mA

**Table 7.1 Absolute Maximum Ratings**

\* If devices are stored out of the packaging beyond this time limit the devices should be baked before use. The devices should be ramped up to a temperature of 125°C and baked for up to 17 hours.

### 7.1 DC Characteristics

DC Characteristics (Ambient Temperature -40°C to +125°C)

Parameter	Description	Minimum	Typical	Maximum	Units	Conditions
Vcc1	VCC Operating Supply Voltage	2.97	3.3	3.63	V	
Vcc2	VCCIO Operating Supply Voltage	2.97	3.3	3.63	V	
AVCC	VCC_PLL Operating Supply Voltage	1.62	1.8	1.98	V	
Icc1	Operating Supply Current 48MHz		25		mA	Normal Operation
Icc2	Operating Supply Current		128		µA	USB Suspend

**Table 7.2 Operating Voltage and Current**

Parameter	Description	Minimum	Typical	Maximum	Units	Conditions
Voh	Output Voltage High	2.4			V	I source = 8mA
Vol	Output Voltage Low			0.4	V	I sink = 8mA
Vin	Input Switching Threshold		1.5		V	

**Table 7.3 I/O Pin Characteristics**

Parameter	Description	Minimum	Typical	Maximum	Units	Conditions
UVoh	I/O Pins Static Output ( High)	2.8			V	
UVol	I/O Pins Static Output ( Low )			0.3	V	
UVse	Single Ended Rx Threshold	0.8		2.0	V	

Parameter	Description	Minimum	Typical	Maximum	Units	Conditions
UCom	Differential Common Mode	0.8		2.5	V	
UVdif	Differential Input Sensitivity	0.2			V	
UDrvZ	Driver Output Impedance	3	6	9	Ohms	

**Table 7.4 USB I/O Pin (USBDP, USBDM) Characteristics**

Parameter	Description	Minimum	Typical	Maximum	Units	Conditions
VCKK	Power supply of internal core cells and I/O to core interface	1.62	1.8	1.98	V	1.8V power supply
VCC18IO	Power supply of 1.8V OSC pad	1.62	1.8	1.98	V	1.8V power supply
T <sub>J</sub>	Operating junction temperature	-40	25	125	°C	
I <sub>in</sub>	Input leakage current	-10	±1	10	µA	I <sub>in</sub> = VCC18IO or 0V
I <sub>oz</sub>	Tri-state output leakage current	-10	±1	10	µA	

**Table 7.5 Crystal Oscillator 1.8 Volts DC Characteristics**

## 7.2 ESD and Latch-up Specifications

Description	Specification
<b>Human Body Mode (HBM)</b>	± 2000V
<b>Machine mode (MM)</b>	± 200V
<b>Charged Device Mode (CDM)</b>	± 500V
<b>Latch-up</b>	> ± 200mA

**Table 7.6 ESD and Latch-up Specifications**

## 8 Application Examples

The following sections illustrate possible applications of the FT312D.

### 8.1 USB to UART Converter

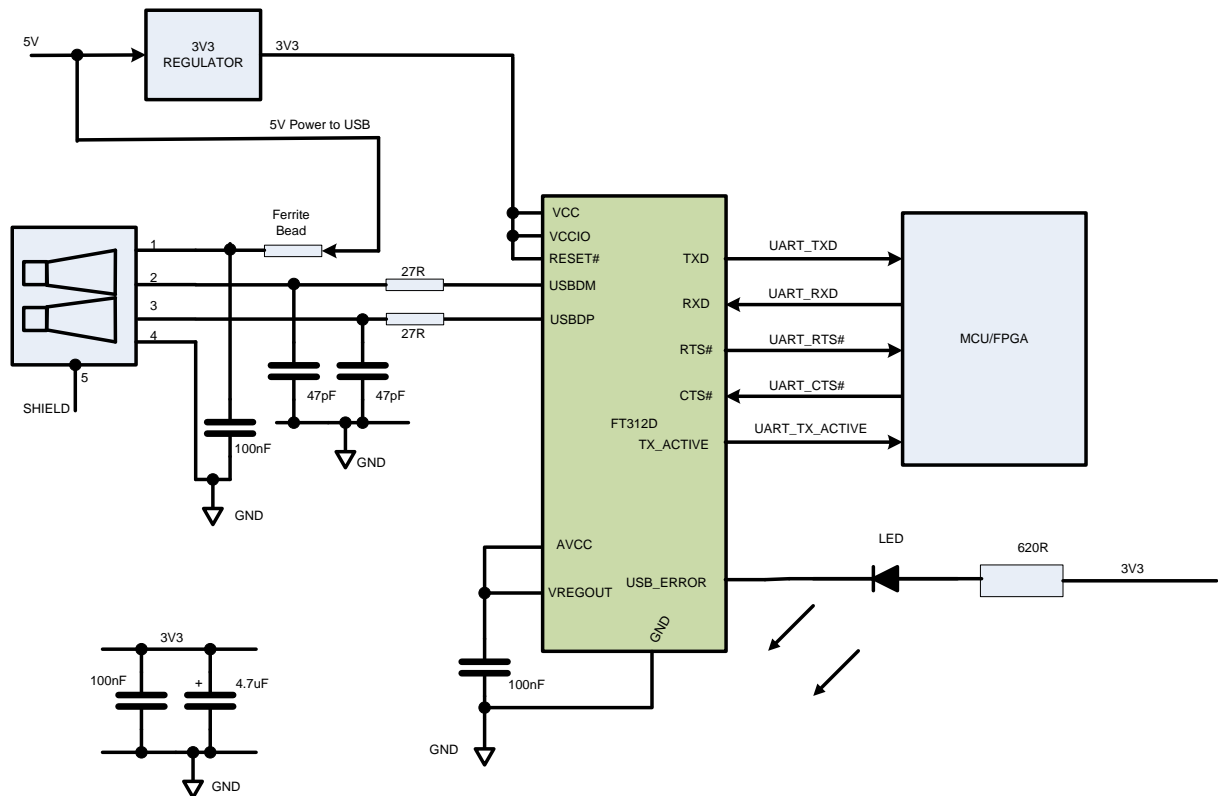
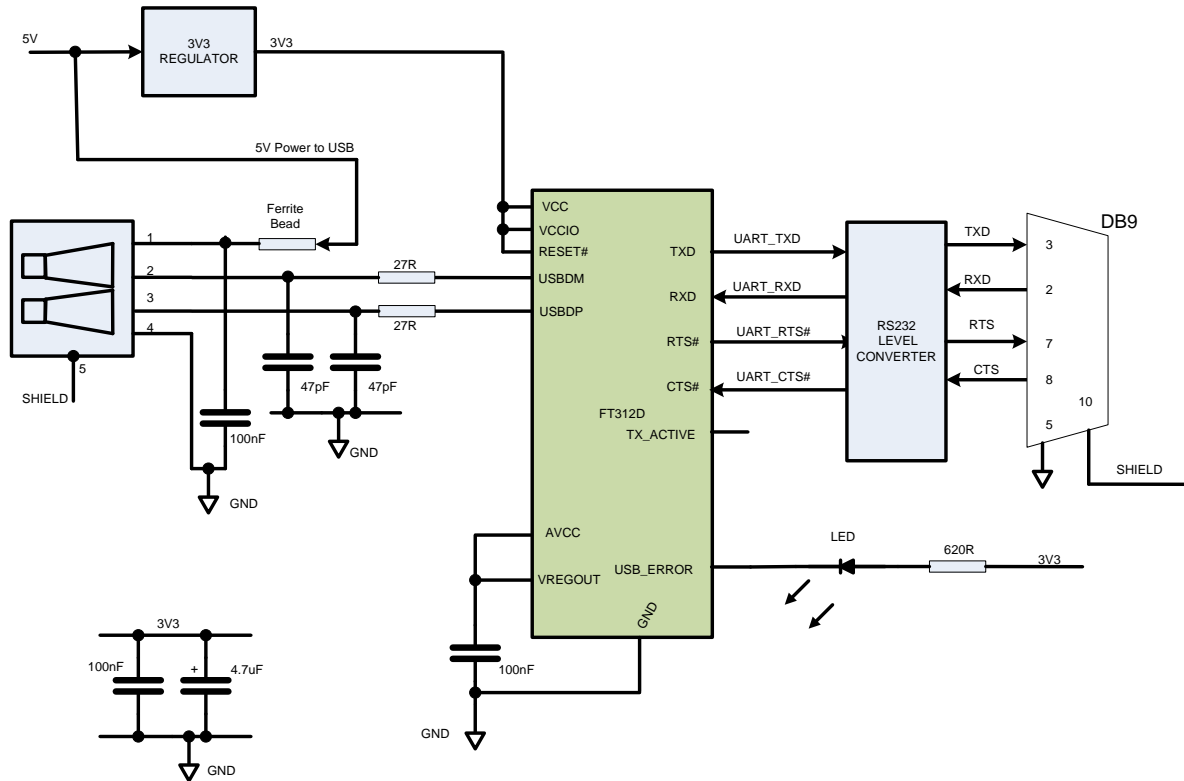

**Figure 8.1 Application Example showing USB to UART Converter**

The UART signals are at 3V3 level and may be used to drive directly into a FPGA or MCU with a 3V3 interface, or could be level shifted with an RS232, RS422 or RS485 transceiver. The TX\_ACTIVE signal is used mostly with RS485 transceivers to enable the Transmit line drivers.

The unused pins may be left unterminated.

## 8.2 USB to RS232 Converter



**Figure 8.2 Application Example showing USB to RS232 Converter**

An example of using the FT312D as a USB to RS232 converter is illustrated in Figure 8.2. In this application, a TTL to RS232 Level Converter IC is used on the serial UART interface of the FT312D to convert the TTL levels of the FT312D to RS232 levels. This level shift can be done using line drivers from a variety of vendors e.g. Zywyn.

A suitable level shifting device is the Zywyn ZT3243F which is capable of RS232 communication at up to 1000k baud.

The unused pins may be left unterminated.

## 9 Package Parameters

FT312D is available in RoHS Compliant packages, QFN package (32QFN) and an LQFP package (32LQFP). The packages are lead (Pb) free and use a 'green' compound. The package is fully compliant with European Union directive 2002/95/EC.

The mechanical drawings of the packages are shown in Sections 9.2 - all dimensions are in millimetres.

The solder reflow profile for all packages can be viewed in Section 9.3.

### 9.1 FT312D Package Markings

#### 9.1.1 QFN-32

An example of the markings on the QFN package are shown in Figure 9-1. The FTDI part number is too long for the 32 QFN package so in this case the last two digits are wrapped down onto the date code line.

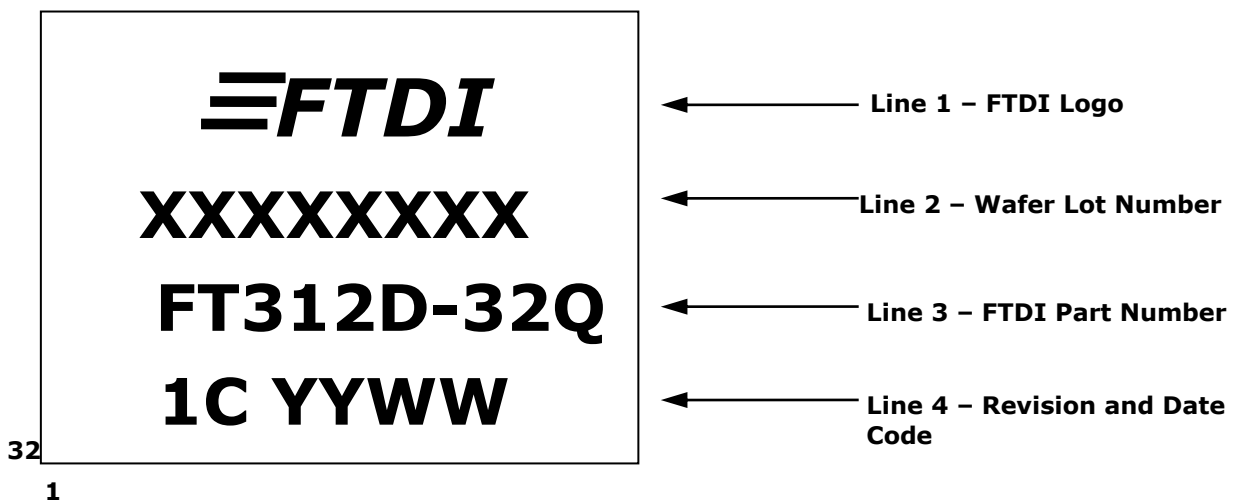

**Figure 9-1QFN Package Markings**

1C should be printed on line 4, then a space and then the Date Code.

1. YYWW = Date Code, where YY is year and WW is week number
2. Marking alignment should be centre justified
3. Laser Marking should be used
4. All marking dimensions should be marked proportionally. Marking font should be using Unisem standard font (Roman Simplex)

### 9.1.2 LQFP-32

An example of the markings on the LQFP package are shown in Figure 9-2.

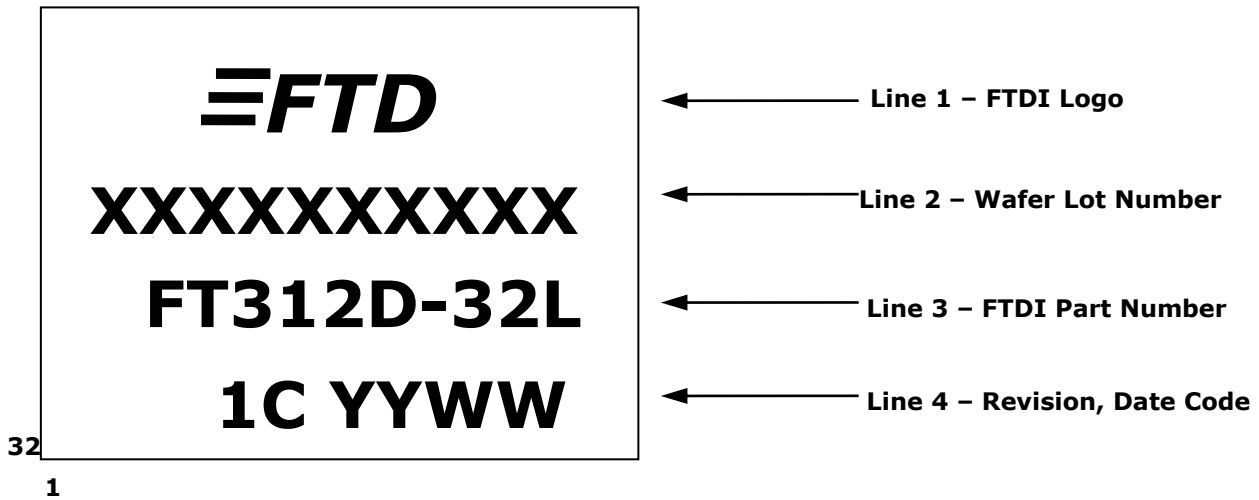

**Figure 9-2 LQFP Package Markings**

**Notes:**

1. YYWW = Date Code, where YY is year and WW is week number
2. Marking alignment should be centre justified
3. Laser Marking should be used
4. All marking dimensions should be marked proportionally. Marking font should be using Unisem standard font (Roman Simplex)

## 9.2 FT312D Package Dimensions

### 9.2.1 QFN-32 Package Dimensions

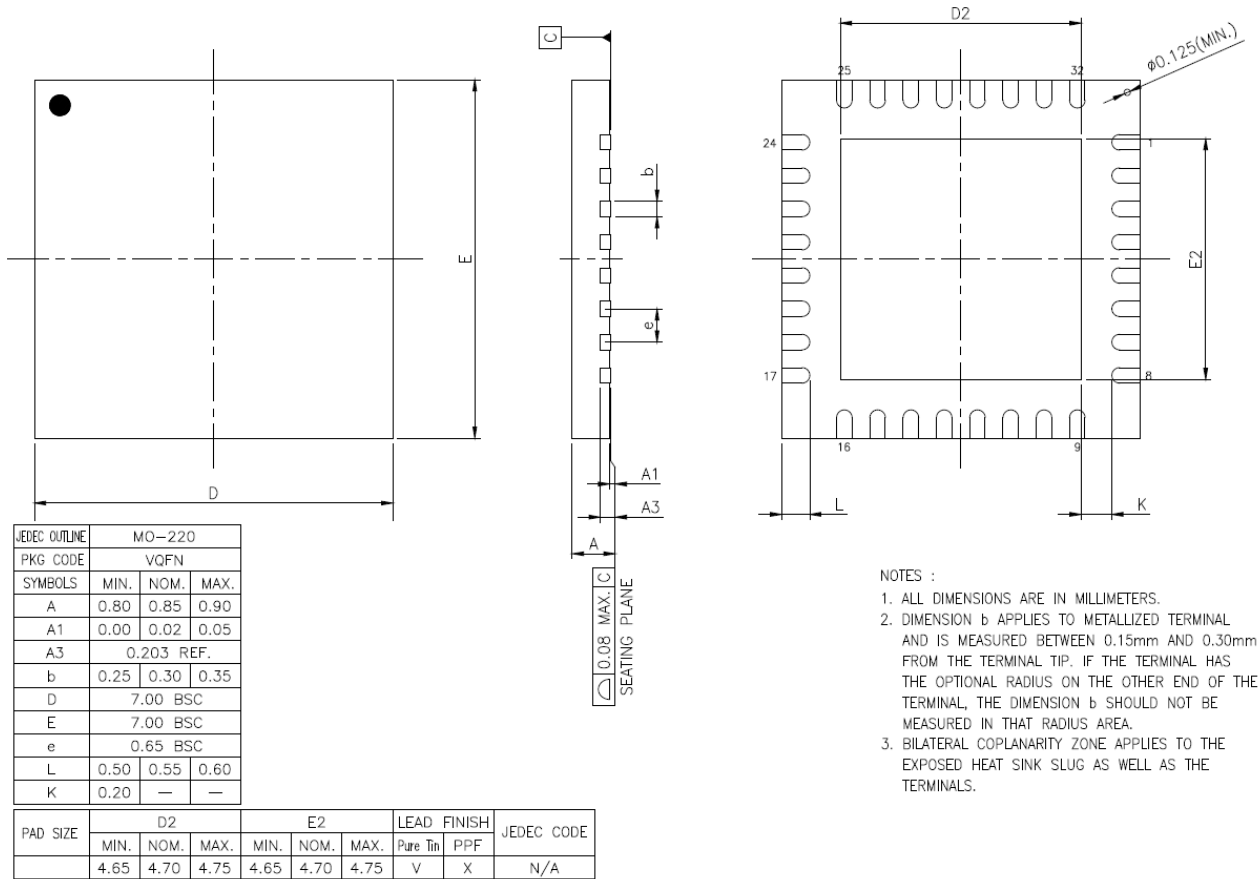

- NOTES :
1. ALL DIMENSIONS ARE IN MILLIMETERS.
  2. DIMENSION b APPLIES TO METALLIZED TERMINAL AND IS MEASURED BETWEEN 0.15mm AND 0.30mm FROM THE TERMINAL TIP. IF THE TERMINAL HAS THE OPTIONAL RADIUS ON THE OTHER END OF THE TERMINAL, THE DIMENSION b SHOULD NOT BE MEASURED IN THAT RADIUS AREA.
  3. BILATERAL COPLANARITY ZONE APPLIES TO THE EXPOSED HEAT SINK SLUG AS WELL AS THE TERMINALS.

Figure 9-3 QFN-32 Package Dimensions

**Note 1:** Dimensions are in mm

**Note 2:** The centre pad should be connected to the GND plane for improved thermal conduction and noise immunity.

### 9.2.2 LQFP-32 Package Dimensions

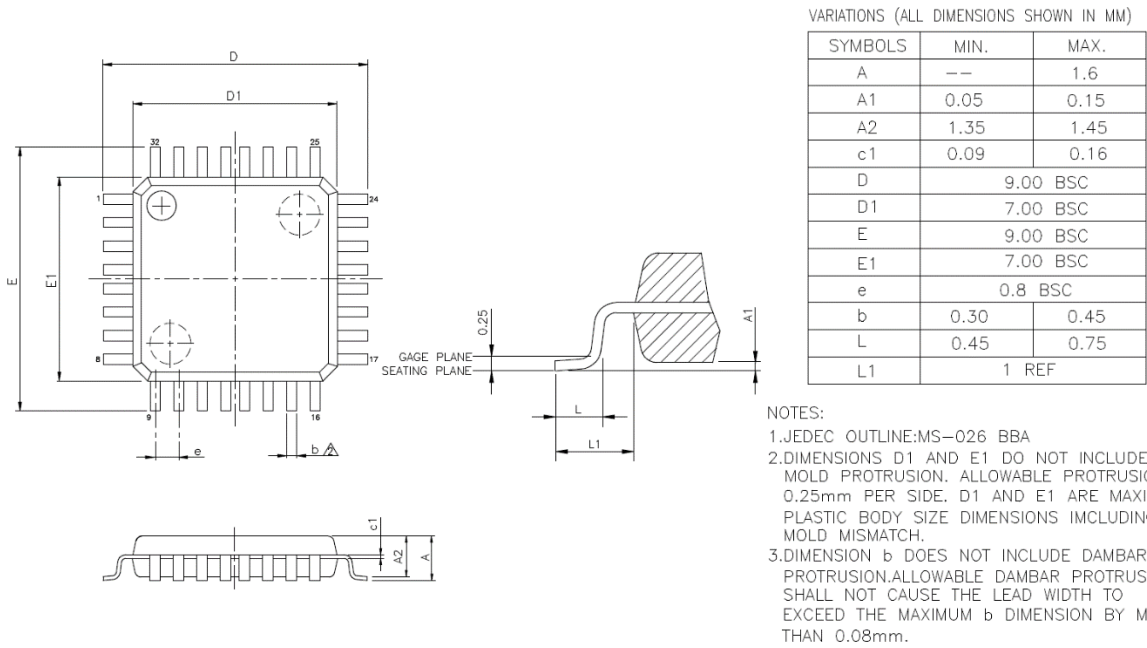

Figure 9-4 LQFP-32 Package Dimensions

**Note:** Dimensions are in mm

### 9.3 Solder Reflow Profile

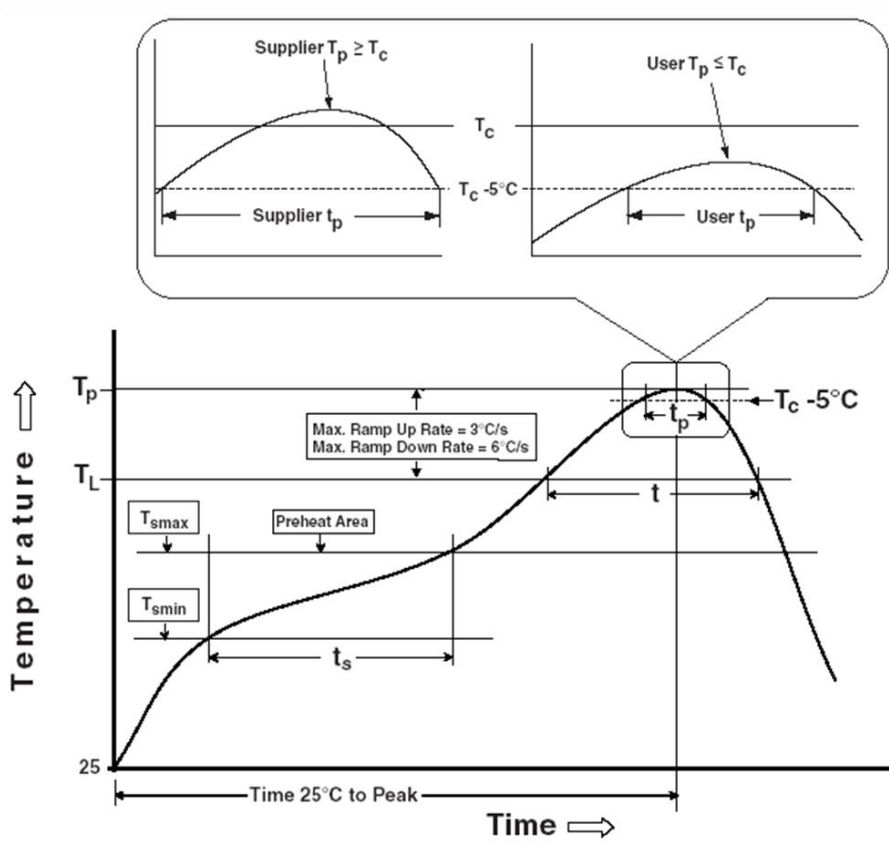

Figure 9-5 All packages Reflow Solder Profile

<b>Profile Feature</b>	<b>Pb Free Solder Process (green material)</b>	<b>SnPb Eutectic and Pb free (non green material) Solder Process</b>
Average Ramp Up Rate ( $T_s$ to $T_p$ )	3°C / second Max.	3°C / Second Max.
Preheat - Temperature Min ( $T_s$ Min.) - Temperature Max ( $T_s$ Max.) - Time ( $t_s$ Min to $t_s$ Max)	150°C 200°C 60 to 120 seconds	100°C 150°C 60 to 120 seconds
Time Maintained Above Critical Temperature $T_L$ : - Temperature ( $T_L$ ) - Time ( $t_L$ )	217°C 60 to 150 seconds	183°C 60 to 150 seconds
Peak Temperature ( $T_p$ )	260°C	see Figure 9-5
Time within 5°C of actual Peak Temperature ( $t_p$ )	30 to 40 seconds	20 to 40 seconds
Ramp Down Rate	6°C / second Max.	6°C / second Max.
Time for $T = 25^\circ\text{C}$ to Peak Temperature, $T_p$	8 minutes Max.	6 minutes Max.

**Table 9.1 Reflow Profile Parameter Values**

<b>SnPb Eutectic and Pb free (non green material)</b>		
Package Thickness	Volume mm <sup>3</sup> < 350	Volume mm <sup>3</sup> ≥ 350
< 2.5 mm	235 +5/-0 deg C	220 +5/-0 deg C
≥ 2.5 mm	220 +5/-0 deg C	220 +5/-0 deg C
<b>Pb Free (green material) = 260 +5/-0 deg C</b>		

**Table 9.2 Package Reflow Peak Temperature**

## 10 Contact Information

### Head Office – Glasgow, UK

Future Technology Devices International Limited  
Unit 1, 2 Seaward Place, Centurion Business Park  
Glasgow G41 1HH  
United Kingdom  
Tel: +44 (0) 141 429 2777  
Fax: +44 (0) 141 429 2758

E-mail (Sales) [sales1@ftdichip.com](mailto:sales1@ftdichip.com)  
E-mail (Support) [support1@ftdichip.com](mailto:support1@ftdichip.com)  
E-mail (General Enquiries) [admin1@ftdichip.com](mailto:admin1@ftdichip.com)

### Branch Office – Taipei, Taiwan

Future Technology Devices International Limited  
(Taiwan)  
2F, No. 516, Sec. 1, NeiHu Road  
Taipei 114  
Taiwan, R.O.C.  
Tel: +886 (0) 2 8791 3570  
Fax: +886 (0) 2 8791 3576

E-mail (Sales) [tw.sales1@ftdichip.com](mailto:tw.sales1@ftdichip.com)  
E-mail (Support) [tw.support1@ftdichip.com](mailto:tw.support1@ftdichip.com)  
E-mail (General Enquiries) [tw.admin1@ftdichip.com](mailto:tw.admin1@ftdichip.com)

### Branch Office – Oregon, USA

Future Technology Devices International Limited (USA)  
7130 SW Fir Loop  
Tigard, OR 97223  
USA  
Tel: +1 (503) 547 0988  
Fax: +1 (503) 547 0987

E-Mail (Sales) [us.sales@ftdichip.com](mailto:us.sales@ftdichip.com)  
E-Mail (Support) [us.support@ftdichip.com](mailto:us.support@ftdichip.com)  
E-Mail (General Enquiries) [us.admin@ftdichip.com](mailto:us.admin@ftdichip.com)

### Branch Office – Shanghai, China

Room 1103, No. 666 West Huaihai Road,  
Shanghai, 200052  
China  
Tel: +86 21 62351596  
Fax: +86 21 62351595

E-mail (Sales) [cn.sales@ftdichip.com](mailto:cn.sales@ftdichip.com)  
[cn.support@ftdichip.com](mailto:cn.support@ftdichip.com)  
E-mail (Support) [cn.admin@ftdichip.com](mailto:cn.admin@ftdichip.com)  
E-mail (General Enquiries)

## **Appendix A – References**

### **Document References**

[WP 001 Connecting Peripherals to an Android Platform](#)

[FT31XD Android Programmers Guide](#)

### **Useful utilities and examples firmware**

[http://www.ftdichip.com/Support/Utilities/FT312D\\_Configuration\\_V010000.zip](http://www.ftdichip.com/Support/Utilities/FT312D_Configuration_V010000.zip)

[http://www.ftdichip.com/Support/SoftwareExamples/Android\\_Projects.htm](http://www.ftdichip.com/Support/SoftwareExamples/Android_Projects.htm)

## **Appendix B - List of Figures and Tables**

### **List of Figures**

Figure 2.1 FT312D Block Diagram .....	3
Figure 3.1 QFN Schematic Symbol .....	6
Figure 5-1 UART Receive Waveform .....	10
Figure 5-2 UART Transmit Waveform .....	10
Figure 5-3 UART RXD and TXD connection gated by Enumeration .....	11
Figure 5-4 Inverting Gate Control signal to enable GPS module (active high enable) .....	11
Figure 8.1 Application Example showing USB to UART Converter .....	15
Figure 8.2 Application Example showing USB to RS232 Converter .....	16
Figure 9-1 QFN Package Markings .....	17
Figure 9-2 LQFP Package Markings .....	18
Figure 9-3 QFN-32 Package Dimensions .....	19
Figure 9-4 LQFP-32 Package Dimensions .....	20
Figure 9-5 All packages Reflow Solder Profile .....	20

### **List of Tables**

Table 3.1 Power and Ground .....	6
Table 3.2 Function Pins .....	7
Table 4.1 Default Descriptor Strings .....	9
Table 6.1 Error Detection .....	12
Table 7.1 Absolute Maximum Ratings .....	13
Table 7.2 Operating Voltage and Current .....	13
Table 7.3 I/O Pin Characteristics .....	13
Table 7.4 USB I/O Pin (USBDP, USBDM) Characteristics .....	14
Table 7.5 Crystal Oscillator 1.8 Volts DC Characteristics .....	14
Table 7.6 ESD and Latch-up Specifications .....	14
Table 9.1 Reflow Profile Parameter Values .....	21
Table 9.2 Package Reflow Peak Temperature .....	21

## Appendix C - Revision History

Document Title: USB Android Host IC DS\_FT312D  
Document Reference No.: FT\_000816  
Clearance No.: FTDI# 331  
Product Page: <http://www.ftdichip.com/FTProducts.htm>  
Document Feedback: [Send Feedback](#)

Revision	Changes	Date
Version 1.0	Initial Datasheet Created	2013-02-01
Version 1.1	Note added on USB enumeration to be completed before receiving data in RXD	2013-11-15
Version 1.2	Updated Figure 9-3 and Figure 9-4 package dimensions	2019-05-27

## Looking for pricing, stock, or lifecycle information?

Click below to explore more details on WIN SOURCE:

- [View FT312D-32Q1C-T on WIN SOURCE](#)
- [FTDI, Future Technology Devices International Ltd Information](#)

## Optimize Your Supply Chain with WIN SOURCE Solutions

- ✓ Global Sourcing Solution
- ✓ Obsolete Management
- ✓ Cost Control Management
- ✓ Shortage Management
- ✓ Alternative Solution
- ✓ Excess Inventory Management