



THE DATASHEET OF TPS2595EVM



TPS2595EVM: Evaluation Module for TPS2595xx

This user's guide describes the evaluation module (EVM) for the TPS2595xx family of eFuse devices. The TPS2595xx devices are simple, fully-integrated eFuse protection switches with overvoltage protection in a tiny 2-mm × 2-mm package.

Contents

1	Introduction	2
	1.1 EVM Features	2
	1.2 EVM Applications	2
2	Description	2
3	Schematic and Bill of Materials	3
4	General Configurations	4
	4.1 Physical Access	4
	4.2 Test Equipment and Set Up	6
5	Test Setup and Procedures	7
	5.1 Inrush Current Test	8
	5.2 Current-Limit Test	8
	5.3 Wakeup at Output Short Test	9
	5.4 Overvoltage Clamp Test	9
6	Evaluation Board Assembly Drawings and Layout Guidelines	10
	6.1 PCB Drawings	10
7	Bill Of Materials (BOM)	11

List of Figures

1	TPS2595EVM eFuse Evaluation Board Schematic	3
2	TPS2595EVM Setup With Test Equipment	7
3	TPS259541 Output Rise Profile ($V_{IN} = 12\text{ V}$, $C_{dVdT} = 10\text{ nF}$, $C_{OUT} = 100\text{ }\mu\text{F}$, No-Load)	8
4	TPS259541 Overcurrent Response for 2-A Current-Limit Setting (14 Ω to 4 Ω)	8
5	Test Waveform of Wakeup at Output Short for TPS259541 Device	9
6	TPS259541 Overvoltage Clamp Response When V_{IN} is Increased From 12 V to 16 V	9
7	TPS2595EVM Board Top Assembly	10
8	Top Layer	10
9	Bottom Layer	10

List of Tables

1	TPS2595EVM eFuse Evaluation Board Options and Settings	2
2	Input and Output Connector Functionality	4
3	Test Points Description	4
4	Jumper and LED Descriptions	5
5	Default Jumper Setting for TPS2595EVM eFuse Evaluation Board	7
6	TPS2595EVM Bill Of Materials	11

Trademarks

All trademarks are the property of their respective owners.

1 Introduction

The *TPS2595EVM eFuse Evaluation Board* allows reference circuit evaluation of TI's TPS259520, TPS259533, TPS259541, and TPS259573 devices.

NOTE: To evaluate other variants from the TPS2595xx family, please order the samples from www.ti.com separately, and replace existing devices on the EVM as per [Table 1](#).

1.1 EVM Features

General TPS2595EVM eFuse evaluation board features include:

- 2.7-V to 18-V (TYP) operation
- 0.5-A to 4-A programmable load current limit
- Programmable V_{OUT} slew rate control
- Onboard TVS for input transient protection
- Common diode at output prevents negative spike when load is removed
- Overvoltage clamp and cutoff

1.2 EVM Applications

This EVM can be used on the following applications:

- Hot-swap, hot-plug
- SSDs and HDDs
- Industrial systems
- White goods
- Set-top box
- Digital TV

2 Description

The TPS2595EVM eFuse evaluation board enables evaluation of four variant devices (through four channels) from the TPS2595xx family. The input power port is common for all the four channels and is applied at T1 and the corresponding outputs are labeled as VOUT1, VOUT2, VOUT3, and VOUT4 at T2 which provides the output connection to the load, Refer to the schematic in [Figure 1](#), and the EVM test setup in [Figure 2](#). D2, C1 at T1 provides input protection for all four channels.

Table 1. TPS2595EVM eFuse Evaluation Board Options and Settings

EVM Function	Channel	V_{IN} Range	OV Clamp	Enable (EN or UVLO)	Current Limit		Fault Response	Options for Other Variant Evaluation
					Lo Setting	Hi Setting		
2.7 V to 18 V, 4-A eFuse	CH1 – TPS259520	2.7 V–18 V	3.8 V	Active High	0.5 A	4 A	Latch-off	TPS259521, TPS259525, TPS259530, TPS259531, and TPS259535 can be evaluated on CH1
	CH2 – TPS259533		5.7 V	Active Low			Auto-retry	–
	CH3 – TPS259541		13.8 V	Active High				TPS259540, TPS259570, and TPS259571 can be evaluated on CH3
	CH4 – TPS259573		OV cutoff at 15 V	Active Low				–

3 Schematic and Bill of Materials

Figure 1 illustrates the EVM schematic.

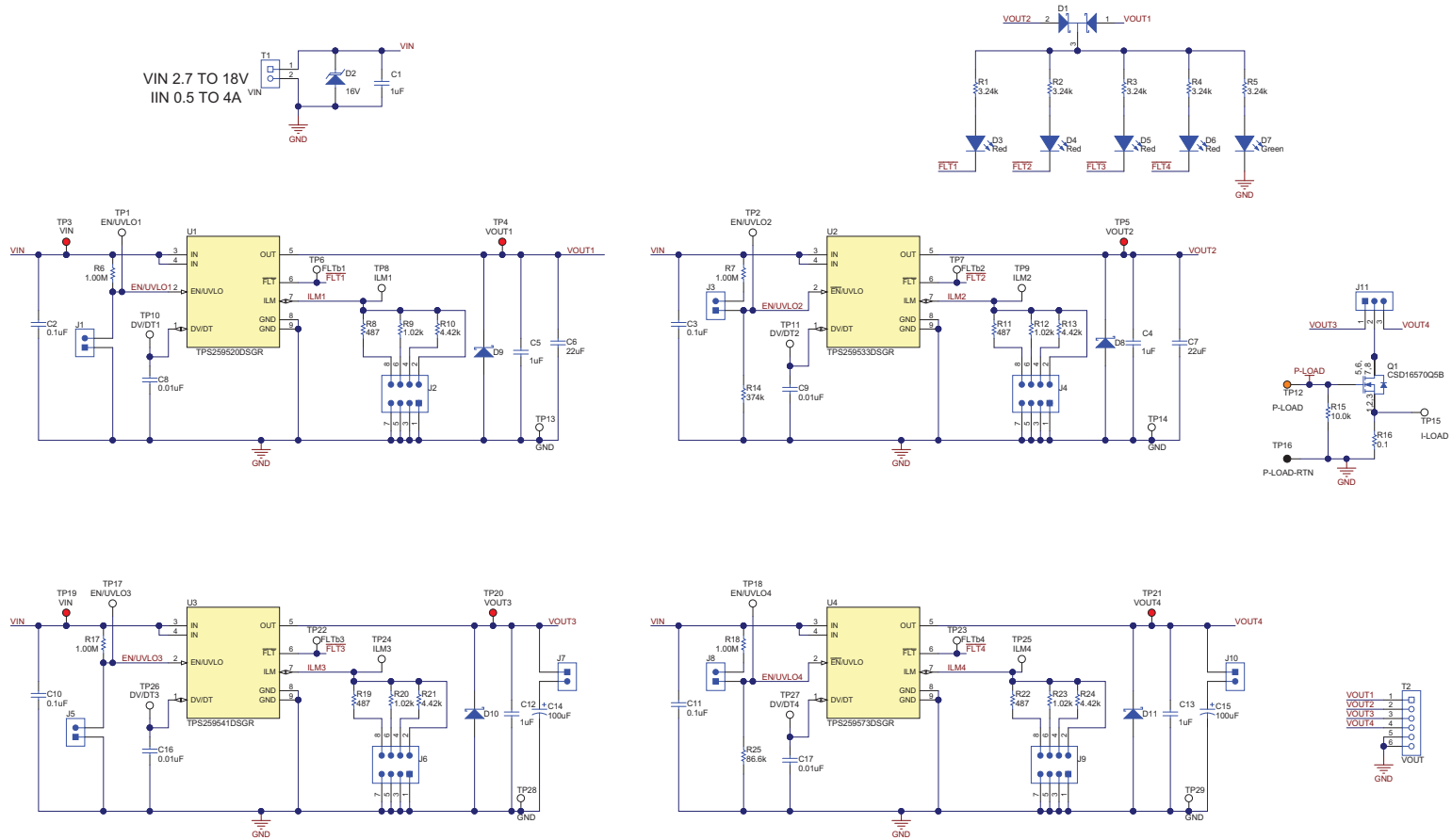

Copyright © 2017, Texas Instruments Incorporated

Figure 1. TPS2595EVM eFuse Evaluation Board Schematic

4 General Configurations

4.1 Physical Access

Table 2 lists the TPS2595EVM eFuse evaluation board input and output connector functionality. Table 3 describes the test point availability and Table 4 describes the jumper functionality and LED descriptions.

Table 2. Input and Output Connector Functionality

Connector		Label	Description
T1	CH1, CH2, CH3, CH4	VIN(+), GND(-)	Common input for all the four channels
T2	CH1	VOUT1(+), GND(-)	Output of CH1
	CH2	VOUT2(+), GND(-)	Output of CH2
	CH3	VOUT3(+), GND(-)	Output of CH3
	CH4	VOUT4(+), GND(-)	Output of CH4

Table 3. Test Points Description

Channel	Test Points	Label	Description
CH1	TP3	VIN	Input voltage to the board
	TP1	EN/UVLO1	CH1 EN/UVLO setting
	TP10	DV/DT1	CH1 output voltage ramp control
	TP6	FLTb1	CH1 fault indicator
	TP8	ILM1	CH1 load current monitor
	TP4	VOUT1	CH1 output voltage
	TP13	GND	GND
CH2	TP2	EN/UVLO2	CH2 EN/UVLO setting
	TP11	DV/DT2	CH2 output voltage ramp control
	TP7	FLTb2	CH2 fault indicator
	TP9	ILM2	CH2 load current monitor
	TP5	VOUT2	CH2 output voltage
	TP14	GND	GND
CH3	TP19	VIN	Input voltage to the board
	TP17	EN/UVLO3	CH3 EN/UVLO setting
	TP26	DV/DT3	CH3 output voltage ramp control
	TP22	FLTb3	CH3 fault indicator
	TP24	ILM3	CH3 load current monitor
	TP20	VOUT3	CH3 output voltage
	TP28	GND	GND
CH4	TP18	EN/UVLO4	CH4 EN/UVLO setting
	TP27	DV/DT4	CH4 output voltage ramp control
	TP23	FLTb4	CH4 fault indicator
	TP25	ILM4	CH4 load current monitor
	TP21	VOUT4	CH4 output voltage
	TP29	GND	GND
	TP12	P-LOAD	Pulsed load ENABLE
	TP15	I-LOAD	Pulsed load test point
TP16	P-LOAD-RTN	Pulsed load return	

Table 4. Jumper and LED Descriptions

Jumper	Label	Description
J1	EN/UVLO1	CH1 EN setting Install J1 to disable CH1
J2	ILM1	CH1 current-limit setting 1-2 position sets Rlim to short 3-4 Position sets 0.5 A 5-6 Position sets 2 A 7-8 Position sets 4 A
J3	EN/UVLO2	CH2 OVP setting Install J3 to set OVP
J4	ILM2	CH2 current-limit setting 1-2 position sets Rlim to short 3-4 position sets 0.5 A 5-6 position sets 2 A 7-8 position sets 4 A
J5	EN/UVLO3	CH3 EN setting Install J1 to disable CH3
J6	ILM3	CH3 current-limit setting 1-2 position sets Rlim to short 3-4 position sets 0.5 A 5-6 position sets 2 A 7-8 position sets 4 A
J7	Capacitor at VOUT3	CH3 output capacitor setting Install J7 to add 100 μ F at VOUT3
J8	EN/UVLO4	CH4 OVP setting Install J8 to set OVP
J9	ILM4	CH4 current-limit setting 1-2 Position sets Rlim to short 3-4 position sets 0.5 A 5-6 position sets 2 A 7-8 position sets 4 A
J10	Capacitor at VOUT4	CH4 output capacitor setting Install J10 to add 100 μ F at VOUT4
J11	Short test at VOUT3 or VOUT4	Enables ON board output short circuit test 1-2 position connects VOUT3 to Short-FET 3-4 Position connects VOUT4 to Short-FET
D3, D4, D5, D6 (RED – LED)	Fault indicator	CH1, CH2, CH3, CH4 fault indicators
D7 (GREEN – LED)	Output power indicator	CH1 and CH2 output power indicator. LED turns on whenever the output voltage is available at CH1 or CH2.

4.2 Test Equipment and Set Up

The following sections describe the equipment and set up to test the EVM.

4.2.1 Power Supplies

One adjustable power supply 0 V to 18 V output, 0 A to 5 A output current limit.

4.2.2 Meters

One DMM, minimum, needed.

4.2.3 Oscilloscope

A DPO2024 or equivalent, three 10x voltage probes, and a DC-current probe.

4.2.4 Loads

One resistive load or equivalent which can tolerate up to 5-A DC load at 12 V, and capable of the output short.

5 Test Setup and Procedures

In this user guide, the test procedure is described for the TPS259541 device on CH3. Following similar test steps, the other devices can also be evaluated.

Make sure the evaluation board has default jumper settings as shown in [Table 5](#).

Table 5. Default Jumper Setting for TPS2595EVM eFuse Evaluation Board

CH1		CH2		CH3			CH4			
J1	J2	J3	J4	J5	J6	J7	J8	J9	J10	J11
Open	5-6	Open	5-6	Open	5-6	Install	Open	5-6	Install	Open

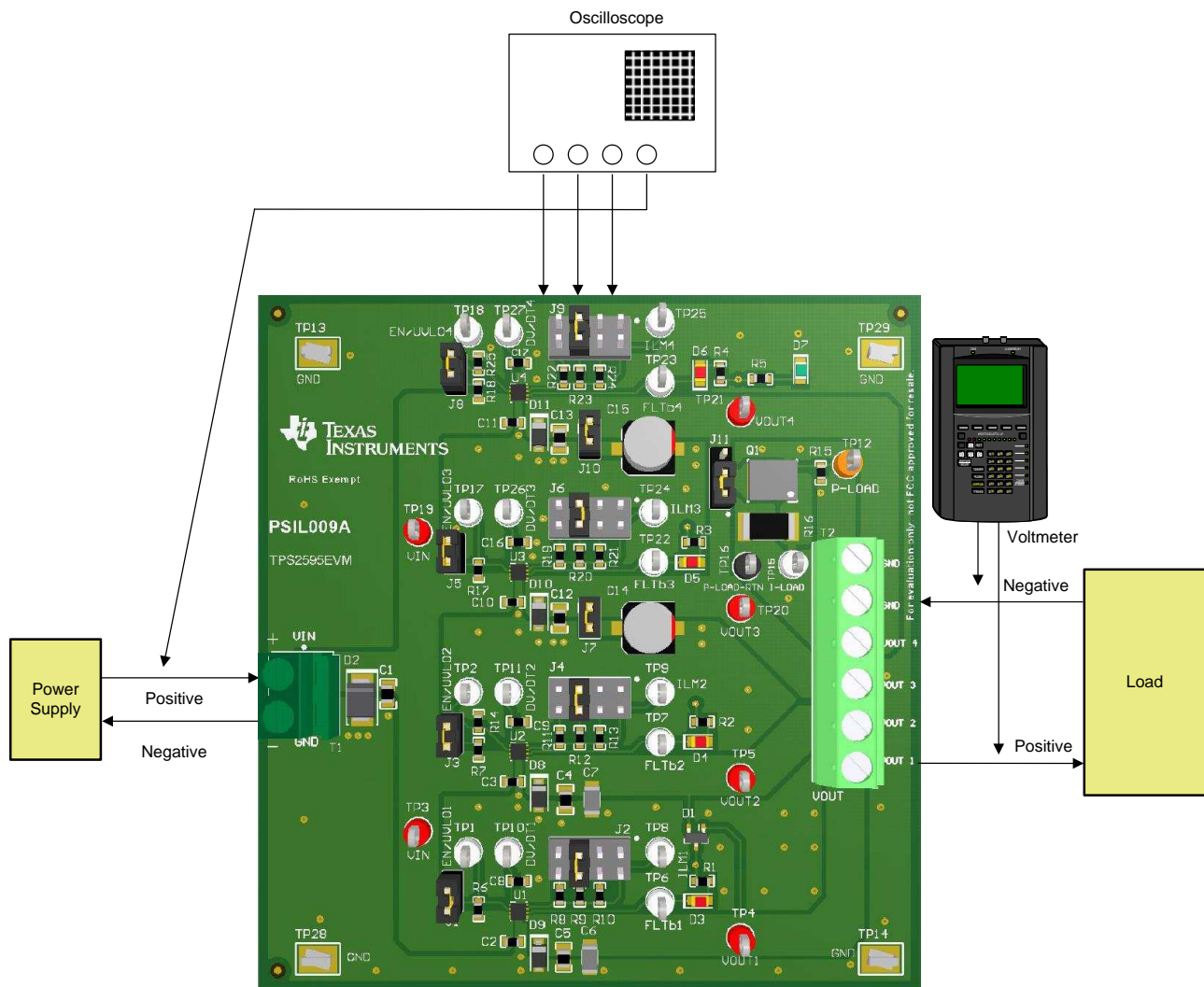

Copyright © 2017, Texas Instruments Incorporated

Figure 2. TPS2595EVM Setup With Test Equipment

Use the following instructions before starting any test and repeat again before moving to the next test:

- Set the power supply output (V_{IN}) to zero volts
- Turn ON the power supply and set the power supply output $V_{IN} = 12\text{ V}$, current limit = 5 A
- Turn OFF the power supply
- Set the jumper setting on EVM to the default position as shown in [Table 5](#)

5.1 Inrush Current Test

Use the following instructions to measure the inrush current for CH3:

1. Set the input supply voltage (V_{IN}) to 12 V at terminal T1 and enable the power supply
2. Apply a square wave (10-Hz frequency with 50% duty cycle) to the EN/UVLO pin at TP17 using a function generator
3. Observe the waveform at VOUT3 (TP20) with an oscilloscope to measure the slew rate and rise time of the eFuse with a given input voltage of 12 V

Figure 3 shows an example of inrush current captured on the TPS2595EVM eFuse evaluation board.

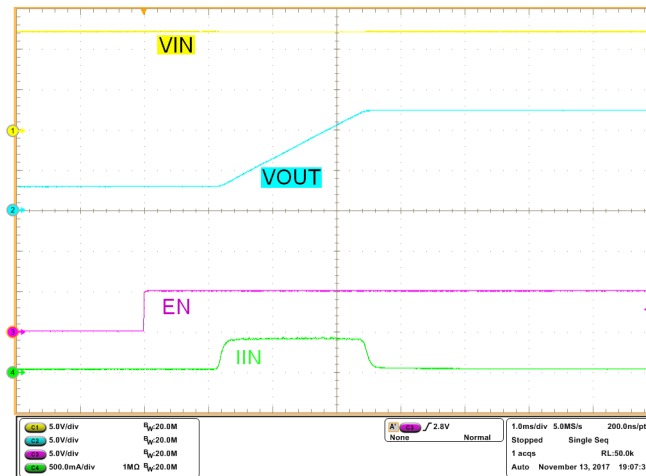

Figure 3. TPS259541 Output Rise Profile ($V_{IN} = 12\text{ V}$, $C_dVdT = 10\text{ nF}$, $C_{OUT} = 100\text{ }\mu\text{F}$, No-Load)

5.2 Current-Limit Test

Use the following instructions to perform a current-limit test for CH3:

1. Set the input supply voltage (V_{IN}) to 12 V at terminal T1 and enable the power supply
2. By default, the EVM is configured for a 2-A current limit
3. Set the load resistance to $14\text{ }\Omega$ and connect at terminal T2 between VOUT3 and GND
4. Increase the load by decreasing the load resistance to $4\text{ }\Omega$ to check the current-limit function
5. Place jumper J6 at other settings to test at various current limits

Figure 4 shows an example of current limit at 2 A for CH3 on the TPS2595EVM eFuse evaluation board.

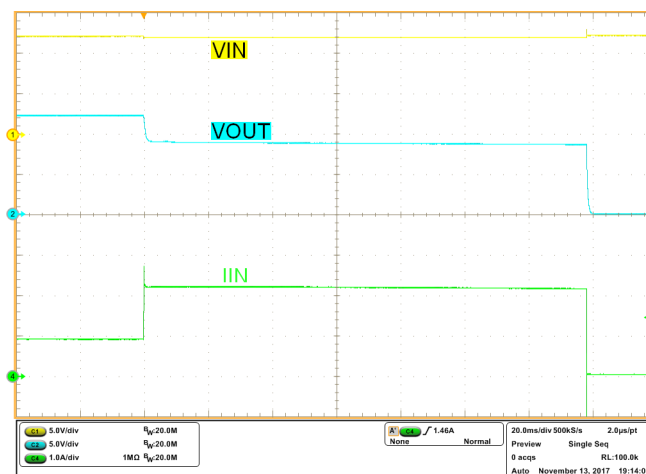

Figure 4. TPS259541 Overcurrent Response for 2-A Current-Limit Setting ($14\text{ }\Omega$ to $4\text{ }\Omega$)

5.3 Wakeup at Output Short Test

Use the following instructions to perform wakeup at short test for CH3:

1. Set the input supply voltage (V_{IN}) to 12 V at terminal T1 and turn OFF the power supply
2. By default, the EVM is configured for 2-A current limit
3. Short the output of CH3, that is, VOUT3 to GND with a shorter cable
4. Turn ON the power supply

Figure 5 shows test waveform of wakeup at output short for CH3 on the TPS2595EVM eFuse evaluation board.

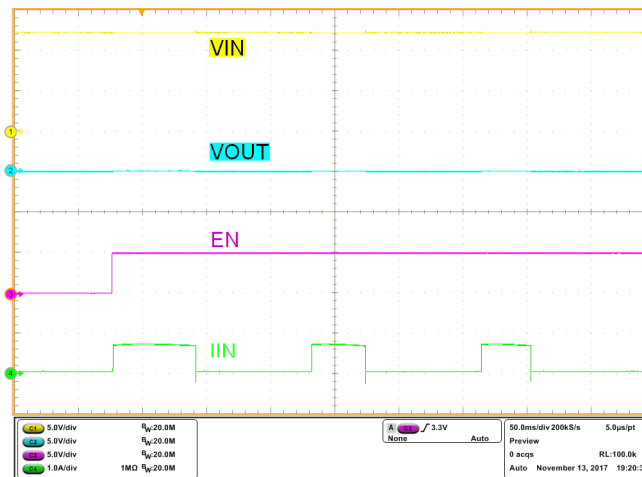

Figure 5. Test Waveform of Wakeup at Output Short for TPS259541 Device

5.4 Overvoltage Clamp Test

Use the following instructions to perform the overvoltage test for CH3:

1. Set the input supply voltage (V_{IN}) to 12 V at terminal T1 and enable the power supply
2. Set the load resistance to 500 Ω and connect at terminal T2 between VOUT3 and GND
3. Increase the input supply (V_{IN}) from 12 V to 16 V and observe the waveforms using an oscilloscope

Figure 6 shows overvoltage response of the TPS259541 on the TPS2595EVM eFuse evaluation board.

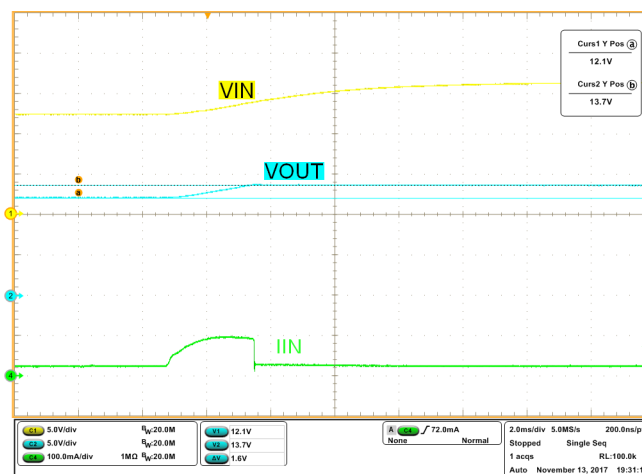

Figure 6. TPS259541 Overvoltage Clamp Response When V_{IN} is Increased From 12 V to 16 V

6 Evaluation Board Assembly Drawings and Layout Guidelines

6.1 PCB Drawings

Figure 7 shows component placement of the evaluation board. Figure 8 and Figure 9 show PCB layout images.

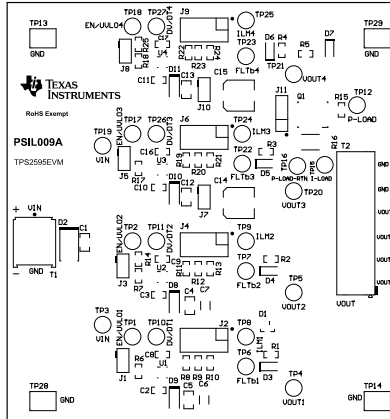

Figure 7. TPS2595EVM Board Top Assembly

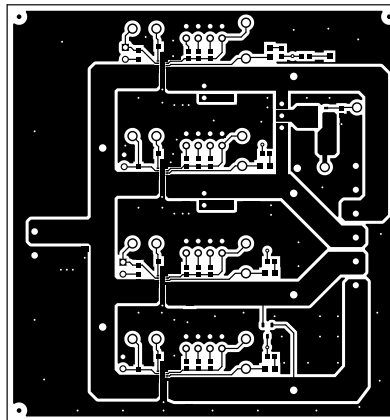

Figure 8. Top Layer

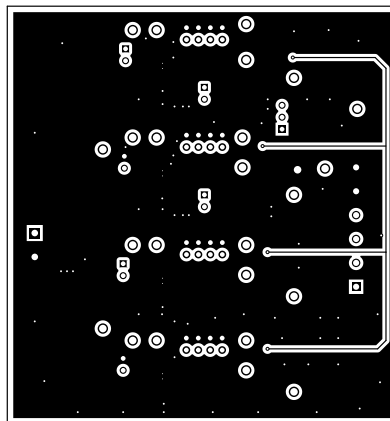

Figure 9. Bottom Layer

7 Bill Of Materials (BOM)

Table 6 lists the EVM BOM.

Table 6. TPS2595EVM Bill Of Materials⁽¹⁾

Designator	Qty	Value	Description	Package Reference	Part Number	Manufacturer	Alternate Part Number	Alternate Manufacturer
IPCB1	1		Printed Circuit Board		PSIL009	Any		
C1, C4, C5, C12, C13	5	1uF	CAP, CERM, 1 uF, 25 V, ±10%, X5R, 0805	0805	08053D105KAT2A	AVX		
C2, C3, C10, C11	4	0.1uF	CAP, CERM, 0.1 uF, 25 V, ±10%, X5R, 0603	0603	06033D104KAT2A	AVX		
C6, C7	2	22uF	CAP, CERM, 22 uF, 25 V, ±10%, X5R, 1206	1206	GRM31CR61E226KE15L	Murata		
C8, C9, C16, C17	4	0.01uF	CAP, CERM, 0.01 uF, 25 V, ±10%, X7R, 0603	0603	GRM188R71E103KA01D	Murata		
C14, C15	2	100uF	CAP, AL, 100 uF, 25 V, ±20%, SMD	D6.3xL7.7mm	865080445010	Würth Elektronik		
D1	1	30V	Diode, Schottky, 30 V, 0.2 A, SOT-23	SOT-23	BAT54C-7-F	Diodes Inc.		
D2	1	16V	Diode, TVS, Uni, 16 V, 26 Vc, SMB	SMB	SMBJ16A-13-F	Diodes Inc.		
D3, D4, D5, D6	4	Red	LED, Red, SMD	Red 0805 LED	LTST-C170KRKT	Lite-On		
D7	1	Green	LED, Green, SMD	LED_0805	LTST-C170KGKT	Lite-On		
D8, D9, D10, D11	4	30V	Diode, Schottky, 30 V, 1 A, SOD-123	SOD-123	MBR130T1G	ON Semiconductor		
H1, H2, H3, H4	4		Bumpon, Hemisphere, 0.44 X 0.20, Clear	Transparent Bumpon	SJ-5303 (CLEAR)	3M		
J1, J3, J5, J7, J8, J10	6		Header, 100mil, 2x1, Tin, TH	Header, 2 PIN, 100mil, Tin	PEC02SAAN	Sullins Connector Solutions		
J2, J4, J6, J9	4		Header, 100mil, 4x2, Tin, TH	Header, 4x2, 100mil, Tin	PEC04DAAN	Sullins Connector Solutions		
J11	1		Header, 100mil, 3x1, Tin, TH	Header, 3 PIN, 100mil, Tin	PEC03SAAN	Sullins Connector Solutions		
Q1	1	25V	MOSFET, N-CH, 25 V, 100 A, DNK0008A (VSON-CLIP-8)	DNK0008A	CSD16570Q5B	Texas Instruments		None
R1, R2, R3, R4, R5	5	3.24k	RES, 3.24 k, 1%, 0.1 W, 0603	0603	CRCW06033K24FKEA	Vishay-Dale		
R6, R7, R17, R18	4	1.00Meg	RES, 1.00 M, 1%, 0.1 W, 0603	0603	CRCW06031M00FKEA	Vishay-Dale		
R8, R11, R19, R22	4	487	RES, 487, 1%, 0.1 W, 0603	0603	CRCW0603487RFKEA	Vishay-Dale		
R9, R12, R20, R23	4	1.02k	RES, 1.02 k, 1%, 0.1 W, 0603	0603	CRCW06031K02FKEA	Vishay-Dale		
R10, R13, R21, R24	4	4.42k	RES, 4.42 k, 1%, 0.1 W, 0603	0603	CRCW06034K42FKEA	Vishay-Dale		
R14	1	374k	RES, 374 k, 1%, 0.1 W, 0603	0603	CRCW0603374KFKEA	Vishay-Dale		
R15	1	10.0k	RES, 10.0 k, 1%, 0.1 W, 0603	0603	CRCW060310K0FKEA	Vishay-Dale		
R16	1	0.1	RES, 0.1, 1%, 3 W, 2512	2512	CRA2512-FZ-R100ELF	Bourns		
R25	1	86.6k	RES, 86.6 k, 1%, 0.1 W, 0603	0603	CRCW060386K6FKEA	Vishay-Dale		
SH-J1, SH-J2, SH-J3, SH-J4, SH-J5, SH-J6, SH-J7, SH-J8, SH-J9, SH-J10, SH-J11	11	1x2	Shunt, 100mil, Gold plated, Black	Shunt	SNT-100-BK-G	Samtec	969102-0000-DA	3M
T1	1		Terminal Block, 2x1, 5.08mm, TH	10.16x15.2x9mm	282841-2	TE Connectivity		
T2	1		Terminal Block, 6x1, 5.08mm, Th	Terminal Block, 6x1, 5.08mm, TH	1729160	Phoenix Contact		

⁽¹⁾ Unless otherwise noted in the *Alternate Part Number* or *Alternate Manufacturer* columns, all parts may be substituted with equivalents.

Table 6. TPS2595EVM Bill Of Materials⁽¹⁾ (continued)

Designator	Qty	Value	Description	Package Reference	Part Number	Manufacturer	Alternate Part Number	Alternate Manufacturer
TP1, TP2, TP6, TP7, TP8, TP9, TP10, TP11, TP15, TP17, TP18, TP22, TP23, TP24, TP25, TP26, TP27	17		Test Point, Multipurpose, White, TH	White Multipurpose Testpoint	5012	Keystone		
TP3, TP4, TP5, TP19, TP20, TP21	6		Test Point, Multipurpose, Red, TH	Red Multipurpose Testpoint	5010	Keystone		
TP12	1		Test Point, Multipurpose, Orange, TH	Orange Multipurpose Testpoint	5013	Keystone		
TP13, TP14, TP28, TP29	4		Test Point, Compact, SMT	Testpoint_Keystone_C ompact	5016	Keystone		
TP16	1		Test Point, Multipurpose, Black, TH	Black Multipurpose Testpoint	5011	Keystone		
U1	1		12V eFuse with Over Voltage Protection, DSG0008A (WSN-8)	DSG0008A	TPS259520DSGR	Texas Instruments	TPS259520DSGT	Texas Instruments
U2	1		12V eFuse with Over Voltage Protection, DSG0008A (WSN-8)	DSG0008A	TPS259533DSGR	Texas Instruments	TPS259533DSGT	Texas Instruments
U3	1		12V eFuse with Over Voltage Protection, DSG0008A (WSN-8)	DSG0008A	TPS259541DSGR	Texas Instruments	TPS259541DSGT	Texas Instruments
U4	1		12V eFuse with Over Voltage Protection, DSG0008A (WSN-8)	DSG0008A	TPS259573DSGR	Texas Instruments	TPS259573DSGT	Texas Instruments
FID1, FID2, FID3	0		Fiducial mark. There is nothing to buy or mount.	N/A	N/A	N/A		

STANDARD TERMS FOR EVALUATION MODULES

1. *Delivery:* TI delivers TI evaluation boards, kits, or modules, including any accompanying demonstration software, components, and/or documentation which may be provided together or separately (collectively, an "EVM" or "EVMs") to the User ("User") in accordance with the terms set forth herein. User's acceptance of the EVM is expressly subject to the following terms.
 - 1.1 EVMs are intended solely for product or software developers for use in a research and development setting to facilitate feasibility evaluation, experimentation, or scientific analysis of TI semiconductor products. EVMs have no direct function and are not finished products. EVMs shall not be directly or indirectly assembled as a part or subassembly in any finished product. For clarification, any software or software tools provided with the EVM ("Software") shall not be subject to the terms and conditions set forth herein but rather shall be subject to the applicable terms that accompany such Software
 - 1.2 EVMs are not intended for consumer or household use. EVMs may not be sold, sublicensed, leased, rented, loaned, assigned, or otherwise distributed for commercial purposes by Users, in whole or in part, or used in any finished product or production system.
2. *Limited Warranty and Related Remedies/Disclaimers:*
 - 2.1 These terms do not apply to Software. The warranty, if any, for Software is covered in the applicable Software License Agreement.
 - 2.2 TI warrants that the TI EVM will conform to TI's published specifications for ninety (90) days after the date TI delivers such EVM to User. Notwithstanding the foregoing, TI shall not be liable for a nonconforming EVM if (a) the nonconformity was caused by neglect, misuse or mistreatment by an entity other than TI, including improper installation or testing, or for any EVMs that have been altered or modified in any way by an entity other than TI, (b) the nonconformity resulted from User's design, specifications or instructions for such EVMs or improper system design, or (c) User has not paid on time. Testing and other quality control techniques are used to the extent TI deems necessary. TI does not test all parameters of each EVM. User's claims against TI under this Section 2 are void if User fails to notify TI of any apparent defects in the EVMs within ten (10) business days after delivery, or of any hidden defects with ten (10) business days after the defect has been detected.
 - 2.3 TI's sole liability shall be at its option to repair or replace EVMs that fail to conform to the warranty set forth above, or credit User's account for such EVM. TI's liability under this warranty shall be limited to EVMs that are returned during the warranty period to the address designated by TI and that are determined by TI not to conform to such warranty. If TI elects to repair or replace such EVM, TI shall have a reasonable time to repair such EVM or provide replacements. Repaired EVMs shall be warranted for the remainder of the original warranty period. Replaced EVMs shall be warranted for a new full ninety (90) day warranty period.
3. *Regulatory Notices:*
 - 3.1 *United States*
 - 3.1.1 *Notice applicable to EVMs not FCC-Approved:*

FCC NOTICE: This kit is designed to allow product developers to evaluate electronic components, circuitry, or software associated with the kit to determine whether to incorporate such items in a finished product and software developers to write software applications for use with the end product. This kit is not a finished product and when assembled may not be resold or otherwise marketed unless all required FCC equipment authorizations are first obtained. Operation is subject to the condition that this product not cause harmful interference to licensed radio stations and that this product accept harmful interference. Unless the assembled kit is designed to operate under part 15, part 18 or part 95 of this chapter, the operator of the kit must operate under the authority of an FCC license holder or must secure an experimental authorization under part 5 of this chapter.
 - 3.1.2 *For EVMs annotated as FCC – FEDERAL COMMUNICATIONS COMMISSION Part 15 Compliant:*

CAUTION

This device complies with part 15 of the FCC Rules. Operation is subject to the following two conditions: (1) This device may not cause harmful interference, and (2) this device must accept any interference received, including interference that may cause undesired operation.

Changes or modifications not expressly approved by the party responsible for compliance could void the user's authority to operate the equipment.

FCC Interference Statement for Class A EVM devices

NOTE: This equipment has been tested and found to comply with the limits for a Class A digital device, pursuant to part 15 of the FCC Rules. These limits are designed to provide reasonable protection against harmful interference when the equipment is operated in a commercial environment. This equipment generates, uses, and can radiate radio frequency energy and, if not installed and used in accordance with the instruction manual, may cause harmful interference to radio communications. Operation of this equipment in a residential area is likely to cause harmful interference in which case the user will be required to correct the interference at his own expense.

FCC Interference Statement for Class B EVM devices

NOTE: This equipment has been tested and found to comply with the limits for a Class B digital device, pursuant to part 15 of the FCC Rules. These limits are designed to provide reasonable protection against harmful interference in a residential installation. This equipment generates, uses and can radiate radio frequency energy and, if not installed and used in accordance with the instructions, may cause harmful interference to radio communications. However, there is no guarantee that interference will not occur in a particular installation. If this equipment does cause harmful interference to radio or television reception, which can be determined by turning the equipment off and on, the user is encouraged to try to correct the interference by one or more of the following measures:

- Reorient or relocate the receiving antenna.
- Increase the separation between the equipment and receiver.
- Connect the equipment into an outlet on a circuit different from that to which the receiver is connected.
- Consult the dealer or an experienced radio/TV technician for help.

3.2 Canada

3.2.1 For EVMs issued with an Industry Canada Certificate of Conformance to RSS-210 or RSS-247

Concerning EVMs Including Radio Transmitters:

This device complies with Industry Canada license-exempt RSSs. Operation is subject to the following two conditions:

(1) this device may not cause interference, and (2) this device must accept any interference, including interference that may cause undesired operation of the device.

Concernant les EVMs avec appareils radio:

Le présent appareil est conforme aux CNR d'Industrie Canada applicables aux appareils radio exempts de licence. L'exploitation est autorisée aux deux conditions suivantes: (1) l'appareil ne doit pas produire de brouillage, et (2) l'utilisateur de l'appareil doit accepter tout brouillage radioélectrique subi, même si le brouillage est susceptible d'en compromettre le fonctionnement.

Concerning EVMs Including Detachable Antennas:

Under Industry Canada regulations, this radio transmitter may only operate using an antenna of a type and maximum (or lesser) gain approved for the transmitter by Industry Canada. To reduce potential radio interference to other users, the antenna type and its gain should be so chosen that the equivalent isotropically radiated power (e.i.r.p.) is not more than that necessary for successful communication. This radio transmitter has been approved by Industry Canada to operate with the antenna types listed in the user guide with the maximum permissible gain and required antenna impedance for each antenna type indicated. Antenna types not included in this list, having a gain greater than the maximum gain indicated for that type, are strictly prohibited for use with this device.

Concernant les EVMs avec antennes détachables

Conformément à la réglementation d'Industrie Canada, le présent émetteur radio peut fonctionner avec une antenne d'un type et d'un gain maximal (ou inférieur) approuvé pour l'émetteur par Industrie Canada. Dans le but de réduire les risques de brouillage radioélectrique à l'intention des autres utilisateurs, il faut choisir le type d'antenne et son gain de sorte que la puissance isotrope rayonnée équivalente (p.i.r.e.) ne dépasse pas l'intensité nécessaire à l'établissement d'une communication satisfaisante. Le présent émetteur radio a été approuvé par Industrie Canada pour fonctionner avec les types d'antenne énumérés dans le manuel d'usage et ayant un gain admissible maximal et l'impédance requise pour chaque type d'antenne. Les types d'antenne non inclus dans cette liste, ou dont le gain est supérieur au gain maximal indiqué, sont strictement interdits pour l'exploitation de l'émetteur.

3.3 Japan

3.3.1 *Notice for EVMs delivered in Japan:* Please see http://www.tij.co.jp/lstds/ti_ja/general/eStore/notice_01.page 日本国内に輸入される評価用キット、ボードについては、次のところをご覧ください。
http://www.tij.co.jp/lstds/ti_ja/general/eStore/notice_01.page

3.3.2 *Notice for Users of EVMs Considered "Radio Frequency Products" in Japan:* EVMs entering Japan may not be certified by TI as conforming to Technical Regulations of Radio Law of Japan.

If User uses EVMs in Japan, not certified to Technical Regulations of Radio Law of Japan, User is required to follow the instructions set forth by Radio Law of Japan, which includes, but is not limited to, the instructions below with respect to EVMs (which for the avoidance of doubt are stated strictly for convenience and should be verified by User):

1. Use EVMs in a shielded room or any other test facility as defined in the notification #173 issued by Ministry of Internal Affairs and Communications on March 28, 2006, based on Sub-section 1.1 of Article 6 of the Ministry's Rule for Enforcement of Radio Law of Japan,
2. Use EVMs only after User obtains the license of Test Radio Station as provided in Radio Law of Japan with respect to EVMs, or
3. Use of EVMs only after User obtains the Technical Regulations Conformity Certification as provided in Radio Law of Japan with respect to EVMs. Also, do not transfer EVMs, unless User gives the same notice above to the transferee. Please note that if User does not follow the instructions above, User will be subject to penalties of Radio Law of Japan.

【無線電波を送信する製品の開発キットをお使いになる際の注意事項】 開発キットの中には技術基準適合証明を受けていないものがあります。技術適合証明を受けていないものご使用に際しては、電波法遵守のため、以下のいずれかの措置を取っていただく必要がありますのでご注意ください。

1. 電波法施行規則第6条第1項第1号に基づく平成18年3月28日総務省告示第173号で定められた電波暗室等の試験設備でご使用いただく。
2. 実験局の免許を取得後ご使用いただく。
3. 技術基準適合証明を取得後ご使用いただく。

なお、本製品は、上記の「ご使用にあたっての注意」を譲渡先、移転先に通知しない限り、譲渡、移転できないものとします。

上記を遵守頂けない場合は、電波法の罰則が適用される可能性があることをご留意ください。日本テキサス・インスツルメンツ株式会社
東京都新宿区西新宿 6 丁目 2 4 番 1 号
西新宿三井ビル

3.3.3 *Notice for EVMs for Power Line Communication:* Please see http://www.tij.co.jp/lstds/ti_ja/general/eStore/notice_02.page
電力線搬送波通信についての開発キットをお使いになる際の注意事項については、次のところをご覧ください。 http://www.tij.co.jp/lstds/ti_ja/general/eStore/notice_02.page

3.4 *European Union*

3.4.1 *For EVMs subject to EU Directive 2014/30/EU (Electromagnetic Compatibility Directive):*

This is a class A product intended for use in environments other than domestic environments that are connected to a low-voltage power-supply network that supplies buildings used for domestic purposes. In a domestic environment this product may cause radio interference in which case the user may be required to take adequate measures.

4 *EVM Use Restrictions and Warnings:*

4.1 EVMS ARE NOT FOR USE IN FUNCTIONAL SAFETY AND/OR SAFETY CRITICAL EVALUATIONS, INCLUDING BUT NOT LIMITED TO EVALUATIONS OF LIFE SUPPORT APPLICATIONS.

4.2 User must read and apply the user guide and other available documentation provided by TI regarding the EVM prior to handling or using the EVM, including without limitation any warning or restriction notices. The notices contain important safety information related to, for example, temperatures and voltages.

4.3 *Safety-Related Warnings and Restrictions:*

4.3.1 User shall operate the EVM within TI's recommended specifications and environmental considerations stated in the user guide, other available documentation provided by TI, and any other applicable requirements and employ reasonable and customary safeguards. Exceeding the specified performance ratings and specifications (including but not limited to input and output voltage, current, power, and environmental ranges) for the EVM may cause personal injury or death, or property damage. If there are questions concerning performance ratings and specifications, User should contact a TI field representative prior to connecting interface electronics including input power and intended loads. Any loads applied outside of the specified output range may also result in unintended and/or inaccurate operation and/or possible permanent damage to the EVM and/or interface electronics. Please consult the EVM user guide prior to connecting any load to the EVM output. If there is uncertainty as to the load specification, please contact a TI field representative. During normal operation, even with the inputs and outputs kept within the specified allowable ranges, some circuit components may have elevated case temperatures. These components include but are not limited to linear regulators, switching transistors, pass transistors, current sense resistors, and heat sinks, which can be identified using the information in the associated documentation. When working with the EVM, please be aware that the EVM may become very warm.

4.3.2 EVMs are intended solely for use by technically qualified, professional electronics experts who are familiar with the dangers and application risks associated with handling electrical mechanical components, systems, and subsystems. User assumes all responsibility and liability for proper and safe handling and use of the EVM by User or its employees, affiliates, contractors or designees. User assumes all responsibility and liability to ensure that any interfaces (electronic and/or mechanical) between the EVM and any human body are designed with suitable isolation and means to safely limit accessible leakage currents to minimize the risk of electrical shock hazard. User assumes all responsibility and liability for any improper or unsafe handling or use of the EVM by User or its employees, affiliates, contractors or designees.

4.4 User assumes all responsibility and liability to determine whether the EVM is subject to any applicable international, federal, state, or local laws and regulations related to User's handling and use of the EVM and, if applicable, User assumes all responsibility and liability for compliance in all respects with such laws and regulations. User assumes all responsibility and liability for proper disposal and recycling of the EVM consistent with all applicable international, federal, state, and local requirements.

5. *Accuracy of Information:* To the extent TI provides information on the availability and function of EVMs, TI attempts to be as accurate as possible. However, TI does not warrant the accuracy of EVM descriptions, EVM availability or other information on its websites as accurate, complete, reliable, current, or error-free.

6. *Disclaimers:*

6.1 EXCEPT AS SET FORTH ABOVE, EVMS AND ANY MATERIALS PROVIDED WITH THE EVM (INCLUDING, BUT NOT LIMITED TO, REFERENCE DESIGNS AND THE DESIGN OF THE EVM ITSELF) ARE PROVIDED "AS IS" AND "WITH ALL FAULTS." TI DISCLAIMS ALL OTHER WARRANTIES, EXPRESS OR IMPLIED, REGARDING SUCH ITEMS, INCLUDING BUT NOT LIMITED TO ANY EPIDEMIC FAILURE WARRANTY OR IMPLIED WARRANTIES OF MERCHANTABILITY OR FITNESS FOR A PARTICULAR PURPOSE OR NON-INFRINGEMENT OF ANY THIRD PARTY PATENTS, COPYRIGHTS, TRADE SECRETS OR OTHER INTELLECTUAL PROPERTY RIGHTS.

6.2 EXCEPT FOR THE LIMITED RIGHT TO USE THE EVM SET FORTH HEREIN, NOTHING IN THESE TERMS SHALL BE CONSTRUED AS GRANTING OR CONFERRING ANY RIGHTS BY LICENSE, PATENT, OR ANY OTHER INDUSTRIAL OR INTELLECTUAL PROPERTY RIGHT OF TI, ITS SUPPLIERS/LICENSORS OR ANY OTHER THIRD PARTY, TO USE THE EVM IN ANY FINISHED END-USER OR READY-TO-USE FINAL PRODUCT, OR FOR ANY INVENTION, DISCOVERY OR IMPROVEMENT, REGARDLESS OF WHEN MADE, CONCEIVED OR ACQUIRED.

7. *USER'S INDEMNITY OBLIGATIONS AND REPRESENTATIONS.* USER WILL DEFEND, INDEMNIFY AND HOLD TI, ITS LICENSORS AND THEIR REPRESENTATIVES HARMLESS FROM AND AGAINST ANY AND ALL CLAIMS, DAMAGES, LOSSES, EXPENSES, COSTS AND LIABILITIES (COLLECTIVELY, "CLAIMS") ARISING OUT OF OR IN CONNECTION WITH ANY HANDLING OR USE OF THE EVM THAT IS NOT IN ACCORDANCE WITH THESE TERMS. THIS OBLIGATION SHALL APPLY WHETHER CLAIMS ARISE UNDER STATUTE, REGULATION, OR THE LAW OF TORT, CONTRACT OR ANY OTHER LEGAL THEORY, AND EVEN IF THE EVM FAILS TO PERFORM AS DESCRIBED OR EXPECTED.

8. *Limitations on Damages and Liability:*

8.1 *General Limitations.* IN NO EVENT SHALL TI BE LIABLE FOR ANY SPECIAL, COLLATERAL, INDIRECT, PUNITIVE, INCIDENTAL, CONSEQUENTIAL, OR EXEMPLARY DAMAGES IN CONNECTION WITH OR ARISING OUT OF THESE TERMS OR THE USE OF THE EVMS , REGARDLESS OF WHETHER TI HAS BEEN ADVISED OF THE POSSIBILITY OF SUCH DAMAGES. EXCLUDED DAMAGES INCLUDE, BUT ARE NOT LIMITED TO, COST OF REMOVAL OR REINSTALLATION, ANCILLARY COSTS TO THE PROCUREMENT OF SUBSTITUTE GOODS OR SERVICES, RETESTING, OUTSIDE COMPUTER TIME, LABOR COSTS, LOSS OF GOODWILL, LOSS OF PROFITS, LOSS OF SAVINGS, LOSS OF USE, LOSS OF DATA, OR BUSINESS INTERRUPTION. NO CLAIM, SUIT OR ACTION SHALL BE BROUGHT AGAINST TI MORE THAN TWELVE (12) MONTHS AFTER THE EVENT THAT GAVE RISE TO THE CAUSE OF ACTION HAS OCCURRED.

8.2 *Specific Limitations.* IN NO EVENT SHALL TI'S AGGREGATE LIABILITY FROM ANY USE OF AN EVM PROVIDED HEREUNDER, INCLUDING FROM ANY WARRANTY, INDEMNITY OR OTHER OBLIGATION ARISING OUT OF OR IN CONNECTION WITH THESE TERMS, , EXCEED THE TOTAL AMOUNT PAID TO TI BY USER FOR THE PARTICULAR EVM(S) AT ISSUE DURING THE PRIOR TWELVE (12) MONTHS WITH RESPECT TO WHICH LOSSES OR DAMAGES ARE CLAIMED. THE EXISTENCE OF MORE THAN ONE CLAIM SHALL NOT ENLARGE OR EXTEND THIS LIMIT.

9. *Return Policy.* Except as otherwise provided, TI does not offer any refunds, returns, or exchanges. Furthermore, no return of EVM(s) will be accepted if the package has been opened and no return of the EVM(s) will be accepted if they are damaged or otherwise not in a resalable condition. If User feels it has been incorrectly charged for the EVM(s) it ordered or that delivery violates the applicable order, User should contact TI. All refunds will be made in full within thirty (30) working days from the return of the components(s), excluding any postage or packaging costs.

10. *Governing Law:* These terms and conditions shall be governed by and interpreted in accordance with the laws of the State of Texas, without reference to conflict-of-laws principles. User agrees that non-exclusive jurisdiction for any dispute arising out of or relating to these terms and conditions lies within courts located in the State of Texas and consents to venue in Dallas County, Texas. Notwithstanding the foregoing, any judgment may be enforced in any United States or foreign court, and TI may seek injunctive relief in any United States or foreign court.

IMPORTANT NOTICE FOR TI DESIGN INFORMATION AND RESOURCES

Texas Instruments Incorporated ("TI") technical, application or other design advice, services or information, including, but not limited to, reference designs and materials relating to evaluation modules, (collectively, "TI Resources") are intended to assist designers who are developing applications that incorporate TI products; by downloading, accessing or using any particular TI Resource in any way, you (individually or, if you are acting on behalf of a company, your company) agree to use it solely for this purpose and subject to the terms of this Notice.

TI's provision of TI Resources does not expand or otherwise alter TI's applicable published warranties or warranty disclaimers for TI products, and no additional obligations or liabilities arise from TI providing such TI Resources. TI reserves the right to make corrections, enhancements, improvements and other changes to its TI Resources.

You understand and agree that you remain responsible for using your independent analysis, evaluation and judgment in designing your applications and that you have full and exclusive responsibility to assure the safety of your applications and compliance of your applications (and of all TI products used in or for your applications) with all applicable regulations, laws and other applicable requirements. You represent that, with respect to your applications, you have all the necessary expertise to create and implement safeguards that (1) anticipate dangerous consequences of failures, (2) monitor failures and their consequences, and (3) lessen the likelihood of failures that might cause harm and take appropriate actions. You agree that prior to using or distributing any applications that include TI products, you will thoroughly test such applications and the functionality of such TI products as used in such applications. TI has not conducted any testing other than that specifically described in the published documentation for a particular TI Resource.

You are authorized to use, copy and modify any individual TI Resource only in connection with the development of applications that include the TI product(s) identified in such TI Resource. NO OTHER LICENSE, EXPRESS OR IMPLIED, BY ESTOPPEL OR OTHERWISE TO ANY OTHER TI INTELLECTUAL PROPERTY RIGHT, AND NO LICENSE TO ANY TECHNOLOGY OR INTELLECTUAL PROPERTY RIGHT OF TI OR ANY THIRD PARTY IS GRANTED HEREIN, including but not limited to any patent right, copyright, mask work right, or other intellectual property right relating to any combination, machine, or process in which TI products or services are used. Information regarding or referencing third-party products or services does not constitute a license to use such products or services, or a warranty or endorsement thereof. Use of TI Resources may require a license from a third party under the patents or other intellectual property of the third party, or a license from TI under the patents or other intellectual property of TI.

TI RESOURCES ARE PROVIDED "AS IS" AND WITH ALL FAULTS. TI DISCLAIMS ALL OTHER WARRANTIES OR REPRESENTATIONS, EXPRESS OR IMPLIED, REGARDING TI RESOURCES OR USE THEREOF, INCLUDING BUT NOT LIMITED TO ACCURACY OR COMPLETENESS, TITLE, ANY EPIDEMIC FAILURE WARRANTY AND ANY IMPLIED WARRANTIES OF MERCHANTABILITY, FITNESS FOR A PARTICULAR PURPOSE, AND NON-INFRINGEMENT OF ANY THIRD PARTY INTELLECTUAL PROPERTY RIGHTS.

TI SHALL NOT BE LIABLE FOR AND SHALL NOT DEFEND OR INDEMNIFY YOU AGAINST ANY CLAIM, INCLUDING BUT NOT LIMITED TO ANY INFRINGEMENT CLAIM THAT RELATES TO OR IS BASED ON ANY COMBINATION OF PRODUCTS EVEN IF DESCRIBED IN TI RESOURCES OR OTHERWISE. IN NO EVENT SHALL TI BE LIABLE FOR ANY ACTUAL, DIRECT, SPECIAL, COLLATERAL, INDIRECT, PUNITIVE, INCIDENTAL, CONSEQUENTIAL OR EXEMPLARY DAMAGES IN CONNECTION WITH OR ARISING OUT OF TI RESOURCES OR USE THEREOF, AND REGARDLESS OF WHETHER TI HAS BEEN ADVISED OF THE POSSIBILITY OF SUCH DAMAGES.

You agree to fully indemnify TI and its representatives against any damages, costs, losses, and/or liabilities arising out of your non-compliance with the terms and provisions of this Notice.

This Notice applies to TI Resources. Additional terms apply to the use and purchase of certain types of materials, TI products and services. These include; without limitation, TI's standard terms for semiconductor products (<http://www.ti.com/sc/docs/stdterms.htm>), [evaluation modules](#), and [samples](http://www.ti.com/sc/docs/sampterm.htm) (<http://www.ti.com/sc/docs/sampterm.htm>).

Mailing Address: Texas Instruments, Post Office Box 655303, Dallas, Texas 75265
Copyright © 2017, Texas Instruments Incorporated







Looking for pricing, stock, or lifecycle information?

Click below to explore more details on WIN SOURCE:

 [View TPS2595EVM](#) on WIN SOURCE

 [Texas Instruments](#) Information

Optimize Your Supply Chain with WIN SOURCE Solutions

-  Global Sourcing Solution
-  Obsolete Management
-  Cost Control Management
-  Shortage Management
-  Alternative Solution
-  Excess Inventory Management