



**THE DATASHEET OF
KTD2061EUAC-TR**



36-Channel RGB LED Drivers with I²C Control

Features

- Drives up to 36 LEDs (12 RGBs)
- Multiplexed LED Current Driver Outputs
 - ▶ Only 12 PCB Traces to the LEDs
 - ▶ 23kHz MUX Frequency Prevents Audio Noise
- 14 Million Colors
 - ▶ LED Current: 125µA to 24mA in 125µA Steps
 - ▶ Night-Mode: 8µA to 1.5mA in 8µA Steps
 - ▶ 5% Max. Current Accuracy & Matching
- 36 Independent Exponential Fade-Engines
 - ▶ Ultra-Smooth 3072-Step Fade Resolution
 - ▶ 3-bit Programmable Fade Rate
 - ▶ Dramatically Reduces Software Complexity
- Patented¹ BrightExtend™ Technology
 - ▶ Maintains Color-Accuracy and PSRR for Battery-Powered Applications with Low Vin
- Proprietary CoolExtend™ Technology
 - ▶ 2-bit Programmable Max. Die-Temp Regulation
- 0.4µA Automatic Shutdown (Standby) Current
- 1MHz I²C Interface with Multiple Slave Addresses
- 2.5V to 5.5V Operating Supply Voltage Range
- -40°C to 85°C Operating Temperature Range
- 20 pin UQFN 3x3mm (0.4mm pitch)
- RoHS and Green Compliant

Applications

- AI Smart Speakers, Bluetooth / WiFi Loudspeakers
- Automotive Panel, Accent and Mood Lighting
- IoT, Gaming PC/Keyboards/Controllers/VR, Robots

Brief Description

The KTD2061/58/59/60 are fully programmable current regulators for up to 12 RGB LED modules (36 LEDs total). The devices are ideally powered from a supply rail in the 3V to 5V nominal range. Three 4-wire buses are multiplexed to reduce the pin-count and PCB traces to the LEDs.

The I²C control interface is used to set the LED color palette and then dynamically select the on/off status and color of each RGB module. For applications requiring more RGBs on one I²C bus, the KTD2061/58/59/60 have different slave addresses.

36 independent fade-up/down engines are integrated for independent ramping of each LED's current during on/off, brightness, and color transitions without software burden. The exponential current ramps provide visually pleasing fades with eight I²C programmable fade-rate settings. 3072-step fade resolution ensures ultra-smooth visual effects.

BrightExtend™ optionally reduces dropout when the input voltage is too low for the forward voltage of the LEDs, enabling battery-powered applications. Programmable CoolExtend™ prevents excessive heat by regulating die temperature when the input voltage, current settings, and/or ambient temperature are high.

The KTD2061/58/59/60 are packaged in RoHS and Green compliant 3mm x 3mm UQFN packages with 0.58mm maximum height.

Typical Application

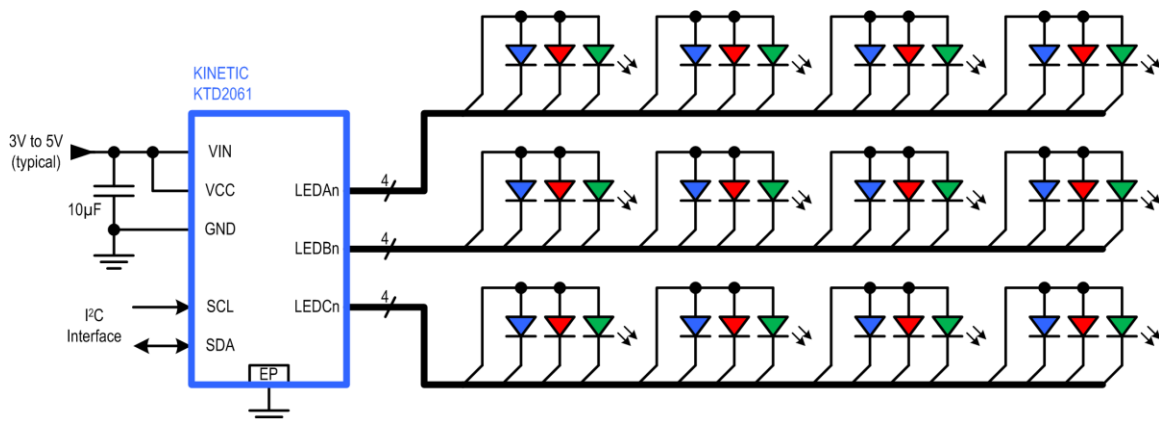

1. US Patent 8,482,216 B1

Pin Descriptions

Pin #	Name	Function
1, 2	VIN	Voltage Input to the LEDs – connect a 10µF capacitor from VIN to the PCB ground plane using multiple vias.
3	VCC	Voltage Supply Input for the IC – connect VCC to VIN and its 10µF capacitor.
4	SCL	I ² C Serial Interface Clock
5	SDA	I ² C Serial Interface Data
6	LEDA1	LED connection for bus A, wire 1.
7	LEDA2	LED connection for bus A, wire 2.
8, 13, 18	GND	Ground – connect to the PCB ground plane using multiple vias.
9	LEDA3	LED connection for bus A, wire 3.
10	LEDA4	LED connection for bus A, wire 4.
11	LEDB1	LED connection for bus B, wire 1.
12	LEDB2	LED connection for bus B, wire 2.
14	LEDB3	LED connection for bus B, wire 3.
15	LEDB4	LED connection for bus B, wire 4.
16	LEDC1	LED connection for bus C, wire 1.
17	LEDC2	LED connection for bus C, wire 2.
19	LEDC3	LED connection for bus C, wire 3.
20	LEDC4	LED connection for bus C, wire 4.
--	EP	Exposed Paddle -- connect to PCB ground plane using multiple vias directly under the IC.

UQFN33-20

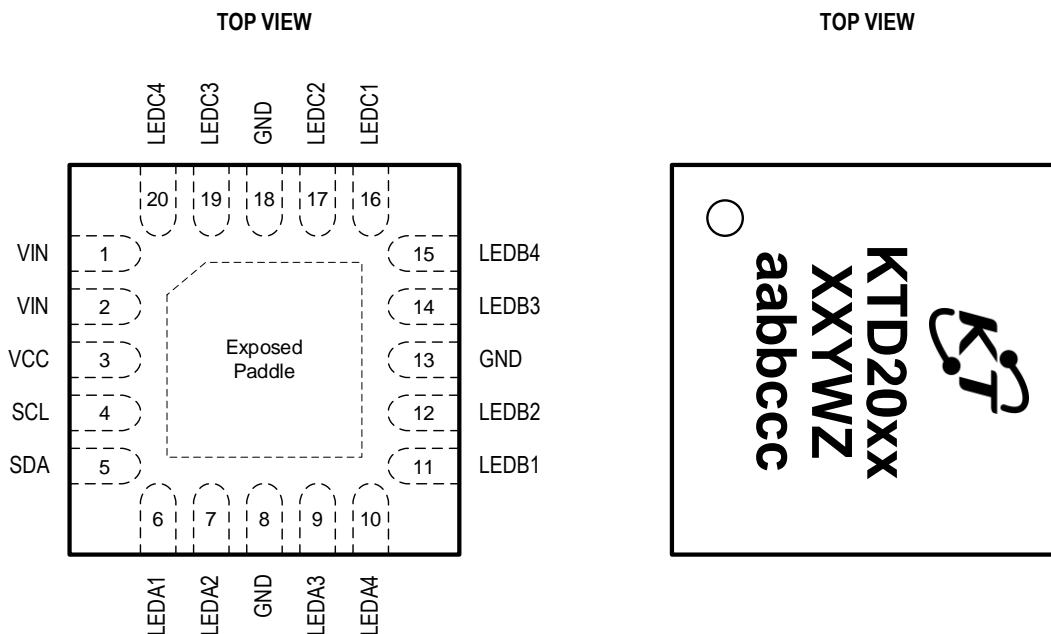

20-Pin 3mm x 3mm x 0.52mm
 UQFN Package, 0.4mm pitch
 Top Mark

XX = Device ID Code, YW = Fab Date Code, Z = Serial Number
 aabbccc = Assembly Date Code

Ordering Information

Part Number	Default I ² C Slave Address ²	Marking ³	Operating Temperature	Package
KTD2061EUAC-TR	0x68 Primary Option	NCYWZ aabbccc	-40°C to +85°C	UQFN33-20
KTD2058EUAC-TR	0x69 Secondary Option	OEYWZ aabbccc	-40°C to +85°C	UQFN33-20
KTD2059EUAC-TR	0x6A	OFYWZ aabbccc	-40°C to +85°C	UQFN33-20
KTD2060EUAC-TR	0x6B	OCYWZ aabbccc	-40°C to +85°C	UQFN33-20

Part Number	Description	Package
KTD2061EUAC-EV1	KTD2061 EVAL Kit	UQFN33-20

Absolute Maximum Ratings⁴

(T_A = 25°C unless otherwise noted)

Symbol	Description	Value	Units
V _{CC}	VCC to GND	-0.3 to 6	V
V _{IO}	SCL, SDA to GND	-0.3 to 6	V
V _{IN}	VIN to VCC	-0.3 to +0.3	V
V _{LED_n}	LEDA1, LEDA2, LEDA3, LEDA4, LEDB1, LEDB2, LEDB3, LEDB4, LEDC1, LEDC2, LEDC3, LEDC4 to GND	-0.3 to (V _{CC} +0.3)	V
T _J	Operating Temperature Range	-40 to 150	°C
T _S	Storage Temperature Range	-55 to 150	°C
T _{LEAD}	Maximum Soldering Temperature (at leads, 10 sec)	260	°C

ESD Ratings⁵

Symbol	Description	Value	Units
V _{ESD_HBM}	JEDEC JS-001-2017 ESD Human Body Model (all pins)	±2	kV

Thermal Capabilities⁶

Symbol	Description	Value	Units
Θ _{JA}	Thermal Resistance – Junction to Ambient	48	°C/W
P _D	Maximum Power Dissipation at T _A = 25°C (T _J = 150°C)	2.6	W
ΔP _D /ΔT	Derating Factor Above T _A = 25°C	-20.8	mW/°C

² Alternative I²C slave addresses are available should more than 36 channels be used in the same system. "Primary Option" and "Secondary Option" means the device is stocked for the majority of customers.

3. YW = Fab Date Code, Z = Serial Number, aabbccc = Assembly Date Code.

4. Stresses above those listed in Absolute Maximum Ratings may cause permanent damage to the device. Functional operation at conditions other than the operating conditions specified is not implied. Only one Absolute Maximum rating should be applied at any one time.

5. ESD Ratings conform to JEDEC industry standards. Some pins may actually have higher performance. Ratings apply with chip enabled, disabled, or unpowered, unless otherwise noted.

6. Junction to Ambient thermal resistance is highly dependent on PCB layout. Values are based on thermal properties of the device when soldered to an EV board.

Electrical Characteristics⁷

Unless otherwise noted, the *Min* and *Max* specs are applied over the full operation temperature range of -40°C to +85°C and $V_{CC} = V_{IN} = 2.5V$ to $5.5V$. Typical values are specified at $T_A = +25^\circ C$ with $V_{CC} = V_{IN} = 3.6V$.

Supply Specifications

Symbol	Description	Conditions	Min	Typ	Max	Units
V_{CC}	Supply Operating Range		2.5		5.5	V
V_{POR}	Power-On-Reset Threshold	V_{CC} Rising threshold		1.8		V
		Hysteresis		100		mV
V_{UVLO}	Under-Voltage Lockout Threshold	V_{CC} Rising threshold	2.2	2.3	2.4	V
		Hysteresis		100		mV
I_{CC}	No-Load Supply Current	Enabled via I ² C, all 0mA setting		1		mA
		Shutdown via I ² C, $V_{IH} = V_{CC} = V_{IN}$		0.4		μA

Thermal Shutdown Specifications

Symbol	Description	Conditions	Min	Typ	Max	Units
T_{J_SHDN}	IC Junction Thermal Shutdown	T_J rising		150		°C
		Hysteresis		20		°C

I²C-Compatible Interface Specifications (SCL, SDA), see Figure 1

Symbol	Description	Conditions	Min	Typ	Max	Units
V_{IH}	Input Logic High Voltage		1.2			V
V_{IL}	Input Logic Low Voltage				0.4	V
V_{OL}	SDA Output Logic Low Voltage	$I_{SDA} = 3mA$			0.4	V
t_1	SCL clock period		2.5			μs
t_2	Data in setup time to SCL high		100			ns
t_3	Data out stable after SCL low		0			ns
t_4	SDA low setup time to SCL low (Start)		100			ns
t_5	SDA high hold time after SCL high (Stop)		100			ns

(continued next page)

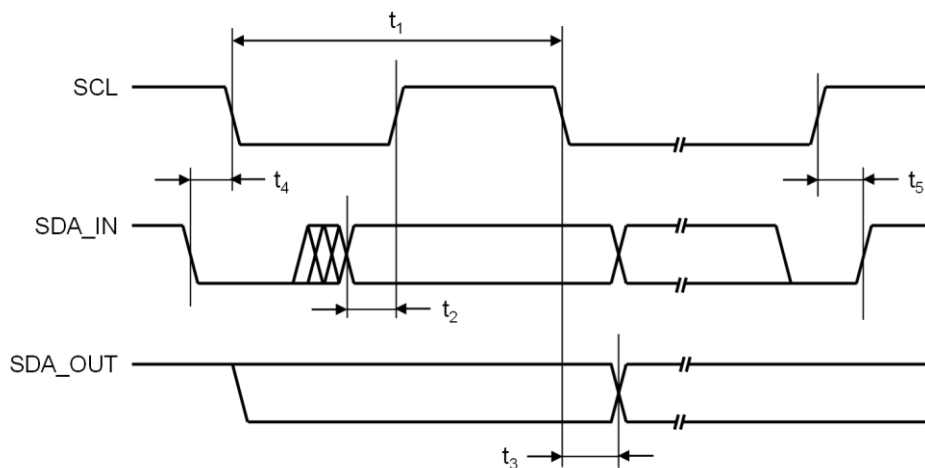

Figure 1. I²C Compatible Interface Timing

7. Device is guaranteed to meet performance specifications over the -40°C to +85°C operating temperature range by design, characterization and correlation with statistical process controls.

Electrical Characteristics (continued)⁷

Unless otherwise noted, the *Min* and *Max* specs are applied over the full operation temperature range of -40°C to +85°C and $V_{CC} = V_{IN} = 2.5V$ to $5.5V$. Typical values are specified at $T_A = +25^\circ C$ with $V_{CC} = V_{IN} = 3.6V$.

LED Driver Specifications (LED_n)

Symbol	Description	Conditions	Min	Typ	Max	Units
I _{LED_SET}	Current Setting Range	192 steps of 0.125mA/step	0		24	mA
I _{LED_NM}	Night-Mode Current Setting Range	192 steps of 7.8125µA/step	0		1.5	mA
I _{LED_ON}	Current Sink Range (during t _{SLOT})	4*I _{LED_SET} , 192 steps of 0.5mA/step	0		96	mA
I _{LED_ACC}	Current Sink Accuracy	I _{LED_ON} = 96mA setting, $V_{CC} = V_{IN} = 3.6V$	-5	±1	+5	%
I _{LED_MATCH}	Current Sink Matching	I _{LED_ON} = 96mA setting, $V_{CC} = V_{IN} = 3.6V$ $(I_{LED} - I_{AVG})/I_{AVG}$	-5	±1	+5	%
I _{LED_LIN}	Current Sink Linearity	Offset Error		±0.1		LSB
		Differential Non-Linearity (DNL)		±0.2		
		Integral Non-Linearity (INL)		±0.3		
V _{LED_DO}	Current Sink Dropout Voltage	I _{LED_ON} = 96mA, I _{LED_ON} reduced to 90% of what it is with 1V headroom.		210		mV
I _{LED_LK}	Current Sink Leakage	V _{LED_N} =V _{IN} , 0mA setting or shutdown		0.01	1	µA
R _{ON_SW}	LED_n Switch On-Resistance	Switch on		1.3		Ω
I _{LK_SW}	LED_n Switch Off Leakage	Switch off, LED_n=GND		0.01	1	µA

Multiplexor Timing Specifications

Symbol	Description	Conditions	Min	Typ	Max	Units
t _{FRAME}	Multiplexor Frame Time	Period	39	43.5	48	µs
		Frequency		23		kHz
t _{SLOT}	Multiplexor Slot Time	¼ of frame time		10.9		µs

Exponential Fade-Engine Specifications

Symbol	Description	Conditions	Min	Typ	Max	Units
I _{FADE_STEP}	Fade Resolution			7.8125		µA
t _{FADE_RATE}	Fade Time Constant Setting Range	Exponential time constant, 8 settings in octave increments	31		4000	ms

BrightExtend™ Technology Specifications

Symbol	Description	Conditions	Min	Typ	Max	Units
V _{DO_DETECT}	Current Sink Dropout Detection Voltage Threshold			V _{LED_DO}		mV
I _{LED_SCALE}	Global Current Scaling Range	BE_EN = 1	25		100	%

CoolExtend™ Technology Specifications

Symbol	Description	Conditions	Min	Typ	Max	Units
T _{J_REG}	Die Temperature Limiting Threshold Setting Range	4 steps of 15°C/step	90		135	°C
I _{LED_SCALE}	Global Current Scaling Range		25		100	%

Typical Characteristics

$V_{CC} = V_{IN} = 3.6V$, $T_A = +25^\circ C$, unless otherwise noted.

VCC Current vs. Supply Voltage

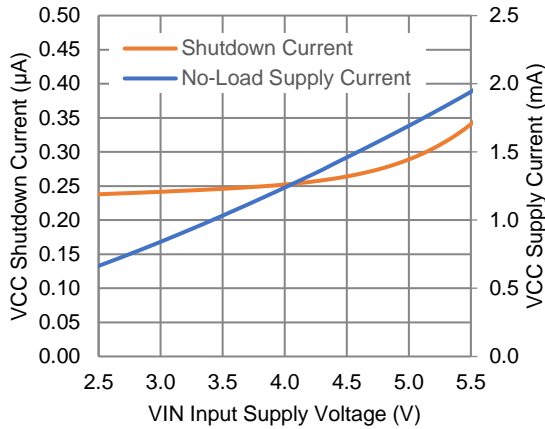

VCC Supply (No-Load) Current vs. Temperature

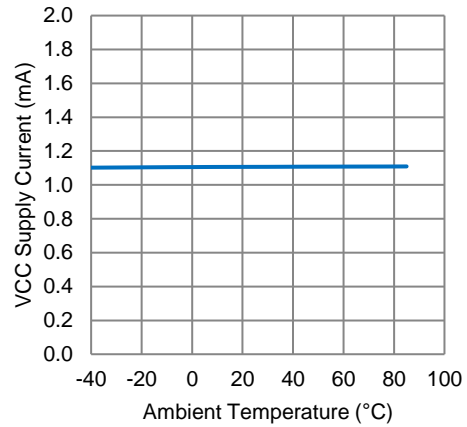

LED Current vs. Temperature (36 Channels in 20mA Setting)

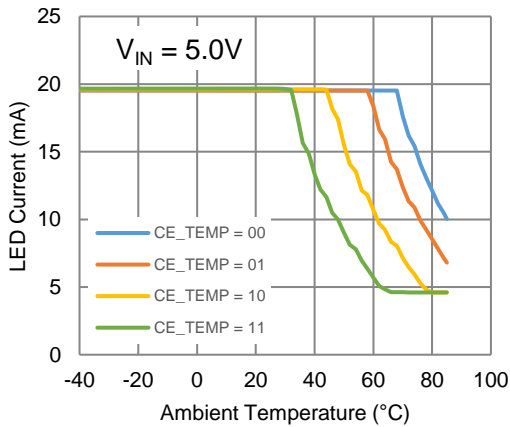

LED Current vs. Temperature (18 Channels in 15mA Setting)

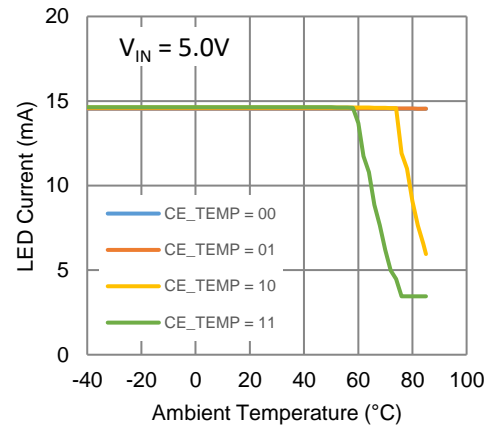

Non-Linearity vs. LED Current Setting (full-scale error corrected, offset error not corrected)

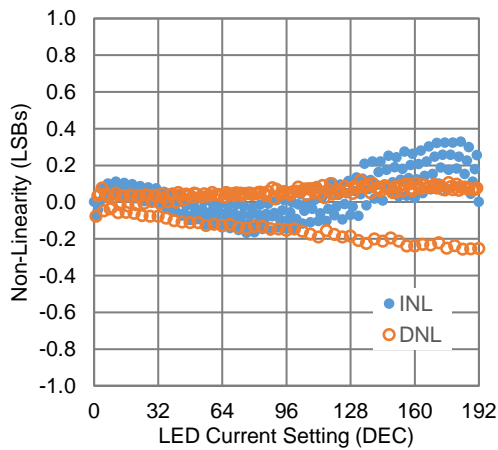

Typical Breathing Pattern Waveforms

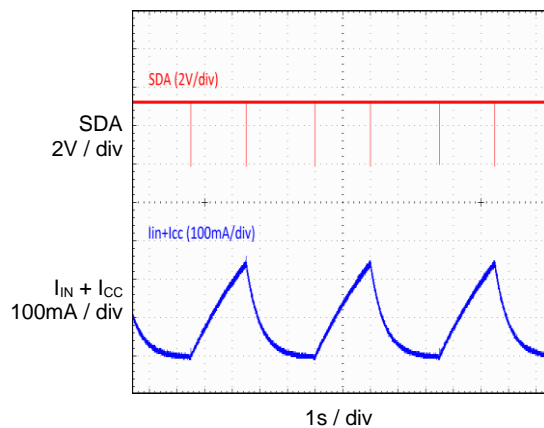

Functional Block Diagram

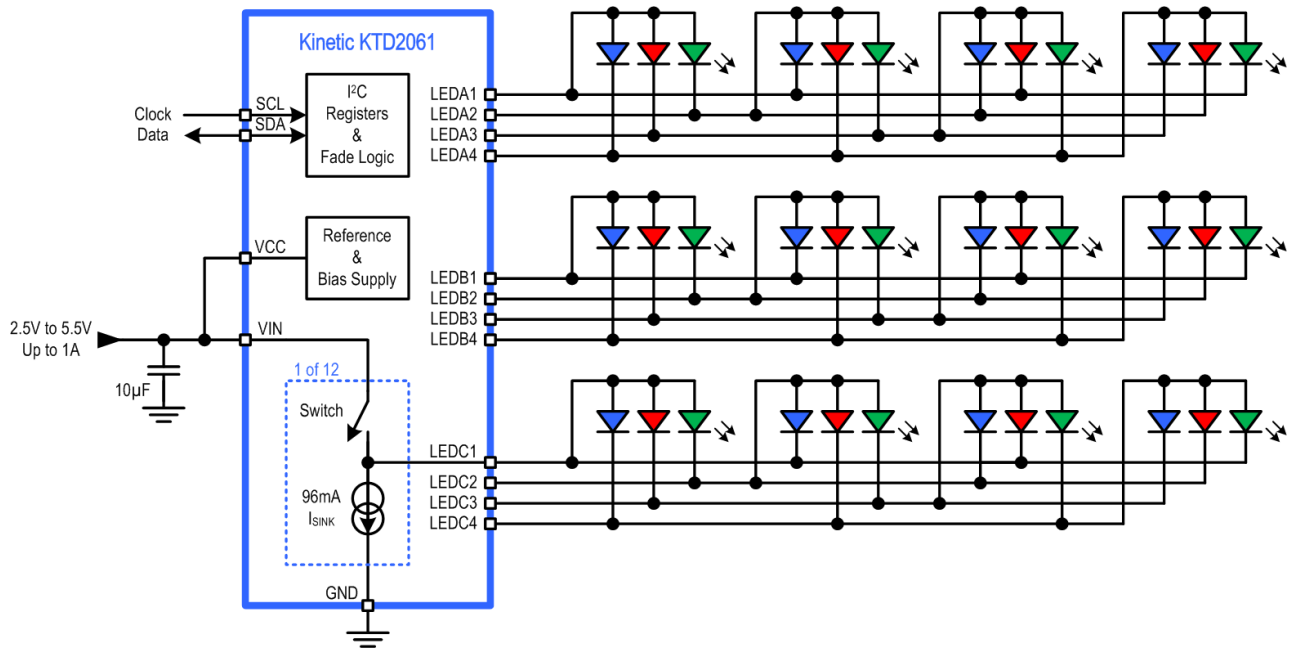

Figure 2. Functional Block Diagram

Functional Description

The KTD2061/58/59/60 are fully programmable current regulators for up to 12 RGB LED modules (36 LEDs total). They are highly optimized for applications that require color lighting effects and software-generated lighting patterns. Multiplexing is utilized to reduce the number of pins and number of PCB traces to the LEDs. A flexible but compact I²C register set and 36 integrated exponential fade-engines greatly simplify the system software for complex lighting patterns. The register set includes a chip ID register, a fault/status MONITOR register, a global CONTROL register, six Color Setting registers, and six Selection registers used to assign colors and on/off to each of the 12 RGB modules.

Multiplexing

Multiplexing enables 3x fewer wires/pins than conventional use of one wire per LED. The multiplexing uses three 4-wire busses such that each LED channel is enabled for 25% duty-cycle at 23kHz frequency. The frequency is chosen to be above the audio range. At this frequency and duty-cycle, most LEDs allow safe operation up to 100mA peak pulses. The KTD2061/58/59/60 use current pulses up to 96mA peak, resulting in nominal average LED current settings up to 24mA.

The ID Register

The read-only ID register contains the vendor ID for Kinetic Technologies and chip ID for KTD2061/58/59/60.

The MONITOR Register and Fault Protection

The read-only MONITOR register contains bits for the die revision, short-circuit status, BrightExtend™ dropout status, CoolExtend™ die temperature status, and under-voltage lockout status or over-temperature thermal shutdown status.

In addition to just monitoring status, the KTD2061/58/59/60 contain protection circuits to safely withstand various fault conditions including:

1. Output Short-Circuit to GND
2. Output Short-Circuit to VIN
3. LED Failure as a Short-Circuit
4. LED Failure as an Open-Circuit
5. BrightExtend™ to reduce LED Dropout due to V_{IN} too low to support LED V_f
6. CoolExtend™ to prevent warm or hot die temperature due to power dissipation
7. Under-Voltage Lockout due to V_{IN} too low to support IC functionality
8. Thermal Shutdown due to excessive ambient or die temperature

The CONTROL Register

The CONTROL register contains bits that select Normal Mode, Night Mode, Global Off Request and Shutdown Mode, Register Reset, BrightExtend™, CoolExtend™, and the Exponential Fade Rate.

Normal Mode

By default, the KTD2061/58/59/60 power up in Shutdown Mode when power is first applied at V_{CC} . Enable Normal Mode operation by writing 10xxxxxx into the EN_MODE[1:0] bits in the CONTROL register (0x02). Normal Mode enables a 0 to 24mA current setting range with 125 μ A steps. Optionally, color settings and selections may be preset while in Shutdown Mode, so that the RGB modules ramp immediately to the desired colors upon enabling Normal Mode or Night Mode.

Night Mode

Enable Night Mode by writing 01xxxxxx into the EN_MODE[1:0] bits in the CONTROL register (0x02). In Night Mode, all Normal Mode LED current settings are divided by 16 for a 0 to 1.5mA current setting range with 7.8125 μ A steps. Note that fade ramps within Night Mode operate as normal but are still at the 7.8125 μ A resolution (same as normal mode). Also, note that the exponential fade engines allow fading between Normal and Night Modes.

Global Off Request and Shutdown (Standby) Mode

By default, the KTD2061/58/59/60 power up in Shutdown Mode when power is first applied to V_{CC} . After enabling Normal Mode or Night Mode, request a return to Shutdown Mode by writing 00xxxxxx into the EN_MODE[1:0] bits in the CONTROL register (0x02). Once requested, all LEDs first fade down to zero current (off) at the programmed fade-rate time-constant. Once all LEDs reach zero current, the KTD2061/58/59/60 automatically enter Shutdown (Standby) Mode to reduce quiescent current. In Shutdown Mode, the I²C interface and register contents are kept alive, so long as V_{CC} remains above the power-on reset threshold of 1.8V. Because a request for Shutdown first invokes a global fade ramp-down, certain lighting patterns, such as breathing patterns, are easily implemented by toggling between Normal Mode (or Night Mode) and Global Off Request.

Register Reset

Reset the registers to their default settings by writing 11xxxxxx into the EN_MODE[1:0] bits in the CONTROL register (0x02). After resetting, the CONTROL register reads back its default setting of 00000000.

BrightExtend™ Technology

Patented BrightExtend™ enhances low- V_{in} performance for applications using a 1s Li Ion battery, 3s alkaline/NiMH batteries, or 3.3V to 4V supply rail. The BE_EN bit in the CONTROL register (0x02) enables BrightExtend™. Once enabled, if dropout is detected for any current sink, the global scaling of all current sinks is reduced until dropout is removed. This makes use of the LED's V_f curve, where lower LED current results in lower V_f . During BrightExtend™, all the LEDs become slightly dimmer in order to preserve the RGB color balance and maintain power supply ripple rejection (PSRR). The effect of scaling the global LED current is almost imperceptible to the human eye. When or if dropout is reduced, the global scaling gradually recovers. Global scaling is also reset in Shutdown (Standby) Mode.

CoolExtend™ Technology

Proprietary CoolExtend™ simplifies thermal management. The CE_TEMP[1:0] bits in the CONTROL register (0x02) select from four maximum die temperature regulation settings. If the die temperature exceeds the CoolExtend™ setting, the global scaling of all current sinks is reduced until the excessive die temperature is

removed. During CoolExtend™, all the LEDs become slightly dimmer in order to reduce power dissipation in the current sinks. The effect of scaling the global LED current is almost imperceptible to the human eye. When or if die temperature is reduced, the global scaling gradually recovers. Global scaling is also reset in Shutdown (Standby) Mode.

Exponential Fade Rate

The KTD2061/58/59/60 include 36 internal, high-precision, fade engines for each LED to ramp the LED's current up or down when the LED is enabled/disabled or when the LED's current setting or color selection is changed. Each LED is independently ramped as soon as an enable/disable, current setting or color selection command is written via I²C for that LED. The fade rate is universal for all LEDs; however, it can be changed at any time, even in the middle of a fade ramp. Additionally, enable/disable or current setting/selection can be changed at any time, even in the middle of a fade ramp. The fade engines simply act as continuous-time smoothing filters.

The FADE_RATE[2:0] bits in the CONTROL register (0x02) select from eight fade rates. The fade rates range from very fast to very slow. The fade ramp steps are at 8μA resolution, which is 3072 steps for a full-scale ramp. This ensures ultra-smooth fading under all conditions, including very slow fades. Fading cannot be disabled, so if fading is not desired, use the fastest fade-rate, which appears as nearly instant to the human eye.

The fade ramp is not linear, but rather an exponential curve; therefore, the fade rates are expressed using their exponential time-constant. Unlike competing solutions, it is extremely simple to calculate the fade duration because the LED current is nearly settled in 3 time-constants and fully settled in 6 time-constants, regardless of the starting current or ending current. However, due to the logarithmic response of the human eye, perceived brightness seems to settle in ½ of a time-constant when increasing brightness and 4 to 6 time-constants when decreasing brightness. See Figure 3. For this reason, some lighting patterns, such as breathing, benefit from a slow time-constant to ramp up the current and a faster time-constant to ramp down the current.

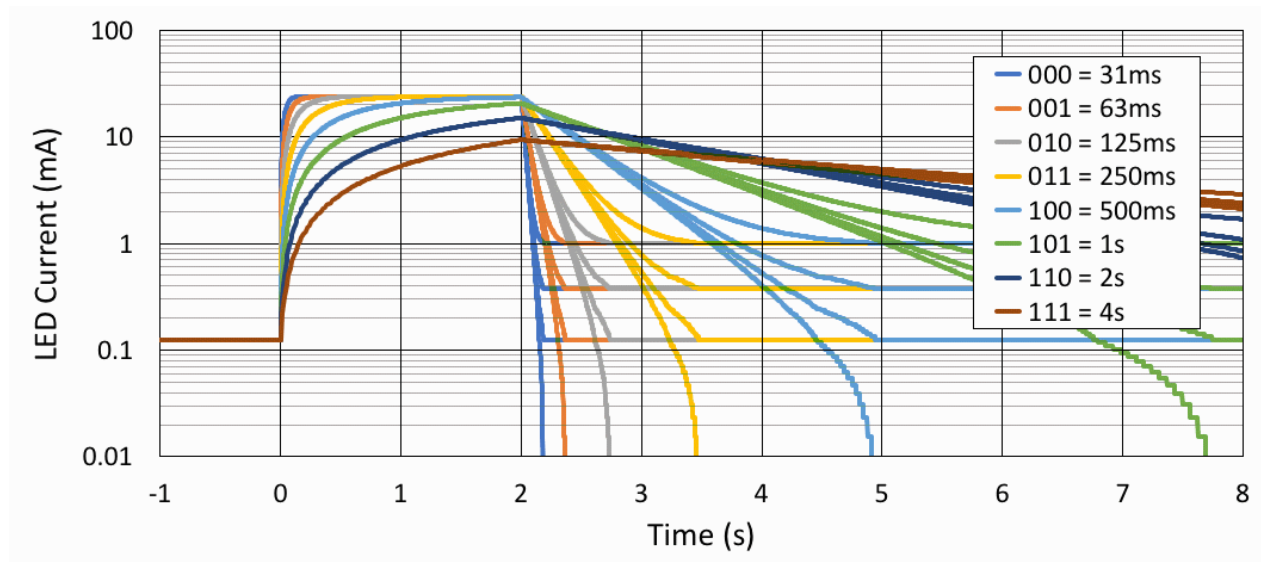

Figure 3. LED Brightness (current on log-scale) vs. Time vs. Fade Engine Time-Constant

The Color Setting Registers

The KTD2061/58/59/60 contain six registers (0x03 to 0x08) to set colors or define a color palette for a given lighting pattern. A color is set by programming a combination of red, green and blue LED currents. The IRED0, IGRN0 and IBLU0 registers (0x03 to 0x05) define Color 0, while the IRED1, IGRN1 and IBLU1 registers (0x06 to 0x08) define Color 1. These six current settings establish two specific colors, but they also define an 8-color palette obtained by mixing the Color 0 and Color 1 red, green and blue current levels, as described in *The Selection Registers* section below.

Setting Two Specific Colors

Set two specific colors (Color 0 and Color 1) when a lighting pattern contains two colors that must exactly match a specific target color for marketing purposes. In this case, there are 6 additional colors possible (and black is always possible), but these additional colors are whatever results after setting the two specific colors.

Setting an 8-Color Palette

Set an 8-color palette when a variety of simultaneous colors are needed in a lighting pattern. The focus is on defining a pleasing color palette with significant variety; therefore, it is typical to set a high current and a low current (or zero current) for each of the red, green and blue components of Color 0 and Color 1. The 8 colors are obtained by individually selecting between the high current and the low current for the red, green, and blue LEDs within each RGB module.

Of course, patterns may dynamically change the two specific colors or the 8-color palette during the pattern, whenever needed for the desired effect.

The Selection Registers

The KTD2061/58/59/60 contain six registers (0x09 to 0x0E) to select on/off and color for each RGB module individually. Each register controls two of the 12 RGB modules. For example, register ISEL34 controls two RGB modules: RGBC3 with the four MSBs and RGBC4 with the four LSBs.

Selecting Off (Black)

To turn off RGBC3, write 0xxxxxxx into ISEL34. To turn off RGBC4, write xxxx0xxx into ISEL34. When off is selected for an RGB module, it fades to zero current at the programmed fade-rate time-constant.

Selecting from the Two Specific Colors for an RGB Module

The selection registers are configured to easily support patterns with two specific colors. As an example, if the ISELA12 register is set to 1000xxxx, then the RGBA1 module is selecting the specific Color 0 from registers 0x03 to 0x05. But if the register is set to 1111xxxx, then the RGBA1 module is selecting the specific Color 1 from registers 0x06 to 0x08.

Selecting from the 8-Color Palette for an RGB Module

When using an 8-color palette, the selection registers work similarly to how they work when selecting from two specific colors. As an example, the ISELA12 register may be set to xxxx1000, xxxx1001, xxxx1010, xxxx1011, xxxx1100, xxxx1101, xxxx1110, xxxx1111, or xxxx0xxx for the RGBA2 module to select from eight different colors and off (black), respectively.

Most often, lighting patterns with motion dynamically change the Selection registers to implement the desired animation. Additionally, they may also dynamically change the Color Setting registers and the fade-rate to achieve complex lighting effects.

Turning Off All RGB Modules

When turning off all 12 RGB modules, it can be done in multiple ways:

1. Use the Color Setting registers (0x03 to 0x08) to set zero current for all R, G, and B LEDs. This requires writing to either 3 or all 6 of the Color Setting registers.
2. Use the Selection registers (0x09 to 0x0E) to select off for each RGB module. This requires writing to all 6 of the Selection registers.
3. Use the Global Off Request and Shutdown from the CONTROL register (0x02). See the *Global Off Request and Shutdown Mode* section of this datasheet. This requires writing to only 1 register.

Regardless which technique is used, the LEDs fade to zero current at the programmed fade-rate setting.

I²C Interface Description

I²C Serial Data Bus

The KTD2061/58/59/60 support the I²C bus protocol. A device that sends data onto the bus is defined as a transmitter, and a device receiving data as a receiver. The device that controls the bus is called a master, whereas the devices controlled by the master are known as slaves. A master device must generate the serial clock (SCL), control bus access and generate START and STOP conditions to control the bus. The KTD2061/58/59/60 operate as slaves on the I²C bus. Within the bus specifications, a standard mode (100kHz maximum clock rate) and a fast mode (400kHz maximum clock rate) are defined. The KTD2061/58/59/60 work in both modes. Connections to the bus are made through the open-drain I/O lines SDA and SCL.

The following bus protocol has been defined in Figure 4:

- Data transfer may be initiated only when the bus is not busy.
- During data transfer, the data line must remain stable whenever the clock line is HIGH. Changes in the data line while the clock line is high are interpreted as control signals.

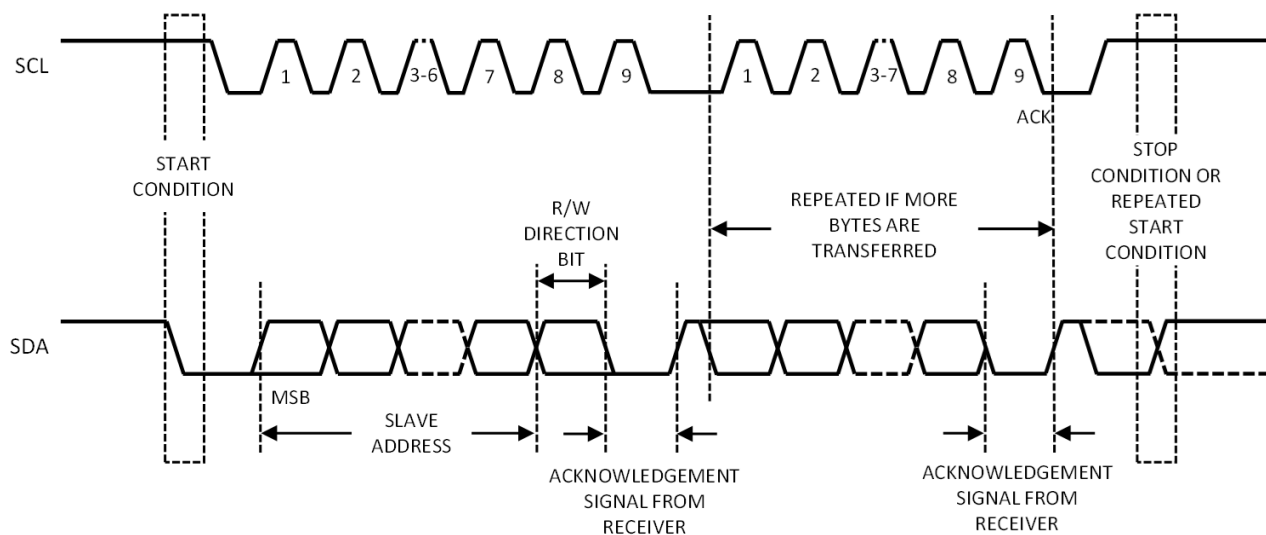

Figure 4. Data Transfer on I²C Serial Bus

Accordingly, the following bus conditions have been defined:

Bus Not Busy

Both data and clock lines remain HIGH.

Start Data Transfer

A change in the state of the data line, from HIGH to LOW, while the clock is HIGH, defines a START condition.

Stop Data Transfer

A change in the state of the data line, from LOW to HIGH, while the clock line is HIGH, defines the STOP condition.

Data Valid

The state of the data line represents valid data when, after a START condition, the data line is stable for the duration of the HIGH period of the clock signal. The data on the line must be changed during the LOW period of the clock signal. There is one clock pulse per bit of data.

Each data transfer is initiated with a START condition and terminated with a STOP condition. The number of data bytes transferred between START and STOP conditions are not limited and are determined by the master device. The information is transferred byte-wise and each receiver acknowledges with a ninth bit.

Acknowledge

Each receiving device, when addressed, is obliged to generate an acknowledge after the reception of each byte. The master device must generate an extra clock pulse that is associated with this acknowledge bit.

A device that acknowledges must pull down the SDA line during the acknowledge clock pulse in such a way that the SDA line is stable LOW during the HIGH period of the acknowledge-related clock pulse. Setup and hold times must also be considered.

The KTD2061 7-bit slave device address is 1101000 binary (0x68h). For alternate addresses or when using multiple parts on a single I²C bus, see the *Ordering Information* and the *I²C Slave Address* sections in this datasheet.

There are two kinds of I²C data transfer cycles: write cycle and read cycle.

I²C Write Cycle

For I²C write cycle, data is transferred from a master to a slave. The first byte transmitted is the 7-bit slave address plus one bit of '0' for write. Next follows a number of data bytes. The slave returns an acknowledge bit after each received byte. Data is transferred with the most significant bit (MSB) first. Figure 5 shows the sequence of the I²C write cycle.

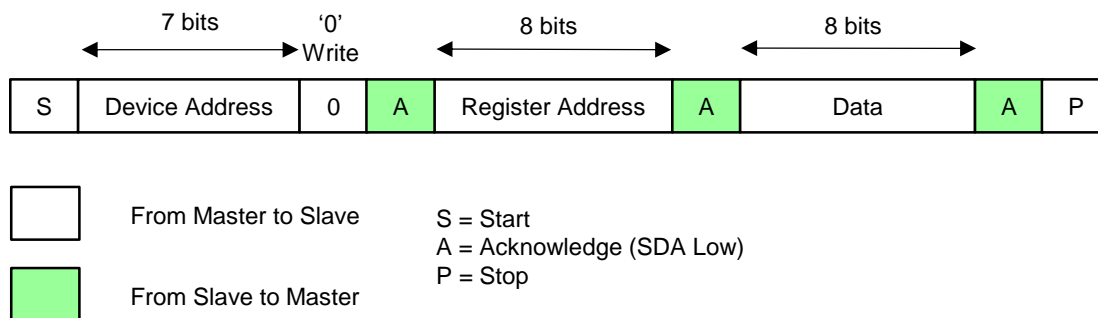

Figure 5. I²C Write Cycle

I²C Write Cycle Steps:

- Master generates start condition.
- Master sends 7-bit slave address (1101000 for KTD2061) and 1-bit data direction '0' for write.
- Slave sends acknowledge if the slave address is matched.
- Master sends 8-bit register address.
- Slave sends acknowledge.
- Master sends 8-bit data for that addressed register.
- Slave sends acknowledge.
- If master sends more data bytes, the register address will be incremented by one after each acknowledge.
- Master generate stop condition to finish the write cycle.

I²C Read Cycle

For I²C read cycle, data is transferred from a slave to a master. But to start the read cycle, master needs to write the register address first to define which register data to read. Figure 6 shows the steps of the I²C read cycle.

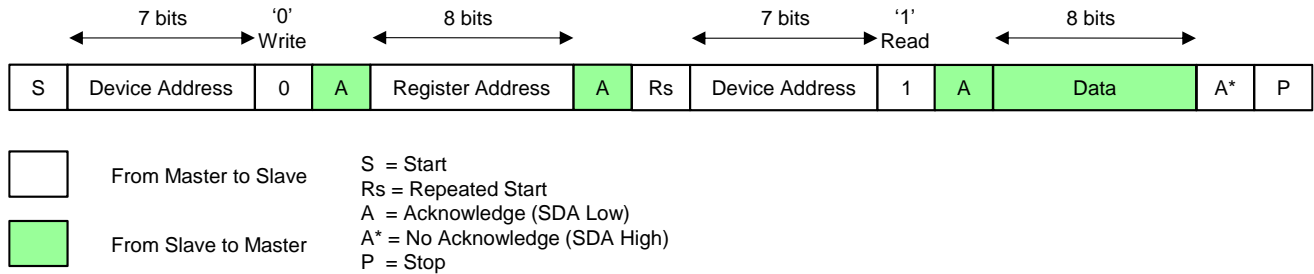

Figure 6. I²C Read Cycle

I²C Read Cycle Steps:

- Master generates start condition.
- Master sends 7-bit slave address (1101000 for KTD2061) and 1-bit data direction '0' for write.
- Slave sends acknowledge if the slave address is matched.
- Master sends 8-bit register address.
- Slave sends acknowledge.
- Master generates repeated start condition.
- Master sends 7-bit slave address (1101000 for KTD2061) and 1-bit data direction '1' for read.
- Slave sends acknowledge if the slave address is matched.
- Slave sends the data byte of that addressed register.
- If master sends acknowledge, the register address will be incremented by one after each acknowledge and the slave will continue to send the data for the updated addressed register.
- If master sends no acknowledge, the slave will stop sending the data.
- Master generate stop condition to finish the read cycle.

I²C Registers

I²C Slave Address

Options ⁸	7-Bit Address	Write Address	Read Address	Bits
				7 6 5 4 3 2 1 0
KTD2061 (default)	0x68	0xD0	0xD1	1 1 0 1 0 0 0 <i>R/W</i>
KTD2060 (alternate)	0x6B	0xD6	0xD7	1 1 0 1 0 1 1 <i>R/W</i>
KTD2059 (alternate)	0x6A	0xD4	0xD5	1 1 0 1 0 1 0 <i>R/W</i>
KTD2058 (alternate)	0x69	0xD2	0xD3	1 1 0 1 0 0 1 <i>R/W</i>

I²C Register Map

Hex Address	Name	Type	Access	Default Reset	B7	B6	B5	B4	B3	B2	B1	B0	
0x00	ID	Data	R	1010 0100	VENDOR[2:0]			DIE_ID[4:0]					
0x01	MONITOR	Status	R	0011 0000	DIE_REV[3:0]				SC_STAT	BE_STAT	CE_STAT	UV/OT_STAT	
0x02	CONTROL	Config	R/W	0000 0000	EN_MODE[1:0]	BE_EN	CE_TEMP[1:0]	FADE_RATE[2:0]					
0x03	IREDO	Config	R/W	0010 1000	IREO_SET0[7:0]								
0x04	IGRN0	Config	R/W	0010 1000	IGRN_SET0[7:0]								
0x05	IBLU0	Config	R/W	0010 1000	IBLU_SET0[7:0]								
0x06	IREO1	Config	R/W	0110 0000	IREO_SET1[7:0]								
0x07	IGRN1	Config	R/W	0110 0000	IGRN_SET1[7:0]								
0x08	IBLU1	Config	R/W	0110 0000	IBLU_SET1[7:0]								
0x09	I SELA12	Config	R/W	0000 0000	ENA1	RGBA1_SEL[2:0]		ENA2	RGBA2_SEL[2:0]				
0x0A	I SELA34	Config	R/W	0000 0000	ENA3	RGBA3_SEL[2:0]		ENA4	RGBA4_SEL[2:0]				
0x0B	I SELB12	Config	R/W	0000 0000	ENB1	RBB1_SEL[2:0]		ENB2	RBB2_SEL[2:0]				
0x0C	I SELB34	Config	R/W	0000 0000	ENB3	RBB3_SEL[2:0]		ENB4	RBB4_SEL[2:0]				
0x0D	I SELC12	Config	R/W	0000 0000	ENC1	RGBC1_SEL[2:0]		ENC2	RGBC2_SEL[2:0]				
0x0E	I SELC34	Config	R/W	0000 0000	ENC3	RGBC3_SEL[2:0]		ENC4	RGBC4_SEL[2:0]				

ID Data Register

Register Address 0x00

Bit	Name	Access	Default Reset	Description
7:5	VENDOR[2:0]	R	101	Vendor Identification 101 = Kinetic Technologies
4:0	DIE_ID[4:0]	R	TBD	Die Type Identification 0 0100 = KTD2061/58/59/60

8. For Alternate 1/2 Slave Addresses, please contact a Kinetic Technologies representative.

MONITOR Status Register

Register Address 0x01

Bit	Name	Access	Default Reset	Description
7:4	DIE_REV[3:0]	R	0011	Die Revision Identification 0001 = prototype 0010 = engineering samples 0011 = mass production
3	SC_STAT	R	0	Short-Circuit Protection Status 0 = no LED_n output is shorted to ground 1 = at least one LED_n output is shorted to ground
2	BE_STAT	R	0	BrightExtend™ Dropout Status 0 = there is no dropout, or BrightExtend™ is not enabled 1 = there is dropout, and BrightExtend™ is enabled and active
1	COOL_STAT	R	0	CoolExtend™ Die Temperature Status 0 = the die is not hot, and CoolExtend™ is not active 1 = the die is hot, and CoolExtend™ is active
0	UV/OT_STAT	R	0	V _{CC} Under-Voltage Lockout or Over Temperature Shutdown Status 0 = V _{CC} is above V _{UVLO} , and the die is not in thermal shutdown 1 = V _{CC} is between V _{POR} and V _{UVLO} , or the die is in thermal shutdown

CONTROL Configuration Register

Register Address 0x02

Bit	Name	Access	Default Reset	Description
7:6	EN_MODE[1:0]	R/W	00	Enable Mode and Reset 00 = global off request (fade all LEDs to zero and then shutdown) 01 = enable Night Mode (0 to 1.5mA range) 10 = enable Normal Mode (0 to 24mA range) 11 = reset all registers to default settings
5	BE_EN	R/W	0	BrightExtend™ Enable 0 = disabled 1 = enabled
4:3	CE_TEMP[1:0]	R/W	00	CoolExtend™ Temperature Setting 00 = 135°C rising 01 = 120°C 10 = 105°C 11 = 90°C
2:0	FADE_RATE[2:0]	R/W	000	Fade Rate Exponential Time-Constant Setting 000 = 31ms 001 = 63ms 010 = 125ms 011 = 250ms 100 = 500ms 101 = 1s 110 = 2s 111 = 4s

IRED0 Color Configuration Register

Register Address 0x03

Bit	Name	Access	Default Reset	Description
7:0	IRED_SET0[7:0]	R/W	0010 1000	Red Current Setting 0 0000 0000 = 0μA 0000 0001 = 125μA . . 0010 1000 = 5mA . . 1100 0000 = 24mA 1100 0001 = 24mA (reads back as 1100 0000) . . 1111 1111 = 24mA (reads back as 1100 0000)

IGRN0 Color Configuration Register

Register Address 0x04

Bit	Name	Access	Default Reset	Description
7:0	IGRN_SET0[7:0]	R/W	0010 1000	Green Current Setting 0 0000 0000 = 0μA 0000 0001 = 125μA . . 0010 1000 = 5mA . . 1100 0000 = 24mA 1100 0001 = 24mA (reads back as 1100 0000) . . 1111 1111 = 24mA (reads back as 1100 0000)

IBLU0 Color Configuration Register

Register Address 0x05

Bit	Name	Access	Default Reset	Description
7:0	IBLU_SET0[7:0]	R/W	0010 1000	Blue Current Setting 0 0000 0000 = 0μA 0000 0001 = 125μA . . 0010 1000 = 5mA . . 1100 0000 = 24mA 1100 0001 = 24mA (reads back as 1100 0000) . . 1111 1111 = 24mA (reads back as 1100 0000)

IRED1 Color Configuration Register

Register Address 0x06

Bit	Name	Access	Default Reset	Description
7:0	IRED_SET1[7:0]	R/W	0110 0000	Red Current Setting 1 0000 0000 = 0μA 0000 0001 = 125μA . . 0110 0000 = 12mA . . 1100 0000 = 24mA 1100 0001 = 24mA (reads back as 1100 0000) . . 1111 1111 = 24mA (reads back as 1100 0000)

IGRN1 Color Configuration Register

Register Address 0x07

Bit	Name	Access	Default Reset	Description
7:0	IGRN_SET1[7:0]	R/W	0110 0000	Green Current Setting 1 0000 0000 = 0μA 0000 0001 = 125μA . . 0110 0000 = 12mA . . 1100 0000 = 24mA 1100 0001 = 24mA (reads back as 1100 0000) . . 1111 1111 = 24mA (reads back as 1100 0000)

IBLU1 Color Configuration Register

Register Address 0x08

Bit	Name	Access	Default Reset	Description
7:0	IBLU_SET1[7:0]	R/W	0110 0000	Blue Current Setting 1 0000 0000 = 0μA 0000 0001 = 125μA . . 0110 0000 = 12mA . . 1100 0000 = 24mA 1100 0001 = 24mA (reads back as 1100 0000) . . 1111 1111 = 24mA (reads back as 1100 0000)

ISELA12 Selection Configuration Register

Register Address 0x09

Bit	Name	Access	Default Reset	Description
7	ENA1	R/W	0	Enable RGB with anode connected to LEDA1 pin 0 = use 0µA for these LEDs (includes fade to 0µA) 1 = use the settings selected by RGBA1_SEL[2:0]
6:4	RGBA1_SEL[2:0]	R/W	000	Current Selection for RGB with anode connected to LEDA1 pin 0XX = I _{LEDA3} selects IRED_SET0[7:0] 1XX = I _{LEDA3} selects IRED_SET1[7:0] X0X = I _{LEDA2} selects IGRN_SET0[7:0] X1X = I _{LEDA2} selects IGRN_SET1[7:0] XX0 = I _{LEDA4} selects IBLU_SET0[7:0] XX1 = I _{LEDA4} selects IBLU_SET1[7:0]
3	ENA2	R/W	0	Enable RGB with anode connected to LEDA2 pin 0 = use 0µA for these LEDs (includes fade to 0µA) 1 = use the settings selected by RGBA2_SEL[2:0]
2:0	RGBA2_SEL[2:0]	R/W	000	Current Selection for RGB with anode connected to LEDA2 pin 0XX = I _{LEDA4} selects IRED_SET0[7:0] 1XX = I _{LEDA4} selects IRED_SET1[7:0] X0X = I _{LEDA3} selects IGRN_SET0[7:0] X1X = I _{LEDA3} selects IGRN_SET1[7:0] XX0 = I _{LEDA1} selects IBLU_SET0[7:0] XX1 = I _{LEDA1} selects IBLU_SET1[7:0]

ISELA34 Selection Configuration Register

Register Address 0x0A

Bit	Name	Access	Default Reset	Description
7	ENA3	R/W	0	Enable RGB with anode connected to LEDA3 pin 0 = use 0µA for these LEDs (includes fade to 0µA) 1 = use the settings selected by RGBA3_SEL[2:0]
6:4	RGBA3_SEL[2:0]	R/W	000	Current Selection for RGB with anode connected to LEDA3 pin 0XX = I _{LEDA1} selects IRED_SET0[7:0] 1XX = I _{LEDA1} selects IRED_SET1[7:0] X0X = I _{LEDA4} selects IGRN_SET0[7:0] X1X = I _{LEDA4} selects IGRN_SET1[7:0] XX0 = I _{LEDA2} selects IBLU_SET0[7:0] XX1 = I _{LEDA2} selects IBLU_SET1[7:0]
3	ENA4	R/W	0	Enable RGB with anode connected to LEDA4 pin 0 = use 0µA for these LEDs (includes fade to 0µA) 1 = use the settings selected by RGBA4_SEL[2:0]
2:0	RGBA4_SEL[2:0]	R/W	000	Current Selection for RGB with anode connected to LEDA4 pin 0XX = I _{LEDA2} selects IRED_SET0[7:0] 1XX = I _{LEDA2} selects IRED_SET1[7:0] X0X = I _{LEDA1} selects IGRN_SET0[7:0] X1X = I _{LEDA1} selects IGRN_SET1[7:0] XX0 = I _{LEDA3} selects IBLU_SET0[7:0] XX1 = I _{LEDA3} selects IBLU_SET1[7:0]

ISELB12 Selection Configuration Register

Register Address 0x0B

Bit	Name	Access	Default Reset	Description
7	ENB1	R/W	0	Enable RGB with anode connected to LEDB1 pin 0 = use 0µA for these LEDs (includes fade to 0µA) 1 = use the settings selected by RGG1_SEL[2:0]
6:4	RGG1_SEL[2:0]	R/W	000	Current Selection for RGB with anode connected to LEDB1 pin 0XX = I _{LEDB3} selects IRED_SET0[7:0] 1XX = I _{LEDB3} selects IRED_SET1[7:0] X0X = I _{LEDB2} selects IGRN_SET0[7:0] X1X = I _{LEDB2} selects IGRN_SET1[7:0] XX0 = I _{LEDB4} selects IBLU_SET0[7:0] XX1 = I _{LEDB4} selects IBLU_SET1[7:0]
3	ENB2	R/W	0	Enable RGB with anode connected to LEDB2 pin 0 = use 0µA for these LEDs (includes fade to 0µA) 1 = use the settings selected by RGG2_SEL[2:0]
2:0	RGG2_SEL[2:0]	R/W	000	Current Selection for RGB with anode connected to LEDB2 pin 0XX = I _{LEDB4} selects IRED_SET0[7:0] 1XX = I _{LEDB4} selects IRED_SET1[7:0] X0X = I _{LEDB3} selects IGRN_SET0[7:0] X1X = I _{LEDB3} selects IGRN_SET1[7:0] XX0 = I _{LEDB1} selects IBLU_SET0[7:0] XX1 = I _{LEDB1} selects IBLU_SET1[7:0]

ISELB34 Selection Configuration Register

Register Address 0x0C

Bit	Name	Access	Default Reset	Description
7	ENB3	R/W	0	Enable RGB with anode connected to LEDB3 pin 0 = use 0µA for these LEDs (includes fade to 0µA) 1 = use the settings selected by RGG3_SEL[2:0]
6:4	RGG3_SEL[2:0]	R/W	000	Current Selection for RGB with anode connected to LEDB3 pin 0XX = I _{LEDB1} selects IRED_SET0[7:0] 1XX = I _{LEDB1} selects IRED_SET1[7:0] X0X = I _{LEDB4} selects IGRN_SET0[7:0] X1X = I _{LEDB4} selects IGRN_SET1[7:0] XX0 = I _{LEDB2} selects IBLU_SET0[7:0] XX1 = I _{LEDB2} selects IBLU_SET1[7:0]
3	ENB4	R/W	0	Enable RGB with anode connected to LEDB4 pin 0 = use 0µA for these LEDs (includes fade to 0µA) 1 = use the settings selected by RGG4_SEL[2:0]
2:0	RGG4_SEL[2:0]	R/W	000	Current Selection for RGB with anode connected to LEDB4 pin 0XX = I _{LEDB2} selects IRED_SET0[7:0] 1XX = I _{LEDB2} selects IRED_SET1[7:0] X0X = I _{LEDB1} selects IGRN_SET0[7:0] X1X = I _{LEDB1} selects IGRN_SET1[7:0] XX0 = I _{LEDB3} selects IBLU_SET0[7:0] XX1 = I _{LEDB3} selects IBLU_SET1[7:0]

ISEL12 Selection Configuration Register

Register Address 0x0D

Bit	Name	Access	Default Reset	Description
7	ENC1	R/W	0	Enable RGB with anode connected to LEDC1 pin 0 = use 0µA for these LEDs (includes fade to 0µA) 1 = use the settings selected by RGBC1_SEL[2:0]
6:4	RGBC1_SEL[2:0]	R/W	000	Current Selection for RGB with anode connected to LEDC1 pin 0XX = I _{LEDC3} selects IRED_SET0[7:0] 1XX = I _{LEDC3} selects IRED_SET1[7:0] X0X = I _{LEDC2} selects IGRN_SET0[7:0] X1X = I _{LEDC2} selects IGRN_SET1[7:0] XX0 = I _{LEDC4} selects IBLU_SET0[7:0] XX1 = I _{LEDC4} selects IBLU_SET1[7:0]
3	ENC2	R/W	0	Enable RGB with anode connected to LEDC2 pin 0 = use 0µA for these LEDs (includes fade to 0µA) 1 = use the settings selected by RGBC2_SEL[2:0]
2:0	RGBC2_SEL[2:0]	R/W	000	Current Selection for RGB with anode connected to LEDC2 pin 0XX = I _{LEDC4} selects IRED_SET0[7:0] 1XX = I _{LEDC4} selects IRED_SET1[7:0] X0X = I _{LEDC3} selects IGRN_SET0[7:0] X1X = I _{LEDC3} selects IGRN_SET1[7:0] XX0 = I _{LEDC1} selects IBLU_SET0[7:0] XX1 = I _{LEDC1} selects IBLU_SET1[7:0]

ISEL34 Selection Configuration Register

Register Address 0x0E

Bit	Name	Access	Default Reset	Description
7	ENC3	R/W	0	Enable RGB with anode connected to LEDC3 pin 0 = use 0µA for these LEDs (includes fade to 0µA) 1 = use the settings selected by RGBC3_SEL[2:0]
6:4	RGBC3_SEL[2:0]	R/W	000	Current Selection for RGB with anode connected to LEDC3 pin 0XX = I _{LEDC1} selects IRED_SET0[7:0] 1XX = I _{LEDC1} selects IRED_SET1[7:0] X0X = I _{LEDC4} selects IGRN_SET0[7:0] X1X = I _{LEDC4} selects IGRN_SET1[7:0] XX0 = I _{LEDC2} selects IBLU_SET0[7:0] XX1 = I _{LEDC2} selects IBLU_SET1[7:0]
3	ENC4	R/W	0	Enable RGB with anode connected to LEDC4 pin 0 = use 0µA for these LEDs (includes fade to 0µA) 1 = use the settings selected by RGBC4_SEL[2:0]
2:0	RGBC4_SEL[2:0]	R/W	000	Current Selection for RGB with anode connected to LEDC4 pin 0XX = I _{LEDC2} selects IRED_SET0[7:0] 1XX = I _{LEDC2} selects IRED_SET1[7:0] X0X = I _{LEDC1} selects IGRN_SET0[7:0] X1X = I _{LEDC1} selects IGRN_SET1[7:0] XX0 = I _{LEDC3} selects IBLU_SET0[7:0] XX1 = I _{LEDC3} selects IBLU_SET1[7:0]

Applications Information

Input Bypass Capacitor

Choose an input capacitor with voltage rating of 6.3V or more, 10 μ F total nominal capacitance or more, and 1608M (0603) case-size or larger. Larger values and larger case-size provide more effective capacitance when considering the DC bias derating characteristic of the capacitor.

Additional Input Bulk Capacitance

Note that if the PCB's input voltage is supplied through a connector or a cable, add additional bypass capacitance where V_{IN} first arrives to the PCB to control input ripple and ringing. The Panasonic tantalum-polymer PosCap in 47 μ F to 150 μ F range is recommended. If this is too large or thick for the application, use two or three 22 μ F ceramic capacitors in parallel.

RGB LED Selection

Choose RGB modules with suitable color, brightness, and power dissipation to handle the requirements of the application. The LEDs must have reverse voltage rating of $V_R = 5V$ or more. Do not use RGB modules with integrated Zener diode protection clamps that do not allow reverse voltage, as these are incompatible with the multiplexing in the KTD2061/58/59/60. Additionally, the LEDs should have minimum operating current of 2mA or less.

Recommended RGB LEDs

Manufacturer	Model #	Luminous Intensity (typ)	Size
Cree	CLV1L-FKB Series	Red = 673mcd Green = 1260mcd Blue = 266mcd	PLCC-4 3.2 x 2.8 x 1.9mm
Everlight	19-337C/RSBHGHC-A88/4T(KNT) 19-337C/RSBHGHC-A88/4T	Red = 565mcd Green = 1270mcd Blue = 255mcd	SMD-6 1.6 x 1.6 x 0.5mm
Kingbright ⁹	APTF1616SEEZ Series	Red = 110mcd Green = 280mcd Blue = 70mcd	SMD-4 1.6 x 1.6 x 0.7mm
Lite-On	LTST-C19HE1WT	Red = 92mcd Green = 230mcd Blue = 71mcd	SMD-4 1.6 x 1.6 x 0.35mm
SunLED ⁹	XZMDKDGCB110W	Red = 79mcd Green = 278mcd Blue = 69mcd	SMD-4 1.6 x 1.6 x 0.7mm
Würth Elektronik	WL-SFCW SMD 150066M173000	Red = 70mcd Green = 360mcd Blue = 80mcd	SMD-4 1.6 x 1.6 x 0.4mm

Please tell the LED manufacturer that you are using the KTD2061/58/59/60 RGB LED driver IC. Note that the Everlight RGB has high-intensity in small package size at good value and is therefore chosen for the KTD2061 Evaluation Board.

9. These RGB LEDs are pin-to-pin.

LED Current Temperature Derating

Driving LED at high temperature can accelerate the LED's degradation. Consult the LED vendor for Forward Current Derating Curve, similar to Figure 7 as an example. Set the operating point of the LED on or below the curve to avoid any thermal degradation.

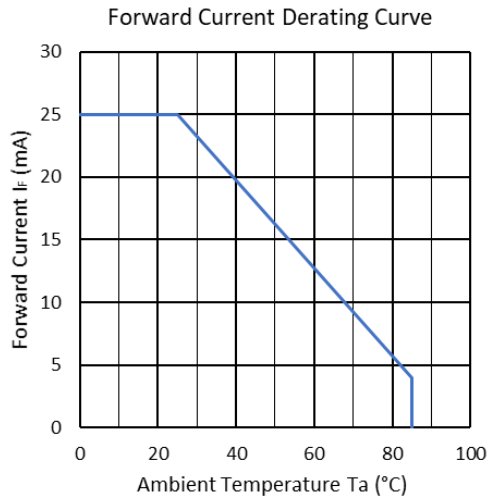

Figure 7. Forward Current Derating Curve

LED Safe Pulse-Current Rating

The LED pulse current rating should be 4x higher than the average forward current required in the application. For example, an LED with forward current rating of $I_f = 25\text{mA}$ is usually rated for a peak forward current of $I_{FP} = 100\text{mA}$. The conditions of this rating are usually Duty = 10% @ 1kHz. However, the KTD2061/58/59/60 multiplexing is at Duty = 25% @ 23kHz. In most cases, the higher duty is counteracted by the higher frequency such that the $I_{FP} = 100\text{mA}$ is similar under both conditions. Consult with the LED manufacturer for a graph of permissible pulse handling capability showing pulse current I_{FP} vs. pulse duration t_P vs. duty. For the KTD2061/58/59/60, $t_P = 10.9\mu\text{s}$ and duty = 0.25. From the graph, the maximum I_{FP} can be found for the red, green and blue LEDs. Once the upper limit is found, program the KTD2061/58/59/60 current settings to no higher than $I_{FP}/4$.

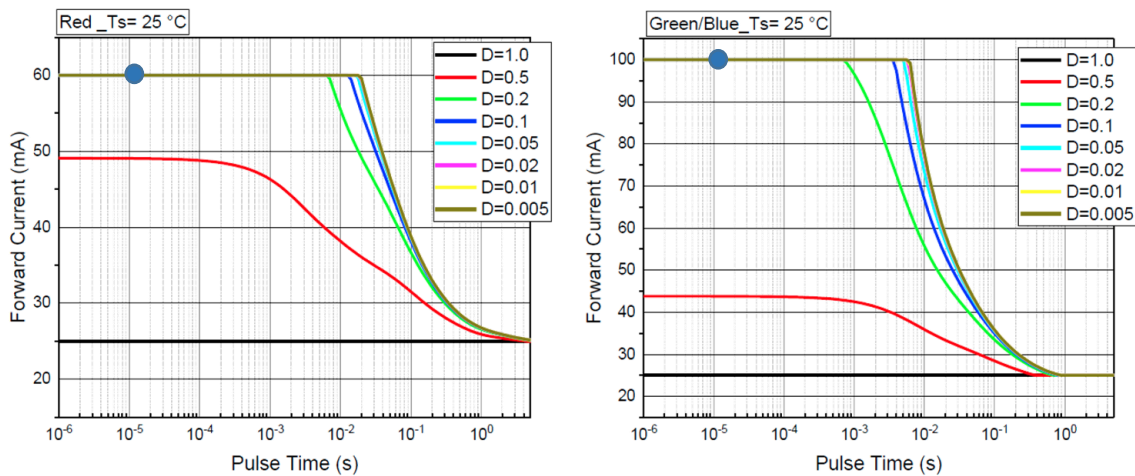

Figure 8. Permissible Pulse Handling Capability (courtesy of Everlight Corp.)

De-Ghosting

Ghosting is defined as unintended light glow emitting from LEDs that are supposed to be off. It is an inherent artifact when multiplexing LEDs, especially when using LEDs that have very different Vf. In the case of RGB LEDs, the red LED Vf is much lower than the green and blue Vf.

Many lighting patterns do not manifest any ghosting at all – for example, breathing patterns. But for patterns with ghosting, the KTD2061/58/59/60 include proprietary circuitry to reduce the ghosting artifacts. Even so, some patterns are still susceptible to ghosting. If the diffuser is not sufficiently hiding all ghosting, there are two simple solutions:

1. **Software Solution** – Modify only the software patterns that show visible ghosting. In general, if one RGB on a bus is enabled as blue only (or green only) at a bright current setting, other RGBs on the same bus that are supposed to be off may exhibit ghosting. As an example, if intending bright blue in one RGB, there may be red and/or green glow in other nearby RGBs. One improvement is to lower the current setting of the bright blue RGB. Another improvement is to use slightly pastel blue instead of pure blue by turning on just a small amount of red and green in the bright blue RGB. Usually, combine both software improvements to completely eliminate the ghosting. By example, instead of setting the blue RGB with current settings of red = 0mA, green = 0mA, and blue = 24mA, try current settings of red = 0.5mA, green = 0.5mA, and blue = 18mA.
2. **Hardware Solution** – Insert a small signal diode, such as 1N4148, in series with each red LED to effectively increase its Vf. The KTD2061/58/59/60 EV Kit has an unpopulated 1608M (0603) footprint in series with each red LED. By default, these footprints are each shorted with a thin trace. Cut these traces with a knife or small grinder before optionally populating low-cost 1N4148 diodes in SOD523 package.

Pattern Generation using System Software

A User Guide is available for the KTD2061 that demonstrates how to create multiple software patterns. The examples are written as parameterized, reusable functions in Python script. These functions are easy to translate into other software languages.

Recommended PCB Layout

See Figure 9 for an example PCB layout. When laying out a PCB, follow the below steps in sequence:

1. A 2-layer or higher PCB is recommended for robust ground connections and for thermal power dissipation with the exposed paddle package.
2. Place multiple vias directly from the exposed paddle landing pattern to the ground plane.
3. Connect each GND pin to the exposed paddle directly under the IC on layer 1. Optionally, add an additional connection to the ground plane at each GND pin with a via that is not underneath the IC.
4. The VCC pin must be connected to the VIN pins. Place the input bypass capacitor as close to the VIN and VCC pins as possible. Connect the ground terminal of the capacitor to the ground plane using multiple vias. Connect the VIN terminal of the capacitor to the power plane or trace, using multiple vias if applicable.
5. If power is supplied through a cable/connector, add additional bulk bypass capacitance near the connector where the power first arrives to the PCB in order to control input ripple and ringing.
6. Route the output traces and vias with suitable thickness, as necessary for the peak currents. Up to 288mA (96mA x 3LEDs) can flow in the output traces, but most applications use less peak current due to LED temperature derating and LED pulse current ratings.

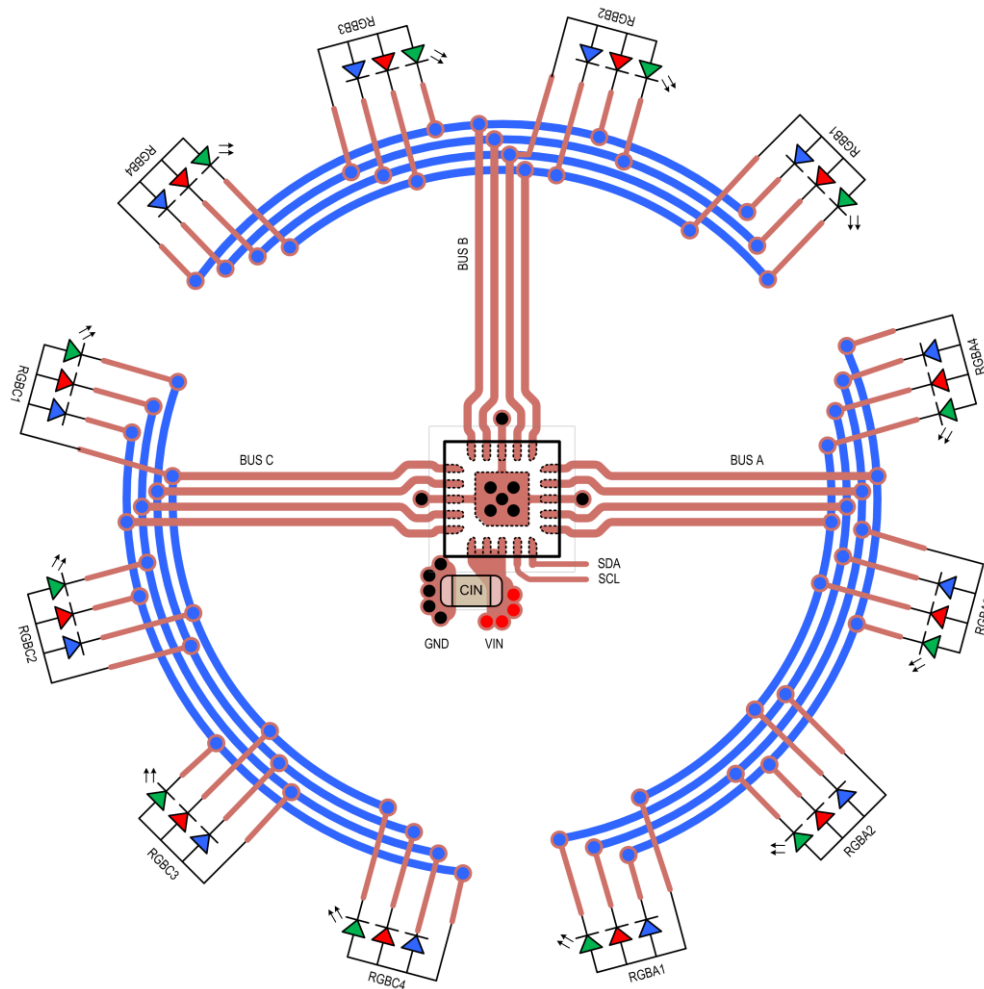
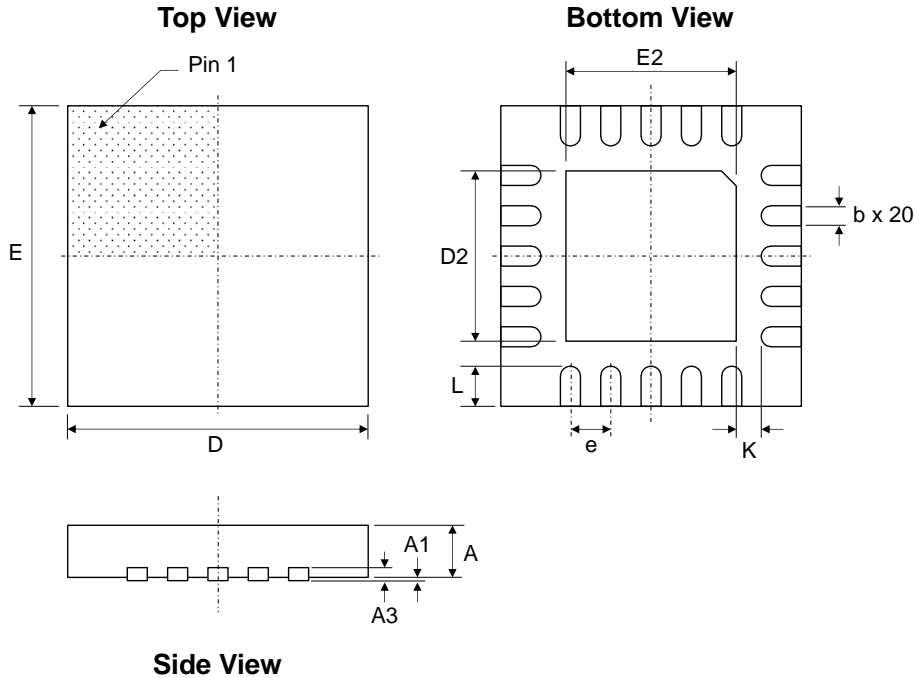

Figure 9. Recommended PCB Layout (ring-light example)

Packaging Information

UQFN33-20 (3.00mm x 3.00mm x 0.52mm)



Dimension	mm		
	Min.	Typ.	Max.
A	0.45	0.52	0.58
A1	0.00	0.02	0.05
A3	0.127 REF		
b	0.13	0.19	0.25
D	2.90	3.00	3.10
D2	1.65	1.70	1.75
E	2.90	3.00	3.10
E2	1.65	1.70	1.75
e	0.40 BSC		
L	0.35	0.40	0.45
K	0.20	0.25	0.30

Recommended Footprint

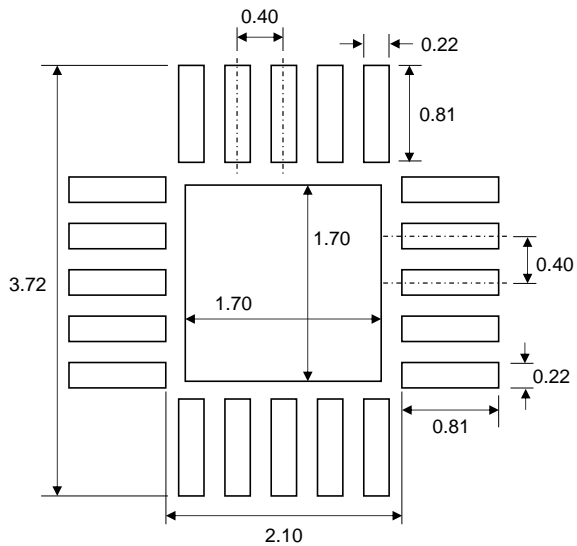

Kinetic Technologies cannot assume responsibility for use of any circuitry other than circuitry entirely embodied in a Kinetic Technologies product. No intellectual property or circuit patent licenses are implied. Kinetic Technologies reserves the right to change the circuitry and specifications without notice at any time.

Looking for pricing, stock, or lifecycle information?

Click below to explore more details on WIN SOURCE:

 [View KTD2061EUAC-TR on WIN SOURCE](#)

 [Kinetic Information](#)

Optimize Your Supply Chain with WIN SOURCE Solutions

-  Global Sourcing Solution
-  Obsolete Management
-  Cost Control Management
-  Shortage Management
-  Alternative Solution
-  Excess Inventory Management