



**THE DATASHEET OF
CYW43569PKFFBG**





The following document contains information on Cypress products. Although the document is marked with the name “Broadcom”, the company that originally developed the specification, Cypress will continue to offer these products to new and existing customers.

CONTINUITY OF SPECIFICATIONS

There is no change to this document as a result of offering the device as a Cypress product. Any changes that have been made are the result of normal document improvements and are noted in the document history page, where supported. Future revisions will occur when appropriate, and changes will be noted in a document history page.

CONTINUITY OF ORDERING PART NUMBERS

Cypress continues to support existing part numbers. To order these products, please use only the Ordering Part Numbers listed in this document.

FOR MORE INFORMATION

Please visit our website at www.cypress.com or contact your [local sales office](#) for additional information about Cypress products and services.

OUR CUSTOMERS

Cypress is for true innovators – in companies both large and small.

Our customers are smart, aggressive, out-of-the-box thinkers who design and develop game-changing products that revolutionize their industries or create new industries with products and solutions that nobody ever thought of before.

ABOUT CYPRESS

Founded in 1982, Cypress is the leader in advanced embedded system solutions for the world’s most innovative automotive, industrial, home automation and appliances, consumer electronics and medical products. Cypress’s programmable systems-on-chip, general-purpose microcontrollers, analog ICs, wireless and USB-based connectivity solutions and reliable, high-performance memories help engineers design differentiated products and get them to market first.

Cypress is committed to providing customers with the best support and engineering resources on the planet enabling innovators and out-of-the-box thinkers to disrupt markets and create new product categories in record time. To learn more, go to www.cypress.com.

Single-Chip 5G WiFi IEEE 802.11ac 2 × 2 MAC/Baseband/ Radio with Integrated Bluetooth 4.1 + EDR

GENERAL DESCRIPTION

The Broadcom® BCM43569 is a complete dual-band (2.4 GHz and 5 GHz) 5G WiFi 2 × 2 MIMO MAC/PHY/radio system-on-a-chip. This 5G WiFi single-chip device provides a high level of integration with a dual-stream IEEE 802.11ac MAC/baseband/radio and Bluetooth 4.1 + EDR. In IEEE 802.11ac mode, the WLAN operation supports rates of MCS0–MCS9 (up to 256 QAM) in 20 MHz, 40 MHz, and 80 MHz channels for data rates up to 867 Mbps in 5 GHz band. In addition, all the IEEE 802.11a/b/g/n rates are supported. Included on-chip are 2.4 GHz and 5 GHz transmitter power amplifiers and receiver low-noise amplifiers.

The BCM43569 integrates several peripheral interfaces including USB 2.0 coexistence, serial Flash, SPROM, JTAG, UART, and GPIO. For the Bluetooth section, the host interface options are a high-speed 4-wire UART and USB 2.0 full-speed (12 Mbps).

The BCM43569 uses advanced design techniques and process technology to reduce active and idle power, and includes an embedded power management unit that simplifies the system power topology. The BCM43569 implements highly sophisticated enhanced collaborative coexistence hardware mechanisms and algorithms that ensure that WLAN and Bluetooth collaboration is optimized.

FEATURES

IEEE 802.11X Key Features

- IEEE 802.11ac Draft compliant.
- Dual-stream spatial multiplexing up to 867 Mbps data rate.
- Supports 20, 40, and 80 MHz channels with optional SGI (256 QAM modulation in 5 GHz).
- Full IEEE 802.11a/b/g/n legacy compatibility with enhanced performance.
- TX and RX low-density parity check (LDPC) support for improved range and power efficiency.
- Supports IEEE 802.11ac/n beamforming.
- On-chip power amplifiers and low-noise amplifiers for both bands.
- Supports various RF front-end architectures including:
 - Three-antennas design: WLAN Core0, WLAN Core1, and BT antenna
 - Two antennas with WLAN diversity and a shared Bluetooth antenna.
- An internal fractional nPLL allows support for a wide range of reference clock frequencies.

Figure 1: Functional Block Diagram

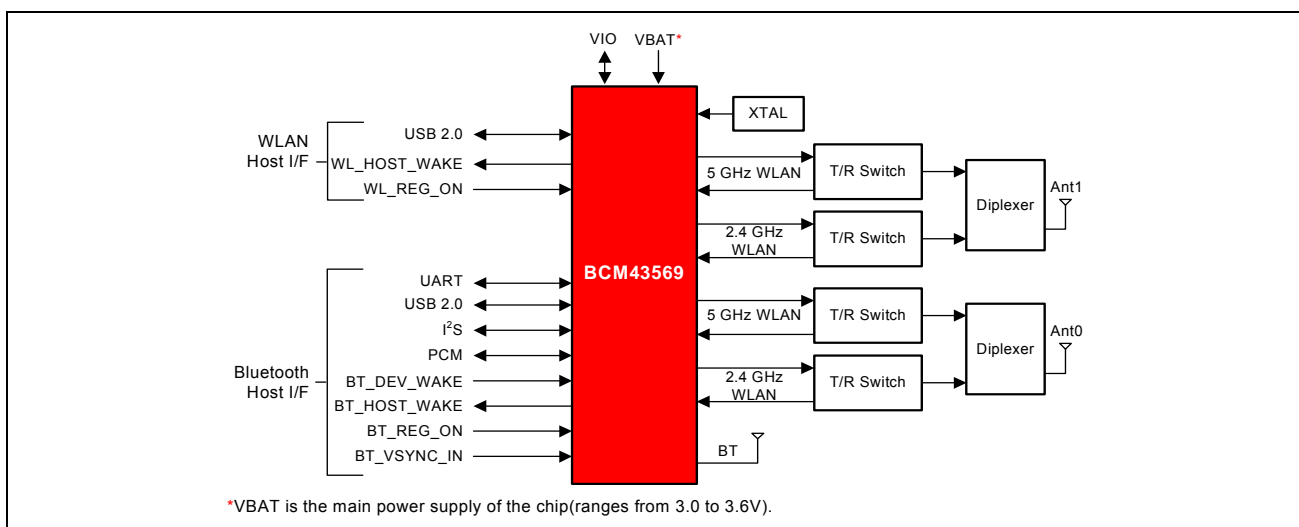

FEATURES**IEEE 802.11X Key Features (cont.)**

- Integrated ARMCR4 processor with tightly coupled memory for complete WLAN subsystem functionality, minimizing the need to wake up the applications processor for standard WLAN functions. This allows for further minimization of power consumption, while maintaining the ability to field upgrade with future features. On-chip memory includes 768 KB SRAM and 640 KB ROM.
- OneDriver™ software architecture for easy migration from existing embedded WLAN and Bluetooth devices as well as future devices.

Bluetooth Key Features

- Complies with Bluetooth Core Specification Version 4.1 + EDR with provisions for supporting future specifications.
- Bluetooth class 1 or class 2 transmitter operation.
- Supports extended synchronous connections (eSCO) for enhanced voice quality by allowing for retransmission of dropped packets.
- Adaptive frequency hopping (AFH) for reducing radio frequency interference.
- Interface support: host controller interface (HCI) using a USB or high-speed UART interface and PCM for audio data.
- Supports USB 2.0 full-speed (12 Mbps).

FEATURES**Bluetooth Key Features (cont.)**

- Low power mode improves power consumption of media devices
- Supports multiple simultaneous Advanced Audio Distribution Profiles (A2DP) for stereo sound.
- Automatic frequency detection for standard crystal and TCXO values.
- Supports serial flash interfaces.

General Features

- Supports device voltages from 3.0V to 3.6V by using an internal switching regulator.
- Programmable dynamic power management.
- 484 bytes of user-accessible OTP memory for storing board parameters.
- Supports 16 GPIOs.
- Package: 254-ball FCBGA (10 mm × 10 mm, 0.4 mm pitch)
- Security:
 - WPA and WPA2 (Personal) support for powerful encryption and authentication.
 - AES and TKIP in hardware for faster data encryption and IEEE 802.11i compatibility.
 - Reference WLAN subsystem provides Cisco Compatible Extensions (CCX, CCX 2.0, CCX 3.0, CCX 4.0, CCX 5.0).
 - Reference WLAN subsystem provides Wi-Fi Protected Setup (WPS).
- Worldwide regulatory support: Global products supported with worldwide homologated design.

Revision History

<i>Revision</i>	<i>Date</i>	<i>Change Description</i>
43569-DS109-R	01/19/16	Updated: <ul style="list-style-type: none">• Cover page, General Description• “IEEE 802.11ac Draft MAC” on page 57• Table 17: “Pin List,” on page 66• Table 18: “Signal Descriptions,” on page 70
43569-DS108-R	07/23/15	Updated: <ul style="list-style-type: none">• External Coexistence Interface (deleted)• Table 41: “Typical WLAN Power Consumption,” on page 108• SPI references deleted throughout the document

Broadcom Corporation
5300 California Avenue
Irvine, CA 92617

© 2016 by Broadcom Corporation
All rights reserved
Printed in the U.S.A.

Broadcom[®], the pulse logo, Connecting everything[®], the Connecting everything logo, OneDriver[™], and SmartAudio[®] are among the trademarks of Broadcom Corporation and/or its affiliates in the United States, certain other countries and/or the EU. Any other trademarks or trade names mentioned are the property of their respective owners.

This data sheet (including, without limitation, the Broadcom component(s) identified herein) is not designed, intended, or certified for use in any military, nuclear, medical, mass transportation, aviation, navigations, pollution control, hazardous substances management, or other high-risk application. BROADCOM PROVIDES THIS DATA SHEET “AS-IS,” WITHOUT WARRANTY OF ANY KIND. BROADCOM DISCLAIMS ALL WARRANTIES, EXPRESSED AND IMPLIED, INCLUDING, WITHOUT LIMITATION, THE IMPLIED WARRANTIES OF MERCHANTABILITY, FITNESS FOR A PARTICULAR PURPOSE, AND NON-INFRINGEMENT.

Revision	Date	Change Description
43569-DS107-R	05/13/15	<p>Updated:</p> <ul style="list-style-type: none"> • Features and General Description on page 1 and 2. • Table 1: “Device Interface Support,” on page 13. • Figure 2: “BCM43569 Block Diagram,” on page 14. • “Power Supply Topology” on page 17. • “Power Amplifier” and “Receiver” on page 27. • “Features” on page 46. • “IEEE 802.11ac Draft PHY” on page 63. • Figure 27: “FCBGA Ball Map, 10 mm × 10 mm Array, 254 Balls, A12–AC23 (Top View, Balls Facing Down),” on page 67. • Table 18: “Pin List,” on page 68. • Table 19: “Signal Descriptions,” on page 72. • Table 22: “GPIO_[10, 9, 8] Host Interface Selection,” on page 79. • Table 28: “Bluetooth Receiver RF Specifications,” on page 88. • Table 33: “WLAN 2.4 GHz Receiver Performance Specifications,” on page 92. • Table 35: “WLAN 2.4 GHz Transmitter Performance Specifications,” on page 100. • Table 36: “WLAN 5 GHz Receiver Performance Specifications,” on page 101. • Table 37: “WLAN 5 GHz Transmitter Performance Specifications,” on page 106. • “Description of Control Signals” on page 116. • Figure 30: “WLAN = ON, Bluetooth = ON,” on page 117. • Figure 32: “WLAN = ON, Bluetooth = OFF,” on page 118. • Figure 33: “WLAN = OFF, Bluetooth = ON,” on page 118. <p>Added:</p> <ul style="list-style-type: none"> • “WLAN USB 2.0 Interface” on page 56. • Figure 35: “Bluetooth Boot-Up Sequence,” on page 120. <p>Removed:</p> <ul style="list-style-type: none"> • HSIC Interface information.
43569-DS106-R	10/7/14	<p>Updated:</p> <ul style="list-style-type: none"> • Figure 36: “254-Ball Package Mechanical Information,” on page 123.
43569-DS105-R	08/29/14	For earlier revision history, refer to the released document.

Table of Contents

About This Document	12
Purpose and Audience	12
Acronyms and Abbreviations	12
References	12
Technical Support	12
Section 1: Overview	14
Overview	14
Features	16
Standards Compliance	17
Section 2: Power Supplies and Power Management	18
Power Supply Topology	18
BCM43569 PMU Features	18
WLAN Power Management	20
PMU Sequencing	21
Power-Off Shutdown	22
Power-Up/Power-Down/Reset Circuits	22
Section 3: Frequency References	23
Crystal Interface and Clock Generation	23
External Frequency Reference	24
Section 4: Bluetooth Overview	26
Features	26
Bluetooth Radio	27
Transmit	27
Digital Modulator	27
Digital Demodulator and Bit Synchronizer	27
Power Amplifier	28
Receiver	28
Digital Demodulator and Bit Synchronizer	28
Receiver Signal Strength Indicator	28
Local Oscillator Generation	28
Calibration	28
Section 5: Bluetooth Baseband Core	29
Bluetooth 4.1 Features	29
Bluetooth Low Energy	29
Link Control Layer	30
Test Mode Support	30

Bluetooth Power Management Unit 31

- RF Power Management 31
- Host Controller Power Management 31
- BBC Power Management..... 33
- Wideband Speech 33
- Packet Loss Concealment..... 34
- Audio Rate-Matching Algorithms..... 34
- Codec Encoding 35
- Multiple Simultaneous A2DP Audio Stream 35
- Burst Buffer Operation..... 35

Adaptive Frequency Hopping..... 35

Advanced Bluetooth/WLAN Coexistence..... 36

Fast Connection (Interlaced Page and Inquiry Scans) 36

Section 6: Microprocessor and Memory Unit for Bluetooth..... **37**

- RAM, ROM, and Patch Memory** 37
- Reset**..... 37

Section 7: BT Peripheral Transport Unit **38**

- UART Transport Detection** 38
- PCM Interface**..... 38
 - Slot Mapping 38
 - Frame Synchronization 39
 - Data Formatting..... 39
 - Wideband Speech Support 39
 - Burst PCM Mode 39
 - PCM Interface Timing..... 40
 - Short Frame Sync, Master Mode 40
 - Short Frame Sync, Slave Mode 41
 - Long Frame Sync, Master Mode..... 42
 - Long Frame Sync, Slave Mode..... 43
 - Short Frame Sync, Burst Mode..... 44
 - Long Frame Sync, Burst Mode 45
- Bluetooth USB Interface** 46
 - Features 46
 - Operation..... 46
 - USB Full-Speed Timing..... 48
- UART Interface**..... 49
- I²S Interface**..... 51
 - I²S Timing..... 52

Section 8: WLAN Global Functions 54

- WLAN CPU and Memory Subsystem 54
- One-Time Programmable Memory 54
- GPIO Interface 54
- WLAN USB 2.0 Interface 55
- UART Interface 56
- JTAG Interface 56
- SPROM Interface 57
- SFLASH Interface 57

Section 9: Wireless LAN MAC and PHY 58

- IEEE 802.11ac Draft MAC 58
 - PSM 59
 - WEP 59
 - TXE 60
 - RXE 60
 - IFS 60
 - TSF 61
 - NAV 61
 - MAC-PHY Interface 61
- IEEE 802.11ac Draft PHY 62

Section 10: WLAN Radio Subsystem 64

- Receiver Path 64
- Transmitter Path 64
- Calibration 64

Section 11: Ball Map and Signal Descriptions 65

- Ball Map 65
- Pin List 67
- Signal Descriptions 71
- WLAN/BT GPIO Signals and Strapping Options 78
- GPIO Alternative Signal Functions 79
- I/O States 80

Section 12: DC Characteristics 83

- Absolute Maximum Ratings 83
- Environmental Ratings 84
- Recommended Operating Conditions and DC Characteristics 85

Section 13: Bluetooth RF Specifications	86
Section 14: WLAN RF Specifications	90
Introduction.....	90
2.4 GHz Band General RF Specifications.....	90
WLAN 2.4 GHz Receiver Performance Specifications	91
WLAN 2.4 GHz Transmitter Performance Specifications	96
WLAN 5 GHz Receiver Performance Specifications	97
WLAN 5 GHz Transmitter Performance Specifications	102
Section 15: Internal Regulator Electrical Specifications	103
Core Buck Switching Regulator.....	103
2.5V LDO (BTLDO2P5)	104
CLDO	105
LNLDO	106
Section 16: System Power Consumption.....	107
WLAN Current Consumption.....	107
Bluetooth Current Consumption.....	110
Section 17: Interface Timing and AC Characteristics	111
JTAG Timing	111
Section 18: Power-Up Sequence and Timing	112
Sequencing of Reset and Regulator Control Signals	112
Description of Control Signals.....	112
Control Signal Timing Diagrams.....	113
Section 19: Package Information	117
Package Thermal Characteristics	117
Junction Temperature Estimation and PSI_{JT} Versus Θ_{JC}	117
Environmental Characteristics.....	117
Section 20: Mechanical Information	118
Section 21: Ordering Information	119

List of Figures

Figure 1: Functional Block Diagram.....	1
Figure 2: BCM43569 Block Diagram	15
Figure 3: Typical Power Topology for the BCM43569	19
Figure 4: Recommended Oscillator Configuration	23
Figure 5: Recommended Circuit to Use with an External Reference Clock.....	24
Figure 6: Startup Signaling Sequence	32
Figure 7: CVSD Decoder Output Waveform Without PLC.....	34
Figure 8: CVSD Decoder Output Waveform After Applying PLC.....	34
Figure 9: PCM Timing Diagram (Short Frame Sync, Master Mode).....	40
Figure 10: PCM Timing Diagram (Short Frame Sync, Slave Mode).....	41
Figure 11: PCM Timing Diagram (Long Frame Sync, Master Mode).....	42
Figure 12: PCM Timing Diagram (Long Frame Sync, Slave Mode).....	43
Figure 13: PCM Burst Mode Timing (Receive Only, Short Frame Sync).....	44
Figure 14: PCM Burst Mode Timing (Receive Only, Long Frame Sync)	45
Figure 15: USB Compounded Device Configuration	46
Figure 16: USB Full-Speed Timing	48
Figure 17: UART Timing	50
Figure 18: I ² S Transmitter Timing.....	53
Figure 19: I ² S Receiver Timing.....	53
Figure 20: WLAN USB 2.0 Host Interface Block Diagram	55
Figure 21: WLAN USB Timing	56
Figure 22: WLAN MAC Architecture	58
Figure 23: WLAN PHY Block Diagram.....	63
Figure 24: FCBGA Ball Map, 10 mm × 10 mm Array, 254 Balls, A1–AC12 (Top View, Balls Facing Down) ..	65
Figure 25: FCBGA Ball Map, 10 mm × 10 mm Array, 254 Balls, A12–AC23 (Top View, Balls Facing Down) 66	66
Figure 26: RF Port Location for Bluetooth Testing.....	86
Figure 27: Port Locations (Applies to 2.4 GHz and 5 GHz)	90
Figure 28: WLAN = ON, Bluetooth = ON	113
Figure 29: WLAN = OFF, Bluetooth = OFF.....	113
Figure 30: WLAN = ON, Bluetooth = OFF	114
Figure 31: WLAN = OFF, Bluetooth = ON	114
Figure 32: WLAN Boot-Up Sequence	115
Figure 33: Bluetooth Boot-Up Sequence	116
Figure 34: 254-Ball Package Mechanical Information	118

List of Tables

Table 1: Device Interface Support	14
Table 2: Power-Up/Power-Down/Reset Control Signals.....	22
Table 3: Crystal Oscillator and External Clock—Requirements and Performance	24
Table 4: Power Control Pin Description	31
Table 5: PCM-to-Serial Flash Interface Mapping.....	38
Table 6: PCM Interface Timing Specifications (Short Frame Sync, Master Mode).....	40
Table 7: PCM Interface Timing Specifications (Short Frame Sync, Slave Mode).....	41
Table 8: PCM Interface Timing Specifications (Long Frame Sync, Master Mode)	42
Table 9: PCM Interface Timing Specifications (Long Frame Sync, Slave Mode)	43
Table 10: PCM Burst Mode (Receive Only, Short Frame Sync).....	44
Table 11: PCM Burst Mode (Receive Only, Long Frame Sync)	45
Table 12: USB Full-Speed Timing Specifications	48
Table 13: Example of Common Baud Rates.....	49
Table 14: UART Timing Specifications	50
Table 15: Timing for I ² S Transmitters and Receivers	52
Table 16: USB2.0 Electrical Parameters	56
Table 17: Pin List.....	67
Table 18: Signal Descriptions	71
Table 19: WLAN GPIO Functions and Strapping Options	78
Table 20: BT GPIO Functions and Strapping Options	78
Table 21: GPIO_[10, 9, 8] Host Interface Selection.....	78
Table 22: GPIO Alternative Signal Functions	79
Table 23: I/O States	81
Table 24: Absolute Maximum Ratings	83
Table 25: Environmental Ratings	84
Table 26: Recommended Operating Conditions and DC Characteristics	85
Table 27: Bluetooth Receiver RF Specifications.....	87
Table 28: Bluetooth Transmitter RF Specifications.....	88
Table 29: Local Oscillator Performance.....	89
Table 30: BLE RF Specifications	89
Table 31: 2.4 GHz Band General RF Specifications.....	90
Table 32: WLAN 2.4 GHz Receiver Performance Specifications	91
Table 33: WLAN 2.4 GHz Transmitter Performance Specifications	96
Table 34: WLAN 5 GHz Receiver Performance Specifications	97
Table 35: WLAN 5 GHz Transmitter Performance Specifications	102

Table 36: Core Buck Switching Regulator (CBUCK) Specifications 103

Table 37: BTLDO2P5 Specifications 104

Table 38: CLDO Specifications 105

Table 39: LNLDO Specifications 106

Table 40: Typical WLAN Power Consumption 107

Table 41: Bluetooth Current Consumption 110

Table 42: JTAG Timing Characteristics 111

Table 43: Package Thermal Characteristics 117

About This Document

Purpose and Audience

This data sheet provides details on the functional, operational, and electrical characteristics for the Broadcom® BCM43569. It is intended for hardware design, application, and OEM engineers.

Acronyms and Abbreviations

In most cases, acronyms and abbreviations are defined on first use.

For a comprehensive list of acronyms and other terms used in Broadcom documents, go to:
<http://www.broadcom.com/press/glossary.php>.

References

The references in this section may be used in conjunction with this document.



Note: Broadcom provides customer access to technical documentation and software through its Customer Support Portal (CSP) and Downloads & Support site (see [Technical Support](#)).

For Broadcom documents, replace the “xx” in the document number with the largest number available in the repository to ensure that you have the most current version of the document.

<i>Document (or Item) Name</i>	<i>Number</i>	<i>Source</i>
[1] <i>Bluetooth MWS Coexistence 2-wire Transport Interface – Specification</i>	–	www.bluetooth.com
[2] <i>USB 2.0 Standard Specification</i>	–	www.usb.org

Technical Support

Broadcom provides customer access to a wide range of information, including technical documentation, schematic diagrams, product bill of materials, PCB layout information, and software updates through its customer support portal (<https://support.broadcom.com>). For a CSP account, contact your Sales or Engineering support representative.

In addition, Broadcom provides other product support through its Downloads & Support site (<http://www.broadcom.com/support/>).

Section 1: Overview

Overview

The Broadcom® BCM43569 single-chip device provides the highest level of integration for a mobile or handheld wireless system, with integrated IEEE 802.11 a/b/g/n/ac MAC/baseband/radio and Bluetooth 4.1 + EDR (enhanced data rate). It provides a small form-factor solution with minimal external components to drive down cost for mass volumes and allows for handheld device flexibility in size, form, and function. Comprehensive power management circuitry and software ensure the system can meet the needs of highly mobile devices that require minimal power consumption and reliable operation.

[Table 1](#) summarizes the device interface support.

Table 1: Device Interface Support

Feature	Interface Capable	Interface Support
USB 2.0 (Wi-Fi)	Yes	Yes
USB 2.0 (Bluetooth)	Yes	Yes
I ² S	Yes	No
GPIO	16	No
PCM	Yes	No
I ² S (Bluetooth)	Yes	No
GPIO (Wi-Fi)	Yes	Yes
BT GPIO (Bluetooth)	Yes	Yes
PCM (Bluetooth)	Yes	No
UART (Bluetooth)	Yes	No
UART (Wi-Fi)	Yes	No
JTAG (Wi-Fi)	Yes	No

[Figure 2 on page 15](#) shows the interconnect of all the major physical blocks in the BCM43569 and their associated external interfaces, which are described in greater detail in the following sections.

Figure 2: BCM43569 Block Diagram

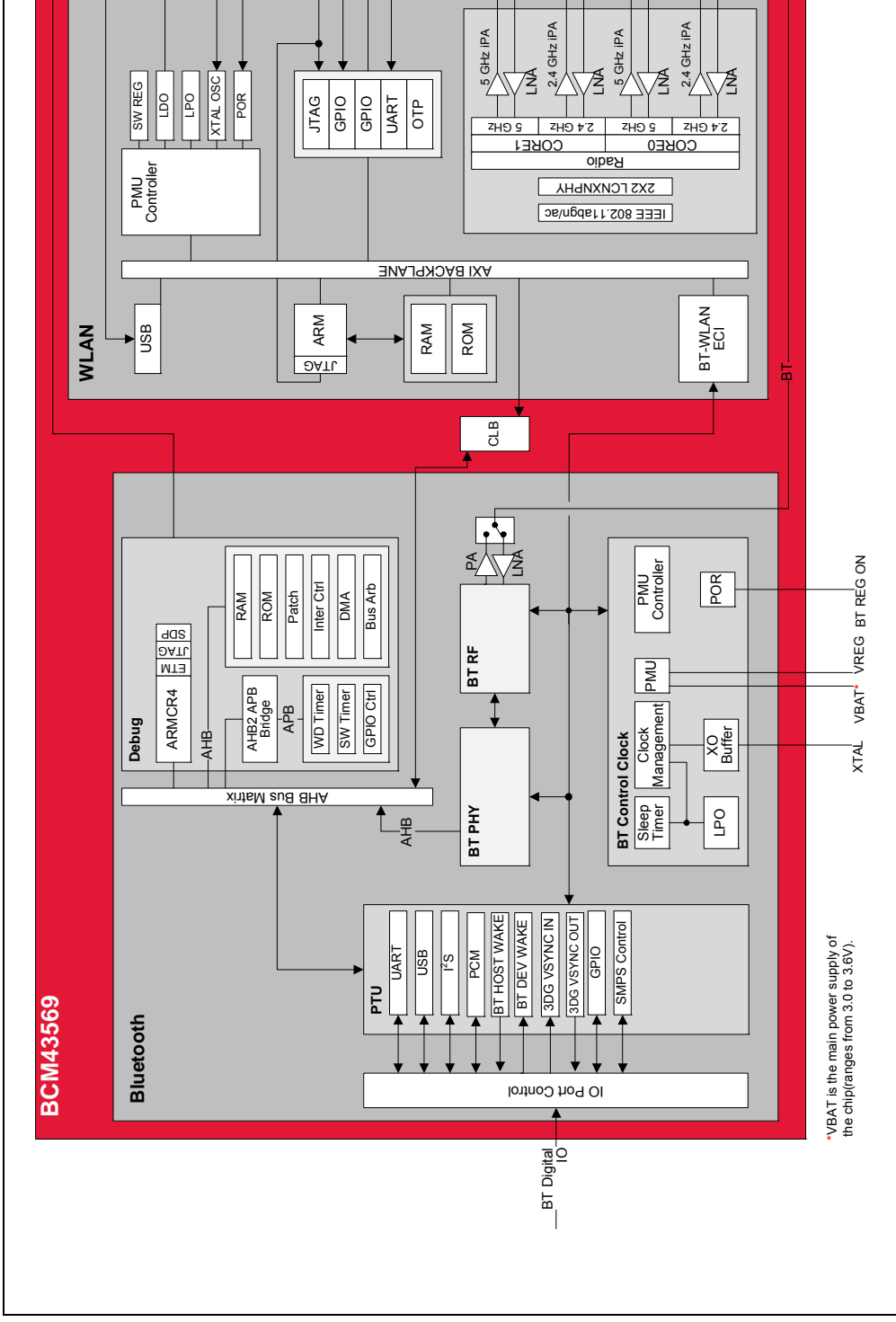

Features

The BCM43569 supports the following features:

- An IEEE 802.11a/b/g/n/ac dual-band 2 × 2 MIMO radio with virtual-simultaneous dual-band operation.
- Bluetooth 4.1 + EDR with an integrated class 1 PA.
- Concurrent Bluetooth and WLAN operation.
- On-chip WLAN driver execution capable of supporting IEEE 802.11 functionality.
- WLAN host interface option: USB 2.0.
- BT host digital interface (can be used concurrently with the above interface): UART (up to 4 Mbps).
- A full-speed USB 2.0-compliant interface for Bluetooth.
- ECI—enhanced coexistence support for coordinating BT SCO transmissions around WLAN receptions.
- Host controller interface (HCI) high-speed UART (H4, H4+, H5) transport support.
- Wideband speech (WBS) support (16-bit linear data, MSB first, left-justified at 4K samples/s for transparent AIR coding, both through I²S and PCM interface)
- Bluetooth SmartAudio[®] technology improves voice and music quality to headsets.
- Bluetooth low-power inquiry and page scan.
- Bluetooth low energy (BLE) support.
- Bluetooth packet loss concealment (PLC).
- Bluetooth wideband speech.

Standards Compliance

The BCM43569 supports the following standards:

- Bluetooth 2.1 + EDR
- Bluetooth 3.0 + HS
- Bluetooth 4.1 (Bluetooth low energy)
- IEEE802.11ac mandatory and optional requirements for 20 MHz, 40 MHz, and 80 MHz channels
- IEEE 802.11n (Handheld Device Class, Section 11)
- IEEE 802.11a
- IEEE 802.11b
- IEEE 802.11g
- IEEE 802.11d
- IEEE 802.11h
- IEEE 802.11i
- Security:
 - WEP
 - WPA Personal
 - WPA2 Personal
 - WMM
 - WMM-PS (U-APSD)
 - WMM-SA
 - AES (hardware accelerator)
 - TKIP (hardware accelerator)
 - CKIP (software support)
- Proprietary protocols:
 - CCXv2
 - CCXv3
 - CCXv4
 - CCXv5
- IEEE 802.15.2 (coexistence compliance on-silicon solution compliant with IEEE three-wire requirements)

The BCM43569 will support the following future drafts/standards:

- IEEE 802.11r (fast roaming between APs)
- IEEE 802.11w (secure management frames)
- IEEE 802.11 extensions:
 - IEEE 802.11e QoS enhancements (In accordance with the WMM specification, QoS is already supported.)
 - IEEE 802.11h 5 GHz extensions
 - IEEE 802.11i MAC enhancements
 - IEEE 802.11k radio resource measurement

Section 2: Power Supplies and Power Management

Power Supply Topology

One buck regulator, multiple LDO regulators, and a power management unit (PMU) are integrated into the BCM43569. All regulators are programmable via the PMU. These blocks simplify power supply design for Bluetooth and WLAN functions in embedded designs.

A single VBAT (3.0V to 3.6V maximum) and VIO supply (1.8V to 3.6V) can be used, with all additional voltages being provided by the regulators in the BCM43569.

Two control signals, BT_REG_ON and WL_REG_ON, are used to power-up the regulators and take the respective section out of reset. The Core-Buck (CLOCK), CLDO, and LNLDO power up when any of the reset signals are deasserted. All regulators are powered down only when both BT_REG_ON and WL_REG_ON are deasserted. The CLDO and LNLDO may be turned off/on based on the dynamic demands of the digital baseband.

The BCM43569 allows for an extremely low power-consumption mode by completely shutting down the CBUCK, CLDO, and LNLDO regulators. When in this state, LPLDO1 (which is a low-power linear regulators that is supplied by the system VIO supply), provides the BCM43569 with all the voltages it requires, further reducing leakage currents.

BCM43569 PMU Features

- VBAT to 1.35Vout (550 mA nominal, 870 mA maximum) CBUCK switching regulator
- VBAT to 2.5V out (15 mA nominal, 70 mA maximum) BTLDO2P5
- 1.35V to 1.2Vout (100 mA nominal, 150 mA maximum) LNLDO
- 1.35V to 1.2Vout (350 mA nominal, 500 mA maximum) CLDO with bypass mode for deep-sleep
- Additional internal LDOs (not externally accessible)



Note: VBAT is the main power supply of the chip (ranges from 3.0 to 3.6V).

WLAN Power Management

The BCM43569 has been designed with the stringent power consumption requirements of DTV, OTT, and STB mobile devices in mind. All areas of the chip design are optimized to minimize power consumption. Silicon processes and cell libraries were chosen to reduce leakage current and supply voltages. Additionally, the BCM43569 integrated RAM is a high Vt memory with dynamic clock control. The dominant supply current consumed by the RAM is leakage current only. Additionally, the BCM43569 includes an advanced WLAN power management unit sequencer. The PMU sequencer provides significant power savings by putting the BCM43569 into various power management states appropriate to the current environment and activities that are being performed. The power management unit enables and disables internal regulators, switches, and other blocks based on a computation of the required resources and a table that describes the relationship between resources and the time needed to enable and disable them. Power up sequences are fully programmable. Configurable, free-running counters (running at 32.768 kHz LPO clock) in the PMU sequencer are used to turn on/turn off individual regulators and power switches. Clock speeds are dynamically changed (or gated altogether) for the current mode. Slower clock speeds are used wherever possible.

The BCM43569 WLAN power states are described as follows:

- **Active mode:** All WLAN blocks in the BCM43569 are powered up and fully functional with active carrier sensing and frame transmission and receiving. All required regulators are enabled and put in the most efficient mode based on the load current. Clock speeds are dynamically adjusted by the PMU sequencer.
- **Doze mode:** The radio, analog domains, and most of the linear regulators are powered down. The rest of the BCM43569 remains powered up in an IDLE state. All main clocks (PLL, crystal oscillator, or TCXO) are shut down to reduce active power to the minimum. The 32.768 kHz LPO clock is available only for the PMU sequencer. This condition is necessary to allow the PMU sequencer to wake up the chip and transition to Active mode. In Doze mode, the primary power consumed is due to leakage current.
- **Deep-sleep mode:** Most of the chip including both analog and digital domains and most of the regulators are powered off. Logic states in the digital core are saved and preserved into a retention memory in the always-ON domain before the digital core is powered off. Upon a wake-up event triggered by the PMU timers, an external interrupt or a host resume through the USB 2.0 bus, logic states in the digital core are restored to their pre-deep-sleep settings to avoid lengthy HW reinitialization.
- **Power-down mode:** The BCM43569 is effectively powered off by shutting down all internal regulators. The chip is brought out of this mode by external logic re-enabling the internal regulators.

PMU Sequencing

The PMU sequencer is responsible for minimizing system power consumption. It enables and disables various system resources based on a computation of the required resources and a table that describes the relationship between resources and the time needed to enable and disable them.

Resource requests may come from several sources: clock requests from cores, the minimum resources defined in the ResourceMin register, and the resources requested by any active resource request timers. The PMU sequencer maps clock requests into a set of resources required to produce the requested clocks.

Each resource is in one of four states: enabled, disabled, transition_on, and transition_off and has a timer that contains 0 when the resource is enabled or disabled and a non-zero value in the transition states. The timer is loaded with the time_on or time_off value of the resource when the PMU determines that the resource must be enabled or disabled. That timer decrements on each 32.768 kHz PMU clock. When it reaches 0, the state changes from transition_off to disabled or transition_on to enabled. If the time_on value is 0, the resource can go immediately from disabled to enabled. Similarly, a time_off value of 0 indicates that the resource can go immediately from enabled to disabled. The terms enable sequence and disable sequence refer to either the immediate transition or the timer load-decrement sequence.

During each clock cycle, the PMU sequencer performs the following actions:

- Computes the required resource set based on requests and the resource dependency table.
- Decrements all timers whose values are non zero. If a timer reaches 0, the PMU clears the ResourcePending bit for the resource and inverts the ResourceState bit.
- Compares the request with the current resource status and determines which resources must be enabled or disabled.
- Initiates a disable sequence for each resource that is enabled, no longer being requested, and has no powered up dependents.
- Initiates an enable sequence for each resource that is disabled, is being requested, and has all of its dependencies enabled.

Power-Off Shutdown

The BCM43569 provides a low-power shutdown feature that allows the device to be turned off while the host, and any other devices in the system, remain operational. When the BCM43569 is not needed in the system, VDDIO_RF and VDDC are shut down while VDDIO remains powered. This allows the BCM43569 to be effectively off, while keeping the I/O pins powered so that they do not draw extra current from any other devices connected to the I/O.

During a low-power shut-down state, provided VDDIO remains applied to the BCM43569, all outputs are tristated, and most inputs signals are disabled. Input voltages must remain within the limits defined for normal operation. This is done to prevent current paths or create loading on any digital signals in the system, and enables the BCM43569 to be fully integrated in an embedded device and take full advantage of the lowest power-savings modes.

When the BCM43569 is powered on from this state, it is the same as a normal power-up and the device does not retain any information about its state from before it was powered down.

Power-Up/Power-Down/Reset Circuits

The BCM43569 has two signals (see [Table 2](#)) that enable or disable the Bluetooth and WLAN circuits and the internal regulator blocks, allowing the host to control power consumption. For timing diagrams of these signals and the required power-up sequences, see [Section 18: “Power-Up Sequence and Timing,”](#) on page 112.

Table 2: Power-Up/Power-Down/Reset Control Signals

Signal	Description
WL_REG_ON	This signal is used by the PMU (with BT_REG_ON) to power up the WLAN section. It is also OR-gated with the BT_REG_ON input to control the internal BCM43569 regulators. When this pin is high, the regulators are enabled and the WLAN section is out of reset. When this pin is low, the WLAN section is in reset. If BT_REG_ON and WL_REG_ON are both low, the regulators are disabled. This pin has an internal 200 kΩ pull-down resistor that is enabled by default. It can be disabled through programming.
BT_REG_ON	This signal is used by the PMU (with WL_REG_ON) to decide whether or not to power down the internal BCM43569 regulators. If BT_REG_ON and WL_REG_ON are low, the regulators will be disabled. This pin has an internal 200 kΩ pull-down resistor that is enabled by default. It can be disabled through programming.

Section 3: Frequency References

An external crystal is used for generating all radio frequencies and normal operation clocking. As an alternative, an external frequency reference may be used. In addition, a low-power oscillator (LPO) is provided for lower power mode timing.

Crystal Interface and Clock Generation

The BCM43569 can use an external crystal to provide a frequency reference. The recommended configuration for the crystal oscillator including all external components is shown in [Figure 4](#). Consult the reference schematics for the latest configuration.

Figure 4: Recommended Oscillator Configuration

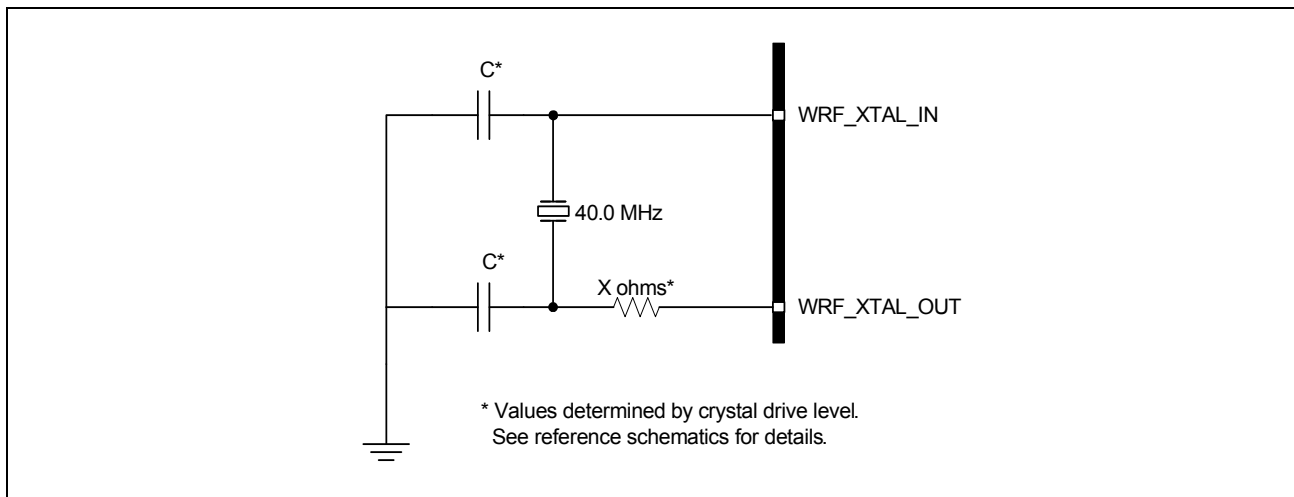

A fractional-N synthesizer in the BCM43569 generates the radio frequencies, clocks, and data/packet timing, enabling it to operate using a wide selection of frequency references.

The recommended default frequency reference is a 40.0 MHz crystal. For USB applications, see [Table 3 on page 24](#) for details. The signal characteristics for the crystal interface are listed in [Table 3 on page 24](#).



Note: Although the fractional-N synthesizer can support alternative reference frequencies, frequencies other than the default require support to be added in the driver, plus additional extensive system testing. Contact Broadcom for further details.

External Frequency Reference

As an alternative to a crystal, an external precision frequency reference can be used. The recommended default frequency is 52 MHz \pm 10 ppm, and it must meet the phase noise requirements listed in [Table 3](#).

If used, the external clock should be connected to the WRF_XTAL_IN pin through an external 1000 pF coupling capacitor, as shown in [Figure 5](#). The internal clock buffer connected to this pin will be turned off when the BCM43569 goes into sleep mode. When the clock buffer turns on and off there will be a small impedance variation. Power must be supplied to the WRF_XTAL_VDD1P5 pin.

Figure 5: Recommended Circuit to Use with an External Reference Clock

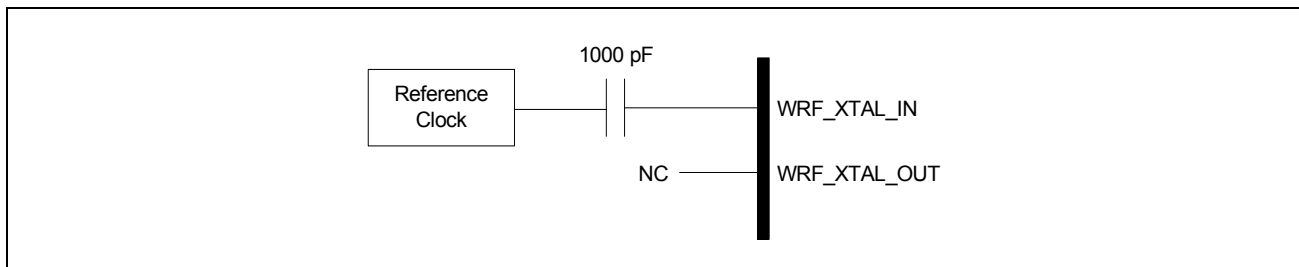

Table 3: Crystal Oscillator and External Clock—Requirements and Performance

Parameter	Conditions/Notes	Crystal ^a			External Frequency Reference ^{b c}			Units
		Min.	Typ.	Max.	Min.	Typ.	Max.	
Frequency	2.4G and 5G bands: IEEE 802.11ac operation	–	40	–	–	–	–	MHz
Frequency tolerance over the lifetime of the equipment, including temperature ^d	Without trimming	–20	–	20	–20	–	20	ppm
Crystal load capacitance	–	–	12	–	–	–	–	pF
ESR	–	–	–	60	–	–	–	Ω
Drive level	External crystal must be able to tolerate this drive level.	200	–	–	–	–	–	μ W
Input impedance (WRF_XTAL_IN)	Resistive	–	–	–	30	100	–	k Ω
	Capacitive	–	–	7.5	–	–	7.5	pF
WRF_XTAL_IN Input low level	DC-coupled digital signal	–	–	–	0	–	0.2	V
WRF_XTAL_IN Input high level	DC-coupled digital signal	–	–	–	1.0	–	1.26	V
WRF_XTAL_IN input voltage (see Figure 5)	AC-coupled analog signal	–	–	–	400	–	1200	mV _{p-p}
Duty cycle	40 MHz clock	–	–	–	40	50	60	%

Table 3: Crystal Oscillator and External Clock—Requirements and Performance (Cont.)

Parameter	Conditions/Notes	Crystal ^a			External Frequency Reference ^{b c}			Units
		Min.	Typ.	Max.	Min.	Typ.	Max.	
Phase noise ^e (IEEE 802.11b/g)	40 MHz clock at 10 kHz offset	-	-	-	-	-	-129	dBc/Hz
	40 MHz clock at 100 kHz offset	-	-	-	-	-	-136	dBc/Hz
Phase noise ^e (IEEE 802.11a)	40 MHz clock at 10 kHz offset	-	-	-	-	-	-137	dBc/Hz
	40 MHz clock at 100 kHz offset	-	-	-	-	-	-144	dBc/Hz
Phase noise ^e (IEEE 802.11n, 2.4 GHz)	40 MHz clock at 10 kHz offset	-	-	-	-	-	-134	dBc/Hz
	40 MHz clock at 100 kHz offset	-	-	-	-	-	-141	dBc/Hz
Phase noise ^e (IEEE 802.11n, 5 GHz)	40 MHz clock at 10 kHz offset	-	-	-	-	-	-142	dBc/Hz
	40 MHz clock at 100 kHz offset	-	-	-	-	-	-149	dBc/Hz
Phase noise ^e (IEEE 802.11ac, 5 GHz)	40 MHz clock at 10 kHz offset	-	-	-	-	-	-150	dBc/Hz
	40 MHz clock at 100 kHz offset	-	-	-	-	-	-157	dBc/Hz

- a. (Crystal) Use WRF_XTAL_IN and WRF_XTAL_OUT.
- b. See “External Frequency Reference” on page 24 for alternative connection methods.
- c. For a clock reference other than 40 MHz, $20 \times \log_{10}(f/40)$ dB should be added to the limits, where f = the reference clock frequency in MHz.
- d. It is the responsibility of the equipment designer to select oscillator components that comply with these specifications.
- e. Assumes that the external clock has a flat phase noise response above 100 kHz.

Section 4: Bluetooth Overview

The BCM43569 is a Bluetooth 4.1 + EDR-compliant, baseband processor/2.4 GHz transceiver. It features the highest level of integration and eliminates all critical external components, thus minimizing the footprint, power consumption, and system cost of a Bluetooth radio solution.

The BCM43569 is the optimal solution for any Bluetooth voice and/or data application. The Bluetooth subsystem presents a standard host controller interface (HCI) via a high-speed UART and PCM for audio. The BCM43569 incorporates all Bluetooth 4.1 features including secure simple pairing, sniff subrating, and encryption pause and resume.

The BCM43569 Bluetooth radio transceiver provides enhanced radio performance. It is fully compatible with any of the standard TCXO frequencies and provides full radio compatibility to operate simultaneously with GPS, WLAN, and cellular radios.

The Bluetooth transmitter also features a class 1 power amplifier with class 2 capability.

Features

Major Bluetooth features of the BCM43569 include:

- Supports key features of upcoming Bluetooth standards
- Fully supports Bluetooth Core Specification version 4.1 + EDR features:
 - Adaptive frequency hopping (AFH)
 - Quality of service (QoS)
 - Extended synchronous connections (eSCO)—voice connections
 - Fast connect (interlaced page and inquiry scans)
 - Secure simple pairing (SSP)
 - Sniff subrating (SSR)
 - Encryption pause resume (EPR)
 - Extended inquiry response (EIR)
 - Link supervision timeout (LST)
- UART baud rates up to 4 Mbps
- Supports all Bluetooth 4.1 + EDR packet types
- Supports maximum Bluetooth data rates over HCI UART (interface capable but not currently supported in software driver.)
- BT supports full-speed USB 2.0-compliant interface
- Multipoint operation with up to seven active slaves
 - Maximum of seven simultaneous active ACL links
 - Maximum of three simultaneous active SCO and eSCO connections with scatternet support
- Trigger Broadcom fast connect (TBFC)

- Narrowband and wideband packet loss concealment
- Scatternet operation with up to four active piconets with background scan and support for scatter mode
- High-speed HCI UART transport support with low-power out-of-band BT_DEV_WAKE and BT_HOST_WAKE signaling (see [“Host Controller Power Management” on page 31](#))
- Channel quality driven data rate and packet type selection
- Standard Bluetooth test modes
- Extended radio and production test mode features
- Full support for power savings modes
 - Bluetooth clock request
 - Bluetooth standard sniff
 - Deep-sleep modes and software regulator shutdown
- TCXO input and auto-detection of all standard handset clock frequencies. Also supports a low-power crystal that can be used during power save mode for better timing accuracy.

Bluetooth Radio

The BCM43569 has an integrated radio transceiver that has been optimized for use in 2.4 GHz Bluetooth wireless systems. It has been designed to provide low-power, low-cost, and robust communications for applications operating in the globally available 2.4 GHz unlicensed ISM band. It is fully compliant with the Bluetooth Radio Specification and EDR specification and meets or exceeds the requirements to provide the highest communication link quality of service. An integrated T/R switch combines the Bluetooth transmit and receive paths, and connects directly to a dedicated Bluetooth antenna.

Transmit

The BCM43569 features a fully integrated zero-IF transmitter. The baseband transmit data is GFSK-modulated in the modem block and upconverted to the 2.4 GHz ISM band in the transmitter path. The transmitter path contains signal filtering, I/Q upconversion, an output power amplifier, and RF filtering. The transmitter path also incorporates $\pi/4$ -DQPSK for 2 Mbps and 8-DPSK for 3 Mbps to support EDR. The transmitter section is compatible with the Bluetooth low-energy specification. The transmitter PA bias can also be adjusted to provide Bluetooth class 1 or class 2 operation.

Digital Modulator

The digital modulator performs the data modulation and filtering required for the GFSK, $\pi/4$ -DQPSK, and 8-DPSK signal. The fully digital modulator minimizes any frequency drift or anomalies in the modulation characteristics of the transmitted signal and is much more stable than direct VCO modulation schemes.

Digital Demodulator and Bit Synchronizer

The digital demodulator and bit synchronizer take the low-IF received signal and perform an optimal frequency tracking and bit-synchronization algorithm.

Power Amplifier

The fully integrated PA supports class 1 or class 2 output using a highly linearized, temperature-compensated design. This provides greater flexibility in front-end matching and filtering. Due to the linear nature of the PA combined with some integrated filtering, external filtering is required to meet the Bluetooth and regulatory harmonic and spurious requirements. The transmitter features a sophisticated on-chip transmit signal strength indicator (TSSI) block to keep the absolute output power variation within a tight range across process, voltage, and temperature.

Receiver

The receiver path uses a low-IF scheme to downconvert the received signal for demodulation in the digital demodulator and bit synchronizer. The receiver path provides a high degree of linearity, an extended dynamic range, and high-order on-chip channel filtering to ensure reliable operation in the noisy 2.4 GHz ISM band. The front-end topology, with built-in out-of-band attenuation, enables the BCM43569 to be used in most applications with minimal off-chip filtering.

Digital Demodulator and Bit Synchronizer

The digital demodulator and bit synchronizer take the low-IF received signal and perform an optimal frequency tracking and bit synchronization algorithm.

Receiver Signal Strength Indicator

The radio portion of the BCM43569 provides a receiver signal strength indicator (RSSI) signal to the baseband controller so that the controller can take part in a Bluetooth power-controlled link, by providing a metric of its own receiver signal strength, to determine whether the transmitter should increase or decrease its output power.

Local Oscillator Generation

Local Oscillator (LO) generation provides fast frequency hopping (1600 hops/second) across the 79 maximum available channels. The LO generation subblock employs an architecture for high immunity to LO pulling during PA operation. The BCM43569 uses an internal RF and IF loop filter.

Calibration

The BCM43569 radio transceiver features an automated calibration scheme that is fully self contained in the radio. No user interaction is required during normal operation or during manufacturing to provide the optimal performance. Calibration optimizes the performance of all the major blocks within the radio to within 2% of optimal conditions, including gain and phase characteristics of filters, matching between key components, and key gain blocks. During normal operation, calibration takes place transparently during the settling times that follow frequency hops. Calibration data is used to compensate for process and temperature variations.

Section 5: Bluetooth Baseband Core

The Bluetooth baseband core (BBC) implements all of the time critical functions required for high-performance Bluetooth operation. The BBC manages the buffering, segmentation, and routing of data for all connections. It also buffers data that passes through it, handles data flow control, schedules SCO/ACL TX/RX transactions, monitors Bluetooth slot usage, optimally segments and packages data into baseband packets, manages connection status indicators, and composes and decodes HCI packets. In addition to these functions, it independently handles HCI event types and HCI command types.

The following transmit and receive functions are also implemented in the BBC hardware to increase the reliability and security of the TX/RX data before it is sent over the air:

- Symbol timing recovery, data deframing, forward error correction (FEC), header error control (HEC), cyclic redundancy check (CRC), data decryption, and data dewatering in the receiver.
- Data framing, FEC generation, HEC generation, CRC generation, key generation, data encryption, and data whitening in the transmitter.

Bluetooth 4.1 Features

The BBC supports all Bluetooth 4.1 features with the following benefits:

- Dual-mode Bluetooth low energy (BT and BLE operation)
- Extended inquiry response (EIR): Shortens the time to retrieve the device name, specific profile, and operating mode.
- Encryption pause resume (EPR): Enables the use of Bluetooth technology in a much more secure environment.
- Sniff subrating: Optimizes power consumption for low duty cycle asymmetric data flow, which subsequently extends battery life.
- Secure simple pairing: Reduces the number of steps for connecting two devices, with minimal or no user interaction required.
- Link supervision time out (LSTO): Additional commands added to the HCI and Link Management Protocol (LMP) for improved link time-out supervision.
- QoS enhancements: Changes to data traffic control, resulting in better link performance. Audio, human interface device (HID), bulk traffic, SCO, and enhanced SCO (eSCO) are improved with the erroneous data (ED) and packet boundary flag (PBF) enhancements.

Bluetooth Low Energy

The BCM43569 supports the Bluetooth low energy operating mode.

Link Control Layer

The link control layer is part of the Bluetooth link control functions that are implemented in dedicated logic in the link control unit (LCU). This layer consists of the command controller that takes commands from the software, and other controllers that are activated or configured by the command controller, to perform the link control tasks. Each task performs a different state in the Bluetooth link controller.

- Major states:
 - Standby
 - Connection
- Substates:
 - Page
 - Page scan
 - Inquiry
 - Inquiry scan
 - Sniff

Test Mode Support

The BCM43569 fully supports Bluetooth Test mode as described in Part I:1 of the *Specification of the Bluetooth System Version 3.0*. This includes the transmitter tests, normal and delayed loopback tests, and reduced hopping sequence.

In addition to the standard Bluetooth test mode, the BCM43569 also supports enhanced testing features to simplify RF debugging and qualification and type-approval testing. These features include:

- Fixed frequency carrier-wave (unmodulated) transmission
 - Simplifies some type-approval measurements (Japan)
 - Aids in transmitter performance analysis
- Fixed frequency constant receiver operation
 - Directs receiver output to an I/O pin
 - Allows for direct BER measurements using standard RF test equipment
 - Facilitates spurious emissions testing for receive mode
- Fixed frequency constant transmission operation
 - Provides an 8-bit fixed pattern or PRBS-9
 - Enables modulated signal measurements with standard RF test equipment

Bluetooth Power Management Unit

The Bluetooth power management unit (PMU) provides power management features that can be invoked by software-controlled power management registers or packet data in the baseband core. The power management functions provided by the BCM43569 are:

- [RF Power Management](#)
- [Host Controller Power Management](#)
- [BBC Power Management](#)

RF Power Management

The BBC generates power-down control signals for the transmit path, receive path, PLL, and power amplifier to the 2.4 GHz transceiver. The transceiver then processes the power-down functions accordingly.

Host Controller Power Management

When running in UART mode, the BCM43569 can be configured so that dedicated signals are used for power management handshaking between it and the host. The basic power-saving functions supported by those handshaking signals include the standard Bluetooth-defined power savings and standby modes.

[Table 4](#) describes the power-control handshake signals used with the UART interface.

Table 4: Power Control Pin Description

Signal	Mapped to Pin	Type	Description
BT_DEV_WAKE	J1	I	Bluetooth device wake up: Signal from the host to the BCM43569 indicating that the host requires attention. <ul style="list-style-type: none"> • Asserted: The Bluetooth device must wake up or remain awake. • Deasserted: The Bluetooth device may sleep when sleep criteria are met. The polarity of this signal is software configurable and can be asserted high or low.
BT_HOST_WAKE	J2	O	Host wake up. Signal from the BCM43569 to the host indicating that the BCM43569 requires attention. <ul style="list-style-type: none"> • Asserted: The host device must wake up or remain awake. • Deasserted: The host device may sleep when sleep criteria are met. The polarity of this signal is software configurable and can be asserted high or low.
BT_CLK_REQ	J5	O	The BCM43569 asserts BT_CLK_REQ when either the Bluetooth or WLAN functions want the host to turn on the reference clock. The BT_CLK_REQ polarity is active-high. Add an external 100 kΩ pull-down resistor to ensure that the signal is deasserted when the BCM43569 powers up or resets when VDDIO is present.

Note: Pad function Control Register is set to 0 for these pins (see [“DC Characteristics” on page 83](#)).

Figure 6: Startup Signaling Sequence

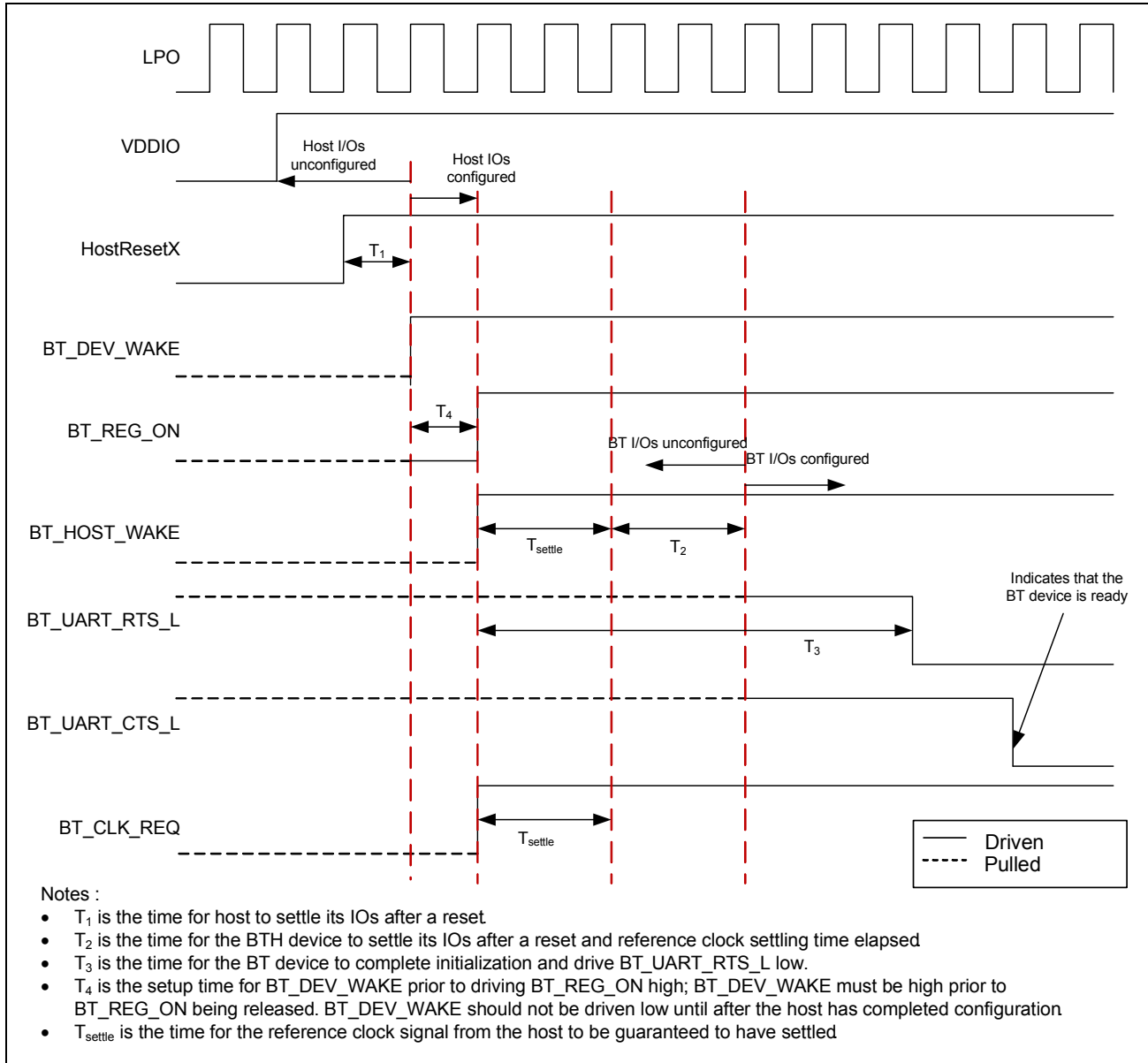

BBC Power Management

The following are low-power operations for the BBC:

- Physical layer packet-handling turns the RF on and off dynamically within transmit/receive packets.
- Bluetooth-specified low-power connection modes: sniff, hold, and park. While in these modes, the BCM43569 runs on the low-power oscillator and wakes up after a predefined time period.
- A low-power shutdown feature allows the device to be turned off while the host and any other devices in the system remain operational. When the BCM43569 is not needed in the system, the RF and core supplies are shut down while the I/O remains powered. This allows the BCM43569 to effectively be off while keeping the I/O pins powered so they do not draw extra current from any other devices connected to the I/O.

During the low-power shut-down state, provided VDDIO remains applied to the BCM43569, all outputs are tristated, and most input signals are disabled. Input voltages must remain within the limits defined for normal operation. This is done to prevent current paths or create loading on any digital signals in the system and enables the BCM43569 to be fully integrated in an embedded device to take full advantage of the lowest power-saving modes.

Two BCM43569 input signals are designed to be high-impedance inputs that do not load the driving signal even if the chip does not have VDDIO power supplied to it: the frequency reference input (WRF_TCXO_IN) and the 32.768 kHz input (LPO). When the BCM43569 is powered on from this state, it is the same as a normal power-up, and the device does not contain any information about its state from the time before it was powered down.

Wideband Speech

The BCM43569 provides support for wideband speech (WBS) using on-chip SmartAudio technology. The BCM43569 can perform subband-codec (SBC), as well as mSBC, encoding and decoding of linear 16 bits at 16 kHz (256 kbps rate) transferred over the PCM bus.

Packet Loss Concealment

The packet loss concealment (PLC) improves apparent audio quality for systems with marginal link performance. Bluetooth messages are sent in packets. When a packet is lost, it creates a gap in the received audio bit-stream. Packet loss can be mitigated in several ways:

- Fill in zeros.
- Ramp down the output audio signal toward zero (this is the method used in current Bluetooth headsets).
- Repeat the last frame (or packet) of the received bit-stream and decode it as usual (frame repeat).

These techniques cause distortion and popping in the audio stream. The BCM43569 uses a proprietary waveform extension algorithm to provide dramatic improvement in the audio quality. [Figure 7](#) and [Figure 8](#) show audio waveforms with and without Packet Loss Concealment. Broadcom PLC/BEC algorithms also support wideband speech.

Figure 7: CVSD Decoder Output Waveform Without PLC

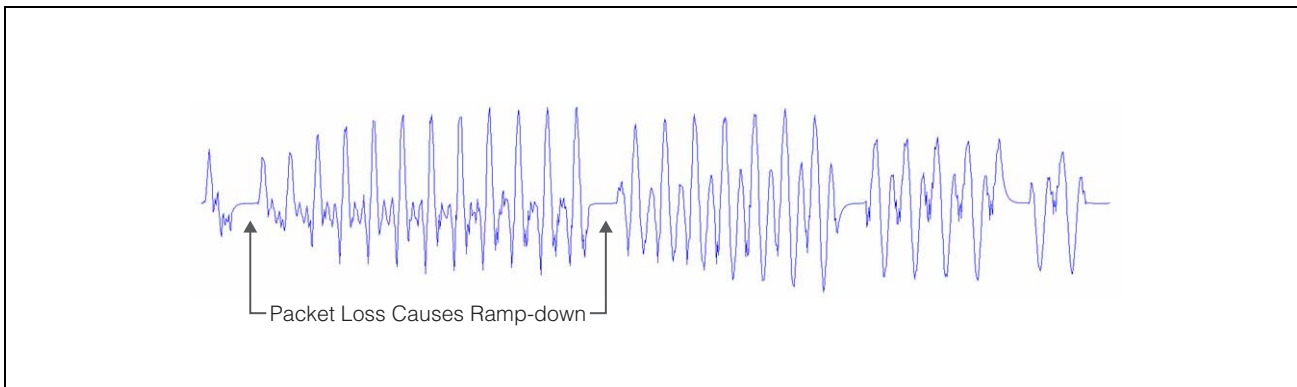
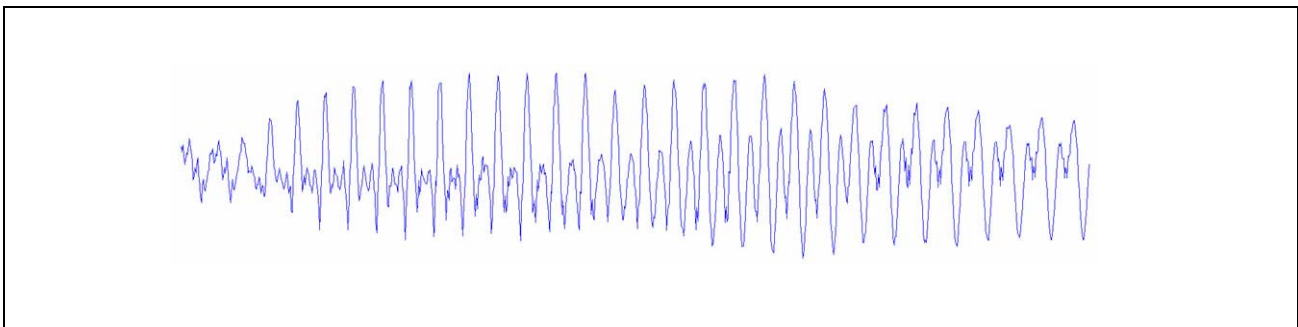

Figure 8: CVSD Decoder Output Waveform After Applying PLC



Audio Rate-Matching Algorithms

The BCM43569 has an enhanced rate-matching algorithm that uses interpolation algorithms to reduce audio stream jitter that may be present when the rate of audio data coming from the host is not the same as the Bluetooth audio data rates.

Codec Encoding

The BCM43569 can support SBC and mSBC encoding and decoding for wideband speech.

Multiple Simultaneous A2DP Audio Stream

The BCM43569 has the ability to take a single audio stream and output it to multiple Bluetooth devices simultaneously. This allows a user to share his or her music (or any audio stream) with a friend.

Burst Buffer Operation

The BCM43569 has a data buffer that can buffer data being sent over the HCI and audio transports, then send the data at an increased rate. This mode of operation allows the host to sleep for the maximum amount of time, dramatically reducing system current consumption.

Adaptive Frequency Hopping

The BCM43569 gathers link quality statistics on a channel by channel basis to facilitate channel assessment and channel map selection. The link quality is determined using both RF and baseband signal processing to provide a more accurate frequency-hop map.

Advanced Bluetooth/WLAN Coexistence

The BCM43569 includes advanced coexistence technologies that are only possible with a Bluetooth/WLAN integrated die solution. These coexistence technologies are targeted at small form-factor platforms, such as smart TVs, over-the-top (OTT) boxes, set-top boxes, and wireless speakers, including applications such as VoWLAN + SCO and video-over-WLAN + high fidelity BT stereo.

The BCM43569 integrated solution enables MAC-layer signaling (firmware) and a greater degree of sharing via an enhanced coexistence interface. Information is exchanged between the Bluetooth and WLAN cores without host processor involvement.

The BCM43569 also supports Transmit Power Control on the STA together with standard Bluetooth TPC to limit mutual interference and receiver desensitization. Preemption mechanisms are utilized to prevent AP transmissions from colliding with Bluetooth frames. Improved channel classification techniques have been implemented in Bluetooth for faster and more accurate detection and elimination of interferers (including non-WLAN 2.4 GHz interference).

The Bluetooth AFH classification is also enhanced by the WLAN core's channel information.

Fast Connection (Interlaced Page and Inquiry Scans)

The BCM43569 supports page scan and inquiry scan modes that significantly reduce the average inquiry response and connection times. These scanning modes are compatible with the Bluetooth version 2.1 page and inquiry procedures.

Section 6: Microprocessor and Memory Unit for Bluetooth

The Bluetooth microprocessor core is based on the ARM Cortex-M3 32-bit RISC processor with embedded ICE-RT debug and JTAG interface units. It runs software from the link control (LC) layer, up to the host controller interface (HCI).

The ARM core is paired with a memory unit that contains 668 KB of ROM memory for program storage and boot ROM, 200 KB of RAM for data scratch-pad and patch RAM code. The internal ROM allows for flexibility during power-on reset to enable the same device to be used in various configurations. At power-up, the lower-layer protocol stack is executed from the internal ROM memory.

External patches may be applied to the ROM-based firmware to provide flexibility for bug fixes or features additions. These patches may be downloaded from the host to the BCM43569 through the UART transports.

RAM, ROM, and Patch Memory

The BCM43569 Bluetooth core has 200 KB of internal RAM which is mapped between general-purpose scratch pad memory and patch memory and 668 KB of ROM used for the lower-layer protocol stack, test mode software, and boot ROM. The patch memory capability enables the addition of code changes for purposes of feature additions and bug fixes to the ROM memory.

Reset

The BCM43569 has an integrated power-on reset circuit that resets all circuits to a known power-on state. The BT power-on reset (POR) circuit is out of reset after BT_REG_ON goes high. If BT_REG_ON is low, then the POR circuit is held in reset.

Section 7: BT Peripheral Transport Unit

UART Transport Detection

The BT_HOST_WAKE pin is also used for BT transport detection.

Transport detection occurs during the power-up sequence, based on the following pin state:

- If the BT_HOST_WAKE pin is not pulled low externally during power-up, then the default internal pull-up is detected as high and it selects the UART transport interface.
- If the BT_HOST_WAKE pin is pulled high, it detects the UART/USB interface.

PCM Interface

The BCM43569 supports two independent PCM interfaces that share pins with the serial flash interfaces.

[Table 5](#) shows PCM signal mapping used in this data sheet:

Table 5: PCM-to-Serial Flash Interface Mapping

PCM Interface Pins	Serial Flash Interface Pins
BT_PCM_CLK	BT_SF_CLK
BT_PCM_IN	BT_SF_MISO
BT_PCM_OUT	BT_SF_MOSI
BT_PCM_SYNC	BT_SF_CS_L

The PCM interfaces on the BCM43569 can connect to linear PCM codecs in master or slave mode. In master mode, the BCM43569 generates the BT_PCM_CLK and BT_PCM_SYNC signals, and in slave mode, these signals are provided by another master on the PCM interface and are inputs to the BCM43569.

The configuration of the PCM interface can be adjusted by the host through the use of vendor-specific HCI commands.

Slot Mapping

The BCM43569 supports up to three simultaneous full-duplex SCO or eSCO channels through the PCM interface. These three channels are time-multiplexed onto the single PCM interface by using a time-slotting scheme where the 8 kHz or 16 kHz audio sample interval is divided into as many as 16 slots. The number of slots is dependent on the selected interface rate of 128 kHz, 512 kHz, or 1024 kHz. The corresponding number of slots for these interface rate is 1, 2, 4, 8, and 16, respectively. Transmit and receive PCM data from an SCO channel is always mapped to the same slot. The PCM data output driver tristates its output on unused slots to allow other devices to share the same PCM interface signals. The data output driver tristates its output after the falling edge of the PCM clock during the last bit of the slot.

Frame Synchronization

The BCM43569 supports both short- and long-frame synchronization in both master and slave modes. In short-frame synchronization mode, the frame synchronization signal is an active-high pulse at the audio frame rate that is a single-bit period in width and is synchronized to the rising edge of the bit clock. The PCM slave looks for a high on the falling edge of the bit clock and expects the first bit of the first slot to start at the next rising edge of the clock. In long-frame synchronization mode, the frame synchronization signal is again an active-high pulse at the audio frame rate; however, the duration is 3-bit periods and the pulse starts coincident with the first bit of the first slot.

Data Formatting

The BCM43569 may be configured to generate and accept several different data formats. For conventional narrowband speech mode, the BCM43569 uses 13 of the 16 bits in each PCM frame. The location and order of these 13 bits can be configured to support various data formats on the PCM interface. The remaining three bits are ignored on the input and may be filled with 0s, 1s, a sign bit, or a programmed value on the output. The default format is 13-bit 2s complement data, left justified, and clocked MSB first.

Wideband Speech Support

When the host encodes Wideband Speech (WBS) packets in transparent mode, the encoded packets are transferred over the PCM bus for an eSCO voice connection. In this mode, the PCM bus is typically configured in master mode for a 4 kHz sync rate with 16-bit samples, resulting in a 64 kbps bit rate. The BCM43569 also supports slave transparent mode using a proprietary rate-matching scheme. In SBC-code mode, linear 16-bit data at 16 kHz (256 kbps rate) is transferred over the PCM bus.

Burst PCM Mode

In this mode of operation, the PCM bus runs at a significantly higher rate of operation to allow the host to duty cycle its operation and save current. In this mode of operation, the PCM bus can operate at a rate of up to 24 MHz. This mode of operation is initiated with an HCI command from the host.

PCM Interface Timing

Short Frame Sync, Master Mode

Figure 9: PCM Timing Diagram (Short Frame Sync, Master Mode)

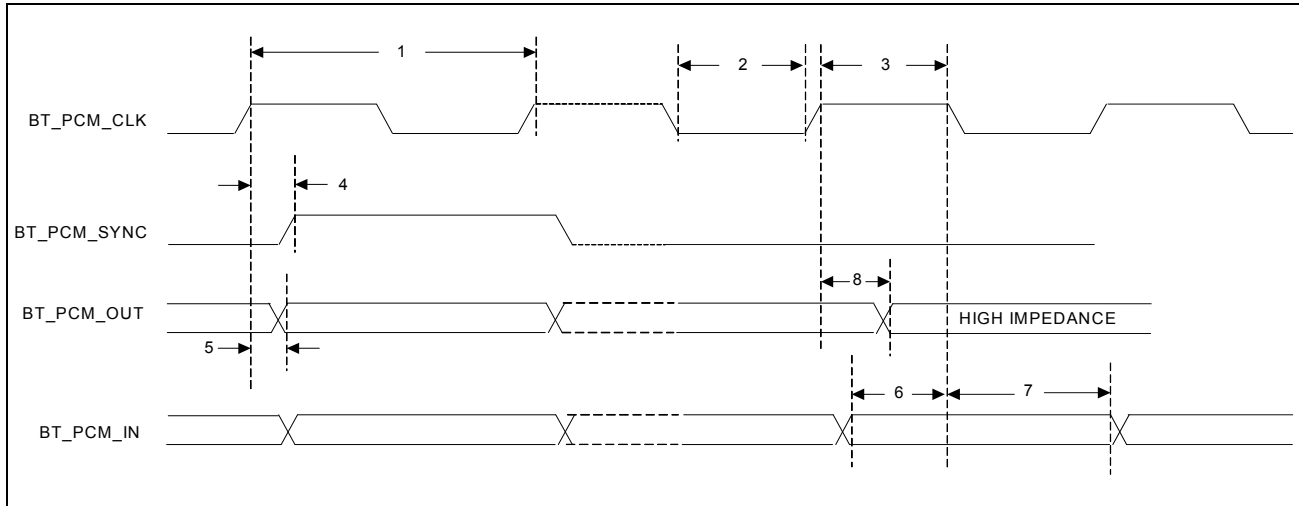

Table 6: PCM Interface Timing Specifications (Short Frame Sync, Master Mode)

Reference	Characteristics	Minimum	Typical	Maximum	Unit
1	PCM bit clock frequency	–	–	12	MHz
2	PCM bit clock low	41	–	–	ns
3	PCM bit clock high	41	–	–	ns
4	PCM_SYNC delay	0	–	25	ns
5	BT_PCM_OUT delay	0	–	25	ns
6	BT_PCM_IN setup	8	–	–	ns
7	BT_PCM_IN hold	8	–	–	ns
8	Delay from rising edge of BT_PCM_CLK during last bit period to BT_PCM_OUT becoming high impedance.	0	–	25	ns

Short Frame Sync, Slave Mode

Figure 10: PCM Timing Diagram (Short Frame Sync, Slave Mode)

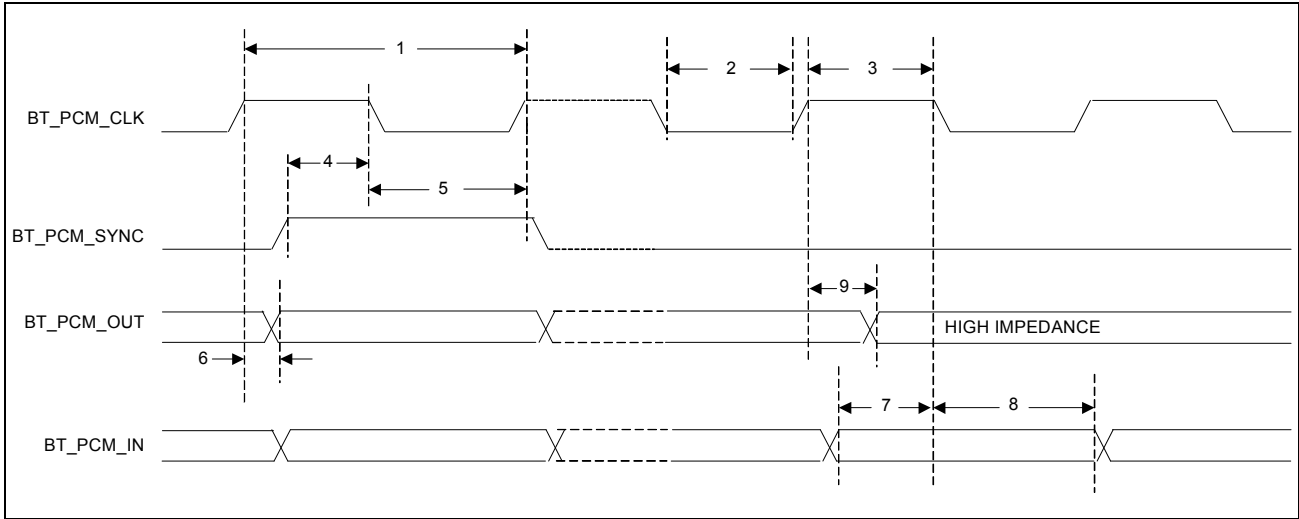

Table 7: PCM Interface Timing Specifications (Short Frame Sync, Slave Mode)

Reference	Characteristics	Minimum	Typical	Maximum	Unit
1	PCM bit clock frequency	–	–	12	MHz
2	PCM bit clock low	41	–	–	ns
3	PCM bit clock high	41	–	–	ns
4	BT_PCM_SYNC setup	8	–	–	ns
5	BT_PCM_SYNC hold	8	–	–	ns
6	BT_PCM_OUT delay	0	–	25	ns
7	BT_PCM_IN setup	8	–	–	ns
8	BT_PCM_IN hold	8	–	–	ns
9	Delay from rising edge of BT_PCM_CLK during last bit period to BT_PCM_OUT becoming high impedance.	0	–	25	ns

Long Frame Sync, Master Mode

Figure 11: PCM Timing Diagram (Long Frame Sync, Master Mode)

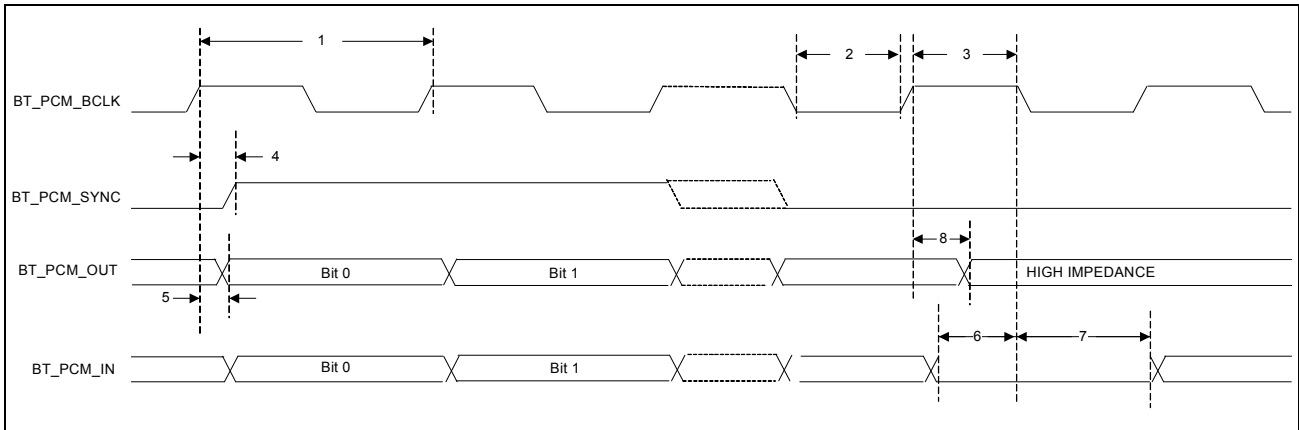

Table 8: PCM Interface Timing Specifications (Long Frame Sync, Master Mode)

Reference	Characteristics	Minimum	Typical	Maximum	Unit
1	PCM bit clock frequency	–	–	12	MHz
2	PCM bit clock low	41	–	–	ns
3	PCM bit clock high	41	–	–	ns
4	BT_PCM_SYNC delay	0	–	25	ns
5	BT_PCM_OUT delay	0	–	25	ns
6	BT_PCM_IN setup	8	–	–	ns
7	BT_PCM_IN hold	8	–	–	ns
8	Delay from rising edge of BT_PCM_CLK during last bit period to BT_PCM_OUT becoming high impedance.	0	–	25	ns

Long Frame Sync, Slave Mode

Figure 12: PCM Timing Diagram (Long Frame Sync, Slave Mode)

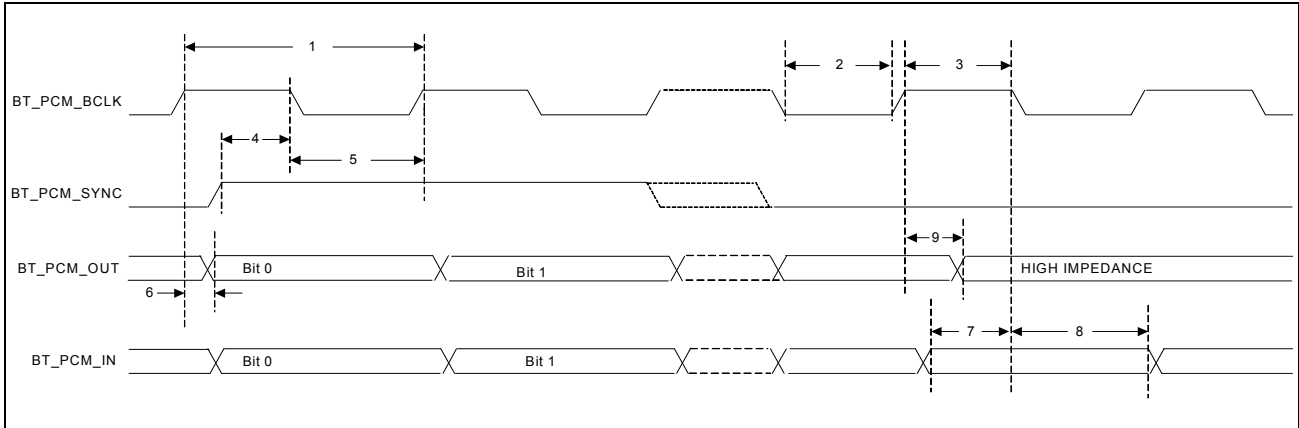

Table 9: PCM Interface Timing Specifications (Long Frame Sync, Slave Mode)

Reference	Characteristics	Minimum	Typical	Maximum	Unit
1	PCM bit clock frequency	–	–	12	MHz
2	PCM bit clock low	41	–	–	ns
3	PCM bit clock high	41	–	–	ns
4	BT_PCM_SYNC setup	8	–	–	ns
5	BT_PCM_SYNC hold	8	–	–	ns
6	BT_PCM_OUT delay	0	–	25	ns
7	BT_PCM_IN setup	8	–	–	ns
8	BT_PCM_IN hold	8	–	–	ns
9	Delay from rising edge of BT_PCM_CLK during last bit period to BT_PCM_OUT becoming high impedance.	0	–	25	ns

Short Frame Sync, Burst Mode

Figure 13: PCM Burst Mode Timing (Receive Only, Short Frame Sync)

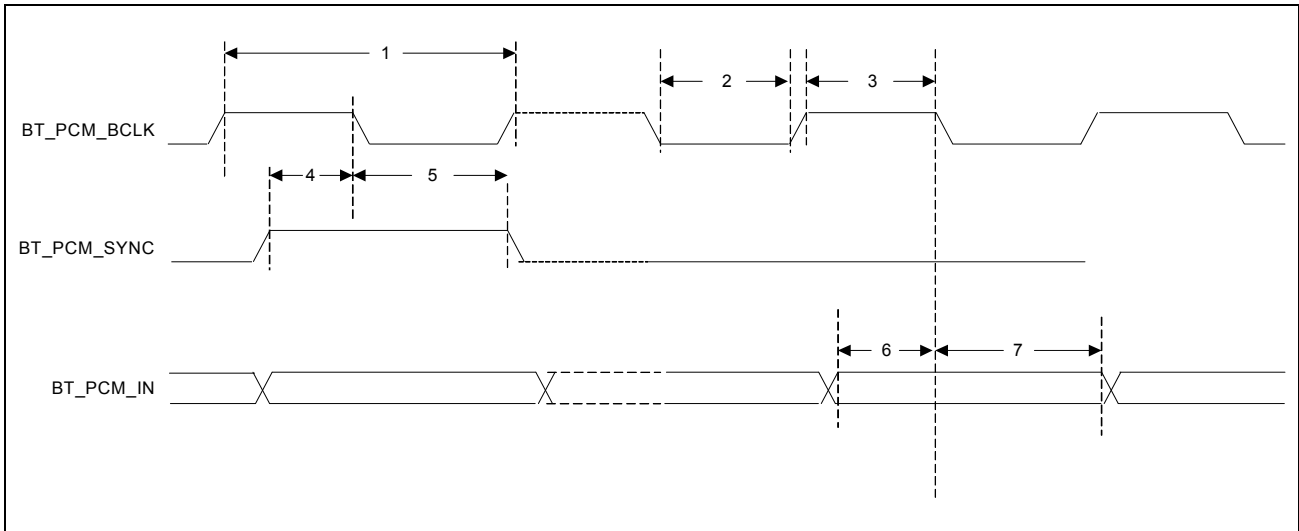

Table 10: PCM Burst Mode (Receive Only, Short Frame Sync)

Reference	Characteristics	Minimum	Typical	Maximum	Unit
1	PCM bit clock frequency	–	–	24	MHz
2	PCM bit clock low	20.8	–	–	ns
3	PCM bit clock high	20.8	–	–	ns
4	BT_PCM_SYNC setup	8	–	–	ns
5	BT_PCM_SYNC hold	8	–	–	ns
6	BT_PCM_IN setup	8	–	–	ns
7	BT_PCM_IN hold	8	–	–	ns

Long Frame Sync, Burst Mode

Figure 14: PCM Burst Mode Timing (Receive Only, Long Frame Sync)

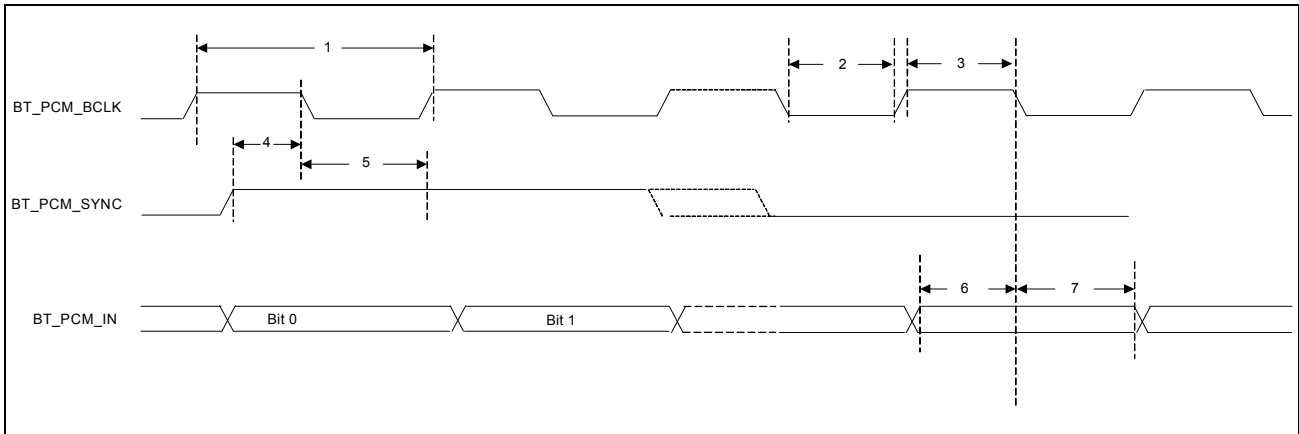

Table 11: PCM Burst Mode (Receive Only, Long Frame Sync)

Reference	Characteristics	Minimum	Typical	Maximum	Unit
1	PCM bit clock frequency	–	–	24	MHz
2	PCM bit clock low	20.8	–	–	ns
3	PCM bit clock high	20.8	–	–	ns
4	BT_PCM_SYNC setup	8	–	–	ns
5	BT_PCM_SYNC hold	8	–	–	ns
6	BT_PCM_IN setup	8	–	–	ns
7	BT_PCM_IN hold	8	–	–	ns

Bluetooth USB Interface

Features

The following USB interface features are supported:

- USB Protocol, Revision 2.0, full-speed (12 Mbps) compliant including the hub
- Optional hub compound device with up to three device cores internal to device
- Bus or self-power, dynamic configuration for the hub
- Global and selective suspend and resume with remote wake-up
- Bluetooth HCI
- HID and DFU

Operation

The BCM43569 can be configured to boot up as either a single USB peripheral or a USB hub with several USB peripherals attached. As a single peripheral, the host detects a single USB Bluetooth device. In hub mode, the host detects a hub with one to three of the ports already connected to USB devices (see [Figure 15](#)).

Figure 15: USB Compounded Device Configuration

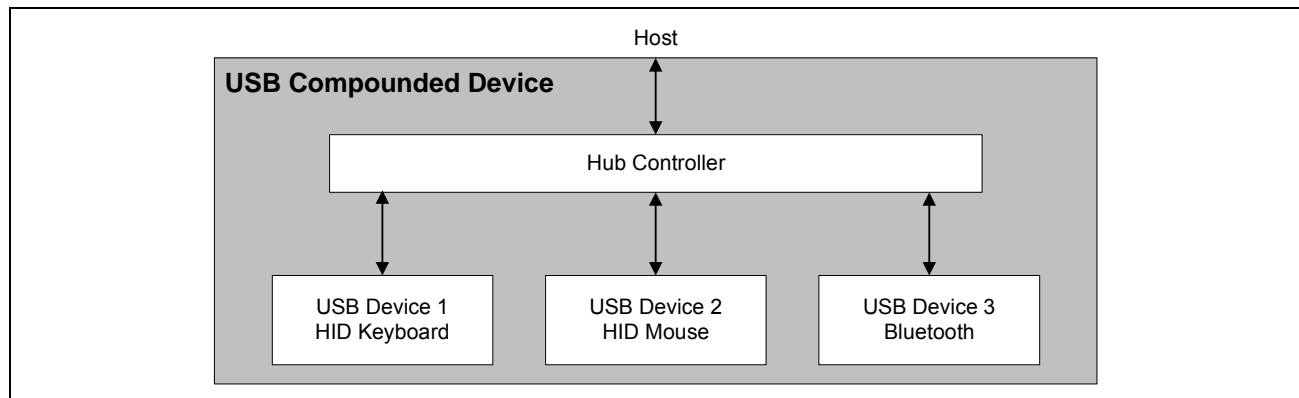

Depending on the desired hub mode configuration, the BCM43569 can boot up showing the three ports connected to logical USB devices internal to the BCM43569: a generic Bluetooth device, a mouse, and a keyboard. In this mode, the mouse and keyboard are emulated devices, since they connect to real HID devices via a Bluetooth link. The Bluetooth link to these HID devices is hidden from the USB host. To the host, the mouse and/or keyboard appear to be directly connected to the USB port.

The USB device, configuration, and string descriptors are fully programmable, allowing manufacturers to customize the descriptors, including vendor and product IDs, the BCM43569 uses to identify itself on the USB port. To make custom USB descriptor information available at boot time, stored it in external NVRAM.

Despite the mode of operation (single peripheral or hub), the Bluetooth device is configured to include the following interfaces:

Interface 0	Contains a Control endpoint (Endpoint 0x00) for HCI commands, a Bulk In Endpoint (Endpoint 0x82) for receiving ACL data, a Bulk Out Endpoint (Endpoint 0x02) for transmitting ACL data, and an Interrupt Endpoint (Endpoint 0x81) for HCI events.
Interface 1	Contains Isochronous In and Out endpoints (Endpoints 0x83 and 0x03) for SCO traffic. Several alternate Interface 1 settings are available for reserving the proper bandwidth of isochronous data (depending on the application).
Interface 2	Contains Bulk In and Bulk Out endpoints (Endpoints 0x84 and 0x04) used for proprietary testing and debugging purposes. These endpoints can be ignored during normal operation.

The BCM43569 supports the USB hub and device model (USB, Revision 2.0, full-speed compliant). When the hub is enabled, the BCM43569 handles all standard USB functions for the following devices:

- HID keyboard
- HID mouse
- Bluetooth

All hub and device descriptors are firmware-programmable. This USB compound device configuration (see [Figure 15 on page 46](#)) supports up to three downstream ports. This configuration can also be programmed to a single USB device core. The device automatically detects activity on the USB interface when connected. Therefore, no special configuration is needed to select HCI as the transport.

The hub's downstream port definition is as follows:

- Port 1 USB lite device core (for HID applications)
- Port 2 USB lite device core (for HID applications)
- Port 3 USB full device core (for Bluetooth applications)

When operating in hub mode, all three internal devices do not have to be enabled. Each internal USB device can be optionally enabled. The configuration record in NVRAM determines which devices are present.

USB Full-Speed Timing

Table 12 and Figure 16 show the timing specifications for the $V_{DD_USB} = 3.3V$, $V_{SS} = 0V$, and $T_A = 0^\circ C$ to $85^\circ C$ operating temperature range.

Table 12: USB Full-Speed Timing Specifications

Reference	Characteristics	Minimum	Maximum	Unit
1	Transition rise time	4	20	ns
2	Transition fall time	4	20	ns
3	Rise/fall timing matching	90	111	%
4	Full-speed data rate	12 – 0.25%	12 + 0.25%	Mb/s

Figure 16: USB Full-Speed Timing

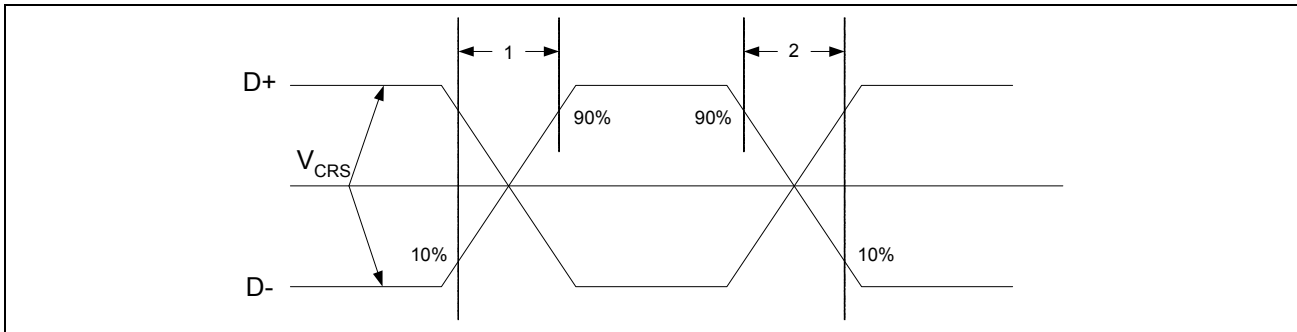

UART Interface

The BCM43569 has a UART host interface for Bluetooth. The UART is a standard 4-wire interface (RX, TX, RTS, and CTS) with adjustable baud rates from 9600 bps to 4.0 Mbps. The interface features an automatic baud rate detection capability that returns a baud rate selection. Alternatively, the baud rate may be selected through a vendor-specific UART HCI command.

The UART has a 1040-byte receive FIFO and a 1040-byte transmit FIFO to support EDR. Access to the FIFOs is conducted through the AHB interface through either DMA or the CPU. The UART supports the Bluetooth 4.1 UART HCI specification: H4, a custom Extended H4, and H5. The default baud rate is 115.2 Kbaud.

The UART supports the 3-wire H5 UART transport, as described in the Bluetooth specification (“Three-wire UART Transport Layer”). Compared to H4, the H5 UART transport reduces the number of signal lines required by eliminating the CTS and RTS signals.

The BCM43569 UART can perform XON/XOFF flow control and includes hardware support for the Serial Line Input Protocol (SLIP). It can also perform wake-on activity. For example, activity on the RX or CTS inputs can wake the chip from a sleep state.

Normally, the UART baud rate is set by a configuration record downloaded after device reset, or by automatic baud rate detection, and the host does not need to adjust the baud rate. Support for changing the baud rate during normal HCI UART operation is included through a vendor-specific command that allows the host to adjust the contents of the baud rate registers. The BCM43569 UARTs operate correctly with the host UART as long as the combined baud rate error of the two devices is within $\pm 2\%$.

Table 13: Example of Common Baud Rates

Desired Rate	Actual Rate	Error (%)
4000000	4000000	0.00
3692000	3692308	0.01
3000000	3000000	0.00
2000000	2000000	0.00
1500000	1500000	0.00
1444444	1454544	0.70
921600	923077	0.16
460800	461538	0.16
230400	230796	0.17
115200	115385	0.16
57600	57692	0.16
38400	38400	0.00
28800	28846	0.16
19200	19200	0.00
14400	14423	0.16
9600	9600	0.00

Figure 17: UART Timing

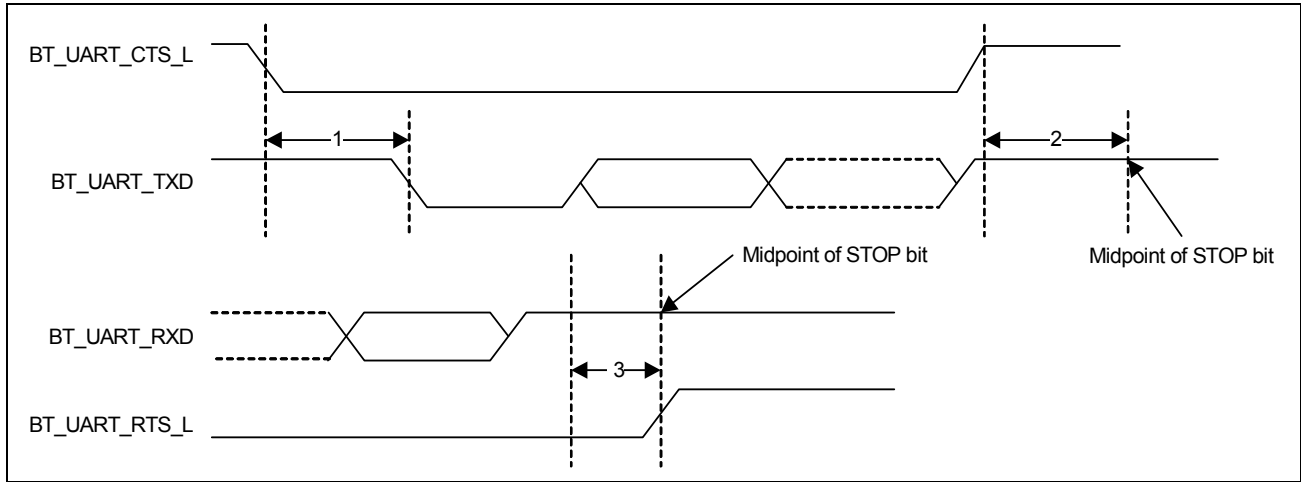

Table 14: UART Timing Specifications

Reference	Characteristics	Minimum	Typical	Maximum	Unit
1	Delay time, BT_UART_CTS_L low to BT_UART_TXD valid	–	–	1.5	Bit periods
2	Setup time, BT_UART_CTS_L high before midpoint of stop bit	–	–	0.5	Bit periods
3	Delay time, midpoint of stop bit to BT_UART_RTS_L high	–	–	0.5	Bit periods

I²S Interface

The BCM43569 supports an I²S digital audio port for Bluetooth audio. The I²S interface supports both master and slave modes. The I²S signals are:

- I²S clock: BT_I2S_CLK
- I²S word select: BT_I2S_WS
- I²S data out: BT_I2S_DO
- I²S data in: BT_I2S_DI

BT_I2S_CLK and BT_I2S_WS become outputs in master mode and inputs in slave mode, whereas BT_I2S_DO always stays as an output. The channel word length is 16 bits, and the data is justified so that the MSB of the left-channel data is aligned with the MSB of the I²S bus, in accord with the I²S specification. The MSB of each data word is transmitted one bit clock cycle after the BT_I2S_WS transition, synchronous with the falling edge of the bit clock. Left-channel data is transmitted when BT_I2S_WS is low, and right-channel data is transmitted when BT_I2S_WS is high. Data bits sent by the BCM43569 are synchronized with the falling edge of BT_I2S_CLK and should be sampled by the receiver on the rising edge of BT_I2S_CLK.

The clock rate in master mode is either of the following:

48 kHz x 32 bits per frame = 1.536 MHz

48 kHz x 50 bits per frame = 2.400 MHz

The master clock is generated from the input reference clock using a N/M clock divider.

In the slave mode, any clock rate is supported to a maximum of 3.072 MHz.

I²S Timing



Note: Timing values specified in Table 15 are relative to high and low threshold levels.

Table 15: Timing for I²S Transmitters and Receivers

	Transmitter				Receiver				Notes
	Lower Limit		Upper Limit		Lower Limit		Upper Limit		
	Min.	Max.	Min.	Max.	Min.	Max.	Min.	Max.	
Clock period T	T_{tr}	–	–	–	T_r	–	–	–	a
Master Mode: Clock generated by transmitter or receiver									
HIGH t_{HC}	$0.35T_{tr}$	–	–	–	$0.35T_{tr}$	–	–	–	b
LOW t_{LC}	$0.35T_{tr}$	–	–	–	$0.35T_{tr}$	–	–	–	b
Slave Mode: Clock accepted by transmitter or receiver									
HIGH t_{HC}	–	$0.35T_{tr}$	–	–	–	$0.35T_{tr}$	–	–	c
LOW t_{LC}	–	$0.35T_{tr}$	–	–	–	$0.35T_{tr}$	–	–	c
Rise time t_{RC}	–	–	$0.15T_{tr}$	–	–	–	–	–	d
Transmitter									
Delay t_{dtr}	–	–	–	$0.8T$	–	–	–	–	e
Hold time t_{htr}	0	–	–	–	–	–	–	–	d
Receiver									
Setup time t_{sr}	–	–	–	–	–	$0.2T_r$	–	–	f
Hold time t_{hr}	–	–	–	–	–	0	–	–	f

- The system clock period T must be greater than T_{tr} and T_r because both the transmitter and receiver have to be able to handle the data transfer rate.
- At all data rates in master mode, the transmitter or receiver generates a clock signal with a fixed mark/space ratio. For this reason, t_{HC} and t_{LC} are specified with respect to T.
- In slave mode, the transmitter and receiver need a clock signal with minimum HIGH and LOW periods so that they can detect the signal. So long as the minimum periods are greater than $0.35T_r$, any clock that meets the requirements can be used.
- Because the delay (t_{dtr}) and the maximum transmitter speed (defined by T_{tr}) are related, a fast transmitter driven by a slow clock edge can result in t_{dtr} not exceeding t_{RC} which means t_{htr} becomes zero or negative. Therefore, the transmitter has to guarantee that t_{htr} is greater than or equal to zero, so long as the clock rise-time t_{RC} is not more than t_{RCmax} , where t_{RCmax} is not less than $0.15T_{tr}$.
- To allow data to be clocked out on a falling edge, the delay is specified with respect to the rising edge of the clock signal and T, always giving the receiver sufficient setup time.
- The data setup and hold time must not be less than the specified receiver setup and hold time.



Note: The time periods specified in Figure 18 and Figure 19 are defined by the transmitter speed. The receiver specifications must match transmitter performance.

Figure 18: I²S Transmitter Timing

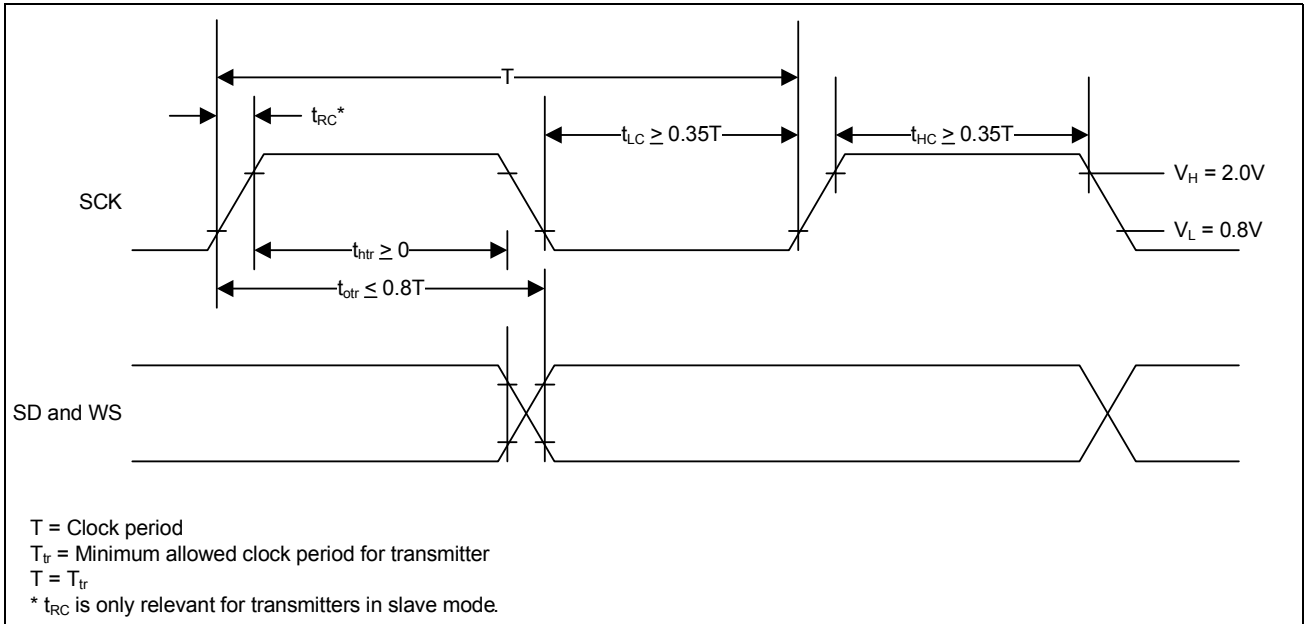
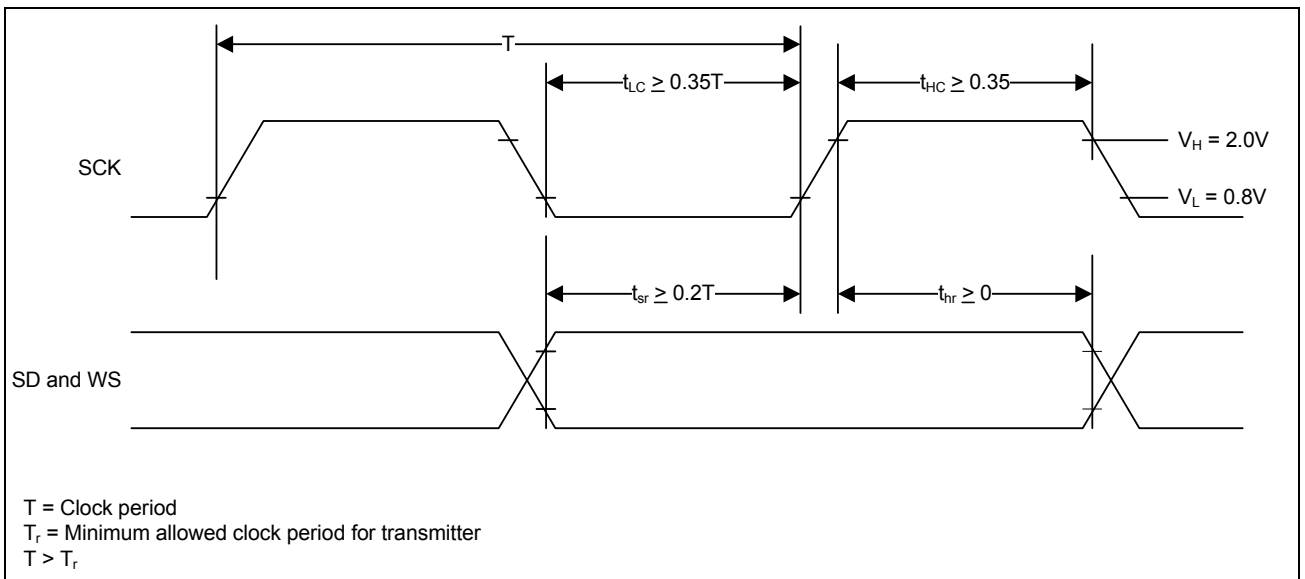

Figure 19: I²S Receiver Timing



Section 8: WLAN Global Functions

WLAN CPU and Memory Subsystem

The BCM43569 WLAN section includes an integrated ARM Cortex-R4 32-bit processor with internal RAM and ROM. The ARM Cortex-R4 is a low-power processor that features low gate count, low interrupt latency, and low-cost debug capabilities. It is intended for deeply embedded applications that require fast interrupt response features. Delivering more than 30% performance gain over ARM7TDMI, the ARM Cortex-R4 implements the ARM v7-R architecture with support for the Thumb-2 instruction set.

At 0.19 $\mu\text{W}/\text{MHz}$, the Cortex-R4 is the most power efficient general-purpose microprocessor available, outperforming 8- and 16-bit devices on MIPS/ μW . It supports integrated sleep modes.

Using multiple technologies to reduce cost, the ARM Cortex-R4 offers improved memory utilization, reduced pin overhead, and reduced silicon area. It supports independent buses for Code and Data access (ICode/DCode and System buses), and extensive debug features including real time trace of program execution.

On-chip memory for the CPU includes 768 KB SRAM and 640 KB ROM.

One-Time Programmable Memory

Various hardware configuration parameters may be stored in an internal one-time programmable (OTP) memory, which is read by the system software after device reset. In addition, customer-specific parameters, including the system vendor ID and the MAC address can be stored, depending on the specific board design. Up to 484 bytes of user-accessible OTP are available.

The initial state of all bits in an unprogrammed OTP device is 0. After any bit is programmed to a 1, it cannot be reprogrammed to 0. The entire OTP array can be programmed in a single write cycle using a utility provided with the Broadcom WLAN manufacturing test tools. Alternatively, multiple write cycles can be used to selectively program specific bytes, but only bits which are still in the 0 state can be altered during each programming cycle.

Prior to OTP programming, all values should be verified using the appropriate editable nvram.txt file, which is provided with the reference board design package.

GPIO Interface

The WLAN section of the BCM43569 supports 16 GPIOs.

Upon power up and reset, these pins become tristated. Subsequently, they can be programmed to be either input or output pins via the GPIO control register. In addition, the GPIO pins can be assigned to various other functions, see [Table 22: "GPIO Alternative Signal Functions," on page 79](#).

WLAN USB 2.0 Interface

Figure 20 details the WLAN USB 2.0 host interface.

Figure 20: WLAN USB 2.0 Host Interface Block Diagram

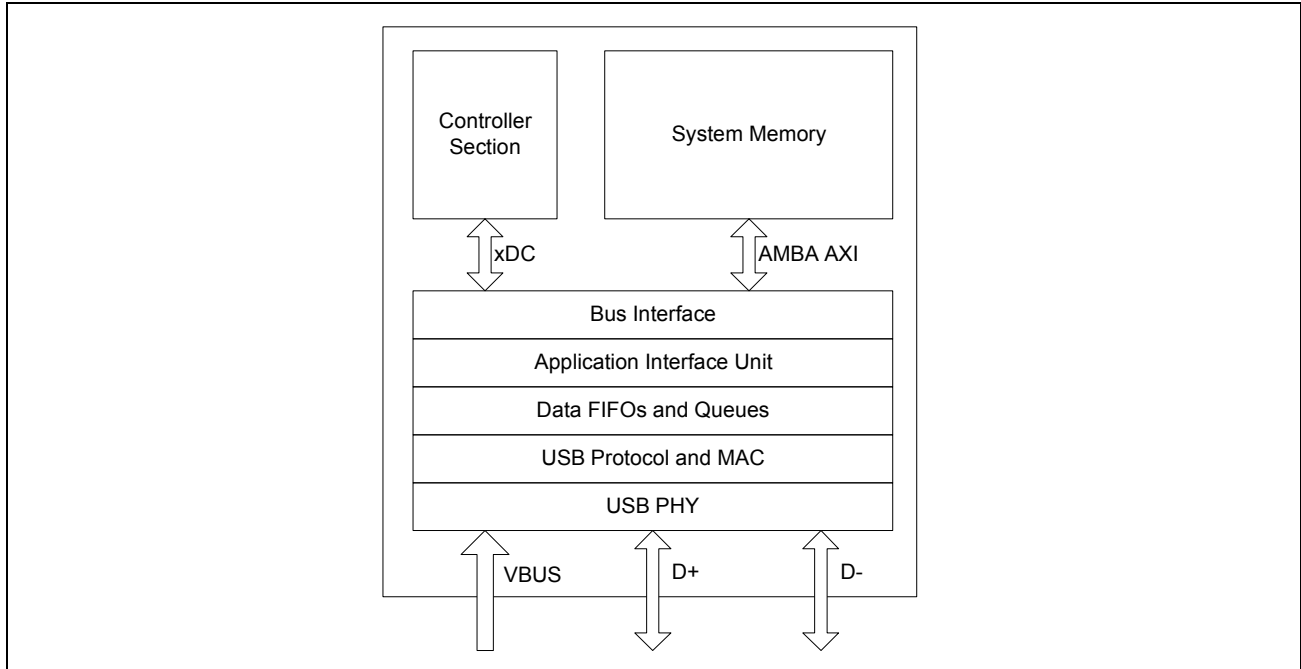

The BCM43569 has an USB 2.0 protocol engine that supports the following hardware interfaces:

- Advanced microcontroller bus architecture (AMBA)/advanced extensible interface (AXI) for an AXI interconnect.
- AMPB advanced peripheral bus (APB) for extensible device controller (xDC) certificate signing request (CSR) access.
- Interrupts
- D+/D- as USB signaling
- VBUS presence is required to indicate that xDC is connected to a host.

The device properties and endpoints [0 to 127] are stored inside the BCM43569 system memory, in which each endpoint consists of transfer ring and is linked to data buffers.

Figure 21: WLAN USB Timing

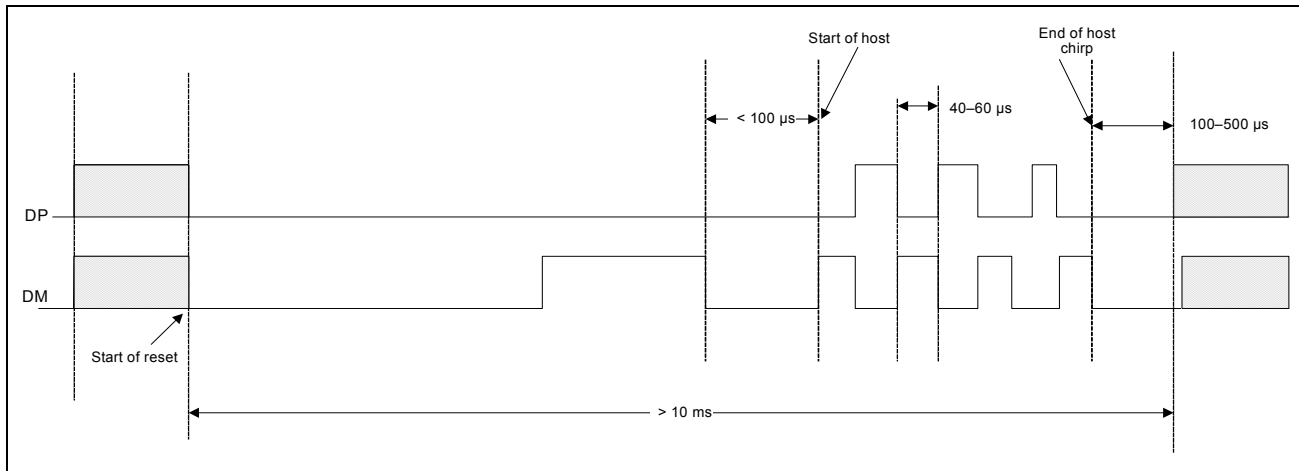

Table 16: USB2.0 Electrical Parameters

Parameter	Symbol	Condition	Min.	Typ.	Max.	Unit
Supply voltage	VDD33	–	2.97	3.30	3.63	V
Operation temperature	TEMP	Die temperature	–40	25	125	°C
Current consumption Suspend mode	ISUSP	3.3V	–	–	500 ^a	μA
Current consumption HS mode	IHSTX	3.3V	–	28	–	mA

a. Refer to USB 2.0 Standard Specification for details (see [Reference \[2\] on page 12](#)).

UART Interface

One 2-wire UART interface can be enabled by software as an alternate function on GPIO pins. Refer to [Table 22: “GPIO Alternative Signal Functions,” on page 79](#). Provided primarily for debugging during development, this UART enables the BCM43569 to operate as RS-232 data termination equipment (DTE) for exchanging and managing data with other serial devices. It is compatible with the industry standard 16550 UART, and provides a FIFO size of 64 × 8 in each direction.

JTAG Interface

The BCM43569 supports the IEEE 1149.1 JTAG boundary scan standard for performing device package and PCB assembly testing during manufacturing. In addition, the JTAG interface allows Broadcom to assist customers by using proprietary debug and characterization test tools during board bring-up. Therefore, it is highly recommended to provide access to the JTAG pins by means of test points or a header on all PCB designs.

Refer to [Table 22: “GPIO Alternative Signal Functions,” on page 79](#) for JTAG pin assignments.

SPROM Interface

The BCM43569 is capable of but is not currently supporting SPROM interface as a main feature.

Various hardware configuration parameters may be stored in an external SPROM instead of the OTP. The SPROM is read by system software after device reset. In addition, depending on the board design, customer-specific parameters may be stored in SPROM.

The four SPROM control signals—SPROM_CS, SPROM_CLK, SPROM_MI, and SPROM_MO are multiplexed on the GPIO interface (see [Table 22: “GPIO Alternative Signal Functions,” on page 79](#) for additional details). By default, the SPROM interface supports 2 kbit serial SPROMs, and it can also support 4 kbit and 16 kbit serial SPROMs by using the appropriate strapping option.

SFLASH Interface

The BCM43569 is capable of but is not currently supporting SFLASH interface as a main feature.

For use only when the HSIC interface mode is selected, an interface to external SFLASH is available.

The four SFLASH control signals —SFLASH_CS#, SFLASH_CLK, SFLASH_MI, and SFLASH_MO are multiplexed on the GPIO interface (see [Table 22: “GPIO Alternative Signal Functions,” on page 79](#) for additional details).

Section 9: Wireless LAN MAC and PHY

IEEE 802.11ac Draft MAC

The BCM43569 WLAN MAC is designed to support high-throughput operation with low-power consumption. It does so without compromising the Bluetooth coexistence policies, thereby enabling optimal performance over both networks. In addition, several power saving modes have been implemented that allow the MAC to consume very little power while maintaining network-wide timing synchronization. The architecture diagram of the MAC is shown in [Figure 22](#).

The following sections provide an overview of the important modules in the MAC.

Figure 22: WLAN MAC Architecture

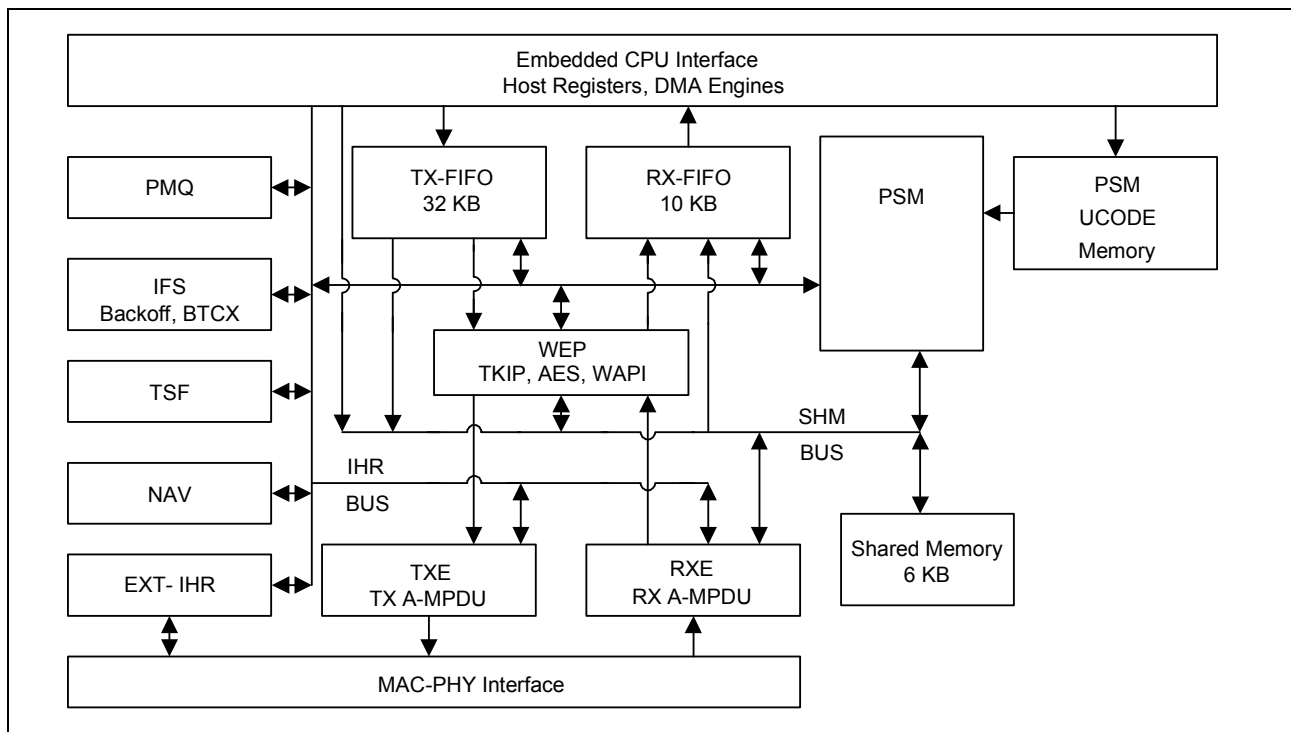

The BCM43569 WLAN media access controller (MAC) supports features specified in the IEEE 802.11 base standard, and amended by IEEE 802.11n. The key MAC features include:

- Enhanced MAC for supporting IEEE 802.11ac Draft features
- Transmission and reception of aggregated MPDUs (A-MPDU) for high throughput (HT)
- Support for power management schemes, including WMM power-save, power-save multi-poll (PSMP) and multiphase PSMP operation
- Support for immediate ACK and Block-ACK policies
- Interframe space timing support, including RIFS

- Support for RTS/CTS and CTS-to-self frame sequences for protecting frame exchanges
- Back-off counters in hardware for supporting multiple priorities as specified in the WMM specification
- Timing synchronization function (TSF), network allocation vector (NAV) maintenance, and target beacon transmission time (TBTT) generation in hardware
- Hardware offload for AES-CCMP, legacy WPA TKIP, legacy WEP ciphers, WAPI, and support for key management
- Support for coexistence with Bluetooth
- Programmable independent basic service set (IBSS) or infrastructure basic service set functionality
- Statistics counters for MIB support

PSM

The programmable state machine (PSM) is a micro-coded engine, which provides most of the low-level control to the hardware, to implement the IEEE 802.11 specification. It is a microcontroller that is highly optimized for flow control operations, which are predominant in implementations of communication protocols. The instruction set and fundamental operations are simple and general, which allows algorithms to be optimized until very late in the design process. It also allows for changes to the algorithms to track evolving IEEE 802.11 specifications.

The PSM fetches instructions from the microcode memory. It uses the shared memory to obtain operands for instructions, as a data store, and to exchange data between both the host and the MAC data pipeline (via the SHM bus). The PSM also uses a scratch-pad memory (similar to a register bank) to store frequently accessed and temporary variables.

The PSM exercises fine-grained control over the hardware engines, by programming internal hardware registers (IHR). These IHRs are co-located with the hardware functions they control, and are accessed by the PSM via the IHR bus.

The PSM fetches instructions from the microcode memory using an address determined by the program counter, instruction literal, or a program stack. For ALU operations the operands are obtained from shared memory, scratch-pad, IHRs, or instruction literals, and the results are written into the shared memory, scratch-pad, or IHRs.

There are two basic branch instructions: conditional branches and ALU based branches. To better support the many decision points in the IEEE 802.11 algorithms, branches can depend on either a readily available signals from the hardware modules (branch condition signals are available to the PSM without polling the IHRs), or on the results of ALU operations.

WEP

The wired equivalent privacy (WEP) engine encapsulates all the hardware accelerators to perform the encryption and decryption, and MIC computation and verification. The accelerators implement the following cipher algorithms: legacy WEP, WPA TKIP, WPA2 AES-CCMP.

The PSM determines, based on the frame type and association information, the appropriate cipher algorithm to be used. It supplies the keys to the hardware engines from an on-chip key table. The WEP interfaces with the TXE to encrypt and compute the MIC on transmit frames, and the RXE to decrypt and verify the MIC on receive frames.

TXE

The transmit engine (TXE) constitutes the transmit data path of the MAC. It coordinates the DMA engines to store the transmit frames in the TXFIFO. It interfaces with WEP module to encrypt frames, and transfers the frames across the MAC-PHY interface at the appropriate time determined by the channel access mechanisms.

The data received from the DMA engines are stored in transmit FIFOs. The MAC supports multiple logical queues to support traffic streams that have different QoS priority requirements. The PSM uses the channel access information from the IFS module to schedule a queue from which the next frame is transmitted. Once the frame is scheduled, the TXE hardware transmits the frame based on a precise timing trigger received from the IFS module.

The TXE module also contains the hardware that allows the rapid assembly of MPDUs into an A-MPDU for transmission. The hardware module aggregates the encrypted MPDUs by adding appropriate headers and pad delimiters as needed.

RXE

The receive engine (RXE) constitutes the receive data path of the MAC. It interfaces with the DMA engine to drain the received frames from the RXFIFO. It transfers bytes across the MAC-PHY interface and interfaces with the WEP module to decrypt frames. The decrypted data is stored in the RXFIFO.

The RXE module contains programmable filters that are programmed by the PSM to accept or filter frames based on several criteria such as receiver address, BSSID, and certain frame types.

The RXE module also contains the hardware required to detect A-MPDUs, parse the headers of the containers, and disaggregate them into component MPDUS.

IFS

The IFS module contains the timers required to determine interframe space timing including RIFS timing. It also contains multiple backoff engines required to support prioritized access to the medium as specified by WMM.

The interframe spacing timers are triggered by the cessation of channel activity on the medium, as indicated by the PHY. These timers provide precise timing to the TXE to begin frame transmission. The TXE uses this information to send response frames or perform transmit frame-bursting (RIFS or SIFS separated, as within a TXOP).

The backoff engines (for each access category) monitor channel activity, in each slot duration, to determine whether to continue or pause the backoff counters. When the backoff counters reach 0, the TXE gets notified, so that it may commence frame transmission. In the event of multiple backoff counters decrementing to 0 at the same time, the hardware resolves the conflict based on policies provided by the PSM.

The IFS module also incorporates hardware that allows the MAC to enter a low-power state when operating under the IEEE power save mode. In this mode, the MAC is in a suspended state with its clock turned off. A sleep timer, whose count value is initialized by the PSM, runs on a slow clock and determines the duration over which the MAC remains in this suspended state. Once the timer expires the MAC is restored to its functional state. The PSM updates the TSF timer based on the sleep duration ensuring that the TSF is synchronized to the network. The IFS module also contains the PTA hardware that assists the PSM in Bluetooth coexistence functions.

TSF

The timing synchronization function (TSF) module maintains the TSF timer of the MAC. It also maintains the target beacon transmission time (TBTT). The TSF timer hardware, under the control of the PSM, is capable of adopting timestamps received from beacon and probe response frames in order to maintain synchronization with the network.

The TSF module also generates trigger signals for events that are specified as offsets from the TSF timer, such as uplink and downlink transmission times used in PSMP.

NAV

The network allocation vector (NAV) timer module is responsible for maintaining the NAV information conveyed through the duration field of MAC frames. This ensures that the MAC complies with the protection mechanisms specified in the standard.

The hardware, under the control of the PSM, maintains the NAV timer and updates the timer appropriately based on received frames. This timing information is provided to the IFS module, which uses it as a virtual carrier-sense indication.

MAC-PHY Interface

The MAC-PHY interface consists of a data path interface to exchange RX/TX data from/to the PHY. In addition, there is an programming interface, which can be controlled either by the host or the PSM to configure and control the PHY.

IEEE 802.11ac Draft PHY

The BCM43569 WLAN Digital PHY is designed to comply with IEEE 802.11ac Draft and IEEE 802.11a/b/g/n dual-stream specifications to provide wireless LAN connectivity supporting data rates from 1 Mbps to 866.7 Mbps for low-power, high-performance applications.

The PHY has been designed to work in the presence of interference, radio nonlinearity, and various other impairments. It incorporates optimized implementations of the filters, FFT and Viterbi decoder algorithms. Efficient algorithms have been designed to achieve maximum throughput and reliability, including algorithms for carrier sense/rejection, frequency/phase/timing acquisition and tracking, channel estimation and tracking. The PHY receiver also contains a robust IEEE 802.11b demodulator. The PHY carrier sense has been tuned to provide high throughput for IEEE 802.11g/11b hybrid networks with Bluetooth coexistence.

The key PHY features include:

- Programmable data rates from MCS0–MCS15 in 20 MHz, 40 MHz, and 80 MHz channels, as specified in IEEE 802.11ac Draft
- Supports Optional Short GI and Green Field modes in TX and RX
- TX and RX LDPC for improved range and power efficiency
- Beamforming support
- All scrambling, encoding, forward error correction, and modulation in the transmit direction and inverse operations in the receive direction.
- Supports IEEE 802.11h/k for worldwide operation
- Advanced algorithms for low power, enhanced sensitivity, range, and reliability
- Algorithms to improve performance in presence of Bluetooth
- Closed loop transmit power control
- Digital RF chip calibration algorithms to handle CMOS RF chip non-idealities
- On-the-fly channel frequency and transmit power selection
- Supports per packet RX antenna diversity
- Available per-packet channel quality and signal strength measurements
- Designed to meet FCC and other worldwide regulatory requirements

Figure 23: WLAN PHY Block Diagram

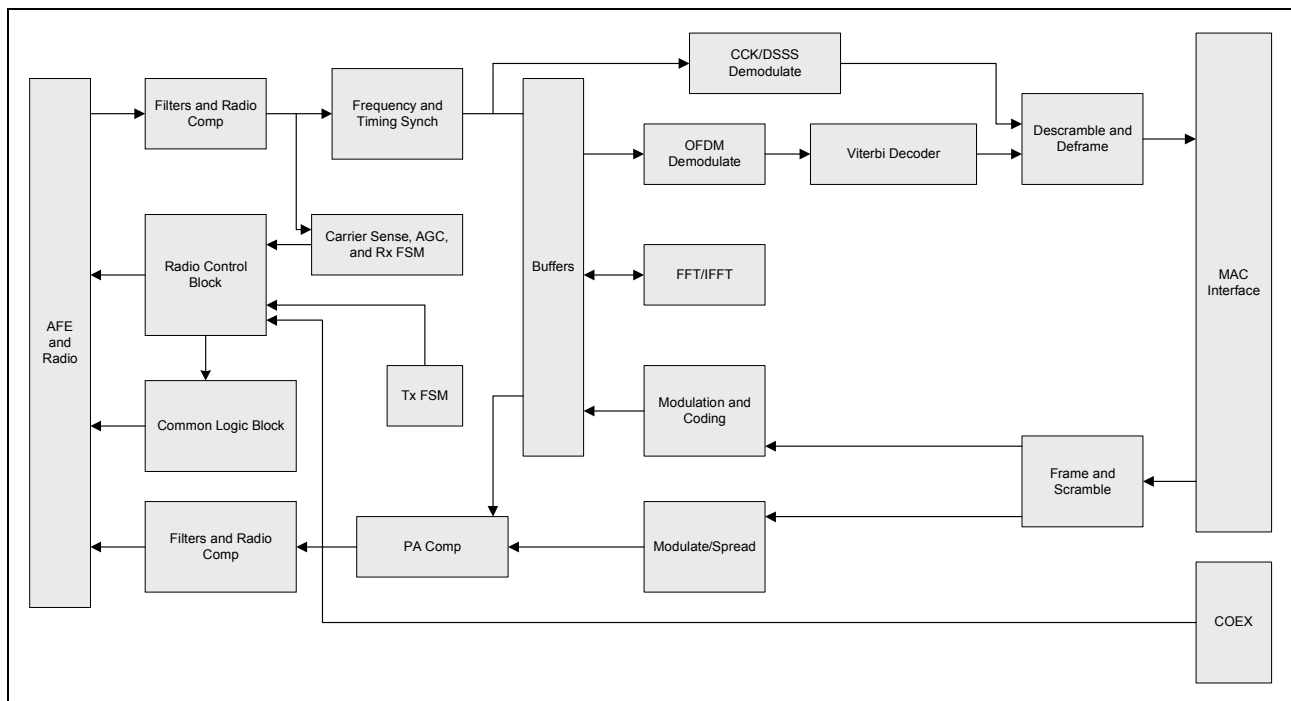

Section 10: WLAN Radio Subsystem

The BCM43569 includes an integrated dual-band WLAN RF transceiver that has been optimized for use in 2.4 GHz and 5 GHz Wireless LAN systems. It has been designed to provide low-power, low-cost, and robust communications for applications operating in the globally available 2.4 GHz unlicensed ISM or 5 GHz U-NII bands. The transmit and receive sections include all on-chip filtering, mixing, and gain control functions.

Sixteen RF control signals are available (eight per core) to drive external RF switches and support optional external power amplifiers and low-noise amplifiers for each band. See the reference board schematics for further details.

Receiver Path

The BCM43569 has a wide dynamic range, direct conversion receiver that employs high-order on-chip channel filtering to ensure reliable operation in the noisy 2.4 GHz ISM band or the entire 5 GHz U-NII band. Control signals are available that can support the use of optional LNAs for each band, which can increase the receive sensitivity by several decibels.

Transmitter Path

Baseband data is modulated and upconverted to the 2.4 GHz ISM or 5-GHz U-NII bands, respectively. Linear on-chip power amplifiers are included, which are capable of delivering high output powers while meeting IEEE 802.11ac and IEEE 802.11a/b/g/n specifications without the need for external PAs. When using the internal PAs, closed-loop output power control is completely integrated.

Calibration

The BCM43569 features dynamic and automatic on-chip calibration to continually compensate for temperature and process variations across components. These calibration routines are performed periodically in the course of normal radio operation. Examples of some of the automatic calibration algorithms are baseband filter calibration for optimum transmit and receive performance, and LOFT calibration for carrier leakage reduction. In addition, I/Q Calibration, R Calibration, and VCO Calibration are performed on-chip. No per-board calibration is required in manufacturing test, which helps to minimize the test time and cost in large volume production.

Section 11: Ball Map and Signal Descriptions

Ball Map

Figure 24 and Figure 25 on page 66 show the FCBGA ball map.

Figure 24: FCBGA Ball Map, 10 mm × 10 mm Array, 254 Balls, A1–AC12 (Top View, Balls Facing Down)

	1	2	3	4	5	6	7	8	9	10	11	12
A	VSSC	GPIO_5				USB2_DP	USB2_AVSSBG	USB2_RREF	USB3_RDP		USB3_TDP	
B	BT_USB_DN	VSSC	GPIO_6	GPIO_2		USB2_DM	USB2_AVSS		USB3_RDN		USB3_TDN	
C	BT_USB_DP	BT_SF_CLK			USB2_AVDD3P3			USB2_AVDD1P2			USB3_TRGND	
D		BT_SF_CS_L										USB3_PVDD1P2
E	BT_UART_RXD	BT_UART_CTS_L			BT_I2S_WS	OTP_VDD033	LPO_IN		USB2_MONPLL	USB2_MONCDR		USB3_TRVDD1P2
F		BT_UART_TXD			BT_SF_MSO							USB3_DVDD1P2
G	BT_I2S_CLK	GPIO_4			BT_GPIO_4							
H					BT_SF_MOSI			BT_I2S_DO		BT_I2S_DI		VSSC
J	BT_DEV_WAKE	BT_HOST_WAKE			BT_CLK_REQ							VSS
K	BT_IFVDD1P2	BT_VCOVDD1P2			BTRGND			BTRGND		AVDD_BBPLL		VDDC
L	BT_LNAVDD1P2	BT_FLVDD1P2						BTRGND	AVSS_BBPLL		VDD	
M		BTRGND			BT_GPIO_2			BT_VDDO		BT_VDDC		
N	BT_RF				BT_GPIO_3			BTRGND		BT_VDDC		
P	BT_PAVDD02P5				BT_GPIO_5			BTRGND		BTRGND	VDDC	VDDC
R	BTRGND	BTRGND			BTRGND		BTRGND		BTRGND		VSSC	VSSC
T	WRF_RFIN_2G_CORE0	RGND			RGND		RGND			RGND		
U	RGND	RGND			RGND							
V	WRF_RFOUT_2G_CORE0	RGND			RGND	RGND	RGND	RGND	RGND			
W	RGND				RGND	RGND	WRF_TSSI_A_CORE0	RGND	WRF_GPIO_OUT_CORE0	WRF_PFD_GND1P2	WRF_CP_GND1P2	WRF_MMD_GND1P2
Y	WRF_PA2G_VBAT_VDD3P3_CORE0											
AA	WRF_PADRV_VBAT_VDD3P3_CORE0	RGND										
AB	WRF_PA5G_VBAT_VDD3P3_CORE0	RGND		RGND	RGND		RGND	RGND	RGND	RGND	RGND	
AC	RGND	WRF_RFOUT_5G_CORE0	RGND	WRF_RFIN_5G_CORE0	RGND	WRF_BUCK_VDD1P5_CORE0	WRF_PFD_VDD1P2	WRF_MMD_VDD1P2	WRF_SYNTH_VBAT_VDD3P3	RGND	WRF_RFIN_2G_CORE1	RGND
	1	2	3	4	5	6	7	8	9	10	11	12

Figure 25: FCBGA Ball Map, 10 mm x 10 mm Array, 254 Balls, A12–AC23 (Top View, Balls Facing Down)

12	13	14	15	16	17	18	19	20	21	22	23		
	USB3_PTESTP		USB3_REFCLKN	BT_UART_RTS_L	VOUT_CLDO	VSSC	VSSC	SR_VLX	SR_VLX	SR_PVSS	SR_PVSS	A	
	USB3_PTESTN		USB3_REFCLKP		GPIO_1	GPIO_0					SR_VDDBAT5V	B	
	USB3_PGND	NC								SR_VDDBATPSV	SR_VDDBATPSV	C	
USB3_PVDD1P2	NC	NC								LDO_VDD1P5	LDO_VDD1P5	D	
USB3_TRVDD1P2		JTAG_SEL	GPIO_3	VSSC	PMU_AVSS	WL_REG_ON				VOUT_LDO3P3_B	VOUT_LDO3P3_B	E	
USB3_DVDD1P2	NC						VOUT_3P3_SENSE			VOUT_3P3	VOUT_3P3	F	
	NC									LDO_VDDBAT5V	LDO_VDDBAT5V	G	
VSSC	VSSC		BT_REG_ON	VSSC			GPIO_15			GPIO_14	VOUT_BTLD02P5	H	
VSS		VSS		VDDIO_PMU			GPIO_12			GPIO_11	VOUT_UNLDO	J	
VDDC		VDDC		VDDIO			GPIO_9			GPIO_13	RF_SW_CTRL_13	K	
		VDDC	VDDC	VDDIO_RF			RF_SW_CTRL_15			GPIO_10	RF_SW_CTRL_12	L	
							RF_SW_CTRL_14			GPIO_8	RF_SW_CTRL_11	M	
			VDDC				RF_SW_CTRL_6			GPIO_7	RF_SW_CTRL_10	N	
VDDC		VDDC	VDDC	VSSC			RF_SW_CTRL_4			RF_SW_CTRL_9		P	
VSSC	VSSC	VSSC	VSSC	VSSC	VSSC		RF_SW_CTRL_5			RF_SW_CTRL_7	RF_SW_CTRL_8	R	
	VSSC		VSSC	VSSC			RF_SW_CTRL_3					T	
	RGND			RGND	RGND		RF_SW_CTRL_0			WRF_XTAL_GND1P2	WRF_XTAL_OUT	U	
	WRF_LOGENG_GND1P2			RGND	RGND	RGND	RF_SW_CTRL_2			WRF_XTAL_GND1P2	WRF_XTAL_IN	V	
WRF_MMIO_GND1P2	WRF_VCO_GND1P2	WRF_GPIO_OUT_CORE1	RGND	WRF_TSSI_A_CORE1	RGND	RGND	RF_SW_CTRL_1			WRF_XTAL_GND1P2	WRF_XTAL_VDD1P2	W	
										WRF_XTAL_GND1P2	WRF_XTAL_VDD1P5	Y	
										RGND	WRF_BUCK_VDD1P5_CORE1	AA	
	RGND		RGND	RGND		RGND	RGND	RGND	RGND	RGND	RGND	AB	
RGND	WRF_RFOUT_2G_CORE1	RGND	WRF_PA2G_VBAT_VDD3P3_CORE1	WRF_PADRV_VBAT_VDD3P3_CORE1	WRF_PA5G_VBAT_VDD3P3_CORE1	RGND	RGND	WRF_RFOUT_5G_CORE1	RGND	WRF_RFIN_5G_CORE1	RGND	AC	
12	13	14	15	16	17	18	19	20	21	22	23		

Pin List

Table 17: Pin List

Ball	Name
A1	VSSC
A2	GPIO_5
A6	USB2_DP
A7	USB2_AVSSBG
A8	USB2_RREF
A9	USB3_RDP
A11	USB3_TDP
A13	USB3_PTESTP
A15	USB3_REFCLKN
A16	BT_UART_RTS_L
A17	VOUT_CLDO
A20	SR_VLX
A21	SR_VLX
A22	SR_PVSS
A23	SR_PVSS
B1	BT_USB_DN
B2	VSSC
B3	GPIO_6
B4	GPIO_2
B6	USB2_DM
B7	USB2_AVSS
B9	PCIE_AVSS
B11	USB3_TDN
B12	PCIE_AVSS
B13	USB3_PTESTN
B15	USB3_REFCLKP
B17	GPIO_1
B18	GPIO_0
B23	SR_VDDBATA5V
C1	BT_USB_DP
C2	BT_SF_CLK
C5	USB2_AVDD3P3
C8	USB2_AVDD1P2
C11	USB3_TRGND
C13	USB3_PGND
C14	NC
C22	SR_VDDBATP5V

Table 17: Pin List (Cont.)

Ball	Name
C23	SR_VDDBATP5V
D2	BT_SF_CS_L
D12	USB3_PVDD1P2
D13	NC
D14	NC
D22	LDO_VDD1P5
D23	LDO_VDD1P5
E1	BT_UART_RXD
E2	BT_UART_CTS_L
E5	BT_I2S_WS
E6	OTP_VDD33
E7	LPO_IN
E9	USB2_MONPLL
E10	USB2_MONCDR
E11	VSSC
E12	USB3_TRVDD1P2
E14	JTAG_SEL
E15	GPIO_3
E17	PMU_AVSS
E18	WL_REG_ON
E22	VOUT_LDO3P3_B
E23	VOUT_LDO3P3_B
F2	BT_UART_TXD
F5	BT_SF_MISO
F12	USB3_DVDD1P2
F13	HSIC_AVDD12
F19	VOUT_3P3_SENSE
F22	VOUT_3P3
F23	VOUT_3P3
G1	BT_I2S_CLK
G2	GPIO_4
G5	BT_GPIO_4
G13	HSIC_AGND12
G22	LDO_VDDBAT5V
G23	LDO_VDDBAT5V
H5	BT_SF_MOSI
H8	BT_I2S_DO

Table 17: Pin List (Cont.)

Ball	Name
H10	BT_I2S_DI
H12	VSSC
H13	VSSC
H15	BT_REG_ON
H16	VSSC
H19	GPIO_15
H22	GPIO_14
H23	VOUT_BTLDO2P5
J1	BT_DEV_WAKE
J2	BT_HOST_WAKE
J5	BT_CLK_REQ
J12	VSSC
J14	VSSC
J16	VDDIO_PMU
J19	GPIO_12
J22	GPIO_11
J23	VOUT_LNLDO
K1	BT_IFVDD1P2
K2	BT_VCOVDD1P2
K5	BTRGND
K10	AVDD_BBPLL
K12	VDDC
K14	VDDC
K16	VDDIO
K19	GPIO_9
K22	GPIO_13
K23	RF_SW_CTRL_13
L1	BT_LNAVDD1P2
L8	BTRGND
L9	AVSS_BBPLL
L11	VDDC
L14	VDDC
L15	VDDC
L16	VDDIO_RF
L19	RF_SW_CTRL_15
M2	BTRGND
M5	BT_GPIO_2
M8	BT_VDDO
M10	BT_VDDC

Table 17: Pin List (Cont.)

Ball	Name
M19	RF_SW_CTRL_14
M22	GPIO_8
M23	RF_SW_CTRL_11
N1	BT_RF
N5	BT_GPIO_3
N8	BTRGND
N15	VDDC
N19	RF_SW_CTRL_6
N22	GPIO_7
N23	RF_SW_CTRL_10
P1	BT_PAVDD2P5
P5	BT_GPIO_5
P8	BTRGND
P10	BTRGND
P12	VDDC
P14	VDDC
P15	VDDC
P16	VSSC
P19	RF_SW_CTRL_4
P22	RF_SW_CTRL_9
R1	BTRGND
R2	BTRGND
R5	BTRGND
R7	BTRGND
R9	BTRGND
R11	VSSC
R12	VSSC
R13	VSSC
R14	VSSC
R15	VSSC
R16	VSSC
R17	VSSC
R19	RF_SW_CTRL_5
R22	RF_SW_CTRL_7
R23	RF_SW_CTRL_8
T1	WRF_RFIN_2G_CORE0
T2	RGND
T5	RGND
T7	RGND

Table 17: Pin List (Cont.)

Ball	Name
T10	RGND
T13	VSSC
T15	VSSC
T16	VSSC
T19	RF_SW_CTRL_3
U1	RGND
U2	RGND
U5	RGND
U13	RGND
U16	RGND
U19	RF_SW_CTRL_0
U22	WRF_XTAL_GND1P2
U23	WRF_XTAL_OUT
V1	WRF_RFOUT_2G_CORE0
V2	RGND
V5	RGND
V6	RGND
V7	RGND
V8	RGND
V9	RGND
V13	WRF_LOGENG_GND1P2
V16	RGND
V17	RGND
V18	RGND
V19	RF_SW_CTRL_2
V22	WRF_XTAL_GND1P2
V23	WRF_XTAL_IN
W1	RGND
W5	RGND
W6	RGND
W7	WRF_TSSI_A_CORE0
W8	RGND
W9	WRF_GPIO_OUT_CORE0
W10	WRF_PFD_GND1P2
W11	WRF_CP_GND1P2
W12	WRF_MMD_GND1P2
W13	WRF_VCO_GND1P2
W14	WRF_GPIO_OUT_CORE1
W15	RGND

Table 17: Pin List (Cont.)

Ball	Name
W16	WRF_TSSI_A_CORE1
W17	RGND
W18	RGND
W19	RF_SW_CTRL_1
W22	WRF_XTAL_GND1P2
W23	WRF_XTAL_VDD1P2
Y1	WRF_PA2G_VBAT_VDD3P3_CORE0
Y1	WRF_PA2G_VBAT_VDD3P3_CORE0
Y2	RGND
Y22	WRF_XTAL_GND1P2
Y23	WRF_XTAL_VDD1P5
AA1	WRF_PADRV_VBAT_VDD3P3_CORE0
AA2	RGND
AA22	RGND
AA23	WRF_BUCK_VDD1P5_CORE1
AB1	WRF_PA5G_VBAT_VDD3P3_CORE0
AB2	RGND
AB4	RGND
AB5	RGND
AB7	RGND
AB8	RGND
AB9	RGND
AB10	RGND
AB11	RGND
AB13	RGND
AB15	RGND
AB16	RGND
AB18	RGND
AB19	RGND
AB20	RGND
AB21	RGND
AB22	RGND
AB23	RGND
AC1	RGND
AC2	WRF_RFOUT_5G_CORE0
AC3	RGND
AC4	WRF_RFIN_5G_CORE0
AC5	RGND
AC6	WRF_BUCK_VDD1P5_CORE0

Table 17: Pin List (Cont.)

Ball	Name
AC7	WRF_PFD_VDD1P2
AC8	WRF_MMD_VDD1P2
AC9	WRF_SYNTN_VBAT_VDD3P3
AC10	RGND
AC11	WRF_RFIN_2G_CORE1
AC12	RGND
AC13	WRF_RFOUT_2G_CORE1
AC14	RGND
AC15	WRF_PA2G_VBAT_VDD3P3_CORE1
AC16	WRF_PADRV_VBAT_VDD3P3_CORE1
AC17	WRF_PA5G_VBAT_VDD3P3_CORE1
AC18	RGND
AC19	RGND
AC20	WRF_RFOUT_5G_CORE1
AC21	RGND
AC22	WRF_RFIN_5G_CORE1
AC23	RGND

Signal Descriptions

The signal name, type, and description of each pin in the BCM43569 is listed in [Table 18](#). The symbols shown under Type indicate pin directions (I/O = bidirectional, I = input, O = output) and the internal pull-up/pull-down characteristics (PU = weak internal pull-up resistor and PD = weak internal pull-down resistor), if any.

Table 18: Signal Descriptions

Ball#	Signal Name	Type	Description
WLAN Receive RF Signal Interface			
T1	WRF_RFIN_2G_CORE0	I	2.4 GHz WLAN CORE0 receiver input.
AC11	WRF_RFIN_2G_CORE1	I	2.4 GHz WLAN CORE1 receiver input.
AC4	WRF_RFIN_5G_CORE0	I	5 GHz WLAN CORE0 receiver input.
AC22	WRF_RFIN_5G_CORE1	I	5 GHz WLAN CORE1 receiver input.
V1	WRF_RFOUT_2G_CORE0	O	2.4 GHz WLAN CORE0 PA output.
AC13	WRF_RFOUT_2G_CORE1	O	2.4 GHz WLAN CORE1 PA output.
AC2	WRF_RFOUT_5G_CORE0	O	5 GHz WLAN CORE0 PA output.
AC20	WRF_RFOUT_5G_CORE1	O	5 GHz WLAN CORE1 PA output.
W7	WRF_TSSI_A_CORE0	I	5 GHz TSSI CORE0 input.
W16	WRF_TSSI_A_CORE1	I	5 GHz TSSI CORE1 input.
W9	WRF_GPIO_OUT_CORE0	I/O	GPIO or 2.4 GHz TSSI CORE0 input.
W14	WRF_GPIO_OUT_CORE1	I/O	GPIO or 2.4 GHz TSSI CORE1 input.
RF Switch Control Lines			
U19	RF_SW_CTRL_0	O	Programmable RF switch control lines. The control lines are programmable via the driver and NVRAM file.
W19	RF_SW_CTRL_1	O	
V19	RF_SW_CTRL_2	O	
T19	RF_SW_CTRL_3	O	
P19	RF_SW_CTRL_4	O	
R19	RF_SW_CTRL_5	O	
N19	RF_SW_CTRL_6	O	
R22	RF_SW_CTRL_7	O	
R23	RF_SW_CTRL_8	O	
P22	RF_SW_CTRL_9	O	
N23	RF_SW_CTRL_10	O	
M23	RF_SW_CTRL_11	O	
L23	RF_SW_CTRL_12	O	
K23	RF_SW_CTRL_13	O	
M19	RF_SW_CTRL_14	O	
L19	RF_SW_CTRL_15	O	

Table 18: Signal Descriptions (Cont.)

Ball#	Signal Name	Type	Description
WLAN USB 2.0 Interface			
A8	USB2_RREF	I	USB resistance reference. This pin should be connected to an external 4.75 kΩ 1% resistor in parallel with a 100 pF capacitor to ground.
A6	USB2_DP	I/O	USB 2.0 data+.
B6	USB2_DM	I/O	USB 2.0 data-.
E9	USB2_MONPLL	O	USB 2.0 test pin.
E10	USB2_MONCDR	O	USB 2.0 test pin.
WLAN USB 3.0 Interface			
A9	USB3_RDP	I	Differential pair, receive data, positive.
B9	USB3_RDN	I	Differential pair, receive data, negative.
A11	USB3_TDP	O	Differential pair, transmit data, positive.
B11	USB3_TDN	O	Differential pair, transmit data, negative.
A15	USB3_REFCLKN	O	Differential pair, reference clock, negative.
B15	USB3_REFCLKP	O	Differential pair, reference clock, positive.
A13	USB3_PTESTP	O	Differential pair, test pin, positive.
B13	USB3_PTESTN	O	Differential pair, test pin, negative.
WLAN GPIO Interface			
Note: The GPIO signals can be multiplexed via software and the JTAG_SEL pin to support other functions. See Table 22: "GPIO Alternative Signal Functions," on page 79 for additional details.			
B18	GPIO_0	I/O	Programmable GPIO pins.
B17	GPIO_1	I/O	
B4	GPIO_2	I/O	
E15	GPIO_3	I/O	
G2	GPIO_4	I/O	
A2	GPIO_5	I/O	
B3	GPIO_6	I/O	
N22	GPIO_7	I/O	
M22	GPIO_8	I/O	
K19	GPIO_9	I/O	
L22	GPIO_10	I/O	
J22	GPIO_11	I/O	
J19	GPIO_12	I/O	
K22	GPIO_13	I/O	
H22	GPIO_14	I/O	
H19	GPIO_15	I/O	

Table 18: Signal Descriptions (Cont.)

Ball#	Signal Name	Type	Description
JTAG Interface			
E14	JTAG_SEL	I/O	JTAG select. This pin must be connected to ground if the JTAG interface is not used. Note: See Table 22: “GPIO Alternative Signal Functions,” on page 79 for the JTAG signal pins.
Clocks			
E7	LPO_IN	I	External sleep clock input (32.768 kHz).
J5	BT_CLK_REQ	O	Asserts when WLAN wants the host to turn on the reference clock.
U23	WRF_XTAL_OUT	O	XTAL oscillator output.
V23	WRF_XTAL_IN	I	XTAL oscillator input.
Bluetooth Transceiver			
N1	BT_RF	O	Bluetooth RF input/output.
C2	BT_SF_CLK	I	SFLASH_CLK.
D2	BT_SF_CS_L	I/O	SFLASH_CSN.
F5	BT_SF_MISO	I/O	SFLASH master input, slave output.
H5	BT_SF_MOSI	I/O	SFLASH master output, slave input.
Bluetooth USB Interface			
B1	BT_USB_DN	I/O	USB (host) data negative. Negative terminal of the USB transceiver.
C1	BT_USB_DP	I/O	USB (host) data positive. Positive terminal of the USB transceiver.
Bluetooth UART			
E2	BT_UART_CTS_L	I	UART clear-to-send. Active-low clear-to-send signal for the HCI UART interface.
A16	BT_UART_RTS_L	O	UART request-to-send. Active-low request-to-send signal for the HCI UART interface. BT LED control pin.
E1	BT_UART_RXD	I	UART serial input. Serial data input for the HCI UART interface.
F2	BT_UART_TXD	O	UART serial output. Serial data output for the HCI UART interface.
Bluetooth I²S			
G1	BT_I2S_CLK	I/O	I ² S clock, can be master (output) or slave (input).
H8	BT_I2S_DO	I/O	I ² S data output.
H10	BT_I2S_DI	I/O	I ² S data input.
E5	BT_I2S_WS	I/O	I ² S WS, can be master (output) or slave (input).

Table 18: Signal Descriptions (Cont.)

Ball#	Signal Name	Type	Description
Bluetooth GPIO			
G5	BT_GPIO_4	I/O	Bluetooth general-purpose I/O.
Miscellaneous			
E18	WL_REG_ON	I	Used by PMU to power up or power down the internal BCM43569 regulators used by the WLAN section. Also, when deasserted, this pin holds the WLAN section in reset. This pin has an internal 200 kΩ pull-down resistor that is enabled by default. It can be disabled through programming.
H15	BT_REG_ON	I	Used by PMU to power up or power down the internal BCM43569 regulators used by the Bluetooth section. Also, when deasserted, this pin holds the Bluetooth section in reset. This pin has an internal 200 kΩ pull-down resistor that is enabled by default. It can be disabled through programming.
J1	BT_DEV_WAKE	I/O	Bluetooth DEV_WAKE.
J2	BT_HOST_WAKE	I/O	Bluetooth HOST_WAKE.
M5	BT_GPIO_2	I/O	Bluetooth HL mode.
N5	BT_GPIO_3	I/O	Bluetooth VSYNC_OUT.
P5	BT_GPIO_5	I/O	Bluetooth VSYN_IN.
Integrated Voltage Regulators			
B23	SR_VDDBATA5V	I	Quiet VBAT.
C22, C23	SR_VDDBATP5V	I	Power VBAT.
A20, A21	SR_VLX	O	CBUCK switching regulator output. Refer to Table 36 on page 103 for details of the inductor and capacitor required on this output.
D22, D23	LDO_VDD1P5	I	LNLDO input.
G22, G23	LDO_VDDBAT5V	I	LDO VBAT.
Y23	WRF_XTAL_VDD1P5	I	XTAL LDO input (1.35V).
W23	WRF_XTAL_VDD1P2	O	XTAL LDO output (1.2V).
J23	VOUT_LNLDO	O	Output of LNLDO.
A17	VOUT_CLDO	O	Output of core LDO.
H23	VOUT_BTLDO2P5	O	2.5V LDO. Connects to a 2.2 μF bypass capacitor to GND.
E22, E23	VOUT_LDO3P3_B	O	3.3V LDO.
F22, F23	VOUT_3P3	O	LDO 3.3V output.
F19	VOUT_3P3_SENSE	O	Voltage sense pin for LDO 3.3V output.

Table 18: Signal Descriptions (Cont.)

Ball#	Signal Name	Type	Description
Bluetooth Supplies			
P1	BT_PAVDD2P5	PWR	Bluetooth PA power supply.
L1	BT_LNAVDD1P2	PWR	Bluetooth LNA power supply.
K1	BT_IFVDD1P2	PWR	Bluetooth IF block power supply.
L2	BT_PLLVDD1P2	PWR	Bluetooth RF PLL power supply.
K2	BT_VCOVDD1P2	PWR	Bluetooth RF power supply.
M8	BT_VDDO	PWR	Core supply.
M10, N10	BT_VDDC	PWR	1.2V core supply for BT.
WLAN Supplies			
AC6	WRF_BUCK_VDD1P5_CORE0	PWR	Internal capacitor-less CORE0 LDO supply.
AA23	WRF_BUCK_VDD1P5_CORE1	PWR	Internal capacitor-less CORE1 LDO supply.
AC9	WRF_SYNTH_VBAT_VDD3P3	PWR	Synthesizer VDD 3.3V supply.
AA1	WRF_PADRV_VBAT_VDD3P3_CORE0	PWR	CORE0 PA Driver VBAT supply.
AC16	WRF_PADRV_VBAT_VDD3P3_CORE1	PWR	CORE1 PA Driver VBAT supply.
AB1	WRF_PA5G_VBAT_VDD3P3_CORE0	PWR	5 GHz CORE0 PA 3.3V VBAT supply.
AC17	WRF_PA5G_VBAT_VDD3P3_CORE1	PWR	5 GHz CORE1 PA 3.3V VBAT supply.
Y1	WRF_PA2G_VBAT_VDD3P3_CORE0	PWR	2 GHz CORE0 PA 3.3V VBAT supply.
AC15	WRF_PA2G_VBAT_VDD3P3_CORE1	PWR	2 GHz CORE1 PA 3.3V VBAT supply.
AC8	WRF_MMD_VDD1P2	PWR	1.2V supply.
AC7	WRF_PFD_VDD1P2	PWR	1.2V supply.
Miscellaneous Supplies			
E6	OTP_VDD33	PWR	OTP 3.3V supply.
K12, K14, L11, L14, L15, N15, P11, P12, P14, P15	VDDC	PWR	1.2V core supply for WLAN.
K16	VDDIO	PWR	1.8V–3.3V supply for WLAN. Must be directly connected to PMU_VDDIO on the PCB.
M10, N10	BT_VDDC	PWR	1.2V core supply for BT.
J16	VDDIO_PMU	PWR	1.8V–3.3V supply for PMU controls. Must be directly connected to VDDIO on the PCB.
L16	VDDIO_RF	PWR	IO supply for RF switch control pads (3.3V).
C5	USB2_AVDD3P3	PWR	3.3V supply for USB 2.0.
C8	USB2_AVDD1P2	PWR	1.2V supply for USB 2.0.
D12	USB3_PVDD1P2	PWR	1.2V supply for USB 3.0 PLL.

Table 18: Signal Descriptions (Cont.)

Ball#	Signal Name	Type	Description
E12	USB3_TRVDD1P2	PWR	1.2V supply for USB 3.0 TX/RX.
F12	USB3_DVDD1P2	PWR	1.2V supply for USB 3.0 I/O.
K10	AVDD_BBPLL	PWR	Baseband PLL supply.
Ground			
U22, V22, W22, Y22	WRF_XTAL_GND1P2	GND	XTAL ground.
V13	WRF_LOGENG_GND1P2	GND	LOGEN ground.
W13	WRF_VCO_GND1P2	GND	VCO ground.
W12	WRF_MMD_GND1P2	GND	Ground.
W11	WRF_CP_GND1P2	GND	Ground.
W10	WRF_PFD_GND1P2	GND	Ground.
A1, A18, A19, B2, E16, H12, H13, H16, J12, J14, P16, R11– R17, T13, T15, T16	VSSC	GND	Core ground for WLAN.
A22, A23	SR_PVSS	GND	Power ground.
E17	PMU_AVSS	GND	Quiet ground.
L9	AVSS_BBPLL	GND	Baseband PLL ground.
B7	USB2_AVSS	GND	USB2 ground.
A7	USB2_AVSSBG	GND	USB2 ground.
C11	USB3_TRGND	GND	USB 3.0 TX/RX ground.
C13	USB3_PGND	GND	USB 3.0 PLL ground.
T2, T5, T7, T10, U1, U2, U5, U13, U16, U17, V2, V5–V9, V16–V18, W1, W5, W6, W8, W15, W17, W18, Y2, AA2, AA22, AB2, AB4, AB5, AB7–AB11, AB13, AB15, AB16, AB18– AB23, AC1, AC3, AC5, AC10, AC12, AC14, AC18, AC19, AC21, AC23	RGND	GND	Ground.

Table 18: Signal Descriptions (Cont.)

Ball#	Signal Name	Type	Description
K5, K8, L8, M2, N8, P8, P10, R1, R2, R5, R7, R9	BTRGND	GND	Ground.
No-Connects			
C14, D13, D14	NC	I/O	No connect pins.

WLAN/BT GPIO Signals and Strapping Options

The pins listed in [Table 19](#) and [Table 20](#) are sampled at power-on reset (POR) to determine the various operating modes. Sampling occurs a few milliseconds after an internal POR or deassertion of the external POR. After the POR, each pin assumes the GPIO or alternative function specified in the signal descriptions table. Each strapping option pin has an internal pull-up (PU) or pull-down (PD) resistor that determines the default mode. To change the mode, connect an external PU resistor to VDDIO or a PD resistor to GND, using a 10 kΩ resistor or less.



Note: Refer to the reference board schematics for more information.

Table 19: WLAN GPIO Functions and Strapping Options

Pin Name	Default Function	Description
GPIO_4	0	1: SPROM is present 0: SPROM is absent (default). Applicable in PCIe Host mode.
GPIO_5	0	0: SFLASH absent (default) 1: SFLASH present
GPIO_[10, 9, 8]	[0,0,0]	Host interface selection: see Table 21 .
GPIO_12	1	1 = HTAvailable (default) 0 = ResourceModelnit is ALPAvailable. On PCBs, use a pull-down and tie to ALP clock mode. Only 0 mode is supported in the driver.

Table 20: BT GPIO Functions and Strapping Options

Pin Name	Default Function	Description
BT_GPIO4	0	1: BT serial flash is present. 0: BT serial flash is absent (default).

Table 21: GPIO_[10, 9, 8] Host Interface Selection

GPIO_[10, 9, 8] Bit Setting	WLAN Host Interface Mode	Bluetooth Mode
110	USB interface	BTUART or BTUSB; BT tPorts stand alone.

GPIO Alternative Signal Functions

Table 22: GPIO Alternative Signal Functions

Pin Names	Test Mode	UART	SFLASH	SPROM	BSC	Miscellaneous-0 (JTAG_SEL=1) GCI				Miscellaneous-1	Miscellaneous
						Function Select	6	7	8		
GPIO_0	0	2	3	4	5	6	7	8	9		
TEST_GPIO_0	UART_TX	-	-	-	BSC_CLK	-	GCI_GPIO_4	-	-		
GPIO_1	TEST_GPIO_1	UART_RX	-	-	BSC_SDA	RF_DISABLE_L	GCI_GPIO_5	-	-		
GPIO_2	TEST_GPIO_2	-	-	-	N/A	TCK	GCI_GPIO_1	-	-		
GPIO_3	TEST_GPIO_3	-	-	-	N/A	TMS	GCI_GPIO_0	-	-		
GPIO_6	TEST_GPIO_6	-	-	-	N/A	TRST_L	GCI_GPIO_2	-	-		
GPIO_7	TEST_GPIO_7	-	SFLASH_CS	SPROM_CS	BSC_SDA	PMU_TEST_O	GCI_GPIO_3	USB_MDC	-		
GPIO_8	TEST_GPIO_8	-	SFLASH_CLK	SPROM_CLK	BSC_CLK	-	-	USB_MDIO	--		
GPIO_9	TEST_GPIO_9	-	SFLASH_MI	SPROM_MI	PALDO_PU	-	-	PALDO_PD	-		
GPIO_10	TEST_GPIO_10	-	SFLASH_MO	SPROM_MO	-	-	-	-	-		
GPIO_11	TEST_GPIO_11	-	-	-	PALDO_PU	-	-	PALDO_PD	-		
GPIO_12	TEST_GPIO_12	-	-	-	-	-	-	-	-		
GPIO_13	TEST_GPIO_13	usbphy_scan_resetb	-	-	-	-	-	-	-		
GPIO_14	TEST_GPIO_14	WL_HOST_WAKE	-	-	-	-	-	-	-		
GPIO_15	TEST_GPIO_15	-	-	-	-	-	-	-	-		

Note:

- GPIO_14 is the WL_HOST_WAKE supported by the software driver.
- USB_VBUS_PRESENT indicates that USB30D is selected.
- SDIO_PADVDDIO=1 (not in straps table) is set to 3.3V by default for all packages.
- GPIO_13 supports WL_LED in FCBGA package.
- USB_MDx MDIO is the interface of USB1.0 and 2.0 PHY (depending on the strap option).

Broadcom[®]

January 19, 2016 • 43569-DS109-R

BROADCOM CONFIDENTIAL

I/O States

The following notations are used in [Table 23: "I/O States,"](#) on page 81:

- I: Input signal
- O: Output signal
- I/O: Input/Output signal
- PU = Pulled up
- PD = Pulled down
- NoPull = Neither pulled up nor pulled down
- Where applicable, the default value is shown in bold brackets, i.e., [**default value**]

Table 23: I/O States

Name	I/O	Keepers ^a	Active Mode	Low Power State/Sleep (All Power Present)	Power-down ^b (BT_REG_ON and WL_REG_ON Held Low)	Out-of-Reset; Before SW Download (BT_REG_ON High; WL_REG_ON High)	(WL_ and I_ and Pres)
WL_REG_ON	I	N	I: PD Pull-down can be disabled	I: PD Pull-down can be disabled	I: PD (of 200K)	I: PD (of 200K)	I: PD
BT_REG_ON							
BT_CLK_REQ	I/O	Y	Open drain or push-pull Programmable Active high	Open drain or push-pull Programmable Active high	High-Z, NoPull	Open drain Active high	Open Active
BT_HOST_WAKE	I/O	Y	I/O: PU, PD, NoPull Programmable	I/O: PU, PD, NoPull Programmable	High-Z, NoPull	I: PD	I: PD
BT_DEV_WAKE							
BT_GPIO 2, 3, 4, 5							
BT_UART_CTS_L	I	Y	I: NoPull	I: NoPull	High-Z, NoPull	I: PU	I: PU
BT_UART_RTS_L	O		O: NoPull	O: NoPull			
BT_UART_RXD	I		I: PU	I: NoPull			
BT_UART_TXD	O		O: NoPull	O: NoPull			
SDIO Data	I/O	N	I/O: PU (SDIO Mode)	I: PU (SDIO Mode)	High-Z, NoPull	I: PU (SDIO Mode)	I: PU (SDIO Mode)
SDIO CMD							
SDIO_CLK	I		I: NoPull	I: noPull		I: NoPull	I: NoPull
BT_PCM_CLK	I/O	Y	I: NoPull ^c	I: NoPull ^c	High-Z, NoPull	I: PD	I: PD
BT_PCM_IN							
BT_PCM_OUT							
BT_PCM_SYNC							
BT_I2S_WS							
BT_I2S_CLK							
BT_I2S_DI							
BT_I2S_DO							

Table 23: I/O States (Cont.)

Name	I/O	Keeper ^a	Active Mode	Low Power State/Sleep (All Power Present)	Power-down ^b (BT_REG_ON and WL_REG_ON Held Low)	Out-of-Reset; Before SW Download (BT_REG_ON High; WL_REG_ON High)	(WL and H and Pres
GPIO_0	I/O	Y	I/O: PU, PD, NoPull Programmable [NoPull]	I/O: PU, PD, NoPull Programmable [NoPull]	High-Z, NoPull	I: NoPull	I: NoP
GPIO_1		Y					
GPIO_2		Y					
GPIO_3		Y					
GPIO_4		Y	I/O: PU, PD, NoPull Programmable [PD]	I/O: PU, PD, NoPull Programmable [PD]		I: PD	I: PD
GPIO_5		Y	I/O: PU, PD, NoPull Programmable [PD]	I/O: PU, PD, NoPull Programmable [PD]			
GPIO_6		Y	I/O: PU, PD, NoPull Programmable [NoPull]	I/O: PU, PD, NoPull Programmable [NoPull]		I: NoPull	I: NoP
GPIO_7		Y					
GPIO_8		Y	I/O: PU, PD, NoPull	I/O: PU, PD, NoPull		I	I
GPIO_9		Y					
GPIO_10		Y	I/O: PU, PD, NoPull Programmable [PD]	I/O: PU, PD, NoPull Programmable [PD]		I: PD	I: PD
GPIO_11		Y	I/O: PU, PD, NoPull Programmable [NoPull]	I/O: PU, PD, NoPull Programmable [NoPull]		I: NoPull	I: NoP
GPIO_12		Y	I/O: PU, PD, NoPull Programmable [PU]	I/O: PU, PD, NoPull Programmable [PU]		I: PU	I: PU
GPIO_13		Y	I/O: PU, PD, NoPull	I/O: PU, PD, NoPull		I: NoPull	I: NoP
GPIO_14		Y					
GPIO_15		Y					
RF_SW_CTRL_X		Y	O: NoPull	O: NoPull		O: NoPull	O: NoP

- a. Keeper column: N = pad has no keeper. Y = pad has a keeper. Keeper is always active except in Power-down state. If there is no keeper and there is NoPull, then the pad should be driven to prevent leakage due to floating pad (SDIO_CLK, for example).
- b. In the Power-down state (xx_REG_ON=0): High-Z; NoPull => the pad is disabled because power is not supplied.
- c. Depending on whether the PCM interface is enabled and the configuration of PCM is in master or slave mode, it can be either input or output.
- d. Depending on whether the I²S interface is enabled and the configuration of I²S is in master or slave mode, it can be either input or output.

Section 12: DC Characteristics



Note: Values in this data sheet are design goals and are subject to change based on the results of device characterization.

Absolute Maximum Ratings



Caution! The absolute maximum ratings in [Table 24](#) indicate levels where permanent damage to the device can occur, even if these limits are exceeded for only a brief duration. Functional operation is not guaranteed under these conditions. Operation at absolute maximum conditions for extended periods can adversely affect long-term reliability of the device.

Table 24: Absolute Maximum Ratings

Rating	Symbol	Value	Unit
DC supply for VBAT ^a and PA driver supply ^b	VBAT	-0.5 to +6.0	V
DC supply voltage for digital I/O	VDDIO	-0.5 to 3.9	V
DC supply voltage for RF switch I/Os	VDDIO_RF	-0.5 to 3.9	V
DC input supply voltage for CLDO and LNLDO	–	-0.5 to 1.575	V
DC supply voltage for RF analog	VDDRF	-0.5 to 1.32	V
DC supply voltage for core	VDDC	-0.5 to 1.32	V
WRF_TCXO_VDD	–	-0.5 to 3.63	V
Maximum undershoot voltage for I/O ^c	V _{undershoot}	-0.5	V
Maximum overshoot voltage for I/O ^c	V _{overshoot}	VDDIO + 0.5	V
Maximum junction temperature	T _j	125	°C

- VBAT is the main power supply of the chip.
- The maximum continuous voltage is 5.25V. Voltage transients up to 6.0V for up to 10 seconds, cumulative duration over the lifetime of the device, are allowed. Voltage transients as high as 5.5V for up to 250 seconds, cumulative duration over the lifetime of the device, are allowed.
- Duration not to exceed 25% of the duty cycle.

Environmental Ratings

The environmental ratings are shown in [Table 25](#).

Table 25: Environmental Ratings

Characteristic	Value	Units	Conditions/Comments
Ambient temperature (T_A)	0 to +60	°C	Functional operation ^a
Storage temperature	-40 to +125	°C	–
Relative humidity	Less than 60	%	Storage
	Less than 85	%	Operation

- a. Functionality is guaranteed but specifications require derating at extreme temperatures; see the specification tables for details.

Recommended Operating Conditions and DC Characteristics



Caution! Functional operation is not guaranteed outside of the limits shown in Table 26, and operation outside these limits for extended periods can adversely affect long-term reliability of the device.

Table 26: Recommended Operating Conditions and DC Characteristics

Parameter	Symbol	Value			Unit
		Minimum	Typical	Maximum	
DC supply voltage for VBAT	VBAT ^a	3.0 ^b	–	3.6	V
DC supply voltage for core	VDD	1.14	1.2	1.26	V
DC supply voltage for RF blocks in chip	VDDRF	1.14	1.2	1.26	V
DC supply voltage for TCXO input buffer	WRF_TCXO_VDD	1.62	1.8	1.98	V
DC supply voltage for digital I/O	VDDIO, VDDIO_SD	1.71	–	3.63	V
DC supply voltage for RF switch I/Os	VDDIO_RF	3.0	3.3	3.6	V
External TSSI input	TSSI	0.15	–	0.95	V
Internal POR threshold	Vth_POR	0.4	–	0.7	V
Other Digital I/O Pins					
For VDDIO = 1.8V:					
Input high voltage	VIH	0.65 × VDDIO	–	–	V
Input low voltage	VIL	–	–	0.35 × VDDIO	V
Output high voltage @ 2 mA	VOH	VDDIO – 0.45	–	–	V
Output low voltage @ 2 mA	VOL	–	–	0.45	V
For VDDIO = 3.3V:					
Input high voltage	VIH	2.00	–	–	V
Input low voltage	VIL	–	–	0.80	V
Output high voltage @ 2 mA	VOH	VDDIO – 0.4	–	–	V
Output low Voltage @ 2 mA	VOL	–	–	0.40	V
RF Switch Control Output Pins^c					
For VDDIO_RF = 3.3V:					
Output high voltage @ 2 mA	VOH	VDDIO – 0.4	–	–	V
Output low voltage @ 2 mA	VOL	–	–	0.40	V
Input capacitance	C _{IN}	–	–	5	pF

a. VBAT is the main power supply of the chip

b. The BCM43569 is functional across this range of voltages. Optimal RF performance specified in the data sheet, however, is guaranteed only for 3.13V < VBAT < 3.6V.

c. Programmable 2 mA to 16 mA drive strength. Default is 10 mA.

Section 13: Bluetooth RF Specifications



Note: Values in this data sheet are design goals and are subject to change based on the results of device characterization.

Unless otherwise stated, limit values apply for the conditions specified in [Table 25: “Environmental Ratings,” on page 84](#) and [Table 26: “Recommended Operating Conditions and DC Characteristics,” on page 85](#). Typical values apply for an ambient temperature of +25°C.

Figure 26: RF Port Location for Bluetooth Testing

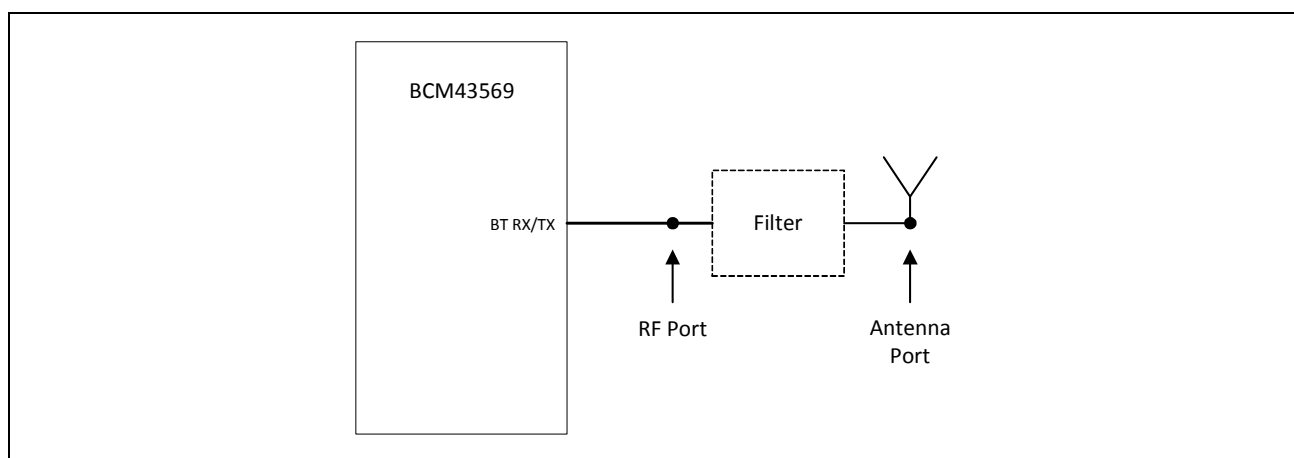

Note: All Bluetooth specifications are measured at the chip port unless otherwise specified.

Table 27: Bluetooth Receiver RF Specifications

Parameter	Conditions	Minimum	Typical	Maximum	Unit
Note: The specifications in this table are measured at the chip port output unless otherwise specified.					
General					
Frequency range	–	2402	–	2480	MHz
RX sensitivity	GFSK, 0.1% BER, 1 Mbps	–	–92	–	dBm
	$\pi/4$ -DQPSK, 0.01% BER, 2 Mbps	–	–94	–	dBm
	8-DPSK, 0.01% BER, 3 Mbps	–	–88	–	dBm
Minimum input IP3	–	–	–16	–	dBm
Maximum input at antenna	–	–	–20	–	dBm
RX LO Leakage					
2.4 GHz band	–	–	–93	–80.0	dBm
Interference Performance^a					
C/I co-channel	GFSK, 0.1% BER	–	8	11	dB
C/I 1 MHz adjacent channel	GFSK, 0.1% BER	–	–7	0	dB
C/I 2 MHz adjacent channel	GFSK, 0.1% BER	–	–38	–30	dB
C/I \geq 3 MHz adjacent channel	GFSK, 0.1% BER	–	–56	–40	dB
C/I image channel	GFSK, 0.1% BER	–	–31	–9	dB
C/I 1 MHz adjacent to image channel	GFSK, 0.1% BER	–	–46	–20	dB
C/I co-channel	$\pi/4$ -DQPSK, 0.1% BER	–	9	13	dB
C/I 1 MHz adjacent channel	$\pi/4$ -DQPSK, 0.1% BER	–	–11	0	dB
C/I 2 MHz adjacent channel	$\pi/4$ -DQPSK, 0.1% BER	–	–39	–30	dB
C/I \geq 3 MHz adjacent channel	$\pi/4$ -DQPSK, 0.1% BER	–	–55	–40	dB
C/I image channel	$\pi/4$ -DQPSK, 0.1% BER	–	–23	–7	dB
C/I 1 MHz adjacent to image channel	$\pi/4$ -DQPSK, 0.1% BER	–	–43	–20	dB
C/I co-channel	8-DPSK, 0.1% BER	–	17	21	dB
C/I 1 MHz adjacent channel	8-DPSK, 0.1% BER	–	–4	5	dB
C/I 2 MHz adjacent channel	8-DPSK, 0.1% BER	–	–37	–25	dB
C/I \geq 3 MHz adjacent channel	8-DPSK, 0.1% BER	–	–53	–33	dB
C/I Image channel	8-DPSK, 0.1% BER	–	–16	0	dB
C/I 1 MHz adjacent to image channel	8-DPSK, 0.1% BER	–	–37	–13	dB

a. The maximum value represents the actual Bluetooth specification required for Bluetooth qualification as defined in the version 4.1 specification.

Table 28: Bluetooth Transmitter RF Specifications

Parameter	Conditions	Minimum	Typical	Maximum	Unit
Note: The specifications in this table are measured at the Chip port output unless otherwise specified.					
General					
Frequency range		2402	–	2480	MHz
Basic rate (GFSK) TX power at Bluetooth		–	12.0	–	dBm
QPSK TX power at Bluetooth		–	9.0	–	dBm
8PSK TX power at Bluetooth		–	9.0	–	dBm
Power control step	–	–	4	8	dB
Note: Output power is with TCA and TSSI enabled.					
GFSK In-Band Spurious Emissions					
–20 dBc BW	–	–	0.93	1	MHz
EDR In-Band Spurious Emissions					
1.0 MHz < M – N < 1.5 MHz	M–N = the frequency range for which the spurious emission is measured relative to the transmit center frequency.	–	–38	–26.0	dBc
1.5 MHz < M – N < 2.5 MHz		–	–31	–20.0	dBm
M – N ≥ 2.5 MHz ^a		–	–43	–40.0	dBm
Out-of-Band Spurious Emissions					
30 MHz to 1 GHz	–	–	–	–36.0 ^{b, c}	dBm
1 GHz to 12.75 GHz	–	–	–	–30.0 ^{b, d, e}	dBm
1.8 GHz to 1.9 GHz	–	–	–	–47.0	dBm
5.15 GHz to 5.3 GHz	–	–	–	–47.0	dBm
GPS Band Spurious Emissions					
Spurious emissions	–	–	–103	–	dBm

a. The typical number is measured at ± 3 MHz offset.

b. The maximum value represents the value required for Bluetooth qualification as defined in the v4.1 specification.

c. The spurious emissions during Idle mode are the same as specified in [Table 28](#).

d. Specified at the Bluetooth Antenna port.

e. Meets this specification using a front-end band-pass filter.

Table 29: Local Oscillator Performance

Parameter	Minimum	Typical	Maximum	Unit
LO Performance				
Lock time	–	72	–	μs
Initial carrier frequency tolerance	–	±25	±75	kHz
Frequency Drift				
DH1 packet	–	±8	±25	kHz
DH3 packet	–	±8	±40	kHz
DH5 packet	–	±8	±40	kHz
Drift rate	–	5	20	kHz/50 μs
Frequency Deviation				
00001111 sequence in payload ^a	140	155	175	kHz
10101010 sequence in payload ^b	115	140	–	kHz
Channel spacing	–	1	–	MHz

a. This pattern represents an average deviation in payload.

b. Pattern represents the maximum deviation in payload for 99.9% of all frequency deviations.

Table 30: BLE RF Specifications

Parameter	Conditions	Minimum	Typical	Maximum	Unit
Frequency range	–	2402	–	2480	MHz
RX sense ^a	GFSK, 0.1% BER, 1 Mbps	–	–94	–	dBm
TX power ^b	–	–	8.5	–	dBm
Mod Char: delta F1 average	–	225	255	275	kHz
Mod Char: delta F2 max ^c	–	–	99.9	–	%
Mod Char: ratio	–	0.8	0.95	–	%

a. Dirty TX is on.

b. BLE TX power can be increased to compensate for front-end losses (such as BPF, diplexer, switch, etc.). The output is capped at 12 dBm out. The BLE TX power at the antenna port cannot exceed the 10 dBm specification limit.

c. At least 99.9% of all delta F2 max frequency values recorded over 10 packets must be greater than 185 kHz.

Section 14: WLAN RF Specifications

Introduction

The BCM43569 includes an integrated dual-band direct conversion radio that supports the 2.4 GHz and the 5 GHz bands. This section describes the RF characteristics of the 2.4 GHz and 5 GHz radios.

Note: Values in this section of the data sheet are design goals and are subject to change based on the results of device characterization.

Unless otherwise stated, limit values apply for the conditions specified in [Table 25: “Environmental Ratings,” on page 84](#) and [Table 26: “Recommended Operating Conditions and DC Characteristics,” on page 85](#). Typical values apply for an ambient temperature +25°C.

Figure 27: Port Locations (Applies to 2.4 GHz and 5 GHz)

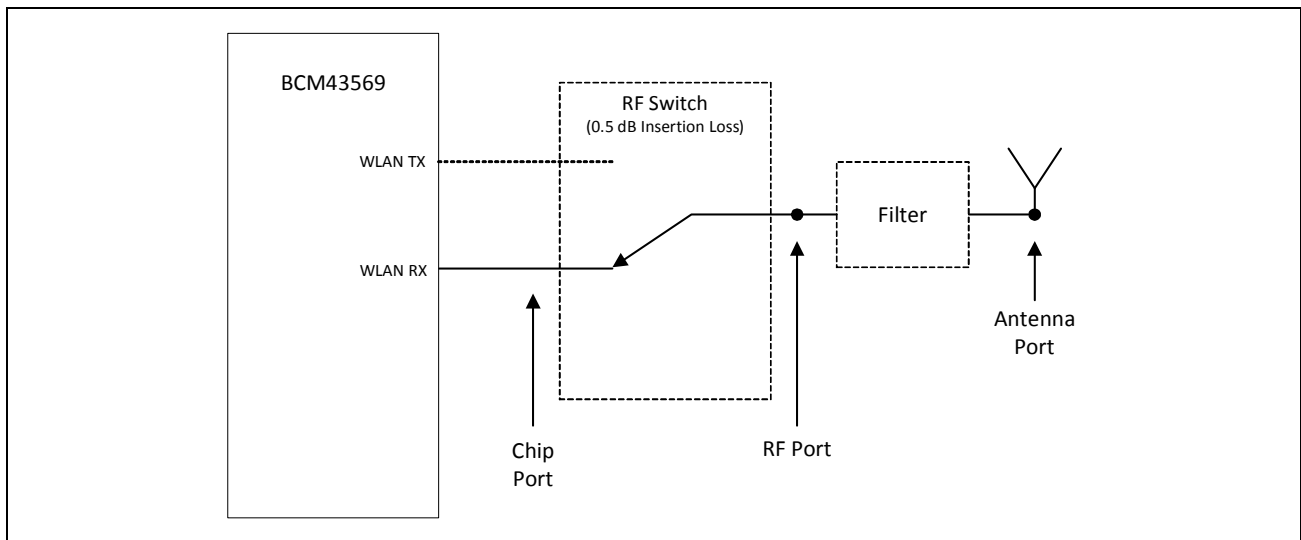

2.4 GHz Band General RF Specifications

Table 31: 2.4 GHz Band General RF Specifications

Item	Condition	Minimum	Typical	Maximum	Unit
TX/RX switch time	Including TX ramp down	–	–	5	μs
RX/TX switch time	Including TX ramp up	–	–	2	μs
Power-up and power-down ramp time	DSSS/CCK modulations	–	–	< 2	μs

WLAN 2.4 GHz Receiver Performance Specifications



Note: The specifications in [Table 32](#) are specified at the chip port unless otherwise specified. Results with FEMs that are not on the Broadcom AVL are not guaranteed.

Table 32: WLAN 2.4 GHz Receiver Performance Specifications

Parameter	Condition/Notes	Min.	Typ.	Maxi.	Unit
Frequency range	–	2400	–	2500	MHz
RX sensitivity IEEE 802.11b ^a	1 Mbps DSSS	–	–98.5	–	dBm
	2 Mbps DSSS	–	–95.4	–	dBm
	5.5 Mbps DSSS	–	–93.4	–	dBm
	11 Mbps DSSS	–	–90.4	–	dBm
SISO RX sensitivity IEEE 802.11g (10% PER for 1024 octet PSDU) ^a	6 Mbps OFDM	–	–94.4	–	dBm
	9 Mbps OFDM	–	–93.4	–	dBm
	12 Mbps OFDM	–	–91.5	–	dBm
	18 Mbps OFDM	–	–89.3	–	dBm
	24 Mbps OFDM	–	–86.0	–	dBm
	36 Mbps OFDM	–	–82.8	–	dBm
	48 Mbps OFDM	–	–78.4	–	dBm
	54 Mbps OFDM	–	–77.0	–	dBm
MIMO RX sensitivity IEEE 802.11g (10% PER for 1024 octet PSDU) ^a	6 Mbps OFDM	–	–95.6	–	dBm/core
	9 Mbps OFDM	–	–95.4	–	dBm/core
	12 Mbps OFDM	–	–94.3	–	dBm/core
	18 Mbps OFDM	–	–92.4	–	dBm/core
	24 Mbps OFDM	–	–88.9	–	dBm/core
	36 Mbps OFDM	–	–85.8	–	dBm/core
	48 Mbps OFDM	–	–81.4	–	dBm/core
	54 Mbps OFDM	–	–80.0	–	dBm/core
SISO RX sensitivity IEEE 802.11n (10% PER for 4096 octet PSDU) ^{a, b} Defined for default parameters: GT, 800 ns GI, LDPC coding, and non-STBC.	20 MHz channel spacing for all MCS rates				
	MCS0	–	–93.6	–	dBm
	MCS1	–	–91.0	–	dBm
	MCS2	–	–88.7	–	dBm
	MCS3	–	–86.2	–	dBm
	MCS4	–	–82.7	–	dBm
	MCS5	–	–78.6	–	dBm
	MCS6	–	–77.2	–	dBm
MCS7	–	–75.4	–	dBm	

Table 32: WLAN 2.4 GHz Receiver Performance Specifications (Cont.)

Parameter	Condition/Notes	Min.	Typ.	Maxi.	Unit
MIMO RX sensitivity IEEE 802.11n (10% PER for 4096 octet PSDU) ^{a, b} Defined for default parameters: GT, 800 ns GI, LDPC coding, and non-STBC.	20 MHz channel spacing for all MCS rates				
	MCS0	–	–94.8	–	dBm/core
	MCS1	–	–93.7	–	dBm/core
	MCS2	–	–91.6	–	dBm/core
	MCS3	–	–88.9	–	dBm/core
	MCS4	–	–85.6	–	dBm/core
	MCS5	–	–81.5	–	dBm/core
	MCS6	–	–80.3	–	dBm/core
	MCS7	–	–78.4	–	dBm/core
	MCS8	–	–94.5	–	dBm/core
MCS15	–	–76.2	–	dBm/core	
SISO RX sensitivity IEEE 802.11n (10% PER for 4096 octet PSDU) ^{a, b} Defined for default parameters: GT, 800 ns GI, LDPC coding, and non-STBC.	40 MHz channel spacing for all MCS rates				
	MCS0	–	–91.1	–	dBm
	MCS1	–	–88.5	–	dBm
	MCS2	–	–86.0	–	dBm
	MCS3	–	–83.5	–	dBm
	MCS4	–	–80.1	–	dBm
	MCS5	–	–76.3	–	dBm
	MCS6	–	–74.4	–	dBm
MCS7	–	–73.1	–	dBm	
MIMO RX sensitivity IEEE 802.11n (10% PER for 4096 octet PSDU) ^{a, b} Defined for default parameters: GT, 800 ns GI, LDPC coding, and non-STBC.	40 MHz channel spacing for all MCS rates				
	MCS0	–	–93.3	–	dBm/core
	MCS1	–	–91.3	–	dBm/core
	MCS2	–	–88.9	–	dBm/core
	MCS3	–	–86.2	–	dBm/core
	MCS4	–	–83.2	–	dBm/core
	MCS5	–	–79.2	–	dBm/core
	MCS6	–	–77.4	–	dBm/core
	MCS7	–	–76.5	–	dBm/core
	MCS8	–	–91.7	–	dBm/core
MCS15	–	–73.4	–	dBm/core	

Table 32: WLAN 2.4 GHz Receiver Performance Specifications (Cont.)

Parameter	Condition/Notes	Min.	Typ.	Maxi.	Unit
SISO RX sensitivity IEEE 802.11ac (10% PER for 4096 octet PSDU) ^{a, b} Defined for default parameters: 800 ns GI and non-STBC	20 MHz channel spacing for all MCS rates				
	MCS0, Nss 1	–	–93.8	–	dBm
	MCS1, Nss 1	–	–91.1	–	dBm
	MCS2, Nss 1	–	–89.9	–	dBm
	MCS3, Nss 1	–	–87.4	–	dBm
	MCS4, Nss 1	–	–83.6	–	dBm
	MCS5, Nss 1	–	–79.8	–	dBm
	MCS6, Nss 1	–	–78.4	–	dBm
	MCS7, Nss 1	–	–77.1	–	dBm
	MCS8, Nss 1	–	–72.9	–	dBm
MCS9, Nss 1	–	–71.4	–	dBm	
MIMO RX sensitivity IEEE 802.11ac (10% PER for 4096 octet PSDU) ^{a, b} Defined for default parameters: 800 ns GI and non-STBC	20 MHz channel spacing for all MCS rates				
	MCS0, Nss 1	–	–95.6	–	dBm/core
	MCS1, Nss 1	–	–93.9	–	dBm/core
	MCS2, Nss 1	–	–92.6	–	dBm/core
	MCS3, Nss 1	–	–90.3	–	dBm/core
	MCS4, Nss 1	–	–87.0	–	dBm/core
	MCS5, Nss 1	–	–82.7	–	dBm/core
	MCS6, Nss 1	–	–81.3	–	dBm/core
	MCS7, Nss 1	–	–80.2	–	dBm/core
	MCS8, Nss 1	–	–76.3	–	dBm/core
	MCS9, Nss 1	–	–74.5	–	dBm/core
MCS9, Nss 2	–	–71.1	–	dBm/core	
SISO RX sensitivity IEEE 802.11ac (10% PER for 4096 octet PSDU) ^{a, b} Defined for default parameters: 800 ns GI and non-STBC.	40 MHz channel spacing for all MCS rates				
	MCS0, Nss 1	–	–91.5	–	dBm
	MCS1, Nss 1	–	–88.5	–	dBm
	MCS2, Nss 1	–	–87.1	–	dBm
	MCS3, Nss 1	–	–84.7	–	dBm
	MCS4, Nss 1	–	–81.4	–	dBm
	MCS5, Nss 1	–	–77.2	–	dBm
	MCS6, Nss 1	–	–75.8	–	dBm
	MCS7, Nss 1	–	–74.4	–	dBm
	MCS8, Nss 1	–	–70.4	–	dBm
MCS9, Nss 1	–	–68.7	–	dBm	

Table 32: WLAN 2.4 GHz Receiver Performance Specifications (Cont.)

Parameter	Condition/Notes	Min.	Typ.	Maxi.	Unit
MIMO RX sensitivity IEEE 802.11ac (10% PER for 4096 octet PSDU) ^{a, b} Defined for default parameters: 800 ns GI and non-STBC.	40 MHz channel spacing for all MCS rates				
	MCS0, Nss 1	–	–93.1	–	dBm/core
	MCS1, Nss 1	–	–91.3	–	dBm/core
	MCS2, Nss 1	–	–89.7	–	dBm/core
	MCS3, Nss 1	–	–87.8	–	dBm/core
	MCS4, Nss 1	–	–84.3	–	dBm/core
	MCS5, Nss 1	–	–80.2	–	dBm/core
	MCS6, Nss 1	–	–78.6	–	dBm/core
	MCS7, Nss 1	–	–77.3	–	dBm/core
	MCS8, Nss 1	–	–73.6	–	dBm/core
	MCS9, Nss 1	–	–71.6	–	dBm/core
	MCS0, Nss 2	–	–91.7	–	dBm/core
MCS9, Nss 2	–	–67.7	–	dBm/core	
In-band static CW jammer immunity ($f_c - 8 \text{ MHz} < f_{cw} < + 8 \text{ MHz}$)	RX PER < 1%, 54 Mbps OFDM, 1000 octet PSDU for: ($RxSens + 23 \text{ dB} < Rxlevel < \text{max input level}$)	–80	–	–	dBm
Input in-band IP3	Maximum LNA gain	–	–15.5	–	dBm
	Minimum LNA gain	–	–1.5	–	dBm
Maximum receive level @ 2.4 GHz	@ 1, 2 Mbps (8% PER, 1024 octets)	–	–3.5	–	dBm
	@ 5.5, 11 Mbps (8% PER, 1024 octets)	–	–9.5	–	dBm
	@ 6–54 Mbps (10% PER, 1024 octets)	–	–9.5	–	dBm
	@ MCS0–MCS7 rates (10% PER, 4095 octets)	–	–9.5	–	dBm
	@ MCS8–MCS9 rates (10% PER, 4095 octets)	–	–11.5	–	dBm
LPF 3 dB bandwidth	–	9	–	36	MHz
Adjacent channel rejection-DSSS (Difference between interfering and desired signal at 8% PER for 1024 octet PSDU with desired signal level as specified in Condition/Notes)	Desired and interfering signal 30 MHz apart				
	1 Mbps DSSS –74 dBm	35	–	–	dB
	2 Mbps DSSS –74 dBm	35	–	–	dB
	Desired and interfering signal 25 MHz apart				
	5.5 Mbps DSSS –70 dBm	35	–	–	dB
11 Mbps DSSS –70 dBm	35	–	–	dB	

Table 32: WLAN 2.4 GHz Receiver Performance Specifications (Cont.)

Parameter	Condition/Notes	Min.	Typ.	Maxi.	Unit	
Adjacent channel rejection-OFDM (difference between interfering and desired signal (25 MHz apart) at 10% PER for 1024 octet PSDU with desired signal level as specified in Condition/Notes)	6 Mbps OFDM	-79 dBm	16	-	-	dB
	9 Mbps OFDM	-78 dBm	15	-	-	dB
	12 Mbps OFDM	-76 dBm	13	-	-	dB
	18 Mbps OFDM	-74 dBm	11	-	-	dB
	24 Mbps OFDM	-71 dBm	8	-	-	dB
	36 Mbps OFDM	-67 dBm	4	-	-	dB
	48 Mbps OFDM	-63 dBm	0	-	-	dB
	54 Mbps OFDM	-62 dBm	-1	-	-	dB
Adjacent channel rejection MCS0-9 (Difference between interfering and desired signal (25 MHz apart) at 10% PER for 4096 octet PSDU with desired signal level as specified in Condition/Notes)	MCS0	-79 dBm	16	-	-	dB
	MCS1	-76 dBm	13	-	-	dB
	MCS2	-74 dBm	11	-	-	dB
	MCS3	-71 dBm	8	-	-	dB
	MCS4	-67 dBm	4	-	-	dB
	MCS5	-63 dBm	0	-	-	dB
	MCS6	-62 dBm	-1	-	-	dB
	MCS7	-61 dBm	-2	-	-	dB
	MCS8	-59 dBm	-4	-	-	dB
	MCS9	-57 dBm	-6	-	-	dB
Maximum receiver gain	-	-	-	95	-	dB
Gain control step	-	-	-	3	-	dB
RSSI accuracy ^c	Range -90 dBm to -30 dBm	-5	-	5	-	dB
	Range above -30 dBm	-8	-	8	-	dB
Return loss	Zo = 50Ω, across the dynamic range	10	11.5	13	-	dB
Receiver cascaded noise figure	At maximum gain	-	4.5	-	-	dB

- Derate by 1.5 dB over the operating temperature range and for voltages from 3.0V to 3.13V.
- Sensitivity degradations for alternate settings in MCS modes. MM: 0.5 dB drop, and SGI: 2 dB drop.
- The minimum and maximum values shown have a 95% confidence level.

WLAN 2.4 GHz Transmitter Performance Specifications



Note: The specifications in [Table 33](#) are specified at the chip port unless otherwise specified. Results with FEMs that are not on the Broadcom AVL are not guaranteed.

Table 33: WLAN 2.4 GHz Transmitter Performance Specifications

Parameter	Condition/Notes	Maximum			Unit	
		Minimum	Typical	m		
Frequency range	–	2400	–	2500	MHz	
EVM Does Not Exceed						
TX power at RF port for highest power level setting at 25°C with spectral mask and EVM compliance ^a	802.11b (DSSS/CCK)	–9 dB	18.5	20	–	dBm
	OFDM, BPSK	–8 dB	18	19	–	dBm
	OFDM, QPSK	–13 dB	18	19	–	dBm
	OFDM, 16-QAM	–19 dB	16.5	18	–	dBm
	OFDM, 64-QAM (R = 3/4)	–25 dB	16.5	18	–	dBm
	OFDM, 64-QAM (R = 5/6)	–28 dB	16.5	18	–	dBm
	OFDM, 256-QAM (R = 3/4)	–30 dB	15.5	17	–	dBm
	OFDM, 256-QAM (R = 5/6)	–32 dB	14.5	16	–	dBm
Phase noise	40 MHz crystal, integrated from 10 kHz to 10 MHz	–	0.45	–	–	Degrees
TX power control dynamic range	–	10	–	–	–	dB
Closed-loop TX power variation at highest power level setting	Across full temperature and voltage range. Applies across 10 dBm to 20 dBm output power range.	–	–	±1.5	–	dB
Carrier suppression	–	15	–	–	–	dBc
Gain control step	–	–	0.25	–	–	dB
Return loss at chip port TX	Z _o = 50Ω	–	6	–	–	dB

a. Derate by 1.5 dB over the operating temperature range and for voltages from 3.0V to 3.13V.

WLAN 5 GHz Receiver Performance Specifications



Note: The specifications in [Table 34](#) are specified at the chip port unless otherwise specified. Results with FEMs that are not on the Broadcom AVL are not guaranteed.

Table 34: WLAN 5 GHz Receiver Performance Specifications

Parameter	Condition/Notes	Minimum	Typical	Maximum	Unit
Frequency range	–	4900	–	5845	MHz
SISO RX sensitivity IEEE 802.11a (10% PER for 1000 octet PSDU) ^a	6 Mbps OFDM	–	–94.5	–	dBm
	9 Mbps OFDM	–	–93.2	–	dBm
	12 Mbps OFDM	–	–91.3	–	dBm
	18 Mbps OFDM	–	–89.1	–	dBm
	24 Mbps OFDM	–	–85.7	–	dBm
	36 Mbps OFDM	–	–82.4	–	dBm
	48 Mbps OFDM	–	–78.0	–	dBm
	54 Mbps OFDM	–	–76.6	–	dBm
MIMO RX sensitivity IEEE 802.11a (10% PER for 1024 octet PSDU) ^a	6 Mbps OFDM	–	–95.7	–	dBm/core
	9 Mbps OFDM	–	–95.6	–	dBm/core
	12 Mbps OFDM	–	–94.1	–	dBm/core
	18 Mbps OFDM	–	–92.1	–	dBm/core
	24 Mbps OFDM	–	–89.0	–	dBm/core
	36 Mbps OFDM	–	–85.7	–	dBm/core
	48 Mbps OFDM	–	–81.2	–	dBm/core
	54 Mbps OFDM	–	–79.9	–	dBm/core
SISO RX sensitivity IEEE 802.11n (10% PER for 4096 octet PSDU) ^a Defined for default parameters: GF, 800 ns GI, LDPC coding, and non-STBC.	20 MHz channel spacing for all MCS rates				
	MCS0	–	–93.3	–	dBm
	MCS1	–	–90.9	–	dBm
	MCS2	–	–88.7	–	dBm
	MCS3	–	–86.1	–	dBm
	MCS4	–	–82.5	–	dBm
	MCS5	–	–78.4	–	dBm
	MCS6	–	–76.9	–	dBm
MCS7	–	–75.1	–	dBm	

Table 34: WLAN 5 GHz Receiver Performance Specifications (Cont.)

Parameter	Condition/Notes	Minimum	Typical	Maximum	Unit
MIMO RX sensitivity IEEE 802.11n (10% PER for 4096 octet PSDU) ^a Defined for default parameters: GF, 800 ns GI, LDPC coding, and non-STBC.	20 MHz channel spacing for all MCS rates				
	MCS0	–	–95.8	–	dBm/core
	MCS1	–	–93.8	–	dBm/core
	MCS2	–	–91.4	–	dBm/core
	MCS3	–	–88.7	–	dBm/core
	MCS4	–	–85.6	–	dBm/core
	MCS5	–	–81.4	–	dBm/core
	MCS6	–	–79.8	–	dBm/core
	MCS7	–	–78.3	–	dBm/core
	MCS8	–	–75.6	–	dBm/core
SISO RX sensitivity IEEE 802.11n (10% PER for 4096 octet PSDU) ^a Defined for default parameters: GF, 800 ns GI, LDPC coding, and non-STBC.	40 MHz channel spacing for all MCS rates				
	MCS0	–	–91.1	–	dBm
	MCS1	–	–88.5	–	dBm
	MCS2	–	–86.0	–	dBm
	MCS3	–	–83.5	–	dBm
	MCS4	–	–80.1	–	dBm
	MCS5	–	–76.3	–	dBm
	MCS6	–	–74.3	–	dBm
MIMO RX sensitivity IEEE 802.11n (10% PER for 4096 octet PSDU) ^a Defined for default parameters: GF, 800 ns GI, LDPC coding, and non-STBC.	40 MHz channel spacing for all MCS rates				
	MCS0	–	–92.9	–	dBm/core
	MCS1	–	–91.1	–	dBm/core
	MCS2	–	–88.7	–	dBm/core
	MCS3	–	–86.2	–	dBm/core
	MCS4	–	–83.0	–	dBm/core
	MCS5	–	–79.2	–	dBm/core
	MCS6	–	–77.4	–	dBm/core
	MCS7	–	–76.4	–	dBm/core
	MCS8	–	–91.9	–	dBm/core
MCS15	–	–73.3	–	dBm/core	

Table 34: WLAN 5 GHz Receiver Performance Specifications (Cont.)

Parameter	Condition/Notes	Minimum	Typical	Maximum	Unit
SISO RX sensitivity IEEE 802.11ac (10% PER for 4096 octet PSDU) ^a Defined for default parameters: 800 ns GI, LDPC coding, and non-STBC.	20 MHz channel spacing for all MCS rates				
	MCS0, Nss 1	–	–93.4	–	dBm
	MCS1, Nss 1	–	–91.0	–	dBm
	MCS2, Nss 1	–	–89.7	–	dBm
	MCS3, Nss 1	–	–87.2	–	dBm
	MCS4, Nss 1	–	–83.1	–	dBm
	MCS5, Nss 1	–	–79.5	–	dBm
	MCS6, Nss 1	–	–78.0	–	dBm
	MCS7, Nss 1	–	–76.8	–	dBm
	MCS8, Nss 1	–	–72.3	–	dBm
MCS9, Nss 1	–	–70.7	–	dBm	
MIMO RX sensitivity IEEE 802.11ac (10% PER for 4096 octet PSDU) ^a Defined for default parameters: 800 ns GI, LDPC coding, and non-STBC.	20 MHz channel spacing for all MCS rates				
	MCS0, Nss 1	–	–95.7	–	dBm/core
	MCS1, Nss 1	–	–93.9	–	dBm/core
	MCS2, Nss 1	–	–92.7	–	dBm/core
	MCS3, Nss 1	–	–90.3	–	dBm/core
	MCS4, Nss 1	–	–86.8	–	dBm/core
	MCS5, Nss 1	–	–82.7	–	dBm/core
	MCS6, Nss 1	–	–81.4	–	dBm/core
	MCS7, Nss 1	–	–79.9	–	dBm/core
	MCS8, Nss 1	–	–75.6	–	dBm/core
	MCS0, Nss 2	–	–91	–	dBm/core
	MCS8, Nss 2	–	–67.1	–	dBm/core
MCS9, Nss 2	–	–74.1	–	dBm/core	
SISO RX sensitivity IEEE 802.11ac (10% PER for 4096 octet PSDU) ^a Defined for default parameters: 800 ns GI, LDPC coding, and non-STBC.	40 MHz channel spacing for all MCS rates				
	MCS0, Nss 1	–	–91.5	–	dBm
	MCS1, Nss 1	–	–88.5	–	dBm
	MCS2, Nss 1	–	–87.2	–	dBm
	MCS3, Nss 1	–	–84.6	–	dBm
	MCS4, Nss 1	–	–81.2	–	dBm
	MCS5, Nss 1	–	–77.1	–	dBm
	MCS6, Nss 1	–	–75.6	–	dBm
	MCS7, Nss 1	–	–74.2	–	dBm
	MCS8, Nss 1	–	–70.0	–	dBm
MCS9, Nss 1	–	–68.2	–	dBm	

Table 34: WLAN 5 GHz Receiver Performance Specifications (Cont.)

Parameter	Condition/Notes	Minimum	Typical	Maximum	Unit
MIMO RX sensitivity IEEE 802.11ac (10% PER for 4096 octet PSDU) ^a Defined for default parameters: 800 ns GI, LDPC coding, and non-STBC.	40 MHz channel spacing for all MCS rates				
	MCS0, Nss 1	–	–93.0	–	dBm/core
	MCS1, Nss 1	–	–91.2	–	dBm/core
	MCS2, Nss 1	–	–89.8	–	dBm/core
	MCS3, Nss 1	–	–87.6	–	dBm/core
	MCS4, Nss 1	–	–84.1	–	dBm/core
	MCS5, Nss 1	–	–80.1	–	dBm/core
	MCS6, Nss 1	–	–78.6	–	dBm/core
	MCS7, Nss 1	–	–77.3	–	dBm/core
	MCS8, Nss 1	–	–73.1	–	dBm/core
	MCS9, Nss 1	–	–71.4	–	dBm/core
	MCS0, Nss 2	–	–91.8	–	dBm/core
MCS9, Nss 2	–	–67.1	–	dBm/core	
SISO RX sensitivity IEEE 802.11ac (10% PER for 4096 octet PSDU) ^a Defined for default parameters: 800 ns GI, LDPC coding, and non-STBC.	80 MHz channel spacing for all MCS rates				
	MCS0, Nss 1	–	–88.7	–	dBm
	MCS1, Nss 1	–	–85.2	–	dBm
	MCS2, Nss 1	–	–83.8	–	dBm
	MCS3, Nss 1	–	–81.2	–	dBm
	MCS4, Nss 1	–	–77.8	–	dBm
	MCS5, Nss 1	–	–73.5	–	dBm
	MCS6, Nss 1	–	–72.2	–	dBm
	MCS7, Nss 1	–	–70.5	–	dBm
	MCS8, Nss 1	–	–66.4	–	dBm
MCS9, Nss 1	–	–64.1	–	dBm	
MIMO RX sensitivity IEEE 802.11ac (10% PER for 4096 octet PSDU) ^a Defined for default parameters: 800 ns GI, LDPC coding, and non-STBC.	80 MHz channel spacing for all MCS rates				
	MCS0, Nss 1	–	–90.2	–	dBm/core
	MCS1, Nss 1	–	–88.0	–	dBm/core
	MCS2, Nss 1	–	–86.5	–	dBm/core
	MCS3, Nss 1	–	–84.2	–	dBm/core
	MCS4, Nss 1	–	–80.7	–	dBm/core
	MCS5, Nss 1	–	–76.6	–	dBm/core
	MCS6, Nss 1	–	–75.0	–	dBm/core
	MCS7, Nss 1	–	–73.4	–	dBm/core
	MCS8, Nss 1	–	–69.4	–	dBm/core
	MCS9, Nss 1	–	–67.2	–	dBm/core
	MCS0, Nss 2	–	–88.2	–	dBm/core
MCS9, Nss 2	–	–62.2	–	dBm/core	
Input in-band IP3	Maximum LNA gain	–	–15.5	–	dBm
	Minimum LNA gain	–	–1.5	–	dBm

Table 34: WLAN 5 GHz Receiver Performance Specifications (Cont.)

Parameter	Condition/Notes	Minimum	Typical	Maximum	Unit
Maximum receive level @ 5.24 GHz	@ 6, 9, 12 Mbps	–	–9.5	–	dBm
	@ 18, 24, 36, 48, 54 Mbps	–	–14.5	–	dBm
LPF 3 dB bandwidth	–	9	–	36	MHz
Adjacent channel rejection (Difference between interfering and desired signal (20 MHz apart) at 10% PER for 1000 octet PSDU with desired signal level as specified in Condition/Notes)	6 Mbps OFDM	–79 dBm	16	–	dB
	9 Mbps OFDM	–78 dBm	15	–	dB
	12 Mbps OFDM	–76 dBm	13	–	dB
	18 Mbps OFDM	–74 dBm	11	–	dB
	24 Mbps OFDM	–71 dBm	8	–	dB
	36 Mbps OFDM	–67 dBm	4	–	dB
	48 Mbps OFDM	–63 dBm	0	–	dB
	54 Mbps OFDM	–62 dBm	–1	–	dB
	65 Mbps OFDM	–61 dBm	–2	–	dB
	(Difference between interfering and desired signal (40 MHz apart) at 10% PER for 1000 ^b octet PSDU with desired signal level as specified in Condition/Notes)	6 Mbps OFDM	–78.5 dBm	32	–
9 Mbps OFDM		–77.5 dBm	31	–	dB
12 Mbps OFDM		–75.5 dBm	29	–	dB
18 Mbps OFDM		–73.5 dBm	27	–	dB
24 Mbps OFDM		–70.5 dBm	24	–	dB
36 Mbps OFDM		–66.5 dBm	20	–	dB
48 Mbps OFDM		–62.5 dBm	16	–	dB
54 Mbps OFDM	–61.5 dBm	15	–	dB	
65 Mbps OFDM	–60.5 dBm	14	–	dB	
Maximum receiver gain	–	–	95	–	dB
Gain control step	–	–	3	–	dB
RSSI accuracy ^c	Range –90 dBm to –30 dBm	–5	–	5	dB
	Range above –30 dBm	–8	–	8	dB
Return loss	Zo = 50Ω, across the dynamic range	10	–	13	dB
Receiver cascaded noise figure	At maximum gain	–	5	–	dB

- Derate by 1.5 dB over the operating temperature range and for voltages from 3.0V to 3.13V.
- For 65 Mbps, the size is 4096.
- The minimum and maximum values shown have a 95% confidence level.

WLAN 5 GHz Transmitter Performance Specifications



Note: The specifications in [Table 35](#) are specified at the chip port unless otherwise specified. Results with FEMs that are not on the Broadcom AVL are not guaranteed.

Table 35: WLAN 5 GHz Transmitter Performance Specifications

Parameter	Condition/Notes	Minimum	Typical	Maximum	Unit	
Frequency range	–	4900	–	5845	MHz	
TX power at RF port for highest power level setting at 25°C with spectral mask and EVM compliance ^a	OFDM, QPSK	–13 dB	17.5	18.5	–	dBm
	OFDM, 16-QAM	–19 dB	16	17.5	–	dBm
	OFDM, 64-QAM (R = 3/4)	–25 dB	16	17.5	–	dBm
	OFDM, 64-QAM (R = 5/6)	–28 dB	16	17.5	–	dBm
	OFDM, 256-QAM (R = 3/4, VHT)	–30 dB	14	15.5	–	dBm
	OFDM, 256-QAM (R = 5/6, VHT)	–32 dB	13	14.5	–	dBm
Phase noise	40 MHz crystal, integrated from 10 kHz to 10 MHz	–	0.5	–	Degrees	
TX power control dynamic range	–	10	–	–	dB	
Closed loop TX power variation at highest power level setting	Across full-temperature and voltage range. Applies across 10 to 20 dBm output power range.	–	–	±2.0	dB	
Carrier suppression	–	15	–	–	dBc	
Gain control step	–	–	0.25	–	dB	
Return loss	Z _o = 50Ω	–	6	–	dB	

a. Derate by 1.5 dB over the operating temperature range and for voltages from 3.0V to 3.13V.

Section 15: Internal Regulator Electrical Specifications



Note: Values in this data sheet are design goals and are subject to change based on the results of device characterization.

Functional operation is not guaranteed outside of the specification limits provided in this section.

Core Buck Switching Regulator

Table 36: Core Buck Switching Regulator (CBUCK) Specifications

Specification	Notes	Minimum	Typical	Maximum	Units
Input supply voltage (DC)	DC voltage range inclusive of disturbances.	3.0	3.3	3.6	V
PWM mode switching frequency	CCM, Load > 100 mA VBAT ^a = 3.6V	2.8	4	5.2	MHz
PWM output current	–	–	–	600	mA
Output current limit	–	–	1400	–	mA
Output voltage range	Programmable, 30 mV steps Default = 1.35V	1.2	1.35	1.5	V
PWM output voltage DC accuracy	Includes load and line regulation. Forced PWM mode	–4	–	4	%
PWM ripple voltage, static	Measure with 20 MHz bandwidth limit. Static Load. Max Ripple based on VBAT = 3.6V, Vout = 1.35V, Fsw = 4 MHz, 2.2 μH inductor L > 1.05 μH, Cap + Board total-ESR < 20 mΩ, C _{out} > 1.9 μF, ESL < 200 pH	–	7	20	mVpp
PWM mode peak efficiency	Peak Efficiency at 200 mA load	78	86	–	%
PFM mode efficiency	10 mA load current	70	81	–	%
Start-up time from power down	VBAT and VIO already ON and steady. Time from REG_ON rising edge to CLDO reaching 1.2V	–	–	850	μs
External inductor	0806 size, ± 30%, 0.11 ± 25% Ohms	–	2.2	–	μH
External output capacitor	Ceramic, X5R, 0402, ESR < 30 mΩ at 4 MHz, ± 20%, 6.3V	2.0 ^b	4.7	10 ^c	μF
External input capacitor	For SR_VDDBATP5V pin, ceramic, X5R, 0603, ESR < 30 mΩ at 4 MHz, ± 20%, 6.3V, 4.7 μF	0.67 ^b	4.7	–	μF

Table 36: Core Buck Switching Regulator (CBUCK) Specifications (Cont.)

Specification	Notes	Minimum	Typical	Maximum	Units
Input supply voltage ramp-up time	0V to 4.3V	40	–	–	μs

- VBAT is the main power supply of the chip
- Minimum capacitor value refers to the residual capacitor value after taking into account the part-to-part tolerance, DC-bias, temperature, and aging.
- Total capacitance includes those connected at the far end of the active load.

2.5V LDO (BTLDO2P5)

Table 37: BTLDO2P5 Specifications

Specification	Notes	Minimum	Typical	Maximum	Units
Input supply voltage	Min = 2.5V + 0.2V = 2.7V. Dropout voltage requirement must be met under maximum load for performance specifications.	3.0	3.3	3.6	V
Nominal output voltage	Default = 2.5V.	–	2.5	–	V
Output voltage programmability	Range	2.2	2.5	2.8	V
	Accuracy at any step (including line/load regulation), load > 0.1 mA.	–5	–	5	%
Dropout voltage	At maximum load.	–	–	200	mV
Output current	–	0.1	–	70	mA
Quiescent current	No load.	–	8	16	μA
	Maximum load at 70 mA.	–	660	700	μA
Leakage current	Power-down mode.	–	1.5	5	μA
Line regulation	V_{in} from ($V_o + 0.2V$) to 4.8V, maximum load.	–	–	3.5	mV/V
Load regulation	Load from 1 mA to 70 mA, $V_{in} = 3.6V$.	–	–	0.3	mV/mA
PSRR	$V_{in} \geq V_o + 0.2V$, $V_o = 2.5V$, $C_o = 2.2 \mu F$, maximum load, 100 Hz to 100 kHz.	20	–	–	dB
LDO turn-on time	Chip already powered up.	–	–	150	μs
In-rush current	$V_{in} = V_o + 0.15V$ to 4.8V, $C_o = 2.2 \mu F$, No load.	–	–	250	mA
External output capacitor, C_o	Ceramic, X5R, 0402, (ESR: 5–240 mΩ), ±10%, 10V	0.7 ^a	2.2	2.64	μF
External input capacitor	For SR_VDDBATA5V pin (shared with band gap) ceramic, X5R, 0402, (ESR: 30–200 mΩ), ±10%, 10V. Not needed if sharing VBAT 4.7 μF capacitor with SR_VDDBATP5V.	–	4.7	–	μF

- The minimum value refers to the residual capacitor value after taking into account part-to-part tolerance, DC-bias, temperature, and aging.

CLDO

Table 38: CLDO Specifications

Specification	Notes	Minimum	Typical	Maximum	Units
Input supply voltage, V_{in}	Min = $1.2 + 0.15V = 1.35V$ dropout voltage requirement must be met under maximum load.	1.3	1.35	1.5	V
Output current	–	0.2	–	300	mA
Output voltage, V_o	Programmable in 25 mV steps. Default = 1.2V	1.1	1.2	1.275	V
Dropout voltage	At max load	–	–	150	mV
Output voltage DC accuracy	Includes line/load regulation	–4	–	+4	%
Quiescent current	No load	–	24	–	μA
	300 mA load	–	2.1	–	mA
Line regulation	V_{in} from ($V_o + 0.15V$) to 1.5V, maximum load	–	–	5	mV/V
Load regulation	Load from 1 mA to 300 mA	–	0.02	0.05	mV/mA
Leakage current	Power down	–	–	20	μA
	Bypass mode	–	1	3	μA
PSRR	@1 kHz, $V_{in} \geq 1.35V$, $C_o = 4.7 \mu F$	20	–	–	dB
Start-up time of PMU	VIO up and steady. Time from the REG_ON rising edge to the CLDO reaching 1.2V.	–	–	700	μs
LDO turn-on time	LDO turn-on time when rest of the chip is up	–	140	180	μs
External output capacitor, C_o	Total ESR: 5–240 m Ω	1.32 ^a	4.7	–	μF
External input capacitor	Only use an external input capacitor at the VDD_LDO pin if it is not supplied from CBUCK output.	–	1	2.2	μF

a. Minimum capacitor value refers to the residual capacitor value after taking into account the part-to-part tolerance, DC-bias, temperature, and aging.

LNLDO

Table 39: LNLDO Specifications

Specification	Notes	Minimum	Typical	Maximum	Units
Input supply voltage, V_{in}	Min = $1.2V_o + 0.15V = 1.35V$ dropout voltage requirement must be met under maximum load.	1.3	1.35	1.5	V
Output current	–	0.1	–	150	mA
Output voltage, V_o	Programmable in 25 mV steps. Default = 1.2V	1.1	1.2	1.275	V
Dropout voltage	At maximum load	–	–	150	mV
Output voltage DC accuracy	Includes line/load regulation	–4	–	+4	%
Quiescent current	No load	–	44	–	μA
	Max load	–	970	990	μA
Line Regulation	V_{in} from ($V_o + 0.1V$) to 1.5V, max load	–	–	5	mV/V
Load Regulation	Load from 1 mA to 150 mA	–	0.02	0.05	mV/mA
Leakage current	Power-down	–	–	10	μA
Output noise	@30 kHz, 60–150 mA load $C_o = 2.2 \mu F$	–	–	60	nV/rt Hz
	@100 kHz, 60–150 mA load $C_o = 2.2 \mu F$	–	–	35	nV/rt Hz
PSRR	@1 kHz, Input > 1.35V, $C_o = 2.2 \mu F$, $V_o = 1.2V$	20	–	–	dB
LDO turn-on time	LDO turn-on time when rest of chip is up	–	140	180	μs
External output capacitor, C_o	Total ESR (trace/capacitor): 5–240 m Ω	0.5 ^a	2.2	4.7	μF
External input capacitor	Only use an external input capacitor at the VDD_LDO pin if it is not supplied from CBUCK output. Total ESR (trace/capacitor): 30–200 m Ω	–	1	2.2	μF

- a. Minimum capacitor value refers to the residual capacitor value after taking into account the part-to-part tolerance, DC-bias, temperature, and aging.

Section 16: System Power Consumption



Note: Values in this data sheet are design goals and are subject to change based on the results of device characterization.

Unless otherwise stated, these values apply for the conditions specified in [Table 26: "Recommended Operating Conditions and DC Characteristics,"](#) on page 85.

WLAN Current Consumption

The WLAN current consumption measurements are shown in [Table 40](#).

All values in [Table 40](#) are with the Bluetooth core in reset.

VBAT is the main power supply of the chip (ranges from 3.0 to 3.6V).

Table 40: Typical WLAN Power Consumption

Mode	Bandwidth (MHz)	Band (GHz)	$V_{BAT} = V_{IO} = 3.3V$ (mA)
OFF ^a	–	–	0.01
Sleep ^b	–	–	0.2
IEEE power save, WoWL mode, DTIM 1 1 RX core ^c	20	2.4	3.5
IEEE power save, WoWL mode, DTIM 3 1 RX core ^c	20	2.4	1.5
IEEE power save, WoWL mode, DTIM 1 1 RX core ^c	20	5	2.2
IEEE power save, WoWL mode, DTIM 3 1 RX core ^c	20	5	1.2
IEEE power save, WoWL mode, DTIM 1 1 RX core ^c	40	5	2.4
IEEE power save, WoWL mode, DTIM 3 1 RX core ^c	40	5	1.2
IEEE power save, WoWL mode, DTIM 1 1 RX core ^c	80	5	2.8
IEEE power save, WoWL mode, DTIM 3 1 RX core ^c	80	5	2.5
IEEE power save, DTIM 1 1 RX core ^c	20	2.4	37
IEEE power save, DTIM 3 1 RX core ^c	20	2.4	35.2
IEEE power save, DTIM 1 1 RX core ^c	20	5	35.9
IEEE power save, DTIM 3 1 RX core ^c	20	5	35.2
IEEE power save, DTIM 1 1 RX core ^c	40	5	35.9
IEEE power save, DTIM 3 1 RX core ^c	40	5	35.2
IEEE power save, DTIM 1 1 RX core ^c	80	5	36.1
IEEE power save, DTIM 3 1 RX core ^c	80	5	35.4

Table 40: Typical WLAN Power Consumption (Cont.)

Mode	Bandwidth (MHz)	Band (GHz)	$V_{BAT} = V_{IO} = 3.3V$ (mA)
Active Modes			
Transmit			
Rate 11 (at measured power/core = 18.5 dBm)	20	2.4	365
MCS8, NSS 1 (at measured power/core = 14 dBm)	20	2.4	292
MCS8, NSS 2 (at measured power/core = 14 dBm)	20	2.4	514
MCS7, SGI (at measured power/core = 15 dBm)	20	5	344
MCS15, SGI (at measured power/core = 15 dBm)	20	5	598
MCS7 (at measured power/core = 17 dBm)	40	5	380
MCS9, NSS 1 (at measured power/core = 14.5 dBm)	40	5	363
MCS9, NSS 2 (at measured power/core = 14.5 dBm)	40	5	632
MCS9, NSS 1 (at measured power/core = 13 dBm)	80	5	401
MCS9, NSS 2 (at measured power/core = 13 dBm)	80	5	694
Receive			
1 Mbps, 1 RX core	20	2.4	99
1 Mbps, 2 RX cores	20	2.4	118
MCS7, HT20 1 RX core ^d	20	2.4	100
MCS7, HT20 2 RX cores ^d	20	2.4	123
MCS15, HT20 ^d	20	2.4	130
CRS 1 RX core ^e	20	2.4	94
CRS 2 RX cores ^e	20	2.4	116
Receive MCS7, SGI 1 RX core ^d	20	5	112
Receive MCS7, SGI 2 RX cores ^d	20	5	138
Receiver MCS15, SGI ^d	20	5	148
CRS 1 RX core ^e	20	5	103
CRS 2 RX cores ^e	20	5	128
Receive MCS 7, SGI 1 RX core ^d	40	5	131
Receive MCS 7, SGI 2 RX cores ^d	40	5	170
Receive MCS 15, SGI ^d	40	5	186
CRS 1 RX core ^e	40	5	115
CRS 2 RX cores ^e	40	5	150
Receive MCS9, NSS 1, SGI ^d	80	5	166
Receive MCS9, NSS 1, SGI 2 RX cores ^d	80	5	226
Receive MCS9, NSS 2, SGI ^d	80	5	240
CRS 1 RX core ^e	80	5	145

Table 40: Typical WLAN Power Consumption (Cont.)

Mode	Bandwidth (MHz)	Band (GHz)	$V_{BAT} = V_{IO} = 3.3V$ (mA)
CRS 2 RX cores ^e	80	5	202

- a. WL_REG_ON, BT_REG_ON low, no VDDIO.
- b. Idle, not associated, or inter-beacon.
- c. Beacon Interval = 102.4 ms. Beacon duration = 1 ms @1 Mbps. Average current over three DTIM intervals.
- d. Duty cycle is 100%. Carrier sense (CS) detect/packet receive.
- e. Carrier sense (CCA) when no carrier is present.

Bluetooth Current Consumption

The Bluetooth current consumption measurements are shown in [Table 41](#).



Note:

- VBAT is the main power supply of the chip (ranges from 3.0 to 3.6V).
- The WLAN core is in reset (WL_REG_ON = low) for all measurements provided in [Table 41](#).
- The BT current consumption numbers are measured based on GFSK TX output power = 12 dBm.
- The BT current consumption numbers are measured based on VBAT at 3.3V and VIO at 3.3V.

Table 41: Bluetooth Current Consumption

Operating Mode	$V_{BAT} = V_{IO} = 3.3V$ (mA)
Sleep with external LPOs	1.0
Standard 1.28s inquiry scan	1.2
Standard R1 page and 1.28s inquiry scan	1.3
500 ms sniff att = 4 master	1.2
500 ms sniff att = 4 slave	1.2
DM1/DH1 master TX/RX	25.5
DM3/DH3 master TX/RX	30.9
DM5/DH5 master TX/RX	31.8
3DH1 master TX/RX	23.2
3DH5 master TX/RX	29.5
3DH5 slave TX/RX	29.3
HV3 master (500 ms sniff)	11.7
2EV3 master (500 ms sniff)	8.4
HV3 slave R1 page and 2.56s inquiry scan	11.9
Transmit 100% on maximum OP BDR	49.8
Receive 100% on	17.4
Passive scan 1.28s	1.2
Adv unconnectable 1.00s	1.1
Adv connectable undirected 1.00s	1.1
Connected 1.00s interval master	1.1

Section 17: Interface Timing and AC Characteristics

JTAG Timing

Table 42: JTAG Timing Characteristics

Signal Name	Period	Output Maximum	Output Minimum	Setup	Hold
TCK	125 ns	–	–	–	–
TDI	–	–	–	20 ns	0 ns
TMS	–	–	–	20 ns	0 ns
TDO	–	100 ns	0 ns	–	–
JTAG_TRST	250 ns	–	–	–	–

Section 18: Power-Up Sequence and Timing

Sequencing of Reset and Regulator Control Signals

The BCM43569 has two signals that allow the host to control power consumption by enabling or disabling the Bluetooth, WLAN, and internal regulator blocks. These signals are described below. Additionally, diagrams are provided to indicate proper sequencing of the signals for various operational states (see [Figure 28 on page 113](#), [Figure 29 on page 113](#), and [Figure 30 on page 114](#) and [Figure 31 on page 114](#)). The timing values indicated are minimum required values; longer delays are also acceptable.

Description of Control Signals

- **WL_REG_ON**: Used by the PMU to power up the WLAN section. It is also OR-gated with the BT_REG_ON input to control the internal BCM43569 regulators. When this pin is high, the regulators are enabled and the WLAN section is out of reset. When this pin is low the WLAN section is in reset. If both the BT_REG_ON and WL_REG_ON pins are low, the regulators are disabled.
- **BT_REG_ON**: Used by the PMU (OR-gated with WL_REG_ON) to power up the internal BCM43569 regulators. If both the BT_REG_ON and WL_REG_ON pins are low, the regulators are disabled. When this pin is low and WL_REG_ON is high, the BT section is in reset.



Note:

- VBAT is the main power supply of the chip (ranges from 3.0 to 3.6V).
- For both the WL_REG_ON and BT_REG_ON pins, there should be at least a 100 ms time delay between consecutive toggles (where both signals have been driven low). This is to allow time for the CBUCK regulator to discharge. If this delay is not followed, then there may be a VDDIO in-rush current on the order of 36 mA during the next PMU cold start.
- The BCM43569 has an internal power-on reset (POR) circuit. The device will be held in reset for a maximum of 110 ms after VDDC and VDDIO have both passed the POR threshold.
- VBAT should not rise 10%–90% faster than 40 microseconds. VBAT should be up before or at the same time as VDDIO. VDDIO should NOT be present first or be held high before VBAT is high.

Control Signal Timing Diagrams

Figure 28: WLAN = ON, Bluetooth = ON

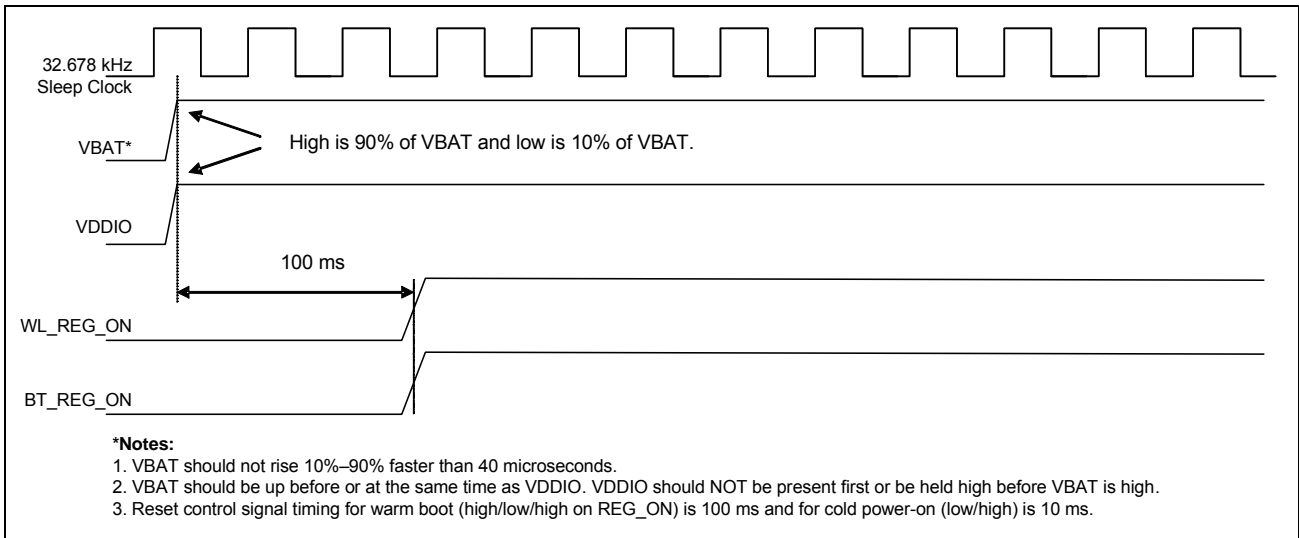

Figure 29: WLAN = OFF, Bluetooth = OFF

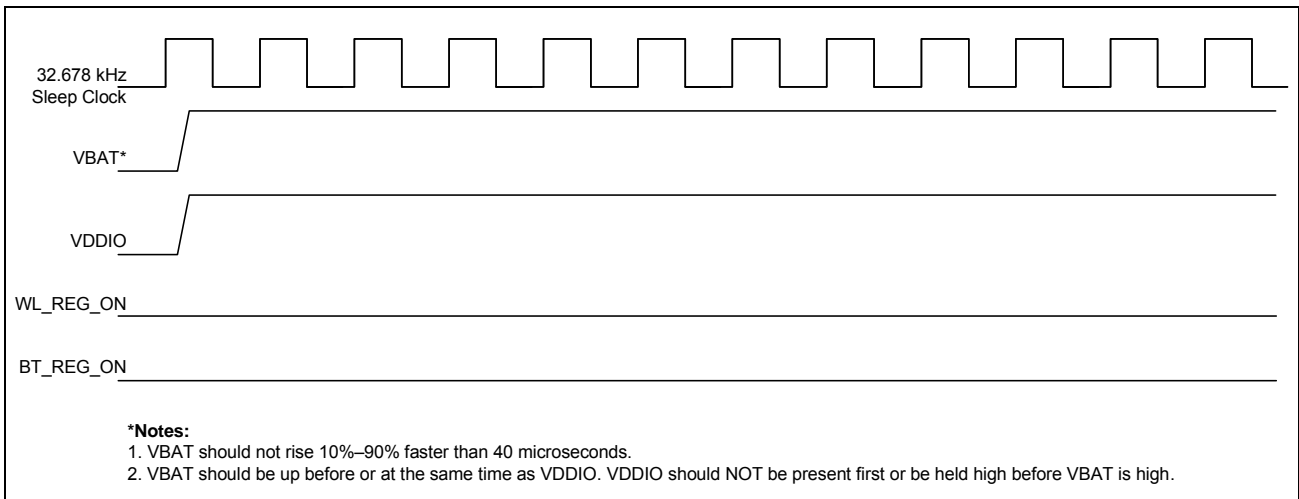

Figure 30: WLAN = ON, Bluetooth = OFF

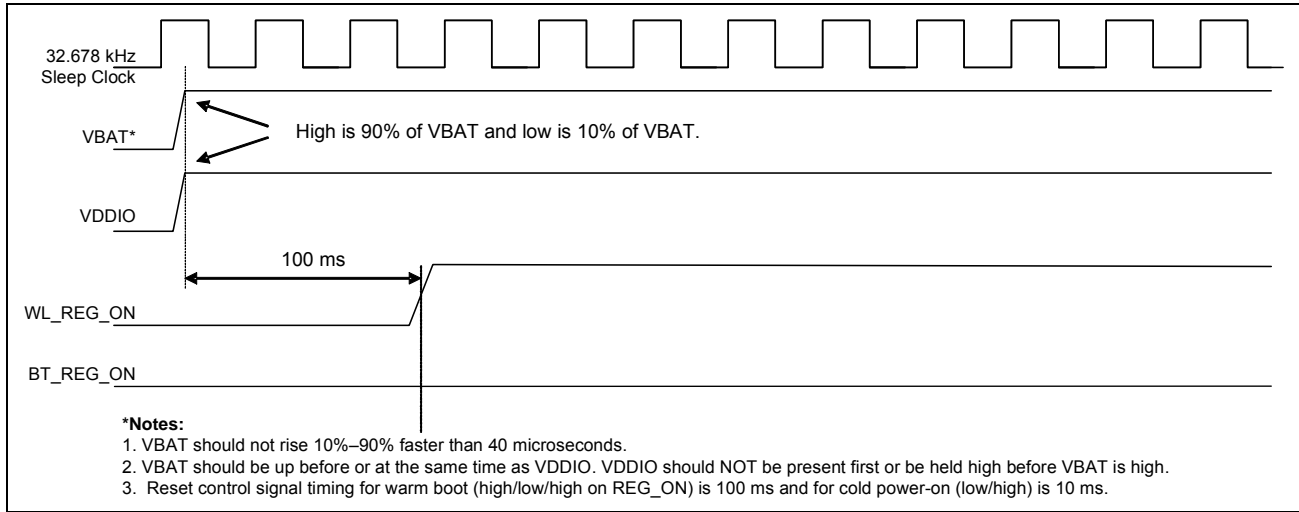

Figure 31: WLAN = OFF, Bluetooth = ON

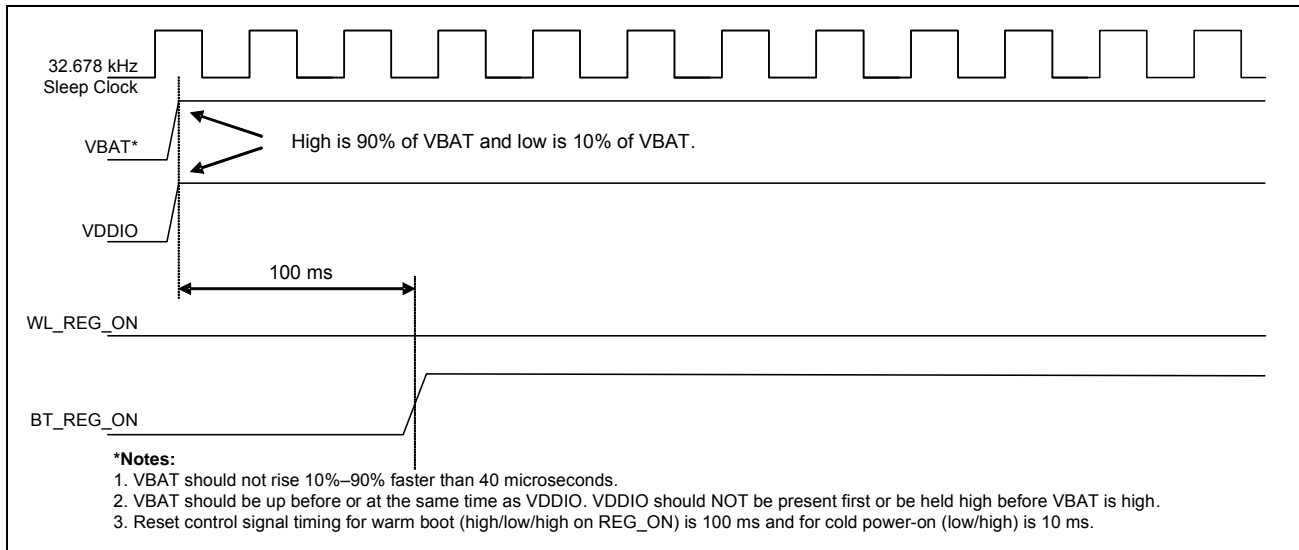

Figure 32 shows the WLAN boot-up sequence from power-up to firmware download.

Figure 32: WLAN Boot-Up Sequence

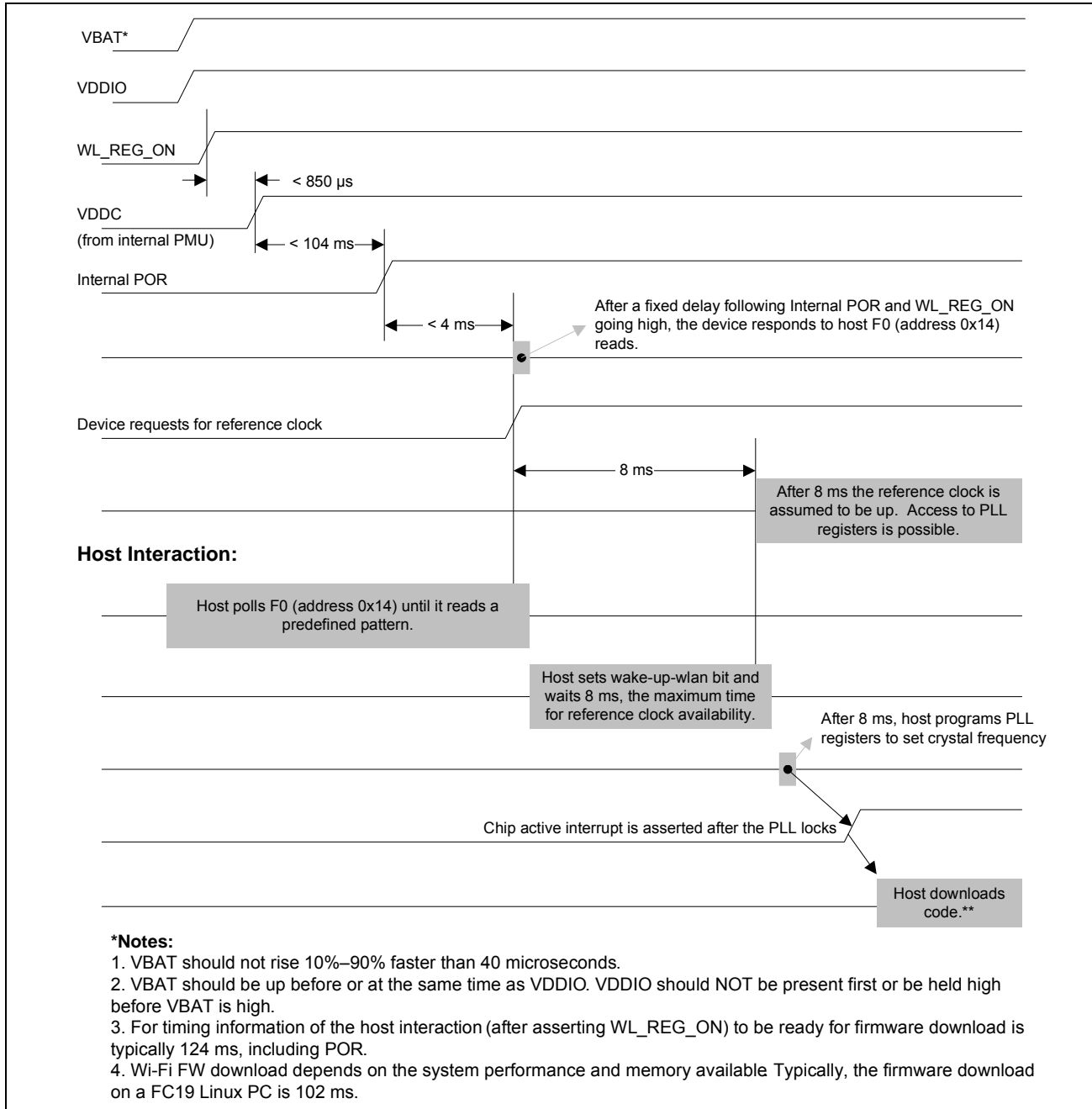
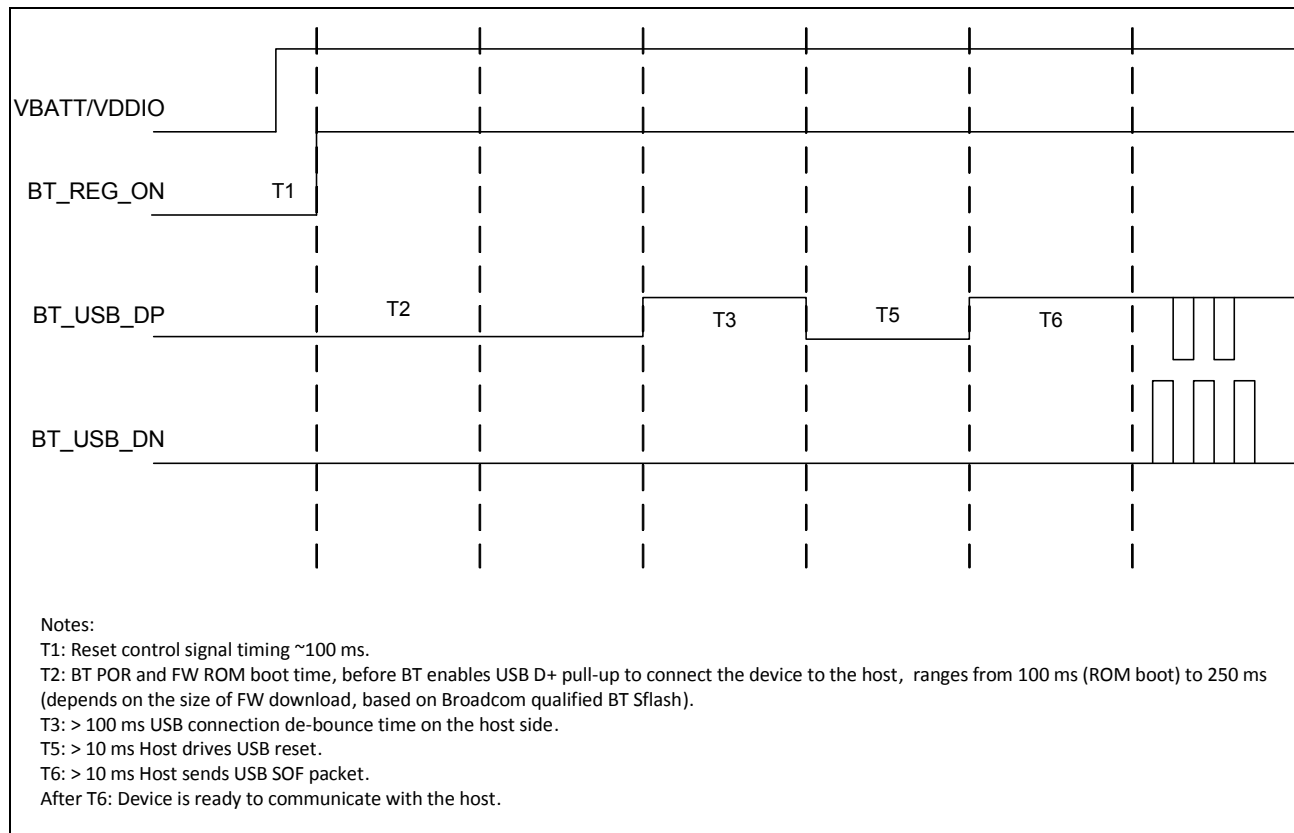

Figure 33 shows the Bluetooth boot-up sequence from power-up to firmware download.

Figure 33: Bluetooth Boot-Up Sequence



Section 19: Package Information

Package Thermal Characteristics

Table 43: Package Thermal Characteristics^a

Characteristic	Value
θ_{JA} (°C/W) (value in still air)	26.38
θ_{JB} (°C/W)	8.37
θ_{JC} (°C/W)	9.94
Ψ_{JT} (°C/W)	6.12
Ψ_{JB} (°C/W)	12.62
Maximum Junction Temperature T_j (°C)	125
Maximum Power Dissipation (W)	2.46

a. No heat sink, $T_A = 60^\circ\text{C}$. This is an estimate, based on a 4-layer PCB that conforms to EIA/JESD51-7 (101.6 mm × 101.6 mm × 1.6 mm) and $P = 1.53\text{W}$ continuous dissipation.

Junction Temperature Estimation and Ψ_{JT} Versus θ_{JC}

The package thermal characterization parameter Ψ_{JT} (Ψ_{JT}) yields a better estimation of actual junction temperature (T_J) than using the junction-to-case thermal resistance parameter θ_{JC} (θ_{JC}). The reason for this is that θ_{JC} is based on the assumption that all the power is dissipated through the top surface of the package case. In actual applications, however, some of the power is dissipated through the bottom and sides of the package. Ψ_{JT} takes into account the power dissipated through the top, bottom, and sides of the package. The equation for calculating the device junction temperature is:

$$T_J = T_T + P \times \Psi_{JT}$$

Where:

- T_J = Junction temperature at steady-state condition (°C)
- T_T = Package case top center temperature at steady-state condition (°C)
- P = Device power dissipation (Watts)
- Ψ_{JT} = Package thermal characteristics; no airflow (°C/W)

Environmental Characteristics

For environmental characteristics data, see [Table 25: “Environmental Ratings,” on page 84.](#)

Section 20: Mechanical Information

Figure 34: 254-Ball Package Mechanical Information

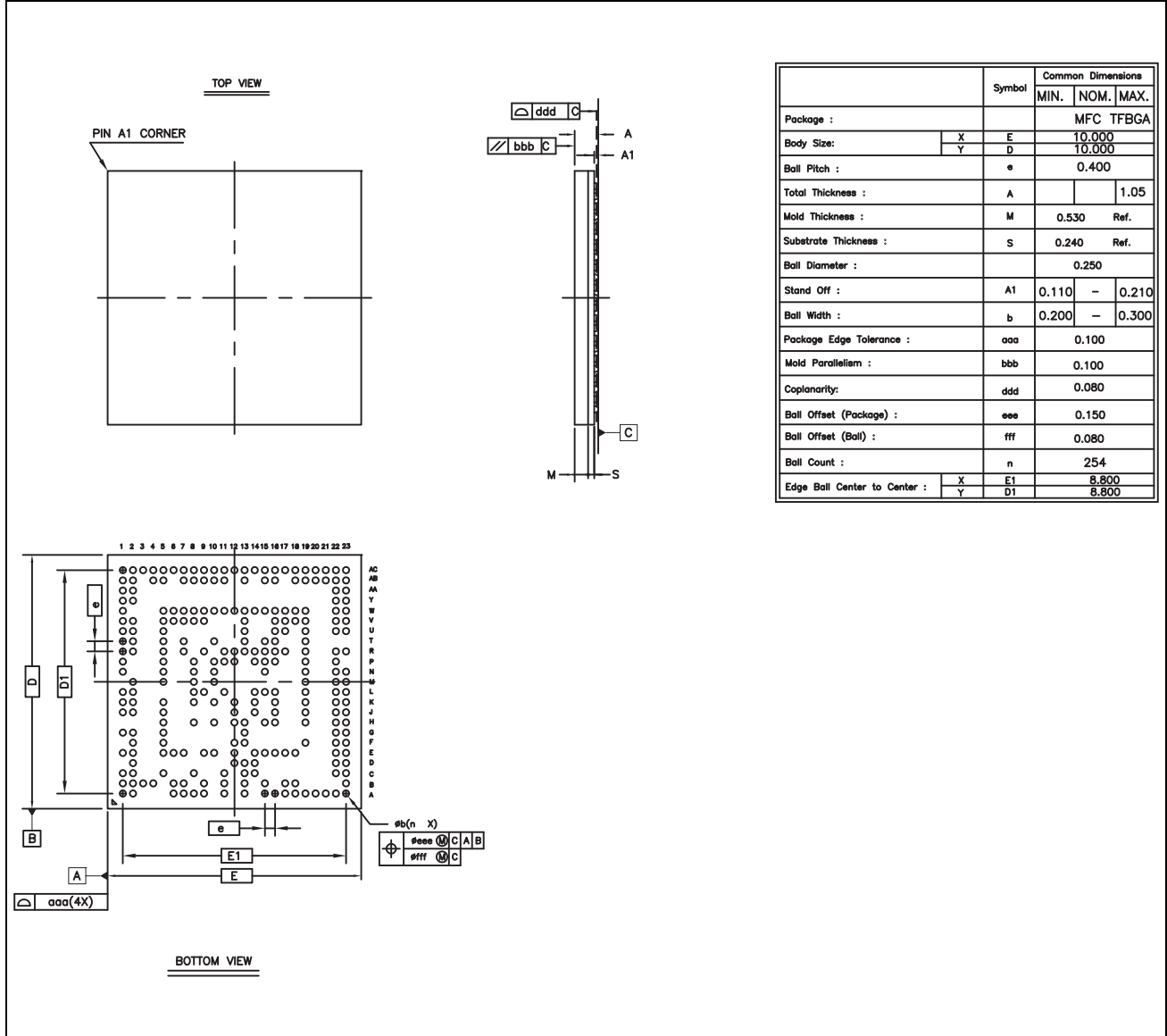

Section 21: Ordering Information

Table 44: Ordering Information

<i>Part Number</i>	<i>Package</i>	<i>Description</i>	<i>Operating Ambient Temperature</i>
BCM43569PKFFBG	254-ball FCBGA (10 mm × 10 mm, 0.4 mm pitch)	Dual-band 2.4 GHz and 5 GHz WLAN + BT 4.1	0°C to +60°C (32°F to 140°F)

Broadcom® Corporation reserves the right to make changes without further notice to any products or data herein to improve reliability, function, or design.

Information furnished by Broadcom Corporation is believed to be accurate and reliable. However, Broadcom Corporation does not assume any liability arising out of the application or use of this information, nor the application or use of any product or circuit described herein, neither does it convey any license under its patent rights nor the rights of others.

Broadcom Corporation

5300 California Avenue
Irvine, CA 92617

© 2016 by BROADCOM CORPORATION. All rights reserved.

43569-DS109-R

January 19, 2016



Phone: 949-926-5000

Fax: 949-926-5203

E-mail: info@broadcom.com

Web: www.broadcom.com

Looking for pricing, stock, or lifecycle information?

Click below to explore more details on WIN SOURCE:

 [View CYW43569PKFFBG on WIN SOURCE](#)

 [Cypress Semiconductor Corp](#) Information

Optimize Your Supply Chain with WIN SOURCE Solutions

-  Global Sourcing Solution
-  Obsolete Management
-  Cost Control Management
-  Shortage Management
-  Alternative Solution
-  Excess Inventory Management