



**THE DATASHEET OF
IS61LP6432A-133TQLI**



64K x 32, 64K x 36 SYNCHRONOUS PIPELINED STATIC RAM

MAY 2017

FEATURES

- Internal self-timed write cycle
- Individual Byte Write Control and Global Write
- Clock controlled, registered address, data and control
- Pentium™ or linear burst sequence control using MODE input
- Three chip enables for simple depth expansion and address pipelining
- Common data inputs and data outputs
- JEDEC 100-Pin TQFP package
- Power-down snooze mode
- Power Supply:
+3.3V V_{DD}
+3.3V or 2.5V V_{DDQ} (I/O)
- Lead-free available

DESCRIPTION

The *ISSI* IS61LP6432A/36A is a high-speed synchronous static RAM designed to provide a burstable, high-performance memory for high speed networking and communication applications. The IS61LP6432A is organized as 64K words by 32 bits and the IS61LP6436A is organized as 64K words by 36 bits. Fabricated with *ISSI*'s advanced CMOS technology, the device integrates a 2-bit burst counter, high-speed SRAM core, and high-drive capability outputs into a single monolithic circuit. All synchronous inputs pass through registers controlled by a positive-edge-triggered single clock input.

Write cycles are internally self-timed and are initiated by the rising edge of the clock input. Write cycles can be from one to four bytes wide as controlled by the write control inputs.

Separate byte enables allow individual bytes to be written. $\overline{BW1}$ controls DQa, $\overline{BW2}$ controls DQb, $\overline{BW3}$ controls DQc, $\overline{BW4}$ controls DQd, conditioned by \overline{BWE} being LOW. A LOW on \overline{GW} input would cause all bytes to be written.

Bursts can be initiated with either \overline{ADSP} (Address Status Processor) or \overline{ADSC} (Address Status Cache Controller) input pins. Subsequent burst addresses can be generated internally and controlled by the \overline{ADV} (burst address advance) input pin.

The mode pin is used to select the burst sequence order, Linear burst is achieved when this pin is tied LOW. Interleave burst is achieved when this pin is tied HIGH or left floating.

FAST ACCESS TIME

Symbol	Parameter	-166	-133	Units
t _{KQ}	Clock Access Time	3.5	4	ns
t _{KC}	Cycle Time	6	7.5	ns
	Frequency	166	133	MHz

Copyright © 2017 Integrated Silicon Solution, Inc. All rights reserved. ISSI reserves the right to make changes to this specification and its products at any time without notice. ISSI assumes no liability arising out of the application or use of any information, products or services described herein. Customers are advised to obtain the latest version of this device specification before relying on any published information and before placing orders for products.

Integrated Silicon Solution, Inc. does not recommend the use of any of its products in life support applications where the failure or malfunction of the product can reasonably be expected to cause failure of the life support system or to significantly affect its safety or effectiveness. Products are not authorized for use in such applications unless Integrated Silicon Solution, Inc. receives written assurance to its satisfaction, that:

- a.) the risk of injury or damage has been minimized;
- b.) the user assume all such risks; and
- c.) potential liability of Integrated Silicon Solution, Inc is adequately protected under the circumstances

BLOCK DIAGRAM

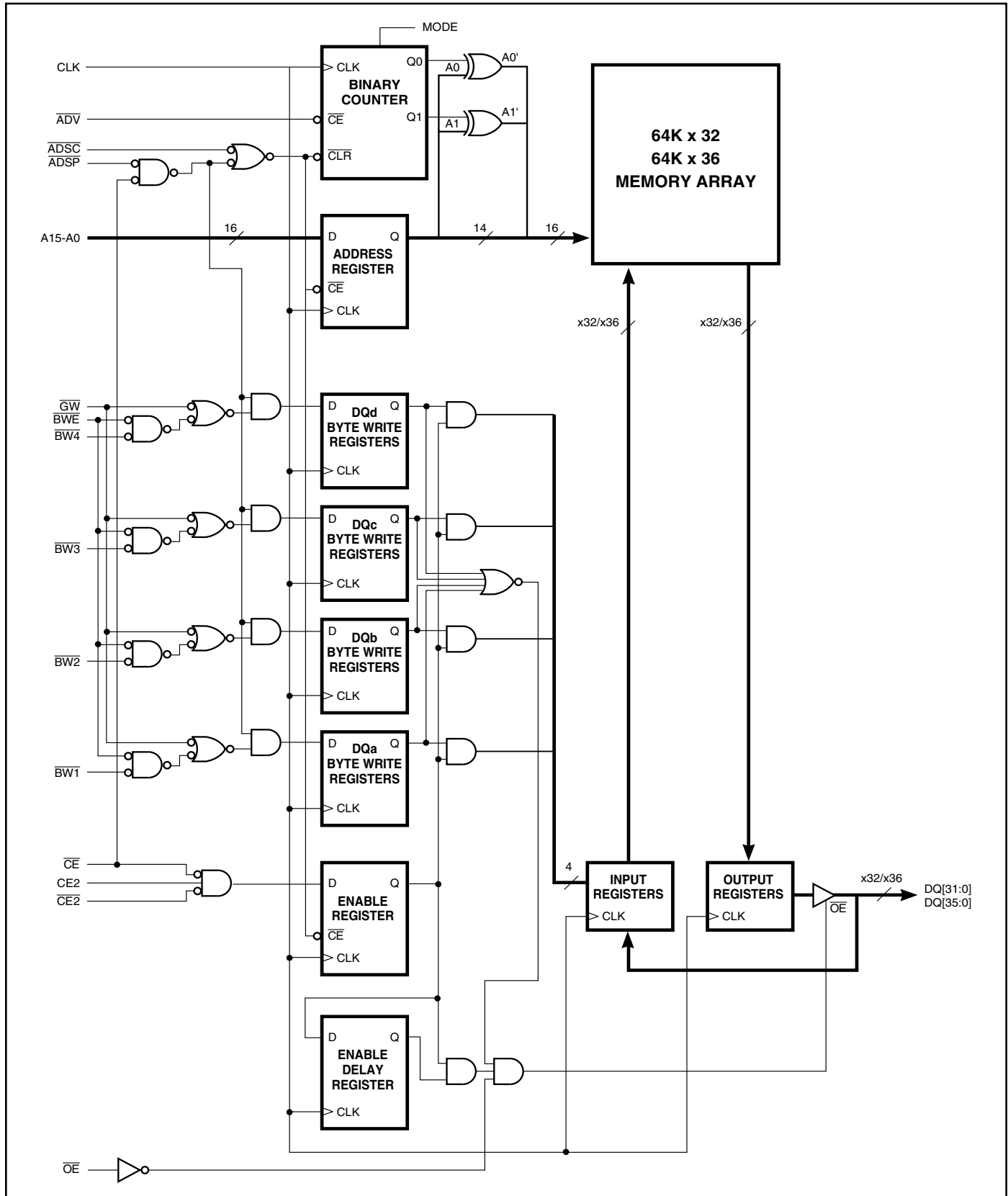

PIN CONFIGURATION

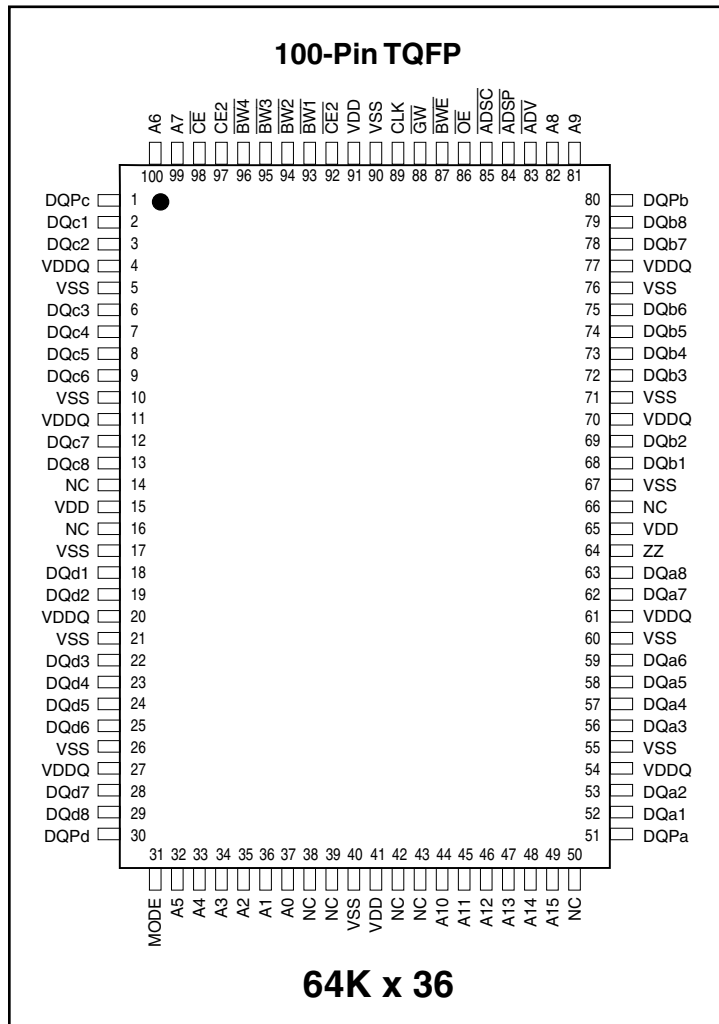

PIN DESCRIPTIONS

A0, A1	Synchronous Address Inputs. These pins must be tied to the two LSBs of the address bus.	\overline{GW}	Synchronous Global Write Enable
A2-A15	Synchronous Address Inputs	\overline{CE} , $\overline{CE2}$, CE2	Synchronous Chip Enable
CLK	Synchronous Clock	\overline{OE}	Output Enable
ADSP	Synchronous Processor Address Status	DQa-DQd	Synchronous Data Input/Output
ADSC	Synchronous Controller Address Status	MODE	Burst Sequence Mode Selection
ADV	Synchronous Burst Address Advance	VDD	+3.3V Power Supply
$\overline{BW1}$ - $\overline{BW4}$	Individual Byte Write Enable	VSS	Ground
BWE	Synchronous Byte Write Enable	VDDQ	Isolated Output Buffer Supply: +3.3V/2.5V
		ZZ	Snooze Enable
		DQP a-DQP d	Parity Data I/O

PIN CONFIGURATION

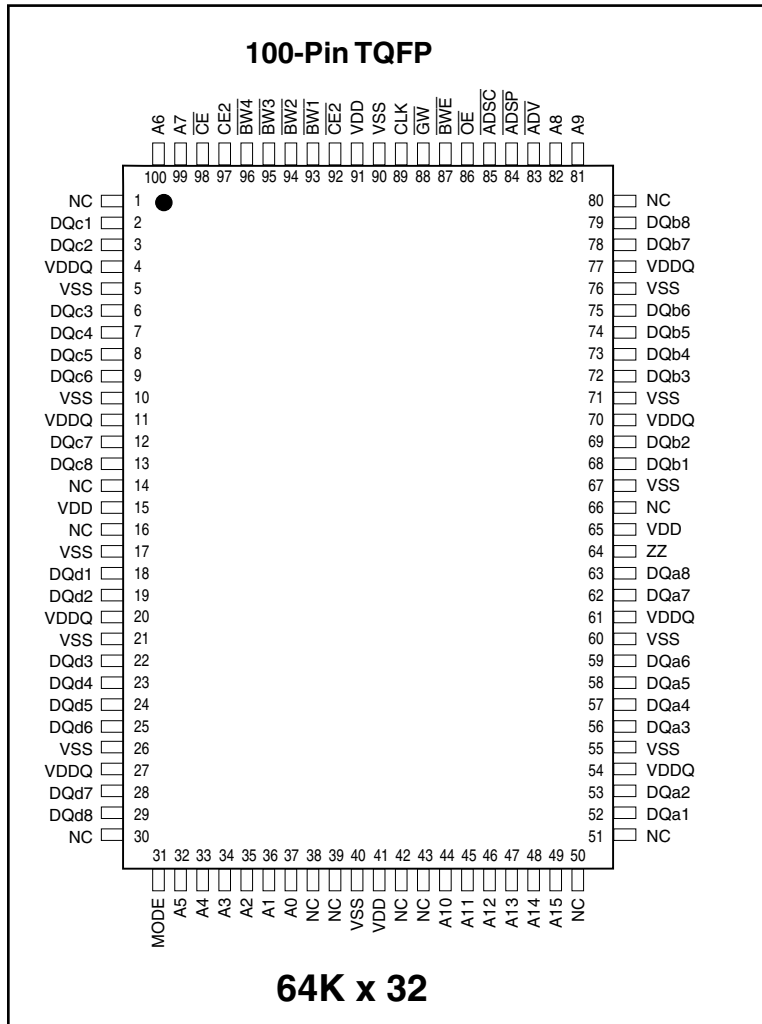

PIN DESCRIPTIONS

A0, A1	Synchronous Address Inputs. These pins must tied to the two LSBs of the address bus.
A2-A15	Synchronous Address Inputs
CLK	Synchronous Clock
ADSP	Synchronous Processor Address Status
ADSC	Synchronous Controller Address Status
ADV	Synchronous Burst Address Advance
BW1-BW4	Individual Byte Write Enable
BWE	Synchronous Byte Write Enable

\overline{GW}	Synchronous Global Write Enable
\overline{CE} , $\overline{CE2}$, CE2	Synchronous Chip Enable
\overline{OE}	Output Enable
DQa-DQd	Synchronous Data Input/Output
MODE	Burst Sequence Mode Selection
VDD	+3.3V Power Supply
Vss	Ground
VDDQ	Isolated Output Buffer Supply: +3.3V/2.5V
ZZ	Snooze Enable

TRUTH TABLE⁽¹⁻⁸⁾

OPERATION	ADDRESS	\overline{CE}	$\overline{CE2}$	CE2	ZZ	\overline{ADSP}	\overline{ADSC}	ADV	WRITE	\overline{OE}	CLK	DQ
Deselect Cycle, Power-Down	None	H	X	X	L	X	L	X	X	X	L-H	High-Z
Deselect Cycle, Power-Down	None	L	X	L	L	L	X	X	X	X	L-H	High-Z
Deselect Cycle, Power-Down	None	L	H	X	L	L	X	X	X	X	L-H	High-Z
Deselect Cycle, Power-Down	None	L	X	L	L	H	L	X	X	X	L-H	High-Z
Deselect Cycle, Power-Down	None	L	H	X	L	H	L	X	X	X	L-H	High-Z
Snooze Mode, Power-Down	None	X	X	X	H	X	X	X	X	X	X	High-Z
Read Cycle, Begin Burst	External	L	L	H	L	L	X	X	X	L	L-H	Q
Read Cycle, Begin Burst	External	L	L	H	L	L	X	X	X	H	L-H	High-Z
Write Cycle, Begin Burst	External	L	L	H	L	H	L	X	L	X	L-H	D
Read Cycle, Begin Burst	External	L	L	H	L	H	L	X	H	L	L-H	Q
Read Cycle, Begin Burst	External	L	L	H	L	H	L	X	H	H	L-H	High-Z
Read Cycle, Continue Burst	Next	X	X	X	L	H	H	L	H	L	L-H	Q
Read Cycle, Continue Burst	Next	X	X	X	L	H	H	L	H	H	L-H	High-Z
Read Cycle, Continue Burst	Next	H	X	X	L	X	H	L	H	L	L-H	Q
Read Cycle, Continue Burst	Next	H	X	X	L	X	H	L	H	H	L-H	High-Z
Write Cycle, Continue Burst	Next	X	X	X	L	H	H	L	L	X	L-H	D
Write Cycle, Continue Burst	Next	H	X	X	L	X	H	L	L	X	L-H	D
Read Cycle, Suspend Burst	Current	X	X	X	L	H	H	H	H	L	L-H	Q
Read Cycle, Suspend Burst	Current	X	X	X	L	H	H	H	H	H	L-H	High-Z
Read Cycle, Suspend Burst	Current	H	X	X	L	X	H	H	H	L	L-H	Q
Read Cycle, Suspend Burst	Current	H	X	X	L	X	H	H	H	H	L-H	High-Z
Write Cycle, Suspend Burst	Current	X	X	X	L	H	H	H	L	X	L-H	D
Write Cycle, Suspend Burst	Current	H	X	X	L	X	H	H	L	X	L-H	D

NOTE:

1. X means "Don't Care." H means logic HIGH. L means logic LOW.
2. For WRITE, L means one or more byte write enable signals ($\overline{BWA-d}$) and \overline{BWE} are LOW or \overline{GW} is LOW. WRITE = H for all \overline{BWx} , BWE, GW HIGH.
3. \overline{BWA} enables WRITES to DQa's and DQPa. \overline{BWb} enables WRITES to DQb's and DQPb. \overline{BWc} enables WRITES to DQc's and DQPC. \overline{BWD} enables WRITES to DQd's and DQPd. DQPa and DQPb are available on the x18 version. DQPa-DQPd are available on the x36 version.
4. All inputs except \overline{OE} and ZZ must meet setup and hold times around the rising edge (LOW to HIGH) of CLK.
5. Wait states are inserted by suspending burst.
6. For a WRITE operation following a READ operation, \overline{OE} must be HIGH before the input data setup time and held HIGH during the input data hold time.
7. This device contains circuitry that will ensure the outputs will be in High-Z during power-up.
8. ADSP LOW always initiates an internal READ at the L-H edge of CLK. A WRITE is performed by setting one or more byte write enable signals and \overline{BWE} LOW or \overline{GW} LOW for the subsequent L-H edge of CLK. See WRITE timing diagram for clarification.

PARTIAL TRUTH TABLE

Function	\overline{GW}	\overline{BWE}	\overline{BWA}	\overline{BWb}	\overline{BWc}	\overline{BWD}
Read	H	H	X	X	X	X
Read	H	L	H	H	H	H
Write Byte 1	H	L	L	H	H	H
Write All Bytes	H	L	L	L	L	L
Write All Bytes	L	X	X	X	X	X

INTERLEAVED BURST ADDRESS TABLE (MODE = V_{DD} or No Connect)

External Address A1 A0	1st Burst Address A1 A0	2nd Burst Address A1 A0	3rd Burst Address A1 A0
00	01	10	11
01	00	11	10
10	11	00	01
11	10	01	00

LINEAR BURST ADDRESS TABLE (MODE = V_{SS})

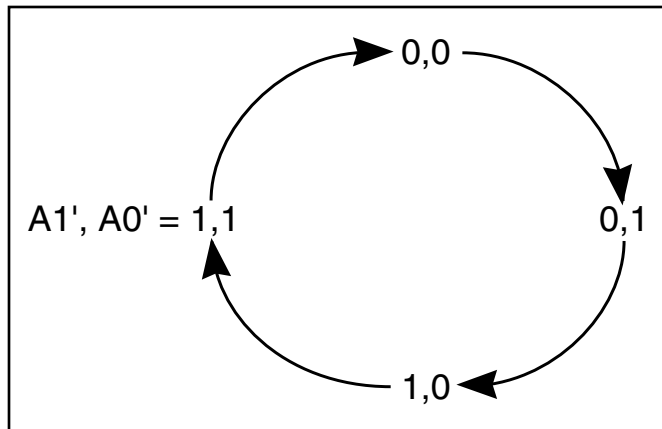

ABSOLUTE MAXIMUM RATINGS⁽¹⁾

Symbol	Parameter	Value	Unit
T _{STG}	Storage Temperature	-55 to +150	°C
P _D	Power Dissipation	1.6	W
I _{OUT}	Output Current (per I/O)	100	mA
V _{IN} , V _{OUT}	Voltage Relative to V _{SS} for I/O Pins	-0.5 to V _{DDQ} + 0.3	V
V _{IN}	Voltage Relative to V _{SS} for Address and Control Inputs	-0.5 to V _{DD} + 0.5	V
V _{DD}	Voltage on V _{DD} Supply Relative to V _{SS}	-0.5 to 4.6	V

Notes:

1. Stress greater than those listed under ABSOLUTE MAXIMUM RATINGS may cause permanent damage to the device. This is a stress rating only and functional operation of the device at these or any other conditions above those indicated in the operational sections of this specification is not implied. Exposure to absolute maximum rating conditions for extended periods may affect reliability.
2. This device contains circuitry to protect the inputs against damage due to high static voltages or electric fields; however, precautions may be taken to avoid application of any voltage higher than maximum rated voltages to this high-impedance circuit.
3. This device contains circuitry that will ensure the output devices are in High-Z at power up.

OPERATING RANGE

Range	Ambient Temperature	V _{DD}	V _{DDQ}
Commercial	0°C to +70°C	3.3V ± 5%	3.3V ± 5% 2.5V ± 5%
Industrial	-40°C to +85°C	3.3V ± 5%	3.3V ± 5% 2.5V ± 5%

DC ELECTRICAL CHARACTERISTICS (Over Operating Range)

Symbol	Parameter	Test Conditions	2.5V (I/O)		3.3V (I/O)		Unit
			Min.	Max.	Min.	Max.	
V _{OH}	Output HIGH Voltage	I _{OH} = -4.0 mA (3.3V) I _{OH} = 1.0 mA (2.5V)	2.0	—	2.4	—	V
V _{OL}	Output LOW Voltage	I _{OL} = 8.0 mA (3.3V) I _{OL} = 1.0 mA (2.5V)	—	0.4	—	0.4	V
V _{IH}	Input HIGH Voltage		1.7	V _{DD} + 0.3	2.0	V _{DD} + 0.3	V
V _{IL}	Input LOW Voltage		-0.3	0.7	-0.3	0.8	V
I _{LI}	Input Leakage Current	V _{SS} ≤ V _{IN} ≤ V _{DD} ⁽¹⁾	-5	5	-5	5	μA
I _{LO}	Output Leakage Current	V _{SS} ≤ V _{OUT} ≤ V _{DDQ} , $\overline{OE} = V_I$	-5	5	-5	5	μA

POWER SUPPLY CHARACTERISTICS (Over Operating Range)

Symbol	Parameter	Test Conditions	-166		-133		Unit
			Max.	Max.	Max.	Max.	
I _{CC}	AC Operating Supply Current	Device Selected, Com.	190	180			mA
		All Inputs = V _{IL} or V _{IH} $\overline{OE} = V_{IH}$, V _{DD} = Max. Cycle Time ≥ t _{kc} min. Ind.	200	190			mA
I _{SB1}	Standby Current	Device Deselected, Com.	70	70			mA
		V _{DD} = Max., Ind. All Inputs = V _{IH} or V _{IL} CLK Cycle Time ≥ t _{kc} min.	80	80			mA
I _{ZZ}	Power-down Mode Current	ZZ = V _{DD} Com.	35	35			mA
		Clock Running Ind. All Inputs ≤ V _{SS} + 0.2V or ≥ V _{DD} - 0.2V	40	40			mA

Notes:

1. The MODE pin has an internal pullup. This pin may be a No Connect, tied to V_{SS}, or tied to V_{DD}.
2. The MODE pin should be tied to V_{DD} or V_{SS}. It exhibits ±10 μA maximum leakage current when tied to ≤ V_{SS} + 0.2V or ≥ V_{DD} - 0.2V.

CAPACITANCE^(1,2)

Symbol	Parameter	Conditions	Max.	Unit
C _{IN}	Input Capacitance	V _{IN} = 0V	6	pF
C _{OUT}	Input/Output Capacitance	V _{OUT} = 0V	8	pF

Notes:

1. Tested initially and after any design or process changes that may affect these parameters.
2. Test conditions: T_A = 25°C, f = 1 MHz, V_{DD} = 3.3V.

3.3V I/O AC TEST CONDITIONS

Parameter	Unit
Input Pulse Level	0V to 3.0V
Input Rise and Fall Times	1ns
Input and Output Timing and Reference Level	1.5V
Output Load	See Figures 1 and 2

3.3V I/O OUTPUT LOAD EQUIVALENT

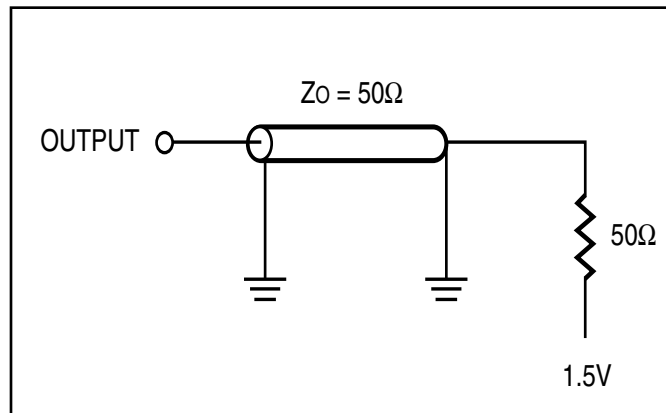

Figure 1

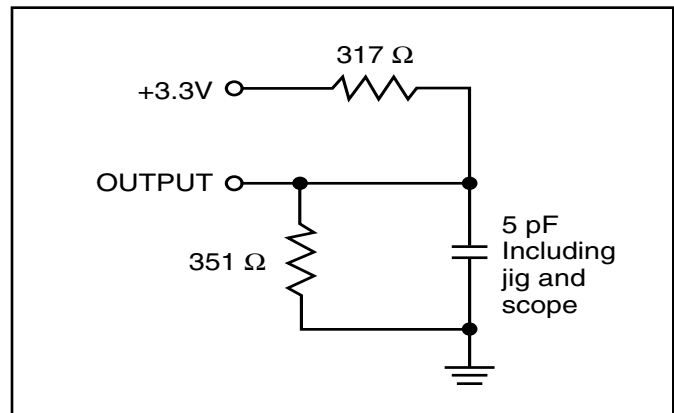

Figure 2

2.5V I/O AC TEST CONDITIONS

Parameter	Unit
Input Pulse Level	0V to 2.5V
Input Rise and Fall Times	1 ns
Input and Output Timing and Reference Level	1.25V
Output Load	See Figures 3 and 4

2.5V I/O OUTPUT LOAD EQUIVALENT

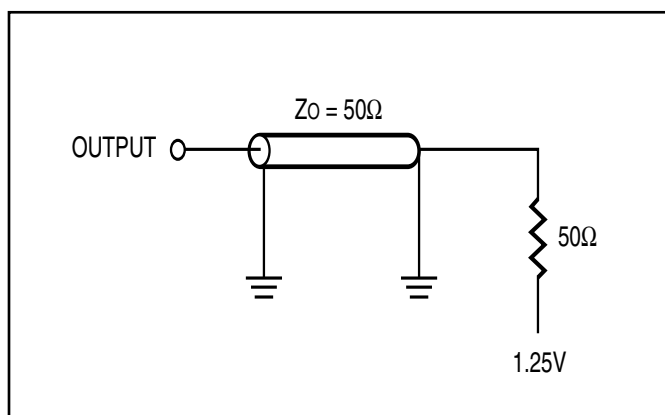

Figure 3

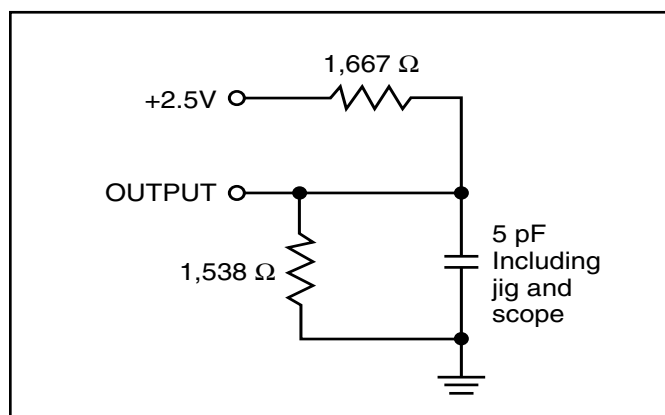

Figure 4

READ/WRITE CYCLE SWITCHING CHARACTERISTICS (Over Operating Range)

Symbol	Parameter	-166		-133		Unit
		Min.	Max.	Min.	Max.	
f _{MAX} ⁽³⁾	Clock Frequency	—	166	—	133	MHz
t _{CC} ⁽³⁾	Cycle Time	6	—	7.5	—	ns
t _{KH}	Clock High Time	2.4	—	2.8	—	ns
t _{KL} ⁽³⁾	Clock Low Time	2.4	—	2.8	—	ns
t _Q ⁽³⁾	Clock Access Time	—	3.5	—	4	ns
t _{QOX} ⁽¹⁾	Clock High to Output Invalid	3	—	3	—	ns
t _{QOZ} ^(1,2)	Clock High to Output Low-Z	0	—	0	—	ns
t _{QOZH} ^(1,2)	Clock High to Output High-Z	1.5	3.5	1.5	3.5	ns
t _{OEQ} ⁽³⁾	Output Enable to Output Valid	—	3.5	—	3.8	ns
t _{OEQX} ⁽¹⁾	Output Disable to Output Invalid	0	—	0	—	ns
t _{OELZ} ^(1,2)	Output Enable to Output Low-Z	0	—	0	—	ns
t _{OEHZ} ^(1,2)	Output Disable to Output High-Z	2	4.5	2	5	ns
t _{AS} ⁽³⁾	Address Setup Time	2.1	—	2.1	—	ns
t _{SS} ⁽³⁾	Address Status Setup Time	1.5	—	1.5	—	ns
t _{WS} ⁽³⁾	Write Setup Time	1.5	—	1.5	—	ns
t _{CES} ⁽³⁾	Chip Enable Setup Time	1.5	—	1.5	—	ns
t _{AVS} ⁽³⁾	Address Advance Setup Time	1.5	—	1.5	—	ns
t _{AH} ⁽³⁾	Address Hold Time	1.0	—	1.0	—	ns
t _{SH} ⁽³⁾	Address Status Hold Time	0.5	—	0.5	—	ns
t _{WH} ⁽³⁾	Write Hold Time	0.5	—	0.5	—	ns
t _{CEH} ⁽³⁾	Chip Enable Hold Time	0.5	—	0.5	—	ns
t _{AVH} ⁽³⁾	Address Advance Hold Time	0.5	—	0.5	—	ns

Note:

1. Guaranteed but not 100% tested. This parameter is periodically sampled.
2. Tested with load in Figure 2.
3. Tested with load in Figure 1.

READ/WRITE CYCLE TIMING

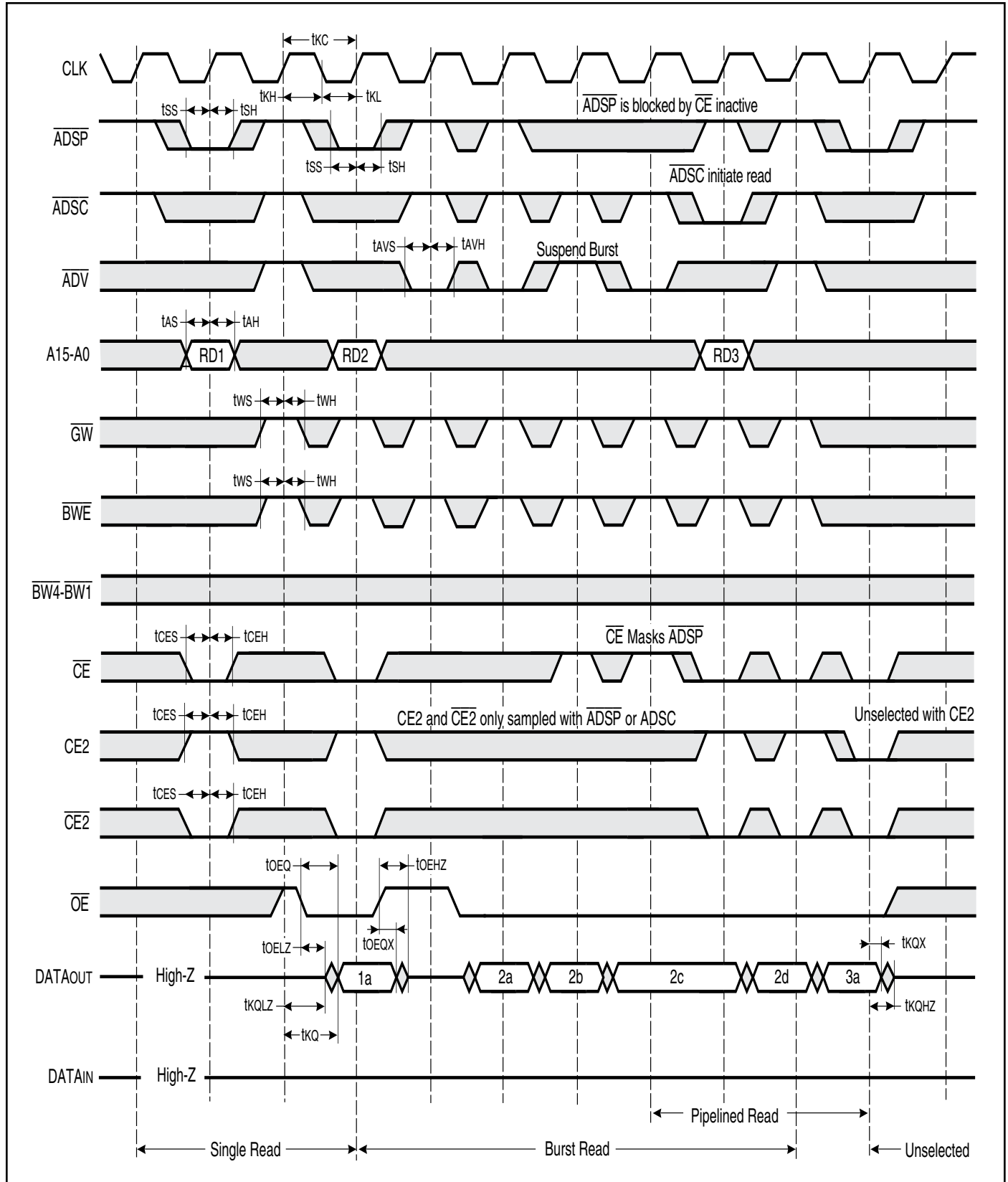

WRITE CYCLE SWITCHING CHARACTERISTICS (Over Operating Range)

Symbol	Parameter	-166		-133		Unit
		Min.	Max.	Min.	Max.	
t _{CC} ⁽¹⁾	Cycle Time	6	—	7.5	—	ns
t _{CH} ⁽¹⁾	Clock High Time	2.4	—	2.8	—	ns
t _{CL} ⁽¹⁾	Clock Low Time	2.4	—	2.8	—	ns
t _{AS} ⁽¹⁾	Address Setup Time	2.1	—	2.1	—	ns
t _{SS} ⁽¹⁾	Address Status Setup Time	1.5	—	1.5	—	ns
t _{WS} ⁽¹⁾	Write Setup Time	1.5	—	1.5	—	ns
t _{DS} ⁽¹⁾	Data In Setup Time	1.5	—	1.5	—	ns
t _{CES} ⁽¹⁾	Chip Enable Setup Time	1.5	—	1.5	—	ns
t _{AVS} ⁽¹⁾	Address Advance Setup Time	1.5	—	1.5	—	ns
t _{AH} ⁽¹⁾	Address Hold Time	1.0	—	1.0	—	ns
t _{SH} ⁽¹⁾	Address Status Hold Time	0.5	—	0.5	—	ns
t _{DH} ⁽¹⁾	Data In Hold Time	1.0	—	1.0	—	ns
t _{WH} ⁽¹⁾	Write Hold Time	0.5	—	0.5	—	ns
t _{CEH} ⁽¹⁾	Chip Enable Hold Time	0.5	—	0.5	—	ns
t _{AVH} ⁽¹⁾	Address Advance Hold Time	0.5	—	0.5	—	ns

Note:

1. Tested with load in Figure 1.

WRITE CYCLE TIMING

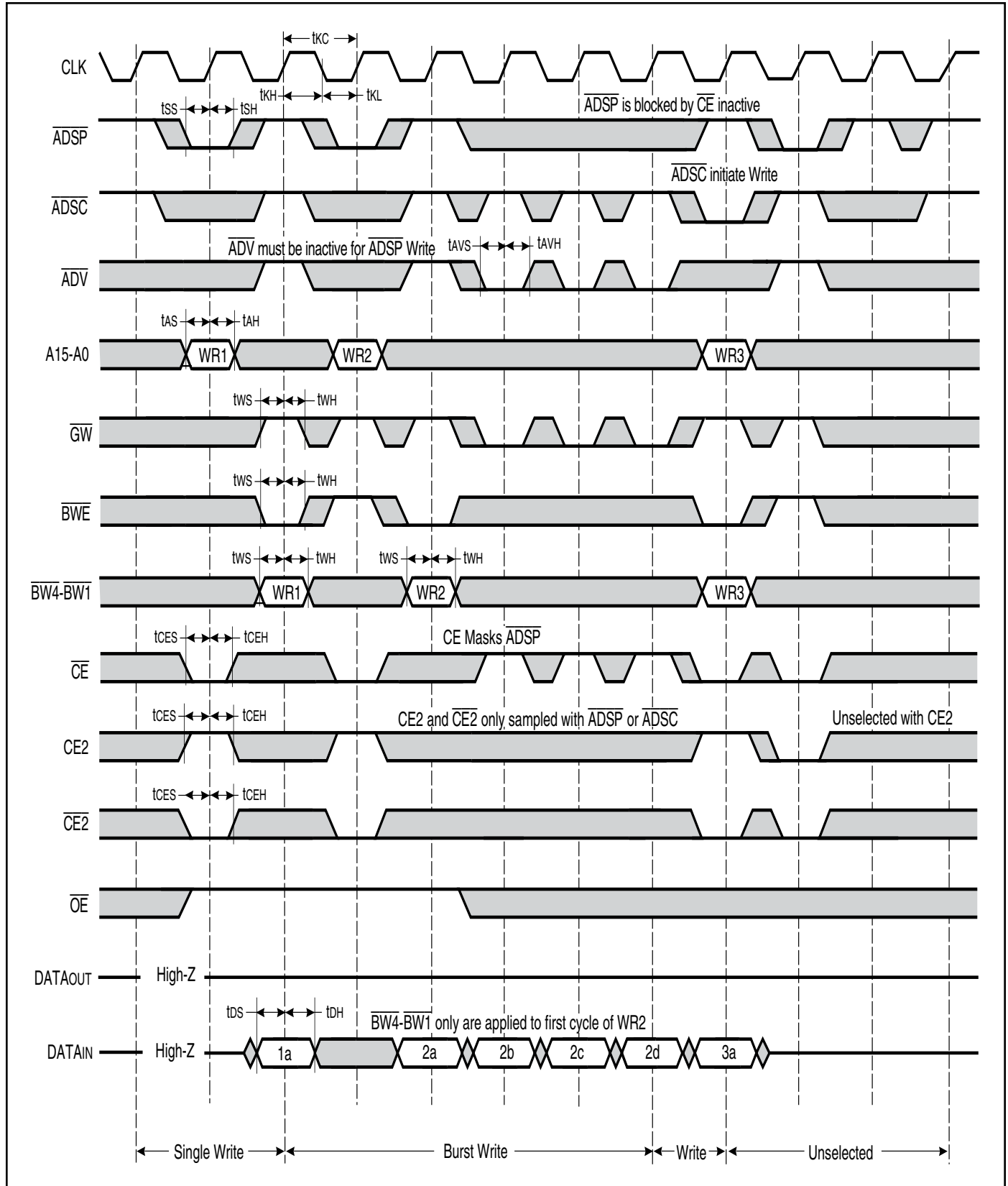

SNOOZE AND RECOVERY CYCLE SWITCHING CHARACTERISTICS (Over Operating Range)

Symbol	Parameter	-166		-133		Unit
		Min.	Max.	Min.	Max.	
tkC ⁽³⁾	Cycle Time	6	—	7.5	—	ns
tkH ⁽³⁾	Clock High Time	2.4	—	2.8	—	ns
tkL ⁽³⁾	Clock Low Time	2.4	—	2.8	—	ns
tkQ ⁽³⁾	Clock Access Time	—	3.5	—	4	ns
tkQX ⁽¹⁾	Clock High to Output Invalid	1.5	—	1.5	—	ns
tkQLZ ^(1,2)	Clock High to Output Low-Z	0	—	0	—	ns
tkQHZ ^(1,2)	Clock High to Output High-Z	1.5	3.5	1.5	3.5	ns
toEQ ⁽³⁾	Output Enable to Output Valid	—	3.5	—	3.9	ns
toEQX ⁽¹⁾	Output Disable to Output Invalid	0	—	0	—	ns
toELZ ^(1,2)	Output Enable to Output Low-Z	0	—	0	—	ns
toEHZ ^(1,2)	Output Disable to Output High-Z	2	4.5	2	5.0	ns
tAS ⁽³⁾	Address Setup Time	2.1	—	2.1	—	ns
tSS ⁽³⁾	Address Status Setup Time	1.5	—	1.5	—	ns
tCES ⁽³⁾	Chip Enable Setup Time	1.5	—	1.5	—	ns
tAH ⁽³⁾	Address Hold Time	1.0	—	1.0	—	ns
tSH ⁽³⁾	Address Status Hold Time	0.5	—	0.5	—	ns
tCEH ⁽³⁾	Chip Enable Hold Time	0.5	—	0.5	—	ns
tZS	ZZ Standby	2	—	2	—	cyc
tZREC	ZZ Recovery	2	—	2	—	cyc

Notes:

1. Guaranteed but not 100% tested. This parameter is periodically sampled.
2. Tested with load in Figure 2.
3. Tested with load in Figure 1.

SNOOZE AND RECOVERY CYCLE TIMING

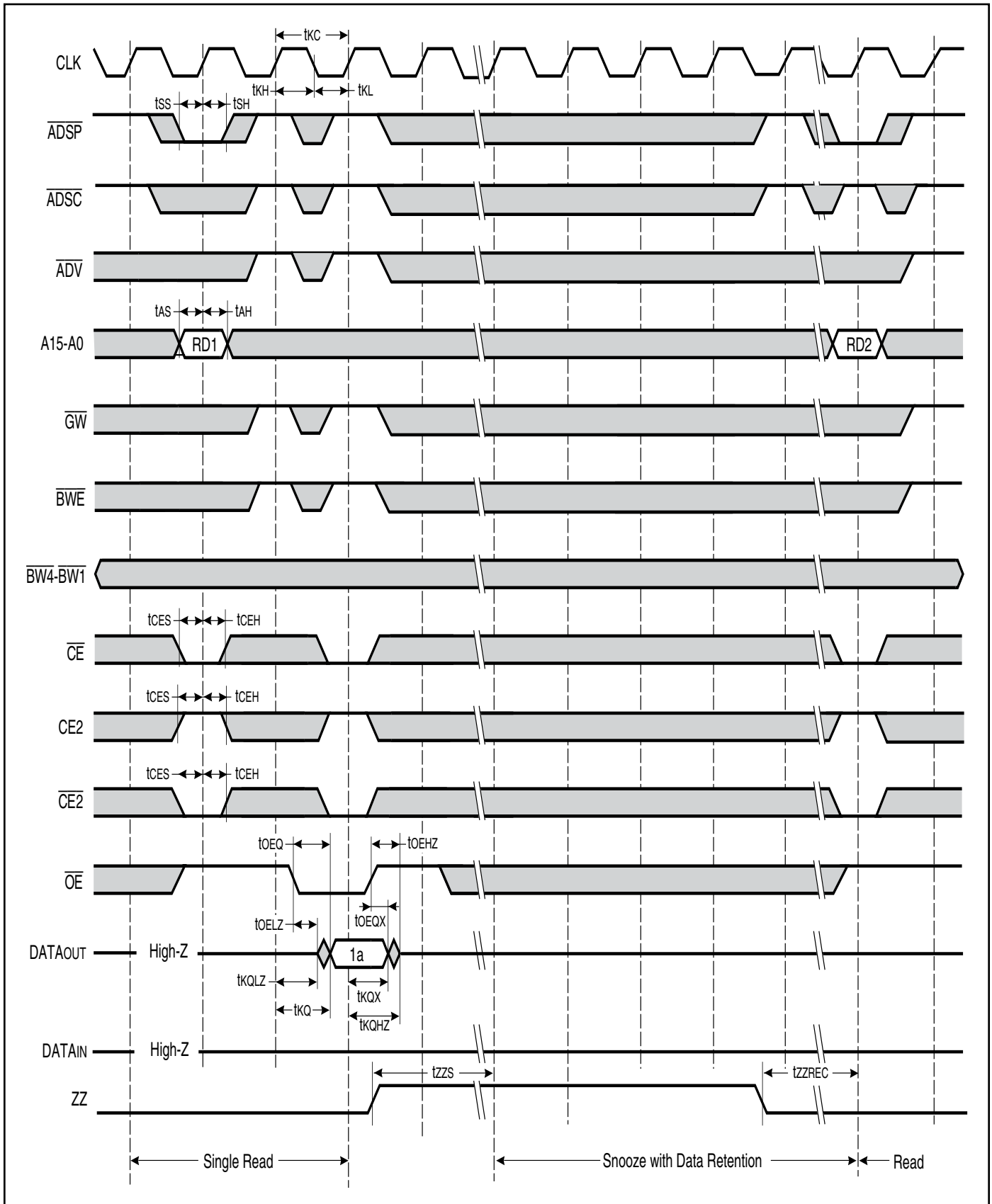

ORDERING INFORMATION: IS61LP6432A

Industrial Range: -40°C to +85°C

Speed	Order Part Number	Package
133 MHz	IS61LP6432A-133TQLI	TQFP, Lead-free

ORDERING INFORMATION: IS61LP6436A

Industrial Range: -40°C to +85°C

Speed	Order Part Number	Package
166 MHz	IS61LP6436A-166TQLI	TQFP, Lead-free
133 MHz	IS61LP6436A-133TQLI	TQFP, Lead-free

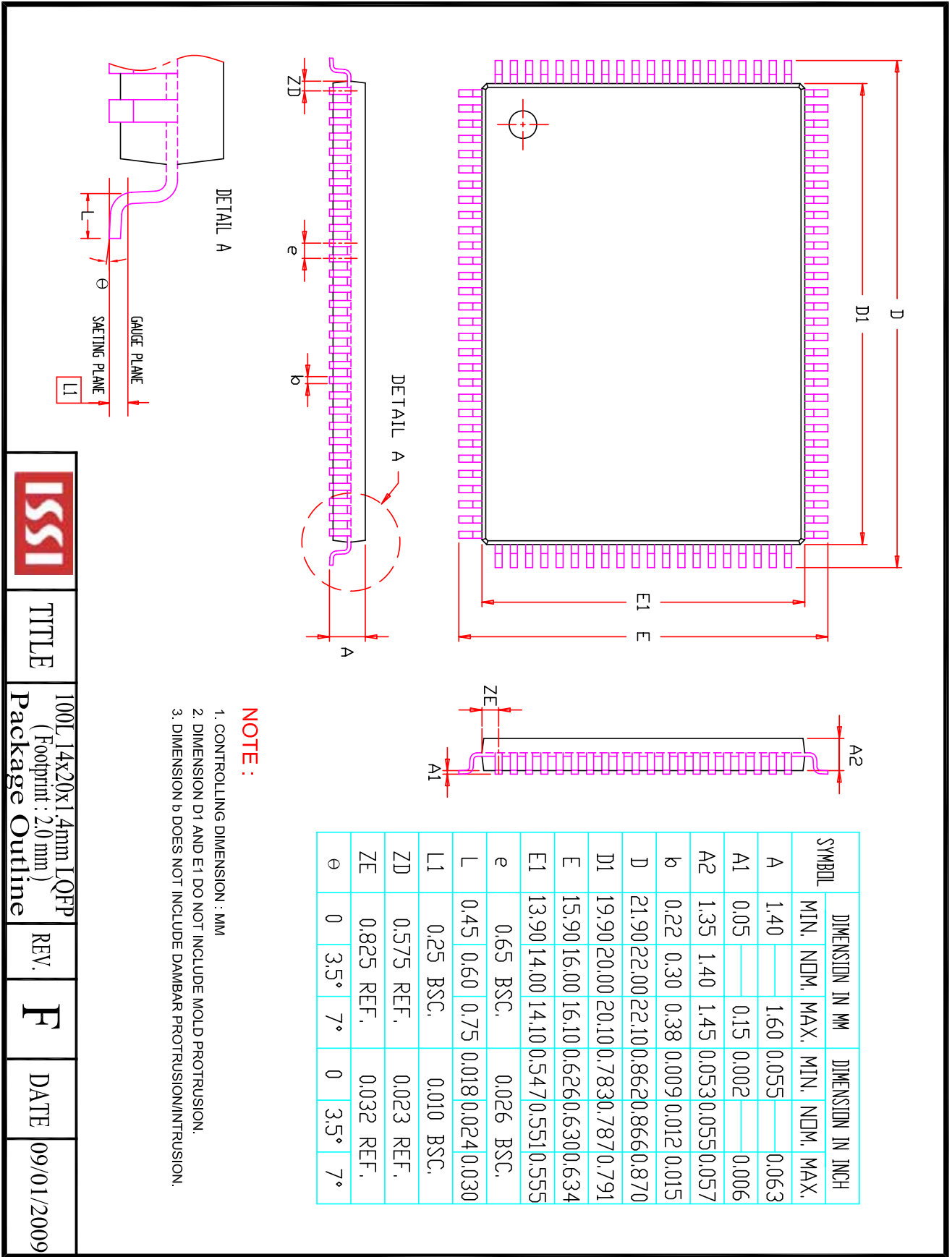

SYMBOL	DIMENSION IN MM		DIMENSION IN INCH	
	MIN.	NOM. MAX.	MIN.	NOM. MAX.
A	1.40	1.60	0.055	0.063
A1	0.05	0.15	0.002	0.006
A2	1.35	1.45	0.053	0.057
b	0.22	0.30	0.009	0.012
D	21.90	22.00	0.862	0.870
D1	19.90	20.00	0.783	0.791
E	15.90	16.10	0.626	0.634
E1	13.90	14.10	0.547	0.555
e	0.65	BSC.	0.026	BSC.
L	0.45	0.60	0.018	0.030
L1	0.25	BSC.	0.010	BSC.
ZD	0.575	REF.	0.023	REF.
ZE	0.825	REF.	0.032	REF.
theta	0	3.5°	0	7°



NOTE :
 1. CONTROLLING DIMENSION : MM
 2. DIMENSION D1 AND E1 DO NOT INCLUDE MOLD PROTRUSION.
 3. DIMENSION b DOES NOT INCLUDE DAMBAR PROTRUSION/INTRUSION.

	TITLE	100L 14x20x1.4mm LQFP (Footprint : 2.0 mm)	REV.	F	DATE	09/01/2009
	Package Outline					

280-600-011 REV. A

Looking for pricing, stock, or lifecycle information?

Click below to explore more details on WIN SOURCE:

-  [View IS61LP6432A-133TQLI on WIN SOURCE](#)
-  [ISSI, Integrated Silicon Solution Inc Information](#)

Optimize Your Supply Chain with WIN SOURCE Solutions

-  Global Sourcing Solution
-  Obsolete Management
-  Cost Control Management
-  Shortage Management
-  Alternative Solution
-  Excess Inventory Management