



**THE DATASHEET OF
IR3502AMTRPBF**



DESCRIPTION

The IR3502A control IC combined with an *XPHASE3*[™] Phase IC provides a full featured and flexible way to implement a complete VR11.0 and VR11.1 power solution. The IR3502A provides overall system control and interfaces with any number of Phase ICs, each driving and monitoring a single phase. The *XPhase3*[™] architecture results in a power supply that is smaller, less expensive, and easier to design while providing higher efficiency than conventional approaches.

FEATURES

- 1 to X phase operation with matching Phase IC
- 0.5% overall system set point accuracy
- Daisy-chain digital phase timing provides accurate phase interleaving without external components
- Programmable 250kHz to 9MHz clock oscillator frequency provides per phase switching frequency of 250kHz to 1.5MHz
- Programmable Dynamic VID Slew Rate
- Programmable VID Offset or No Offset
- Programmable Load Line Output Impedance
- High speed error amplifier with wide bandwidth of 30MHz and fast slew rate of 10V/us
- Programmable constant converter output current limit during soft start
- Hiccup over current protection with delay during normal operation
- Central over voltage detection and latch with programmable threshold and communication to phase ICs
- Over voltage signal output to system with overvoltage detection during powerup and normal operation
- Load current reporting
- Single NTC thermistor compensation for correct current reporting, OC Threshold, and Droop
- Detection and protection of open remote sense line
- Open control loop protection
- IC bias linear regulator controller
- Programmable VRHOT function monitors temperature of power stage through a NTC thermistor
- Remote sense amplifier with true converter voltage sensing
- Small thermally enhanced 32L 5mm x 5mm MLPQ package
- RoHS Compliant

ORDERING INFORMATION

Device	Package	Order Quantity
IR3502AMTRPBF	32 Lead MLPQ (5 x 5 mm body)	3000 per reel
* IR3502AMPBF	32 Lead MLPQ (5 x 5 mm body)	100 piece strips

- Samples only

APPLICATION CIRCUIT

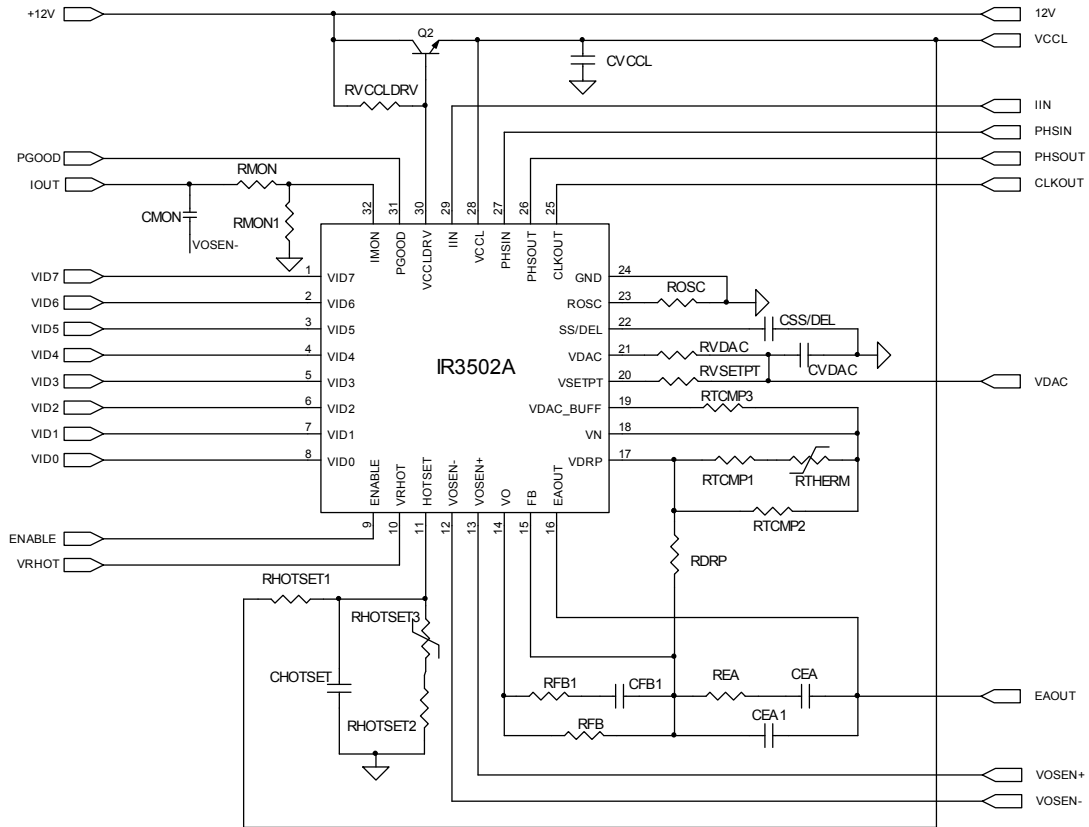

Figure 1: IR3502A Application Circuit

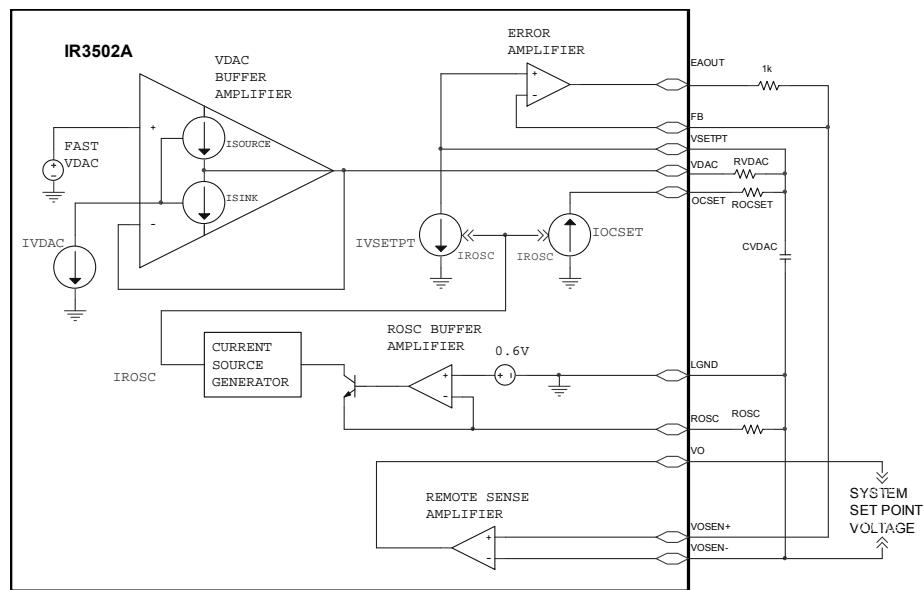

Figure 2 -System-set point measurements.

ABSOLUTE MAXIMUM RATINGS

Stresses beyond those listed under “Absolute Maximum Ratings” may cause permanent damage to the device. These are stress ratings only and functional operation of the device at these or any other conditions beyond those indicated in the operational sections of the specifications are not implied.

Operating Junction Temperature.....0 to 150°C
 Storage Temperature Range.....-65°C to 150°C
 ESD Rating.....HBM Class 1C JEDEC Standard
 MSL Rating.....2
 Reflow Temperature.....260°C

PIN #	PIN NAME	V _{MAX}	V _{MIN}	I _{SOURCE}	I _{SINK}
1-8	VID7-0	7.5V	-0.3V	1mA	1mA
9	ENABLE	3.5V	-0.3V	1mA	1mA
10	VRHOT	7.5V	-0.3V	1mA	50mA
11	HOTSET	7.5V	-0.3V	1mA	1mA
12	VOSEN-	1.0V	-0.5V	5mA	1mA
13	VOSEN+	7.5V	-0.5V	5mA	1mA
14	VO	7.5V	-0.5V	35mA	5mA
15	FB	7.5V	-0.3V	1mA	1mA
16	EAOUT	7.5V	-0.3V	35mA	5mA
17	VDRP	7.5V	-0.3V	35mA	1mA
18	VN	7.5V	-0.3V	1mA	1mA
19	VDAC_BUFF	3.5V	-0.3V	1mA	35mA
20	VSETPT	3.5V	-0.3V	1mA	1mA
21	VDAC	3.5V	-0.3V	1mA	1mA
22	SS/DEL	7.5V	-0.3V	1mA	1mA
23	ROSC/OVP	7.5V	-0.5V	1mA	1mA
24	LGND	n/a	n/a	20mA	1mA
25	CLKOUT	7.5V	-0.3V	100mA	100mA
26	PHSOUT	7.5V	-0.3V	10mA	10mA
27	PHSIN	7.5V	-0.3V	1mA	1mA
28	VCCL	7.5V	-0.3V	1mA	20mA
29	IIN	7.5V	-0.3V	1mA	1mA
30	VCCLDRV	10V	-0.3V	1mA	50mA
31	PGOOD	VCCL + 0.3V	-0.3V	1mA	20mA
32	IMON	3.5V	-0.3V	25mA	1mA

ELECTRICAL SPECIFICATIONS

Unless otherwise specified, these specifications apply over: $8V \leq V_{in} \leq 16V$, $V_{CCL} = 6.8V \pm 3.4\%$, $-0.3V \leq V_{OSEN} \leq 0.3V$, $0^\circ C \leq T_j \leq 100^\circ C$, $7.75K\Omega \leq R_{OSC} \leq 50.0 K\Omega$, $C_{SS/DEL} = 0.1\mu F \pm 10\%$.

PARAMETER	TEST CONDITION	MIN	TYP	MAX	UNIT
VDAC Reference					
System Set-Point Accuracy	$VID \geq 1V$	-0.5		0.5	%
	$0.8V \leq VID < 1V$	-5		+5	mV
	$0.5V \leq VID < 0.8V$	-8		+8	mV
Source & Sink Currents	Include OCSET and VSETPT currents	30	44	58	μA
VIDx Input Threshold		500	600	700	mV
VIDx Input Bias Current	$0V \leq V(VIDx) \leq 2.5V$.	-1	0	1	μA
VIDx OFF State Blanking Delay	Measure time till PGOOD drives low	0.5	1.3	2.1	μs
Oscillator					
ROSC Voltage		0.570	0.595	0.620	V
CLKOUT High Voltage	$I(CLKOUT) = -10 \text{ mA}$, measure $V(V_{CCL}) - V(CLKOUT)$.			1	V
CLKOUT Low Voltage	$I(CLKOUT) = 10 \text{ mA}$			1	V
PHSOUT Frequency	$R_{osc} = 50.0 K\Omega$	225	250	275	kHz
PHSOUT Frequency	$R_{osc} = 24.5 K\Omega$	450	500	550	kHz
PHSOUT Frequency	$R_{osc} = 7.75 K\Omega$	1.35	1.50	1.65	MHz
PHSOUT High Voltage	$I(PHSOUT) = -1 \text{ mA}$, measure $V(V_{CCL}) - V(PHSOUT)$			1	V
PHSOUT Low Voltage	$I(PHSOUT) = 1 \text{ mA}$			1	V
PHSIN Threshold Voltage	Compare to $V(V_{CCL})$	30	50	70	%
VDAC Buffer Amplifier					
Input Offset Voltage	$V(V_{DAC_BUFF}) - V(V_{DAC})$, $0.5V \leq V(V_{DAC}) \leq 1.6V$, $< 1\text{mA}$ load	-5	0	9	mV
Source Current	$0.5V \leq V(V_{DAC}) \leq 1.6V$	0.3	0.44	0.6	mA
Sink Current	$0.5V \leq V(V_{DAC}) \leq 1.6V$	3.5	13	20	mA
Unity Gain Bandwidth	Note 1		3.5		MHz
Slew Rate	Note 1		1.5		$V/\mu s$
Thermal Compensation Amplifier					
Output Offset Voltage	$0V \leq V(IIN) - V(V_{DAC}) \leq 1.6V$, $0.5V \leq V(V_{DAC}) \leq 1.6V$, $R_{eq}/R_2 = 2$	-10	0	10	mV
Source Current	$0.5V \leq V(V_{DAC}) \leq 1.6V$	3	8	15	mA
Sink Current	$0.5V \leq V(V_{DAC}) \leq 1.6V$	0.3	0.4	0.5	mA
Unity Gain Bandwidth	Note 1, $R_{eq}/R_2 = 2$	2	4.5	7	MHz
Slew Rate	Note 1		5.5		$V/\mu s$
Current Report Amplifier					
Output Offset Voltage	$V(V_{DRP}) - V(V_{DAC}) = 0, 225, 450, 900\text{mV}$	37	52	67	mV

PARAMETER	TEST CONDITION	MIN	TYP	MAX	UNIT
Source Current	$0.5V \leq V(IMON) \leq 0.9V$	5	9	15	mA
Sink Resistance	$0.5V \leq V(IMON) \leq 0.9V$	5	10	17	k Ω
Unity Gain Bandwidth	Note 1		1		MHz
Input Filter Time Constant			1		μ s
Max Output Voltage		1.04	1.09	1.145	V
Soft Start and Delay					
Start Delay (TD1)		1.0	2.9	3.5	ms
Soft Start Time (TD2)		0.8	2.2	3.25	ms
VID Sample Delay (TD3)		0.3	1.2	3.0	ms
PGOOD Delay (TD4 + TD5)		0.5	1.2	2.3	ms
OC Delay Time	$V(VDRP) - V(DACBUFF) = 1.67$ mV	75	125	300	us
SS/DEL to FB Input Offset Voltage	With FB = 0V, adjust V(SS/DEL) until EAOUT drives high	0.7	1.4	1.9	V
Charge Current		35.0	52.5	70.0	μ A
Discharge Current		2.5	4.5	6.5	μ A
Charge/Discharge Current Ratio		10	12	16	μ A/ μ A
Charge Voltage		3.6	4.0	4.2	V
Delay Comparator Threshold	Relative to Charge Voltage, SS/DEL rising	50	80	125	mV
Delay Comparator Threshold	Relative to Charge Voltage, SS/DEL falling	85	120	160	mV
Delay Comparator Input Filter			5		μ s
Delay Comparator Hysteresis		10	30	60	mV
VID Sample Delay Comparator Threshold		2.8	3.0	3.2	V
Discharge Comp. Threshold		150	200	275	mV
Remote Sense Differential Amplifier					
Unity Gain Bandwidth	Note 1	3.0	6.4	9.0	MHz
Input Offset Voltage	$0.5V \leq V(VOSEN+) - V(VOSEN-) \leq 1.6V$	-3	0	3	mV
Sink Current	$0.5V \leq V(VOSEN+) - V(VOSEN-) \leq 1.6V$	0.4	1	2	mA
Source Current	$0.5V \leq V(VOSEN+) - V(VOSEN-) \leq 1.6V$	3	9	20	mA
Slew Rate	$0.5V \leq V(VOSEN+) - V(VOSEN-) \leq 1.6V$	2	4	8	V/us
VOSEN+ Bias Current	$0.5V < V(VOSEN+) < 1.6V$			100	μ A
VOSEN- Bias Current	$-0.3V \leq VOSEN- \leq 0.3V$, All VID Codes		160	275	μ A
High Voltage	$V(VCCL) - V(VO)$	1.5	2	2.5	V
Low Voltage	$V(VCCL)=7V$			50	mV
Error Amplifier					
Input Offset Voltage	Measure $V(FB) - V(VSETPT)$. Note 2	-1	0	1	mV
FB Bias Current		-1	0	1	μ A
VSETPT Bias Current	Rosc= 24.5 K Ω	23.00	24.25	25.50	μ A
DC Gain	Note 1	100	110	120	dB
Bandwidth	Note 1	20	30	40	MHz
Slew Rate	Note 1	7	12	20	V/ μ s
Sink Current		0.40	0.85	1.00	mA
Source Current		5	8	12	mA
Maximum Voltage	Measure $V(VCCL) - V(EAOUT)$	500	780	950	mV

PARAMETER	TEST CONDITION	MIN	TYP	MAX	UNIT
Minimum Voltage			120	250	mV
Open Voltage Loop Detection Threshold	Measure V(VCCL) - V(EAOUT), Relative to Error Amplifier maximum voltage.	125	300	600	mV
Open Voltage Loop Detection Delay	Measure PHSOUT pulse numbers from V(EAOUT) = V(VCCL) to PGOOD = low.		8		Pulses
Enable Input					
VR 11 Threshold Voltage	ENABLE rising	825	850	875	mV
VR 11 Threshold Voltage	ENABLE falling	775	800	825	mV
VR 11 Hysteresis		25	50	75	mV
Bias Current	$0V \leq V(ENABLE) \leq 3.3V$	-5	0	5	μA
Blanking Time	Noise Pulse < 100ns will not register an ENABLE state change. Note 1	75	250	400	ns
Over-Current Comparator					
Input Offset Voltage	$1V \leq V(IIN) \leq 3.3V$	-40	-25	-10	mV
Input Filter Time Constant			2		μS
Over-Current Threshold	VDRP-VDAC_BUFF	1.07	1.17	1.27	V
Over-Current Delay Counter	ROSC = 7.75 K Ω (PHSOUT=1.5MHz)		4096		Cycle
Over-Current Delay Counter	ROSC = 15.0 K Ω (PHSOUT=800kHz)		2048		Cycle
Over-Current Delay Counter	ROSC = 50.0 K Ω (PHSOUT=250kHz)		1024		Cycle
Over-Current Limit Amplifier					
Input Offset Voltage		-10	0	10	mV
Transconductance	Note 1	0.50	1.00	1.75	mA/V
Sink Current		35	55	75	μA
Unity Gain Bandwidth	Note 1	0.75	2.00	3.00	kHz
Over Voltage Protection (OVP) Comparators					
Threshold at Power-up	Measure at 1.5V VCCLDRV	1.1	1.21	1.30	V
Threshold during Normal Operation	Compare to V(VDAC)	105	125	145	mV
OVP Release Voltage during Normal Operation	Compare to V(VDAC)	-13	3	20	mV
Threshold during Dynamic VID down		1.70	1.73	1.75	V
Dynamic VID Detect Comparator Threshold		25	50	75	mV
Propagation Delay to IIN	Measure time from V(VO) > V(VDAC) (250mV overdrive) to V(IIN) transition to > 0.9 * V(VCCL).		90	180	nS
IIN Pull-up Resistance			5	15	Ω
Propagation Delay to OVP	Measure time from V(VO) > V(VDAC) (250mV overdrive) to V(ROSC/OVP) transition to >1V.		90	180	nS
OVP High Voltage	Measure V(VCCL)-V(ROSC/OVP)	0		1.2	V
OVP Power-up High Voltage	ROSC = 7.75 K Ω . Measure V(VCCLDRV)-V(ROSC/OVP) @ 1.5V	.100	.240	.375	V
OVP Power-up High Voltage	ROSC = 24.5 K Ω . Measure V(VCCLDRV)-V(ROSC/OVP) @ 1.5V	0		0.2	

PARAMETER	TEST CONDITION	MIN	TYP	MAX	UNIT
PGOOD Output					
Output Voltage	I(PGOOD) = 4mA		150	300	mV
Leakage Current	V(PGOOD) = 5.5V		0	10	μA
Under Voltage Threshold-VO decreasing	Reference to VDAC	-350	-300	-250	mV
Under Voltage Threshold-VO increasing	Reference to VDAC	-290	-240	-190	mV
Under Voltage Threshold Hysteresis		25	60	95	mV
VCCL_DRV Activation Threshold	I(PG)=4mA, V(PG)<300mV, V(VCCL)=0	1	2	3.6	V
Open Sense Line Detection					
Sense Line Detection Active Comparator Threshold Voltage		150	200	250	mV
Sense Line Detection Active Comparator Offset Voltage	$V(VO) < [V(VOSEN+) - V(LGND)] / 2$	30	55	80	mV
VOSEN+ Open Sense Line Comparator Threshold	Compare to V(VCCL)	87.5	90.0	92.5	%
VOSEN- Open Sense Line Comparator Threshold		0.36	0.40	0.44	V
Sense Line Detection Source Currents	V(VO) = 100mV	200	500	700	μA
VRHOT Comparator					
Threshold Voltage		1.584	1.600	1.616	V
HOTSET Bias Current		-1	0	1	μA
Hysteresis		75	100	125	mV
Output Voltage	I(VRHOT) = 30mA		150	400	mV
VRHOT Leakage Current	V(VRHOT) = 5.5V		0	10	μA
VCCL Regulator Amplifier					
VCCL Output Voltage		6.568	6.8	7.031	V
VCCLDRV Sink Current		10	30		mA
UVLO Start Threshold	Compare to V(VCCL)	6.12	6.392	6.664	V
UVLO Stop Threshold	Compare to V(VCCL)	5.168	5.44	5.712	V
Hysteresis		0.85	0.95	1.05	V
General					
VCCL Supply Current		4	8	12	mA

Note 1: Guaranteed by design, but not tested in production

Note 2: VDAC Output is trimmed to compensate for Error Amplifier input offsets errors

PIN DESCRIPTION

PIN#	PIN SYMBOL	PIN DESCRIPTION
1-8	VID7-0	Inputs to VID D to A Converter.
9	ENABLE	Enable input. A logic low applied to this pin puts the IC into fault mode. Do not float this pin as the logic state will be undefined.
10	VRHOT	Open collector output of the VRHOT comparator which drives low if HOTSET pin voltage is lower than 1.6V. Connect external pull-up.
11	HOTSET	A resistor divider including thermistor senses the temperature, which is used for VRHOT comparator.
12	VOSEN-	Remote sense amplifier input. Connect to ground at the load.
13	VOSEN+	Remote sense amplifier input. Connect to output at the load.
14	VO	Remote sense amplifier output.
15	FB	Inverting input to the Error Amplifier.
16	EAOUT	Output of the error amplifier.
17	VDRP	Buffered, scaled and thermally compensated IIN signal. Connect an external RC network to FB to program converter output impedance.
18	VN	Node for DCR thermal compensation network.
19	VDAC_BUFF	Buffered VDAC.
20	VSETPT	Error amplifier non-inverting input. Converter output voltage can be decreased from the VDAC voltage with an external resistor connected between VDAC and this pin (there is an internal sink current at this pin).
21	VDAC	Regulated voltage programmed by the VID inputs. Connect an external RC network to LGND to program dynamic VID slew rate and provide compensation for the internal buffer amplifier.
22	SS/DEL	Programs converter startup and over current protection delay timing. It is also used to compensate the constant output current loop during soft start. Connect an external capacitor to LGND to program.
23	ROSC/OVP	Connect a resistor to LGND to program oscillator frequency and OCSET, VSETPT and VDAC bias currents. Oscillator frequency equals switching frequency per phase. The pin voltage is 0.6V during normal operation and higher than 1.6V if an over-voltage condition is detected.
24	LGND	Local Ground for internal circuitry and IC substrate connection.
25	CLKOUT	Clock output at switching frequency multiplied by phase number. Connect to CLKIN pins of phase ICs.
26	PHSOUT	Phase clock output at switching frequency per phase. Connect to PHSIN pin of the first phase IC.
27	PHSIN	Feedback input of phase clock. Connect to PHSOUT pin of the last phase IC.
28	VCCL	Voltage regulator and IC power input. Connect a decoupling capacitor to LGND.
29	IIN	Average current input from the phase IC(s). This pin is also used to communicate over voltage condition to phase ICs.
30	VCCLDRV	Output of the VCCL regulator error amplifier to control external transistor. The pin senses 12V power supply through a resistor.
31	PGOOD	Open collector output that drives low during startup and under any external fault condition. Indicates converter within regulation. Connect external pull-up.
32	IMON	Voltage at IOUT pin will be proportional to load current.

SYSTEM THEORY OF OPERATION

System Description

The system consists of one control IC and a scalable array of phase converters, each requiring one phase IC. The control IC communicates with the phase ICs using three digital buses, i.e., CLOCK, PHSIN, PHSOUT and three analog buses, i.e., VDAC, EA, IIN. The digital buses are responsible for switching frequency determination and accurate phase timing control without any external component. The analog buses are used for PWM control and current sharing among interleaved phases. The control IC incorporates all the system functions, i.e., VID, CLOCK signals, error amplifier, fault protections, current monitor, etc. The Phase IC implements the functions required by each phase of the converter, i.e., the gate drivers, PWM comparator and latch, over-voltage protection, Phase disable circuit, current sensing and sharing, etc.

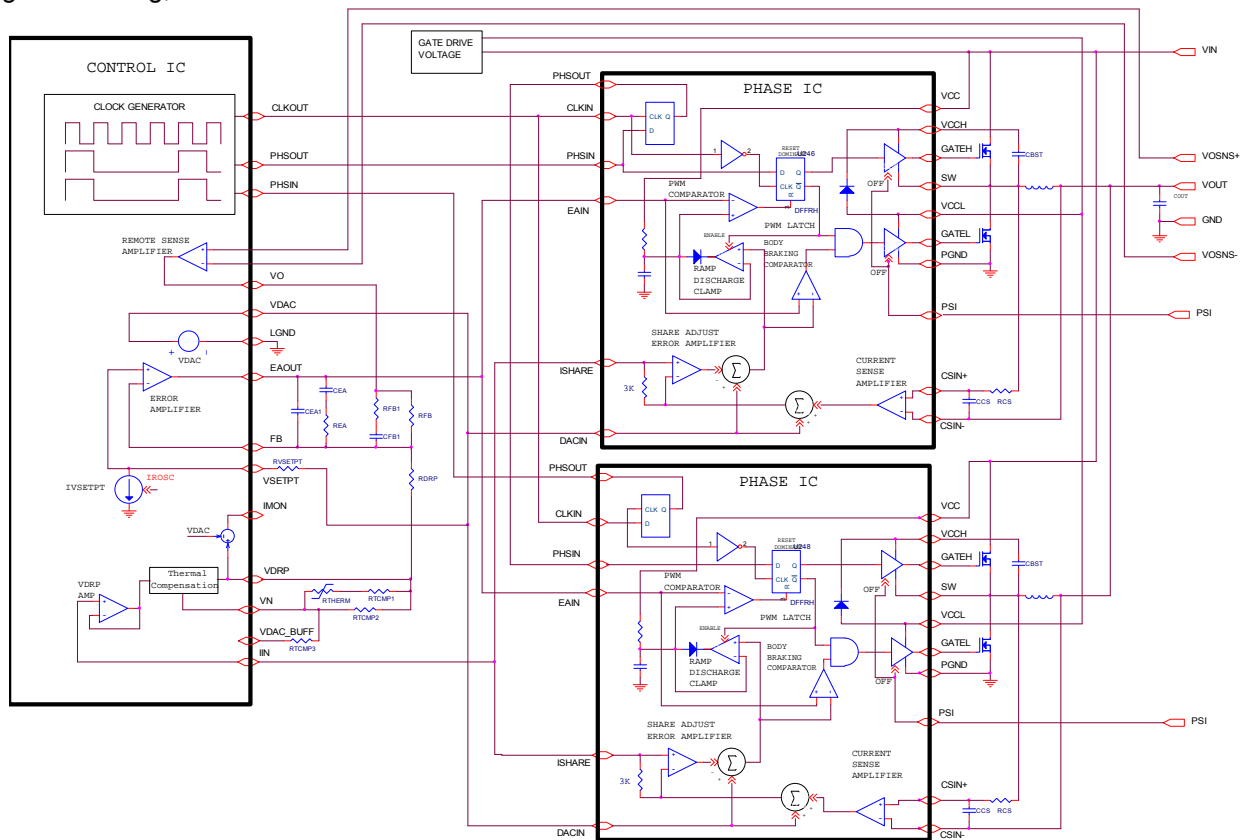

Figure 3 System Block Diagram

PWM Control Method

The PWM block diagram of the *XPhase*³TM architecture is shown in Figure 3. Feed-forward voltage mode control with trailing edge modulation is used. A high-gain wide-bandwidth voltage type error amplifier in the control IC is used for the voltage control loop. Input voltage is sensed in phase ICs and feed-forward control is realized. The PWM ramp slope will change with the input voltage and automatically compensate for changes in the input voltage. The input voltage can change due to variations in the silver box output voltage or due to the wire and PCB-trace voltage drop related to changes in load current.

Frequency and Phase Timing Control

The oscillator is located in the control IC and the system clock frequency is programmable from 250kHz to 9MHz by an external resistor. The control IC system clock signal CLKOUT is connected to CLKIN of all the phase ICs. The phase timing of the phase ICs is controlled by the daisy chain loop, where control IC phase clock output PHSOUT is

connected to the phase clock input PHSIN of the first phase IC, and PHSOUT of the first phase IC is connected to PHSIN of the second phase IC, etc. The PHSOUT of the last phase IC is connected back to PHSIN of the control IC.

During power up, the control IC sends out clock signals from both CLKOUT and PHSOUT pins and detects the feedback at PHSIN pin to determine the phase number and monitor any fault in the daisy chain loop. Figure 4 shows the phase timing for a four phase converter. The switching frequency is set by the resistor ROSC. The clock frequency equals the number of phase times the switching frequency.

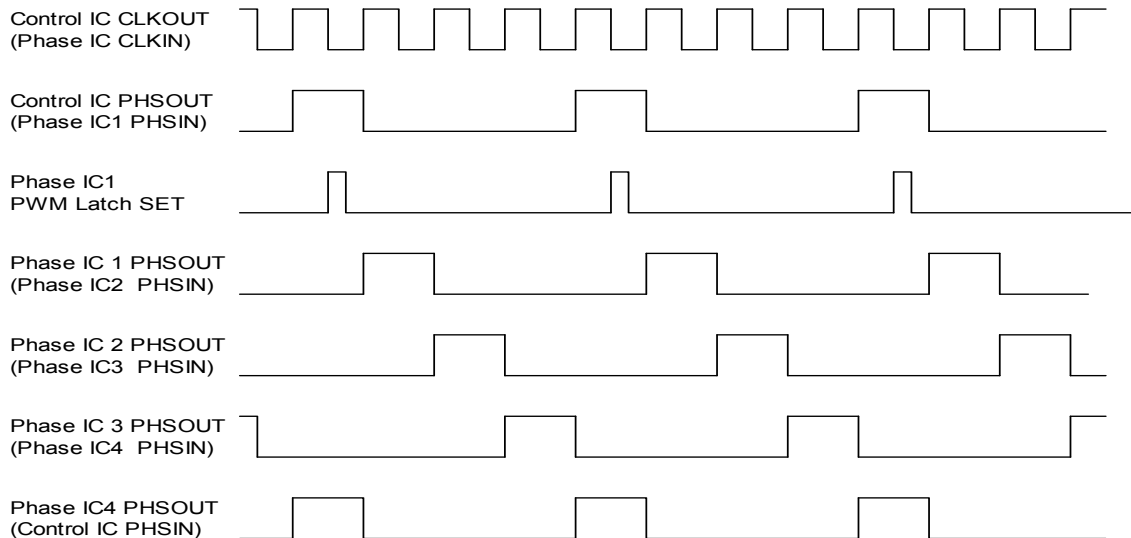

Figure 4 Four Phase Oscillator Waveforms

PWM Operation

The PWM comparator is located in the phase IC. With the PHSIN voltage high, upon receiving the falling edge of a clock pulse, the PWM latch is set. The PWMRMP voltage begins to increase; the low side driver is turned off, and the high side driver is turned on after the non-overlap time. When the PWMRMP voltage exceeds the error amplifier's output voltage, the PWM latch is reset. This turns off the high side driver and then turns on the low side driver after the non-overlap time. Along with that, it activates the ramp discharge clamp, which quickly discharges the PWMRMP capacitor to the output voltage of share adjust amplifier in phase IC until the next clock pulse.

The PWM latch is reset dominant allowing all phases to go to zero duty cycle within a few tens of nanoseconds in response to a load step decrease. Phases can overlap and go up to 100% duty cycle in response to a load step increase with turn-on gated by the clock pulses. An error amplifier output voltage greater than the common mode input range of the PWM comparator results in 100% duty cycle regardless of the voltage of the PWM ramp. This arrangement guarantees the error amplifier is always in control and can demand 0 to 100% duty cycle as required. It also favors response to a load step decrease which is appropriate, given the low output to input voltage ratio of most systems. The inductor current will increase much more rapidly than decrease in response to load transients. The error amplifier is a high speed amplifier with wide bandwidth and fast slew rate incorporated in the control IC. It is not unity gain stable.

This control method is designed to provide "single cycle transient response," where the inductor current changes in response to load transients within a single switching cycle maximizing the effectiveness of the power train and minimizing the output capacitor requirements. An additional advantage of the architecture is that differences in the ground or input voltage at the phases have no effect on operation since the PWM ramps are referenced to VDAC. Figure 5 depicts PWM operating waveforms under various conditions.

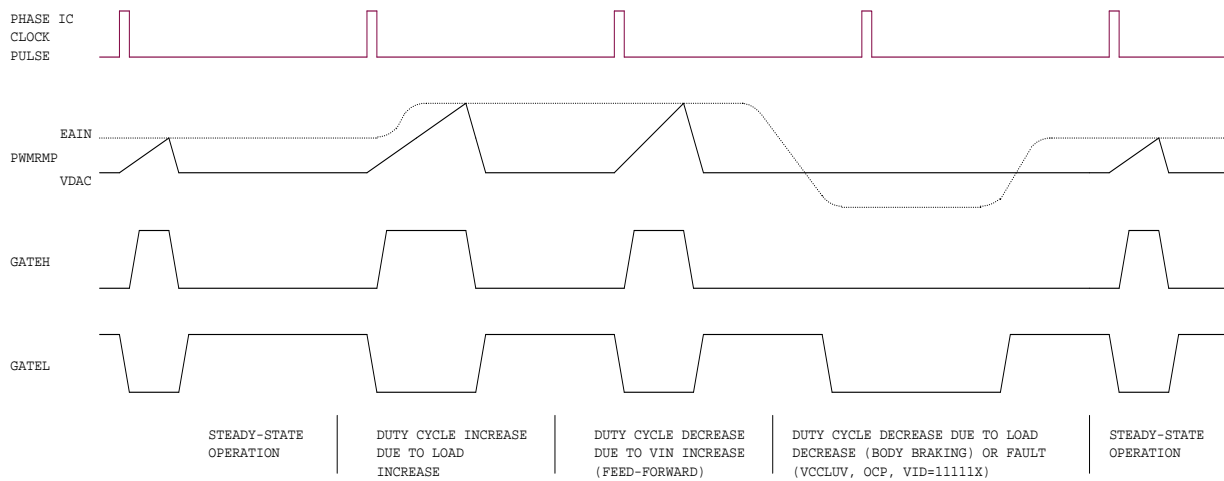

Figure 5 PWM Operating Waveforms

Body Braking™

In a conventional synchronous buck converter, the minimum time required to reduce the current in the inductor in response to a load step decrease is;

$$T_{SLEW} = \frac{L * (I_{MAX} - I_{MIN})}{V_O}$$

The slew rate of the inductor current can be significantly increased by turning off the synchronous rectifier in response to a load step decrease. The switch node voltage is then forced to decrease until conduction of the synchronous rectifier's body diode occurs. This increases the voltage across the inductor from V_{out} to $V_{out} + V_{BODYDIODE}$. The minimum time required to reduce the current in the inductor in response to a load transient decrease is now;

$$T_{SLEW} = \frac{L * (I_{MAX} - I_{MIN})}{V_O + V_{BODYDIODE}}$$

Since the voltage drop in the body diode is often comparable to the output voltage, the inductor current slew rate can be increased significantly. This patented technique is referred to as "body braking" and is accomplished through the "body braking comparator" located in the phase IC. If the error amplifier's output voltage drops below the output voltage of the share adjust amplifier in the phase IC, this comparator turns off the low side gate driver, enabling the bottom FET body diode to take over. There is 100mV upslope and 200mV down slope hysteresis for the body braking comparator.

Lossless Average Inductor Current Sensing

Inductor current can be sensed by connecting a series resistor and a capacitor network in parallel with the inductor and measuring the voltage across the capacitor, as shown in Figure 6. The equation of the sensing network is,

$$v_C(s) = v_L(s) \frac{1}{1 + sR_{CS}C_{CS}} = i_L(s) \frac{R_L + sL}{1 + sR_{CS}C_{CS}}$$

Usually the resistor R_{cs} and capacitor C_{cs} are chosen, such that, the time constant of R_{cs} and C_{cs} equals the time constant of the inductor, which is the inductance L over the inductor DCR R_L . If the two time constants match, the voltage across C_{cs} is proportional to the current through L , and the sense circuit can be treated as if only a sense

resistor with the value of R_L was used. The mismatch of the time constants does not affect the measurement of inductor DC current, but affects the AC component of the inductor current.

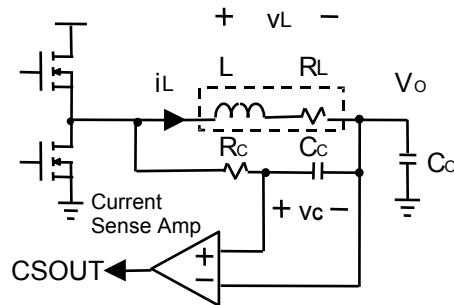

Figure 6 Inductor Current Sensing and Current Sense Amplifier

The advantage of sensing the inductor current versus high side or low side sensing is that actual output current being delivered to the load is obtained rather than peak or sampled information about the switch currents. The output voltage can be positioned to meet a load line based on real time information. Except for a sense resistor in series with the inductor, this is the only sense method that can support a single cycle transient response. Other methods provide no information during either load increase (low side sensing) or load decrease (high side sensing).

An additional problem associated with peak or valley current mode control for voltage positioning is that they suffer from peak-to-average errors. These errors will show in many ways but one example is the effect of frequency variation. If the frequency of a particular unit is 10% low, the peak to peak inductor current will be 10% larger and the output impedance of the converter will drop by about 10%. Variations in inductance, current sense amplifier bandwidth, PWM prop delay, any added slope compensation, input voltage, and output voltage are all additional sources of peak-to-average errors.

Current Sense Amplifier

A high speed differential current sense amplifier is located in the phase IC, as shown in Figure 6. Its gain is nominally 33 at 25°C, and the 3850 ppm/°C increase in inductor DCR should be compensated in the voltage loop feedback path.

The current sense amplifier can accept positive differential input up to 50mV and negative up to -10mV before clipping. The output of the current sense amplifier is summed with the VDAC voltage and sent to the control IC and other phases through an on-chip 3KΩ resistor connected to the IIN pin. The IIN pins of all the phases are tied together and the voltage on the share bus represents the average current through all the inductors and is used by the control IC for voltage positioning and current limit protection. The input offset of this amplifier is calibrated to +/- 1mV in order to reduce the current sense error.

The input offset voltage is the primary source of error for the current share loop. In order to achieve very small input offset error and superior current sharing performance, the current sense amplifier continuously calibrates itself. This calibration algorithm creates ripple on IIN bus with a frequency of $f_{sw}/(32*28)$ in a multiphase architecture.

Average Current Share Loop

Current sharing between the phases of the converter is achieved by the average current share loop in each phase IC. The output of the current sense amplifier is compared with average current at the share bus. If current in a phase is smaller than the average current, the share adjust amplifier of the phase will pull down the starting point of the PWM ramp thereby increasing its duty cycle and output current; if current in a phase is larger than the average current, the share adjust amplifier of the phase will pull up the starting point of the PWM ramp thereby decreasing its duty cycle and output current. The current share amplifier is internally compensated; such that, the crossover frequency of the current share loop is much slower than that of the voltage loop and the two loops do not interact.

IR3502A THEORY OF OPERATION

Block Diagram

The block diagram of the IR3502A is shown in Figure 7.

VID Control

The control IC allows the processor voltage to be set by a parallel eight bit digital VID bus. The VID codes set the VDAC as shown in Table 1. The VID pins require an external bias voltage and should not be floated. The VID input comparators monitor the VID pins and control the Digital-to-Analog Converter (DAC), whose output is sent to the VDAC buffer amplifier. The output of the buffer amplifier is the VDAC pin. The VDAC voltage, input offsets of error amplifier and remote sense differential amplifier are post-package trimmed to achieve 0.5% system set-point accuracy for VID range between 1V to 1.6V. A set-point accuracy of $\pm 5\text{mV}$ and $\pm 8\text{mV}$ is achieved for VID ranges of 0.8V-1V and 0.5V-0.8V respectively. The actual VDAC voltage does not determine the system accuracy, which has a wider tolerance.

The IR3502A can accept changes in the VID code while operating and vary the VDAC voltage accordingly. The slew rate of the voltage at the VDAC pin can be adjusted by an external capacitor between VDAC pin and LGND pin. A resistor connected in series with this capacitor is required to compensate the VDAC buffer amplifier. Digital VID transitions result in a smooth analog transition of the VDAC voltage and converter output voltage minimizing inrush currents in the input and output capacitors and overshoot of the output voltage.

Adaptive Voltage Positioning

Adaptive voltage positioning is needed to optimize the output voltage deviations during load transients and the power dissipation of the load at heavy load. The circuitry related to voltage positioning is shown in Figure 8. The output voltage is set by the reference voltage VSETPT at the positive input to the error amplifier. This reference voltage can be programmed to have a constant DC offset below the VDAC by connecting RSETPT between VDAC and VSETPT. The IVSETPT is controlled by the ROSC.

The average load current information for all the phases is fed back to the control IC through the IIN pin. As shown in Figure 8, this information is thermally compensated with some gain by a set of buffer and thermal compensation amplifiers to generate the voltage at the VDRP pin. The VDRP pin is connected to the FB pin through the resistor RDRP. Since the error amplifier will force the loop to maintain FB to be equal to the VDAC reference voltage, an additional current will flow into the FB pin equal to $(\text{VDRP}-\text{VDAC}) / \text{RDRP}$. When the load current increases, the VDRP voltage increases accordingly. More current flows through the feedback resistor RFB and causes the output to have more droop. The positioning voltage can be programmed by the resistor RDRP so that the droop impedance produces the desired converter output impedance. The offset and slope of the converter output impedance are referenced to and therefore independent of the VDAC voltage.

Inductor DCR Temperature Compensation

A negative temperature coefficient (NTC) thermistor should be used for inductor DCR temperature compensation. The thermistor and tuning resistor network connected between the VN and VDRP pins provides a single NTC thermal compensation. The thermistor should be placed close to the power stage to accurately reflect the thermal performance of the inductor DCR. The resistor in series with the thermistor is used to reduce the nonlinearity of the thermistor.

Remote Voltage Sensing

VOSEN+ and VOSEN- are used for remote sensing and connected directly to the load. The remote sense differential amplifier with high speed, low input offset and low input bias current ensures accurate voltage sensing and fast transient response. There is finite input current at both pins VOSEN+ and VOSEN- due to the internal resistor of the differential amplifier. This limits the size of the resistors that can be used in series with these pins for acceptable regulation of the output voltage.

TABLE 1 VR11 VID TABLE (PART1)

Hex (VID7:VID0)	Dec (VID7:VID0)	Voltage
00	00000000	Fault
01	00000001	Fault
02	00000010	1.60000
03	00000011	1.59375
04	00000100	1.58750
05	00000101	1.58125
06	00000110	1.57500
07	00000111	1.56875
08	00001000	1.56250
09	00001001	1.55625
0A	00001010	1.55000
0B	00001011	1.54375
0C	00001100	1.53750
0D	00001101	1.53125
0E	00001110	1.52500
0F	00001111	1.51875
10	00010000	1.51250
11	00010001	1.50625
12	00010010	1.50000
13	00010011	1.49375
14	00010100	1.48750
15	00010101	1.48125
16	00010110	1.47500
17	00010111	1.46875
18	00011000	1.46250
19	00011001	1.45625
1A	00011010	1.45000
1B	00011011	1.44375
1C	00011100	1.43750
1D	00011101	1.43125
1E	00011110	1.42500
1F	00011111	1.41875
20	00100000	1.41250
21	00100001	1.40625
22	00100010	1.40000
23	00100011	1.39375
24	00100100	1.38750
25	00100101	1.38125
26	00100110	1.37500
27	00100111	1.36875
28	00101000	1.36250
29	00101001	1.35625
2A	00101010	1.35000
2B	00101011	1.34375
2C	00101100	1.33750
2D	00101101	1.33125
2E	00101110	1.32500
2F	00101111	1.31875
30	00110000	1.31250
31	00110001	1.30625
32	00110010	1.30000
33	00110011	1.29375
34	00110100	1.28750
35	00110101	1.28125
36	00110110	1.27500
37	00110111	1.26875
38	00111000	1.26250
39	00111001	1.25625
3A	00111010	1.25000
3B	00111011	1.24375
3C	00111100	1.23750
3D	00111101	1.23125
3E	00111110	1.22500
3F	00111111	1.21875

Hex (VID7:VID0)	Dec (VID7:VID0)	Voltage
40	01000000	1.21250
41	01000001	1.20625
42	01000010	1.20000
43	01000011	1.19375
44	01000100	1.18750
45	01000101	1.18125
46	01000110	1.17500
47	01000111	1.16875
48	01001000	1.16250
49	01001001	1.15625
4A	01001010	1.15000
4B	01001011	1.14375
4C	01001100	1.13750
4D	01001101	1.13125
4E	01001110	1.12500
4F	01001111	1.11875
50	01010000	1.11250
51	01010001	1.10625
52	01010010	1.10000
53	01010011	1.09375
54	01010100	1.08750
55	01010101	1.08125
56	01010110	1.07500
57	01010111	1.06875
58	01011000	1.06250
59	01011001	1.05625
5A	01011010	1.05000
5B	01011011	1.04375
5C	01011100	1.03750
5D	01011101	1.03125
5E	01011110	1.02500
5F	01011111	1.01875
60	01100000	1.01250
61	01100001	1.00625
62	01100010	1.00000
63	01100011	0.99375
64	01100100	0.98750
65	01100101	0.98125
66	01100110	0.97500
67	01100111	0.96875
68	01101000	0.96250
69	01101001	0.95625
6A	01101010	0.95000
6B	01101011	0.94375
6C	01101100	0.93750
6D	01101101	0.93125
6E	01101110	0.92500
6F	01101111	0.91875
70	01110000	0.91250
71	01110001	0.90625
72	01110010	0.90000
73	01110011	0.89375
74	01110100	0.88750
75	01110101	0.88125
76	01110110	0.87500
77	01110111	0.86875
78	01111000	0.86250
79	01111001	0.85625
7A	01111010	0.85000
7B	01111011	0.84375
7C	01111100	0.83750
7D	01111101	0.83125
7E	01111110	0.82500
7F	01111111	0.81875

TABLE 1 VR11 VID TABLE (PART 2)

Hex (VID7:VID0)	Dec (VID7:VID0)	Voltage
80	10000000	0.81250
81	10000001	0.80625
82	10000010	0.80000
83	10000011	0.79375
84	10000100	0.78750
85	10000101	0.78125
86	10000110	0.77500
87	10000111	0.76875
88	10001000	0.76250
89	10001001	0.75625
8A	10001010	0.75000
8B	10001011	0.74375
8C	10001100	0.73750
8D	10001101	0.73125
8E	10001110	0.72500
8F	10001111	0.71875
90	10010000	0.71250
91	10010001	0.70625
92	10010010	0.70000
93	10010011	0.69375
94	10010100	0.68750
95	10010101	0.68125
96	10010110	0.67500
97	10010111	0.66875
98	10011000	0.66250
99	10011001	0.65625
9A	10011010	0.65000
9B	10011011	0.64375
9C	10011100	0.63750
9D	10011101	0.63125
9E	10011110	0.62500
9F	10011111	0.61875
A0	10100000	0.61250
A1	10100001	0.60625
A2	10100010	0.60000
A3	10100011	0.59375
A4	10100100	0.58750
A5	10100101	0.58125
A6	10100110	0.57500
A7	10100111	0.56875
A8	10101000	0.56250
A9	10101001	0.55625
AA	10101010	0.55000
AB	10101011	0.54375
AC	10101100	0.53750
AD	10101101	0.53125
AE	10101110	0.52500
AF	10101111	0.51875
B0	10110000	0.51250
B1	10110001	0.50625
B2	10110010	0.50000
B3	10110011	n/a
B4	10110100	n/a
B5	10110101	n/a
B6	10110110	n/a
B7	10110111	n/a
B8	10111000	n/a
B9	10111001	n/a
BA	10111010	n/a
BB	10111011	n/a
BC	10111100	n/a
BD	10111101	n/a
BE	10111110	n/a
BF	10111111	n/a

Hex (VID7:VID0)	Dec (VID7:VID0)	Voltage
C0	11000000	n/a
C1	11000001	n/a
C2	11000010	n/a
C3	11000011	n/a
C4	11000100	n/a
C5	11000101	n/a
C6	11000110	n/a
C7	11000111	n/a
C8	11001000	n/a
C9	11001001	n/a
CA	11001010	n/a
CB	11001011	n/a
CC	11001100	n/a
CD	11001101	n/a
CE	11001110	n/a
CF	11001111	n/a
D0	11010000	n/a
D1	11010001	n/a
D2	11010010	n/a
D3	11010011	n/a
D4	11010100	n/a
D5	11010101	n/a
D6	11010110	n/a
D7	11010111	n/a
D8	11011000	n/a
D9	11011001	n/a
DA	11011010	n/a
DB	11011011	n/a
DC	11011100	n/a
DD	11011101	n/a
DE	11011110	n/a
DF	11011111	n/a
E0	11100000	n/a
E1	11100001	n/a
E2	11100010	n/a
E3	11100011	n/a
E4	11100100	n/a
E5	11100101	n/a
E6	11100110	n/a
E7	11100111	n/a
E8	11101000	n/a
E9	11101001	n/a
EA	11101010	n/a
EB	11101011	n/a
EC	11101100	n/a
ED	11101101	n/a
EE	11101110	n/a
EF	11101111	n/a
F0	11110000	n/a
F1	11110001	n/a
F2	11110010	n/a
F3	11110011	n/a
F4	11110100	n/a
F5	11110101	n/a
F6	11110110	n/a
F7	11110111	n/a
F8	11111000	n/a
F9	11111001	n/a
FA	11111010	n/a
FB	11111011	n/a
FC	11111100	n/a
FD	11111101	n/a
FE	11111110	FAULT
FF	11111111	FAULT

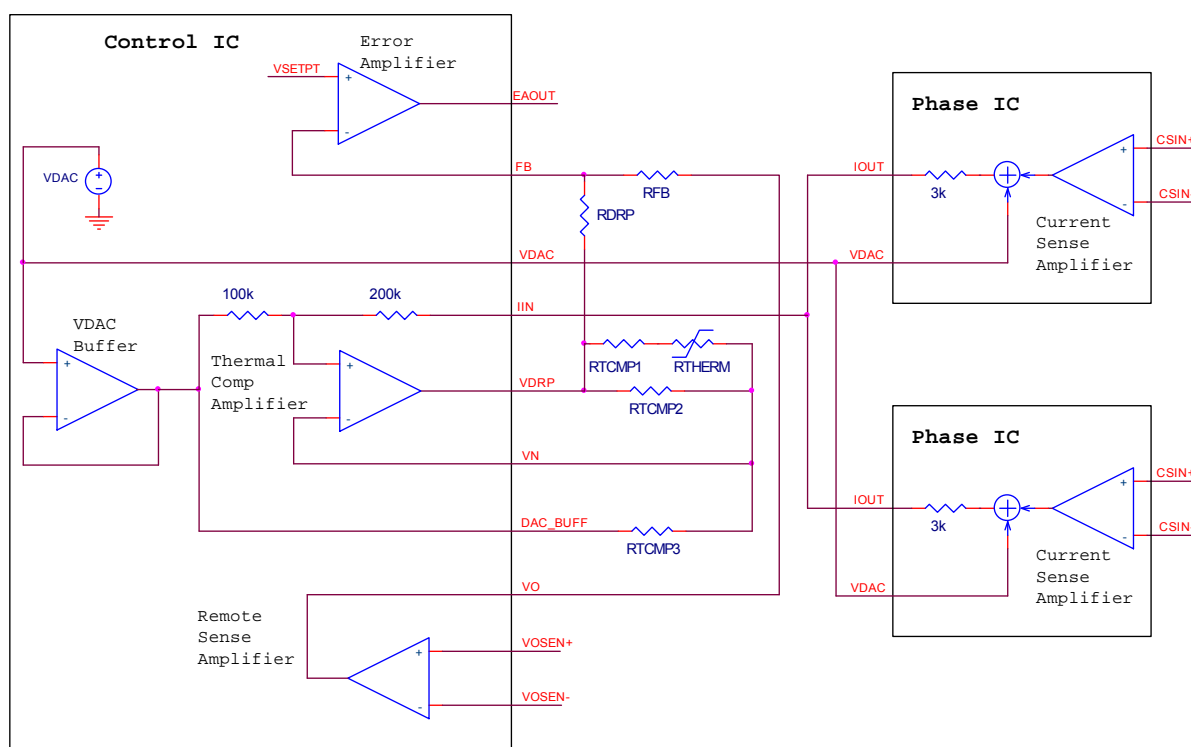

Figure 8 Adaptive voltage positioning with thermal compensation.

Start-up Sequence

The IR3502A has a programmable soft-start function to limit the surge current during the converter start-up. A capacitor connected between the SS/DEL and LGND pins controls soft start timing, over-current protection delay and hiccup mode timing. A charge current of 52.5uA and discharge current of 4uA control the up slope and down slope of the voltage at the SS/DEL pin respectively. Figure 9 depicts start-up sequence of converter with VR 11.1 VID. If there is no fault, as the ENABLE is asserted, the SS/DEL pin will start charging. The error amplifier output EAOUT is clamped low until SS/DEL reaches 1.4V. The error amplifier will then regulate the converter's output voltage to match the SS/DEL voltage less the 1.4V offset until the converter output reaches the 1.1V boot voltage. The SS/DEL voltage continues to increase until it rises above the 3.0V threshold of VID delay comparator. The VID set inputs are then activated and VDAC pin transitions to the level determined by the VID inputs. The SS/DEL voltage continues to increase until it rises above 3.92V and allows the PGOOD signal to be asserted. SS/DEL finally settles at 4.0V, indicating the end of the soft start. The remote sense amplifier has a very low operating range of 50 mV in order to achieve a smooth soft start of output voltage without bump.

The VCCL under voltage lock-out, VID fault modes, over current, as well as a low signal on the ENABLE input immediately sets the fault latch, which causes the EAOUT pin to drive low turning off the phase IC drivers. The PGOOD pin also drives low and SS/DEL begin to discharge until the voltage reaches 0.2V. If the fault has cleared the fault latch will be reset by the discharge comparator allowing a normal soft start to occur.

Other fault conditions, such as over voltage, open sense lines, open loop monitor, and open daisy chain, set different fault latches, which start discharging SS/DEL, pull down EAOUT voltage and drive PGOOD low. However, the latches can only be reset by cycling VCCL power.

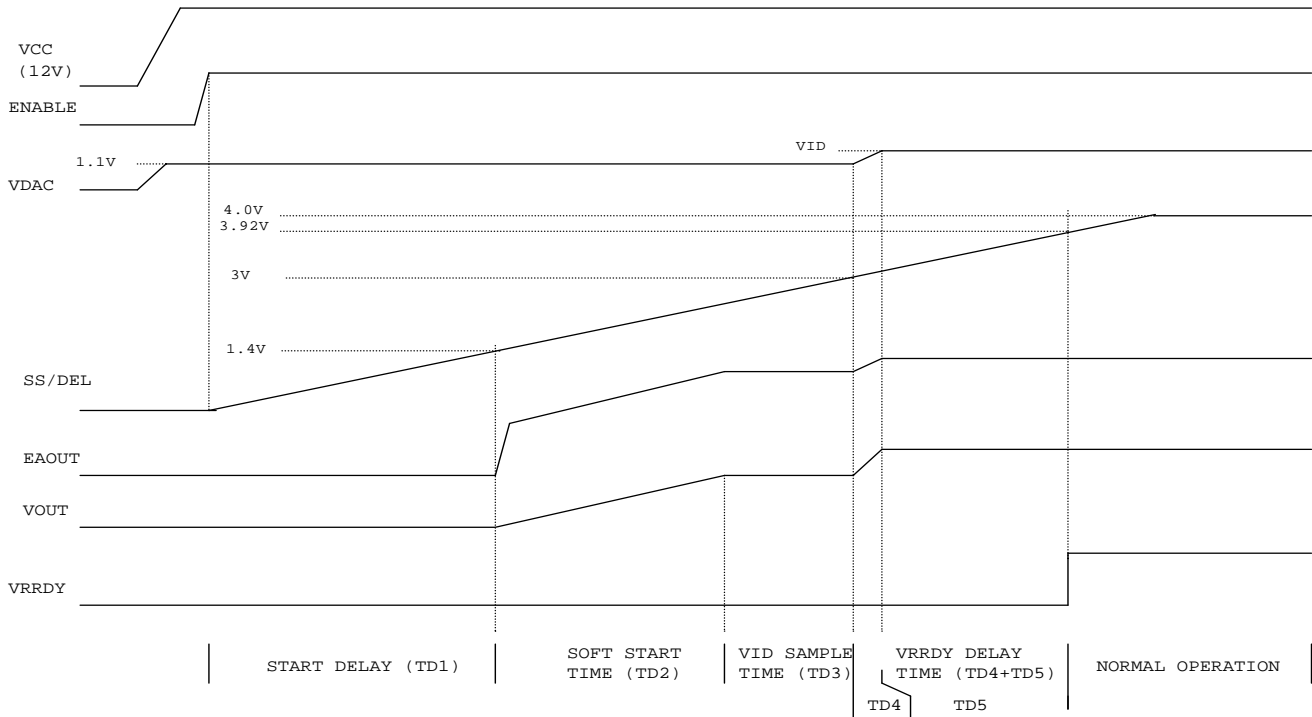

Figure 9 Start-up sequence of converter with boot voltage

Current Monitor (IMON)

The control IC generates a current monitor signal IMON using the VDRP voltage and the VDAC reference, as shown in Figure 10. This voltage is thermally compensated for the inductor DCR variation. The voltage at this pin reports the average load current information without being referenced to VDAC. The slope of the IMON signal with respect to the load current can be adjusted with the resistors RTCMP2 and RTCMP3. The IMON signal is clamped at 1.03V in order to facilitate direct interfacing with the CPU.

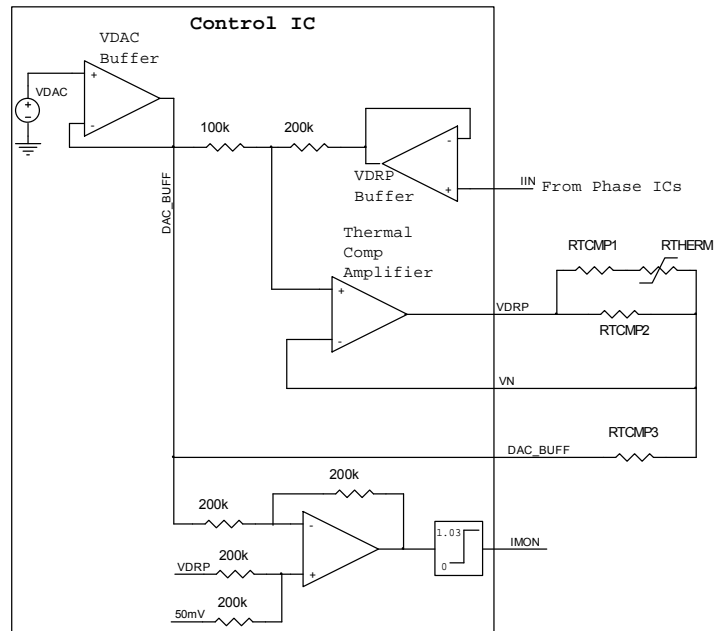

Figure 10 Current report signal (IMON) implementation

Constant Over-Current Control during Soft Start

The over current limit is fixed by 1.17V above the VDAC. If the VDRP pin voltage, which is proportional to the average current plus VDAC voltage, exceeds (VDAC+1.17V) during soft start, the constant over-current control is activated. Figure 11 shows the constant over-current control with delay during soft start. The delay time is set by the ROSC resistor, which sets the number of switching cycles for the delay counter. The delay is required since over-current conditions can occur as part of normal operation due to inrush current. If an over-current occurs during soft start (before PGOOD is asserted), the SS/DEL voltage is regulated by the over current amplifier to limit the output current below the threshold set by OC limit voltage. If the over-current condition persists after delay time is reached, the fault latch will be set pulling the error amplifier's output low and inhibiting switching in the phase ICs. The SS/DEL capacitor will discharge until it reaches 0.2V and the fault latch is reset allowing a normal soft start to occur. If an over-current condition is again encountered during the soft start cycle, the constant over-current control actions will repeat and the converter will be in hiccup mode. The delay time is controlled by a counter which is triggered by clock. The counter values vary with switching frequency per phase in order to have a similar delay time for different switching frequencies.

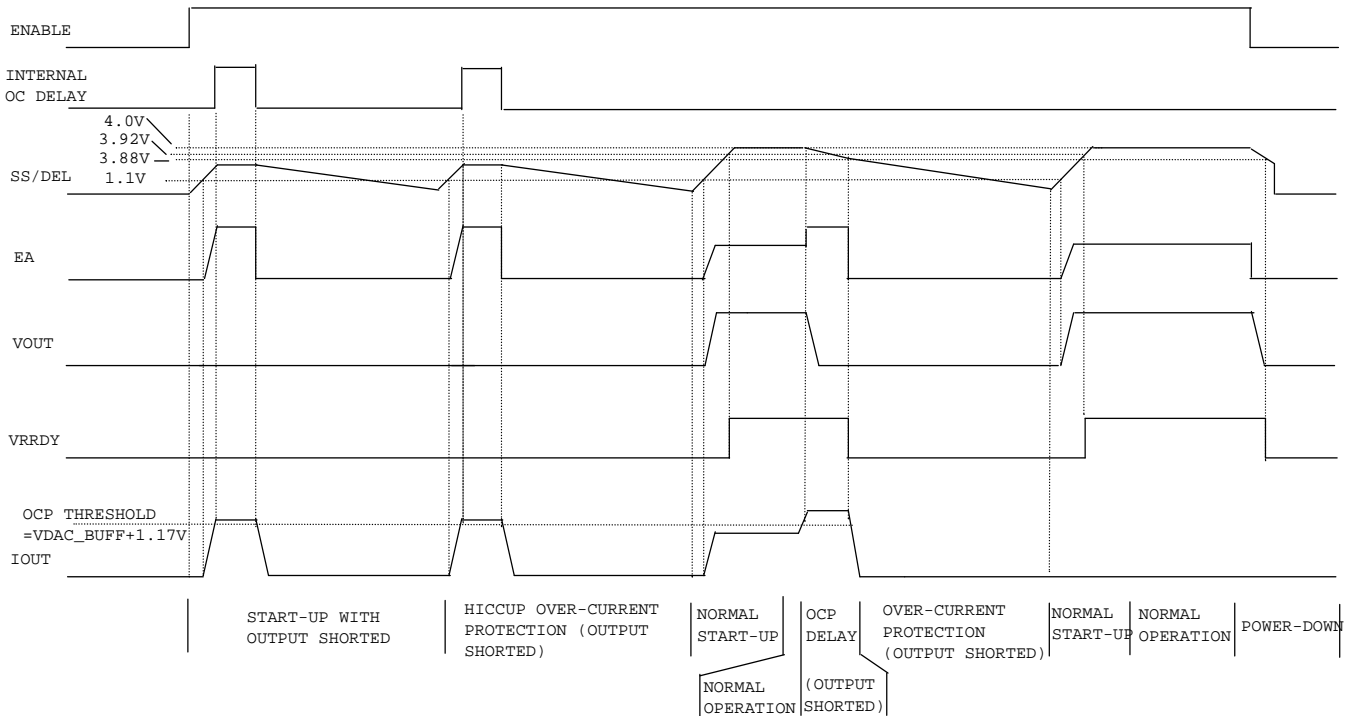

Figure 11 Constant over-current control waveforms during and after soft start.

Over-Current Hiccup Protection after Soft Start

The over current limit is fixed at 1.17V above the VDAC. Figure 11 shows the constant over-current control with delay after PGOOD is asserted. The delay is required since over-current conditions can occur as part of normal operation due to load transients or VID transitions.

If the VDRP pin voltage, which is proportional to the average current plus VDAC voltage, exceeds (VDAC+1.17V) after PGOOD is asserted, it will initiate the discharge of the capacitor at SS/DEL. The magnitude of the discharge current is proportional to the voltage difference between VDRP and (VDAC+1.17V) and has a maximum nominal value of 55uA. If the over-current condition persists long enough for the SS/DEL capacitor to discharge below the 120mV offset of the delay comparator, the fault latch will be set pulling the error amplifier's output low and inhibiting switching in the phase ICs and de-asserting the PGOOD signal. The output current is not controlled during the delay time. The SS/DEL capacitor will discharge until it reaches 200 mV and the fault latch is reset allowing a normal soft

start to occur. If an over-current condition is again encountered during the soft start cycle, the over-current action will repeat and the converter will be in hiccup mode.

Linear Regulator Output (VCCL)

The IR3502A has a built-in linear regulator controller, and only an external NPN transistor is needed to create a linear regulator. The voltage of VCCL is fixed at 6.8V with the feedback resistive divider internal to the IC. The regulator output powers the gate drivers of the phase ICs and circuits in the control IC, and the voltage is usually programmed to optimize the converter efficiency. The linear regulator can be compensated by a 4.7 μ F capacitor at the VCCL pin. As with any linear regulator, due to stability reasons, there is an upper limit to the maximum value of capacitor that can be used at this pin and it's a function of the number of phases used in the multiphase architecture and their switching frequency. Figure 12 shows the stability plots for the linear regulator with 5 phases switching at 750 kHz.

VCCL Under Voltage Lockout (UVLO)

The IR3502A has no under voltage lockout for converter input voltage (VCC), but monitors the VCCL voltage instead, which is used for the gate drivers of phase ICs and circuits in control IC and phase ICs. During power up, the fault latch will be reset if VCCL is above 94% of 6.8V. If VCCL voltage drops below 80% of 6.8V, the fault latch will be set.

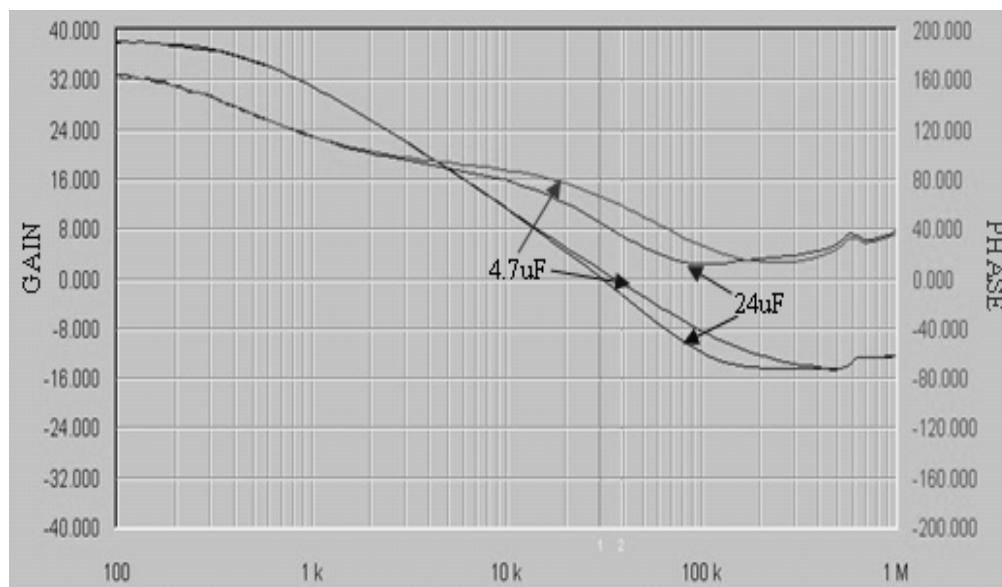

Figure 12 VCCL regulator stability with 5 phases and PHSOUT equals 750 kHz.

Over Voltage Protection (OVP)

Output over-voltage happens during normal operation if a high side MOSFET short occurs or if output voltage is out of regulation. The over-voltage protection comparator monitors VO pin voltage. If VO pin voltage exceeds VDAC by 130mV after SS, as shown in Figure 13, IR3502A raises ROSC/OVP pin voltage above to $V(VCCL) - 1V$, which sends over voltage signal to system. During startup, the threshold is 130 mV above last VID and reverts back to $VBOOT+130mV$ during boot mode. The ROSC/OVP pin can also be connected to a thyristor in a crowbar circuit, which pulls the converter input low in over voltage conditions. The over voltage condition also sets the over voltage fault latch, which pulls error amplifier output low to turn off the converter output. At the same time IIN pin (IIN of phase ICs) is pulled up to VCCL to communicate the over voltage condition to phase ICs, as shown in Figure 13. In each phase IC, the OVP circuit overrides the normal PWM operation and will fully turn-on the low side MOSFET within approximately 150ns. The low side MOSFET will remain on until IIN pin voltage drops below $V(VCCL) - 800mV$, which signals the end of over voltage condition. An over voltage fault condition is latched in the IR3502A and can only be cleared by cycling power to the IR3502A VCCL.

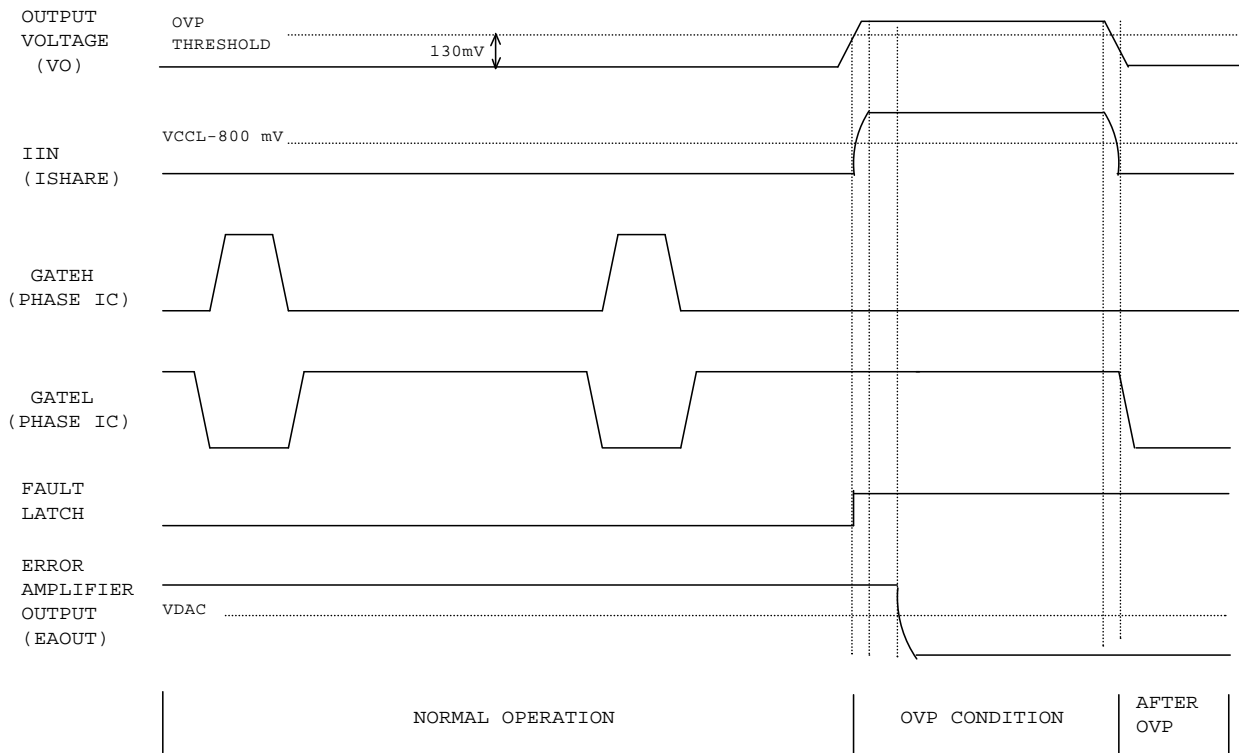

Figure 13 Over-voltage protection during normal operation

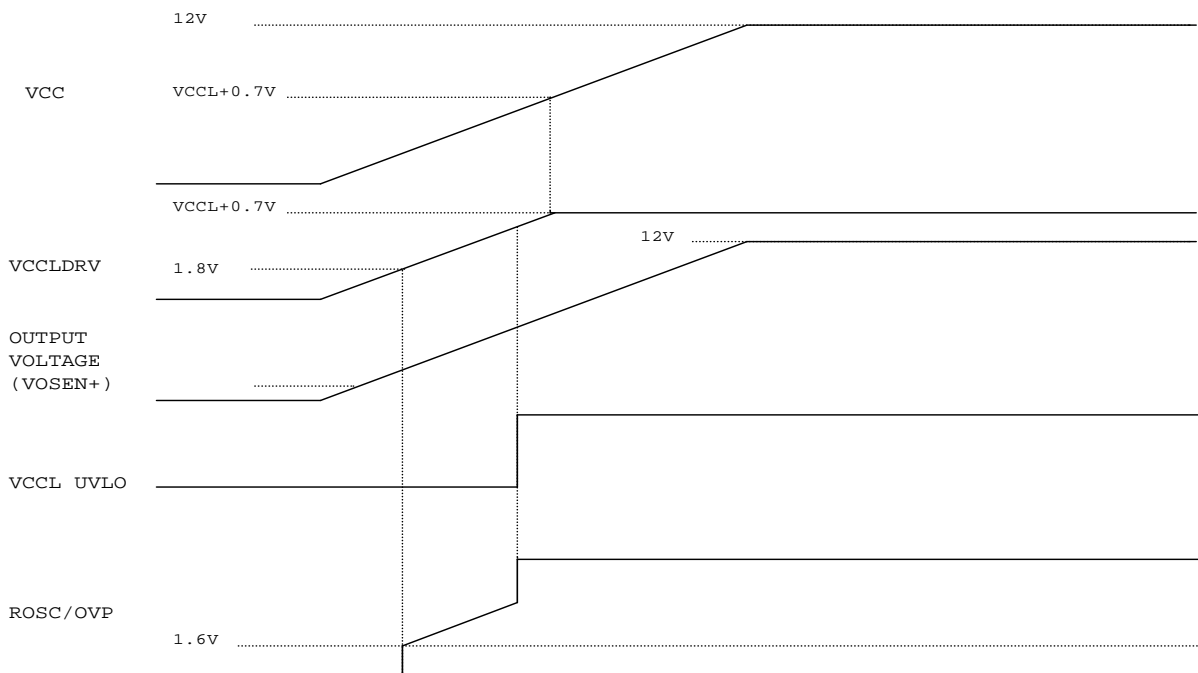

Figure 14 Over-voltage protection during power-up.

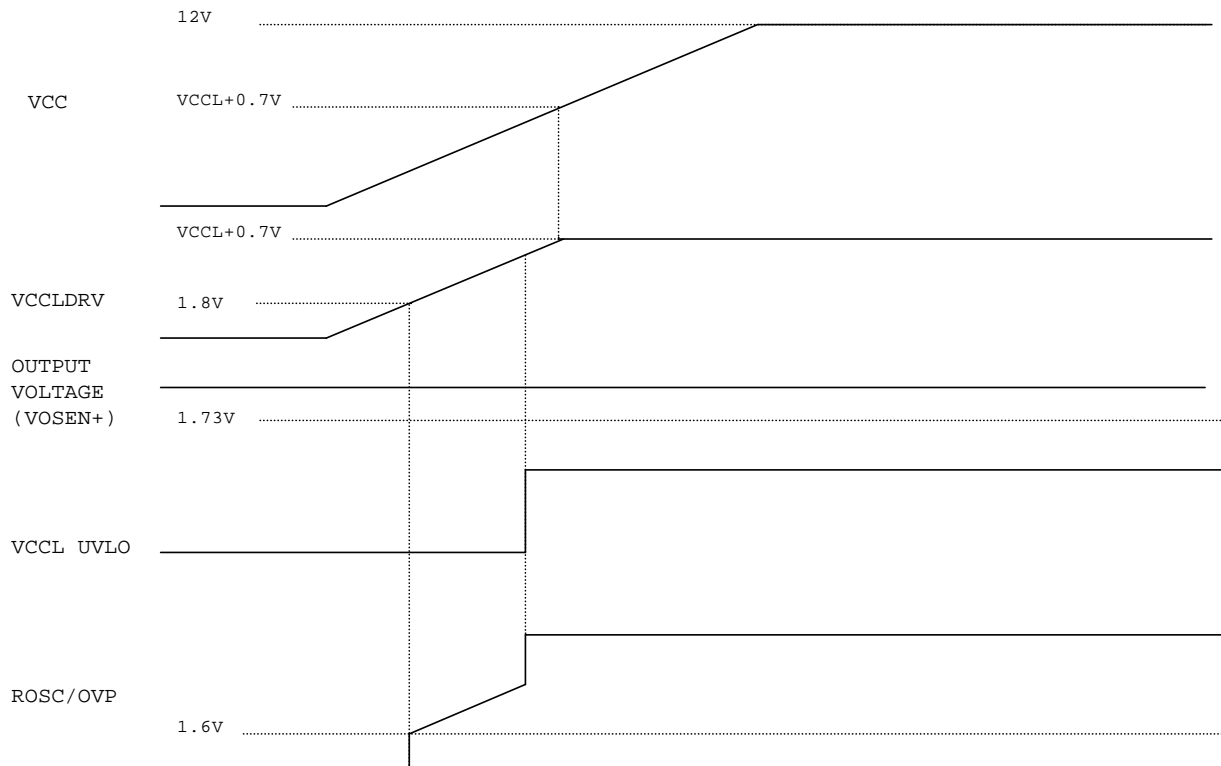

Figure 15 Over-voltage protection with pre-charging converter output $V_o > 1.73V$

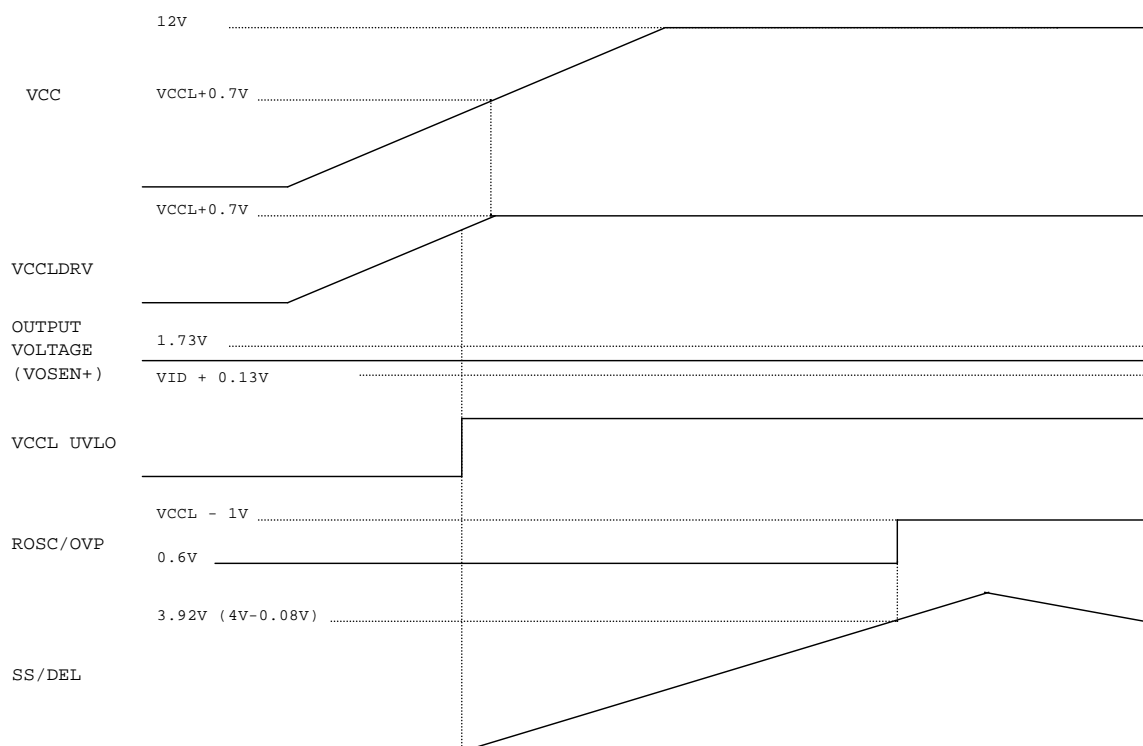

Figure 16 Over-voltage protection with pre-charging converter output $VID + 0.13V < V_o < 1.73V$

In the event of a high side MOSFET short before power up, the OVP flag is activated with as little supply voltage as possible, as shown in Figure 14. The VOSEN+ pin is compared against a fixed voltage of 1.73V (typical) for OVP conditions at power-up. The ROSC/OVP pin will be pulled higher than 1.6V with VCCLDRV voltage as low as 1.8V. An external MOSFET or comparator should be used to disable the silver box, activate a crowbar, or turn off the supply source. The 1.8V threshold is used to prevent false over-voltage triggering caused by pre-charging of output capacitors.

Pre-charging of converter may trigger OVP. If the converter output is pre-charged above 1.73V as shown in Figure 15, ROSC/OVP pin voltage will be higher than 1.6V when VCCLDRV voltage reaches 1.8V. ROSC/OVP pin voltage will be VCCLDRV-1V and rise with VCCLDRV voltage until VCCL is above UVLO threshold, after which ROSC/OVP pin voltage will be VCCL-1V. The converter cannot start unless the over voltage condition stops and VCCL is cycled. If the converter output is pre-charged 130mV above VDAC but lower than 1.73V, as shown in Figure 16, the converter will soft start until SS/DEL voltage is above 3.92V (4.0V-0.08V). Then, over voltage comparator is activated and fault latch is set.

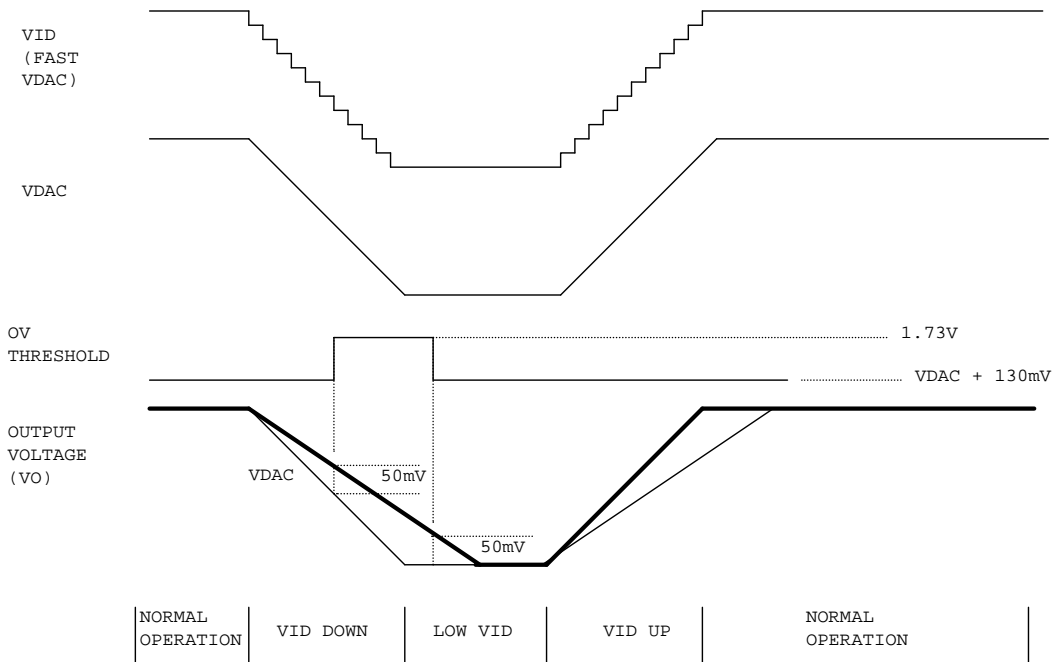

Figure 17 Over-voltage protection during dynamic VID

During dynamic VID down, OVP may be triggered when output voltage can not follow VDAC voltage change at light load with large output capacitance. Therefore, over-voltage threshold is raised to 1.73V from VDAC+130mV whenever dynamic VID is detected and the difference between output voltage and VDAC is more than 50mV, as shown in Figure 19. The over-voltage threshold is changed back to VDAC+130mV if the difference is smaller than 50mV.

VID Fault Codes

VID codes of 0000000X and 1111111X for VR11 will set the fault latch and disable the error amplifier. A 1.3us delay is provided to prevent a fault condition from occurring during Dynamic VID changes. A VID FAULT condition is latched with boot voltage and can only be cleared by cycling power to VCCL or re-issuing ENABLE.

Voltage Regulator Ready (PGOOD)

The PGOOD pin is an open-collector output and should be pulled up to a voltage source through a resistor. After the soft start completion cycle, the PGOOD remains high until the output voltage is in regulation and SS/DEL is above 3.92V. The PGOOD pin becomes low if the fault latch, over voltage latch, open sense line latch, or open daisy chain

is set. A high level at the PGOOD pin indicates that the converter is in operation and has no fault. The PGOOD stays high as long as the output voltage is within 300 mV of the programmed VID. During start-up, it is pulled low with an input voltage as low as 2 V. It stays low until the startup sequence has completed, and the output voltage has moved to the programmed VID.

Open Voltage Loop Detection

The output voltage range of error amplifier is detected all the time to ensure the voltage loop is in regulation. If any fault condition forces the error amplifier output above $VCCL-1.08V$ for 8 switching cycles, the fault latch is set. The fault latch can only be cleared by cycling power to VCCL.

Open Remote Sense Line Protection

If either remote sense line VOSEN+ or VOSEN- or both are open, the output of remote sense amplifier (VO) drops. The IR3502A monitors VO pin voltage continuously. If VO voltage is lower than 200 mV, two separate pulse currents are applied to VOSEN+ and VOSEN- pins respectively to check if the sense lines are open. If VOSEN+ is open, a voltage higher than 90% of $V(VCCL)$ will be present at VOSEN+ pin and the output of open line detect comparator will be high. If VOSEN- is open, a voltage higher than 700mV will be present at VOSEN- pin and the output of open-line-detect comparator will be high. The open sense line fault latch is set, which pulls error amplifier output low immediately and shut down the converter. The SS/DEL voltage is discharged and the fault latch can only be reset by cycling VCCL power. During dynamic VID down, OVP may be triggered when output voltage can not follow VDAC voltage change at light load with large output capacitance. Therefore, over-voltage threshold is raised to 1.73V from $VDAC+130mV$ whenever dynamic VID is detected and the difference between output voltage and VDAC is more than 50mV, as shown in Figure 17. The over-voltage threshold is changed back to $VDAC+130mV$ if the difference is smaller than 50mV.

Open Daisy Chain Protection

IR3502A checks the daisy chain every time it powers up. It starts a daisy chain pulse on the PHSOUT pin and detects the feedback at PHSIN pin. If no pulse comes back after 32 CLKOUT pulses, the pulse is restarted again. If the pulse fails to come back the second time, the open daisy chain fault is registered, and SS/DEL is not allowed to charge. The fault latch can only be reset by cycling the power to VCCL.

After powering up, the IR3502A monitors PHSIN pin for a phase input pulse equal or less than the number of phases detected. If PHSIN pulse does not return within the number of phases in the converter, another pulse is started on PHSOUT pin. If the second started PHSOUT pulse does not return on PHSIN, an open daisy chain fault is registered.

Enable Input

The ENABLE pin below 0.8V sets the Fault Latch and a voltage above 0.85V enables the soft start of the converter.

Thermal Monitoring (VRHOT)

A resistor divider including a thermistor at HOTSET pin sets the VRHOT threshold. The thermistor is usually placed at the temperature sensitive region of the converter, and is linearized by a series resistor. The IR3502A compare HOTSET pin voltage with a reference voltage of 1.6V. The VRHOT pin is an open-collector output and should be pulled up to a voltage source through a resistor. If the thermal trip point is reached the VRHOT output drives low. The hysteresis of the VRHOT comparator helps eliminate toggling of VRHOT output.

The overall system must be considered when designing for OVP. In many cases the over-current protection of the AC-DC or DC-DC converter supplying the multiphase converter will be triggered and provide effective protection without damage as long as all PCB traces and components are sized to handle the worst-case maximum current. If this is not possible, a fuse can be added in the input supply to the multiphase converter.

Phase Number Determination

After a daisy chain pulse is started, the IR3502A checks the timing of the input pulse at PHSIN pin to determine the phase number. This information is used to have symmetrical phase delay between phase switching without the need of any external component.

Single Phase Operation

In an architecture where only a single phase is needed the switching frequency is determined by the clock frequency.

CURRENT SHARE LOOP COMPENSATION

The internal compensation of current share loop ensures that crossover frequency of the current share loop is at least one decade lower than that of the voltage loop so that the interaction between the two loops is eliminated. The crossover frequency of current share loop is approximately 8 kHz.

Fault Operation Table

The Fault Table below describes the different faults that can occur and how IR3502A would react to protect the supply and the load from possible damage. The fault types that can occur are listed in row 1. Row 2 has the method that a fault is cleared. The first 5 faults are latched in the UV fault latch and the VCCL power has to be recycled by switching off the input and switching it back on for the converter to work again. The rest of the faults (except for UVLO Vout) are latched in the SS fault latch and does not need to recycle the VCCL power in order to resume normal operation once the fault condition clears. Most of the faults disable the error amplifier (EA) and discharge the soft start capacitor. All the faults flag PGOOD. PGOOD returns back to high when the faults are cleared. The delay row shows reaction time after detecting a fault condition. Delays are provided to minimize the possibility of nuisance faults.

	Fault Type									
	Open Daisy	Open Control Loop	Open Sense Line	Over Voltage	VID	Disable	VCCL UVLO	OC Before Start-up	OC After Start-up	VOUT UVLO
Fault Clearing Method	Recycle VCCL					Resume Normal Operation when Condition Clears				
Error Amp Disabled	Yes									No
ROSC/OVP & IIN drive high until OV clears	No			Yes	No					
SS/DEL Discharge	Yes									No
Flags PGood	Yes									
Delay?	32 Clock Pulses	8 PHSOUT Pulses	No	No	1.3us Blank Time	250 ns Blank Time	No	PHSOUT Pulses. Count Programmed by ROSC value	SS/DEL Discharge Threshold	No

DESIGN PROCEDURES - IR3502A AND IR3507 CHIPSET

IR3502A EXTERNAL COMPONENTS

Oscillator Resistor R_{osc}

The oscillator of IR3502A generates square-wave pulses to synchronize the phase ICs. The switching frequency of the each phase converter equals the PHSOUT frequency, which is set by the external resistor R_{osc} according to the curve in Figure 18. The CLKOUT frequency equals the switching frequency multiplied by the phase number. The R_{osc} sets the reference current used for no load offset which is given by Figure 19 and equals:

$$I_{SETPT} = \frac{0.595}{R_{osc}} \quad (1)$$

Soft Start Capacitor $C_{SS/DEL}$

The soft start capacitor $C_{SS/DEL}$ programs five different time parameters. They include soft start delay time, soft start time, VID sample delay time, VR ready delay time and over-current fault latch delay time after VR ready.

For the converter using VID with boot voltage, the SS/DEL pin voltage controls the slew rate of the converter output voltage, as shown in Figure 9. After the ENABLE pin voltage rises above 0.85V, there is a soft-start delay time TD1, after which the error amplifier output is released to allow the soft start of output voltage. The soft start time TD2 represents the time during which converter voltage rises from zero to 1.1V. The VID sample delay time (TD3) is the time period when VID stays at boot voltage of 1.1V. VID rise or fall time (TD4) is the time when VID changes from boot voltage to the final voltage. The VR ready delay time (TD5) is the time period from VR reaching the final voltage to the VR ready signal being issued, which is determined by the delay comparator threshold.

$C_{SS/DEL} = 0.1\mu\text{F}$ meets all the specifications of TD1 to TD5, which are determined by (2) to (6) respectively.

$$TD1 = \frac{C_{SS/DEL} * 1.4}{I_{CHG}} = \frac{C_{SS/DEL} * 1.4}{52.5 * 10^{-6}} \quad (2)$$

$$TD2 = \frac{C_{SS/DEL} * 1.1}{I_{CHG}} = \frac{C_{SS/DEL} * 1.1}{52.5 * 10^{-6}} \quad (3)$$

$$TD3 = \frac{C_{SS/DEL} * (3 - 1.4 - 1.1)}{I_{CHG}} = \frac{C_{SS/DEL} * 0.7}{52.5 * 10^{-6}} \quad (4)$$

$$TD4 = \frac{C_{SS/DEL} * |V_{DAC} - 1.1|}{I_{CHG}} = \frac{C_{SS/DEL} * |V_{DAC} - 1.1|}{52.5 * 10^{-6}} \quad (5)$$

$$TD5 = \frac{C_{SS/DEL} * (3.92 - 3)}{I_{CHG}} - TD4 = \frac{C_{SS/DEL} * 0.92}{52.5 * 10^{-6}} - TD4 \quad (6)$$

$$C_{SS/DEL} = \frac{TD2 * I_{CHG}}{V_O} = \frac{TD2 * 52.5 * 10^{-6}}{V_O} \quad (7)$$

The soft start delay time (TD1) and VR ready delay time (TD3) are determined by (8) to (9) respectively.

$$TD1 = \frac{C_{SS/DEL} * 1.4}{I_{CHG}} = \frac{C_{SS/DEL} * 1.4}{52.5 * 10^{-6}} \quad (8)$$

$$TD3 = \frac{C_{SS/DEL} * (4.0 - V_O)}{I_{CHG}} = \frac{C_{SS/DEL} * (4.0 - V_O)}{52.5 * 10^{-6}} \quad (9)$$

Once CSS/DEL is chosen, the minimum over-current fault latch delay time tOCDEL is fixed and can be quantified as

$$t_{OCDEL} = \frac{C_{SS/DEL} * 0.12}{I_{DISCHG}} = \frac{C_{SS/DEL} * 0.12}{55 * 10^{-6}} \quad (10)$$

VDAC Slew Rate Programming Capacitor CVDAC and Resistor RVDAC

The slew rate of VDAC slope SRDOWN can be programmed by the external capacitor CVDAC as defined in (11), where ISINK is the sink current of VDAC pin. The slew rate of VDAC up-slope is the same as that of down-slope. The resistor RVDAC is used to compensate VDAC circuit and can be calculated as follows

$$C_{VDAC} = \frac{I_{SINK}}{SR_{DOWN}} = \frac{44 * 10^{-6}}{SR_{DOWN}} \quad (11)$$

$$R_{VDAC} = \frac{1}{2 * \pi * 900kHz * C_{VDAC}} \quad (12)$$

Current Report Gain and Thermal Compensation

Intel VR11.1 specifications require IMON to report the core maximum load current of the CPU be reported as 1 V nominal. The core maximum current can be different for different platforms. The IMON tuning resistors can therefore be adjusted and thermally compensated to adjust the load current gain with respect to the IMON. The expressions that govern the relationship between load current, IMON, and VDRP at room temperature are given by

$$VDRP = VDAC + \frac{1}{3} * \left(\frac{R_{L_room} * G_{cs}}{n} \right) * \left[1 + \frac{(RTCMP2)II(RTCMP1 + RTHERM_room)}{RTCMP3} \right] * I_o \quad (13)$$

$$IMON = 50mV + \frac{1}{3} * \left(\frac{R_{L_room} * G_{cs}}{n} \right) * \left[1 + \frac{(RTCMP2)II(RTCMP1 + RTHERM_room)}{RTCMP3} \right] * I_o \quad (14)$$

The change in inductor DCR with temperature is compensated by an equivalent variation in the R THERM. The following equations derive the RTCMP1 and RTCMP2 if RTCMP3 and the thermistor (R THERM and β_{THERM}) are fixed.

$$R_{L_MAX} = R_{L_room} * [1 + 3850 * 10^{-6} * (T_{L_MAX} - T_{room})] \quad (15)$$

$$K_{THERM_room} = \frac{(1 - 50mV)}{I_{o\max}}, K_{c_room} = \frac{(R_{L_room} * G_{cs})}{n}, K_{c_t\max} = \frac{(R_{L_max} * G_{cs})}{n} \quad (16)$$

$$R_{t_room} = \left(\frac{3 \cdot K_{THERM_room}}{K_{c_room}} - 1 \right) \cdot RTCMP3 \quad (17)$$

$$R_{t_t\ max} = \left(\frac{3 \cdot K_{THERM_room}}{K_{c_t\ max}} - 1 \right) \cdot RTCMP3 \quad (18)$$

$$R_{THERM_{t\ max}} = R_{THERM_{room}} \cdot e^{\beta_{THERM} \left(\frac{1}{273+T_{max}} - \frac{1}{273+T_{room}} \right)} \quad (19)$$

$$B_{TH} = R_{THERM_{room}} + R_{THERM_{t\ max}} \quad (20)$$

$$C_{TH} = R_{THERM_{room}} \cdot R_{THERM_{t\ max}} - \left(\frac{R_{THERM_{room}} - R_{THERM_{t\ max}}}{\frac{1}{R_{t_t\ max}} - \frac{1}{R_{t_room}}} \right) \quad (21)$$

$$RTCMP1 = \frac{-B_{TH} + \sqrt{(B_{TH})^2 - 4 \cdot C_{TH}}}{2} \quad (22)$$

$$RTCMP2 = \frac{1}{\left(\frac{1}{R_{t_t\ max}} - \frac{1}{R_{t_t\ max} + RTCMP1} \right)} \quad (23)$$

Droop Resistor

The inductor DC resistance is utilized to sense the inductor current. The copper wire of inductor has a constant temperature coefficient of 3850 ppm/°C, and therefore the maximum inductor DCR can be calculated from (15), where $R_{L_t\ max}$ and R_{L_room} are the inductor DCR at maximum temperature T_{max} and room temperature T_{room} , respectively. After the thermal compensation is achieved using the procedure given above, the droop resistance can be calculated using the following equation.

$$R_{DRP} = \frac{1}{3} * \frac{R_{FB}}{R_o} * \left(\frac{G_{CS} * R_{L_ROOM}}{n} \right) * \left[1 + \frac{R_{t_room}}{RTCMP3} \right] \quad (24)$$

Over-current Threshold

Once the current report gain and the thermal compensation are calculated the OCP threshold is calculated using the following expression.

$$I_{ocp} = \frac{1.17}{\frac{1}{3} \cdot \left(\frac{R_{L_room} \cdot G_{cs}}{n} \right)} \cdot \left[1 + \frac{(RTCMP2)I(RTCMP1 + R_{THERM_room})}{RTCMP3} \right] \quad (25)$$

No Load Output Voltage Setting Resistor R_{VSETPT} ,

A resistor between VSETPT pin and VDAC is used to create output voltage offset V_{O_NLOFST} , which is the difference between VDAC voltage and output voltage at no load condition. R_{VSETPT} is determined by (26), where I_{VSETPT} is the current flowing out of VSETPT pin as shown in Figure 19.

$$R_{VSETPT} = \frac{V_{O_NLOFST}}{I_{VSETPT}} \quad (26)$$

Thermistor *R_{HOTSET3}* and Over Temperature Setting Resistors *R_{HOTSET1}* and *R_{HOTSET2}*

The threshold voltage of VRHOT comparator is fixed at 1.6V, and a negative temperature coefficient (NTC) thermistor *R_{HOTSET3}* is required to sense the temperature of the power stage. If we pre-select *R_{HOTSET3}*, the NTC thermistor resistance at allowed maximum temperature *T_{MAX}* is calculated from (27).

$$R_{TMAX} = R_{HOTSET3} * EXP[B_{HOTSET3} * (\frac{1}{T_{L_MAX}} - \frac{1}{T_{ROOM}})] \quad (27)$$

Select the series resistor *R_{HOTSET2}* to linearize the NTC thermistor, which has non-linear characteristics in the operational temperature range. Then calculate *R_{HOTSET1}* corresponding to the allowed maximum temperature *T_{MAX}* from (28).

$$R_{HOTSET1} = \frac{(R_{TMAX} + R_{HOTSET2}) * (VCCL - 1.6)}{1.6} \quad (28)$$

VCCL Capacitor *C_{VCCL}*

The capacitor is selected based on the stability requirement of the linear regulator and the load current to be driven. The linear regulator supplies the bias and gate drive current of the phase ICs. A 4.7uF normally ensures stable VCCL performance for Intel VR11.1 applications.

VCCL Regulator Drive Resistor *R_{VCCLDRV}*

The drive resistor is primarily dependent on the load current requirement of the linear regulator and the minimum input voltage requirements. The following equation gives an estimate of the average load current of the switching phase ICs.

$$I_{drive_avg} = [(Q_{gb} + Q_{gt}) \cdot f_{sw} + 10mA] \cdot n \quad (29)$$

Q_{gb} and *Q_{gt}* are the gate charge of the top and bottom FET. For a minimum input voltage and a maximum VCCL, the maximum *R_{VCCLDRV}* required to use the full pull-down current of the VCCL driver is given by

$$R_{VCCLDRV} = \frac{V_I(\min) - 0.7 - 6.8V}{I_{drive_avg} / \beta_{\min}} \quad (30)$$

Due to limited pull down capability of the VCCLDRV pin, make sure the following condition is satisfied.

$$\frac{V_I(\max) - 0.7 - 6.8V}{R_{VCCLDRV}} < 10mA \quad (31)$$

In the above equation, *V_I(min)* and *V_I(max)* is the minimum and maximum anticipated input voltage. If the above condition is not satisfied there is a need to use a device with higher β_{\min} or Darlington configuration can be used instead of a single NPN transistor.

Current Monitor Filter

A filter is added to isolate the CPU from rapid changes in the load current and trigger false response. A filter with 300 us time constant provides adequate delay for Intel VR11.1 response. A 1k resistor between IMON and local ground helps equalize the source and sink current of the IMON pin.

DESIGN EXAMPLE – HIGH FREQUENCY CONVERTER (FIG. 20)

SPECIFICATIONS

Input Voltage: $V_I=12\text{ V}$
 DAC Voltage: $V_{DAC}=1.2\text{ V}$
 No Load Output Voltage Offset: $V_{O_NLOFST}=10\text{ mV}$
 Continuous Output Current: $I_{OTDC}=110\text{ A}$
 Maximum DC Output Current: $I_{OMAX}=140\text{ A}$
 Current Report Gain =0.95 V represents I_{OMAX}
 Output Impedance: $R_O=0.8\text{ m}\Omega$
 Soft Start Delay Time: $TD1=0\text{-}5\text{ms}$
 Soft Start Time: $TD2=0.05\text{ms-}10\text{ms}$
 VID Sample Delay Time: $TD3=0.05\text{-}3\text{ms}$
 VID Rise Time: $TD4=0\text{-}3.5\text{ms}$
 VR Ready Delay Time: $TD5=0.05\text{ms-}3\text{ms}$
 Maximum Over Current Delay Time: $t_{OCDEL}<2.5\text{ms}$
 Dynamic VID Up-Slope Slew Rate: $SR_{up}=10\text{mV/us}$
 Over Temperature Threshold: $T_{MAX}=100\text{ }^\circ\text{C}$

POWER STAGE

Phase Number: $n=5$
 Switching Frequency: $f_{sw} = 700\text{ kHz}$
 Output Inductors: $L=70\text{ nH}$, $R_L=0.35\text{ m}\Omega$ (Including solder resistance)
 Output Capacitors: Ceramic: $C=22\mu\text{F}$, Number $N_c=50$
 SP: $C=220\mu\text{F}$, Number $N_{sp}=2$

IR3502A EXTERNAL COMPONENTS

Oscillator Resistor R_{osc}

Once the switching frequency is chosen, R_{osc} can be determined from the curve in Figure 18 of this data sheet. For a switching frequency of 700kHz per phase, choose $R_{osc} = 17.4\text{ k}\Omega$. The reference current is given by 30uA.

Soft Start Capacitor $C_{SS/DEL}$

Determine the soft start capacitor to meet the specifications of the delay time.

Choose $C_{SS/DEL}=0.1\mu\text{F}$. The soft start delay time is

$$TD1 = \frac{C_{SS/DEL} * 1.4}{I_{CHG}} = \frac{0.1 * 10^{-6} * 1.4}{52.5 * 10^{-6}} = 2.67\text{mS}$$

The soft start time is

$$TD2 = \frac{C_{SS/DEL} * 1.1}{I_{CHG}} = \frac{0.1 * 10^{-6} * 1.1}{52.5 * 10^{-6}} = 2.1\text{mS}$$

The VID sample delay time is

$$TD3 = \frac{C_{SS/DEL} * (3.2 - 1.4 - 1.1)}{I_{CHG}} = \frac{0.1 * 10^{-6} * 0.7}{52.5 * 10^{-6}} = 1.33\text{mS}$$

VID rise time is

$$TD4 = \frac{C_{SS/DEL} * |V_{DAC} - 1.1|}{I_{CHG}} = \frac{0.1 * 10^{-6} * |1.3 - 1.1|}{52.5 * 10^{-6}} = 0.38mS$$

The VR ready delay time is

$$TD5 = \frac{C_{SS/DEL} * (3.92 - 3)}{I_{CHG}} - TD4 = \frac{0.1 * 10^{-6} * 0.92}{52.5 * 10^{-6}} - TD4 = 1.37mS$$

Minimum over current fault latch delay time is

$$t_{OCDEL} = \frac{C_{SS/DEL} * 0.12}{I_{OCDISCHG}} = \frac{0.1 * 10^{-6} * 0.12}{55 * 10^{-6}} = 0.21mS$$

VDAC Slew Rate Programming Capacitor C_{VDAC} and Resistor R_{VDAC}

Calculate the VDAC down-slope slew-rate programming capacitor from the required down-slope slew rate. The up-slope slew rate is the same as the down-slope slew rate.

$$C_{VDAC} = \frac{I_{SINK}}{SR_{DOWN}} = \frac{44 * 10^{-6}}{10 * 10^{-3} / 10^{-6}} = 4.4nF$$

A 3.3 nF capacitor can be used. A series resistor is used to stabilize the VDAC buffer.

$$R_{VDAC} = \frac{1}{2 * \pi * 900kHz * C_{VDAC}} = 53\Omega \quad \text{A } 50 \Omega \text{ resistor is selected.}$$

No Load Output Voltage Setting Resistor R_{VSETPT}

From Figure 19, the bias current of VSETPT pin is 30 uA with $R_{OSC}=17.4 \text{ k}\Omega$.

$$R_{VSETPT} = \frac{V_{O_NLOFST}}{I_{VSETPT}} = \frac{10 * 10^{-3}}{30 * 10^{-6}} = 330\Omega$$

Current Report Gain and Thermal Compensation

The reporting gain specifies the max load current in form of a voltage. For this example, the 140 A represents 0.95 V at IMON. If the thermal effects are neglected (14) can be used to find the reporting gain. However, as the inductor DCR increases with temperature, the thermal compensation string (RTCMP1, RTCMP2, and R THERM) can be used to compensate this change in DCR.

Assuming $T_{room}=25 \text{ Deg}$, $T_{max}=100 \text{ Deg}$ the change in DCR is found our using (15)

$$R_{L_MAX} = 0.35m * [1 + 3850 * 10^{-6} * (100 - 25)] = 0.45m\Omega$$

Preselect $RTCMP3=1 \text{ k}\Omega$, and $R_{THERM_room}=10 \text{ k}\Omega$ with $\beta_{THERM}=3380K$ RTCMP1 and RTCMP2 can be found out using (16)-(23)

RTCMP1=8.837 k Ω

RTCMP2=8.457 k Ω

Droop Resistor

Based on the above calculation R_{DRP} can be selected to obtain specific output impedance.

Pre-select $R_{FB}=1\text{ k}\Omega$ and using $R_o=0.8\text{ m}\Omega$, $G_{cs}=33.5$ along with the converter parameters can be plugged into (24) to find out R_{DRP} .

$$R_{DRP} = \frac{1}{3} * \frac{1k\Omega}{0.8m\Omega} * \left(\frac{33.5 * 0.35m}{5} \right) * \left[1 + \frac{5.618k}{1k} \right] = 7.5k\Omega$$

Over Current Threshold

The OCP is fixed at 1.17 V above the VDAC voltage. Therefore, it can be determined as follows

$$I_{ocp} = \frac{1.17}{\left[\frac{1}{3} * \left(\frac{0.35m * 33.5}{5} \right) * \left(1 + \frac{(8.457k) * (8.837k + 10k)}{1k} \right) \right]} = 182A$$

VCCL Drive Resistor $R_{VCCLDRV}$

The maximum drive current for the linear regulator is dependent on the type of MosFET used. For this example, it's assumed that IR6622 and IRF6628 are used as the control and sync FET respectively.

$$I_{drive_avg} = [(30.3n + 11n) * 700k + 10mA] * 5 = 195mA$$

The minimum input voltage is assumed to be 10.5 V and VCCL is fixed at 6.5V for this design.

$$R_{VCCLDRV} = \frac{10.5V - 0.7V - 6.5V}{195mA / 30} = 700\Omega$$

Choose a transistor with $\beta(\text{min})$ of 50. The maximum input voltage is assumed 13.5 V,

$$\frac{13.5V - 0.7 - 6.5}{700\Omega} = 9mA < 10mA$$

Thermistor $R_{HOTSET3}$ and Over Temperature Setting Resistors $R_{HOTSET1}$ and $R_{HOTSET2}$

Choose NTC thermistor $R_{HOTSET3}=2.2k\Omega$, which has a constant of $B_{HOTSET3}=3520$, and the NTC thermistor resistance at the allowed maximum temperature T_{MAX} is,

$$R_{TMAX} = R_{HOTSET3} * EXP[B_{HOTSET3} * \left(\frac{1}{T_{L_MAX}} - \frac{1}{T_{ROOM}} \right)] = 2.2 * 10^3 * EXP[3520 * \left(\frac{1}{273 + 115} - \frac{1}{273 + 25} \right)] = 142\Omega$$

Select $R_{HOTSET2} = 931\Omega$ to linearize the NTC, which has non-linear characteristics in the operational temperature range. Then calculate $R_{HOTSET1}$ corresponding to the allowed maximum temperature T_{MAX} .

$$R_{HOTSET1} = \frac{(R_{TMAX} + R_{HOTSET2}) * (VCCL - 1.6)}{1.6} = \frac{(142 + 931) * (7 - 1.6)}{1.6} = 3.63k\Omega, \text{ choose } R_{HOTSET1}=3.65k\Omega.$$

IR3502 Frequency vs. ROSC Resistor

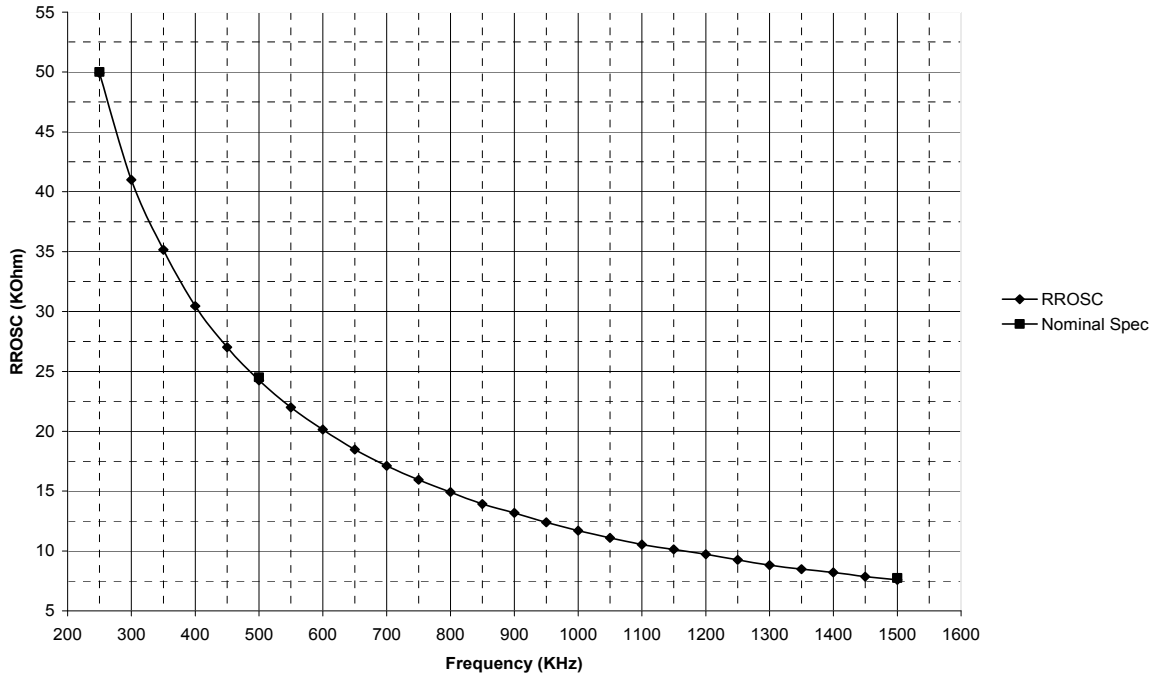

Figure 18: Frequency variation with ROSC.

I(VSETPT) vs. 1/RROSC

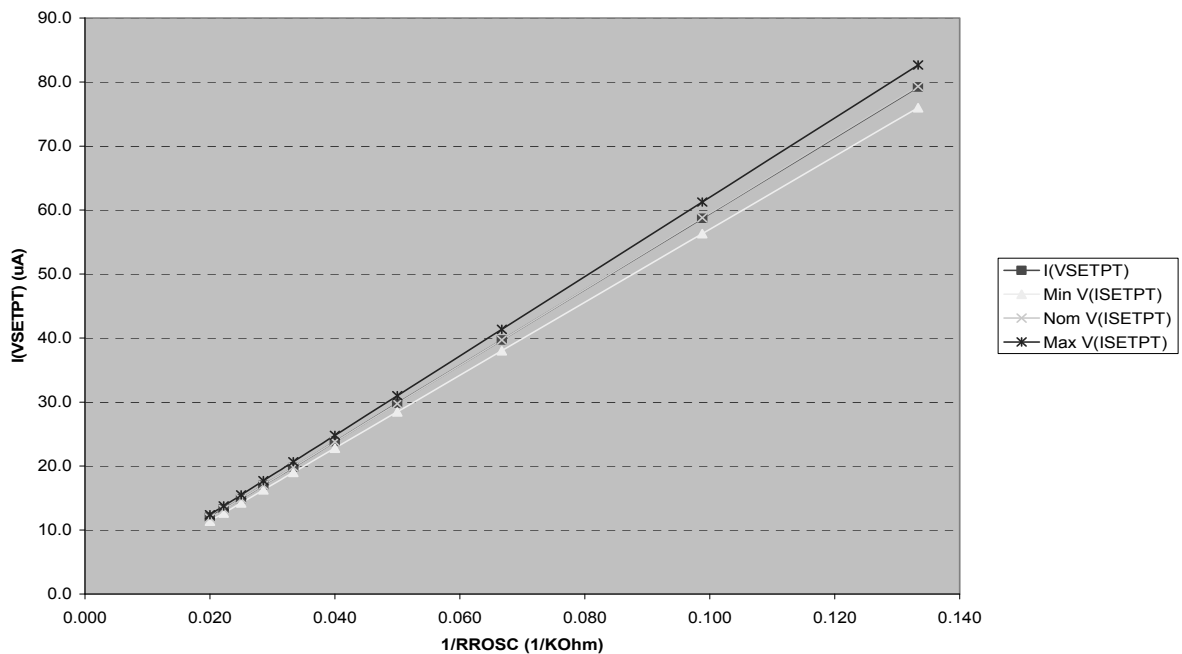
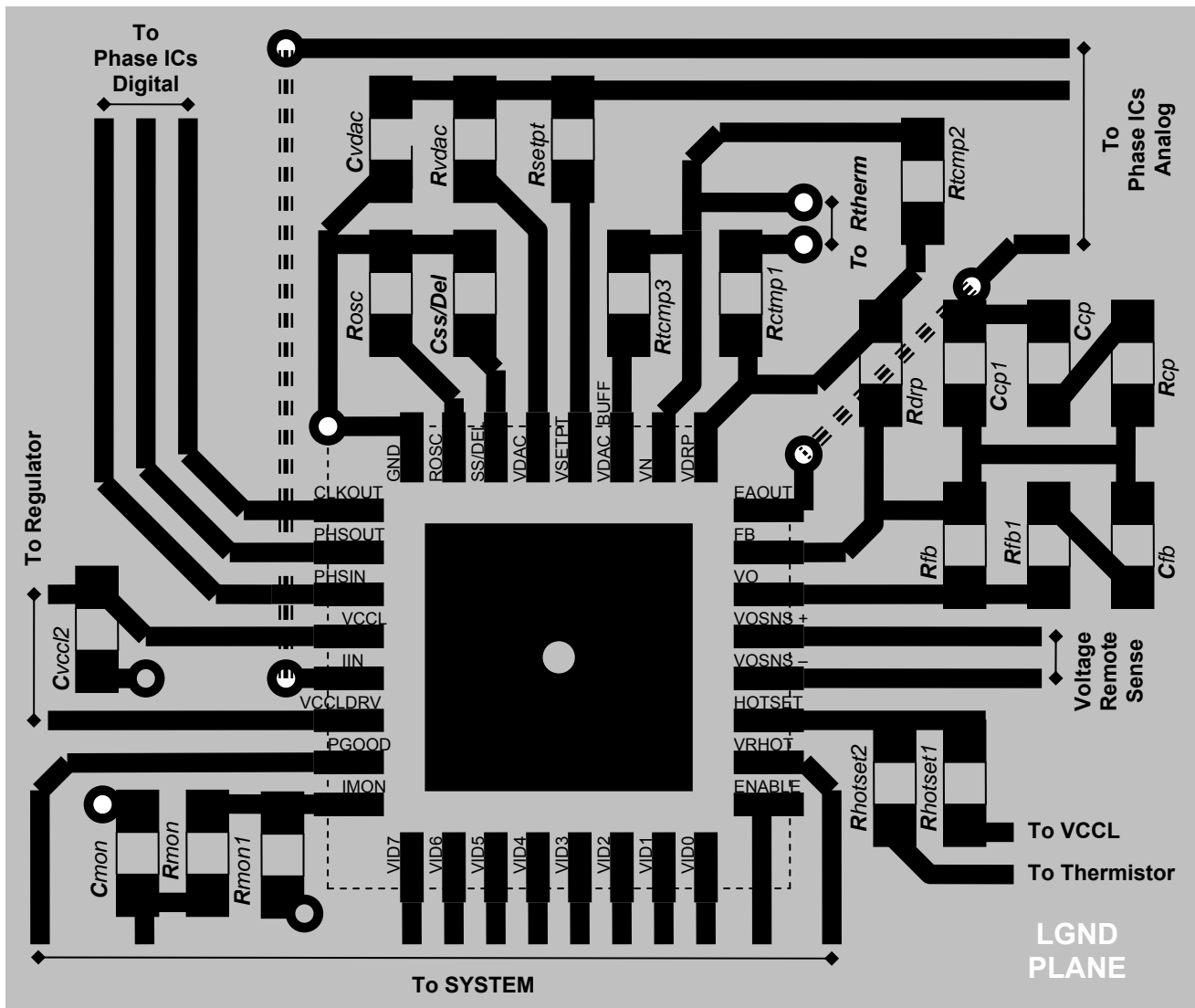

Figure 19: ISETPT with ROSC.

LAYOUT GUIDELINES

The following layout guidelines are recommended to reduce the parasitic inductance and resistance of the PCB layout, therefore minimizing the noise coupled to the IC.

- Dedicate at least one middle layer for a ground plane LGND.
- Connect the ground tab under the control IC to LGND plane through a via.
- Place VCCL decoupling capacitor VCCL as close as possible to VCCL and LGND pins.
- Place the following critical components on the same layer as control IC and position them as close as possible to the respective pins, ROSC, RVDAC, CVDAC, and CSS/DEL. Avoid using any via for the connection.
- Place the compensation components on the same layer as control IC and position them as close as possible to EAOUT, FB, VO and VDRP pins. Avoid using any via for the connection.
- Use Kelvin connections for the remote voltage sense signals, VOSNS+ and VOSNS-, and avoid crossing over the fast transition nodes, i.e. switching nodes, gate drive signals and bootstrap nodes.
- Avoid analog control bus signals, VDAC, IIN, and especially EAOUT, crossing over the fast transition nodes.
- Separate digital bus, CLKOUT, PHSOUT and PHSIN from the analog control bus and other compensation components.



STENCIL DESIGN

- The stencil apertures for the lead lands should be approximately 80% of the area of the lead lands. Reducing the amount of solder deposited will minimize the occurrence of lead shorts. Since for 0.5mm pitch devices the leads are only 0.25mm wide, the stencil apertures should not be made narrower; openings in stencils < 0.25mm wide are difficult to maintain repeatable solder release.
- The stencil lead land apertures should therefore be shortened in length by 80% and centered on the lead land.
- The land pad aperture should be striped with 0.25mm wide openings and spaces to deposit approximately 50% area of solder on the center pad. If too much solder is deposited on the center pad the part will float and the lead lands will be open.
- The maximum length and width of the land pad stencil aperture should be equal to the solder resist opening minus an annular 0.2mm pull back to decrease the incidence of shorting the center land to the lead lands when the part is pushed into the solder paste.

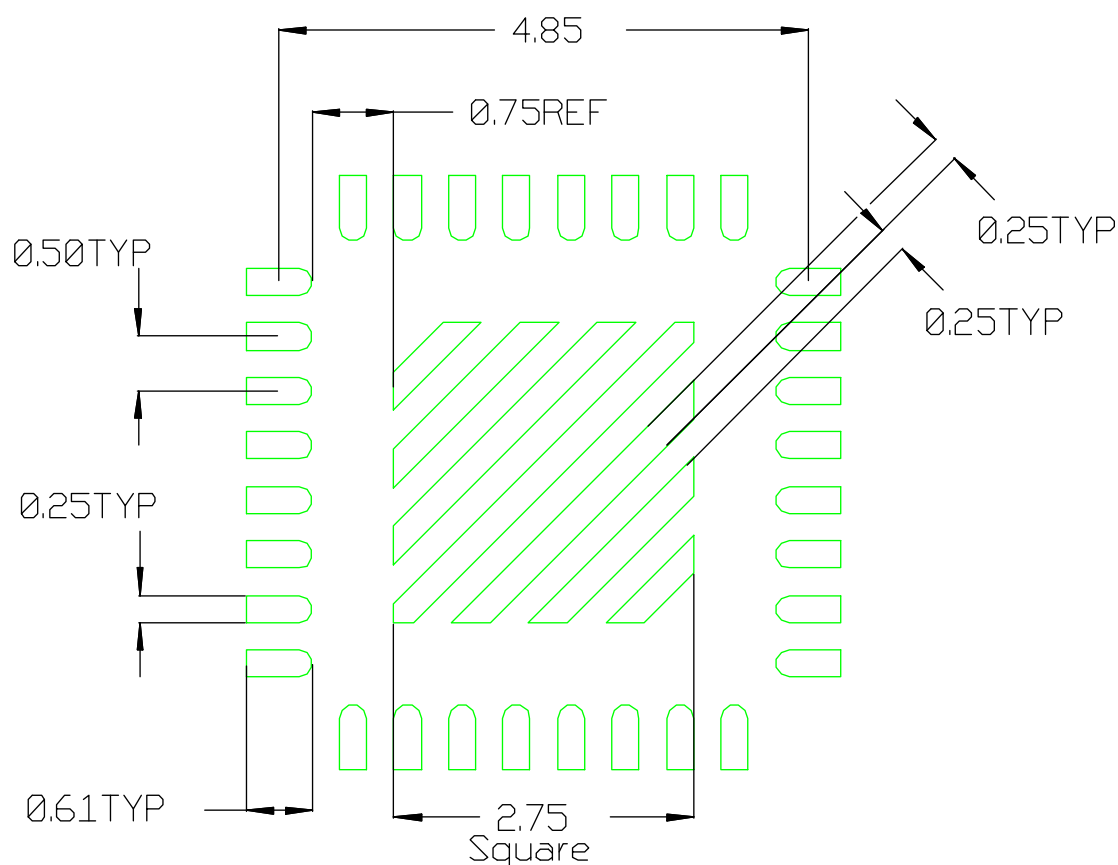

Stencil Aperture
 All Dimensions in mm

PACKAGE INFORMATION

32L MLPQ (5 x 5 mm Body) – $\theta_{JA} = 24.4^{\circ}\text{C/W}$, $\theta_{JC} = 0.86^{\circ}\text{C/W}$

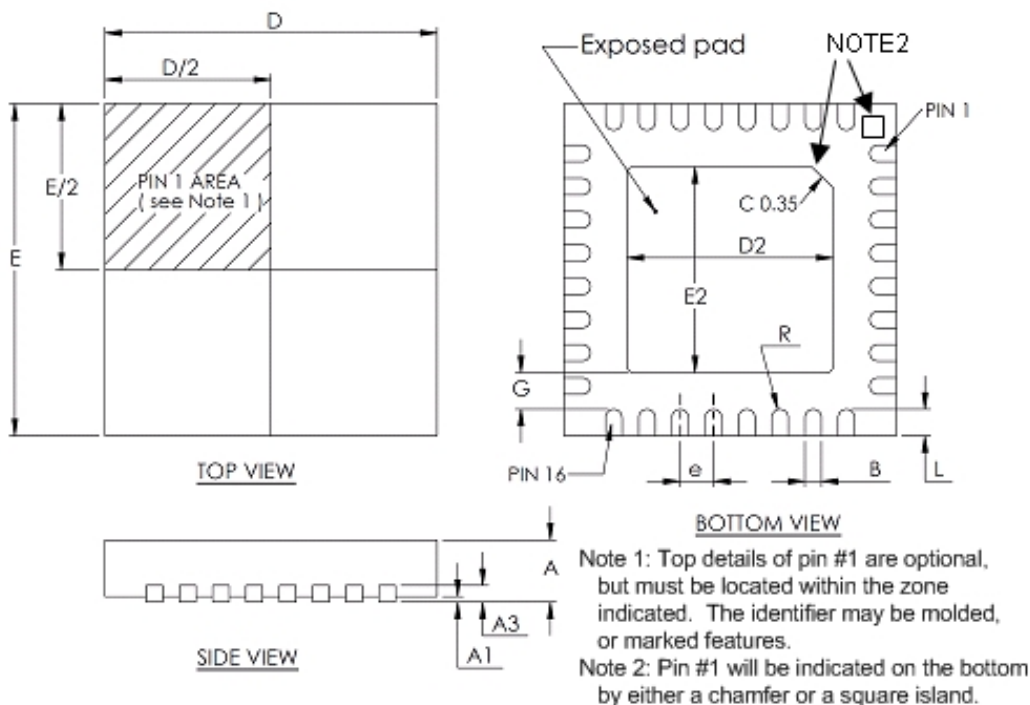

32-PIN 5x5 (unit: MM)			
DIM	MIN	NOM	MAX
A	0.8	0.85	0.9
A1	0.00		0.05
A3	0.20 REF		
B	0.20	0.25	0.30
D	4.95	5.00	5.05
D2	3.00	3.10	3.20
E	4.95	5.00	5.05
E2	3.00	3.10	3.20
e	0.5 REF		
G	0.55 REF		
L	0.30	0.40	0.50
R	0.125 TYP		

Data and specifications subject to change without notice.
 This product has been designed and qualified for the Consumer market.
 Qualification Standards can be found on IR's Web site.

Looking for pricing, stock, or lifecycle information?

Click below to explore more details on WIN SOURCE:

 [View IR3502AMTRPBF on WIN SOURCE](#)

 [Infineon Technologies](#) Information

Optimize Your Supply Chain with WIN SOURCE Solutions

-  Global Sourcing Solution
-  Obsolete Management
-  Cost Control Management
-  Shortage Management
-  Alternative Solution
-  Excess Inventory Management