



**THE DATASHEET OF
NB7L14MN1TWG**



2.5 V / 3.3 V 7 GHz / 10 Gbps Differential 1:4 LVPECL Fanout Buffer

Multi-Level Inputs with Internal Termination

NB7L14

Description

The NB7L14 is a differential 1:4 LVPECL fanout buffer. The NB7L14 produces four identical LVPECL output copies of Clock or Data operating up to 7 GHz or 10.7 Gb/s, respectively. As such, the NB7L14 is ideal for SONET, GigE, Fiber Channel, Backplane and other Clock or Data distribution applications.

The differential inputs incorporate internal 50 Ω termination resistors that are accessed through the VT Pin. This feature allows the NB7L14 to accept various logic standards, such as LVPECL, CML, LVDS, LVCMOS or LVTTTL logic levels. The V_{REFAC} reference output can be used to rebias capacitor-coupled differential or single-ended input signals. The 1:4 fanout design was optimized for low output skew applications.

The NB7L14 is a member of the GigaComm™ family of high performance clock products.

Features

- Input Data Rate > 10.7 Gb/s
- Input Clock Frequency > 7 GHz
- 165 ps Typical Propagation Delay
- 45 ps Typical Rise and Fall Times
- <15 ps max Output Skew
- <0.8 ps maximum RMS Clock Jitter
- <15 ps pp of Data Dependent Jitter
- Differential LVPECL Outputs, 720 mV peak-to-peak, typical
- LVPECL Operating Range: V_{CC} = 2.375 V to 3.6 V with GND = 0 V
- NECL Operating Range: V_{CC} = 0 V with GND = -2.375 V to -3.6 V
- Internal Input Termination Resistors, 50 Ω
- V_{REFAC} Reference Output
- Functionally Compatible with Existing 2.5 V/3.3 V LVEL, LVEP, EP, and SG Devices
- -40°C to +85°C Ambient Operating Temperature
- These Devices are Pb-Free are RoHS compliant



QFN-16
MN SUFFIX
CASE 485G



QFN-16
MN SUFFIX
CASE 485AE

MARKING DIAGRAMS*



XXXX = Specific Device Code
A = Assembly Location
L = Wafer Lot
Y = Year
W = Work Week
▪ = Pb-Free Package

(Note: Microdot may be in either location)

*For additional marking information, refer to Application Note [AND8002/D](#).

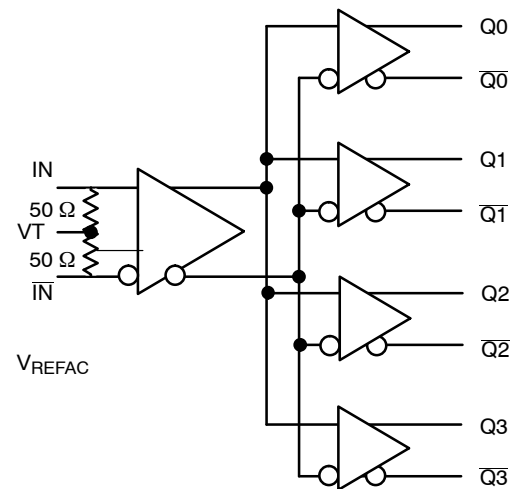

Figure 1. Logic Diagram

ORDERING INFORMATION

See detailed ordering and shipping information in the package dimensions section on page 10 of this data sheet.

NB7L14

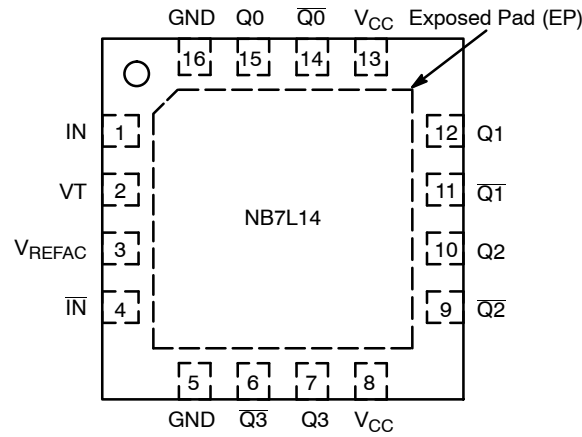

Figure 2. QFN-16 Pinout (Top View)

Table 1. PIN DESCRIPTION

Pin	Name	I/O	Description
1	IN	ECL, CML, LVCMOS, LVDS, LVTTL Input	Non-inverted Differential Input. Note 1. Internal 50 Ω Resistor to Termination Pin, VT
2	VT	-	Internal 50- Ω Termination Pin for IN/ $\bar{I}N$ inputs.
3	VREFAC		Output Reference Voltage for capacitor-coupled inputs
4	$\bar{I}N$	ECL, CML, LVCMOS, LVDS, LVTTL Input	Inverted Differential Input. Note 1. Internal 50 Ω Resistor to Termination Pin, VT.
5	GND	-	Negative Supply Voltage
6	$\bar{Q}3$	LVPECL Output	Inverted Differential Output. Typically Terminated with 50 Ω Resistor to $V_{CC} - 2.0$ V.
7	Q3	LVPECL Output	Non-inverted Differential Output. Typically Terminated with 50 Ω Resistor to $V_{CC} - 2.0$ V.
8	VCC	-	Positive Supply Voltage
9	$\bar{Q}2$	LVPECL Output	Inverted Differential Output. Typically Terminated with 50 Ω Resistor to $V_{CC} - 2.0$ V.
10	Q2	LVPECL Output	Non-inverted Differential Output. Typically Terminated with 50 Ω Resistor to $V_{CC} - 2.0$ V.
11	$\bar{Q}1$	LVPECL Output	Inverted Differential Output. Typically Terminated with 50 Ω Resistor to $V_{CC} - 2.0$ V.
12	Q1	LVPECL Output	Non-inverted Differential Output. Typically Terminated with 50 Ω Resistor to $V_{CC} - 2.0$ V.
13	VCC	-	Positive Supply Voltage
14	$\bar{Q}0$	LVPECL Output	Inverted Differential Output. Typically Terminated with 50 Ω Resistor to $V_{CC} - 2.0$ V.
15	Q0	LVPECL Output	Non-inverted Differential Output. Typically Terminated with 50 Ω Resistor to $V_{CC} - 2.0$ V.
16	GND	-	Negative Supply Voltage
-	EP	-	The Exposed Pad (EP) on the QFN-16 package bottom is thermally connected to the die for improved heat transfer out of package. The exposed pad must be attached to a heat-sinking conduit. The pad is electrically connected to the die, and must be electrically connected to device GND.

1. In the differential configuration when the input termination pin (VT) is connected to a common termination voltage or left open, and if no signal is applied on IN/ $\bar{I}N$ input, then, the device will be susceptible to self-oscillation.
2. All VCC and GND pins must be externally connected to a power supply for proper operation.

NB7L14

Table 2. ATTRIBUTES

Characteristics	Value
ESD Protection Human Body Model Machine Model	> 2000 V > 150 V
Moisture Sensitivity (Note 3) QFN-16	Level 1
Flammability Rating Oxygen Index: 28 to 34	UL 94 V-0 @ 0.125 in
Transistor Count	173
Meets or exceeds JEDEC Spec EIA/JESD78 IC Latchup Test	

3. For additional information, see Application Note [AND8003/D](#).

Table 3. MAXIMUM RATINGS

Symbol	Parameter	Condition 1	Condition 2	Rating	Unit
V_{CC}	Positive Power Supply	GND = 0 V		-0.5 V to +4.0	V
V_{IO}	Positive Input/Output Voltage	GND = 0 V	$-0.5 \leq V_{IO} \leq V_{CC} + 0.5$	4.0	V
V_{INPP}	Differential Input Voltage $ D - \bar{D} $			2.8	V
I_{IN}	Input Current Through R_T (50 Ω Resistor)			± 40	mA
I_{OUT}	Output Current (LVPECL Output)	Continuous Surge		50 100	mA
$I_{VFREFAC}$	V_{REFAC} Sink/Source Current			± 1.5	mA
T_A	Operating Temperature Range	QFN-16		-40 to +85	$^{\circ}C$
T_{stg}	Storage Temperature Range			-65 to +150	$^{\circ}C$
θ_{JA}	Thermal Resistance (Junction-to-Ambient) (Note 4)	0 lfpm 500 lfpm	QFN-16 QFN-16	42 35	$^{\circ}C/W$
θ_{JC}	Thermal Resistance (Junction-to-Case) (Note 4)		QFN-16	4	$^{\circ}C/W$
T_{sol}	Wave Solder Pb-Free			265	$^{\circ}C$

Stresses exceeding those listed in the Maximum Ratings table may damage the device. If any of these limits are exceeded, device functionality should not be assumed, damage may occur and reliability may be affected.

4. JEDEC standard multilayer board – 2S2P (2 signal, 2 power) with 8 filled thermal vias under exposed pad.

NB7L14

Table 4. DC CHARACTERISTICS, MULTI-LEVEL INPUTS $V_{CC} = 2.375\text{ V to }3.6\text{ V}$, $GND = 0\text{ V}$, $T_A = -40^\circ\text{C to }+85^\circ\text{C}$

Symbol	Characteristic	Min	Typ	Max	Unit
--------	----------------	-----	-----	-----	------

POWER SUPPLY CURRENT

V_{CC}	Power Supply Voltage	$V_{CC} = 2.5\text{ V}$ $V_{CC} = 3.3\text{ V}$	2.375 3.0	2.5 3.3	2.625 3.6	V
I_{CC}	Power Supply Current (Inputs and Outputs Open)			85	105	mA

LVPECL OUTPUTS (Notes 5 & 6)

V_{OH}	Output HIGH Voltage	$V_{CC} = 2.5\text{ V}$ $V_{CC} = 3.3\text{ V}$	$V_{CC} - 1145$ 1355 2155	$V_{CC} - 900$ 1600 2400	$V_{CC} - 825$ 1675 2475	mV
V_{OL}	Output LOW Voltage	$V_{CC} = 2.5\text{ V}$ $V_{CC} = 3.3\text{ V}$	$V_{CC} - 2000$ 500 1300	$V_{CC} - 1700$ 800 1600	$V_{CC} - 1500$ 1000 1800	mV

DIFFERENTIAL INPUT DRIVEN SINGLE-ENDED (see Figure 5 & 7) (Note 7)

V_{IH}	Single-ended Input HIGH Voltage		$V_{th} + 75$		V_{CC}	mV
V_{IL}	Single-ended Input LOW Voltage		GND		$V_{th} - 75$	mV
V_{th}	Input Threshold Reference Voltage Range (Note 8)		1125		$V_{CC} - 75$	mV
V_{ISE}	Single-ended Input Voltage Amplitude ($V_{IH} - V_{IL}$)		150		2800	mV

VREFAC

V_{REFAC}	Output Reference Voltage (100 μA Load)		$V_{CC} - 1400$	$V_{CC} - 1300$	$V_{CC} - 1000$	mV
-------------	---------------------------------------------------	--	-----------------	-----------------	-----------------	----

DIFFERENTIAL INPUTS DRIVEN DIFFERENTIALLY (see Figure 6 & 8) (Note 9)

V_{IHD}	Differential Input HIGH Voltage		1200		V_{CC}	mV
V_{ILD}	Differential Input LOW Voltage		0		$V_{IHD} - 50$	mV
V_{ID}	Differential Input Voltage ($V_{IHD} - V_{ILD}$)		100		2800	mV
V_{CMR}	Input Common Mode Range (Differential Configuration) (Note 10) (Figure 9)		950		$V_{CC} - 50$	mV
I_{IH}	Input HIGH Current $I_N / \overline{I_N}$, (VT Open)		-150		150	μA
I_{IL}	Input LOW Current $I_N / \overline{I_N}$, (VT Open)		-150		150	μA

TERMINATION RESISTORS

R_{TIN}	Internal Input Termination Resistor		45	50	55	Ω
-----------	-------------------------------------	--	----	----	----	----------

NOTE: Device will meet the specifications after thermal equilibrium has been established when mounted in a test socket or printed circuit board with maintained transverse airflow greater than 500 lfm.

5. LVPECL outputs loaded with 50 Ω to $V_{CC} - 2.0\text{ V}$ for proper operation.
6. Input and output parameters vary 1:1 with V_{CC} .
7. V_{th} , V_{IH} , V_{IL} , and V_{ISE} parameters must be complied with simultaneously.
8. V_{th} is applied to the complementary input when operating in single-ended mode.
9. V_{IHD} , V_{ILD} , V_{ID} and V_{CMR} parameters must be complied with simultaneously.
10. V_{MR} min varies 1:1 with V_{EE} , V_{CMR} max varies 1:1 with V_{CC} . The V_{CMR} range is referenced to the most positive side of the differential input signal.

NB7L14

Table 5. AC CHARACTERISTICS $V_{CC} = 2.375\text{ V to }3.6\text{ V}$, $GND = 0\text{ V}$, $T_A = -40^\circ\text{C to }+85^\circ\text{C}$; (Note 11)

Symbol	Characteristic	Min	Typ	Max	Unit
f_{MAX}	Maximum Input Clock Frequency; $V_{OUT} \geq 400\text{ mV}$	7	8		GHz
$f_{DATAMAX}$	Maximum Operating Data Rate; NRZ, (PRBS23)	10	11		Gbps
V_{OUTPP}	Output Voltage Amplitude (Note 15) (See Figure 9)	$f_{in} \leq 5\text{ GHz}$ 400	720 450		mV
t_{PLH} , t_{PHL}	Propagation Delay IN to Q	125	165	200	ps
t_{SKEW}	Duty Cycle Skew (Note 12) Output – Output Within Device Skew Device to Device Skew		3	15 15 50	ps
t_{DC}	Output Clock Duty Cycle (Reference Duty Cycle = 50%)		50	55	%
t_{JITTER}	RMS Random Clock Jitter (Note 13) Peak-to-Peak Data Dependent Jitter (Note 14)		$f_{in} \leq 7\text{ GHz}$ 5	0.8 15	ps rms ps pk-pk
$t_{jit}(\phi)$	Additive RMS Phase Jitter $f_c = 622.08\text{ MHz}$, Integration Range: 12 kHz to 20 MHz (See Figure 17)		24		fs
V_{INPP}	Input Voltage Swing/Sensitivity (Differential Configuration) (Note 15)	100		1200	mV
t_r t_f	Output Rise/Fall Times @ 1.0 GHz (20% – 80%)		45	60	ps

NOTE: Device will meet the specifications after thermal equilibrium has been established when mounted in a test socket or printed circuit board with maintained transverse airflow greater than 500 lfp/m.

11. Measured by forcing $V_{INPP}(\text{min})$ from a 50% duty cycle clock source. All loading with an external $R_L = 50\ \Omega$ to $V_{CC} - 2.0\text{ V}$. Input edge rates 40 ps (20% – 80%).
12. Skew is measured between outputs under identical transitions and conditions @ 0.5 GHz. Duty cycle skew is measured between differential outputs using the deviations of the sum of T_{pw-} and T_{pw+} @ 0.5 GHz.
13. Additive RMS jitter with 50% duty cycle clock signal.
14. Additive peak-to-peak data dependent jitter with input NRZ data at PRBS23.
15. Input and output voltage swing is a single-ended measurement operating in differential mode.

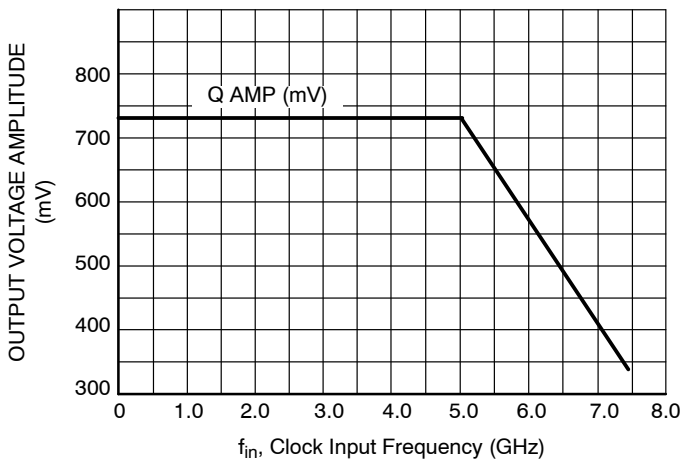

Figure 3. CLOCK Output Voltage Amplitude (V_{OUTPP}) vs. Input Frequency (f_{in}) at Ambient Temperature (Typ)

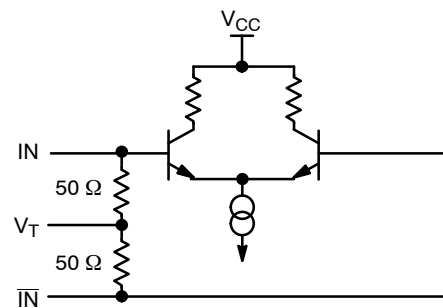

Figure 4. Input Structure

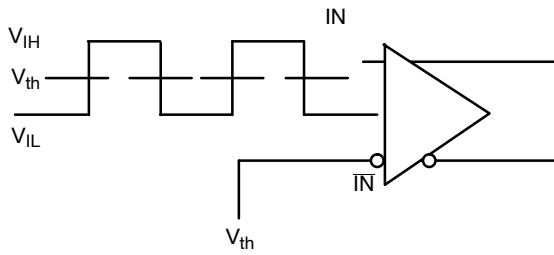

Figure 5. Differential Input Driven Single-Ended

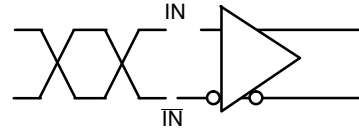

Figure 6. Differential Inputs Driven Differentially

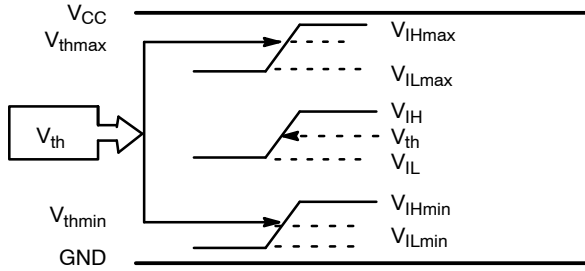

Figure 7. V_{th} Diagram

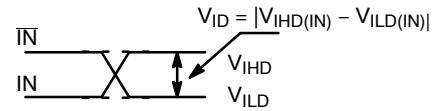

Figure 8. Differential Inputs Driven Differentially

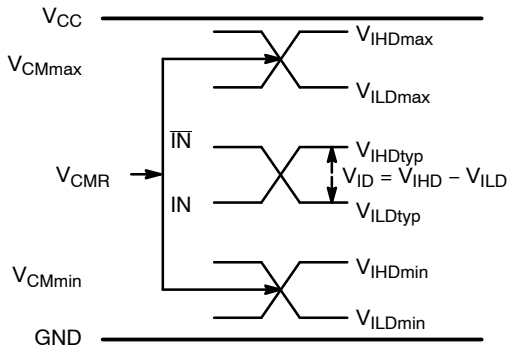

Figure 9. V_{CMR} Diagram

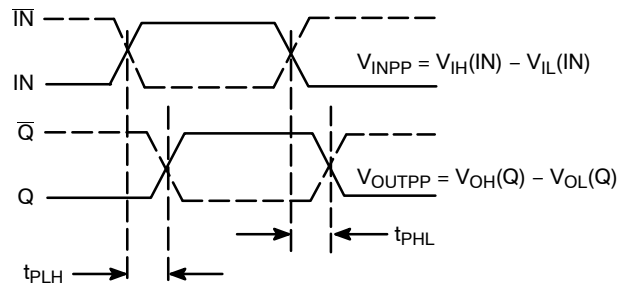

Figure 10. AC Reference Measurement

NB7L14

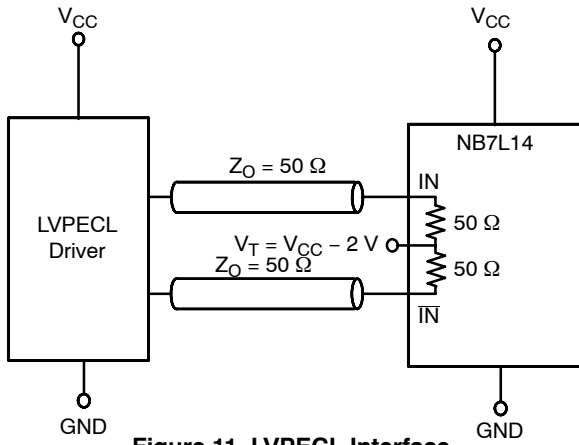

Figure 11. LVPECL Interface

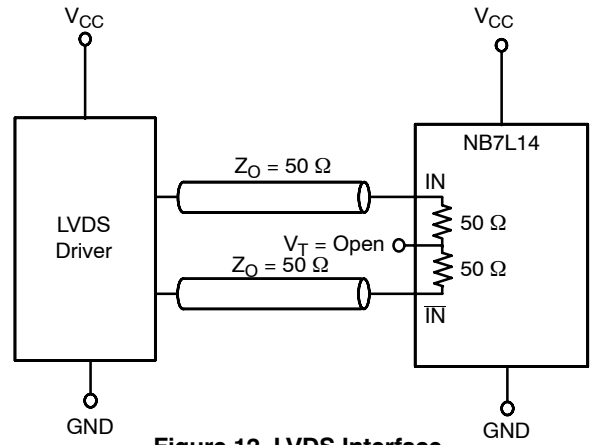

Figure 12. LVDS Interface

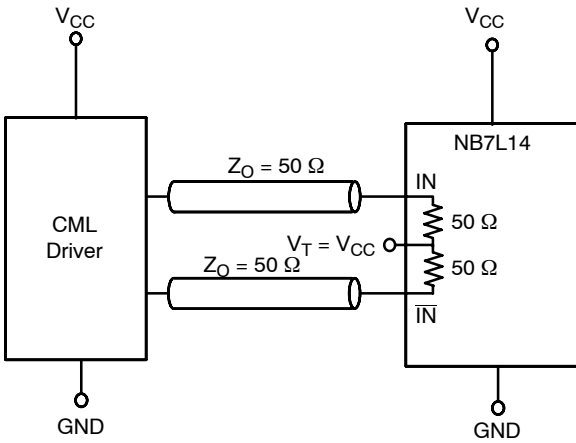

Figure 13. Standard 50 Ω Load CML Interface

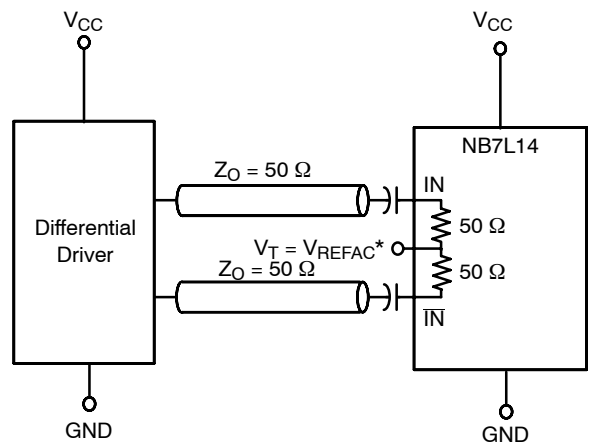

Figure 14. Capacitor-Coupled Differential Interface

(V_T Connected to External V_{REFAC})

* V_{REFAC} bypassed to ground with a 0.01 μF capacitor

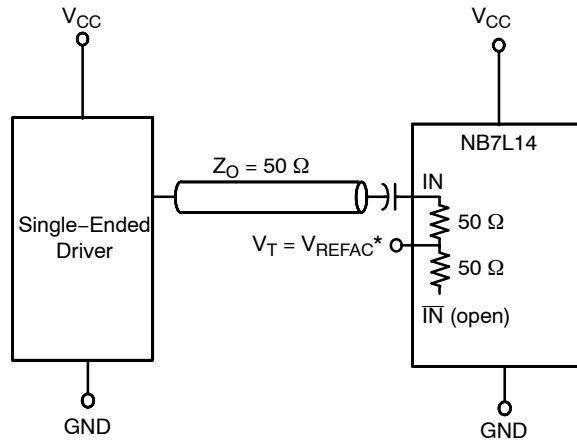

Figure 15. Capacitor-Coupled Differential Interface (V_T Connected to External V_{REFAC})

* V_{REFAC} bypassed to ground with a 0.01 μF capacitor

NB7L14

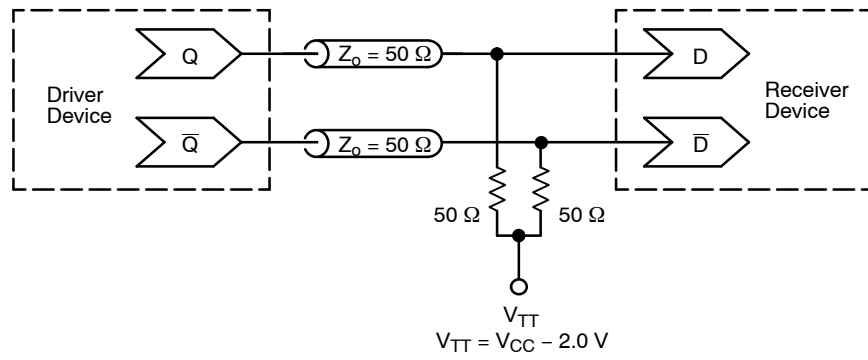

Figure 16. Typical Termination for Output Driver and Device Evaluation
(See Application Note [AND8020/D](#) – Termination of ECL Logic Devices.)

NB7L14

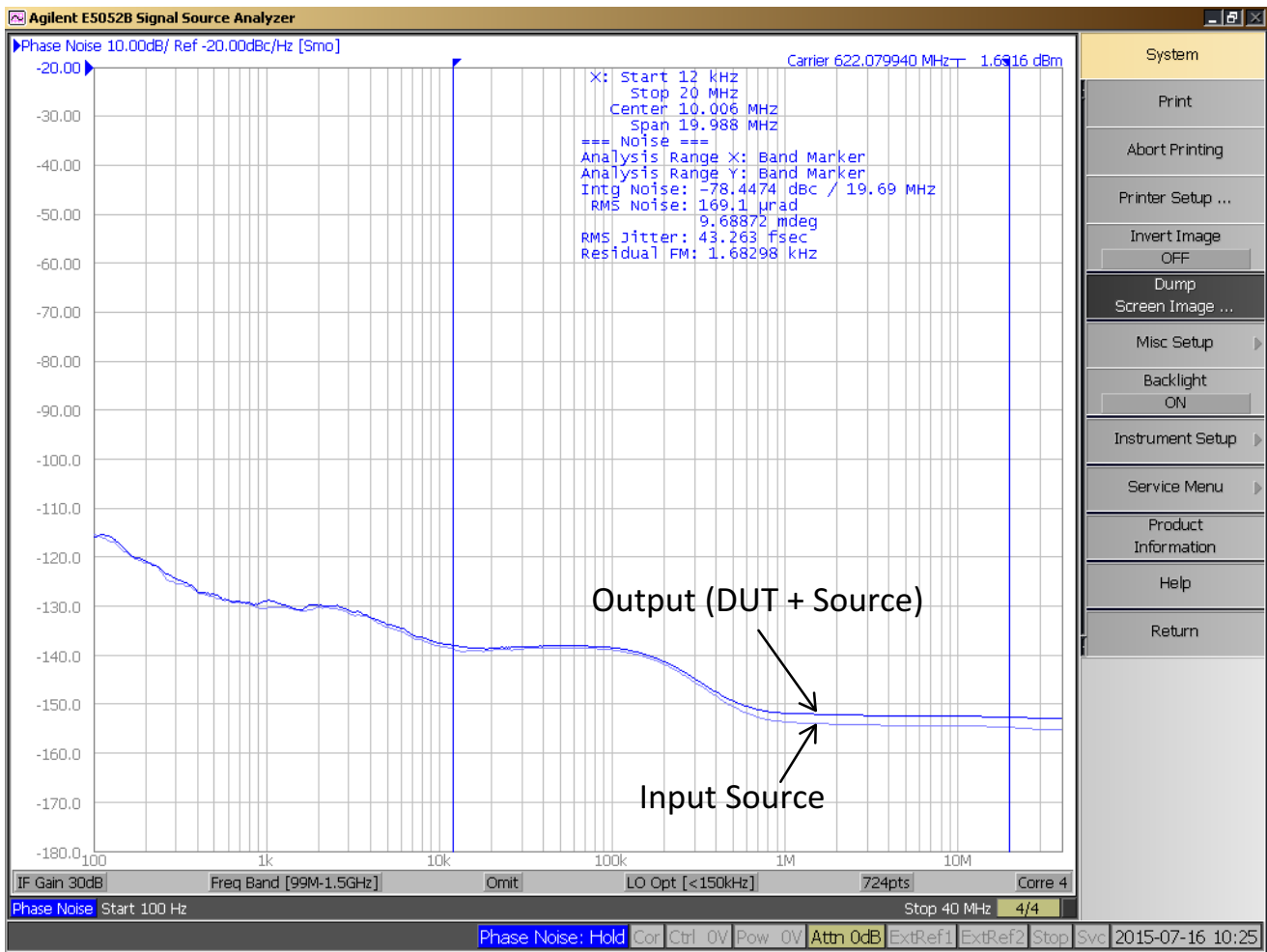

Figure 17. Typical NB7L14 Phase Noise Plot at $f_{\text{carrier}} = 622.08 \text{ MHz}$, $V_{\text{CC}} = 3.3 \text{ V}$, 25°C

The above phase noise data was captured using Agilent E5052A/B. The data displays the input phase noise and output phase noise used to calculate the additive phase jitter at a specified integration range. The additive RMS phase jitter contributed by the device (integrated between 12 kHz and 20 MHz) is 24 fs. The additive RMS phase jitter performance of the translator is highly dependent on the phase noise of the input source.

To obtain the most precise additive phase noise measurement, it is vital that the source phase noise be

notably lower than that of the DUT. If the phase noise of the source is greater than the noise floor of the device under test, the source noise will dominate the additive phase jitter calculation and lead to an incorrect negative result for the additive phase noise within the integration range. The Figure above is a good example of the NB7L14 source generator phase noise having a significantly lower floor than the DUT and results in an additive phase jitter of 24 fs.

$$\text{Additive RMS phase jitter} = \sqrt{\text{RMS phase jitter of output}^2 - \text{RMS phase jitter of input}^2}$$

$$24 \text{ fs} = \sqrt{43.26 \text{ fs}^2 - 35.98 \text{ fs}^2}$$

To see the performance of NB7L14 beyond conditions outlined in this datasheet use our Phase Noise Explorer web tool located at ON Semiconductor [Green Point Design Tools](#)

homepage. This free application enables an interactive environment for advanced phase noise and jitter analysis of timing devices and clock tree designs.

NB7L14

ORDERING INFORMATION

Device	Package	Case	Shipping†
NB7L14MNG	QFN-16 (Pb-Free)	485G	123 Units / Tube
NB7L14MNTXG	QFN-16 (Pb-Free)	485G	3000 / Tape & Reel
NB7L14MN1TWG	QFN-16 (Pb-Free)	485AE	3000 / Tape & Reel

†For information on tape and reel specifications, including part orientation and tape sizes, please refer to our Tape and Reel Packaging Specifications Brochure, [BRD8011/D](#).

GigaComm is a trademark of Semiconductor Components Industries, LLC dba "onsemi" or its affiliates and/or subsidiaries in the United States and/or other countries.

MECHANICAL CASE OUTLINE

PACKAGE DIMENSIONS

ON Semiconductor®



1
SCALE 2:1

QFN16 3x3, 0.5P
CASE 485AE
ISSUE C

DATE 24 JUN 2016

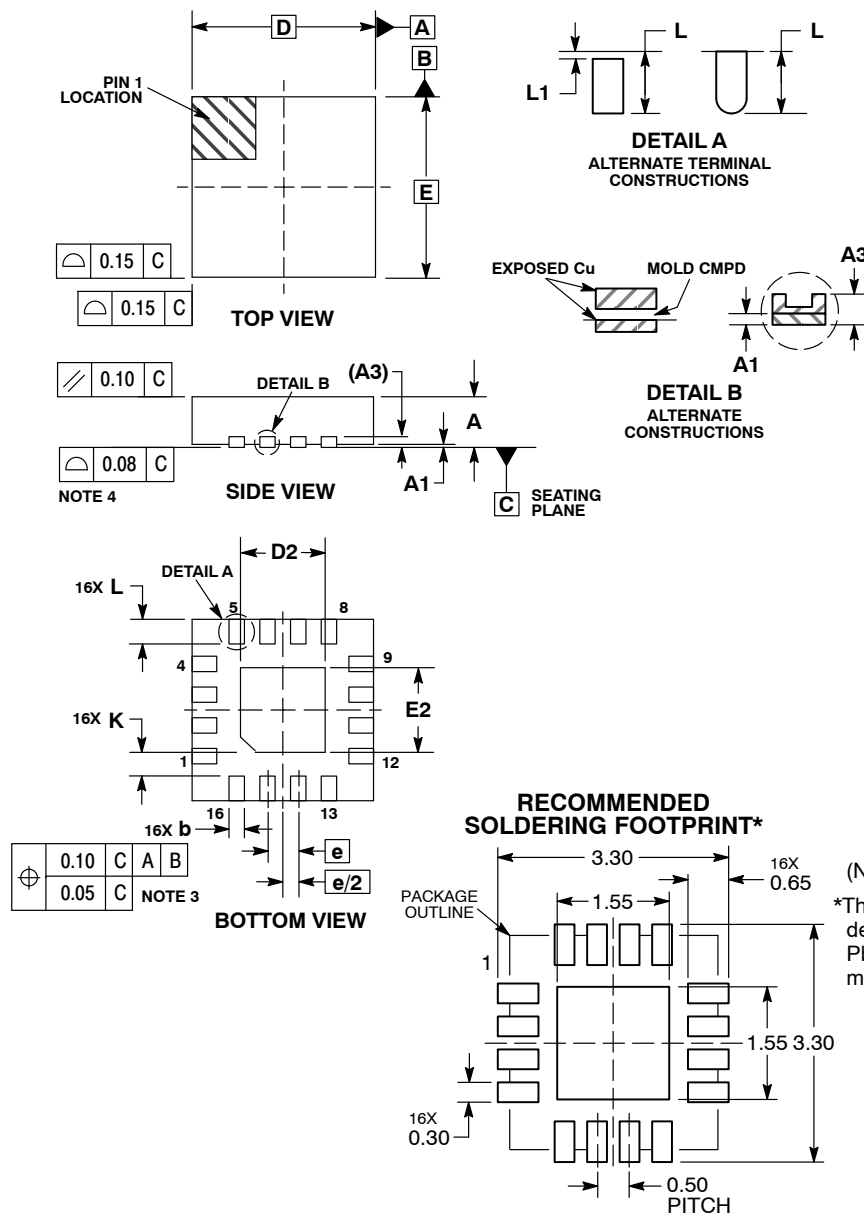

- NOTES:
1. DIMENSIONING AND TOLERANCING PER ASME Y14.5M, 1994.
 2. CONTROLLING DIMENSION: MILLIMETERS.
 3. DIMENSION b APPLIES TO PLATED TERMINAL AND IS MEASURED BETWEEN 0.25 AND 0.30 MM FROM TERMINAL.
 4. COPLANARITY APPLIES TO THE EXPOSED PAD AS WELL AS THE TERMINALS.
 5. OUTLINE MEETS JEDEC DIMENSIONS PER MO-220, VARIATION VEED-6.

DIM	MILLIMETERS	
	MIN	MAX
A	0.80	1.00
A1	0.00	0.05
A3	0.20	REF
b	0.18	0.30
D	3.00	BSC
D2	1.25	1.55
E	3.00	BSC
E2	1.25	1.55
e	0.50	BSC
K	0.20	---
L	0.30	0.50
L1	0.00	0.15

GENERIC MARKING DIAGRAM*

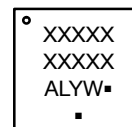

- A = Assembly Location
- L = Wafer Lot
- Y = Year
- W = Work Week
- = Pb-Free Package

(Note: Microdot may be in either location)

*This information is generic. Please refer to device data sheet for actual part marking. Pb-Free indicator, "G" or microdot "▪", may or may not be present.

RECOMMENDED SOLDERING FOOTPRINT*

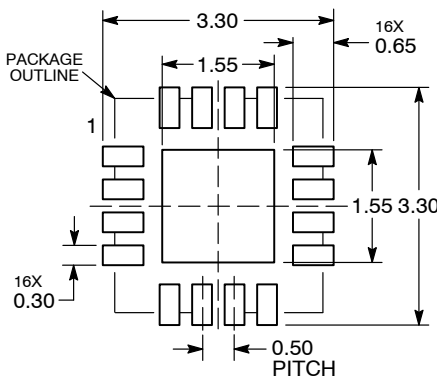

DIMENSIONS: MILLIMETERS

*For additional information on our Pb-Free strategy and soldering details, please download the ON Semiconductor Soldering and Mounting Techniques Reference Manual, SOLDERRM/D.

DOCUMENT NUMBER:	98AON14949D	Electronic versions are uncontrolled except when accessed directly from the Document Repository. Printed versions are uncontrolled except when stamped "CONTROLLED COPY" in red.
DESCRIPTION:	QFN16 3X3, 0.5P	PAGE 1 OF 1

ON Semiconductor and ON are trademarks of Semiconductor Components Industries, LLC dba ON Semiconductor or its subsidiaries in the United States and/or other countries. ON Semiconductor reserves the right to make changes without further notice to any products herein. ON Semiconductor makes no warranty, representation or guarantee regarding the suitability of its products for any particular purpose, nor does ON Semiconductor assume any liability arising out of the application or use of any product or circuit, and specifically disclaims any and all liability, including without limitation special, consequential or incidental damages. ON Semiconductor does not convey any license under its patent rights nor the rights of others.

MECHANICAL CASE OUTLINE PACKAGE DIMENSIONS



SCALE 2:1

QFN16 3x3, 0.5P
CASE 485G
ISSUE G

DATE 08 OCT 2021

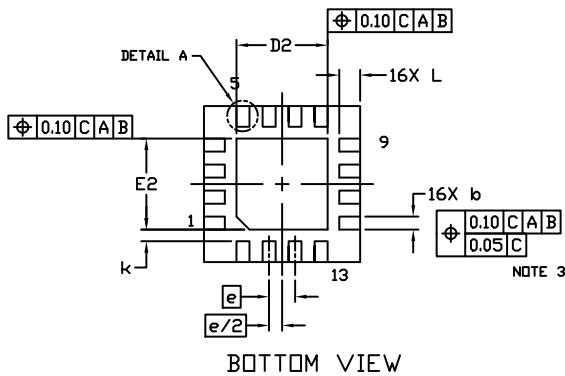
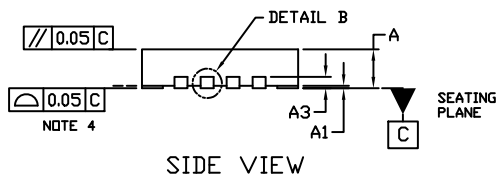
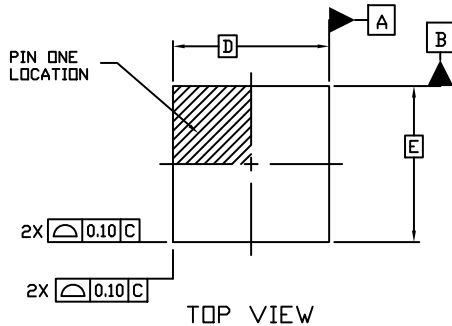

NOTES:

1. DIMENSIONING AND TOLERANCING PER ASME Y14.5M, 1994.
2. CONTROLLING DIMENSION: MILLIMETERS
3. DIMENSION *b* APPLIES TO PLATED TERMINAL AND IS MEASURED BETWEEN 0.15 AND 0.30 MM FROM THE TERMINAL TIP.
4. COPLANARITY APPLIES TO THE EXPOSED PAD AS WELL AS THE TERMINALS.

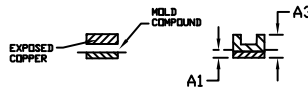

DETAIL B
ALTERNATE
CONSTRUCTIONS

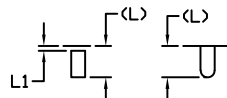

DETAIL A
ALTERNATE TERMINAL
CONSTRUCTIONS

DIM	MILLIMETERS		
	MIN.	NDM.	MAX.
A	0.80	0.90	1.00
A1	0.00	0.03	0.05
A3	0.20 REF		
<i>b</i>	0.18	0.24	0.30
D	3.00 BSC		
D2	1.65	1.75	1.85
E	3.00 BSC		
E2	1.65	1.75	1.85
<i>e</i>	0.50 BSC		
<i>k</i>	0.18 TYP		
L	0.30	0.40	0.50
L1	0.00	0.08	0.15

MOUNTING FOOTPRINT

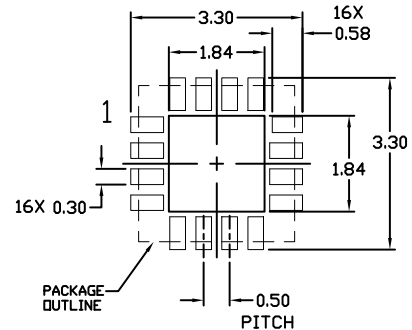

GENERIC MARKING DIAGRAM*

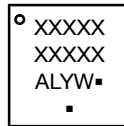

- XXXXX = Specific Device Code
- A = Assembly Location
- L = Wafer Lot
- Y = Year
- W = Work Week
- = Pb-Free Package

(Note: Microdot may be in either location)

*This information is generic. Please refer to device data sheet for actual part marking. Pb-Free indicator, "G" or microdot "▪", may or may not be present. Some products may not follow the Generic Marking.

DOCUMENT NUMBER:	98AON04795D	Electronic versions are uncontrolled except when accessed directly from the Document Repository. Printed versions are uncontrolled except when stamped "CONTROLLED COPY" in red.
DESCRIPTION:	QFN16 3X3, 0.5P	PAGE 1 OF 1

onsemi and ONSEMI are trademarks of Semiconductor Components Industries, LLC dba onsemi or its subsidiaries in the United States and/or other countries. onsemi reserves the right to make changes without further notice to any products herein. onsemi makes no warranty, representation or guarantee regarding the suitability of its products for any particular purpose, nor does onsemi assume any liability arising out of the application or use of any product or circuit, and specifically disclaims any and all liability, including without limitation special, consequential or incidental damages. onsemi does not convey any license under its patent rights nor the rights of others.

onsemi, **Onsemi**, and other names, marks, and brands are registered and/or common law trademarks of Semiconductor Components Industries, LLC dba "**onsemi**" or its affiliates and/or subsidiaries in the United States and/or other countries. **onsemi** owns the rights to a number of patents, trademarks, copyrights, trade secrets, and other intellectual property. A listing of **onsemi**'s product/patent coverage may be accessed at www.onsemi.com/site/pdf/Patent-Marking.pdf. **onsemi** reserves the right to make changes at any time to any products or information herein, without notice. The information herein is provided "as-is" and **onsemi** makes no warranty, representation or guarantee regarding the accuracy of the information, product features, availability, functionality, or suitability of its products for any particular purpose, nor does **onsemi** assume any liability arising out of the application or use of any product or circuit, and specifically disclaims any and all liability, including without limitation special, consequential or incidental damages. Buyer is responsible for its products and applications using **onsemi** products, including compliance with all laws, regulations and safety requirements or standards, regardless of any support or applications information provided by **onsemi**. "Typical" parameters which may be provided in **onsemi** data sheets and/or specifications can and do vary in different applications and actual performance may vary over time. All operating parameters, including "Typicals" must be validated for each customer application by customer's technical experts. **onsemi** does not convey any license under any of its intellectual property rights nor the rights of others. **onsemi** products are not designed, intended, or authorized for use as a critical component in life support systems or any FDA Class 3 medical devices or medical devices with a same or similar classification in a foreign jurisdiction or any devices intended for implantation in the human body. Should Buyer purchase or use **onsemi** products for any such unintended or unauthorized application, Buyer shall indemnify and hold **onsemi** and its officers, employees, subsidiaries, affiliates, and distributors harmless against all claims, costs, damages, and expenses, and reasonable attorney fees arising out of, directly or indirectly, any claim of personal injury or death associated with such unintended or unauthorized use, even if such claim alleges that **onsemi** was negligent regarding the design or manufacture of the part. **onsemi** is an Equal Opportunity/Affirmative Action Employer. This literature is subject to all applicable copyright laws and is not for resale in any manner.

ADDITIONAL INFORMATION

TECHNICAL PUBLICATIONS:

Technical Library: www.onsemi.com/design/resources/technical-documentation
onsemi Website: www.onsemi.com

ONLINE SUPPORT: www.onsemi.com/support

For additional information, please contact your local Sales Representative at www.onsemi.com/support/sales

Looking for pricing, stock, or lifecycle information?

Click below to explore more details on WIN SOURCE:

 [View NB7L14MN1TWG on WIN SOURCE](#)

 [ON Semiconductor](#) Information

Optimize Your Supply Chain with WIN SOURCE Solutions

-  Global Sourcing Solution
-  Obsolete Management
-  Cost Control Management
-  Shortage Management
-  Alternative Solution
-  Excess Inventory Management