



**THE DATASHEET OF  
LT8312HMS#PBF**





# LT8312

## ABSOLUTE MAXIMUM RATINGS

(Note 1)

EN/UVLO.....	30V
V <sub>IN</sub> .....	42V
INTV <sub>CC</sub> .....	18V
FB.....	3V
V <sub>C</sub> .....	5V
V <sub>IN(SENSE)</sub> .....	1mA
OVP.....	4V
SENSE.....	0.4V
DCM.....	±3mA
Operating Temperature Range (Note 2)....	–40°C to 125°C
Storage Temperature Range .....	–65°C to 150°C

## PIN CONFIGURATION

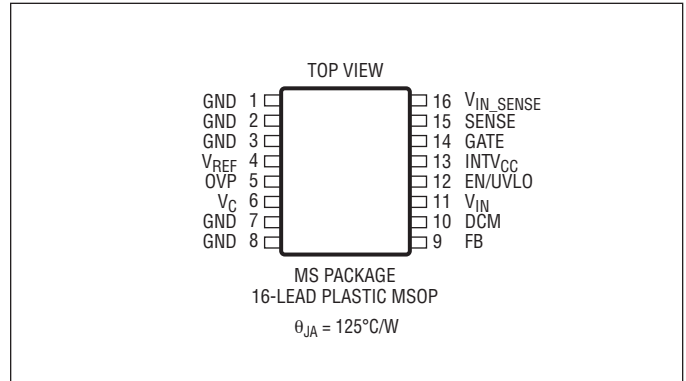

## ORDER INFORMATION

(<http://www.linear.com/product/LT8312#orderinfo>)

LEAD FREE FINISH	TAPE AND REEL	PART MARKING*	PACKAGE DESCRIPTION	TEMPERATURE RANGE
LT8312EMS#PBF	LT8312EMS#TRPBF	8312	16-Lead Plastic MSOP	–40°C to 125°C
LT8312IMS#PBF	LT8312IMS#TRPBF	8312	16-Lead Plastic MSOP	–40°C to 125°C
LT8312HMS#PBF	LT8312HMS#TRPBF	8312	16-Lead Plastic MSOP	–40°C to 150°C
LT8312MPMS#PBF	LT8312MPMS#TRPBF	8312	16-Lead Plastic MSOP	–55°C to 150°C

Consult LTC Marketing for parts specified with wider operating temperature ranges. \*The temperature grade is identified by a label on the shipping container. Consult LTC Marketing for information on nonstandard lead based finish parts.

For more information on lead free part marking, go to: <http://www.linear.com/leadfree/>

For more information on tape and reel specifications, go to: <http://www.linear.com/tapeandreeel/>

**ELECTRICAL CHARACTERISTICS** The ● denotes the specifications which apply over the full operating temperature range, otherwise specifications are at  $T_A = 25^\circ\text{C}$ .

PARAMETER	CONDITIONS		MIN	TYP	MAX	UNITS
Input Voltage Range			10		38	V
Quiescent Current	$V_{EN/UVLO} = 0.2\text{V}$ Not Switching		45	60 70	70	$\mu\text{A}$ $\mu\text{A}$
$V_{IN}$ Quiescent Current, INTV <sub>CC</sub> Overdriven	$V_{INTVCC} = 11\text{V}$			60		$\mu\text{A}$
$V_{IN}$ Shunt Regulator Voltage	$I = 1\text{mA}$			40		V
$V_{IN}$ Shunt Regulator Current Limit				8		mA
INTV <sub>CC</sub> Quiescent Current	$V_{EN/UVLO} = 0.2\text{V}$ $V_{EN/UVLO} = 1.5\text{V}$ , Not Switching		12.5 1.8	15.5 2.2	17.5 2.7	$\mu\text{A}$ mA
EN/UVLO Pin Threshold	EN/UVLO Pin Voltage Rising	●	1.21	1.25	1.29	V
EN/UVLO Pin Hysteresis Current	EN/UVLO = 1V		8	10	12	$\mu\text{A}$
$V_{REF}$ Voltage	0 $\mu\text{A}$ Load 200 $\mu\text{A}$ Load	● ●	1.97 1.95	2.0 1.98	2.03 2.03	V V
SENSE Current Limit Threshold			96	102	107	mV
Minimum SENSE Current Limit				3		mV
SENSE Input Bias Current	Current Out of Pin			15		$\mu\text{A}$
Current Sense Blanking Time			90	130	170	ns
FB Voltage		●	1.22	1.25	1.28	V
FB Voltage Line Regulation	$10\text{V} < V_{IN} < 35\text{V}$			0.01	0.03	%/V
FB Pin Bias Current	(Note 3), FB = 1.25V, OVP = 1.35V			100	600	nA
FB Error Amplifier Voltage Gain	$\Delta V_{VC}/\Delta V_{FB}$			180		V/V
FB Error Amplifier Transconductance	$\Delta I = 5\mu\text{A}$			170		$\mu\text{mhos}$
FB Low Detection Voltage				0.1		V
DCM Current Turn-On Threshold	Current Out of Pin			80		$\mu\text{A}$
Maximum Oscillator Frequency				400		kHz
<b>Linear Regulator</b>						
INTV <sub>CC</sub> Regulation Voltage			9.8	10	10.4	V
Dropout ( $V_{IN} - \text{INTV}_{CC}$ )	$I_{INTVCC} = -10\text{mA}$ , $V_{IN} = 10\text{V}$			500	900	mV
Current Limit	INTV <sub>CC</sub> < 9.5V INTV <sub>CC</sub> > 9.5V		12 80	25 120		mA mA
<b>Gate Driver</b>						
$t_r$ GATE Driver Output Rise Time	$C_L = 3300\text{pF}$			18		ns
$t_f$ GATE Driver Output Fall Time	$C_L = 3300\text{pF}$			18		ns
GATE Output Low ( $V_{OL}$ )					0.01	V
GATE Output High ( $V_{OH}$ )			INTV <sub>CC</sub> - 50mV			V

**Note 1:** Stresses beyond those listed under Absolute Maximum Ratings may cause permanent damage to the device. Exposure to any Absolute Maximum Rating condition for extended periods may affect device reliability and lifetime.

**Note 2:** The LT8312E is guaranteed to meet specified performance from 0°C to 125°C junction temperature. Specification over the -40°C and 125°C operating junction temperature range are assured by design, characterization and correlation with statistical process controls. The LT8312I is guaranteed to meet specified performance from -40°C to

125°C operating junction temperature range. The LT8312H is guaranteed to meet performance specifications over the -40°C to 150°C operating junction temperature range. The LT8312MP is guaranteed to meet performance specifications over the -55°C to 150°C operating junction temperature range. High junction temperatures degrade operating lifetimes. Operating lifetime is derated for junction temperatures greater than 125°C.

**Note 3:** Current flows out of the FB pin.

## TYPICAL PERFORMANCE CHARACTERISTICS

**EN/UVLO Threshold vs Temperature**

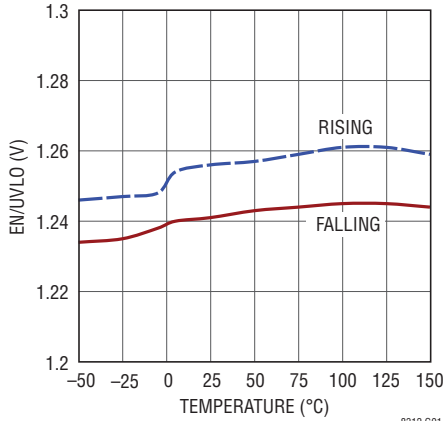

**Input Voltage Hysteresis Current vs Temperature**

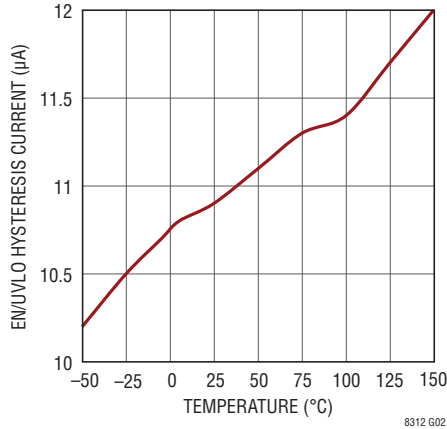

**V<sub>IN</sub> I<sub>Q</sub> vs Temperature**

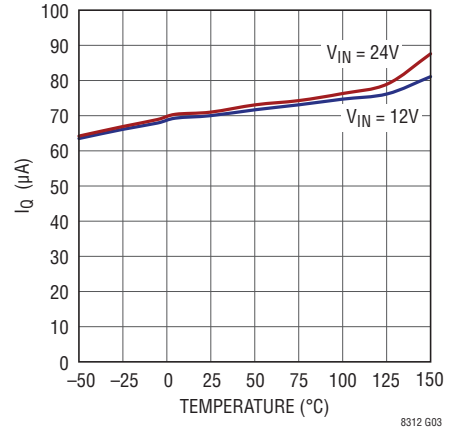

**V<sub>REF</sub> vs Temperature**

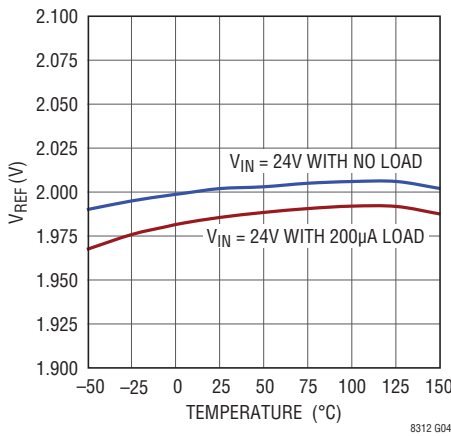

**V<sub>REF</sub> vs V<sub>IN</sub>**

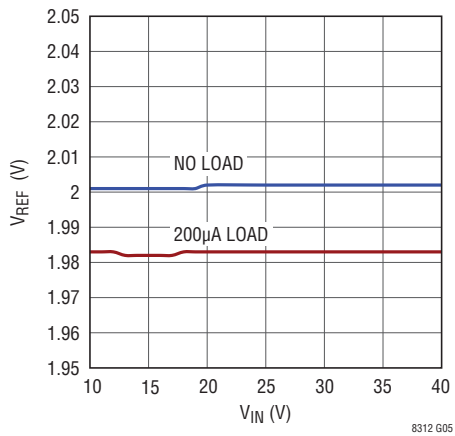

**SENSE Pin Threshold Current vs Temperature**

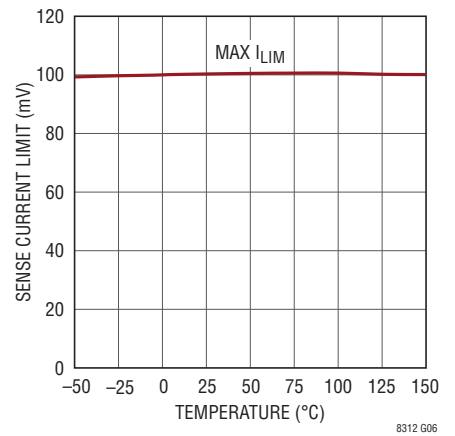

**INTV<sub>CC</sub> vs Temperature**

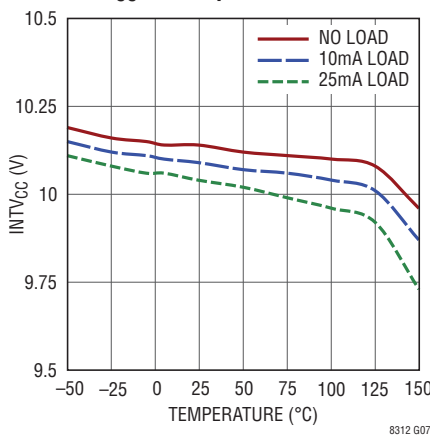

**INTV<sub>CC</sub> vs V<sub>IN</sub>**

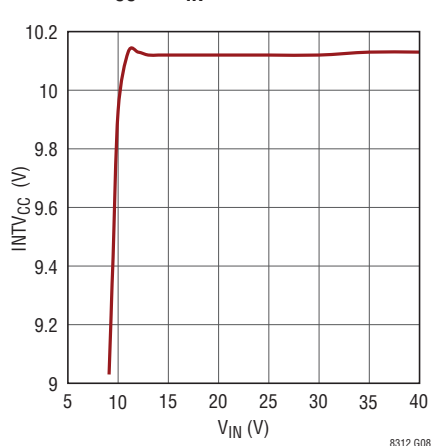

**V<sub>IN</sub> Shunt Voltage vs Temperature**

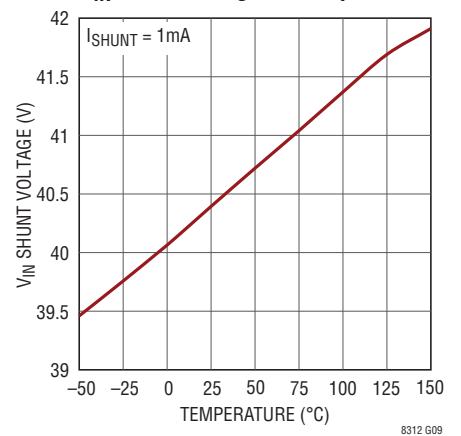

## TYPICAL PERFORMANCE CHARACTERISTICS

Maximum  $V_{IN}$  Shunt Current vs Temperature

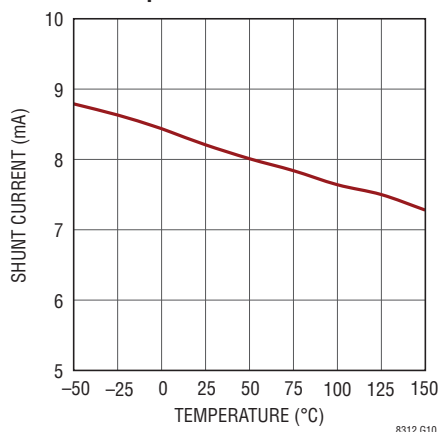

8312 G10

THD vs Output Power

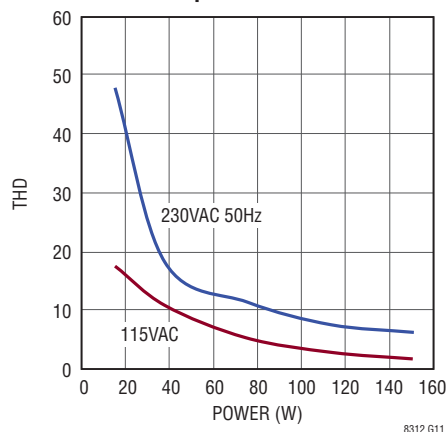

8312 G11

Power Factor vs Output Power

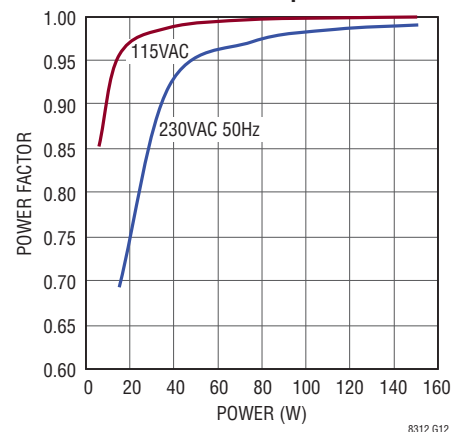

8312 G12

## PIN FUNCTIONS

**GND (Pins 1, 2, 3, 7, 8):** Ground.

**$V_{REF}$  (Pin 4):** Voltage Reference Output Pin, Typically 2V. This pin drives a resistor divider for the OVP pin. Can supply up to 200 $\mu$ A.

**OVP (Pin 5):** Overvoltage Protection. This pin accepts a DC voltage to compare to the voltage output information. When FB pin voltage is above the OVP, the part stops switching. This protects devices connected to the output.

**$V_C$  (Pin 6):** Compensation Pin for Internal Error Amplifier. Connect a series RC from this pin to ground to compensate the switching regulator. A 100pF capacitor in parallel helps eliminate noise.

**FB (Pin 9):** Voltage Loop Feedback Pin. FB is used to regulate the output voltage.

**DCM (Pin 10):** Discontinuous Conduction Mode Detection Pin. Connect a capacitor and resistor in series with this pin to the auxiliary winding.

**$V_{IN}$  (Pin 11):** Input Voltage. This pin supplies current to the internal start-up circuitry and to the INTV<sub>CC</sub> LDO. This pin must be locally bypassed with a capacitor. A 42V shunt regulator is internally connected to this pin.

**EN/UVLO (Pin 12):** Enable/Undervoltage Lockout. A resistor divider connected to  $V_{IN}$  is tied to this pin to program the minimum input voltage at which the LT8312 will turn on. When below 1.25V, the part will draw 60 $\mu$ A with most of the internal circuitry disabled and a 10 $\mu$ A hysteresis current will be pulled out of the EN/UVLO pin. When above 1.25V, the part will be enabled and begin to switch and the 10 $\mu$ A hysteresis current is turned off.

**INTV<sub>CC</sub> (Pin 13):** Regulated Supply for Internal Loads and GATE Driver. Supplied from  $V_{IN}$  and regulates to 10V (typical). INTV<sub>CC</sub> must be bypassed with a 4.7 $\mu$ F capacitor placed close to the pin.

**GATE (Pin 14):** N-Channel FET Gate Driver Output. Switches between INTV<sub>CC</sub> and GND. Driven to GND during shutdown state and stays high during low voltage states.

**SENSE (Pin 15):** The Current Sense Input for the Control Loop. Kelvin connect this pin to the positive terminal of the switch current sense resistor,  $R_{SENSE}$ , in the source of the NFET. The negative terminal of the current sense resistor should be connected to the GND plane close to the IC.

**$V_{IN(SENSE)}$  (Pin 16):** Line Voltage Sense Pin. The pin is used for sensing the AC line voltage to perform power factor correction. Connect a resistor in series with the line voltage to this pin.

**BLOCK DIAGRAM**

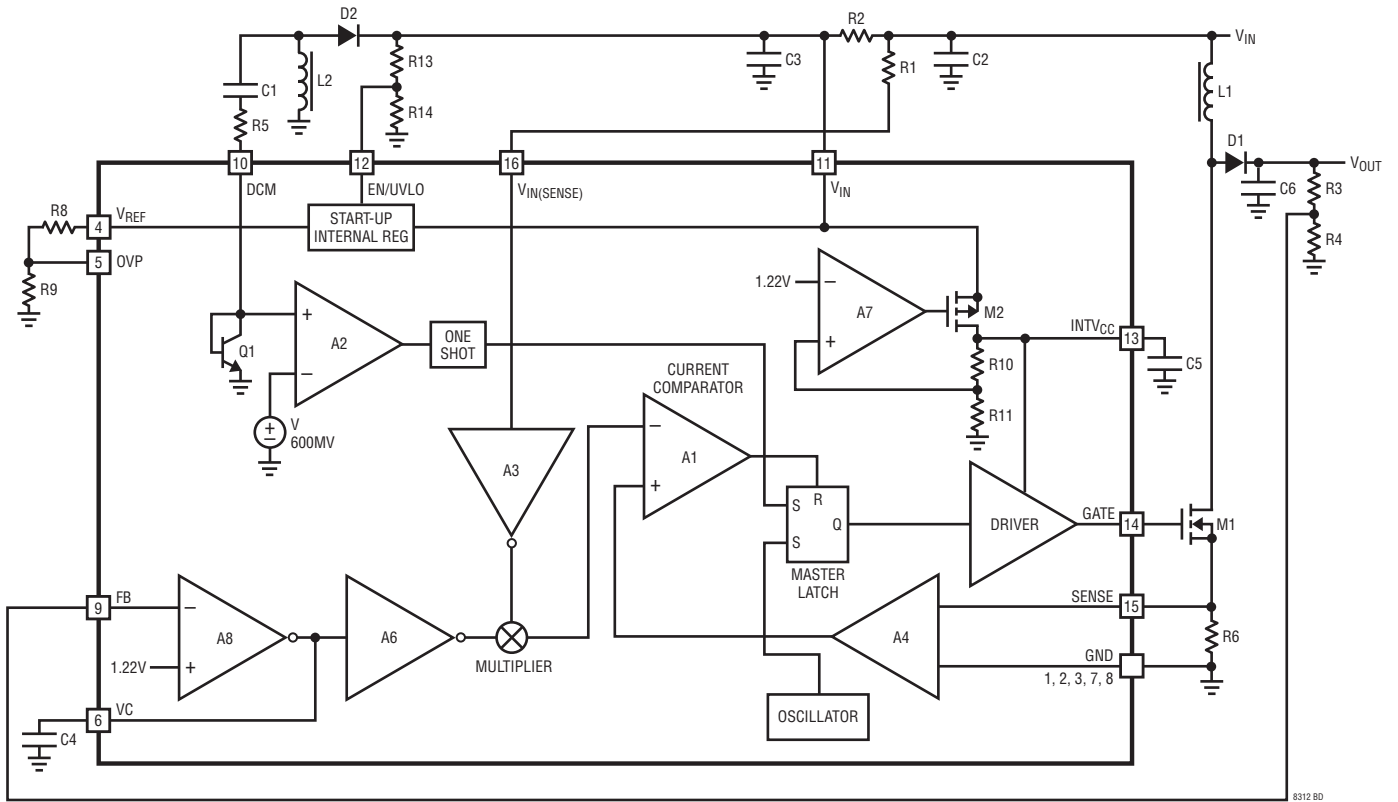

8312 BD

## OPERATION

The LT8312 is a power factor correction boost controller IC. It provides high power factor and low harmonic distortion in applications with current mode control and critical conduction mode.

Active power factor correction is becoming a requirement for offline power supplies. A power factor of one is achieved if the current drawn is proportional to the input voltage. The LT8312 modulates the peak current limit with a scaled version of the input voltage. This technique can provide power factors of 0.97 or greater.

The Block Diagram shows an overall view of the system. The external components are in a boost topology configuration. The auxiliary winding supplies power to the part in steady-state operation. The  $V_{IN}$  pin supplies power to an internal LDO that generates 10V at the  $INTV_{CC}$  pin. The control circuitry consists of an error amplifier, a multiplier, a current comparator, and a master latch, which will be explained in the following sections. A comparator is used to detect discontinuous conduction mode (DCM) with a cap connected to the auxiliary winding. The part features a 1.9A gate driver.

The LT8312 is designed for off-line applications. The EN/UVLO and a resistor divider are configured for a micropower hysteretic start-up. In the Block Diagram, R2 is used to stand off the high voltage supply voltage. The internal LDO starts to supply current to the  $INTV_{CC}$  pin when  $V_{IN}$  is above 2.5V. The  $V_{IN}$  and  $INTV_{CC}$  capacitor are charged by the current from R2. When  $V_{IN}$  exceeds the turn-on threshold and  $INTV_{CC}$  is in regulation at 10V, the part begins to switch. The  $V_{IN}$  hysteresis is set by the EN/UVLO resistor divider. The auxiliary winding provides power to  $V_{IN}$  when its voltage is higher than the  $V_{IN}$  voltage. A voltage shunt is provided for fault protection and can sink 8mA of current when  $V_{IN}$  is over 40V.

During a typical cycle, the gate driver turns the external MOSFET on and a current flows through the inductor. This current increases at a rate proportional to the input voltage. The control loop determines the maximum current and the current comparator turns the switch off when the current level is reached. When the switch turns off, the inductor current begins to flow through the diode connected to the output capacitor. This current decreases at

a rate proportional to the difference between the output voltage and the input voltage. When the current decreases to zero, the output diode turns off and the voltage on the drain of the MOSFET starts to oscillate from the parasitic capacitance and the inductor. The auxiliary winding has the same voltage across it as the main inductor and rings too. The capacitor connected to the DCM pin, C1, trips the comparator A2, which serves as a dv/dt detector, when the ringing occurs. The dv/dt detector waits for the ringing waveform to reach its minimum value and then the switch turns back on. This switching behavior is similar to zero volt switching and minimizes the amount of energy lost when the switch is turned back on and improves efficiency as much as 5%. Since this part operates on the edge of continuous conduction mode and discontinuous conduction mode, the operating mode is called critical conduction mode (or boundary conduction mode).

The output voltage is regulated with a resistor divider connected to the FB pin. The output of the error amplifier is the VC pin. This node needs a capacitor to compensate the control loop.

### Power Factor Correction

When the  $V_{IN(SENSE)}$  pin is connected to the supply voltage with a resistor, the current limit is proportional to the supply voltage. If the LT8312 is configured with a fast control loop, the VC pin would adjust to the changes of the  $V_{IN(SENSE)}$ . The only way for the multiplier to function is to set the control loop to be an order of magnitude slower than the fundamental frequency of the  $V_{IN(SENSE)}$  signal. In an offline application, the fundamental frequency of the supply voltage is 120Hz so the control loop unity gain frequency needs to be set less than approximately 12Hz.

### Start-Up

The LT8312 uses a hysteretic start-up to operate from high offline voltages. A resistor connected to the supply voltage protects the part from high voltages. This resistor is connected to the  $V_{IN}$  pin on the part and bypassed with a capacitor. When the resistor charges the  $V_{IN}$  pin to a turn-on voltage set with the EN/UVLO resistor divider and the  $INTV_{CC}$  pin is at its regulation point, the part begins to switch. The resistor cannot provide power for the part in

## OPERATION

steady state, but relies on the capacitor to start up the part, then the auxiliary winding begins to provide power to the  $V_{IN}$  pin along with the resistor. An internal voltage clamp is attached to the  $V_{IN}$  pin to prevent the resistor current from allowing  $V_{IN}$  to go above the absolute maximum voltage of the pin. The internal clamp is set at 40V and is capable of 8mA (typical) of current at room temperature.

### Setting the $V_{IN}$ Turn-On and Turn-Off Voltages

A large voltage difference between the  $V_{IN}$  turn-on voltage and the  $V_{IN}$  turn-off voltage is preferred to allow time for the auxiliary winding to power the part. The EN/UVLO sets these two voltages. The pin has a  $10\mu\text{A}$  current sink when the pins voltage is below 1.25V and  $0\mu\text{A}$  when above 1.25V. The  $V_{IN}$  pin connects to a resistor divider as shown in Figure 1.

The UVLO threshold for  $V_{IN}$  rising is:

$$V_{IN(UVLO,RISING)} = 1.25V \cdot \frac{R1+R2}{R2} + 10\mu\text{A} \cdot R1$$

The UVLO Threshold for  $V_{IN}$  Falling is :

$$V_{IN(UVLO,FALLING)} = 1.25V \cdot \frac{R1+R2}{R2}$$

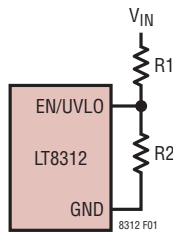

Figure 1. Undervoltage Lockout (UVLO)

### Programming Output Voltage

The output voltage is set using a resistor divider from the output capacitor to the FB pin. From the Block Diagram the resistors R3 and R4 form a resistor divider from the output capacitor. The output voltage equation is:

$$V_{OUT} = V_{BG} \cdot \frac{R3+R4}{R5}$$

The  $V_{BG}$  voltage is equal to FB Voltage in Electrical Specification Table.

### Setting $V_{IN(SENSE)}$ Resistor

The  $V_{IN(SENSE)}$  resistor sets the current feeding the internal multiplier that modulates the current limit for power factor correction. At the maximum line voltage,  $V_{MAX}$ , the current is set to  $360\mu\text{A}$ . Under this condition, the resistor value is equal to  $(V_{MAX}/360\mu\text{A})$ .

### Critical Conduction Mode Operation

Critical conduction mode is a variable frequency switching scheme that always returns the inductor current to zero with every cycle. The DCM pin uses a fast current input comparator in combination with a small capacitor to detect  $dv/dt$  on the auxiliary winding. To eliminate false tripping, a blanking time of 200ns is applied after the switch turns off. The detector looks for  $80\mu\text{A}$  of current through the DCM pin due to falling voltage on the auxiliary winding when the output diode turns off. This is not the optimal time to turn the switch on because the switch voltage is still close to  $V_{OUT}$  and would waste all the energy stored in the parasitic capacitance on the switch node. Discontinuous ringing begins when the output diode current reaches zero

## OPERATION

and the energy in the parasitic capacitance on the switch node transfers to the input capacitor. This is a second-order network composed of the parasitic capacitance on the switch node and the main inductor. The minimum voltage of the switch node during this discontinuous ring is  $2V_{IN}-V_{OUT}$ . The LT8312 turns the switch back on at this time, during the discontinuous switch waveform, by sensing when the slope of the switch waveform goes from negative to positive using the  $dv/dt$  detector. This switching technique may increase efficiency by 5%.

At low current limits, the frequency of critical conduction mode can become very high. The LT8312 features a maximum frequency clamp of 400kHz. The part operates in discontinuous conduction mode when the natural critical conduction mode frequency is higher than 400kHz.

### Sense Resistor Selection

The resistor,  $R_{SENSE}$ , between the source of the external N-channel MOSFET and GND should be selected to provide an adequate switch current to drive the application without exceeding the current limit threshold.

### Minimum Current Limit

The LT8312 features a minimum current limit of approximately 3% of the peak current limit. This helps improve the harmonic distortion during the input supplies off-line crossover period.

### Universal Input

The LT8312 operates over the universal input voltage range of 90V AC to 265V AC.

### Loop Compensation

The feedback loop is a traditional  $g_m$  error amplifier. The loop crossover frequency is set much lower than twice the line frequency for PFC to work properly. In a typical application, the compensation capacitor is  $1\mu\text{F}$ .

### MOSFET and Diode Selection

With a strong 1.9A gate driver, the LT8312 can effectively drive most high voltage MOSFETs. A low  $Q_G$  MOSFET is recommended to maximize efficiency. In most applications, the  $R_{DS(ON)}$  should be chosen to limit the temperature rise of the MOSFET. The drain of the MOSFET is stressed to  $V_{OUT}$  during the time the MOSFET is off and the diode is conducting current.

The diode is stressed to  $V_{OUT}$  when the switch is on. The average current through the diode is equal to the load current.

### Discontinuous Mode Detection

The discontinuous mode detector uses AC-coupling to detect the ringing on the auxiliary winding. A 22pF capacitor with a 30k resistor in series is recommended in most designs.

### Power Factor Correction/Harmonic Content

The LT8312 attains high power factor and low harmonic content by making the peak current of the main power switch proportional to the line voltage by using an internal multiplier. A power factor of  $>0.97$  is easily attainable for most applications by following the design equations in this data sheet. With proper design, LT8312 applications can easily meet most harmonic standards.

TYPICAL APPLICATIONS

Universal Input 150W PFC Boost Converter

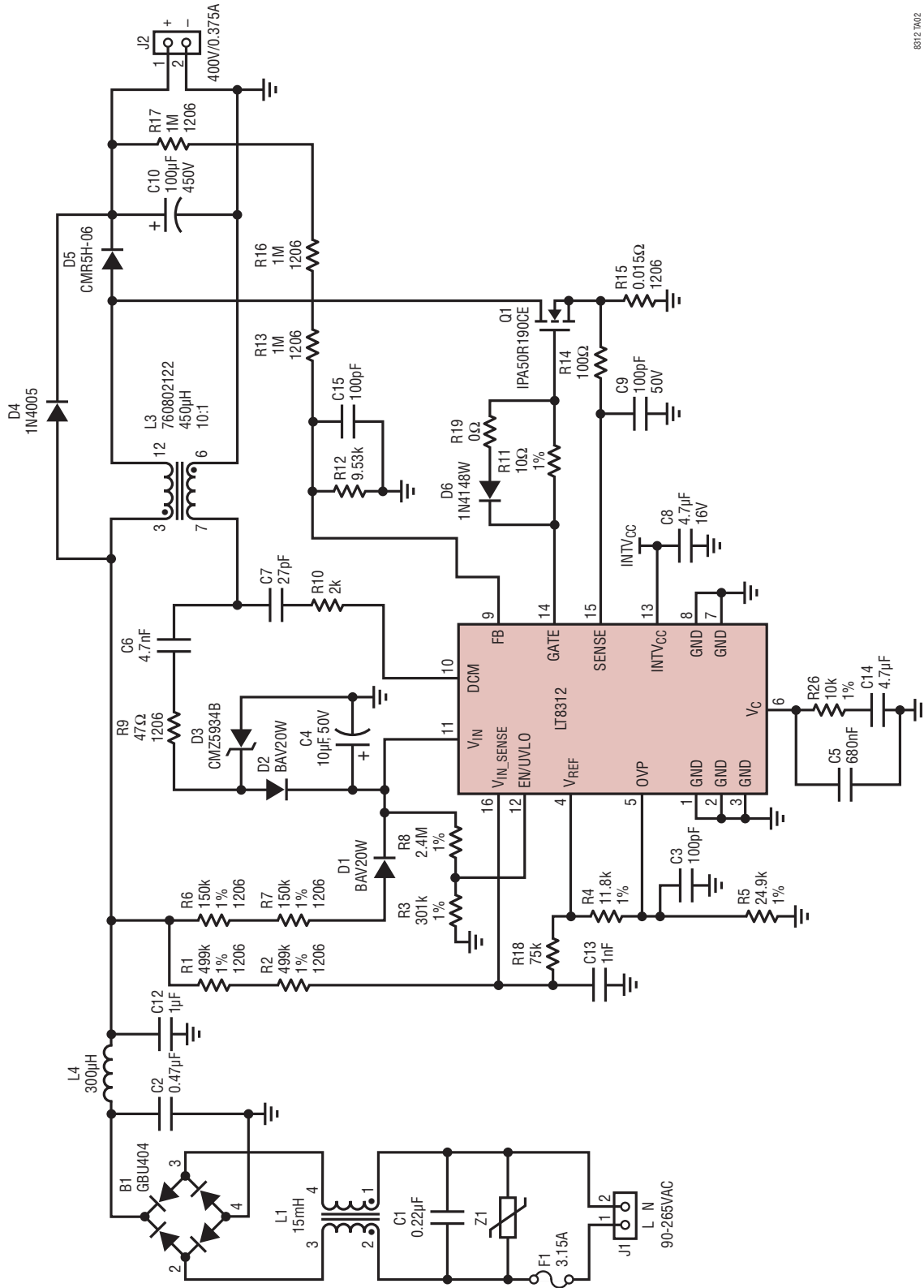

8312 TA02

TYPICAL APPLICATIONS

Avionics Input 60W PFC Boost Converter

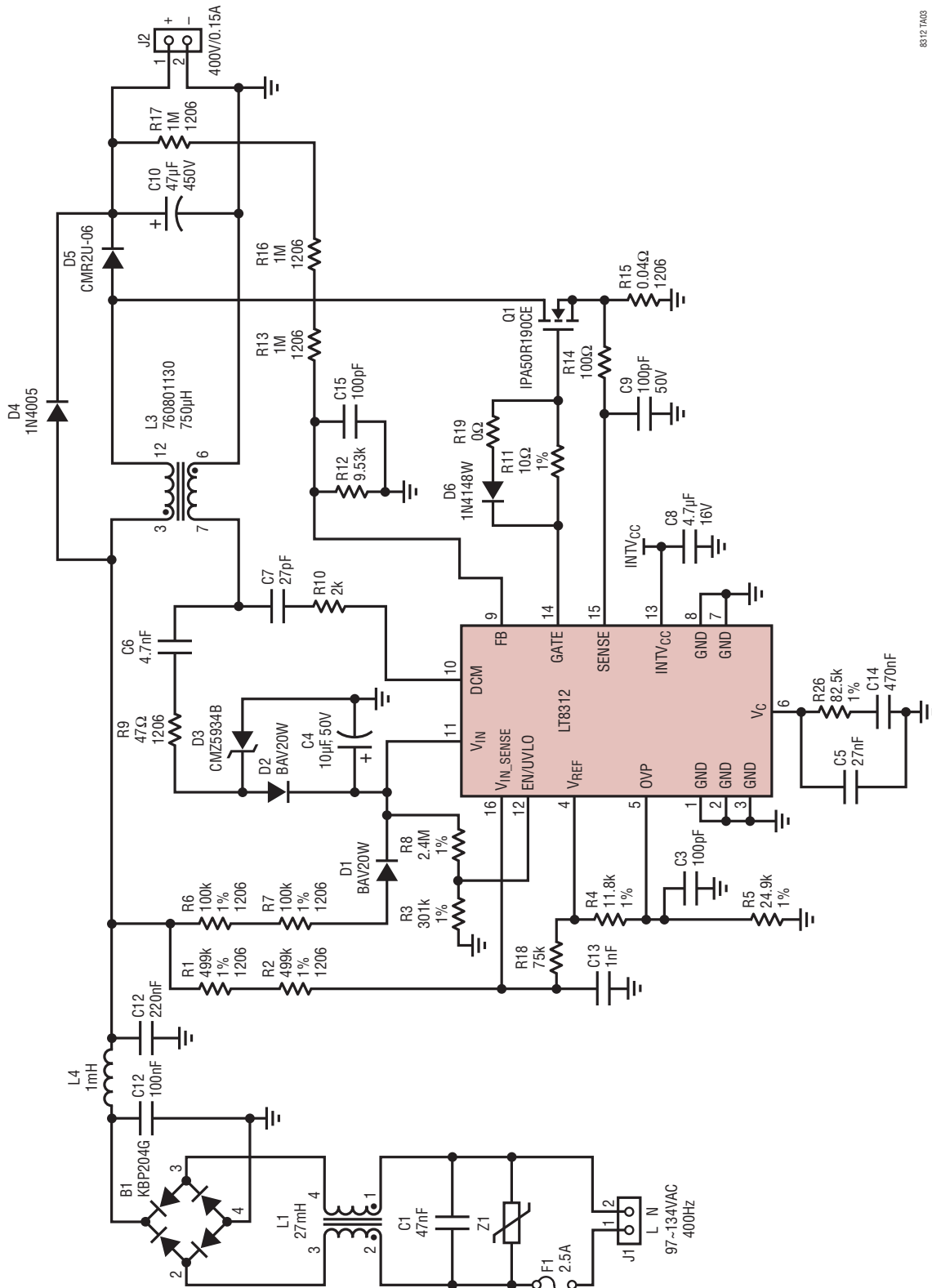

8312 TA03

## PACKAGE DESCRIPTION

Please refer to <http://www.linear.com/product/LT8312#packaging> for the most recent package drawings.

**MS Package**  
**16-Lead Plastic MSOP**  
 (Reference LTC DWG # 05-08-1669 Rev A)

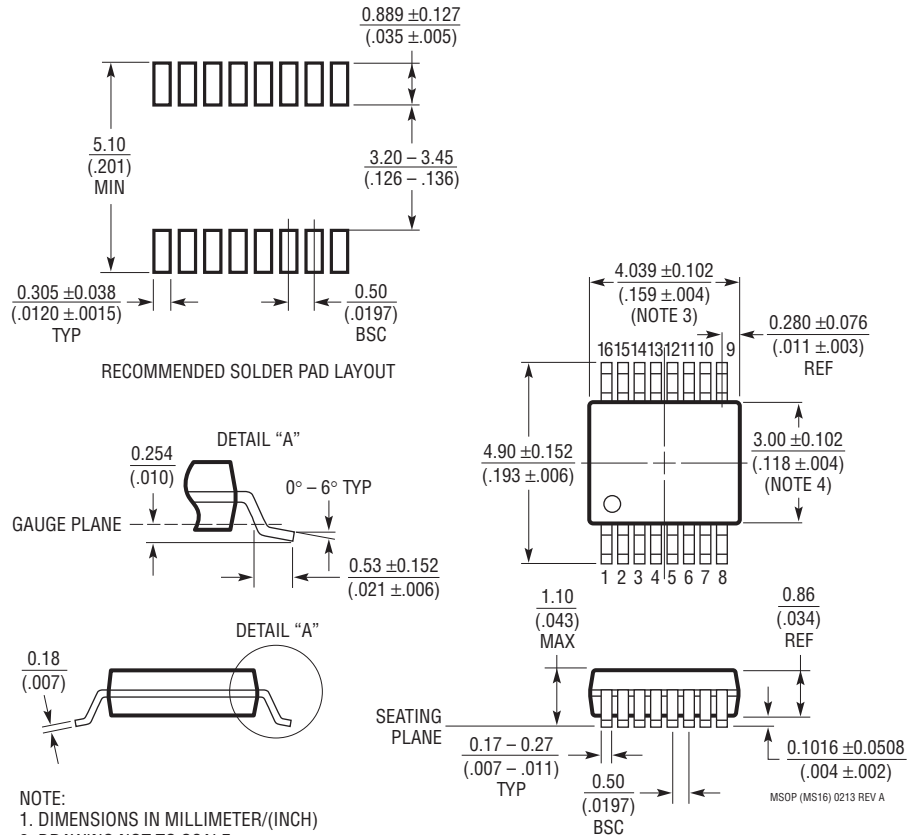

- NOTE:
1. DIMENSIONS IN MILLIMETER/(INCH)
  2. DRAWING NOT TO SCALE
  3. DIMENSION DOES NOT INCLUDE MOLD FLASH, PROTRUSIONS OR GATE BURRS.  
MOLD FLASH, PROTRUSIONS OR GATE BURRS SHALL NOT EXCEED 0.152mm (.006") PER SIDE
  4. DIMENSION DOES NOT INCLUDE INTERLEAD FLASH OR PROTRUSIONS.  
INTERLEAD FLASH OR PROTRUSIONS SHALL NOT EXCEED 0.152mm (.006") PER SIDE
  5. LEAD COPLANARITY (BOTTOM OF LEADS AFTER FORMING) SHALL BE 0.102mm (.004") MAX

## REVISION HISTORY

REV	DATE	DESCRIPTION	PAGE NUMBER
A	2/16	Modified schematics. Changed minimum current limit for INTV <sub>CC</sub> . Changed OVP pin description.	1, 14 3 6

## TYPICAL APPLICATION

Universal Input 200W PFC Boost Converter

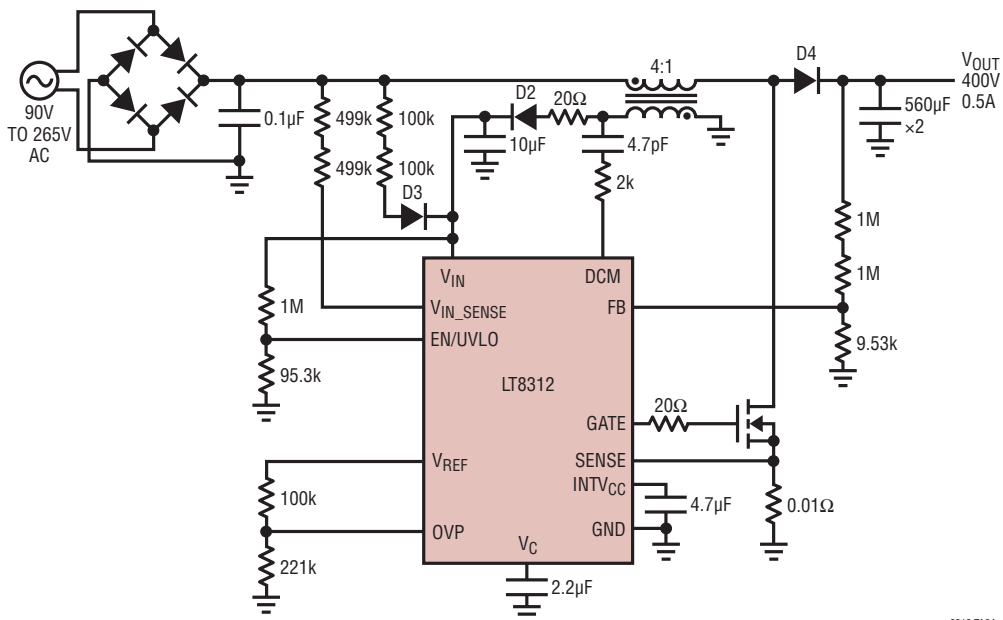

8312 TA04

## RELATED PARTS

PART NUMBER	DESCRIPTION	COMMENTS
<a href="#">LT3798</a>	Off-Line Isolated No Opto Flyback Controller with Active PFC	$V_{IN}$ and $V_{OUT}$ Limited Only By External Components
<a href="#">LT3752/</a> <a href="#">LT3752-1</a>	Active Clamp Synchronous Forward Controllers with Internal Housekeeping Controller	Input Voltage Range: LT3752: 6.5V to 100V, LT3752-1: Limited Only By Eternal Components
<a href="#">LT3753</a>	Active Clamp Synchronous Forward Controller	Input Voltage Range: 8.5V to 100V
<a href="#">LT8311</a>	Synchronous Rectifier Controller with Opto-Coupler Driver for Forward Converters	Optimized for Use with Primary-Side LT3752/LT3752-1, LT3753 and LT8310 Controllers
<a href="#">LT3748</a>	100V Isolated Flyback Controller	$5V \leq V_{IN} \leq 100V$ , No Opto Flyback, MSOP-16 with High Voltage Spacing
<a href="#">LTC®3765/</a> <a href="#">LTC3766</a>	Synchronous No Opto Forward Controller Chip Set with Active Clamp Reset	Direct Flux Limit, Supports Self Starting Secondary Forward Control
<a href="#">LTC3723-1/</a> <a href="#">LTC3723-2</a>	Synchronous Push-Pull and Full-Bridge Controllers	High Efficiency with On-Chip MOSFET Drivers, Adjustable Synchronous Rectification Timing
<a href="#">LTC3722/</a> <a href="#">LTC3722-2</a>	Synchronous Full Bridge Controllers	Adaptive or Manual Delay Control for Zero Voltage Switching, Adjustable Synchronous Rectification Timing

## Looking for pricing, stock, or lifecycle information?

Click below to explore more details on WIN SOURCE:

 [View LT8312HMS#PBF on WIN SOURCE](#)

 [Analog Devices Inc. Information](#)

## Optimize Your Supply Chain with WIN SOURCE Solutions

-  Global Sourcing Solution
-  Obsolete Management
-  Cost Control Management
-  Shortage Management
-  Alternative Solution
-  Excess Inventory Management