



**THE DATASHEET OF
EV6925-S-00A**



DESCRIPTION

The EV6925-S-00A is an evaluation board for the MP6925GS. It is configured to provide synchronous rectification solution for LLC topology.

MP6925GS features dual synchronous gate outputs which enables high efficiency rectification by replacing the schottky rectifier with a low Ron MOSFET.

ELECTRICAL SPECIFICATIONS

Parameter	Symbol	Value	Units
Vcc Voltage	V _{cc}	4.2-35	V

FEATURES

- Works with both Standard and Logic Level MOSFETs
- Compatible with Energy Star
- Fast Turn-Off Total Delay of 35ns
- Wide 4.2~35V V_{DD} Operating Range
- 175uA Low Quiescent Current in Light-Load Mode
- Supports CCM, CrCM and DCM Operation Mode
- Supports High-side and Low-side Rectification
- Available in a SOIC-8 Package

APPLICATIONS

- AC-DC Adapters
- PC Power Supplies
- LCD and LED TVs
- Isolated DC/DC Power Converters

All MPS parts are lead-free, halogen-free, and adhere to the RoHS directive. For MPS green status, please visit the MPS website under Quality Assurance. "MPS", the MPS logo, and "Simple, Easy Solutions" are trademarks of Monolithic Power Systems, Inc. or its subsidiaries.

EV6925-S-00A EVALUATION BOARD

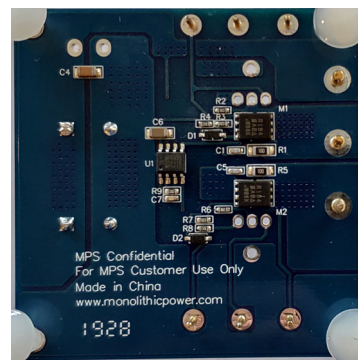
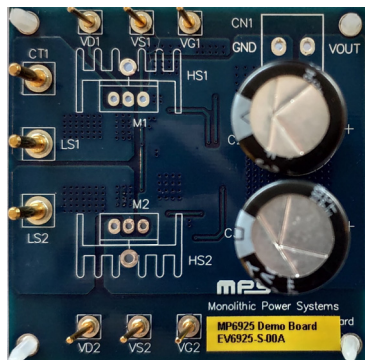

(L x W x H) 6.3cm x 6.3cm x 3cm

Board Number	MPS IC Number
EV6925-S-00A	MP6925GS

EV6925-S-00A BILL OF MATERIALS

Qty	Ref	Value	Description	Package	Manufacturer	Part Number
2	C1, C5	100pF	Ceramic Capacitor, 100V, C0G	0603	TDK	C1608C0G2A101J
2	C2, C3	2200µF	Electrolytic Capacitor, 35V	DIP	Rubycon	2200uF/35V Dia.16mm
1	C4	10µF	Ceramic Capacitor, 35V, X7R	1206	TDK	C3216X7R1V106K
1	C6	2.2µF	Ceramic Capacitor, 50V, X7R	1206	muRata	GRM31CR71H225KA88L
1	C7	1nF	Ceramic Capacitor, 50V, X7R	0603	muRata	GRM188R71H102KA01D
2	D1, D2		Diode;75V, 0.15A	SOD-123	Diodes	1N4148W
2	M1, M2	NS	N Channel Mosfet, 60V	TO-220		
			N Channel Mosfet, 60V	PowerPAK SO-8	Si7478DP	Si7478DP
2	R1, R5	10	Film Resistor, 5%	1206	Yageo	RC1206JR-0710R
2	R2, R6	1k	Film Resistor, 5%	0603	Royalohm	0603SAJ0102T5E
2	R3, R7	10k	Film Resistor, 5%	0603	Yageo	RC0603JR-0710KL
2	R4, R8	10	Film Resistor, 5%	0603	Royalohm	0603SAJ0100T5E
1	R9	100k	Film Resistor, 1%	0603	Yageo	RC0603FR-07100KL
1	U1		SR Controller	SO-8	MPS	MP6925GS
6	VD1,VD2,VS1,VS2,VG1,VG2		1.0mm copper cylinder			
3	CT1,LS1,LS2		2.0mm copper cylinder			
4			plastic pillar			

EVB TEST RESULTS

Performance waveforms are tested on the evaluation board.
 $V_{DD} = 12V$, unless otherwise noted.

Operation in 90W LLC Converter

$V_{IN} = 240V_{AC}$, $V_{OUT} = 12V$, $I_{OUT} = 0.75A$

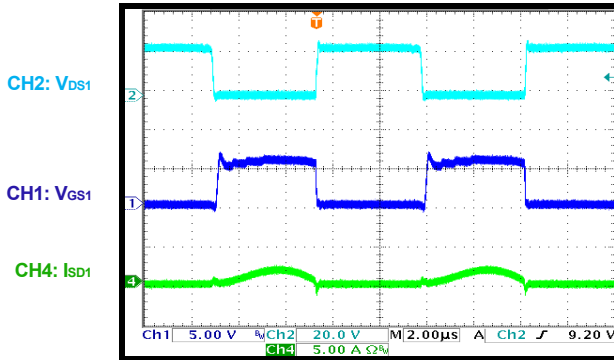

Operation in 90W LLC Converter

$V_{IN} = 240V_{AC}$, $V_{OUT} = 12V$, $I_{OUT} = 0.75A$

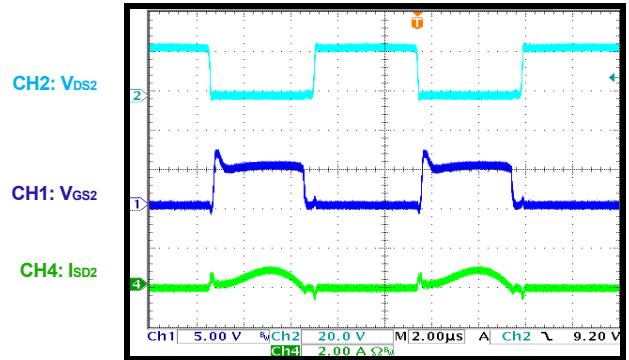

Operation in 90W LLC Converter

$V_{IN} = 240V_{AC}$, $V_{OUT} = 12V$, $I_{OUT} = 7.5A$

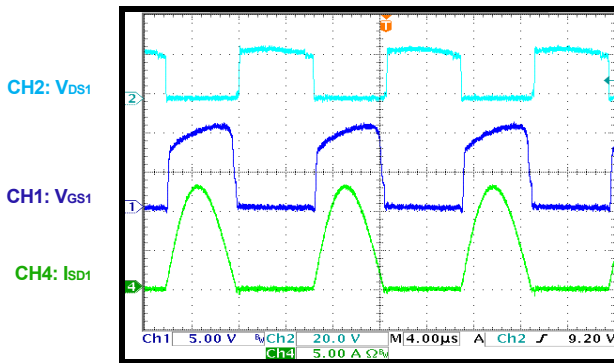

Operation in 90W LLC Converter

$V_{IN} = 240V_{AC}$, $V_{OUT} = 12V$, $I_{OUT} = 7.5A$

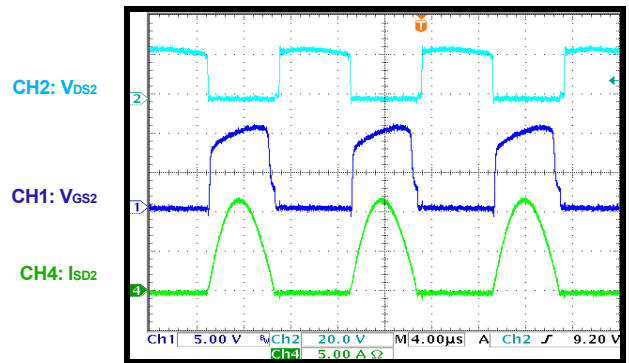

PRINTED CIRCUIT BOARD LAYOUT

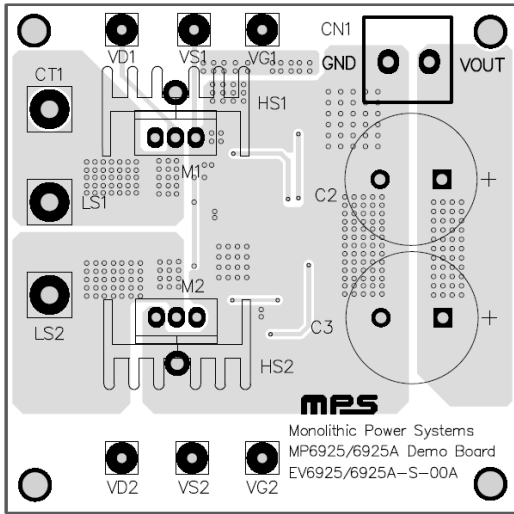

Figure 1: Top Layer

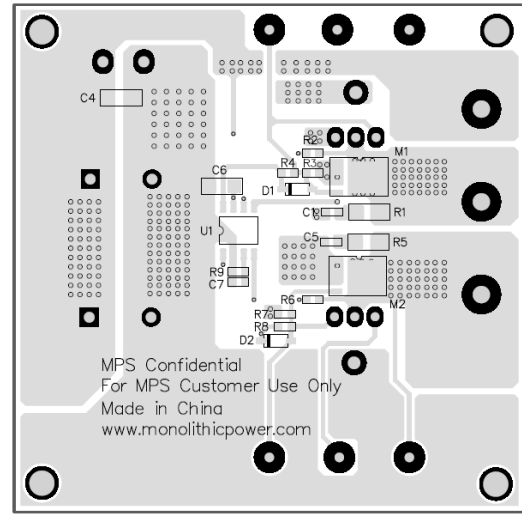

Figure 2: Bottom Layer

QUICK START GUIDE

The demo board is intended to implement the synchronous rectifier in an LLC resonant converter with center-tap secondary winding.

How to use EV6925-S-00A evaluation board replace diode rectification:

1. Remove the diodes rectifiers from the board as the Fig.3 shows.
2. Connect the center-tap and other two secondary windings of transformer as the Fig.4 shows.
3. Connect the Vout and GND pins on MP6925 demo board as the Fig. 4 shows.
4. Turn the power supply on. The IC will start up automatically.

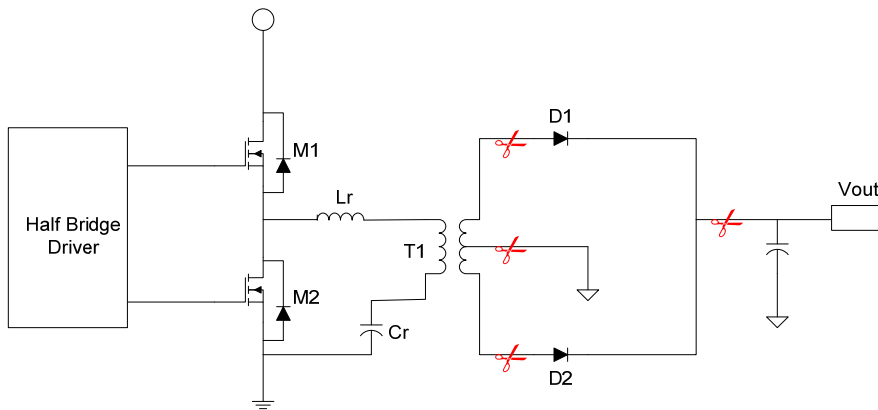

Figure 3: How to disconnect the diode rectifiers

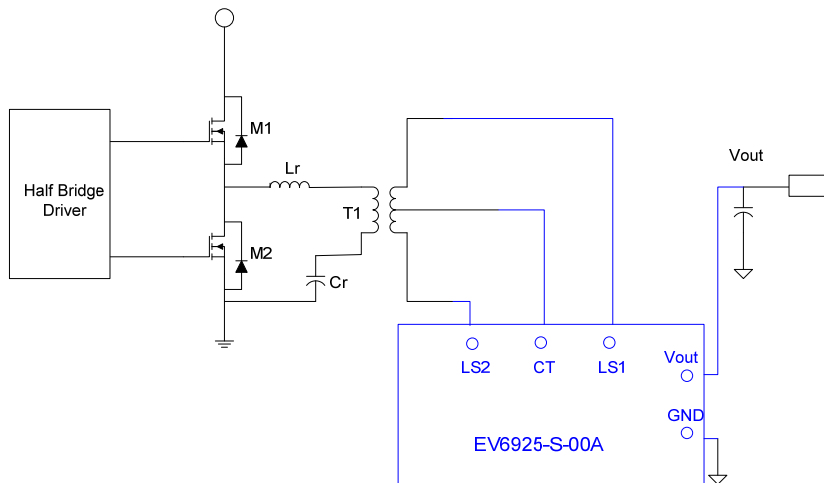



Figure 4: How to connect the EV6925-S-00A

NOTICE: The information in this document is subject to change without notice. Please contact MPS for current specifications. Users should warrant and guarantee that third-party Intellectual Property rights are not infringed upon when integrating MPS products into any application. MPS will not assume any legal responsibility for any said applications.

Looking for pricing, stock, or lifecycle information?

Click below to explore more details on WIN SOURCE:

-  [View EV6925-S-00A on WIN SOURCE](#)
-  [Monolithic Power Systems Inc. Information](#)

Optimize Your Supply Chain with WIN SOURCE Solutions

-  Global Sourcing Solution
-  Obsolete Management
-  Cost Control Management
-  Shortage Management
-  Alternative Solution
-  Excess Inventory Management