



**THE DATASHEET OF
TL4242DRJR-P**



TL4242 500-mA, Adjustable, Constant-Current LED Driver

1 Features

- Adjustable Constant Current up to 500 mA ($\pm 5\%$)
- PWM Brightness Regulation
- Wide Input Voltage Range up to 42 V
- Low Drop Voltage
- Open-Load Detection
- Overtemperature Protection
- Short-Circuit Proof
- Reverse-Polarity Proof
- Wide Temperature Range: -40°C to 150°C

2 Applications

- Signage
- Industrial Lighting
- Printers

3 Description

The TL4242 device is an integrated, adjustable, constant-current source that can drive loads up to 500 mA. The output current level can be adjusted through an external resistor. The device is designed to supply high-power LEDs. The TL4242 is provided in the DRJ (WSON) package. Protection circuits prevent damage to the device in case of overload, short circuit, reverse polarity, and overtemperature. The connected LEDs are protected against reverse polarity as well as excess voltages up to 45 V.

The integrated PWM input of the TL4242 permits LED brightness regulation by pulse-width modulation (PWM). Due to the high input impedance of the PWM input, the LED driver can be operated as a protected high-side switch.

The TL4242 is characterized for operation from -40°C to 150°C .

Device Information⁽¹⁾

PART NUMBER	PACKAGE	BODY SIZE (NOM)
TL4242	WSON (8)	4.00 mm x 4.00 mm

(1) For all available packages, see the orderable addendum at the end of the data sheet.

Simplified Schematic

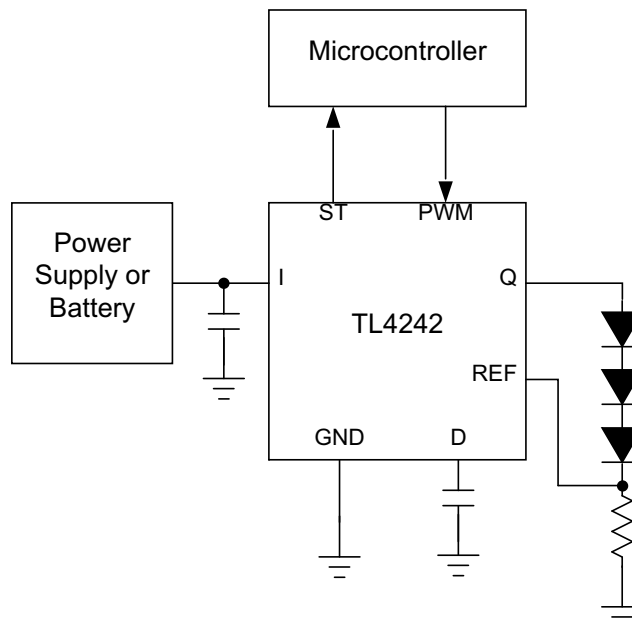

Table of Contents

1 Features	1	7.3 Feature Description.....	7
2 Applications	1	7.4 Device Functional Modes.....	8
3 Description	1	8 Application and Implementation	9
4 Revision History	2	8.1 Application Information.....	9
5 Pin Configuration and Functions	3	8.2 Typical Application	10
6 Specifications	3	9 Power Supply Recommendations	12
6.1 Absolute Maximum Ratings	3	10 Layout	12
6.2 ESD Ratings.....	4	10.1 Layout Guidelines	12
6.3 Recommended Operating Conditions.....	4	10.2 Layout Example	12
6.4 Thermal Information	4	11 Device and Documentation Support	13
6.5 Electrical Characteristics.....	4	11.1 Trademarks	13
6.6 Typical Characteristics.....	6	11.2 Electrostatic Discharge Caution.....	13
7 Detailed Description	7	11.3 Glossary	13
7.1 Overview	7	12 Mechanical, Packaging, and Orderable Information	13
7.2 Functional Block Diagram	7		

4 Revision History

Changes from Revision A (April 2011) to Revision B

Page

- | | |
|---|----------|
| <ul style="list-style-type: none"> Added <i>ESD Ratings</i> table, <i>Feature Description</i> section, <i>Device Functional Modes</i>, <i>Application and Implementation</i> section, <i>Power Supply Recommendations</i> section, <i>Layout</i> section, <i>Device and Documentation Support</i> section, and <i>Mechanical, Packaging, and Orderable Information</i> section. | 1 |
|---|----------|

5 Pin Configuration and Functions

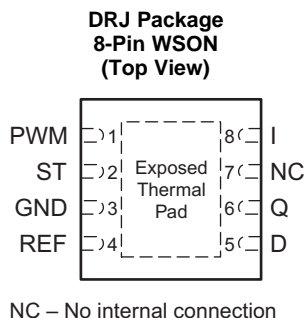

Pin Functions

PIN		I/O	DESCRIPTION
NO.	NAME		
1	PWM	I	Pulse-width modulation input. If not used, connect to I.
2	ST	O	Status output. Open-collector output. Connect to an external pullup resistor ($R_{PULLUP} \geq 4.7 \text{ k}\Omega$).
3	GND	—	Ground
4	REF	I	Reference input. Connect to a shunt resistor.
5	D	I	Status delay. To set status reaction delay, connect to GND with a capacitor. If no delay is needed, leave open.
6	Q	O	Output
7	NC	—	No internal connection
8	I	I	Input. Connect directly to GND as close as possible to the device with a 100-nF ceramic capacitor.
—	Thermal Pad	—	The thermal pad must be soldered directly to the PCB. It may be connected to ground or left floating.

6 Specifications

6.1 Absolute Maximum Ratings

over operating free-air temperature range (unless otherwise noted)⁽¹⁾

		MIN	MAX	UNIT	
V_{CC}	Supply voltage ⁽²⁾	–42	45	V	
V_I	Input voltage	D	–0.3	7	V
		PWM	–40	40	
		REF	–1	16	
V_O	Output voltage	Q	–1	41	V
		ST	–0.3	40	
I_O	Output current	PWM		± 1	mA
		REF		± 2	
		ST		± 5	
T_J	Virtual-junction temperature	–40	150	°C	
T_{stg}	Storage temperature	–50	150	°C	

- (1) Stresses beyond those listed under *Absolute Maximum Ratings* may cause permanent damage to the device. These are stress ratings only, and functional operation of the device at these or any other conditions beyond those indicated under *Recommended Operating Conditions* is not implied. Exposure to absolute-maximum-rated conditions for extended periods may affect device reliability.
- (2) All voltage values are with respect to the network ground terminal.

6.2 ESD Ratings

		VALUE	UNIT
$V_{(ESD)}$	Electrostatic discharge	Human-body model (HBM), per ANSI/ESDA/JEDEC JS-001 ⁽¹⁾	V
		Charged-device model (CDM), per JEDEC specification JESD22-C101 ⁽²⁾	
		±1000	
		±1000	

(1) JEDEC document JEP155 states that 500-V HBM allows safe manufacturing with a standard ESD control process.

(2) JEDEC document JEP157 states that 250-V CDM allows safe manufacturing with a standard ESD control process.

6.3 Recommended Operating Conditions

		MIN	MAX	UNIT
V_{CC}	Supply voltage	4.5	42	V
V_{ST}	Status (ST) output voltage		16	V
V_{PWM}	PWM voltage	0	40	V
C_D	Status delay (D) capacitance	0	2.2	μF
R_{REF}	Reference (REF) resistor	0	10	Ω
T_J	Virtual-junction temperature	-40	150	°C

6.4 Thermal Information

THERMAL METRIC ⁽¹⁾		TL4242	UNIT
		DRJ (WSON)	
		8 PINS	
$R_{\theta JA}$	Junction-to-ambient thermal resistance	39.0	°C/W
$R_{\theta JC(top)}$	Junction-to-case (top) thermal resistance	31.5	
$R_{\theta JB}$	Junction-to-board thermal resistance	15.5	
Ψ_{JT}	Junction-to-top characterization parameter	0.3	
Ψ_{JB}	Junction-to-board characterization parameter	15.6	
$R_{\theta JC(bot)}$	Junction-to-case (bottom) thermal resistance	1.8	

(1) For more information about traditional and new thermal metrics, see the *IC Package Thermal Metrics* application report, [SPRA953](#).

6.5 Electrical Characteristics

over recommended operating free-air temperature range, $V_I = 13.5$ V, $R_{REF} = 0.47$ Ω, $V_{PWM,H}$, $T_J = -40$ °C to 150°C, all voltages with respect to ground (unless otherwise noted)

PARAMETER		TEST CONDITIONS	MIN	TYP	MAX	UNIT
I_{qL}	Supply current	$V_Q = 6.6$ V		12	22	mA
I_{qOFF}	Supply current, off mode	PWM = L, $T_J < 85$ °C		0.1	2	μA
OUTPUT ELECTRICAL CHARACTERISTICS						
I_Q	Output current	$V_Q - V_{REF}^{(1)} = 6.6$ V	357	376	395	mA
		$V_Q - V_{REF} = 6.6$ V, $R_{REF} = 1$ Ω	168	177	185	
		$V_Q - V_{REF} = 6.6$ V, $R_{REF} = 0.39$ Ω	431	454	476	
		$V_Q - V_{REF} = 5.4$ V to 7.8 V, $V_I = 9$ V to 16 V	357	376	395	
I_{Qmax}	Output current limit	$R_{REF} = 0$ Ω		600		mA
V_{dr}	Drop voltage	$I_Q = 300$ mA		0.35	0.7	V
PWM INPUT ELECTRICAL CHARACTERISTICS						
$V_{PWM,H}$	High-level PWM voltage		2.6			V
$V_{PWM,L}$	Low-level PWM voltage				0.7	V
$I_{PWM,H}$	High-level PWM input current	$V_{PWM} = 5$ V		220	500	μA
$I_{PWM,L}$	Low-level PWM input current	$V_{PWM} = 0$ V	-1		1	μA

(1) $V_Q - V_{REF}$ equals the forward voltage sum of the connected LEDs (see [Figure 3](#)).

Electrical Characteristics (continued)

over recommended operating free-air temperature range, $V_I = 13.5\text{ V}$, $R_{REF} = 0.47\ \Omega$, $V_{PWM,H}$, $T_J = -40^\circ\text{C}$ to 150°C , all voltages with respect to ground (unless otherwise noted)

PARAMETER		TEST CONDITIONS	MIN	TYP	MAX	UNIT
t_{PWN}	Delay time, turn on	70% of I_{Qnom} , See Figure 5	0	15	40	μs
t_{PWF}	Delay time, turn off	30% of I_{Qnom} , See Figure 5	0	15	40	μs
REFERENCE (REF) ELECTRICAL CHARACTERISTICS						
V_{REF}	Reference voltage	$R_{REF} = 0.39\ \Omega$ to $1\ \Omega$	168	177	185	mV
I_{REF}	Reference input current	$V_{REF} = 180\text{ mV}$	-1	0.1	1	μA
STATUS OUTPUT (ST) ELECTRICAL CHARACTERISTICS						
V_{IQL}	Lower status-switching threshold	ST = L	15	25		mV
V_{IQH}	Upper status-switching threshold	ST = H		30	40	mV
V_{STL}	Low-level status voltage	$I_{ST} = 1.5\text{ mA}$			0.4	V
I_{STLK}	Leakage current	$V_{ST} = 5\text{ V}$			5	μA
STATUS DELAY (D) ELECTRICAL CHARACTERISTICS						
t_{STHL}	Delay time, status reaction	$C_D = 47\text{ nF}$, ST H→L	6	10	14	ms
t_{STLH}	Delay time, status release	$C_D = 47\text{ nF}$, ST L→H		10	20	μs

6.6 Typical Characteristics

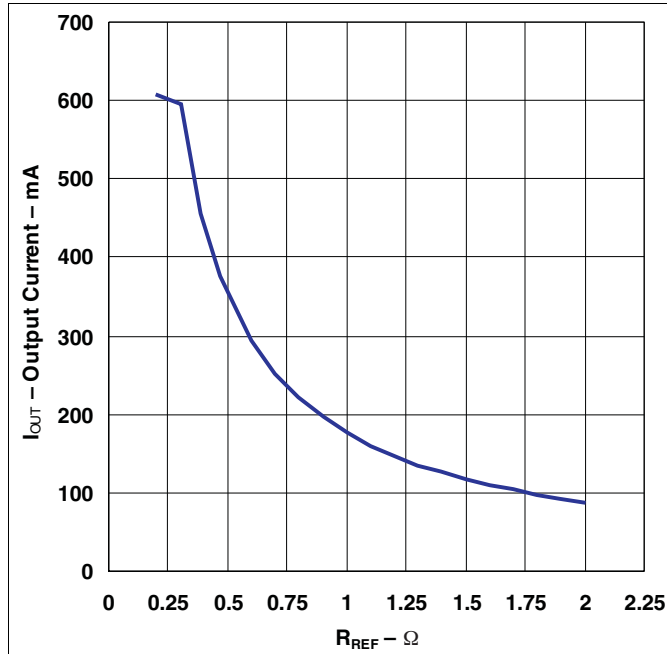

Figure 1. Output Current vs External Resistor

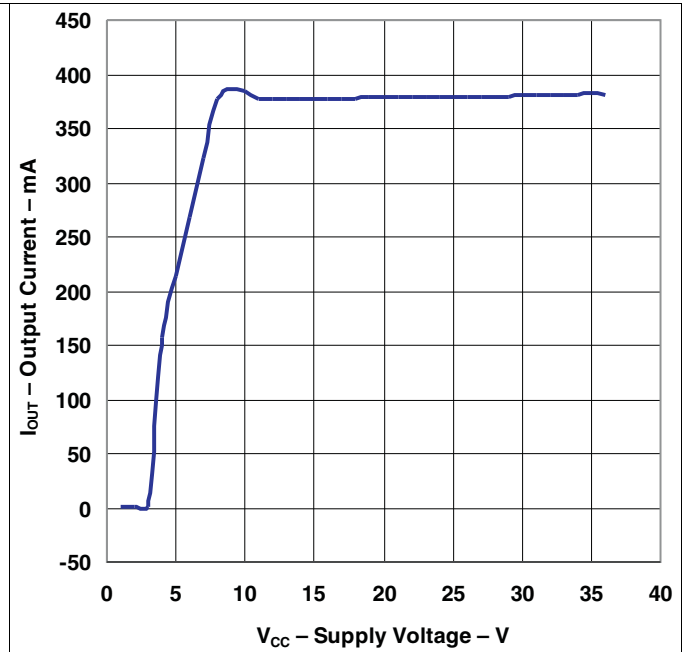

Figure 2. Output Current vs Supply Voltage

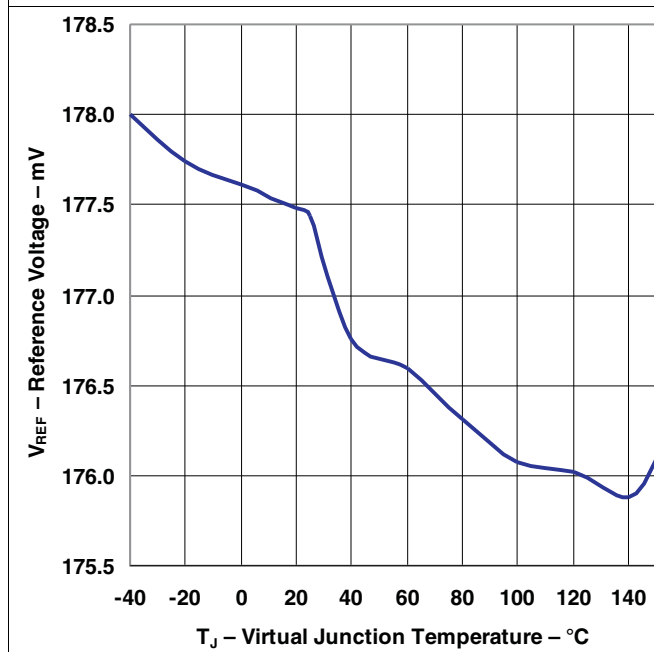

Figure 3. Reference Voltage vs Junction Temperature

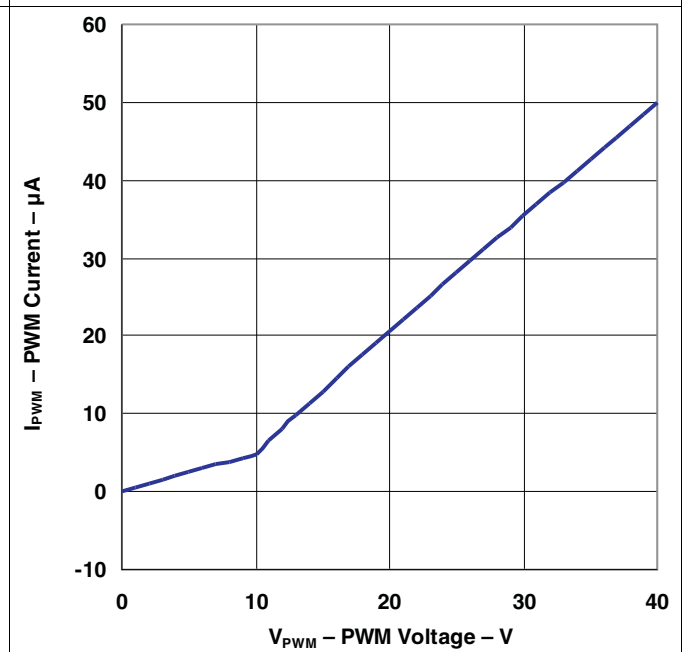

Figure 4. PWM Pin Input Current vs PWM Voltage

7 Detailed Description

7.1 Overview

The TL4242 device is an integrated, adjustable, constant-current source that can drive loads up to 500 mA. The output current level can be adjusted through an external resistor. The device is designed to supply high-power LEDs. Protection circuits prevent damage to the device in case of overload, short circuit, reverse polarity, and overtemperature. The connected LEDs are protected against reverse polarity as well as excess voltages up to 45 V. The integrated PWM input of the TL4242 permits LED brightness regulation by pulse-width modulation (PWM). Due to the high input impedance of the PWM input, the LED driver can be operated as a protected high-side switch.

7.2 Functional Block Diagram

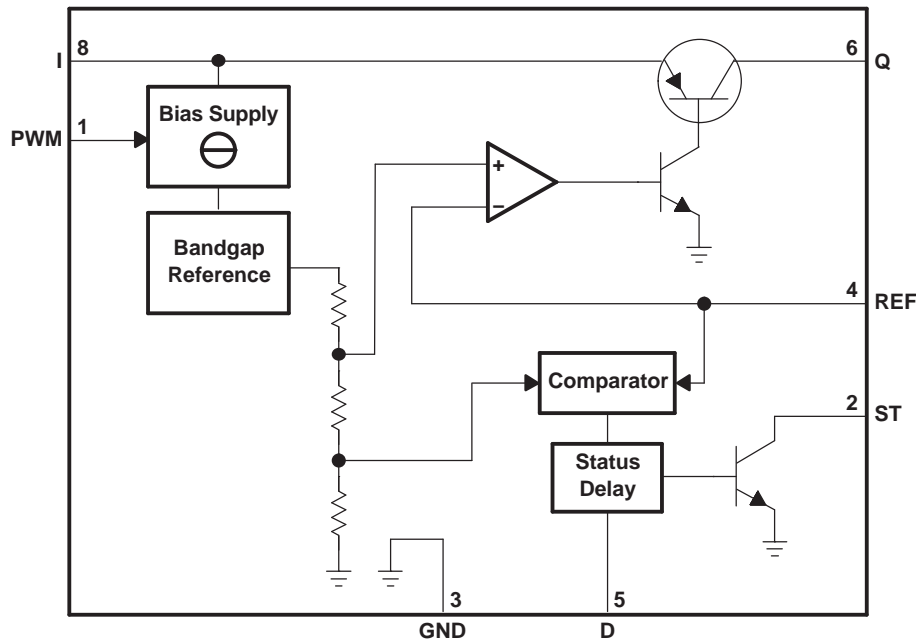

7.3 Feature Description

7.3.1 PWM Input

The integrated PWM input of the TL4242 permits LED brightness regulation by pulse-width modulation (PWM). The overall LED brightness is a function of the shunt resistor, R_{REF} , and the PWM duty cycle. The PWM input can also function as a simple enable control. When the PWM input is below $V_{PWM,L}$, the device will go to a low-power consumption sleep mode. Due to the high input impedance of the PWM input, the LED driver can be operated as a protected high-side switch.

The LEDs are driven by a supply current that is adjusted by the resistor, R_{REF} , preventing brightness variations due to forward voltage spread of the LEDs. The luminosity spread arising from the LED production process can be compensated through software by an appropriate duty cycle applied to the PWM pin. Therefore, it is not necessary to select LEDs for forward voltage or luminosity classes.

7.3.2 ST Output

The status output of the LED driver (ST) detects an open-load condition, enabling supervision of correct LED operation. An LED failure is detected as a voltage drop at the shunt resistor (R_{REF}) below 25 mV (typical). In this case, the status output pin (ST) is set low after a delay time adjustable by an optional capacitor connected to pin D.

Feature Description (continued)

7.3.2.1 Function and Timing Diagram

The functionality and timing of ST and PWM are shown in [Figure 5](#). The status delay can be adjusted through the capacitor connected to pin D. Delay time scales linearly with capacitance, C_D :

$$t_{\text{STHL,typ}} = \frac{C_D}{47 \text{ nF}} \times 10 \text{ ms} \quad (1)$$

$$t_{\text{STLH,typ}} = \frac{C_D}{47 \text{ nF}} \times 10 \text{ }\mu\text{s} \quad (2)$$

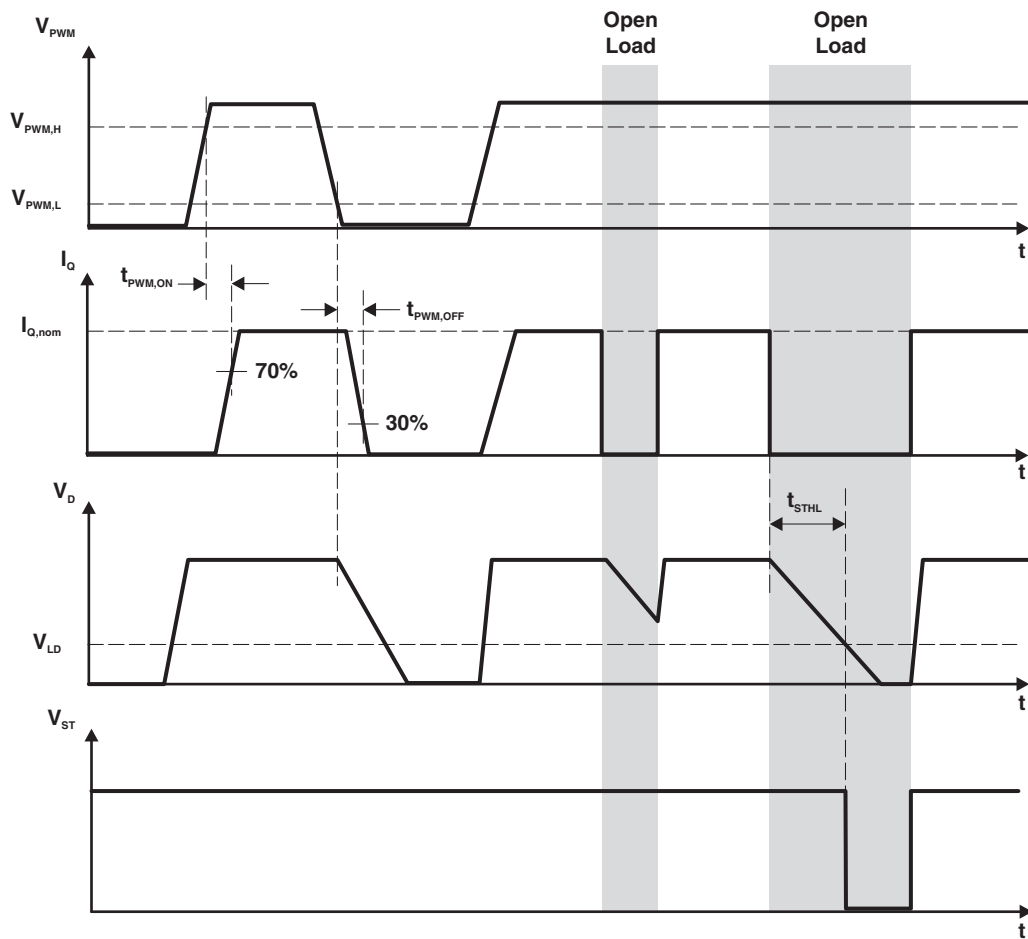

Figure 5. Function and Timing Diagram

7.4 Device Functional Modes

Table 1. Functional Modes

V_{PWM}	DEVICE MODE
High	Active
Low	Sleep

8 Application and Implementation

NOTE

Information in the following applications sections is not part of the TI component specification, and TI does not warrant its accuracy or completeness. TI's customers are responsible for determining suitability of components for their purposes. Customers should validate and test their design implementation to confirm system functionality.

8.1 Application Information

8.1.1 Input Supply Voltage

The input supply voltage calculates as the sum of the LED forward voltages, the TL4242 drop voltage, and the voltage drop across the shunt resistor, R_{REF} . The total LED forward voltage depends on the type of LED and the number of LEDs in the string. The TL4242 drop voltage must be greater than V_{dr} (typically 350 mV), but must not be too high as this could cause excessive power dissipation inside the device. The voltage drop across the shunt resistor is typically 177 mV.

8.1.2 Power Dissipation in TL4242

Power dissipation in the TL4242 will come from two sources:

- Quiescent power: (Input voltage \times Supply current)
- Power dissipation in the pass element:

$$((V_I - V_Q) \times I_Q) \quad (3)$$

The power dissipation in the pass element can be significant if the input voltage, V_I , is much higher than V_Q . The power dissipation is also dependent on the LED current. Equation 4 is an example calculation using the design parameters listed in Table 2.

Table 2. Design Parameters

DESIGN PARAMETER	EXAMPLE VALUE
V_I	13.5 V
V_Q	7 V
I_Q	0.2 A

$$((V_I - V_Q) \times I_Q) = (13.5 - 7) \times 0.2 = 1.3 \text{ W} \quad (4)$$

In Equation 4, there is 1.3 W of power dissipation in the pass element of the TL4242. This power dissipation will cause the junction temperature of the device to increase. The increase in temperature is equal to $R_{\theta JA} \times 1.3 \text{ W}$. Please note that $R_{\theta JA}$ is dependent on the PCB layout.

8.1.3 Setting the Output Current

An external shunt resistor in the ground path of the connected LEDs is used to sense the LED current. A regulation loop holds the voltage drop at the shunt resistor at a constant level of 177 mV (typical). The constant-current level can be adjusted by selecting the shunt resistance, R_{REF} . Calculate the typical output current using the equation:

$$I_{Q,typ} = V_{REF}/R_{REF}$$

where

- V_{REF} is the reference voltage (typically 177 mV) (see [Electrical Characteristics](#)).

The equation applies for $R_{REF} = 0.39 \Omega$ to 10Ω .

The output current is shown as a function of the reference resistance in Figure 1.

8.2 Typical Application

Figure 6 shows a typical application with the TL4242 driving three LEDs in series.

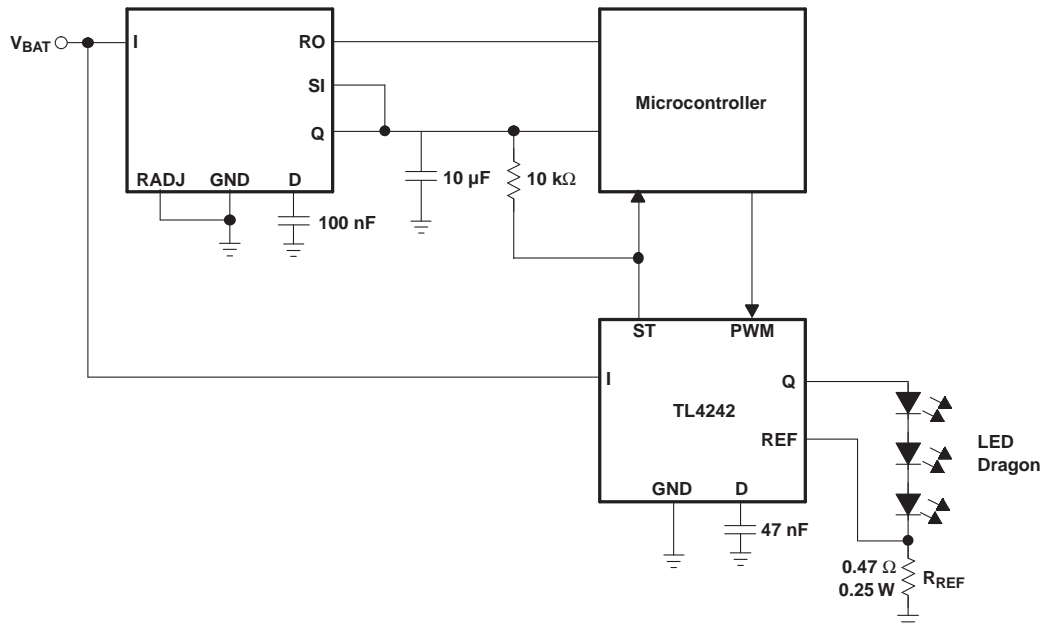

Figure 6. Application Circuit

8.2.1 Design Requirements

For this design example, use the following as the input parameters in Table 3.

Table 3. Design Parameters

DESIGN PARAMETERS	EXAMPLE VALUE
# of LEDs	3
Forward Voltage of each LED	3.5 V
LED Current	377 mA

8.2.2 Detailed Design Procedure

8.2.2.1 Input Voltage

The input voltage must be greater than the sum of the LED forward voltages, the TL4242 drop voltage, and the voltage drop across the shunt resistor, R_{REF} . In this design example, the total LED forward voltage is $3 \times 3.5 \text{ V} = 10.5 \text{ V}$. The typical TL4242 drop voltage is 350 mV. The typical voltage drop across the shunt resistor is 177 mV. In sum, the input voltage must be greater than $10.5 + 0.350 + 0.177 = 11.027 \text{ V}$. An appropriate input voltage for this application would be 12 V.

8.2.2.2 Shunt Resistor

The shunt resistor value, R_{REF} , can be calculated based on the desired LED current.

$$I_{Q,typ} = V_{REF}/R_{REF}$$

where

- V_{REF} is the reference voltage (typically 177 mV) (see [Electrical Characteristics](#)). (6)

As shown in [Design Requirements](#), the desired LED current is 377 mA. The appropriate R_{REF} value for this application calculates to be 0.47 Ω.

8.2.3 Application Curve

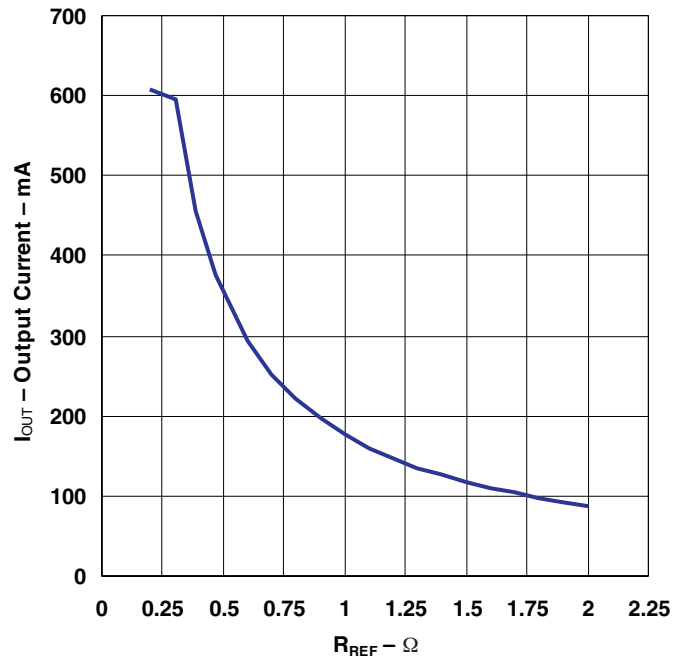

Figure 7. Output Current vs External Resistor

9 Power Supply Recommendations

The input voltage at the I pin must be greater than the sum of the LED forward voltages, the voltage drop across the TL4242 (from I to Q), and the voltage drop across the shunt resistor R_{REF} . For an example of this calculation, refer to [Typical Application](#). The input voltage should not exceed the recommended maximum operation voltage of 42 V.

10 Layout

10.1 Layout Guidelines

The REF pin should be routed directly to the shunt resistor, R_{REF} . If there is a long PCB trace between the LED string and the shunt resistor, the REF pin should connect close to the shunt resistor (rather than close to the LED string) to allow for accurate sensing across the shunt resistor.

The traces for I and Q will carry the full LED current. These traces should be the appropriate width to carry the LED current.

The exposed thermal pad on the bottom of the TL4242 should be connected to the PCB. The thermal pad helps to dissipate heat in the case of high power dissipation in the device. To further enhance the thermal performance of the device, the thermal pad can be connected by vias to the ground layer in the PCB.

10.2 Layout Example

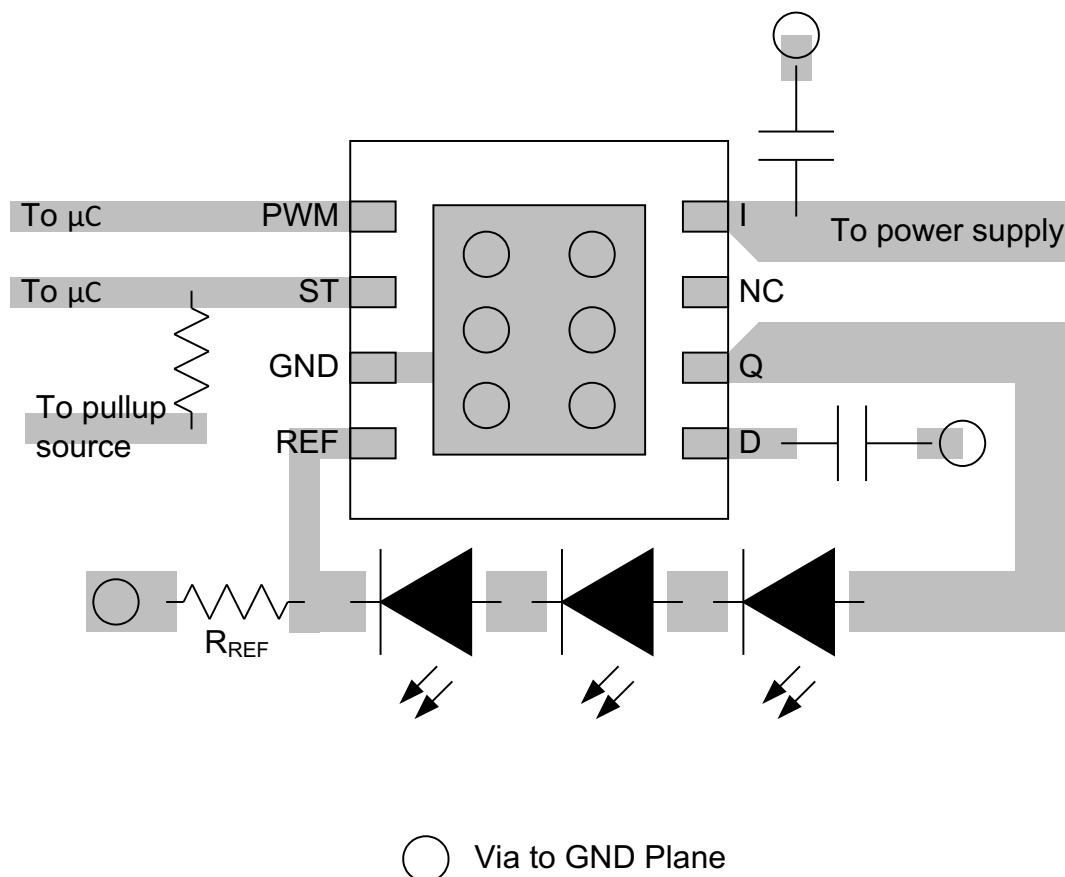

Figure 8. PCB Layout

11 Device and Documentation Support

11.1 Trademarks

All trademarks are the property of their respective owners.

11.2 Electrostatic Discharge Caution



These devices have limited built-in ESD protection. The leads should be shorted together or the device placed in conductive foam during storage or handling to prevent electrostatic damage to the MOS gates.

11.3 Glossary

[SLYZ022](#) — *TI Glossary*.

This glossary lists and explains terms, acronyms, and definitions.

12 Mechanical, Packaging, and Orderable Information

The following pages include mechanical, packaging, and orderable information. This information is the most current data available for the designated devices. This data is subject to change without notice and revision of this document. For browser-based versions of this data sheet, refer to the left-hand navigation.

PACKAGING INFORMATION

Orderable Device	Status (1)	Package Type	Package Drawing	Pins	Package Qty	Eco Plan (2)	Lead finish/ Ball material (6)	MSL Peak Temp (3)	Op Temp (°C)	Device Marking (4/5)	Samples
TL4242DRJR	ACTIVE	SON	DRJ	8	3000	RoHS & Green	NIPDAU	Level-3-260C-168 HR	-40 to 125	T4242	Samples

(1) The marketing status values are defined as follows:

ACTIVE: Product device recommended for new designs.

LIFEBUY: TI has announced that the device will be discontinued, and a lifetime-buy period is in effect.

NRND: Not recommended for new designs. Device is in production to support existing customers, but TI does not recommend using this part in a new design.

PREVIEW: Device has been announced but is not in production. Samples may or may not be available.

OBSOLETE: TI has discontinued the production of the device.

(2) **RoHS:** TI defines "RoHS" to mean semiconductor products that are compliant with the current EU RoHS requirements for all 10 RoHS substances, including the requirement that RoHS substance do not exceed 0.1% by weight in homogeneous materials. Where designed to be soldered at high temperatures, "RoHS" products are suitable for use in specified lead-free processes. TI may reference these types of products as "Pb-Free".

RoHS Exempt: TI defines "RoHS Exempt" to mean products that contain lead but are compliant with EU RoHS pursuant to a specific EU RoHS exemption.

Green: TI defines "Green" to mean the content of Chlorine (Cl) and Bromine (Br) based flame retardants meet JS709B low halogen requirements of <=1000ppm threshold. Antimony trioxide based flame retardants must also meet the <=1000ppm threshold requirement.

(3) MSL, Peak Temp. - The Moisture Sensitivity Level rating according to the JEDEC industry standard classifications, and peak solder temperature.

(4) There may be additional marking, which relates to the logo, the lot trace code information, or the environmental category on the device.

(5) Multiple Device Markings will be inside parentheses. Only one Device Marking contained in parentheses and separated by a "-" will appear on a device. If a line is indented then it is a continuation of the previous line and the two combined represent the entire Device Marking for that device.

(6) Lead finish/Ball material - Orderable Devices may have multiple material finish options. Finish options are separated by a vertical ruled line. Lead finish/Ball material values may wrap to two lines if the finish value exceeds the maximum column width.

Important Information and Disclaimer: The information provided on this page represents TI's knowledge and belief as of the date that it is provided. TI bases its knowledge and belief on information provided by third parties, and makes no representation or warranty as to the accuracy of such information. Efforts are underway to better integrate information from third parties. TI has taken and continues to take reasonable steps to provide representative and accurate information but may not have conducted destructive testing or chemical analysis on incoming materials and chemicals. TI and TI suppliers consider certain information to be proprietary, and thus CAS numbers and other limited information may not be available for release.

In no event shall TI's liability arising out of such information exceed the total purchase price of the TI part(s) at issue in this document sold by TI to Customer on an annual basis.

OTHER QUALIFIED VERSIONS OF TL4242 :

- Automotive: [TL4242-Q1](#)

NOTE: Qualified Version Definitions:

- Automotive - Q100 devices qualified for high-reliability automotive applications targeting zero defects

TAPE AND REEL INFORMATION

QUADRANT ASSIGNMENTS FOR PIN 1 ORIENTATION IN TAPE

*All dimensions are nominal

Device	Package Type	Package Drawing	Pins	SPQ	Reel Diameter (mm)	Reel Width W1 (mm)	A0 (mm)	B0 (mm)	K0 (mm)	P1 (mm)	W (mm)	Pin1 Quadrant
TL4242DRJR	SON	DRJ	8	3000	330.0	12.4	4.25	4.25	1.15	8.0	12.0	Q2

TAPE AND REEL BOX DIMENSIONS

*All dimensions are nominal

Device	Package Type	Package Drawing	Pins	SPQ	Length (mm)	Width (mm)	Height (mm)
TL4242DRJR	SON	DRJ	8	3000	356.0	356.0	35.0

DRJ (S-PWSON-N8)

PLASTIC SMALL OUTLINE NO-LEAD

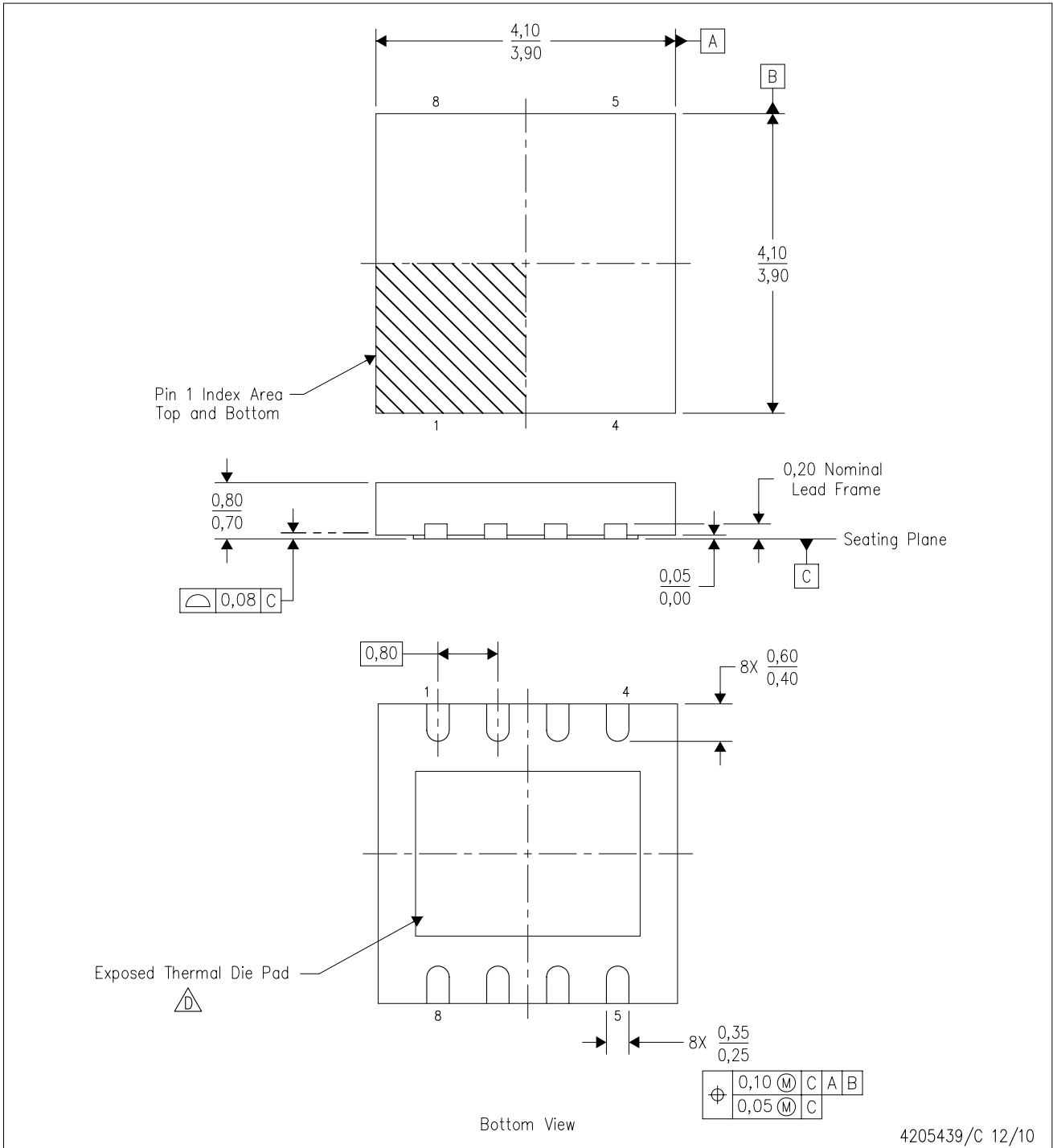

4205439/C 12/10

- NOTES:
- A. All linear dimensions are in millimeters. Dimensioning and tolerancing per ASME Y14.5M-1994.
 - B. This drawing is subject to change without notice.
 - C. SON (Small Outline No-Lead) package configuration.
 - The package thermal pad must be soldered to the board for thermal and mechanical performance. See the Product Data Sheet for details regarding the exposed thermal pad dimensions.
 - E. Package complies to JEDEC MO-229 variation WGGB.

THERMAL PAD MECHANICAL DATA

DRJ (S-PWSON-N8)

PLASTIC SMALL OUTLINE NO-LEAD

THERMAL INFORMATION

This package incorporates an exposed thermal pad that is designed to be attached directly to an external heatsink. The thermal pad must be soldered directly to the printed circuit board (PCB). After soldering, the PCB can be used as a heatsink. In addition, through the use of thermal vias, the thermal pad can be attached directly to the appropriate copper plane shown in the electrical schematic for the device, or alternatively, can be attached to a special heatsink structure designed into the PCB. This design optimizes the heat transfer from the integrated circuit (IC).

For information on the Quad Flatpack No-Lead (QFN) package and its advantages, refer to Application Report, QFN/SON PCB Attachment, Texas Instruments Literature No. SLUA271. This document is available at www.ti.com.

The exposed thermal pad dimensions for this package are shown in the following illustration.

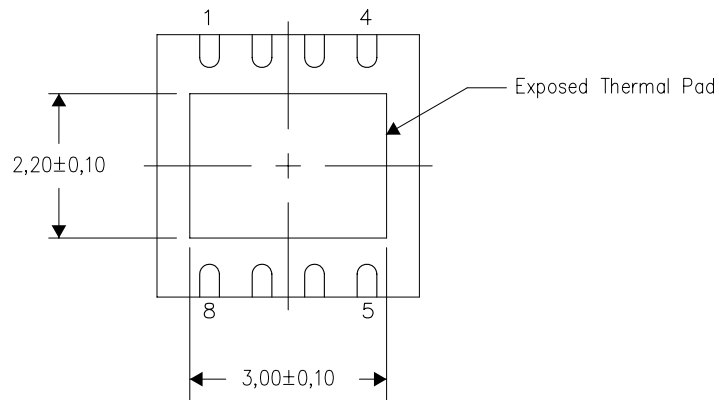

Bottom View

Exposed Thermal Pad Dimensions

4206882/F 01/11

NOTE: All linear dimensions are in millimeters

DRJ (S-PWSON-N8)

SMALL PACKAGE OUTLINE NO-LEAD

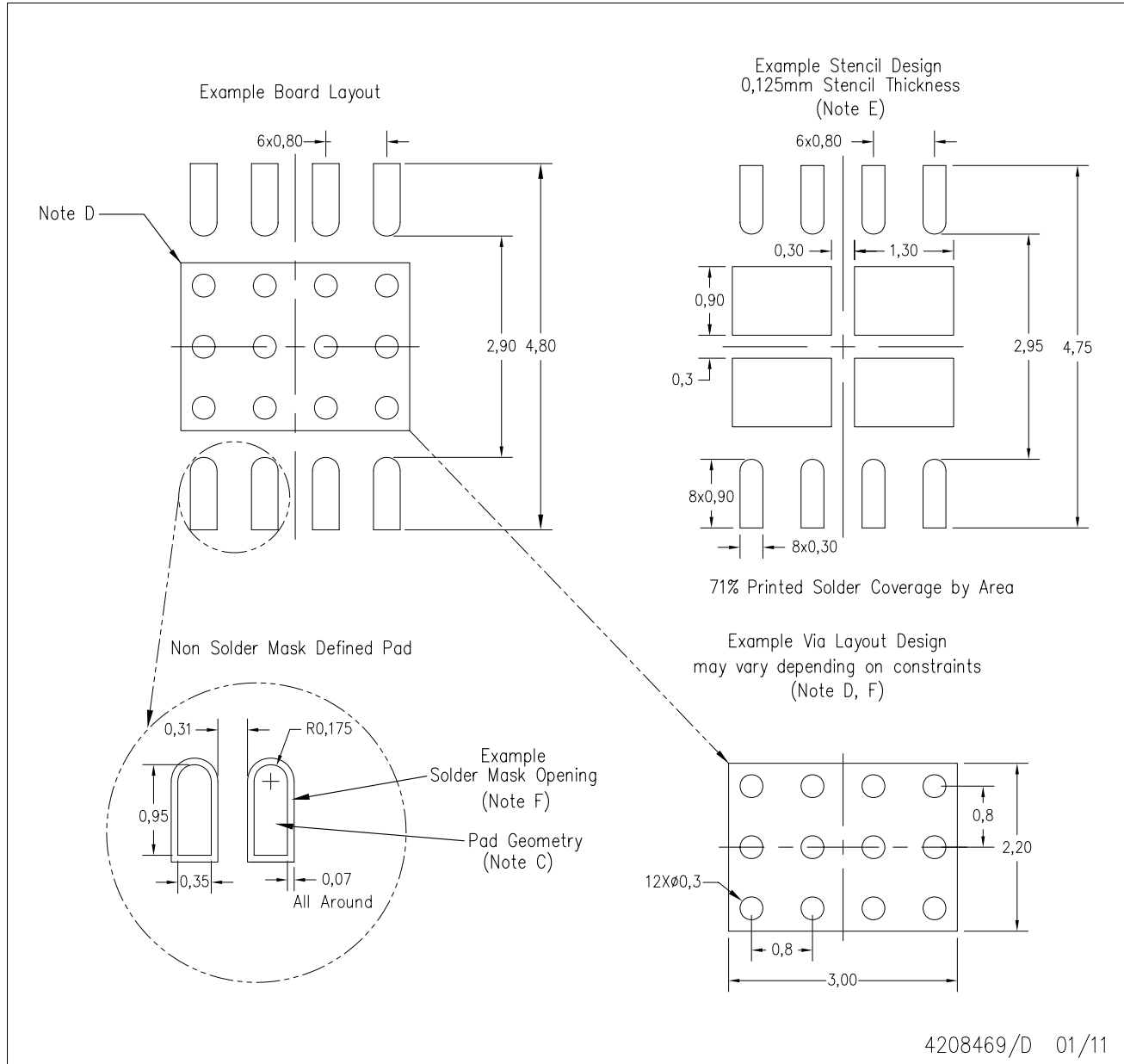

- NOTES:
- A. All linear dimensions are in millimeters.
 - B. This drawing is subject to change without notice.
 - C. Publication IPC-7351 is recommended for alternate designs.
 - D. This package is designed to be soldered to a thermal pad on the board. Refer to Application Note, Quad Flat-Pack Packages, Texas Instruments Literature No. SLUA271, and also the Product Data Sheets for specific thermal information, via requirements, and recommended board layout. These documents are available at www.ti.com <<http://www.ti.com>>.
 - E. Laser cutting apertures with electropolish and also rounding corners will offer better paste release. Customers should contact their board assembly site for stencil design recommendations. Refer to IPC 7525 for stencil design considerations.
 - F. Customers should contact their board fabrication site for solder mask tolerances and vias tenting recommendations for vias placed in the thermal pad.

IMPORTANT NOTICE AND DISCLAIMER

TI PROVIDES TECHNICAL AND RELIABILITY DATA (INCLUDING DATA SHEETS), DESIGN RESOURCES (INCLUDING REFERENCE DESIGNS), APPLICATION OR OTHER DESIGN ADVICE, WEB TOOLS, SAFETY INFORMATION, AND OTHER RESOURCES "AS IS" AND WITH ALL FAULTS, AND DISCLAIMS ALL WARRANTIES, EXPRESS AND IMPLIED, INCLUDING WITHOUT LIMITATION ANY IMPLIED WARRANTIES OF MERCHANTABILITY, FITNESS FOR A PARTICULAR PURPOSE OR NON-INFRINGEMENT OF THIRD PARTY INTELLECTUAL PROPERTY RIGHTS.

These resources are intended for skilled developers designing with TI products. You are solely responsible for (1) selecting the appropriate TI products for your application, (2) designing, validating and testing your application, and (3) ensuring your application meets applicable standards, and any other safety, security, regulatory or other requirements.

These resources are subject to change without notice. TI grants you permission to use these resources only for development of an application that uses the TI products described in the resource. Other reproduction and display of these resources is prohibited. No license is granted to any other TI intellectual property right or to any third party intellectual property right. TI disclaims responsibility for, and you will fully indemnify TI and its representatives against, any claims, damages, costs, losses, and liabilities arising out of your use of these resources.

TI's products are provided subject to [TI's Terms of Sale](#) or other applicable terms available either on ti.com or provided in conjunction with such TI products. TI's provision of these resources does not expand or otherwise alter TI's applicable warranties or warranty disclaimers for TI products.

TI objects to and rejects any additional or different terms you may have proposed.

Mailing Address: Texas Instruments, Post Office Box 655303, Dallas, Texas 75265
Copyright © 2022, Texas Instruments Incorporated

Looking for pricing, stock, or lifecycle information?

Click below to explore more details on WIN SOURCE:

 [View TL4242DRJR-P on WIN SOURCE](#)

 [Texas Instruments](#) Information

Optimize Your Supply Chain with WIN SOURCE Solutions

-  Global Sourcing Solution
-  Obsolete Management
-  Cost Control Management
-  Shortage Management
-  Alternative Solution
-  Excess Inventory Management