



**THE DATASHEET OF
CPC5604A**



Features

- 56K Compatible
- Transformerless Optical Design
- Complete Ring Detector Circuit
- Caller ID Signal Detection
- Snoop Circuitry
- Integrated Hybrid
- Small 32-Pin Plastic Package
- PCMCIA Compatible
- PCB Space and Cost Savings
- compatible with all modem speeds including V.90
- FCC compliant
- Compatible with U.S. and International dial up Phone lines
- CTR-21 Compliant

Applications

- 56K Modems/Fax including PCMCIA
- Computer Telephony
- Voice Mail Systems
- Security/alarm systems
- Utility Meters
- Vending machines
- Voice Over IP
- Network routers
- PBX systems
- Home Medical Devices
- Plant monitoring equipment
- PC Mother Boards
- Set Top Boxes (Cable TV Modems)

Description

The CPC5604 is a single package optical Data Access Arrangement (DAA) device in a low profile surface mount PCMCIA compatible package. With a few external components, the CPC5604 provides a full featured International 56K capable solution. This device is well suited for all 56K modems, voice mail systems, fax machines, computer telephony applications, remote data access, medical, and security systems. For International compliance, external passive component values can be changed or, the CPC5604 can be used in conjunction with the CPC5601 Programmable Driver for a host programmable International DAA.

Approvals

- UL1950/UL1459
- EN60950

Ordering Information

Part #	Description
CPC5604A	Data Access Arrangement, Tape and Reel
CPC5604ATR	Data Access Arrangement, Tape and Reel

Block Diagram

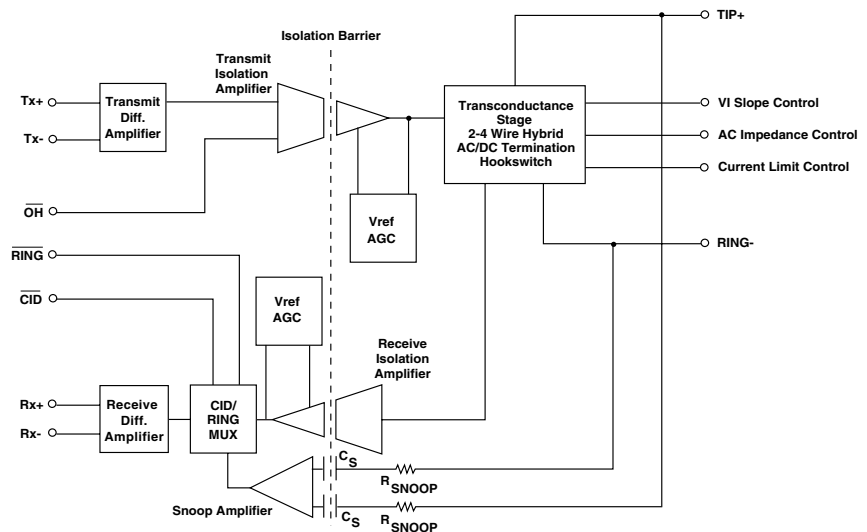



Table of Contents

Table 1 - Performance Specifications3

Table 1 - Performance Specifications (Continued)4

Table 2 - Package Pinout5

Applications6

 North American Reference Design Schematic6

Table 3 - North American Reference Design Bill of Materials.....7

International Reference Design Schematic.....8

Table 4 - International Reference Design Bill of Materials9

CTR-21 Reference Design Schematic10

Table 5 - Reference Design Schematic Bill of Materials11

CTR-21 with Exceptions Reference Design Schematic12

Table 6 - CTR-21 with Exceptions Reference Design Bill of Materials13

Introduction14

 Ring Detection via Snoop Circuit.....14

 Caller ID (CID) Detection via Snoop Circuit14

 Hook Switch Control14

 Transmit Signal14

Receive Signal Path15

Transmit Signal Path15

Ring Signal Detection16

Figure 3 - Caller ID Protocol17

DC Characteristics.....17

Figure 4 - Outlook DC Resistance Tip/Ring Setup18

On-Hook Resistance18

Current Limiting18

CTR-21 Compliance18

AC Characteristics.....18

Differential and Single Ended Mode19

Receive and Transmit Frequency Response19

Figure 4C - Transmit Frequency Response Setup20

Figure 4D - Transmit Frequency Response Tx±.....20

Distortion21

Figure 5C - Transmit Distortion Text Tx± to Tip/Ring Setup22

Figure 5D - Transmit Distortion on Tip/Ring22

Trans-Hybrid Loss23

Table of Contents (Continued)

Return Loss	24
Snoop Mode Frequency Response.....	25
Snoop Mode Distortion	26
Snoop Mode Common Mode Rejection Ratio (CMRR)	27
Country Specific Component Values.....	28
Interconnection to Rockwell 56K Chipset	29
Interconnection to Lucent 56K Chipset	30
Mechanical Dimensions.....	31

Absolute Maximum Ratings are stress ratings. Stresses in excess of these ratings can cause permanent damage to the device. Functional operation of the device at these or any other conditions beyond those indicated in the operational sections of this data sheet is not implied. Exposure of the device to the absolute maximum ratings for an extended period may degrade the device and effect its reliability.

Electrical Characteristics

PARAMETER	MIN	TYP	MAX	UNIT	CONDITION
DC Characteristics					
Operating Voltage V_{CC}	4.75	5	5.25	V	Modem Side
Operating Current I_{CC}	-	-	15	mA	Modem Side
Operating Voltage V_{DD}	3.5	-	5.25	V	From Tip and Ring
Operating Current I_{DD}	-	-	5	mA	Drawn from Tip and Ring
On-Hook Characteristics					
DC Resistance (metallic)	10	-	-	M Ω	Tip to Ring, 100VDC Applied
DC Resistance (longitudinal)	10	-	-	M Ω	150VDC Applied from Tip and Ring to Earth GND
Ring Signal Detection at 68 Hz*	5	-	-	V	Ring Signal Applied to Tip and Ring
Ring Signal Detection at 15 Hz*	28	-	-	V	Ring Signal Applied to Tip and Ring
Snoop Circuit Frequency Response*	600	-	4000	Hz	3dB Corner Frequency
Snoop Circuit CMRR	-	-40	-	dB	120V _{RMS} 60Hz Common Mode Signal on Tip/Ring
Ringer Equivalence	-	0.1B	-	REN	-
Longitudinal Balance	60	-	-	dB	Per FCC Part 68.3
Off-Hook Characteristics					
AC Impedance*	-	600	-	Ω	Tip to Ring
Longitudinal Balance 68.3	40	-	-	dB	Tip and Ring to Ground, per FCC part
Return Loss	-	26	-	dB	Against 600 Ω , 1800Hz

Table 1 -Performance Specifications (continued)

PARAMETER	MIN	TYP	MAX	UNIT	CONDITION
Transmit/Receive Characteristics					
Frequency Response*	30	-	4000	Hz	3dB corner frequency
Trans-Hybrid Loss*	-	30	-	dB	Against 600Ω resistive, 1800Hz
Transmit Insertion Loss*	-1	0	1	dB	-
Receive Insertion Loss*	-1	0	1	dB	-
Average In-band Noise	-	-100	-	dB	4kHz Flat bandwidth
Harmonic Distortion	-	-	-80	dB	-3dBm, 600Hz, 2nd Harmonic
Transmit Level*	-	-	0	dBm	Single Tone Sine Wave
Receive Level*	-	-	0	dBm	Single Tone Sine Wave
Rx+/Rx- Output Drive Current	-	-	0.5	mA	Sink and Source
Tx+/Tx- Input Impedance	60	90	120	kΩ	-
Isolation Characteristics					
Isolation Surge Voltage	1500	-	-	V _{SURGE}	Line Side to Modem Side
Surge Rise Time	2000	-	-	V/μs	No Damage via T/R
Control Logic (OH, CID, RING)					
Input Threshold Voltage	0.8	-	2.0	V	
High Level Input Current	-	-	-20	μA	
Low Level Input Current	-100	-	-	μA	
Output High Voltage	V _{CC} -0.4	-	-	V	1MΩ to Ground
Output Low Voltage	-	-	0.4	V	1MΩ to VCC
Isolation Voltage	—	-	1500	V _{RMS}	
Tip/Ring Current (continuous)	10	-	120	mA	
Total Package Dissipation	—	-	1	W	
Operational Temperature	-20	-	+85	°C	
Storage Temperature	-40	-	+125	°C	
Soldering Temperature (10 seconds Max)	—	-	+220	°C	

Unless Otherwise Noted all Specifications @ 25oC.

* Refer to Typical Application Circuit.

Table 2 -Package Pinout

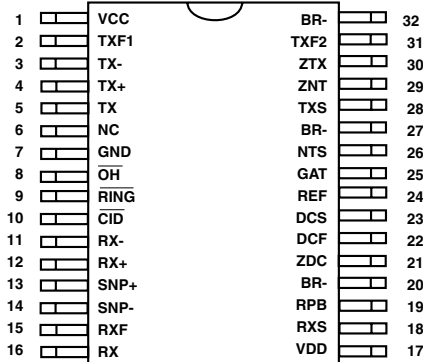

Pin #	Name	Function
1	V _{CC}	Host power supply, +5 Volts +/-5%.
2	TXF1	TX isolation amplifier output.
3	TX -	NEG differential transmit signal into DAA.
4	TX+	POS differential transmit signal into DAA.
5	TX	TX differential amplifier input.
6	NC	Not Connected.
7	GND	Connect to host analog ground.
8	OH	Driving this signal low asserts the off-hook condition.
9	RING	Active low indicates an incoming half waved ring signal pulsed High to Low at the ring frequency-typically 20Hz.
10	CID	Driving this signal low places the Caller ID information on the RX pins when the DAA is on hook (OH is deasserted).
11	RX-	NEG differential analog receive signal from the telephone line and must be AC coupled with a 0.1 uF capacitor.
12	RX+	POS differential analog receive signal from the telephone line and must be AC coupled with a 0.1 uF capacitor.
13	SNP+	One of two differential snoop inputs.
14	SNP-	One of two differential snoop inputs.
15	RXF	Receive photodiode amplifier output.
16	RX	Receive photoamplifier summing junction.
17	V _{DD}	Power supply for line side portion of CPC5604.
18	RXS	Receive photodiode servo input.
19	RPB	Sets receive LED prebias current.
20	BR-	Return to bridge rectifier negative output.
21	ZDC	Sets electronic inductor DCR/Current Limit.
22	DCF	DC Filter Point.
23	DCS	VI slope control via external resistor.
24	REF	1.25V internal voltage reference.
25	GAT	Depletion MOSFET gate control.
26	NTS	Receive signal input path via Tip and Ring.
27	BR-	Return to bridge rectifier negative output.
28	TXS	Receive photodiode amplifier input.
29	ZNT	Sets DAA impedance via external passive network.
30	ZTX	Transmit Transconductance gain setting pin.
31	TXF2	Receive photodiode amplifier output.
32	BR-	Return to bridge rectifier negative output.

Applications

North American Reference Design Schematic

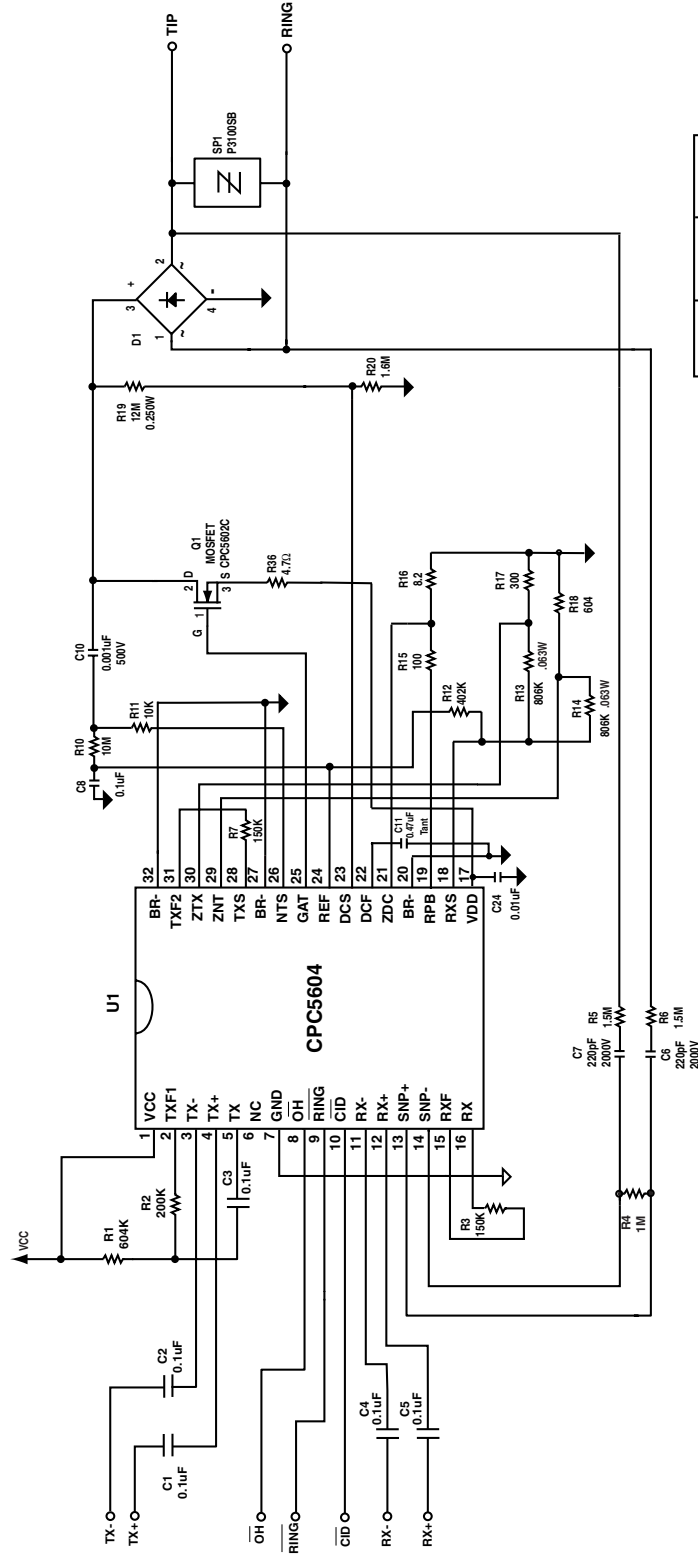

Drawn:	JC/IMG	Date:	10/27/99	Rev:	B
Company:	CP Clare Corp.				
Title:	U.S. Reference Design				

ALL RESISTORS ARE 100W UNLESS OTHERWISE NOTED

Table 3 - North American Reference Design Bill of Materials

QTY.	Designation	Description	Manufacturer	Package Type
1	U1	CPC5604A	Clare	32 Lead SOIC
1	Q1	CPC5602C	Clare	SOT-223
1	R1	604k 1% Res.	Meritek	'0603
1	R18	604 ohm 1% Res.	Meritek	'0603
1	R2	200k 5% Res.	Meritek	'0603
1	R4	1M 5% Res	Meritek	0603
2	R3, R7	150k 5% Res.	Meritek	'0603
2	R5, R6	1.5M 5% Res.	Meritek	'1206
1	R11	10 K 5% Res.	Meritek	'0603
1	R12	402k 1% Res.	Meritek	'0603
1	R15	100 ohm 5% Res.	Meritek	'0603
2	R13, R14	806K 1% Res. 0.063W	Meritek	'0603
1	R16	8.2 5% Res. 1/8W	Meritek	'0603
1	R17	300 ohm 5% Res.	Meritek	'0603
1	R10	10M 5% Res.	Meritek	'0603
1	R19	12M 5% Res. 0.25W	Meritek	'1206
1	R20	1.6M 5% Res.	Meritek	'0805
1	R36	4.7 ohm 5% Res 1/8W	Meritek	'0603
5	C1, C2, C3, C4, C5	0.1 uf 50V 10% X7R	Tecate	'0805
2	C6, C7	220 pf 2000V NPO 5%	Tecate	1808
1	C8	0.1uf 50V 10% X7R	Tecate	'0805
1	C10	0.001uf 500V10% X7R	Tecate	1206
1	C11	0.47uf 25V Tant 10%	Panasonic	SMD
1	C24	.010 uf 50V 10% X7R	Tecate	0805
1	D1	Bridge Rectifier	Shindengen	N/A
1	SP1	Surge Protection	Teccor	D0-214AA
32	TOTAL			

International Reference Design Schematic

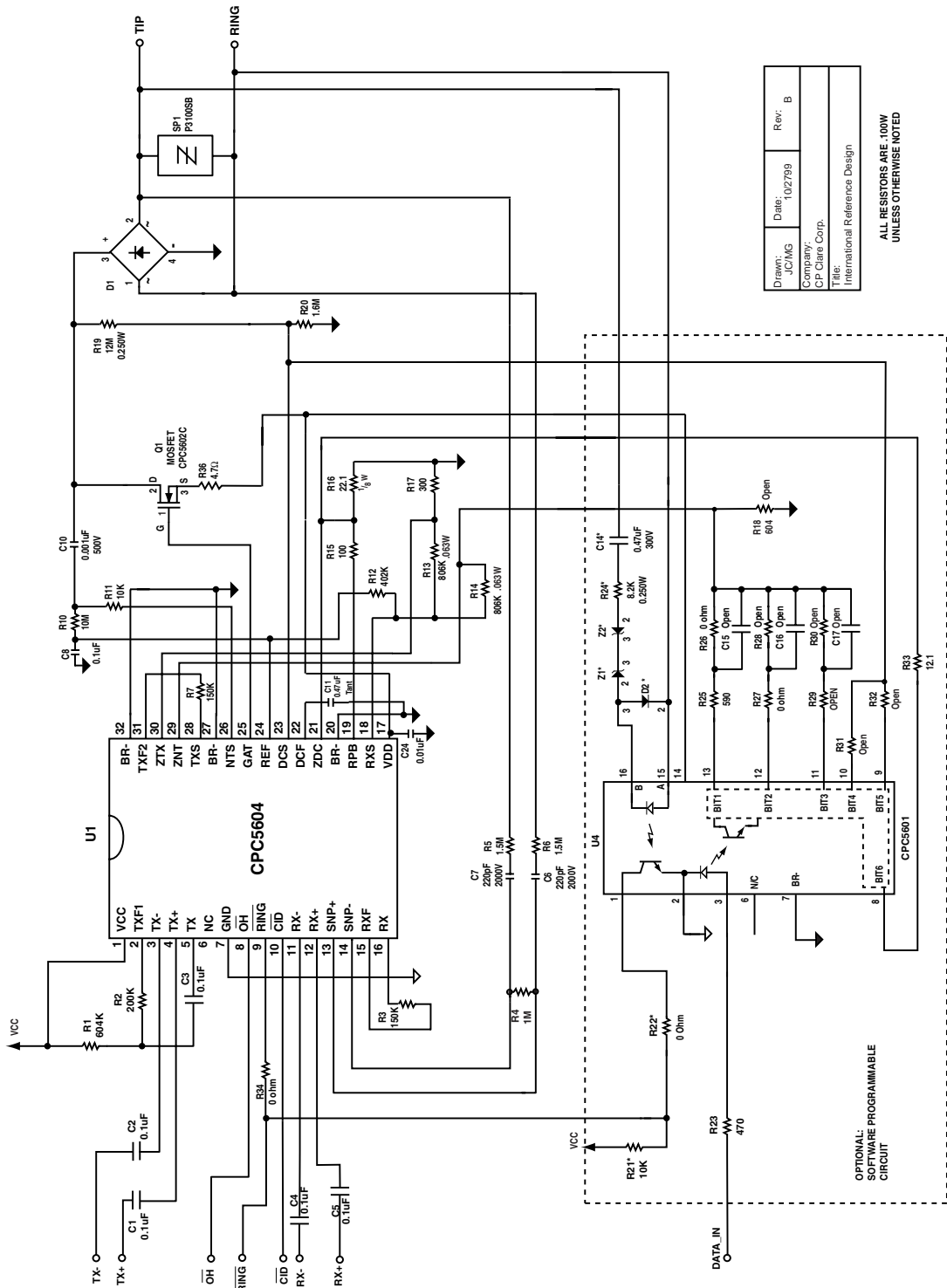
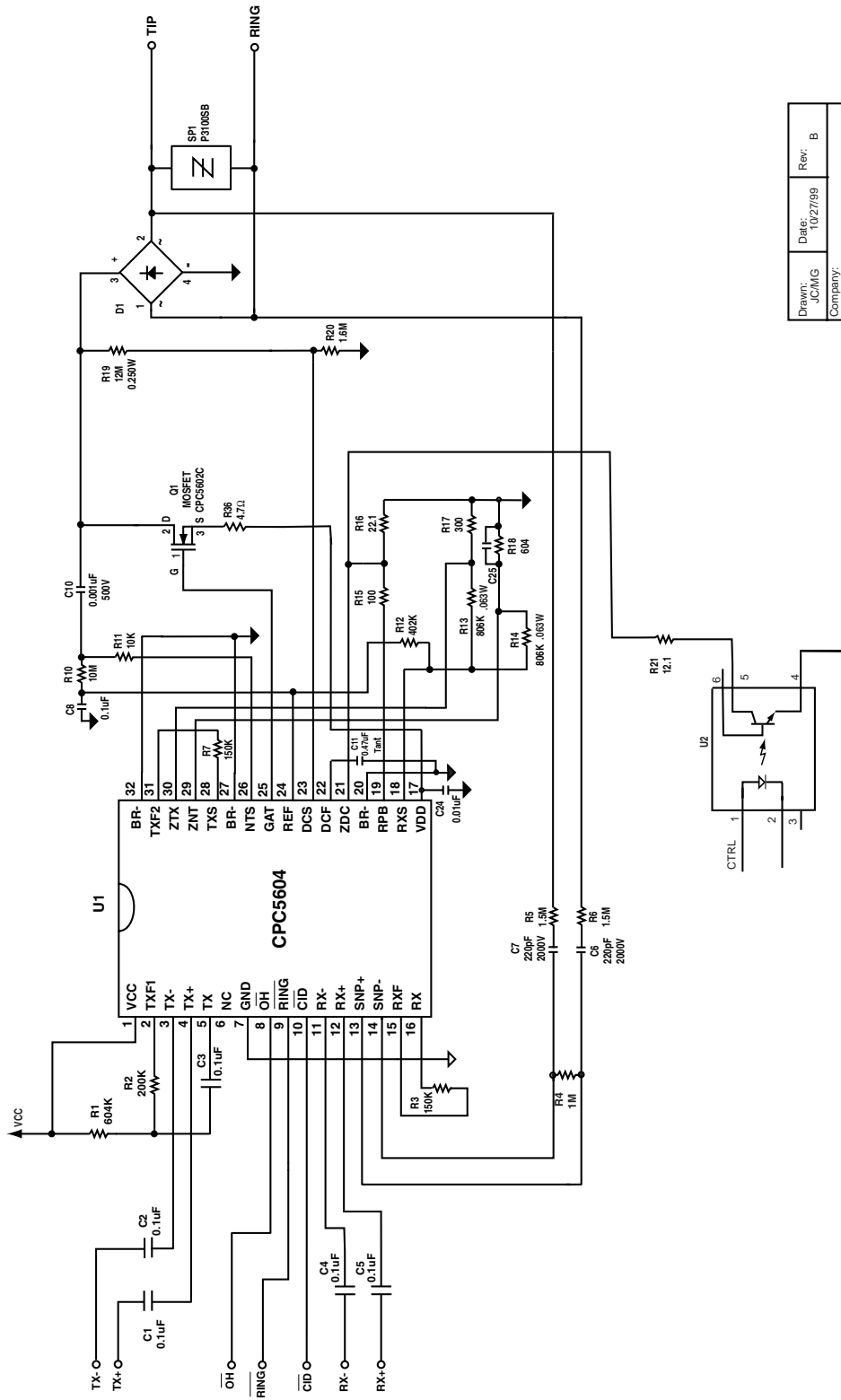

Table 4 - International Reference Design Bill of Materials

QTY.	Designation	Description	Manufacturer	Package Type
1	U1	CPC5604A	Clare	32 Lead SOIC
1	U4	GPC5601D	Clare	SO16
1	Q1	CPC5602C	Clare	SOT-223
1	R1	604k 1% Res.	Meritek	'0603
1	R18	604 ohm 1% Res.	Meritek	'0603
1	R2	200k 5% Res.	Meritek	'0603
1	R4	1M 5% Res.	Meritek	0603
2	R3, R7	150k 5% Res.	Meritek	'0603
2	R5, R6	1.5M 5% Res.	Meritek	'1206
2	R11, R21	10 K 5% Res.	Meritek	'0603
1	R12	402k 1% Res.	Meritek	'0603
1	R15	100 ohm 5% Res.	Meritek	'0603
2	R13, R14	806K 1% Res. 0.063W	Meritek	'0603
1	R16	22.1 1% Res. 1/8W	Meritek	'0603
1	R17	300 ohm 5% Res.	Meritek	'0603
1	R10	10M 5% Res.	Meritek	'0603
1	R19	12M 5% Res. 0.25W	Meritek	'1206
1	R20	1.6M 5% Res.	Meritek	'0805
1	R23	470 ohm 5% Res.	Meritek	'0603
1	R24	8.2k 5% Res. 0.25W	Meritek	'0603
5	R22, R29, R30, R31, R32	Open	-	'0603
1	R25	590 ohm 5% Res.	Meritek	'0603
1	R26	0 ohm Res.	Meritek	'0603
1	R27	0 ohm Res.	Meritek	'0603
1	R28	Open	-	'0603
1	R33	12.1 ohm 1% Res.	Meritek	'0603
1	R34	0 ohm 5% Res.	Meritek	'0603
1	R36	4.7 ohm 5% Res 1/8W	Meritek	'0603
5	C1, C2, C3, C4, C5	0.1 uf 50V 10% X7R	Tecate	'0805
2	C6, C7	220 pf 2000V NPO 5%	Tecate	1808
1	C8	0.1uf 50V 10% X7R	Tecate	'0805
1	C10	0.001uf 500V10% X7R	Tecate	1206
1	C11	0.47uf 25V Tant 10%	Panasonic	SMD
1	C14	.47uf 300V	Tecate	1812
1	C15	Open	-	'0805
1	C16	0.0047uf 50V 10% X7R	Tecate	'0805
1	C17	Open for future use	-	'0805
1	C24	0.01uf 50V 10% X7R	Tecate	0805
1	SP1	Surge Protection	Teccor	D0-214AA
2	Z1, Z2	Zener 20V	Rohm	SOT-23
1	D1	Bridge Rectifier	Shindengen	N/A
1	D2	Diode BAS16	Rohm	SOT-23
53	TOTAL			

CTR-21 Reference Design Schematic



ALL RESISTORS ARE 100W
UNLESS OTHERWISE NOTED

Table 5 - CTR-21 Reference Design Bill of Materials

QTY.	Designation	Description	Manufacturer	Package Type
1	U1	CPC5604A	Clare	32 Lead SOIC
1	Q1	CPC5602C	Clare	SOT-223
1	R1	604k 1% Res.	Meritek	'0603
1	R4	1M 5% Res.	Meritek	0603
1	R18	604 ohms 1% Res.	Meritek	'0603
1	R2	200k 5% Res.	Meritek	'0603
2	R3, R7	150k 5% Res.	Meritek	'0603
2	R5, R6	1.5M 5% Res.	Meritek	'1206
1	R11	10 K 5% Res.	Meritek	'0603
1	R12	402k 1% Res.	Meritek	'0603
1	R15	100 ohm 5% Res.	Meritek	'0603
2	R13, R14	806K 1% Res. 0.063W	Meritek	'0603
1	R16	22.1 5% Res. 1/8W	Meritek	'0603
1	R17	300 ohm 5% Res.	Meritek	'0603
1	R10	10M 5% Res.	Meritek	'0603
1	R19	12M 5% Res. .25W	Meritek	'1206
1	R20	1.6M 5% Res.	Meritek	'0805
1	R21	12.1 5% Res. 0.063W	Meritek	'0603
1	R36	4.7 ohm 5% Res 1/8 W	Meritek	'0603
5	C1, C2, C3, C4, C5	0.1 uf 50V 10% X7R	Tecate	'0805
2	C6, C7	220 pf 2000V NPO 5%	Tecate	1808
1	C8	0.1uf 50V 10% X7R	Tecate	'0805
1	C10	0.001uf 500V10% X7R	Tecate	1206
1	C11	0.47uf 25V Tant 10%	Panasonic	SMD
1	C24	0.01uf 50V 10% X7R	Tecate	'0805
1	D1	Bridge Rectifier	Shindengen	N/A
1	SP1	Surge Protection	Teccor	D0-214AA
1	U2	4N35		
34	TOTAL			

CTR-21 with Exceptions Reference Design Schematic

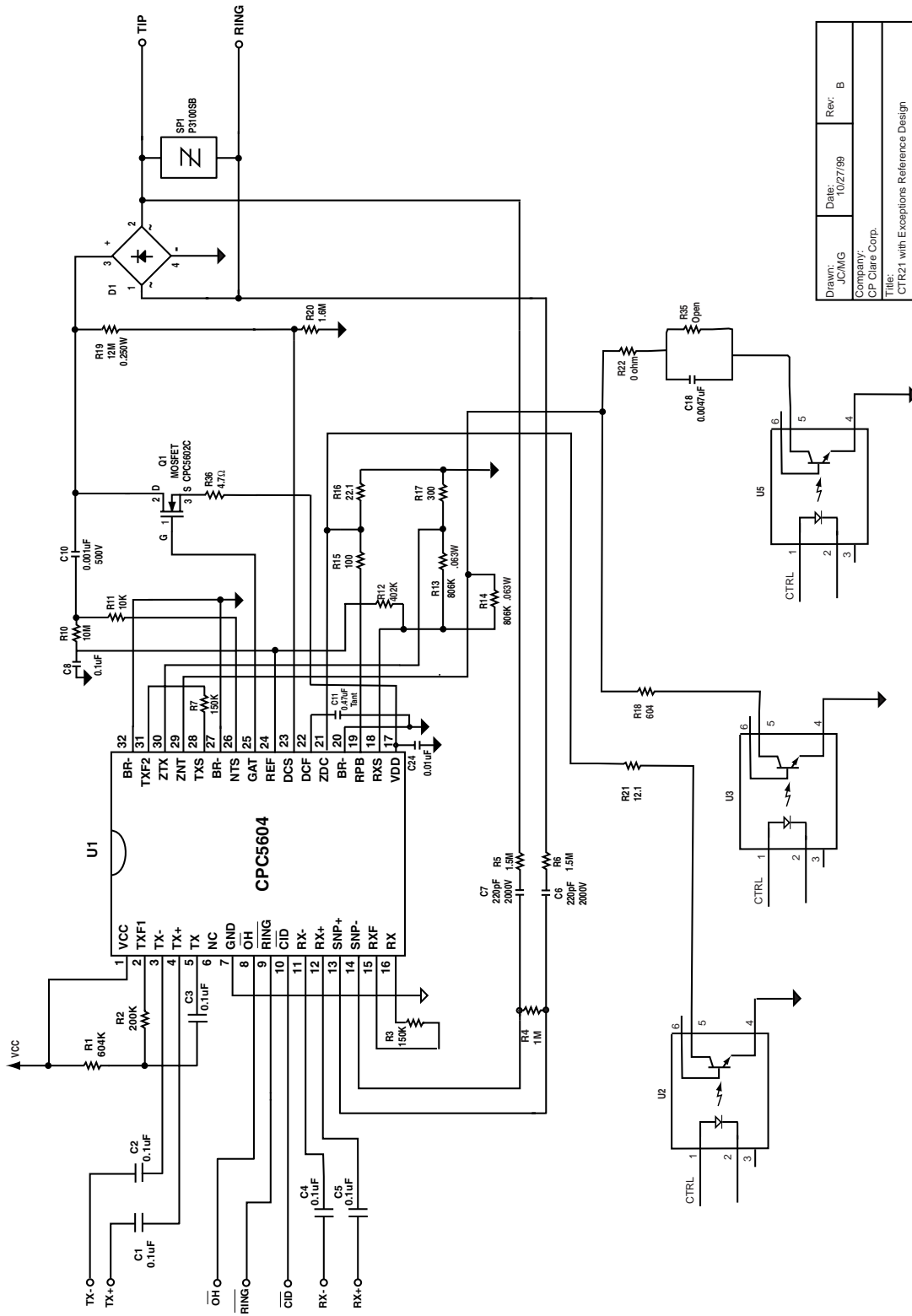

Table 6 - CTR-21 with Exceptions Reference Design Bill of Materials

QTY.	Designation	Description	Manufacturer	Package Type
1	U1	CPC5604A	Clare	32 Lead SOIC
1	Q1	CPC5602C	Clare	SOT-223
1	R1	604k 1% Res.	Meritek	'0603
1	R18	604 ohm 1% Res.	Meritek	'0603
1	R2	200k 5% Res.	Meritek	'0603
1	R4	1M 5% Res	Meritek	0603
2	R3, R7	150k 5% Res.	Meritek	'0603
2	R5, R6	1.5M 5% Res.	Meritek	'1206
1	R11	10 K 5% Res.	Meritek	'0603
1	R12	402k 1% Res.	Meritek	'0603
1	R15	100 ohm 5% Res.	Meritek	'0603
2	R13, R14	806K 1% Res. 0.063W	Meritek	'0603
1	R16	22.1 1% Res. 1/8W	Meritek	'0603
1	R17	300 ohm 5% Res.	Meritek	'0603
1	R10	10M 5% Res.	Meritek	'0603
1	R19	12M 5% Res. 0.25W	Meritek	'1206
1	R20	1.6M 5% Res.	Meritek	'0805
1	R21	12.1 1% Res. 0.063W	Meritek	'0603
1	R22	0 ohm	Meritek	'0603
1	R35	Open	-	'0603
1	R36	4.7 ohm 5% Res 1/8 W	Meritek	'0603
5	C1, C2, C3, C4, C5	0.1 uf 50V 10% X7R	Tecate	'0805
2	C6, C7	220 pf 2000V NPO 5%	Tecate	1808
1	C8	0.1uf 50V 10% X7R	Tecate	'0805
1	C10	0.001uf 500V10% X7R	Tecate	1206
1	C11	0.47uf 25V Tant 10%	Panasonic	SMD
1	C24	0.01uf 50V 10% X7R	Tecate	0805
1	D1	Bridge Rectifier	Shindengen	N/A
1	SP1	Surge Protection	Teccor	D0-214AA
1	U2	4N35		
1	U3	4N35		
1	U5	4N35		
38	TOTAL			

Introduction

The LITELINK™ (CPC5604) is a single package International Data Access Arrangement solution that is designed to be used in a variety of telephone applications including high performance 56kbps (V.90) modems. The LITELINK™ uses advanced optical signal coupling techniques to provide the required electrical isolation between the telephone and the Customer Premises Equipment (CPE). The LITELINK™ differs from other solutions using optical or capacitive isolation techniques by including the barrier inside the IC package, thus eliminating the need for external optocouplers or high-voltage capacitors in the data path resulting in overall reduced board space. The LITELINK™ has been designed to meet or exceed the requirements of international regulatory agencies.

For international PTT compliance external passive components can be changed to meet different country requirements.

For added flexibility, a second device, the CPC5601, can be used in conjunction with the CPC5604 to offer a host programmable solution. The CPC5601 is programmed serially through the host's microcontroller. Using the CPC5601 along with the CPC5604 eliminates the need to change external passive components allowing for a flexible, fully international DAA.

Ring Detection via Snoop Circuit

While in the on-hook state ($\overline{\text{OH}}$ deasserted), an internal multiplexer turns on a "snoop" circuit that actively monitors the phone line for two conditions: incoming ring signal and Caller ID (CID) information. The snoop circuit "snoops" the line continuously while drawing a low 2uA max. current from the telephone line thus meeting regulatory requirements. When the central office (CO) places a ring signal on the telephone line, $90V_{\text{RMS}}$ max, the RING output is pulsed from High to Low for 2 seconds at the same frequency as the AC signal, typically 20Hz, and restored to High during the 4 second delay. The ring detection circuitry is designed to reject false signaling from pulse dialing circuits or noise on the line.

Caller ID (CID) Detection via Snoop Circuit

CID is a service offered by the telephone company to provide caller information (i.e. the caller's telephone number) to the called party. The CID signal is present on the telephone line after the first ring burst is sent from the CO. After this first ring burst is detected by the host,

the host asserts the $\overline{\text{CID}}$ line which automatically couples the snoop circuit to the RX outputs on the LITELINK™. After the $\overline{\text{CID}}$ signal is processed by the host, the host will deactivate the CID signal. At this point the host can answer the call by asserting the OH signal. Note that when the LITELINK™ goes off-hook it automatically disconnects the snoop path from both RX and RING outputs. Signals appearing on the telephone line are now coupled through the optical isolation barrier in the LITELINK™ and not via the snoop path.

Hook Switch Control

The OH or off-hook input is used to place the DAA on or off-hook. When the input is High, the DAA is on-hook or ready to receive calls from the CO. In this mode the snoop circuitry is enabled as described above. Driving OH Low places the DAA off-hook allowing the CO supplied loop current to flow (120mA max.), indicating the DAA is answering or preparing to place a call.

Transmit Signal

Outgoing analog signals to be transmitted to the telephone lines are placed differentially on the TX+ and TX- inputs of the CPC5604. Transmit level from the user device is limited to 0dBm or 2.1Vp-p. The differential transmit signal is converted to a single ended signal by the CPC5604. The transmit signal is transferred across an optical barrier by an electrical-optical-electrical amplifier, which is transparent to the user. Variations in gain due to electrical-optical-electrical efficiency are virtually eliminated by an on-chip automatic gain control circuit which sets the input to output gain of the photodiode amplifier to 1. This results in a TX insertion loss of +/- 1dB.

Receive Signal Path (Refer to Block Diagram)

Signals to and from the telephone line to the LiteLink™ appear on Tip and Ring connections. The receive signal is extracted from the transmit signal via the 2-4 wire hybrid block. The receive signal is then converted to infrared light by the receive photodiode amplifier and LED front end. The intensity of the infrared light is modulated by the receive signal and this light is transferred across the electrical isolation barrier via reflective dome to a photodiode where the light is converted to a photocurrent. This photocurrent is a highly linear representation of the receive signal and is amplified and converted to a voltage. This single ended voltage is converted to a differential voltage signal where it is presented as RX+ and RX- and connects to the receive inputs of the host data pump.

Variations in gain due to quantum efficiency of the optics are virtually eliminated by an on chip AGC circuit which automatically sets the input to output gain of the photoamplifier to unity. This means that the receive signal on the telephone line is faithfully reproduced at the RX outputs in terms of amplitude to within 2dB of the received signal. Distortion at the RX outputs is -80dB maximum at a receive level of -3dB over the band of 30Hz-4kHz.

Single supply operation requires that the RX outputs be biased at 2.5V DC, therefore, it is necessary to use 0.1uf blocking capacitors for coupling the receive signal to the host. Figures 2.4.A and 2.4.B. illustrate connection to the host differentially and single ended respectively.

Figure 2A Connection To Host Differential (Receive)

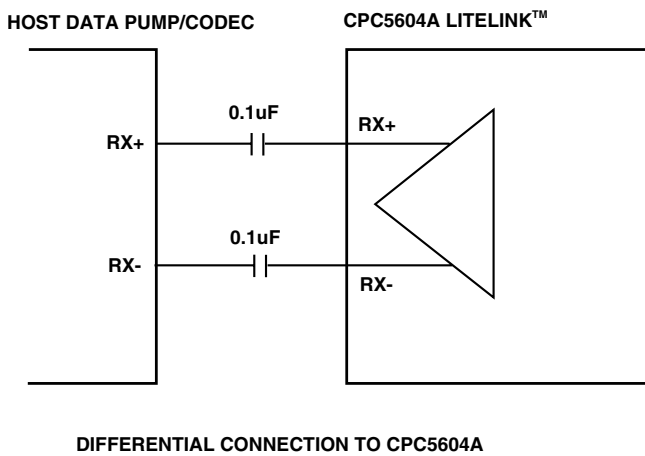

Transmit Signal Path (Refer to Block Diagram)

Signals that are to be sent from the host to the telephone line are placed differentially on TX+ and TX-. The maximum value of the transmit signal should not exceed 0dBm or 2.18Vpp. The differential transmit signal is converted to a single ended signal by the LiteLink™. This signal is coupled to the transmit photodiode amplifier in a similar manner to the receive path.

At the output of this amplifier the voltage signal is coupled to a voltage to current converter via a transconductance stage where the transmit signal modulates the telephone line loop current. As in the receive stage, the gain of the transmit photodiode amplifier is set to unity automatically thereby limiting insertion loss to 0±1dB. Figures 2C and 2D illustrate connection to the host differentially and single ended respectively.

Figure 2B Connection To Host Single Ended (Receive)

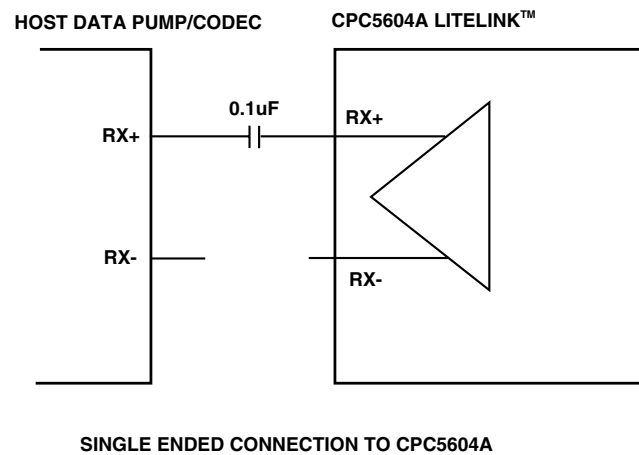
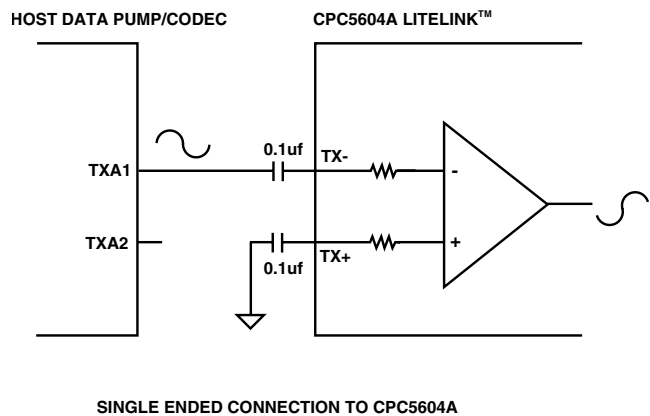

Figure 2C Connection To Host Differential (Transmit)



Ring Signal Detection

The snoop circuit actively monitors the telephone line for 2 conditions:

1. Incoming ring signal
2. Caller ID information

Figure 2D Connection To Host Single Ended (Transmit)

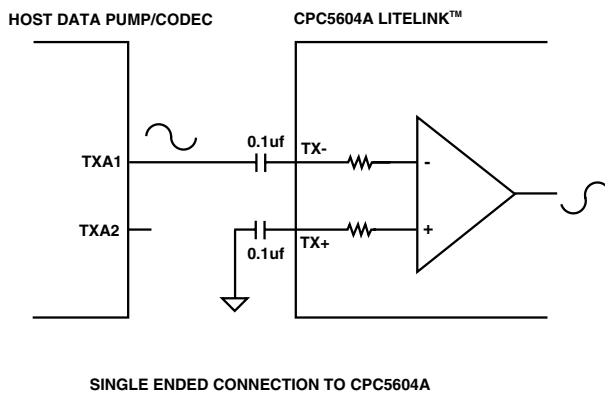

The Snoop circuit “snoops” the line continuously while the LiteLink™ is in the on-hook mode. Current taken from the telephone line in the on-hook condition by the LITELINK™ is maintained at a low 2uA maximum thus meeting regulatory requirements for minimum on-hook impedance limitation. When the central office places the ring signal on the telephone line, that signal is coupled through a pair of RC circuits to a differential amplifier in the LiteLink™.

Referring to Block Diagram, snoop capacitors connected to the SNP1/SNP2 pins provide a high voltage isolation barrier between the host and the telephone line while coupling the AC signals to the snoop amplifier. The ring signal is digitized and brought out to the RING pin where the host can qualify it as a valid ring signal.

The ring detection threshold is dependent on the values of 3 external components: RRXF (R3), RSNOOP (R5 or R6), and CS (C6 or C7). The default values in the typical bill of materials reflects the parameters in the data sheet for typical operation. If it is desired to change the threshold, the values can be selected by using the equation:

$$V_{RING(Peak)} = \left[\frac{330E-3}{5R_{RXF}} \right] \sqrt{(R_{SNOOP})^2 + \frac{1}{(2\pi f C_S)^2}}$$

Where f = ring frequency typically 20Hz.

Care should be taken when using this equation since RRXF (R3), CS (C6 or C7), and RSNOOP (R5 or R6) affect receive gain and Caller ID gain. It is recommended that RRXF (R3) be set to the typical value and then after adjusting the ring detect threshold, check that CID gain is acceptable.

Caller ID Detection

Caller ID (CID) is a service offered by the telephone company to provide caller information (i.e. caller's telephone number) to the called party. CID service is optional and signals only appear on the telephone lines of subscribers that pay for this feature. The CID information appears on the telephone line after the first ring burst is sent from the central office (CO).

Some of the characteristics of the CID signal are summarized below:

Parameter	Value
Signal Level	-13dBm
Link Type	Simplex, 2W
Transmission Scheme	Phase-coherent, FSK
Logical 1 (mark)	1200±12Hz
Logical 0 (Space)	2200± 22Hz
Transmission Rate	1200bps
Data	serial binary async
BER	< 10E -5
Bit Duration	833±50uS (same for start/stop as well)

Full details about the CID signal can be found in Bellcore document TR-TSY-000030, issue 1/1988.

Figure 2.7.A shows the CID timing diagram. Waveform #1 represents the Analog signals on the telephone line (amplitude not drawn to scale), waveform #2 is the digital RING detect output from the LiteLink™, waveform #3 is the CID input to the LiteLink™ from the Host. After the first ring burst is detected by the host, the host enables the CID line which automatically couples the snoop circuit to the RX outputs on the LiteLink™.

Figure 3 Caller ID Protocol

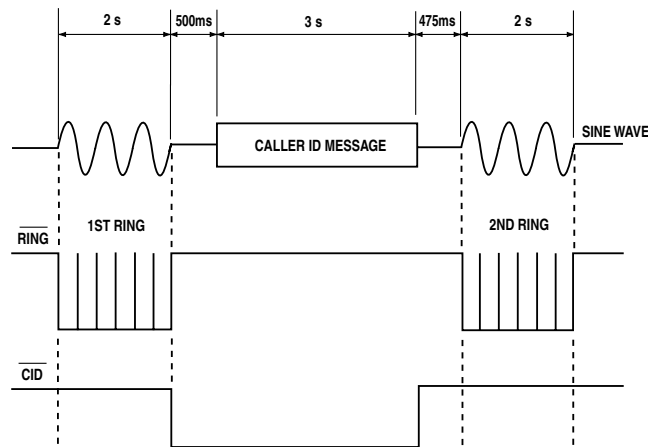

This CID signal is then processed by the host and, after processing, the host will deactivate the CID signal. At this point the host can answer the call if desired by asserting the OH pin on the LiteLink™. It's important to note that when the LiteLink™ goes off-hook, it automatically disconnects the snoop path from both the RX and Ring outputs. Signals appearing on the telephone line are now coupled through the optical isolation barrier in the LiteLink™ and not via the capacitors in the snoop path.

CID gain from Tip and Ring to Rx+ and Rx- is determined by:

$$GAIN = \frac{10 R_{RXF}}{\sqrt{(R_{SNOOP})^2 + \frac{1}{(2\pi f C_S)^2}}}$$

Where f = CID signal frequency

For example, with RRXF = 75KW, RSNOOP = 1.4MW, CS = 220pF, and f = 600Hz calculated GAIN = 0.707 or a loss of -3dB at Rx+ and Rx-. This implies that the snoop frequency response is 600Hz. Gain is expressed in decibels by:

DC characteristics

The LiteLink™ is designed to meet various country DC characteristics including the CTR-21 standard. The pins that control the VI characteristics and current limiting are designated ZDC and DCS. Meeting DC requirements are achieved by selecting the appropriate resistors R_{ZDC} (R16) and R_{DCS} (R20) respectively. Resistor values can also be switched in and out with the CPC5601 device or optocouplers which enables international compliance under software control. Suggested resistor values for various countries are listed in table 1. The VI profile on Tip and Ring is described by the following equation:

$$V_{LINE} = V_{BRIDGE} + \left[\frac{R_{DCS} + 12M\Omega}{R_{DCS}} \right] \left[0.5V + (I_{LINE} - 8mA)R_{ZDC} \right]$$

Example: I_{LINE} = 20mA, V_{BRIDGE} = 1.2V, R_{DCS} = 1.69MW, R_{ZDC} = 8W, V_{LINE} = 6.0V.

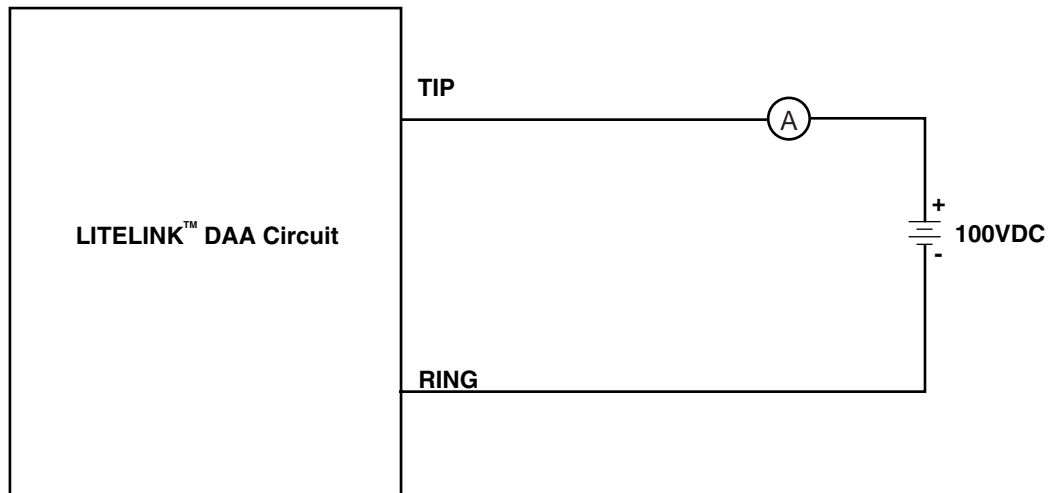
Figure 4 On-Hook DC Resistance Tip/Ring Setup

On-Hook Resistance

Figure 4 shows the test setup for on-hook DC resistance. The battery is set to 100VDC and an ammeter is placed in series with the battery connection. When the DAA is in the on-hook state, the leakage current is obtained and then the battery voltage is divided by this current yielding the on-hook resistance. The LiteLink™ is guaranteed to have a leakage current < 10uA at 100V which is equivalent to an on-hook resistance > 10MΩ thus meeting regulatory approvals.

Current Limiting

The LiteLink™ includes a current limiting feature that is selectable via resistor R_{ZDC} (R16). The current limit value is set by the equation:

$$10 \left[\frac{1V}{R_{ZDC}} \right] 12$$

For US/Canada/Japan the recommended value for R_{ZDC} (R16) is 8Ω which yields a current limit value of 133mA. The current limiting feature is especially useful in the case where the host system is inadvertently connected to a digital PBX telephone port which usually has a very high current limit value. The current limiting capability will prevent damage to the LiteLink™ in this scenario.

CTR-21 Compliance

CTR-21 is the standard for connection of data communications equipment to the European telephone network. The maximum current limit requirement in CTR-21 (Section 4.7.1) is 60mA and can be selected by the following equation:

$$ILM = \left[\frac{1V}{R_{ZDC}} \right] + 8mA$$

Clare recommends current limit be set to 53mA using an R_{ZDC} value of 22Ω. Since V_{DD} is regulated to +3.5V, excess power is dissipated in the external MOSFET package. Since the maximum off-hook line voltage and current in CTR-21 is 40V and 53mA respectively, the maximum power dissipated by the MOSFET is approximately 2.1W.

AC Characteristics

In a similar manner to the DC characteristics, AC termination impedance is set via R_{ZNT} (R18). For all applications, a 604W resistor for R_{ZNT} (R18) is required to reflect 600W to the CO.

Differential and Single Ended Mode

The LiteLink™ is designed to support either differential or single ended signals on Tx and/or Rx pins. The decision of which topology to use is based on the particular chipset being used to drive the LiteLink™. For example, most Lucent modem chips require both differential

receive and transmit ability, while most Rockwell devices require differential transmit and single ended receive. The LiteLink™ supports a full 0dBm differential signal on its Tx inputs.

Receive and Transmit Frequency Response

Figures 4A and 4C show the test circuits for receive and transmit frequency response respectively. Figures

4B and 4D show the graphs for receive and transmit frequency response respectively.

Figure 4A Receive Frequency Response Setup

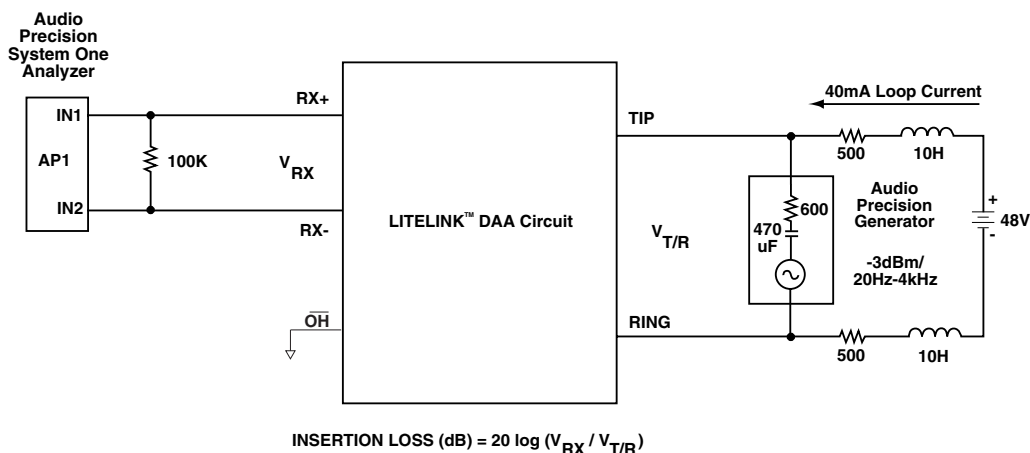

Figure 4B Receive Frequency Response Rx+

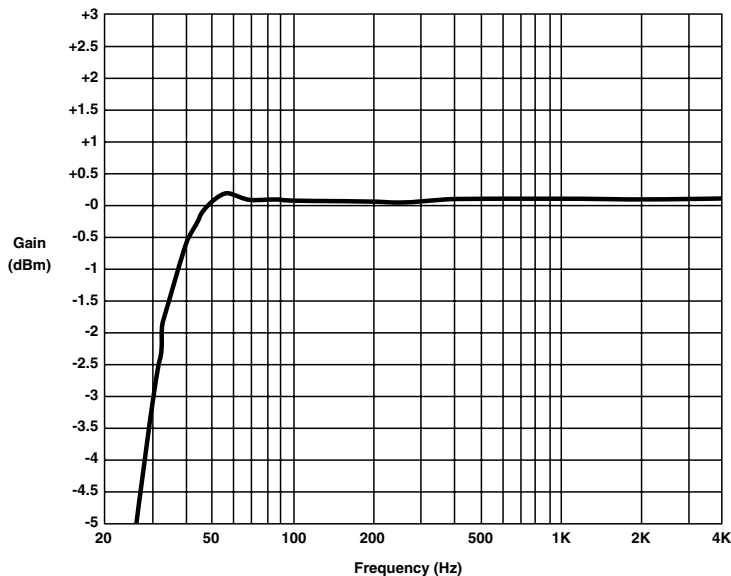

Figure 4C Transmit Frequency Response Setup

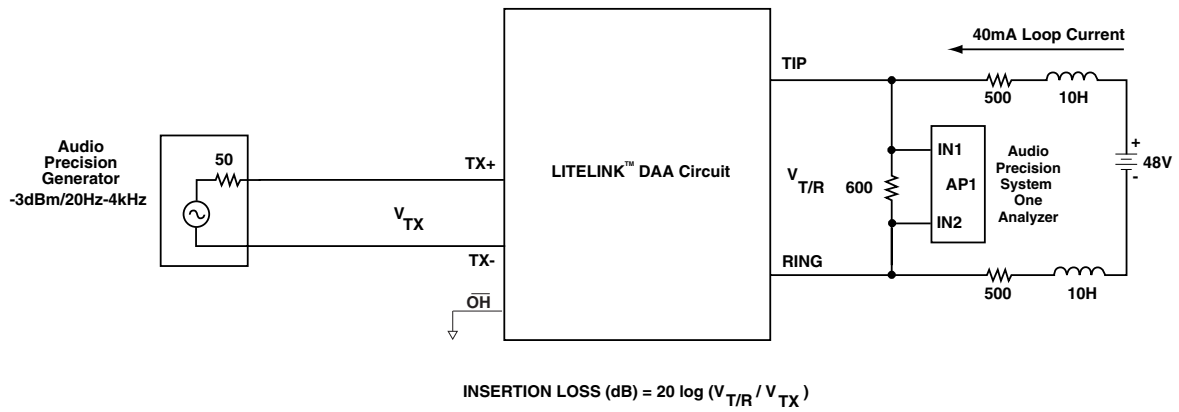
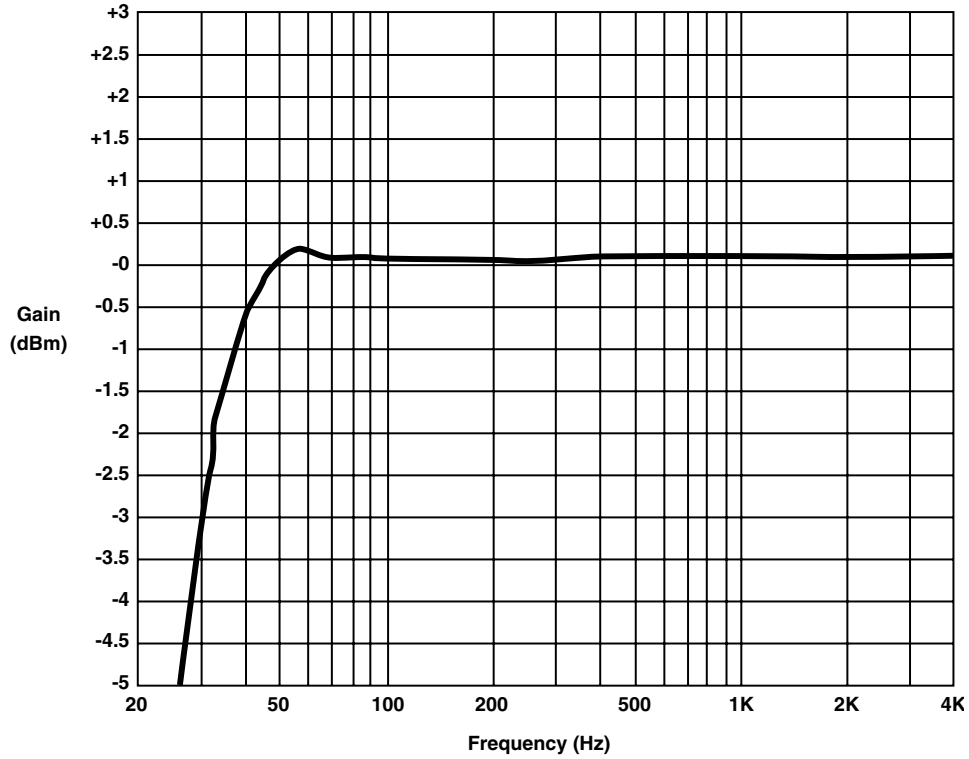

Figure 4D Transmit Frequency Response Tx±



Distortion

Figures 5A and 5C show the test setup for receive and transmit distortion. Figures 5B and 5.D show the THD at 600Hz graphs for receive and transmit respectively. Transmit signal for this test is set to -9dBm.

Figure 5A Receive Distortion Test Tip/Ring to Rx± Setup

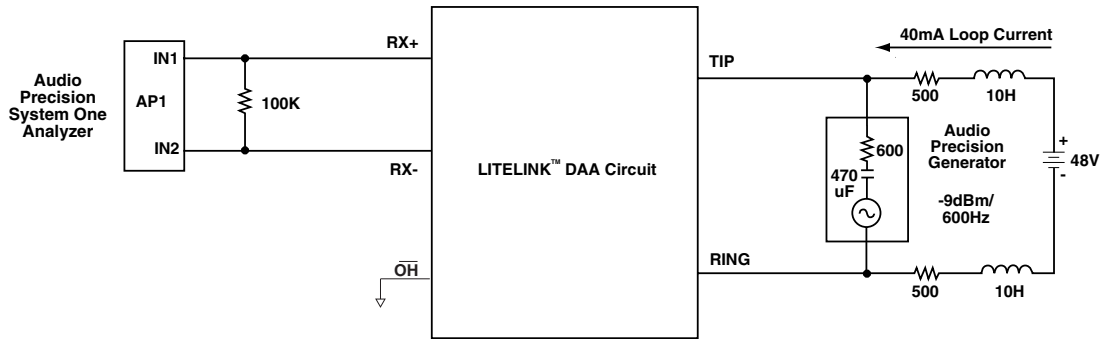

Figure 5B Receive Distortion on Rx±

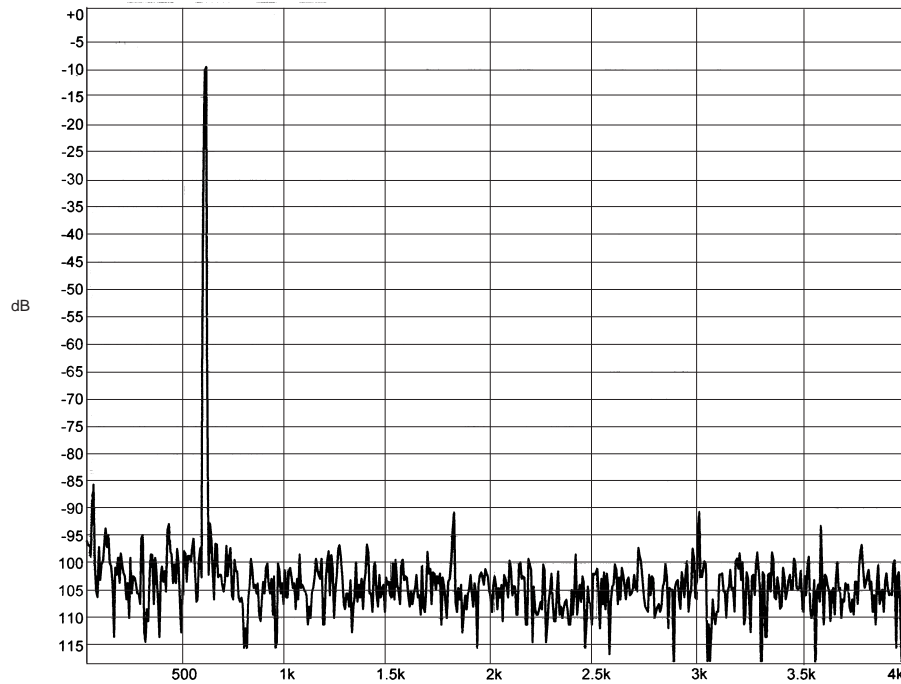

Figure 5C Transmit Distortion Test Tx± to Tip/Ring Setup

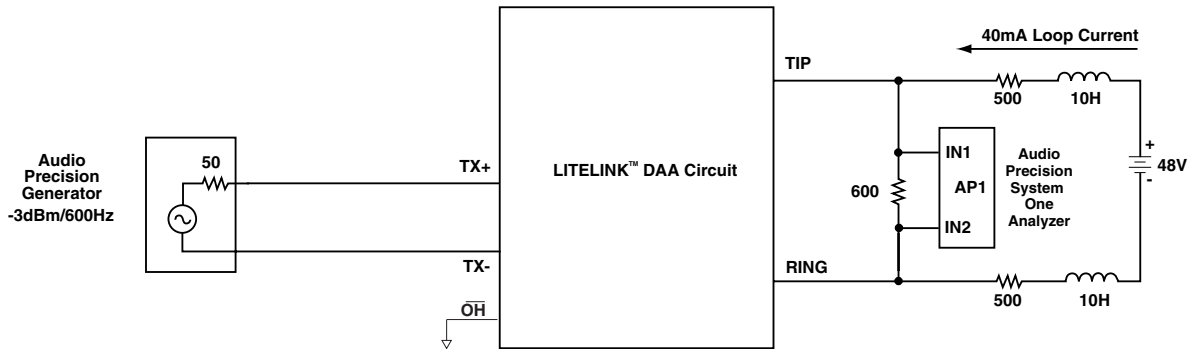
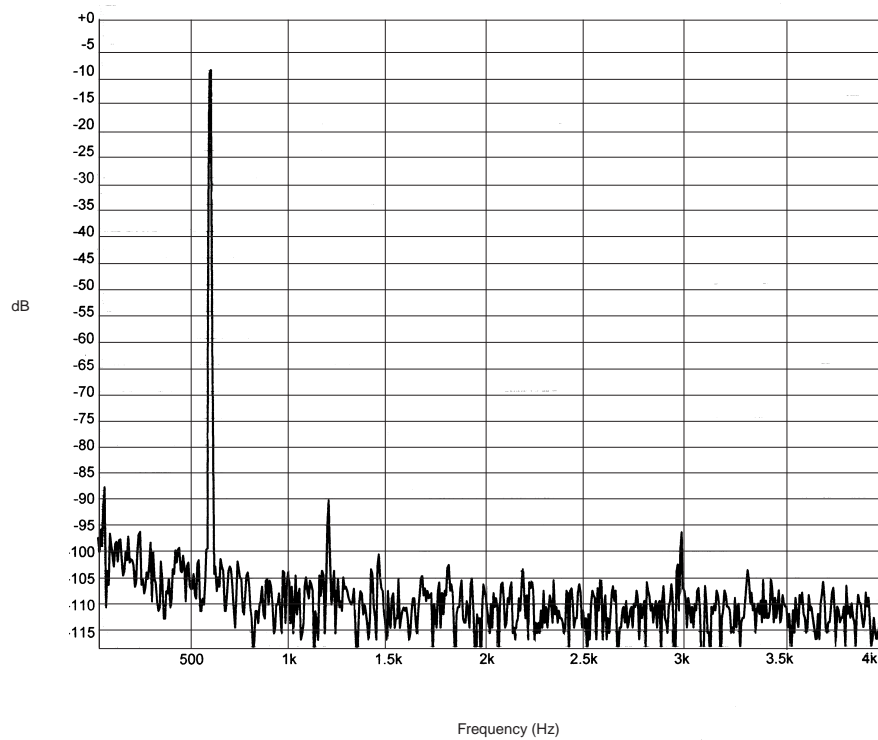

Figure 5D Transmit Distortion on Tip/Ring



Trans-Hybrid Loss

As shown in Figure 6A, the Audio Precision, AP1 injects a signal into the Tx inputs and measures the energy at Rx with Tip and Ring terminated by a 600Ω nominal

impedance. The Tx input frequency is swept from 30Hz-4000Hz and the amplitude of the signal is measured on the Rx inputs and graphed in Figure 6B.

Figure 6A Trans-Hybrid Loss (THL) Test Setup

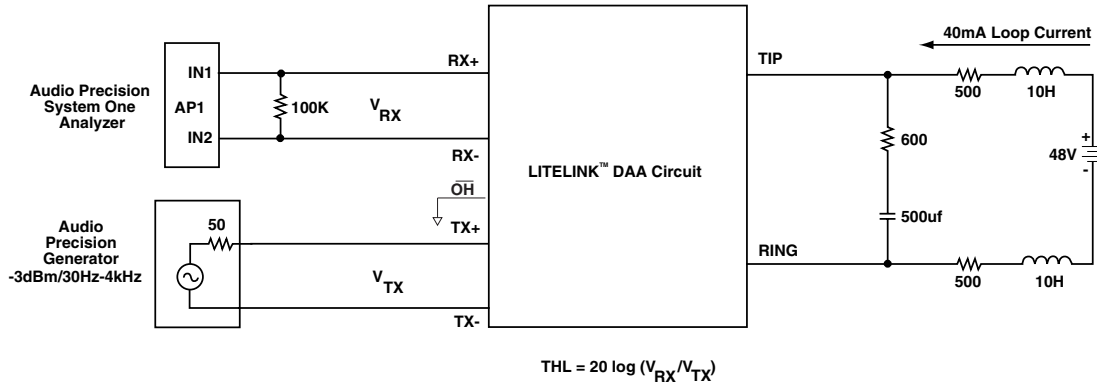
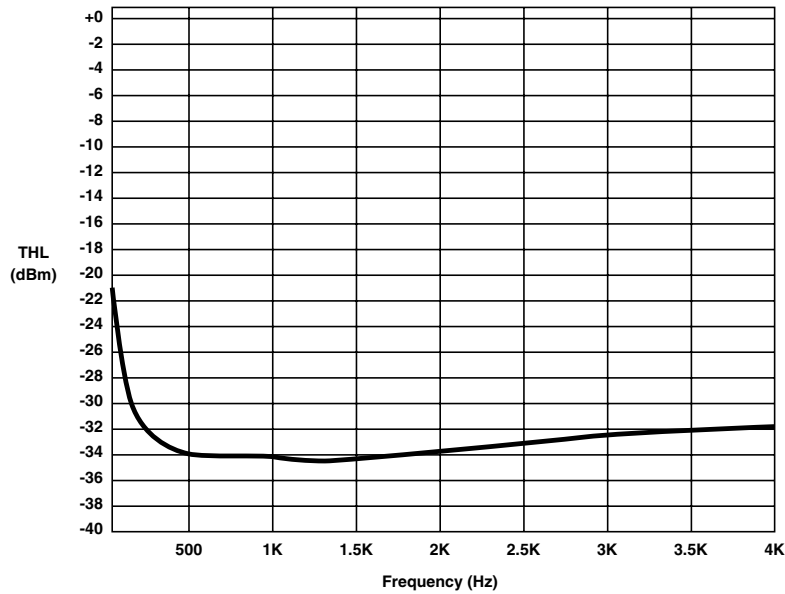

Figure 6B Trans-Hybrid Loss at Rx± with -3dBm Signal on Tx± Matched to 600Ω Impedance on T/R



Return Loss

The return loss is a measure of impedance mismatch between a terminating impedance (DAA) and a source impedance (reference impedance). The AP measures the return loss vs. frequency with the addition of the bridge circuit show in Figure 7A. For this test, the refer-

ence impedance is set by the 600Ω nominal impedance, Z_{REF} . The impedance that this is to be compared to is across Tip and Ring connections. The AP sweeps frequency and graphs frequency vs. return loss as shown in Figure 7B.

Figure 7A Return Loss Test Setup

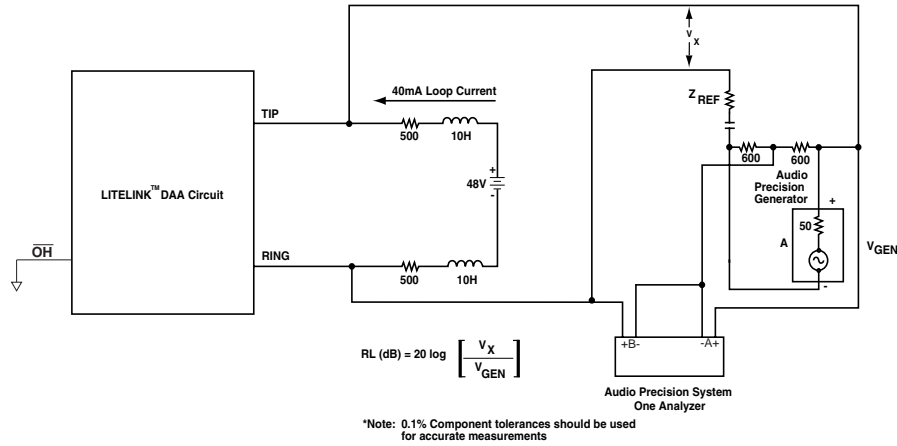
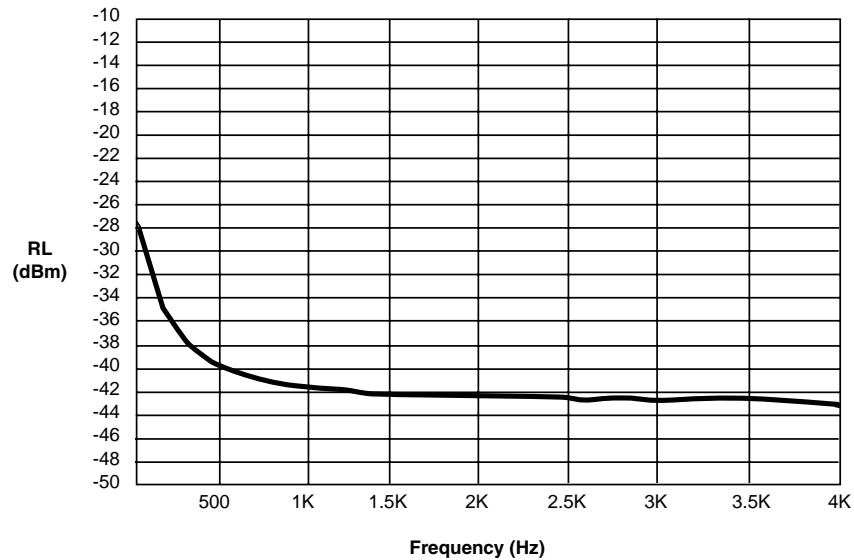

Figure 7B Return Loss



Snoop Mode Frequency Response

Figure 8A can be used as a reference test setup for this test with the difference being that the DAA is now in the on-hook mode. In the on-hook mode, the snoop circuit

path is the signal path from Tip and Ring to Rx through the capacitive barrier CS instead of the optical path. Snoop frequency response graph is shown in Figure 8B.

Figure 8A Snoop Mode Frequency Response Setup

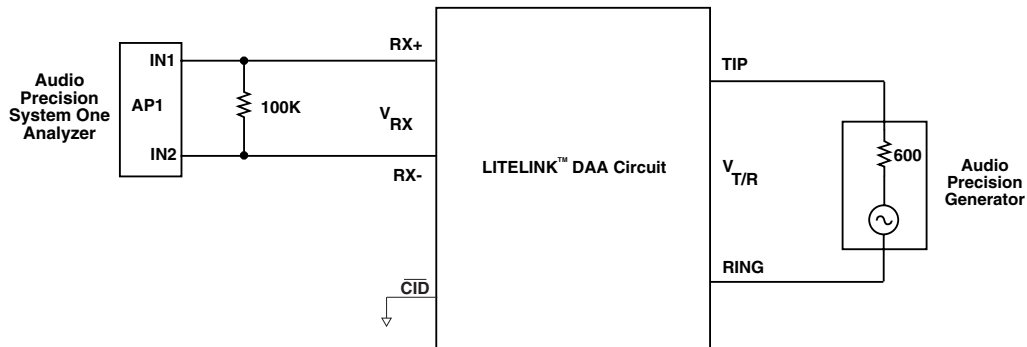
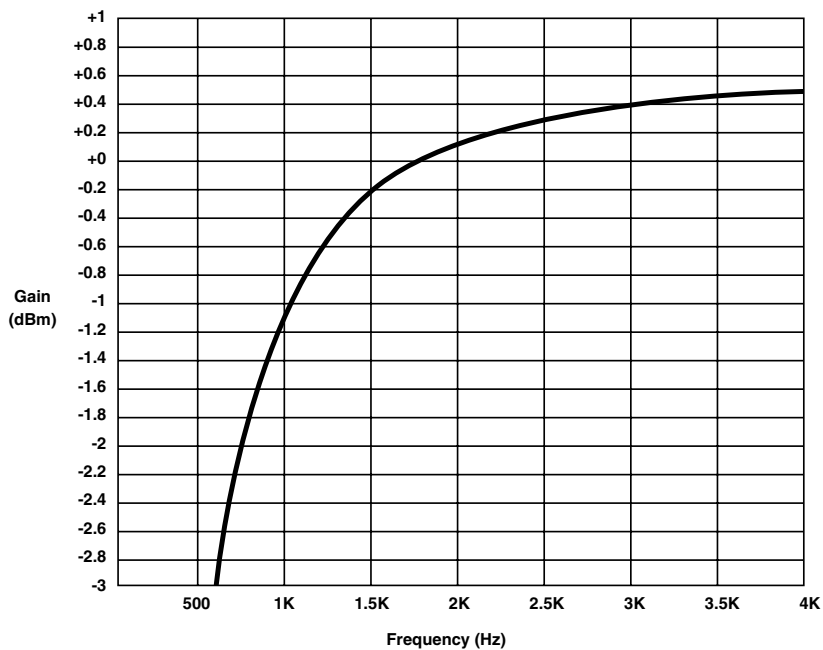

Figure 8B Snoop Mode Frequency Response At Rx±



Snoop Mode Distortion

Figure 9A can be used for the snoop mode distortion test. Snoop mode operation requires that the DAA be in the on-hook state and the $\overline{\text{CID}}$ pin asserted (driven Low). Distortion in the snoop mode is not critical since

signals coupled through the snoop circuit are either 20Hz ring signals or FSK CID signals. A graph of THD+N for the snoop mode is shown in Figure 9B.

Figure 9A Snoop Mode Distortion Setup

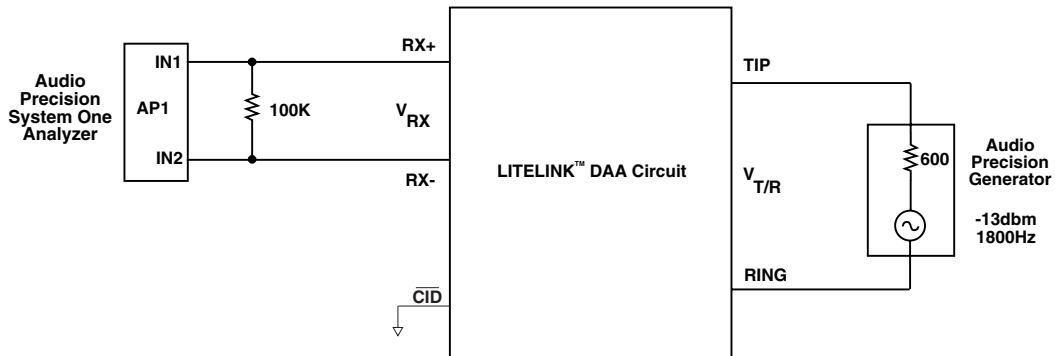
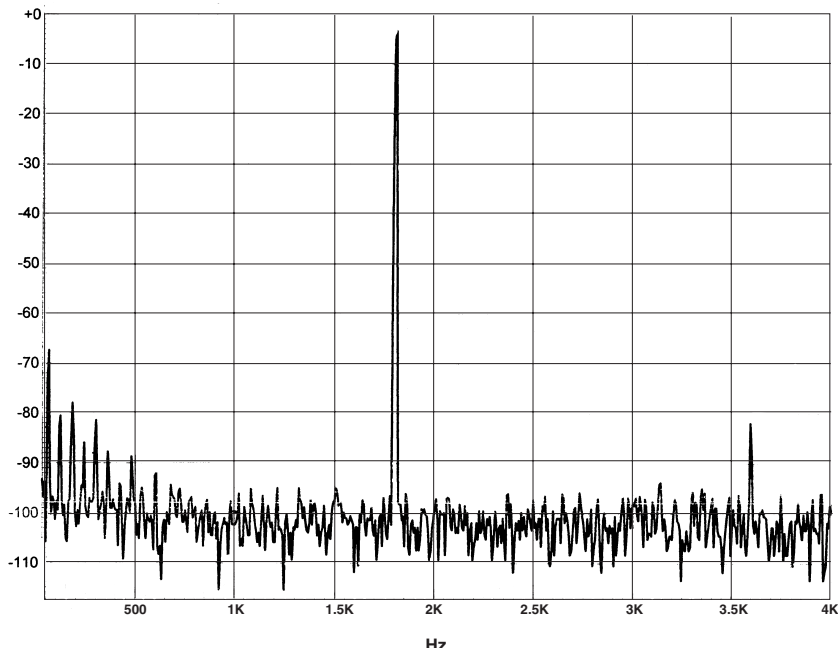

Figure 9B Snoop Mode THD + N



Snoop Mode Common Mode Rejection Ratio (CMRR)

As a practical matter, CMRR is dependent on how well the external snoop network CS and RSNOOP are matched. It is recommended that capacitors CS (C6 or C7) be ceramic NPO (COG) type for excellent temperature stability and have a tolerance of 5% or less. Resistor tolerance for RSNOOP (R5 or R6) should also be at least 5% or better.

Careful consideration should be taken related to PCB layout of the snoop network. Traces should be as short

as possible and kept equidistant from one another. Spacing of 0.1" should be maintained between traces on the phone line side. If possible, traces should be routed away from large 60Hz fields to prevent noise inducement into the snoop circuit.

Figure 10A shows the test setup for CMRR through the snoop signal path. For this test the LITELINK™ is on-hook and the frequency is swept from 20Hz to 4kHz. Figure 10B is a graph of CMRR vs. frequency.

Figure 10A Snoop Mode Common Mode Rejection Ratio Setup

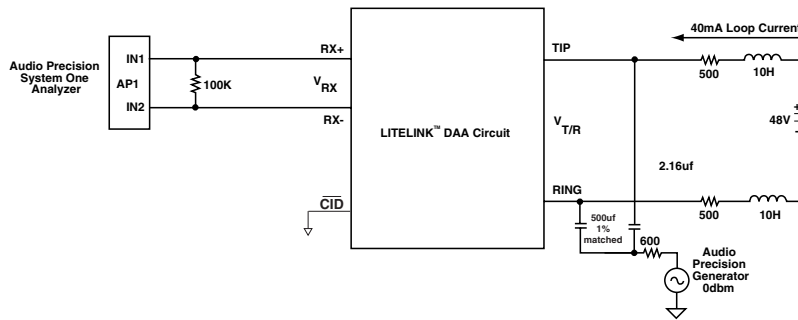
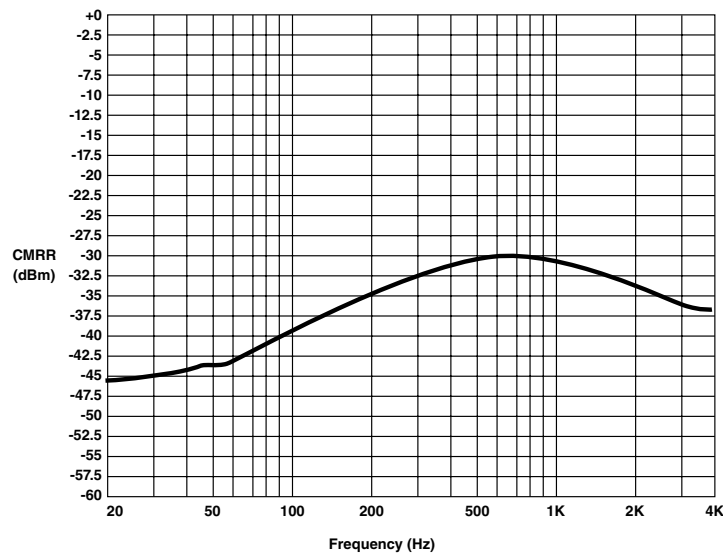

Figure 10B Common Mode Rejection



Country Specific Component Values

	RZDC	ZZNT
US/Far East	8.2W	600W
CTR-21	22.1W	600W

CTR-21 Countries:

- UK
- France
- Germany
- Spain
- Switzerland
- Italy
- Luxembourg
- Holland
- Belgium
- Netherlands
- Australia

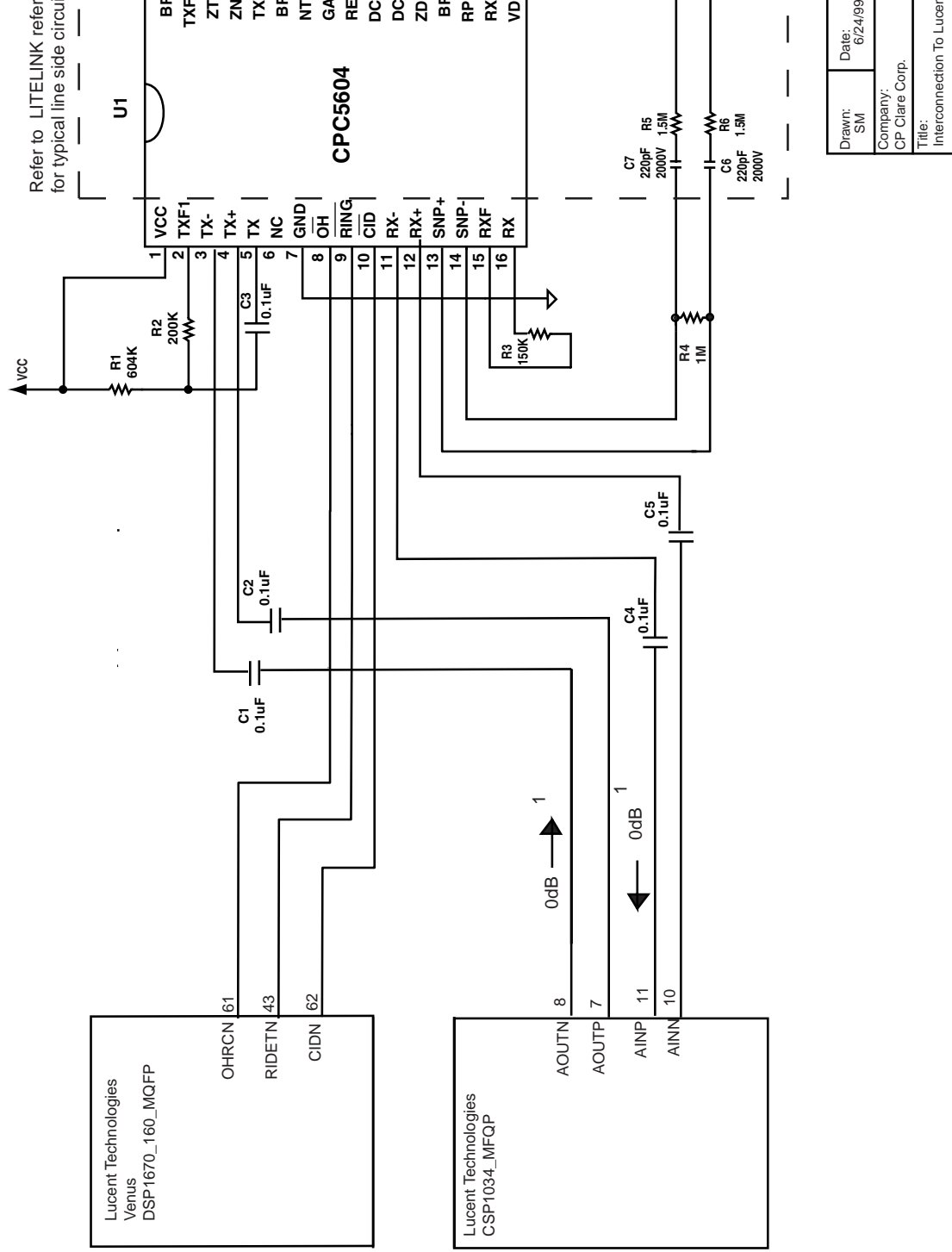

1. Lucent chips expect a zero dB drop between the codec and Tip and Ring.

ALL RES UNLESS

Mechanical Dimensions

32 Pin SOIC

Recommended Pad Layout

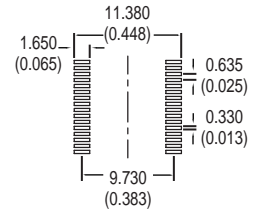
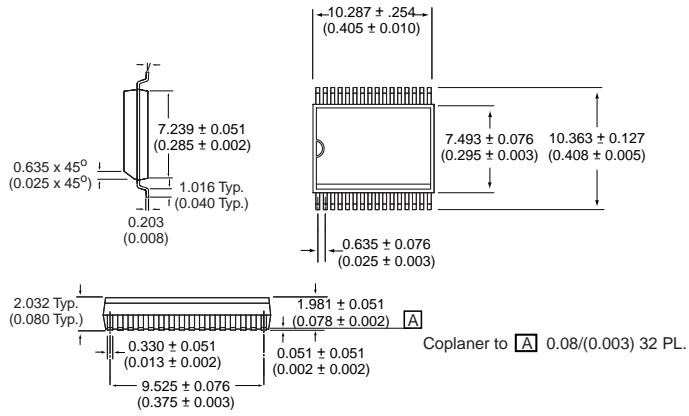

Dimensions
mm
(inches)



CLARE

For additional information please visit our website at: www.clare.com

Clare, Inc. makes no representations or warranties with respect to the accuracy or completeness of the contents of this publication and reserves the right to make changes to specifications and product descriptions at any time without notice. Neither circuit patent licenses nor indemnity are expressed or implied. Except as set forth in Clare's Standard Terms and Conditions of Sale, Clare, Inc. assumes no liability whatsoever, and disclaims any express or implied warranty, relating to its products including, but not limited to, the implied warranty of merchantability, fitness for a particular purpose, or infringement of any intellectual property right.

The products described in this document are not designed, intended, authorized or warranted for use as components in systems intended for surgical implant into the body, or in other applications intended to support or sustain life, or where malfunction of Clare's product may result in direct physical harm, injury, or death to a person or severe property or environmental damage. Clare, Inc. reserves the right to discontinue or make changes to its products at any time without notice.

Specification: DS-CPC5604-RXX
©Copyright 2002, Clare, Inc.
All rights reserved. Printed in USA.
6/25/02

Looking for pricing, stock, or lifecycle information?

Click below to explore more details on WIN SOURCE:

 [View CPC5604A on WIN SOURCE](#)

 [IXYS Information](#)

Optimize Your Supply Chain with WIN SOURCE Solutions

-  Global Sourcing Solution
-  Obsolete Management
-  Cost Control Management
-  Shortage Management
-  Alternative Solution
-  Excess Inventory Management