



THE DATASHEET OF BT816Q-R



Bridgetek Pte Ltd

BT81X (815/6) Advanced Embedded Video Engine Datasheet



The BT81X Series is an easy to use graphic controllers targeted at embedded applications to generate high-quality Human Machine Interfaces (HMIs). It has the following features:

- Advanced Embedded Video Engine(EVE) with high resolution graphics and video playback
- BT815/6 functionality includes graphic control, audio control, and touch control interface.
- Support multiple widgets for simplified design implementation
- Built-in graphics operations allow users with little expertise to create high-quality displays
- Support Adaptive Scalable Texture Compression (ASTC) format to save considerable memory space for larger fonts and graphics images
- Support external QSPI NOR flash up to 2Gbit to store and fetch graphic elements (image, font, widget etc.)
- Support 4-wire resistive touch screen (BT816)
- Support capacitive touch screen with up to 5 touch point detection (BT815)
- Hardware engine can recognize touch tags and track touch movement. Provides notification for up to 255 touch tags.
- Enhanced sketch processing
- Built-in 12MHz crystal oscillator with PLL providing programmable system clock up to 72MHz
- Support crystal-less operation with internal relaxation clock source
- Video RGB parallel output; configurable to support PCLK up to 72MHz and R/G/B output of 1 to 8 bits
- Programmable timing to adjust HSYNC and VSYNC timing, enabling interface to numerous displays
- Support for LCD display with resolution up to SVGA (800x600) and formats with data enable (DE) mode or VSYNC/HSYNC mode
- Support landscape and portrait orientations
- Display enable control output to LCD panel
- Integrated 1MByte graphics RAM, no frame buffer RAM required
- Support playback of motion-JPEG encoded AVI videos
- Mono audio channel output with Sigma-delta modulation
- Built-in sound synthesizer
- Audio wave playback for mono 8-bit linear PCM, 4-bit ADPCM and μ -Law coding format at sampling frequencies from 8 kHz to 48 kHz. Built-in digital filter reduces the system design complexity of external filtering
- PWM output for display backlight dimming control
- Advanced object oriented architecture enables low cost MPU/MCU as system host using SPI interfaces
- Support SPI data lines in single, dual or quad mode; SPI clock up to 30MHz
- Power mode control allows the chip to be put in power down, sleep and standby states
- Supports I/O voltage from 1.8V to 3.3V
- Internal voltage regulator supplies 1.2V to the digital core
- Built-in Power-on-reset circuit
- -40°C to 85°C extended operating temperature range
- Available in a compact Pb-free, VQFN-64 package, RoHS compliant

Neither the whole nor any part of the information contained in, or the product described in this manual, may be adapted or reproduced in any material or electronic form without the prior written consent of the copyright holder. This product and its documentation are supplied on an as-is basis and no warranty as to their suitability for any particular purpose is either made or implied. Bridgetek Pte Ltd will not accept any claim for damages howsoever arising as a result of use or failure of this product. Your statutory rights are not affected. This product or any variant of it is not intended for use in any medical appliance, device or system in which the failure of the product might reasonably be expected to result in personal injury. This document provides preliminary information that may be subject to change without notice. No freedom to use patents or other intellectual property rights is implied by the publication of this document. Bridgetek Pte Ltd, 178 Paya Lebar Road, #07-03, Singapore 409030. Singapore Registered Company Number: 201542387H

1 Typical Applications

- Point of Sales Machines
- Multi-function Printers
- Instrumentation
- Home Security Systems
- Graphic touch pad – remote, dial pad
- Tele / Video Conference Systems
- Phones and Switchboards
- Medical Appliances
- Blood Pressure displays
- Heart monitors
- Glucose level displays
- Breathalyzers
- Gas chromatographs
- Power meter
- Home appliance devices
- Set-top box
- Thermostats
- Sprinkler system displays
- Medical Appliances
- GPS / Satnav
- Vending Machine Control Panels
- Elevator Controls
-and many more

1.1 Part Numbers

Part Number	Description	Package
BT815Q-x	EVE with ASTC and external NOR flash, capacitive touch	64 Pin VQFN, body 9 x 9 mm, pitch 0.5mm
BT816Q-x	EVE with ASTC and external NOR flash, resistive touch	64 Pin VQFN, body 9 x 9 mm, pitch 0.5mm

Table 1- BT815/6 Embedded Video Engine Part Numbers

Note: Packaging codes for x is:

-R: Taped and Reel (3000 pcs per reel)

-T: Tray packing (260 pcs per tray)

For example: BT815Q-R is 3000 VQFN pieces in taped and reel packaging

2 Block Diagram

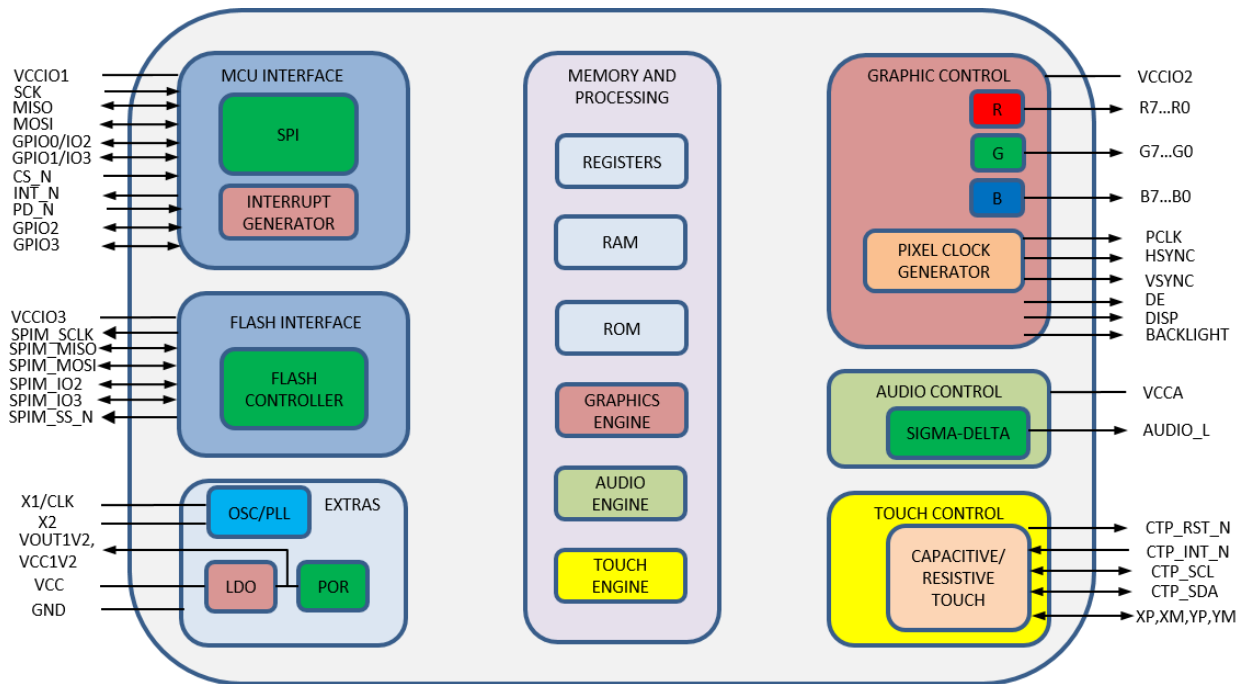

Figure 2-1 BT815/6 Block Diagram

For a description of each function please refer to Section 4.

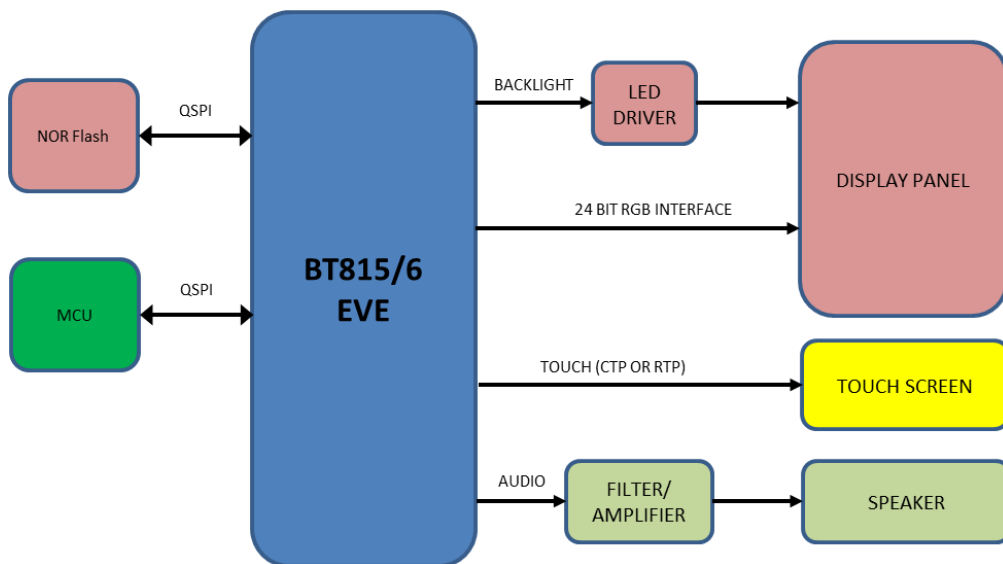

Figure 2-2 BT815/6 System Design Diagram

BT815/6 with EVE (Embedded Video Engine) technology simplifies the system architecture for advanced human machine interfaces (HMIs) by providing support for display, audio, and touch as well as an object oriented architecture approach that extends from display creation to the rendering of the graphics.

Table of Contents

1	Typical Applications.....	2
1.1	Part Numbers.....	2
2	Block Diagram	3
3	Device Pin Out and Signal Description.....	7
3.1	BT815 VQFN-64 Package Pin Out.....	7
3.2	BT816 VQFN-64 Package Pin Out.....	7
3.3	Pin Description	8
4	Functional Description.....	12
4.1	Quad SPI Host Interface	12
4.1.1	QSPI Interface.....	12
4.1.2	Serial Data Protocol.....	14
4.1.3	Host Memory Read	14
4.1.4	Host Memory Write.....	15
4.1.5	Host Command	15
4.1.6	Interrupts	19
4.2	System Clock	20
4.2.1	Clock Source	20
4.2.2	Phase Locked Loop.....	21
4.2.3	Clock Enable.....	21
4.2.4	Clock Frequency.....	21
4.3	Graphics Engine	21
4.3.1	Introduction	21
4.3.2	ASTC.....	22
4.3.3	ROM and RAM Fonts	22
4.4	SPI NOR Flash Interface	26
4.5	Parallel RGB Interface	26
4.6	Miscellaneous Control	29
4.6.1	Backlight Control Pin	29
4.6.2	DISP Control Pin	29
4.6.3	General Purpose IO pins	29
4.6.4	Pins Drive Current Control.....	30
4.7	Audio Engine.....	30
4.7.1	Sound Synthesizer	30
4.7.2	Audio Playback	32

4.8	Touch-Screen Engine	33
4.8.1	Resistive Touch Control.....	33
4.8.2	Capacitive Touch Control.....	34
4.8.3	Compatibility Mode.....	34
4.8.4	Extended Mode	35
4.8.5	Short-Circuit Protection.....	35
4.8.6	Capacitive Touch Configuration	35
4.8.7	Host Driven Multi-Touch.....	35
4.8.8	Touch Detection in none-ACTIVE State	37
4.9	Power Management	37
4.9.1	Power Supply	37
4.9.2	Internal Regulator and POR	38
4.9.3	Power Modes	38
4.9.4	Reset and Boot-up Sequence	40
4.9.5	Pin Status at Different Power States	40
5	Memory Map	42
5.1	Registers.....	42
5.2	Chip ID.....	47
6	Devices Characteristics and Ratings	48
6.1	Absolute Maximum Ratings.....	48
6.2	ESD and Latch-up Specifications	48
6.3	DC Characteristics.....	48
6.4	AC Characteristics	51
6.4.1	System Clock and Reset.....	51
6.4.2	SPI Interface Timing.....	52
6.4.3	RGB Interface Timing	53
7	Application Examples	54
8	Package Parameters.....	56
8.1	Part Markings	56
8.1.1	Top Side	56
8.1.2	Bottom Side	56
8.2	VQFN-64 Package Dimensions	57
8.3	Solder Reflow Profile	57
9	Contact Information	59
	Appendix A – References	60

Document References	60
Acronyms and Abbreviations.....	60
Appendix B - List of Figures and Tables	62
List of Figures	62
List of Tables.....	62
Appendix C - Revision History	64

3 Device Pin Out and Signal Description

3.1 BT815 VQFN-64 Package Pin Out

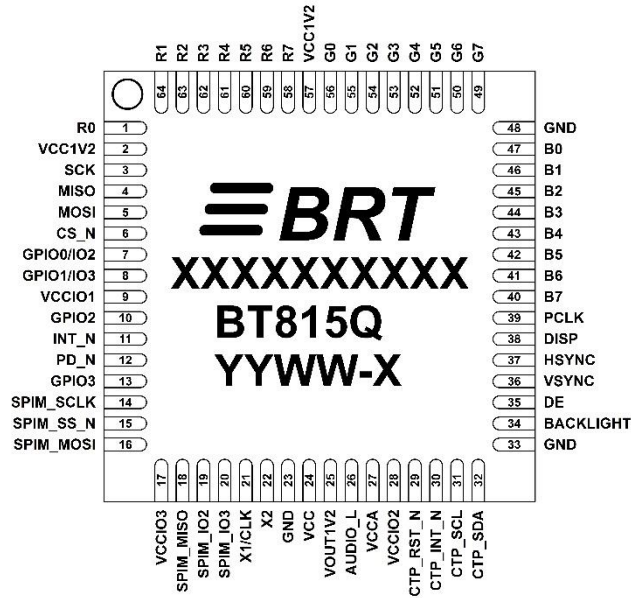

Figure 3-1 Pin Configuration BT815 VQFN-64(Top View)

3.2 BT816 VQFN-64 Package Pin Out

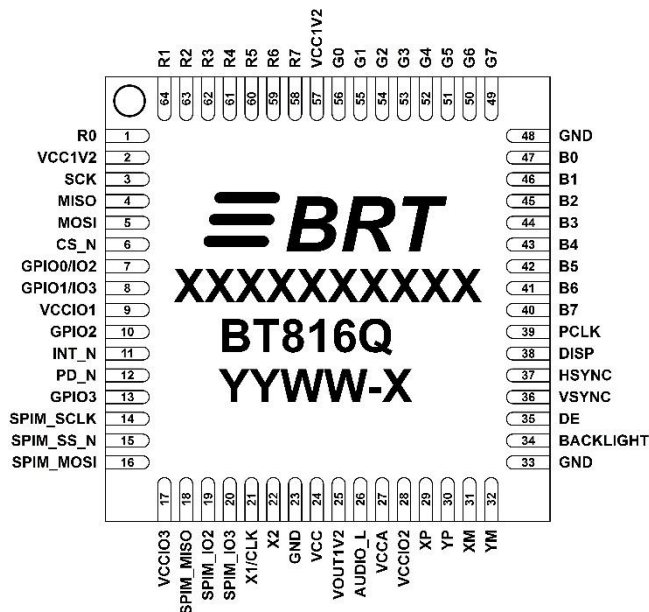

Figure 3-2 Pin Configuration BT816 VQFN-64 (Top View)

3.3 Pin Description

Pin Number		Pin Name	Type	Description
BT815	BT816			
1	1	R0	O	Bit 0 of Red RGB signals Powered from pin VCCIO2
2	2	VCC1V2	P	1.2V digital core supply. Connect to VOUT1V2 pin.
3	3	SCK	I	SPI clock input Powered from pin VCCIO1
4	4	MISO	I/O	SPI Single mode: SPI MISO output SPI Dual/Quad mode: SPI data line 1 Powered from pin VCCIO1
5	5	MOSI	I/O	SPI Single mode: SPI MOSI input SPI Dual/Quad mode: SPI data line 0 Powered from pin VCCIO1
6	6	CS_N	I	SPI slave select input Powered from pin VCCIO1
7	7	GPIO0/IO2	I/O	SPI Single/Dual mode: General purpose IO 0 SPI Quad mode: SPI data line 2 Powered from pin VCCIO1
8	8	GPIO1/IO3	I/O	SPI Single/Dual mode: General purpose IO 1 SPI Quad mode: SPI data line 3 Powered from pin VCCIO1
9	9	VCCIO1	P	I/O power supply for host interface pins. Support 1.8V, 2.5V or 3.3V.
10	10	GPIO2	I/O	General purpose IO 2 Powered from pin VCCIO1
11	11	INT_N	OD/O	Interrupt to host, open drain output(default) or push-pull output, active low
12	12	PD_N	I	Chip power down mode control input, active low. Connect to MCU GPIO for power management or hardware reset function, or pulled up to VCCIO1 through 47kΩ resistor and 100nF to ground. Powered from pin VCCIO1
13	13	GPIO3	I/O	General purpose IO 3 Powered from pin VCCIO1
14	14	SPIM_SCLK	O	SPI flash clock output line Powered from pin VCCIO3
15	15	SPIM_SS_N	O	SPI flash chip select output line Powered from pin VCCIO3
16	16	SPIM_MOSI	I/O	SPI flash MOSI line Powered from pin VCCIO3

Pin Number		Pin Name	Type	Description
BT815	BT816			
17	17	VCCIO3	P	I/O power supply for SPIM pins. Support 1.8V, 2.5V or 3.3V. VCCIO3 can be connected to different voltage with VCCIO1 or VCCIO2.
18	18	SPIM_MISO	I/O	SPI flash MISO line Powered from pin VCCIO3
19	19	SPIM_IO2	I/O	SPI flash IO2 line Powered from pin VCCIO3
20	20	SPIM_IO3	I/O	SPI flash IO3 line Powered from pin VCCIO3
21	21	X1/CLK	I	Crystal oscillator or clock input 3.3V peak input allowed. Powered from pin VCC.
22	22	X2	O	Crystal oscillator output Powered from pin VCC.
23	23	GND	P	Ground
24	24	VCC	P	3.3V power supply input.
25	25	VOUT1V2	P	1.2V regulator output pin. Connect a 4.7uF decoupling capacitor to GND.
26	26	AUDIO_L	O	Audio Sigma-delta output Powered from pin VCCA
27	27	VCCA	P	3.3V power supply input.
28	28	VCCIO2	P	I/O power supply for RGB and touch pins. Supports 1.8V, 2.5V or 3.3V. VCCIO2 can be connected to different voltage with VCCIO1 or VCCIO3.
-	29	XP	AI/O	Connect to X right electrode of 4-wire resistive touch-screen panel. Powered from pin VCCIO2.
-	30	YP	AI/O	Connect to Y top electrode of 4-wire resistive touch-screen panel. Powered from pin VCCIO2.
-	31	XM	AI/O	Connect to X left electrode of 4-wire resistive touch-screen panel. Powered from pin VCCIO2.
-	32	YM	AI/O	Connect to Y bottom electrode of 4-wire resistive touch-screen panel. Powered from pin VCCIO2.
29	-	CTP_RST_N	O	Connect to reset pin of the CTPM. Powered from pin VCCIO2.
30	-	CTP_INT_N	I/O	Connect to interrupt pin of the CTPM. Powered from pin VCCIO2.

Pin Number		Pin Name	Type	Description
BT815	BT816			
31	-	CTP_SCL	I/OD	Connect to I2C SCL pin of the CTPM. Powered from pin VCCIO2.
32	-	CTP_SDA	I/OD	Connect to I2C SDA pin of the CTPM. Powered from pin VCCIO2.
33	33	GND	P	Ground
34	34	BACKLIGHT	O	LED Backlight brightness PWM control signal. Powered from pin VCCIO2.
35	35	DE	O	LCD Data Enable. Powered from pin VCCIO2.
36	36	VSYNC	O	LCD Vertical Sync. Powered from pin VCCIO2.
37	37	HSYNC	O	LCD Horizontal Sync. Powered from pin VCCIO2.
38	38	DISP	O	LCD Display Enable. Powered from pin VCCIO2.
39	39	PCLK	O	LCD Pixel Clock. Powered from pin VCCIO2.
40	40	B7	O	Bit 7 of Blue RGB signals. Powered from pin VCCIO2.
41	41	B6	O	Bit 6 of Blue RGB signals. Powered from pin VCCIO2.
42	42	B5	O	Bit 5 of Blue RGB signals. Powered from pin VCCIO2.
43	43	B4	O	Bit 4 of Blue RGB signals. Powered from pin VCCIO2.
44	44	B3	O	Bit 3 of Blue RGB signals. Powered from pin VCCIO2.
45	45	B2	O	Bit 2 of Blue RGB signals. Powered from pin VCCIO2.
46	46	B1	O	Bit 1 of Blue RGB signals. Powered from pin VCCIO2.
47	47	B0	O	Bit 0 of Blue RGB signals. Powered from pin VCCIO2.
48	48	GND	P	Ground
49	49	G7	O	Bit 7 of Green RGB signals. Powered from pin VCCIO2.
50	50	G6	O	Bit 6 of Green RGB signals. Powered from pin VCCIO2.
51	51	G5	O	Bit 5 of Green RGB signals.

Pin Number		Pin Name	Type	Description
BT815	BT816			
				Powered from pin VCCIO2.
52	52	G4	O	Bit 4 of Green RGB signals. Powered from pin VCCIO2.
53	53	G3	O	Bit 3 of Green RGB signals. Powered from pin VCCIO2.
54	54	G2	O	Bit 2 of Green RGB signals. Powered from pin VCCIO2.
55	55	G1	O	Bit 1 of Green RGB signals. Powered from pin VCCIO2.
56	56	G0	O	Bit 0 of Green RGB signals. Powered from pin VCCIO2.
57	57	VCC1V2	P	1.2V digital core supply. Connect to VOUT1V2 pin.
58	58	R7	O	Bit 7 of Red RGB signals. Powered from pin VCCIO2.
59	59	R6	O	Bit 6 of Red RGB signals. Powered from pin VCCIO2.
60	60	R5	O	Bit 5 of Red RGB signals. Powered from pin VCCIO2.
61	61	R4	O	Bit 4 of Red RGB signals. Powered from pin VCCIO2.
62	62	R3	O	Bit 3 of Red RGB signals. Powered from pin VCCIO2.
63	63	R2	O	Bit 2 of Red RGB signals. Powered from pin VCCIO2.
64	64	R1	O	Bit 1 of Red RGB signals Powered from pin VCCIO2
EP	EP	GND	P	Ground. Exposed thermal pad.

Table 3-1 BT815/6 Pin Description
Note:

P : Power or ground

I : Input

O : Output

OD : Open drain output

I/O : Bi-direction Input and Output

AI/O: Analog Input and Output

4 Functional Description

The BT815/6 is a single chip, embedded video controller with the following functional blocks:

- Quad SPI Host Interface
- Quad SPI Flash Interface
- System Clock
- Graphics Engine
- Parallel RGB video interface
- Audio Engine
- Touch-screen support and interface (Resistive = BT816 / Capacitive – BT815)
- Power Management

The functions for each block are briefly described in the following subsections.

4.1 Quad SPI Host Interface

The BT815/6 uses a quad serial peripheral interface (QSPI) to communicate with host microcontrollers and microprocessors.

4.1.1 QSPI Interface

The QSPI slave interface operates up to 30MHz. Only SPI mode 0 is supported. Refer to section 6.4.2 for detailed timing specification. The QSPI can be configured as a SPI slave in SINGLE, DUAL or QUAD channel modes.

By default the SPI slave operates in the SINGLE channel mode with MOSI as input from the master and MISO as output to the master. DUAL and QUAD channel modes can be configured through the SPI slave itself. To change the channel modes, write to register REG_SPI_WIDTH. The table below depicts the setting.

REG_SPI_WIDTH[1:0]	Channel Mode	Data pins	Max bus speed
00	SINGLE – default mode	MISO, MOSI	30 MHz
01	DUAL	MOSI, MISO	30 MHz
10	QUAD	MOSI, MISO, IO2, IO3	30 MHz
11	Reserved	-	-

Table 4-1 QSPI Channel Selection

With DUAL/QUAD channel modes, the SPI data ports are now unidirectional. In these modes, each SPI transaction (signified by CS_N going active low) will begin with the data ports set as inputs.

Hence, for writing to the BT815/6, the protocol will operate as in FT800, with “WR-Command/Addr2, Addr1, Addr0, DataX, DataY, DataZ ...” The write operation is considered complete when CS_N goes inactive high.

For reading from the BT815/6, the protocol will still operate as in FT800, with “RD-Command/Addr2, Addr1, Addr0, Dummy-Byte, DataX, DataY, DataZ”. However as the data ports are now unidirectional, a change of port direction will occur before DataX is clocked out of the BT815/6. Therefore it is important that the firmware controlling the SPI master changes the SPI master data port direction to “input” after transmitting Addr0. The BT815/6 will not change the port direction till it starts to clock out DataX. Hence, the Dummy-Byte cycles will be used as a change-over period when neither the SPI master nor slave will be driving the bus; the data paths thus must have pull-ups/pull-downs. The SPI slave from the BT815/6 will reset all its data ports’ direction to input once CS_N goes inactive high (i.e. at the end of the current SPI master transaction).

The diagram depicts the behaviour of both the SPI master and slave in the master read case.

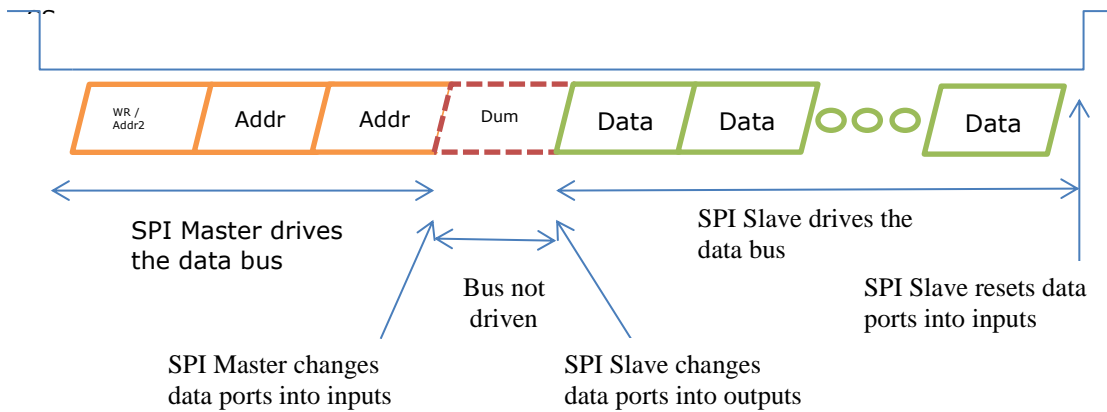

Figure 4-1 SPI Master and Slave in the Master Read Case

In the DUAL channel mode, MISO (MSB) and MOSI are used while in the QUAD channel mode. IO3 (MSB), IO2, MISO and MOSI are used.

Figure 4-2 illustrates a direct connection to a 1.8-3.3V IO MPU/MCU with single or dual SPI interface.

Figure 4-3 illustrates a direct connection to a 1.8-3.3V IO MPU/MCU with Quad SPI interface.

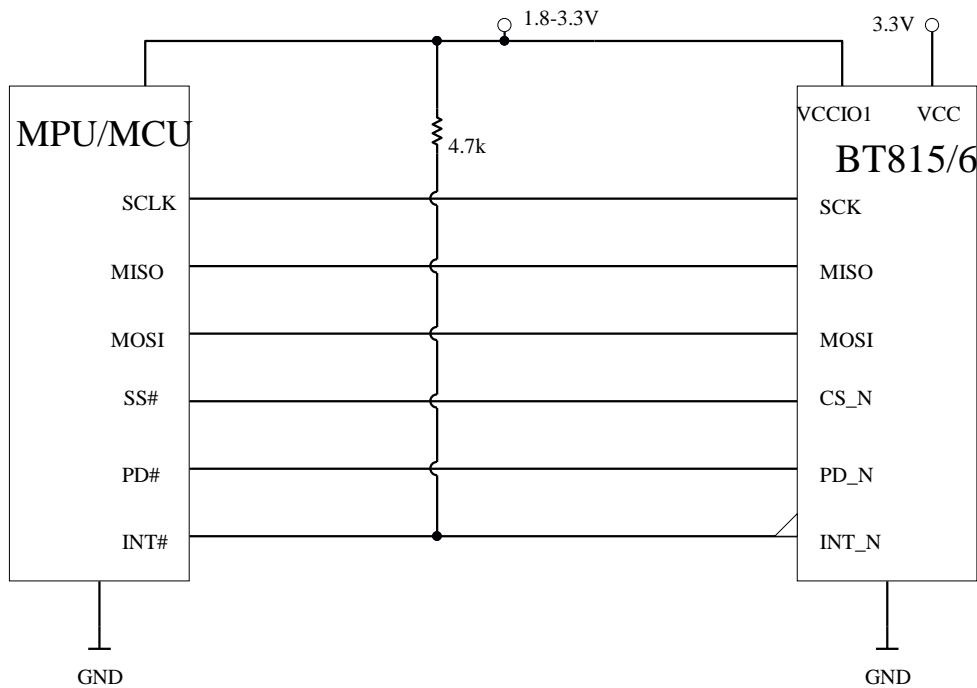

Figure 4-2 Single/Dual SPI Interface connection

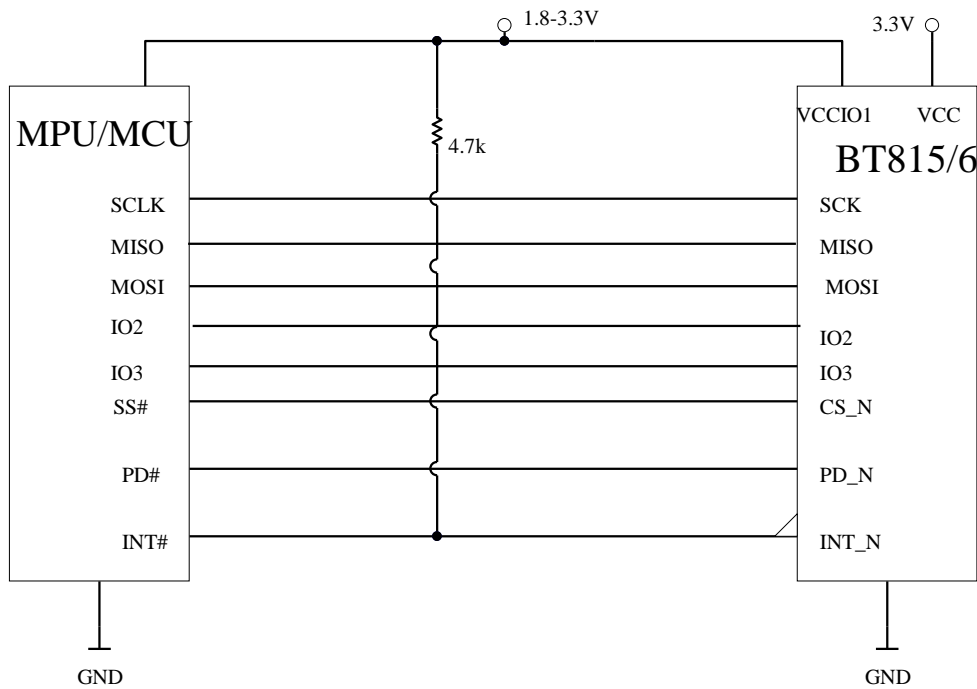

Figure 4-3 Quad SPI Interface connection

4.1.2 Serial Data Protocol

The BT815/6 appears to the host MPU/MCU as a memory-mapped SPI device. The host communicates with the BT815/6 using reads and writes to a large (4 megabyte) address space. Within this address space are dedicated areas for graphics, audio and touch control. Refer to section 5 for the detailed memory map.

The host reads and writes the BT815/6 address space using SPI transactions. These transactions are memory read, memory write and command write. Serial data is sent by the most significant bit first. Each transaction starts with CS_N goes low, and ends when CS_N goes high. There's no limit on data length within one transaction, as long as the memory address is continuous.

4.1.3 Host Memory Read

For SPI memory read transactions, the host sends two zero bits, followed by the 22-bit address. This is followed by a dummy byte. After the dummy byte, the BT815/6 responds to each host byte with read data bytes.

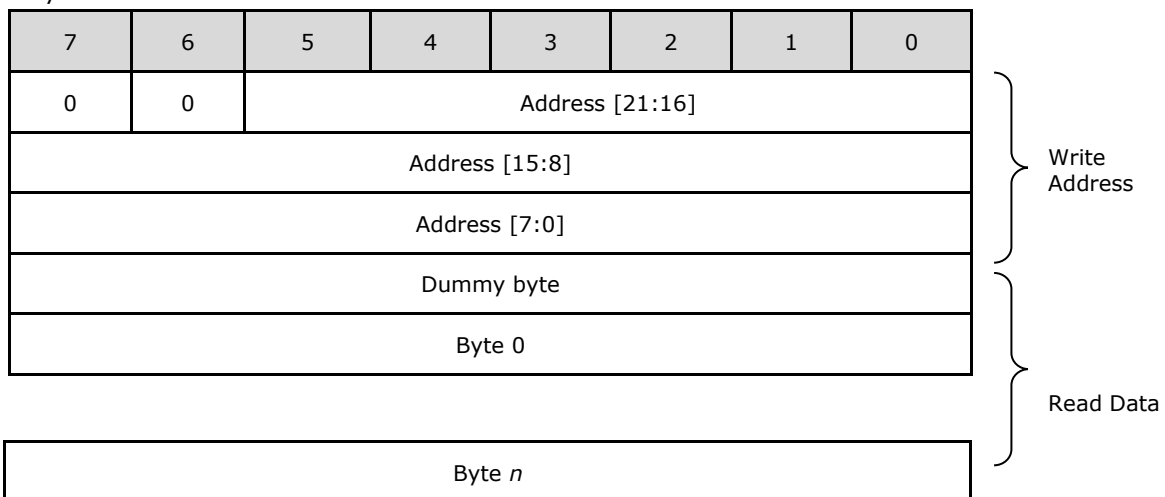

Table 4-2 Host Memory Read Transaction

4.1.4 Host Memory Write

For SPI memory write transactions, the host sends a '1' bit and '0' bit, followed by the 22-bit address. This is followed by the write data.

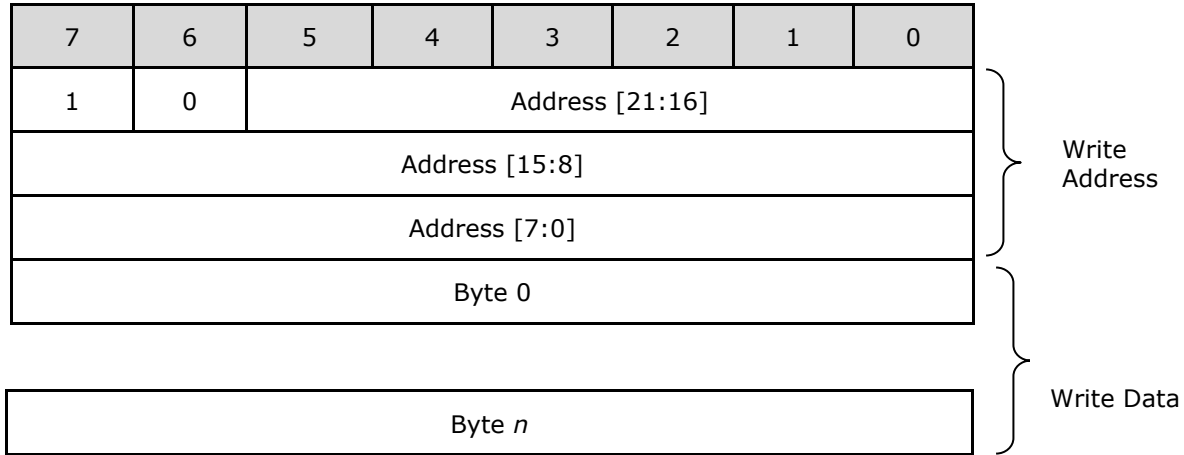

Table 4-3 Host Memory Write Transaction

4.1.5 Host Command

When sending a command, the host transmits a 3 byte command. Table 4-5 Host Command List **Error! Reference source not found.** lists all the host command functions.

For SPI command transactions, the host sends a '0' bit and '1' bit, followed by the 6-bit command code. The 2nd byte can be either 00h, or the parameter of that command. The 3rd byte is fixed at 00h.

All SPI commands except the system reset can only be executed when the SPI is in the Single channel mode. They will be ignored when the SPI is in either Dual or Quad channel mode.

Some commands are used to configure the device and these configurations will be reset upon receiving the SPI PWRDOWN command, except those that configure the pin state during power down. These commands will be sticky unless reconfigured or power-on-reset (POR) occurs.

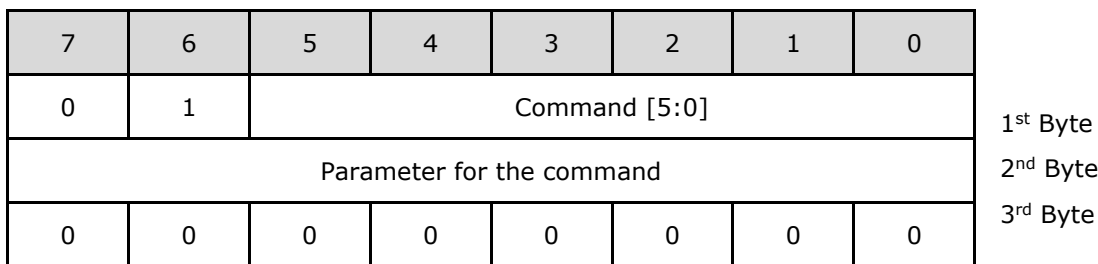

Table 4-4 Host Command Transaction

1st Byte	2nd byte	3rd byte	Command	Description
Power Modes				
00000000b	00000000b	00000000b	00h ACTIVE	Switch from Standby/Sleep/PWRDOWN modes to active mode. Dummy memory read from address 0(read twice) generates ACTIVE command.
01000001b	00000000b	00000000b	41h STANDBY	Put BT815/6 core to standby mode. Clock gate off, PLL and Oscillator remain on (default). ACTIVE command to wake up.

1st Byte	2nd byte	3rd byte	Command	Description														
01000010b	00000000b	00000000b	42h SLEEP	Put BT815/6 core to sleep mode. Clock gate off, PLL and Oscillator off. ACTIVE command to wake up.														
01000011b 01010000b	00000000b	00000000b	43h/50h PWRDOWN	Switch off 1.2V core voltage to the digital core circuits. Clock, PLL and Oscillator off. SPI is alive. ACTIVE command to wake up.														
Clock and Reset																		
01000100b	00000000b	00000000b	44h CLKEXT	Select PLL input from external crystal oscillator or external input clock. No effect if external clock is already selected, otherwise a system reset will be generated														
01001000b	00000000b	00000000b	48h CLKINT	Select PLL input from internal relaxation oscillator (default). No effect if internal clock is already selected, otherwise a system reset will be generated														
01100001b 01100010b	xx	00000000b	61h/62h CLKSEL	<p>Select the system clock frequency. Note that software shall also update the register value for REG_FREQUENCY to align with system clock selected.</p> <p>This command will only be effective when the PLL is stopped (SLEEP mode).</p> <p>For compatibility to FT800/FT801, set Byte2 to 0x00. This will set the PLL clock back to default (60 MHz).</p> <table border="1" style="width: 100%; border-collapse: collapse;"> <tr> <td style="width: 15%;">Byte2 [5:0]</td> <td>sets the clock frequency</td> </tr> <tr> <td>0</td> <td>Set to default clock speed</td> </tr> <tr> <td>1</td> <td>Reserved</td> </tr> <tr> <td>2 to 6</td> <td>2 to 6 times the osc frequency (i.e. 24 to 72MHz with 12MHz oscillator)</td> </tr> <tr> <td>Byte2 [7:6]</td> <td>sets the PLL range</td> </tr> <tr> <td>0</td> <td>When Byte2[5:0] = 0, 2, 3</td> </tr> <tr> <td>1</td> <td>When Byte2[5:0] = 4, 5, 6</td> </tr> </table>	Byte2 [5:0]	sets the clock frequency	0	Set to default clock speed	1	Reserved	2 to 6	2 to 6 times the osc frequency (i.e. 24 to 72MHz with 12MHz oscillator)	Byte2 [7:6]	sets the PLL range	0	When Byte2[5:0] = 0, 2, 3	1	When Byte2[5:0] = 4, 5, 6
Byte2 [5:0]	sets the clock frequency																	
0	Set to default clock speed																	
1	Reserved																	
2 to 6	2 to 6 times the osc frequency (i.e. 24 to 72MHz with 12MHz oscillator)																	
Byte2 [7:6]	sets the PLL range																	
0	When Byte2[5:0] = 0, 2, 3																	
1	When Byte2[5:0] = 4, 5, 6																	
01101000b	00000000b	00000000b	68h RST_PULSE	Send reset pulse to BT815/6 core. The behaviour is the same as POR except that settings done through SPI commands will not be affected														
Configuration																		
01110000b	xx	00000000b	70h PINDRIVE	<p>This will set the drive strength for various pins. For FT800/FT801 compatibility, by default those settings are from the GPIO registers. BT815/6 supports setting the drive strength via SPI command instead.</p> <p>When PINDRIVE for a pin from the SPI command is not updated, the drive strength</p>														

1st Byte	2nd byte	3rd byte	Command	Description																																
				<p>will be determined by its corresponding GPIO register bits, if they exist. If they don't exist, a hard coded setting is used. Please refer to Table 4-21 for default values.</p> <p>When PINDRIVE for a pin from the SPI command is updated, it will override the corresponding setting in the GPIO register bits.</p> <p>Byte2 determines which pin and the setting are to be updated.</p> <p>Byte2[1:0] determine the drive strength.</p> <p>For pins R[7:0]/G[7:0]/B[7:0]/PCLK/DISP/HSYNC/V SYNC/DE/BACKLIGHT:</p> <table border="1"> <thead> <tr> <th>Byte2[1:0]</th> <th>Drive Strength</th> </tr> </thead> <tbody> <tr> <td>0h</td> <td>1.2mA</td> </tr> <tr> <td>1h</td> <td>2.4mA</td> </tr> <tr> <td>2h</td> <td>3.6mA</td> </tr> <tr> <td>3h</td> <td>4.8mA</td> </tr> </tbody> </table> <p>For all other pins:</p> <table border="1"> <thead> <tr> <th>Byte2[1:0]</th> <th>Drive Strength</th> </tr> </thead> <tbody> <tr> <td>0h</td> <td>5mA</td> </tr> <tr> <td>1h</td> <td>10mA</td> </tr> <tr> <td>2h</td> <td>15mA</td> </tr> <tr> <td>3h</td> <td>20mA</td> </tr> </tbody> </table> <p>Byte2[7:2] determine which pin/pin group to set:</p> <table border="1"> <thead> <tr> <th>Byte2 [7:2]</th> <th>Pin / Pin Group</th> </tr> </thead> <tbody> <tr> <td>00h</td> <td>GPIO 0</td> </tr> <tr> <td>01h</td> <td>GPIO 1</td> </tr> <tr> <td>02h</td> <td>GPIO 2</td> </tr> <tr> <td>03h</td> <td>GPIO 3</td> </tr> <tr> <td>04-07h</td> <td>Reserved</td> </tr> </tbody> </table>	Byte2[1:0]	Drive Strength	0h	1.2mA	1h	2.4mA	2h	3.6mA	3h	4.8mA	Byte2[1:0]	Drive Strength	0h	5mA	1h	10mA	2h	15mA	3h	20mA	Byte2 [7:2]	Pin / Pin Group	00h	GPIO 0	01h	GPIO 1	02h	GPIO 2	03h	GPIO 3	04-07h	Reserved
Byte2[1:0]	Drive Strength																																			
0h	1.2mA																																			
1h	2.4mA																																			
2h	3.6mA																																			
3h	4.8mA																																			
Byte2[1:0]	Drive Strength																																			
0h	5mA																																			
1h	10mA																																			
2h	15mA																																			
3h	20mA																																			
Byte2 [7:2]	Pin / Pin Group																																			
00h	GPIO 0																																			
01h	GPIO 1																																			
02h	GPIO 2																																			
03h	GPIO 3																																			
04-07h	Reserved																																			

1st Byte	2nd byte	3rd byte	Command	Description																																						
				<table border="1"> <tr><td>08h</td><td>DISP</td></tr> <tr><td>09h</td><td>DE</td></tr> <tr><td>0Ah</td><td>VSYNC / HSYNC</td></tr> <tr><td>0Bh</td><td>PCLK</td></tr> <tr><td>0Ch</td><td>BACKLIGHT</td></tr> <tr><td>0Dh</td><td>R[7:0], G[7:0], B[7:0]</td></tr> <tr><td>0Eh</td><td>AUDIO_L</td></tr> <tr><td>0Fh</td><td>INT_N</td></tr> <tr><td>10h</td><td>CTP_RST_N</td></tr> <tr><td>11h</td><td>CTP_SCL</td></tr> <tr><td>12h</td><td>CTP_SDA</td></tr> <tr><td>13h</td><td>SPI MISO/MOSI/IO2/IO3</td></tr> <tr><td>14h</td><td>SPIM_SCLK</td></tr> <tr><td>15h</td><td>SPIM_SS_N</td></tr> <tr><td>16h</td><td>SPIM_MISO</td></tr> <tr><td>17h</td><td>SPIM_MOSI</td></tr> <tr><td>18h</td><td>SPIM_IO2</td></tr> <tr><td>19h</td><td>SPIM_IO3</td></tr> <tr><td>Others</td><td>Reserved</td></tr> </table> <p>Note: GPIO0 shares the same pin as SPI IO2 and GPIO1 with SPI IO3. When SPI is set in Quad mode, IO2 and IO3 will inherit the drive strength set in GROUP 13h; otherwise GPIO0 and GPIO1 will inherit the drive strength from GROUP 00h and 01h respectively.</p>	08h	DISP	09h	DE	0Ah	VSYNC / HSYNC	0Bh	PCLK	0Ch	BACKLIGHT	0Dh	R[7:0], G[7:0], B[7:0]	0Eh	AUDIO_L	0Fh	INT_N	10h	CTP_RST_N	11h	CTP_SCL	12h	CTP_SDA	13h	SPI MISO/MOSI/IO2/IO3	14h	SPIM_SCLK	15h	SPIM_SS_N	16h	SPIM_MISO	17h	SPIM_MOSI	18h	SPIM_IO2	19h	SPIM_IO3	Others	Reserved
08h	DISP																																									
09h	DE																																									
0Ah	VSYNC / HSYNC																																									
0Bh	PCLK																																									
0Ch	BACKLIGHT																																									
0Dh	R[7:0], G[7:0], B[7:0]																																									
0Eh	AUDIO_L																																									
0Fh	INT_N																																									
10h	CTP_RST_N																																									
11h	CTP_SCL																																									
12h	CTP_SDA																																									
13h	SPI MISO/MOSI/IO2/IO3																																									
14h	SPIM_SCLK																																									
15h	SPIM_SS_N																																									
16h	SPIM_MISO																																									
17h	SPIM_MOSI																																									
18h	SPIM_IO2																																									
19h	SPIM_IO3																																									
Others	Reserved																																									
01110001b	xx	00000000b	71h PIN_PD_STA TE	<p>During power down, all output and in/out pins will not be driven. Please refer to Table 4-21 for their default power down state.</p> <p>These settings will only be effective during power down and will not affect normal operations. Also note that these configuration bits are sticky and, unlike other configuration bits, will not reset to default values upon exiting power down. Only POR will reset them.</p>																																						

1st Byte	2nd byte	3rd byte	Command	Description										
				Byte2 determines which pin and the setting are to be updated. Byte2[1:0] determine the pin state. <table border="1" data-bbox="885 403 1404 728"> <thead> <tr> <th>Byte2 [1:0]</th> <th>Pin Setting</th> </tr> </thead> <tbody> <tr> <td>0h</td> <td>Float</td> </tr> <tr> <td>1h</td> <td>Pull-Down</td> </tr> <tr> <td>2h</td> <td>Pull-Up</td> </tr> <tr> <td>3h</td> <td>Reserved</td> </tr> </tbody> </table> Byte2[7:2] determine which pin/pin group to set. Please refer to the table in command PINDRIVE entry.	Byte2 [1:0]	Pin Setting	0h	Float	1h	Pull-Down	2h	Pull-Up	3h	Reserved
Byte2 [1:0]	Pin Setting													
0h	Float													
1h	Pull-Down													
2h	Pull-Up													
3h	Reserved													

Table 4-5 Host Command List

Note: Any command code not specified is reserved and should not be used by the software

4.1.6 Interrupts

The interrupt output pin is enabled by REG_INT_EN. When REG_INT_EN is 0, INT_N is tri-state (pulled to high by external pull-up resistor). When REG_INT_EN is 1, INT_N is driven low when any of the interrupt flags in REG_INT_FLAGS are high, after masking with REG_INT_MASK. Writing a '1' in any bit of REG_INT_MASK will enable the corresponding interrupt. Each bit in REG_INT_FLAGS is set by a corresponding interrupt source. REG_INT_FLAGS is readable by the host at any time, and clears when read.

The INT_N pin is open-drain (OD) output by default. It can be configured to push-pull output by register REG_GPIOX.

Bit	7	6	5	4
Interrupt Sources	CONVCOMPLETE	CMDFLAG	CMDEMPTY	PLAYBACK
Conditions	Touch-screen conversions completed	Command FIFO flag	Command FIFO empty	Audio playback ended
Bit	3	2	1	0
Interrupt Sources	SOUND	TAG	TOUCH	SWAP
Conditions	Sound effect ended	Touch-screen tag value change	touch detected	Display list swap occurred

Table 4-6 Interrupt Flags bit assignment

4.2 System Clock

4.2.1 Clock Source

The BT815/6 can be configured to use any of the three clock sources for system clock:

- Internal relaxation oscillator clock (default)
- External 12MHz crystal
- External 12MHz square wave clock

Figure 4-4, Figure 4-5 and Figure 4-6 show the pin connections for these clock options.

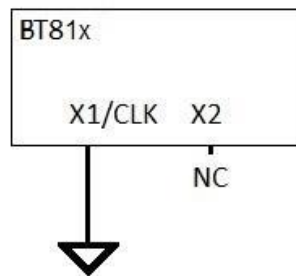

Figure 4-4 Internal relaxation oscillator connection

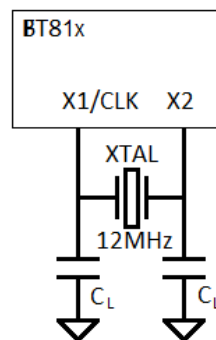

Figure 4-5 Crystal Oscillator Connection

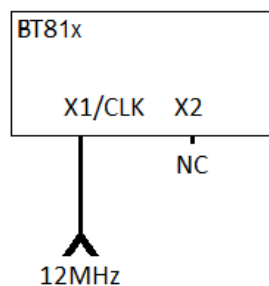

Figure 4-6 External Clock Input

4.2.2 Phase Locked Loop

The internal PLL takes an input clock from the oscillator, and generates clocks to all internal circuits, including the graphics engine, audio engine and touch engine.

4.2.3 Clock Enable

At power-on the BT815/6 is in sleep mode. The internal relaxation oscillator is selected for the PLL clock source. The system clock will be enabled when the following step is executed:

- Host sends an "ACTIVE" command

If the application chooses to use the external clock source (12MHz crystal or clock), the following steps shall be executed:

- Host sends a "CLKEXT" command
- Host sends an "ACTIVE" command

4.2.4 Clock Frequency

By default the system clock is running at 60MHz when the input clock is 12MHz. The host is allowed to switch the system clock to other frequencies (72MHz, 48MHz, 36MHz, and 24MHz) by the host command "CLKSEL". The clock switching command shall be sent in SLEEP mode only.

After the chip is put into Active mode, software shall update the REG_FREQUENCY value to align with the chosen system clock frequency by CLKSEL command, if the default 60MHz is changed.

When using the internal relaxation oscillator, its clock frequency is trimmed to be 12MHz at factory. Software is allowed to change the frequency to a lower value by programming the register REG_TRIM. Note that software shall not change the internal oscillator frequency to be higher than 12MHz.

4.3 Graphics Engine

4.3.1 Introduction

The graphics engine executes the display list once for every horizontal line. It executes the primitive objects in the display list and constructs the display line buffer. The horizontal pixel content in the line buffer is updated if the object is visible at the horizontal line.

Main features of the graphics engine are:

- The primitive objects supported by the graphics processor are: lines, points, rectangles, bitmaps (comprehensive set of formats), text display, plotting bar graph, edge strips, and line strips, etc.
- Operations such as stencil test, alpha blending and masking are useful for creating a rich set of effects such as shadows, transitions, reveals, fades and wipes.
- Anti-aliasing of the primitive objects (except bitmaps) gives a smoothing effect to the viewer.
- Bitmap transformations enable operations such as translate, scale and rotate.
- Display pixels are plotted with 1/16th pixel precision.
- Four levels of graphics states
- Tag buffer detection

The graphics engine also supports customized built-in widgets and functionalities such as ASTC decode, jpeg decode, screen saver, calibration etc. The graphics engine interprets commands from the MPU host via a 4 Kbyte FIFO in the BT815/6 memory at RAM_CMD. The MPU/MCU writes commands into the FIFO, and the graphics engine reads and executes the commands. The MPU/MCU updates the register REG_CMD_WRITE to indicate that there are new commands in the FIFO, and the graphics engine updates REG_CMD_READ after commands have been executed.

Main features supported are:

- Drawing of widgets such as buttons, clock, keys, gauges, text displays, progress bars, sliders, toggle switches, dials, gradients, etc.
- JPEG and motion-JPEG decode
- Inflate functionality (zlib inflate is supported)
- Timed interrupt (generate an interrupt to the host processor after a specified number of milliseconds)

- In-built animated functionalities such as displaying logo, calibration, spinner, screen saver and sketch
- Snapshot feature to capture the current graphics display

For a complete list of graphics engine display commands and widgets refer to [BT81X Series Programming Guide](#), Chapter 4.

4.3.2 ASTC

ASTC stands for Adaptive Scalable Texture Compression, an open standard developed by ARM for use in mobile GPUs.

ASTC is a block-based lossy compression format. The compressed image is divided into a number of blocks of uniform size, which makes it possible to quickly determine which block a given texel resides in. Each block has a fixed memory footprint of 128 bits, but these bits can represent varying numbers of texels (the block footprint).

Block footprint sizes are not confined to powers-of-two, and are also not confined to be square. For 2D formats the block dimensions range from 4 to 12 texels.

Using ASTC for the large ROM fonts can save considerable space. Encoding the four largest fonts in ASTC 8x8 formats gives no noticeable loss in quality and reduces the ROM size from 1 MByte to about 640 Kbytes.

4.3.3 ROM and RAM Fonts

The BT815/6 has built in ROM character bitmaps as font metrics. The graphics engine can use these metrics when drawing text fonts. There are a total of 19 ROM fonts, numbered with font handle 16-34. Fonts 31-34 are large ROM fonts encoded in ASTC 8x8 format. The user can define and load customized font metrics into RAM_G or external flash, making it possible to support a full range of Unicode characters with UTF-8 coding points.

Each ROM font metric block has a 148 byte font table which defines the parameters of the font and the pointer of font image. The font table format is shown in Table 4-7.

Address Offset	Size(byte)	Parameter Description
0	128	width of each font character, in pixels
128	4	font bitmap format, for example L1, L4 or L8
132	4	font line stride, in bytes
136	4	font width, in pixels
140	4	font height, in pixels
144	4	pointer to font image data in memory

Table 4-7 Font Table Format

The ROM fonts are stored in the memory space ROM_FONT. The ROM font table is also stored in the ROM. The starting address of the ROM font table for font index 16 is stored at ROM_FONT_ADDR, with other font tables following. The ROM font table and individual character width (in pixel) are listed in Table 4-8, Table 4-9 and Table 4-10. Font index 16, 18 and 20-31 are for basic ASCII characters (code 0-127), while font index 17 and 19 are for Extended ASCII characters (code 128-255). The character width for font index 16 through 19 is fixed at 8 pixels for any of the ASCII characters.

Font Index	16	17	18	19	20	21	22	23	24	25	26	27	28	29	30	31	32	33	34
Font format	L1	L1	L1	L1	L1	L1	L1	L1	L1	L1	L4	L4	L4	L4	L4	L4	L4	L4	L4
Line stride	1	1	1	1	2	2	2	3	3	4	7	8	9	11	14	18	23	30	39
Font width (max)	8	8	8	8	11	13	17	8	5	4	3	5	9	11	8	7	9	6	8
Font height	8	8	1	1	1	1	2	2	2	3	1	2	2	2	3	4	6	8	1

			6	6	3	7	0	2	9	8	6	0	5	8	6	9	3	3	0	8
--	--	--	---	---	---	---	---	---	---	---	---	---	---	---	---	---	---	---	---	---

Table 4-8 ROM Font Table

Font Index =>	16/18	2				2				3				3						
		0	1	2	3	4	5	6	7	8	9	0	1	2	3	4				
0	NULL	8	0	0	0	0	0	0	0	0	0	0	0	0	0	0	0	0	0	0
1	SOH	8	0	0	0	0	0	0	0	0	0	0	0	0	0	0	0	0	0	0
2	STX	8	0	0	0	0	0	0	0	0	0	0	0	0	0	0	0	0	0	0
3	ETX	8	0	0	0	0	0	0	0	0	0	0	0	0	0	0	0	0	0	0
4	EOT	8	0	0	0	0	0	0	0	0	0	0	0	0	0	0	0	0	0	0
5	ENQ	8	0	0	0	0	0	0	0	0	0	0	0	0	0	0	0	0	0	0
6	ACK	8	0	0	0	0	0	0	0	0	0	0	0	0	0	0	0	0	0	0
7	BEL	8	0	0	0	0	0	0	0	0	0	0	0	0	0	0	0	0	0	0
8	BS	8	0	0	0	0	0	0	0	0	0	0	0	0	0	0	0	0	0	0
9	HT	8	0	0	0	0	0	0	0	0	0	0	0	0	0	0	0	0	0	0
10	LF	8	0	0	0	0	0	0	0	0	0	0	0	0	0	0	0	0	0	0
11	VT	8	0	0	0	0	0	0	0	0	0	0	0	0	0	0	0	0	0	0
12	FF	8	0	0	0	0	0	0	0	0	0	0	0	0	0	0	0	0	0	0
13	CR	8	0	0	0	0	0	0	0	0	0	0	0	0	0	0	0	0	0	0
14	SO	8	0	0	0	0	0	0	0	0	0	0	0	0	0	0	0	0	0	0
15	SI	8	0	0	0	0	0	0	0	0	0	0	0	0	0	0	0	0	0	0
16	DLE	8	0	0	0	0	0	0	0	0	0	0	0	0	0	0	0	0	0	0
17	DC1	8	0	0	0	0	0	0	0	0	0	0	0	0	0	0	0	0	0	0
18	DC2	8	0	0	0	0	0	0	0	0	0	0	0	0	0	0	0	0	0	0
19	DC3	8	0	0	0	0	0	0	0	0	0	0	0	0	0	0	0	0	0	0
20	DC4	8	0	0	0	0	0	0	0	0	0	0	0	0	0	0	0	0	0	0
21	NAK	8	0	0	0	0	0	0	0	0	0	0	0	0	0	0	0	0	0	0
22	SYN	8	0	0	0	0	0	0	0	0	0	0	0	0	0	0	0	0	0	0
23	ETB	8	0	0	0	0	0	0	0	0	0	0	0	0	0	0	0	0	0	0
24	CAN	8	0	0	0	0	0	0	0	0	0	0	0	0	0	0	0	0	0	0
25	EM	8	0	0	0	0	0	0	0	0	0	0	0	0	0	0	0	0	0	0
26	SUB	8	0	0	0	0	0	0	0	0	0	0	0	0	0	0	0	0	0	0
27	ESC	8	0	0	0	0	0	0	0	0	0	0	0	0	0	0	0	0	0	0
28	FS	8	0	0	0	0	0	0	0	0	0	0	0	0	0	0	0	0	0	0
29	GS	8	0	0	0	0	0	0	0	0	0	0	0	0	0	0	0	0	0	0
30	RS	8	0	0	0	0	0	0	0	0	0	0	0	0	0	0	0	0	0	0
31	US	8	0	0	0	0	0	0	0	0	0	0	0	0	0	0	0	0	0	0
32	space	8	3	4	5	5	6	9	3	4	5	6	8	10	13	18	23			
33	!	8	3	4	5	6	6	9	3	4	6	6	9	11	15	19	25			
34	"	8	4	5	6	5	8	12	5	6	7	8	12	15	19	25	33			
35	#	8	6	8	9	10	14	19	10	11	14	15	19	26	33	44	57			
36	\$	8	6	8	9	10	13	18	8	10	11	15	18	25	31	41	54			
37	%	8	9	12	14	16	22	29	11	13	16	17	23	31	40	52	68			
38	&	8	8	10	11	13	17	22	9	11	14	15	19	26	34	44	57			
39	'	8	2	3	3	3	6	6	3	4	4	5	7	10	11	15	20			
40	(8	4	5	6	6	8	11	5	6	7	9	11	15	18	24	31			
41)	8	4	5	6	6	8	11	5	6	8	8	10	14	18	24	31			
42	*	8	4	7	6	7	10	13	7	8	10	11	14	18	24	31	40			
43	+	8	6	9	10	10	14	19	9	10	12	14	17	24	30	41	52			
44	,	8	3	3	4	5	6	9	3	4	4	5	7	9	12	16	20			
45	-	8	4	4	5	6	8	11	6	7	10	11	15	18	24	32	41			
46	.	8	3	3	4	5	6	9	3	4	6	7	8	11	14	19	24			
47	/	8	3	4	5	5	7	9	6	7	9	10	13	17	22	29	38			
48	0	8	6	8	9	10	13	18	8	10	12	14	17	24	30	40	52			
49	1	8	6	8	9	10	13	18	8	10	12	14	17	24	30	40	52			

ASCII Character width in pixels

Font Index	=>	16/18	20	21	22	23	24	25	26	27	28	29	30	31	32	33	34
50	2	8	6	8	9	10	13	18	8	10	12	14	17	24	30	40	52
51	3	8	6	8	9	10	13	18	8	10	12	14	17	24	30	40	52
52	4	8	6	8	9	10	13	18	8	10	12	14	17	24	30	40	52
53	5	8	6	8	9	10	13	18	8	10	12	14	17	24	30	40	52
54	6	8	6	8	9	10	13	18	8	10	12	14	17	24	30	40	52
55	7	8	6	8	9	10	13	18	8	10	12	14	17	24	30	40	52
56	8	8	6	8	9	10	13	18	8	10	12	14	17	24	30	40	52
57	9	8	6	8	9	10	13	18	8	10	12	14	17	24	30	40	52
58	:	8	3	3	4	5	6	9	3	4	6	6	7	10	13	18	23
59	;	8	3	4	4	5	6	9	3	4	6	6	8	10	14	18	23
60	<	8	6	8	10	10	15	19	8	9	11	12	16	21	28	36	46
61	=	8	5	9	10	11	15	19	8	9	13	14	18	23	30	40	52
62	>	8	6	8	10	10	15	19	8	9	11	13	16	22	29	37	48
63	?	8	6	8	9	10	12	18	7	9	10	12	15	20	26	34	44
64	@	8	11	13	17	18	25	34	13	15	19	21	28	37	49	63	82
65	A	8	7	9	11	13	17	22	9	11	13	15	20	27	34	45	58
66	B	8	7	9	11	13	17	22	9	10	14	15	19	27	34	45	58
67	C	8	8	10	12	14	18	24	9	11	13	15	20	26	34	45	58
68	D	8	8	10	12	14	18	24	9	11	14	17	22	28	36	48	63
69	E	8	7	9	11	13	16	22	7	9	12	13	16	23	29	39	50
70	F	8	6	8	10	12	14	20	7	9	12	13	17	22	29	39	50
71	G	8	8	11	13	15	19	25	9	11	14	16	22	28	37	48	62
72	H	8	8	10	12	14	18	24	9	11	15	17	23	29	37	50	65
73	I	8	3	4	4	6	8	9	4	5	6	7	9	12	15	20	26
74	J	8	5	7	8	10	13	16	8	9	12	13	17	23	30	40	50
75	K	8	7	9	11	13	18	22	9	11	14	16	19	26	34	45	58
76	L	8	6	8	9	11	14	18	7	9	12	13	17	22	29	39	51
77	M	8	9	12	13	16	21	27	11	14	19	21	26	35	46	62	79
78	N	8	8	10	12	14	18	24	9	11	15	17	23	29	37	50	65
79	O	8	8	11	13	15	18	25	10	12	14	16	22	28	37	49	63
80	P	8	7	9	11	13	16	22	9	10	14	15	19	26	34	45	58
81	Q	8	8	11	13	15	18	26	10	12	14	17	22	29	38	50	64
82	R	8	7	10	12	14	17	24	9	11	13	15	19	27	33	45	58
83	S	8	7	9	11	13	16	22	9	11	12	14	20	26	33	43	56
84	T	8	5	9	10	12	16	20	10	12	14	15	19	26	32	42	56
85	U	8	8	10	12	14	18	24	9	11	13	17	21	28	37	48	62
86	V	8	7	9	11	13	17	22	9	11	14	15	20	27	34	45	58
87	W	8	9	13	15	18	22	31	12	15	18	21	27	36	46	61	79
88	X	8	7	9	11	13	17	22	9	11	13	15	20	27	34	45	58
89	Y	8	7	9	11	13	16	22	9	10	14	15	19	26	34	45	58
90	Z	8	7	9	10	12	15	20	9	11	13	14	18	25	32	42	55
91	[8	3	4	5	5	7	9	4	5	6	7	9	12	15	19	25
92	\	8	3	4	5	5	7	9	6	7	9	10	13	18	22	29	38
93]	8	3	4	5	5	7	9	4	5	7	7	9	12	15	19	25
94	^	8	6	7	8	9	12	16	6	7	9	10	13	18	23	30	38
95	_	8	6	8	9	11	14	18	8	10	11	13	16	21	26	34	43
96	`	8	3	5	6	4	7	11	4	5	7	8	10	13	17	22	29
97	a	8	5	8	9	11	13	18	8	9	11	13	17	23	30	39	50
98	b	8	6	7	9	11	14	18	8	9	11	14	17	24	31	40	52
99	c	8	5	7	8	10	12	16	8	9	11	12	16	22	28	37	48
100	d	8	6	8	9	11	14	18	8	10	12	14	17	24	31	40	52
101	e	8	5	8	9	10	13	18	8	9	11	12	16	22	29	37	48
102	f	8	4	4	5	6	8	9	6	7	8	10	12	15	19	25	31
103	g	8	6	8	9	11	14	18	8	10	11	14	18	24	31	41	52

Font Index =>	16/18	20	21	22	23	24	25	26	27	28	29	30	31	32	33	34	
104	h	8	6	8	9	10	13	18	8	9	11	14	17	24	31	41	52
105	i	8	2	3	3	4	6	7	3	4	6	6	7	10	13	18	23
106	j	8	2	3	4	4	6	7	3	4	6	6	8	11	14	18	23
107	k	8	5	7	8	9	12	16	7	9	11	13	16	22	28	36	47
108	l	8	2	3	3	4	6	7	3	4	6	6	7	10	13	18	23
109	m	8	8	11	14	16	20	27	11	15	18	21	27	36	47	63	80
110	n	8	6	8	9	10	14	18	8	9	11	14	17	24	31	41	52
111	o	8	6	8	9	11	13	18	8	10	12	13	17	24	31	40	52
112	p	8	6	8	9	11	14	18	8	9	11	14	17	24	31	40	51
113	q	8	6	8	9	11	14	18	8	10	12	13	17	24	31	40	52
114	r	8	4	5	5	6	9	11	5	6	7	9	11	15	19	25	32
115	s	8	5	7	8	9	12	16	7	9	11	12	17	22	29	38	48
116	t	8	4	4	5	6	8	9	6	7	8	9	11	14	17	23	29
117	u	8	5	7	9	10	14	18	8	9	12	14	17	24	31	41	52
118	v	8	6	7	8	10	13	16	7	9	11	12	16	21	27	36	46
119	w	8	8	10	12	14	18	23	11	13	16	18	23	32	41	54	70
120	x	8	6	7	8	10	12	16	7	9	11	12	16	21	27	36	46
121	y	8	5	7	8	10	13	16	7	9	11	12	16	21	27	36	46
122	z	8	5	7	8	9	12	16	8	9	11	12	15	22	27	36	46
123	{	8	3	5	6	6	8	11	5	6	8	8	11	15	18	24	31
124		8	3	3	4	5	6	9	3	4	5	6	7	10	14	18	23
125	}	8	3	5	6	6	8	11	5	6	7	9	10	15	18	24	31
126	~	8	7	8	10	10	14	19	10	11	14	15	21	29	36	47	63
127	DEL	8	0	0	0	0	0	0	3	4	5	6	5	10	13	18	23

Table 4-9 ROM font ASCII character width in pixels

Decimal	Symbol	Decimal	Symbol	Decimal	Symbol	Decimal	Symbol	Decimal	Symbol	Decimal	Symbol	Decimal	Symbol	Decimal	Symbol
128	ç	144	É	160	á	176	☼	192	└	208	┘	224	α	240	≡
129	ü	145	æ	161	í	177	☼	193	┘	209	┘	225	β	241	±
130	é	146	Æ	162	ó	178	☼	194	┘	210	┘	226	γ	242	≥
131	â	147	ô	163	ú	179		195	┘	211	┘	227	π	243	≤
132	ä	148	ö	164	ñ	180	┘	196	—	212	┘	228	Σ	244	∫
133	à	149	ò	165	Ñ	181	┘	197	+	213	┘	229	σ	245	∫
134	â	150	û	166	ª	182	┘	198	┘	214	┘	230	μ	246	÷
135	ç	151	ù	167	º	183	┘	199	┘	215	┘	231	τ	247	≈
136	ê	152	ÿ	168	¿	184	┘	200	┘	216	┘	232	φ	248	°
137	ë	153	ö	169	¬	185	┘	201	┘	217	┘	233	θ	249	•
138	è	154	Ü	170	¬	186		202	┘	218	┘	234	Ω	250	·
139	ï	155	¢	171	½	187	┘	203	┘	219	■	235	δ	251	√
140	î	156	£	172	¼	188	┘	204	┘	220	■	236	ω	252	ⁿ
141	ì	157	¥	173	¡	189	┘	205	=	221	■	237	φ	253	²
142	Ä	158	₣	174	«	190	┘	206	┘	222	■	238	ε	254	■
143	Å	159	₣	175	»	191	┘	207	┘	223	■	239	π	255	nbsp

Table 4-10 ROM Font Extended ASCII Characters

Note 1: Font 17 and 19 are extended ASCII characters, with width fixed at 8 pixels for all characters.

Note 2: All fonts included in the BT815/6 ROM are widely available to the market-place for general usage. See section nine for specific copyright data and links to the corresponding license agreements.

4.4 SPI NOR Flash Interface

The BT815/6 implements a SPI master to connect to external SPI NOR Flash. Graphics assets such as Unicode fonts and images can be stored in the flash memory. The BT815/6 graphics engine can fetch these graphics assets directly without going through external host MCU, thus significantly offloading the host MCU from feeding display contents.

The BT815/6 supports various NOR flash memory device from different vendors such as Macronix, Winbond, Micron, ISSI and Gigadevice. The interface will work at system clock speed (up to 72MHz) at 4 bit mode.

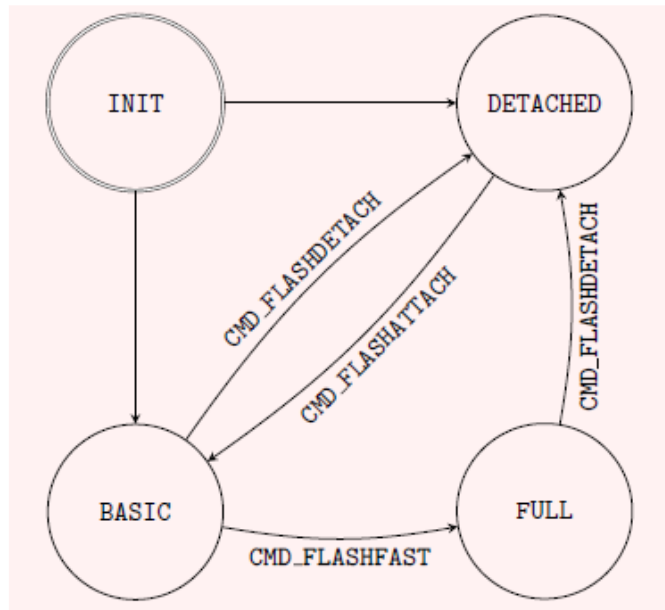

Figure 4-7 Flash Interface States

The register REG_FLASH_STATE indicates the state of the flash subsystem. At boot the flash state is FLASH_STATE_INIT. After detection has completed flash is in state FLASH_STATE_DETACHED or FLASH_STATE_BASIC, depending on whether an attached flash device was detected. If no device is detected, then all SPI output signals are driven low.

When the host MCU calls CMD_FLASHFAST, the flash system attempts to go to full-speed mode, setting state to FLASH_STATE_FULL.

At any time the user can call CMD_FLASHDETACH in order to disable flash communications. In the detached state, commands CMD_FLASHSPIDESEL, CMD_FLASHSPITX and CMD_FLASHSPIRX can be used to control the SPI bus.

If detached, the host MCU can call CMD_FLASHATTACH to re-establish communication with the flash device.

Direct rendering of bitmaps from flash is only possible in FLASH_STATE_FULL. After modifying the contents of flash, the MCU should clear the on-chip bitmap cache by calling CMD_CLEARCACHE.

4.5 Parallel RGB Interface

The RGB parallel interface consists of 29 signals - DISP, PCLK, VSYNC, HSYNC, DE, 8 signals each for R, G and B.

A set of RGB registers configure the LCD operation and timing parameters.

REG_PCLK is the PCLK divisor. The default value is 0, which means the PCLK output is disabled. When REG_PCLK is none 0 (1-1023), the PCLK frequency can be calculated as:

$$\text{PCLK frequency} = \text{System Clock frequency} / \text{REG_PCLK}$$

The BT815/6 system clock frequency is programmable. Some of the possible PCLK frequencies that BT815/6 supports are listed in Table 4-11.

REG_PCLK	System Clock Frequency (MHz)				
	72	60(default)	48	36	24
2	36	30	24	18	12
3	24	20	16	12	8.0
4	18	15	12	9.0	6.0
5	14.5	12	9.6	7.2	4.8
6	12	10	8.0	6.0	4.0
7	10.3	8.6	6.9	5.1	3.4
8	9	7.5	6.0	4.5	3.0
9	8	6.7	5.3	4.0	2.7
10	7.2	6.0	4.8	3.6	2.4

Table 4-11 RGB PCLK Frequency

REG_PCLK_POL defines the clock polarity, with 0 for positive active clock edge, and 1 for negative clock edge.

REG_CSPREAD controls the transition of RGB signals with respect to the PCLK active clock edge. When REG_CSPREAD=0, R[7:0], G[7:0] and B[7:0] signals change following the active edge of PCLK. When REG_CSPREAD=1, R[7:0] changes a PCLK clock early and B[7:0] a PCLK clock later, which helps reduce the switching noise.

REG_DITHER enables colour dither. This option improves the half-tone appearance on displays. Internally, the graphics engine computes the colour values at an 8 bit precision; however, the LCD colour at a lower precision is sufficient.

REG_OUTBITS gives the bit width of each colour channel; the default is 8/8/8 bits for each R/G/B colour. A lower value means fewer bits are output for each channel allowing dithering on lower precision LCD displays.

REG_SWIZZLE controls the arrangement of the output colour pins, to help the PCB route different LCD panel arrangements. Bit 0 of the register causes the order of bits in each colour channel to be reversed. Bits 1-3 control the RGB order. Setting Bit 1 causes R and B channels to be swapped. Setting Bit 3 allows rotation to be enabled. If Bit 3 is set, then (R, G, B) is rotated right if bit 2 is one, or left if bit 2 is zero.

REG_SWIZZLE				RGB PINS		
b3	b2	b1	b0	R7, R6, R5, R4, R3, R2, R1, R0	G7, G6, G5, G4, G3, G2, G1, G0	B7, B6, B5, B4, B3, B2, B1, B0
0	X	0	0	R[7:0]	G[7:0]	B[7:0]
0	X	0	1	R[0:7]	G[0:7]	B[0:7]
0	X	1	0	B[7:0]	G[7:0]	R[7:0]
0	X	1	1	B[0:7]	G[0:7]	R[0:7]
1	0	0	0	B[7:0]	R[7:0]	G[7:0]

1	0	0	1	B[0:7]	R[0:7]	G[0:7]
1	0	1	0	G[7:0]	R[7:0]	B[7:0]
1	0	1	1	G[0:7]	R[0:7]	B[0:7]
1	1	0	0	G[7:0]	B[7:0]	R[7:0]
1	1	0	1	G[0:7]	B[0:7]	R[0:7]
1	1	1	0	R[7:0]	B[7:0]	G[7:0]
1	1	1	1	R[0:7]	B[0:7]	G[0:7]

Table 4-12 REG_SWIZZLE RGB Pins Mapping

REG_HCYCLE, REG_HSIZE, REG_HOFFSET, REG_HSYNC0 and REG_HSYNC1 define the LCD horizontal timings. Each register has 12 bits to allow programmable range of 0-4095 PCLK cycles. REG_VCYCLE, REG_VSIZE, REG_VOFFSET, REG_VSYNC0 and REG_VSYNC1 define the LCD vertical timings. Each register has 12 bits to allow a programmable range of 0-4095 lines.

	Register	Display Parameter	Description
Horizontal	REG_HCYCLE	T_H	Total length of line (visible and non-visible) (in PCLKs)
	REG_HSIZE	T_{HD}	Length of visible part of line (in PCLKs)
	REG_HOFFSET	$T_{HF} + T_{HP} + T_{HB}$	Length of non-visible part of line. Must be $< T_H - T_{HD}$ (in PCLK cycles)
	REG_HSYNC0	T_{HF}	Horizontal Front Porch (in PCLK cycles)
	REG_HSYNC1	$T_{HF} + T_{HP}$	Horizontal Front Porch plus Hsync Pulse width (in PCLK cycles)
Vertical	REG_VCYCLE	T_V	Total number of lines (visible and non-visible) (in lines)
	REG_VSIZE	T_{VD}	Number of visible lines (in lines)
	REG_VOFFSET	$T_{VF} + T_{VP} + T_{VB}$	Number of non-visible lines. Must be $< T_V - T_{VD}$ (in lines)
	REG_VSYNC0	T_{VF}	Vertical Front Porch (in lines)
	REG_VSYNC1	$T_{VF} + T_{VP}$	Vertical Front Porch plus Vsync Pulse width (in lines)

Table 4-13 Registers for RGB Horizontal and Vertical Timings

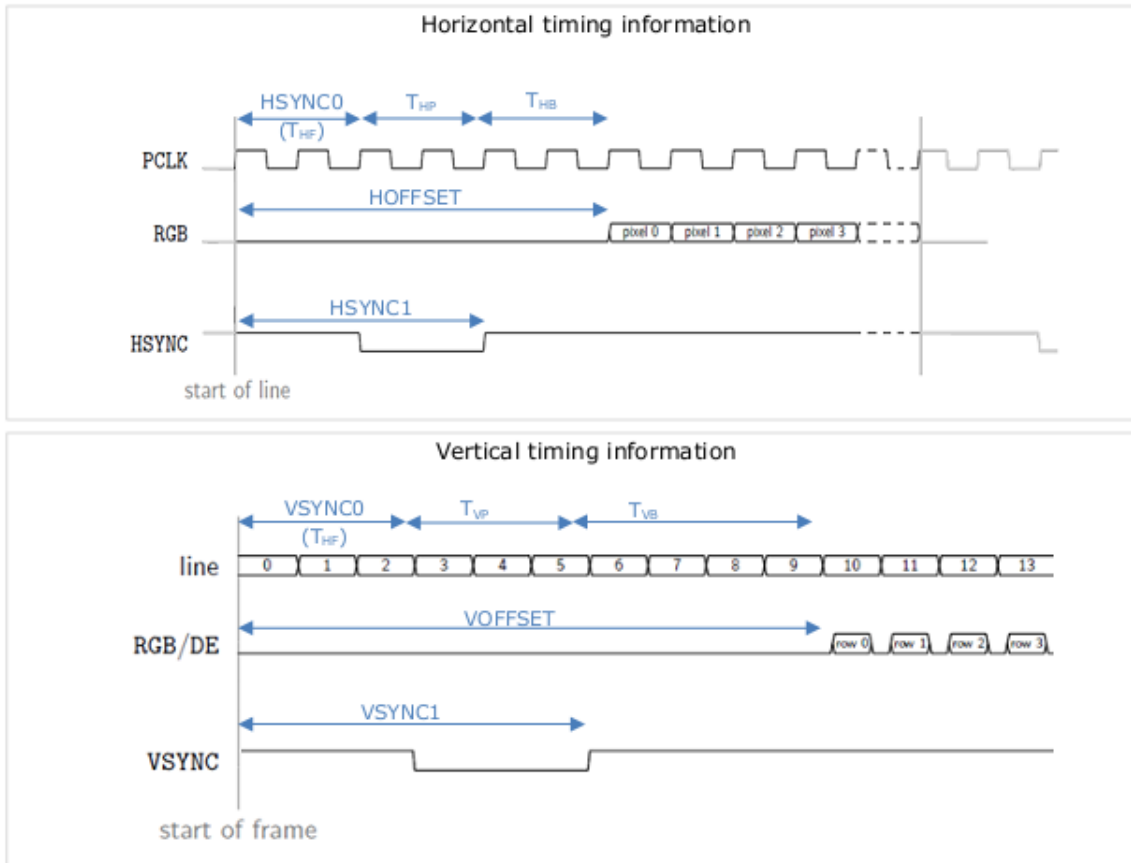

Figure 4-8 RGB Timing Waveforms

4.6 Miscellaneous Control

4.6.1 Backlight Control Pin

The backlight dimming control pin (BACKLIGHT) is a pulse width modulated (PWM) signal controlled by two registers: *REG_PWM_HZ* and *REG_PWM_DUTY*. *REG_PWM_HZ* specifies the PWM output frequency, the range is 250-10000 Hz. *REG_PWM_DUTY* specifies the duty cycle; the range is 0-128. A value of 0 means that the PWM is completely off and 128 means completely on.

The BACKLIGHT pin will output low when the DISP pin is not enabled (i.e. logic 0).

4.6.2 DISP Control Pin

The DISP pin is a general purpose output that can be used to enable, or reset the LCD display panel. The pin is controlled by writing to Bit 7 of the *REG_GPIO* register, or bit 15 of *REG_GPIOX*.

4.6.3 General Purpose IO pins

The BT815/6 can be configured to use up to 4 GPIO pins. These GPIO pins are controlled by the *REG_GPIOX_DIR* and *REG_GPIOX* registers. Alternatively the GPIO0 and GPIO1 pins can also be controlled by *REG_GPIO_DIR* and *REG_GPIO* to maintain backward compatibility with the FT800/FT801.

When the QSPI is enabled in Quad mode, GPIO0/IO2 and GPIO1/IO3 pins are used as data lines of the QSPI.

4.6.4 Pins Drive Current Control

The output drive current of output pins can be changed as per the following table by writing to bit[6:2] of REG_GPIO register or bit[14:10] of REG_GPIOX register. Alternatively, use the SPI command PINDRIVE to change the individual pin drive strength.

REG_GPIO	Bit[6:5]				Bit[4]		Bit[3:2]			
REG_GPIOX	Bit[14:13]				Bit[12]		Bit[11:10]			
Value	00b#	01b	10b	11b	0b#	1b	00b#	01b	10b	11b
Drive Current	5mA	10mA	15mA	20mA	1.2mA	2.4mA	5mA	10mA	15mA	20mA
Pins	GPIO0 GPIO1 GPIO2 GPIO3 CTP_RST_N				PCLK DISP VSYNC HSYNC DE R7..R0 G7..G0 B7..B0 BACKLIGHT		MISO MOSI IO2 IO3 INT_N			

Table 4-14 Output Drive Current Selection

Note: #Default value

4.7 Audio Engine

BT815/6 provides mono audio output with sigma-delta modulation through a digital output pin, AUDIO_L. It outputs two audio sources, the sound synthesizer and audio file playback.

4.7.1 Sound Synthesizer

A sound processor, AUDIO ENGINE, generates the sound effects from a small ROM library of waves table. To play a sound effect listed in Table 4.3, load the REG_SOUND register with a code value and write 1 to the REG_PLAY register. The REG_PLAY register reads 1 while the effect is playing and returns a '0' when the effect ends. Some sound effects play continuously until interrupted or instructed to play the next sound effect. To interrupt an effect, write a new value to REG_SOUND and REG_PLAY registers; e.g. write 0 (Silence) to REG_SOUND and 1 to PEG_PLAY to stop the sound effect.

The sound volume is controlled by register REG_VOL_SOUND. The 16-bit REG_SOUND register takes an 8-bit sound in the low byte. For some sounds, marked "pitch adjust" in the table below, the high 8 bits contain a MIDI note value. For these sounds, a note value of zero indicates middle C. For other sounds the high byte of REG_SOUND is ignored.

Value	Effect	Contin uous	Pitch adjust
00h	Silence	Y	N
01h	square wave	Y	Y
02h	sine wave	Y	Y
03h	sawtooth wave	Y	Y

Value	Effect	Contin uous	Pitch adjust
32h	DTMF 2	Y	N
33h	DTMF 3	Y	N
34h	DTMF 4	Y	N
35h	DTMF 5	Y	N

04h	triangle wave	Y	Y
05h	Beeping	Y	Y
06h	Alarm	Y	Y
07h	Warble	Y	Y
08h	Carousel	Y	Y
10h	1 short pip	N	Y
11h	2 short pips	N	Y
12h	3 short pips	N	Y
13h	4 short pips	N	Y
14h	5 short pips	N	Y
15h	6 short pips	N	Y
16h	7 short pips	N	Y
17h	8 short pips	N	Y
18h	9 short pips	N	Y
19h	10 short pips	N	Y
1Ah	11 short pips	N	Y
1Bh	12 short pips	N	Y
1Ch	13 short pips	N	Y
1Dh	14 short pips	N	Y
1Eh	15 short pips	N	Y
1Fh	16 short pips	N	Y
23h	DTMF #	Y	N
2Ch	DTMF *	Y	N
30h	DTMF 0	Y	N
31h	DTMF 1	Y	N
36h	DTMF 6	Y	N
37h	DTMF 7	Y	N
38h	DTMF 8	Y	N
39h	DTMF 9	Y	N
40h	harp	N	Y
41h	xylophone	N	Y
42h	tuba	N	Y
43h	glockenspiel	N	Y
44h	organ	N	Y
45h	trumpet	N	Y
46h	piano	N	Y
47h	chimes	N	Y
48h	music box	N	Y
49h	bell	N	Y
50h	click	N	N
51h	switch	N	N
52h	cowbell	N	N
53h	notch	N	N
54h	hihat	N	N
55h	kickdrum	N	N
56h	pop	N	N
57h	clack	N	N
58h	chack	N	N
60h	mute	N	N
61h	unmute	N	N

Table 4-15 Sound Effect

MIDI note	ANSI note	Freq (Hz)
21	A0	27.5
22	A#0	29.1
23	B0	30.9
24	C1	32.7
25	C#1	34.6
26	D1	36.7
27	D#1	38.9
28	E1	41.2
29	F1	43.7
30	F#1	46.2
31	G1	49.0
32	G#1	51.9
33	A1	55.0
34	A#1	58.3
35	B1	61.7
36	C2	65.4
37	C#2	69.3
38	D2	73.4
39	D#2	77.8
40	E2	82.4
41	F2	87.3
42	F#2	92.5

MIDI note	ANSI note	Freq (Hz)
65	F4	349.2
66	F#4	370.0
67	G4	392.0
68	G#4	415.3
69	A4	440.0
70	A#4	466.2
71	B4	493.9
72	C5	523.3
73	C#5	554.4
74	D5	587.3
75	D#5	622.3
76	E5	659.3
77	F5	698.5
78	F#5	740.0
79	G5	784.0
80	G#5	830.6
81	A5	880.0
82	A#5	932.3
83	B5	987.8
84	C6	1046.5
85	C#6	1108.7
86	D6	1174.7

43	G2	98.0	87	D#6	1244.5
44	G#2	103.8	88	E6	1318.5
45	A2	110.0	89	F6	1396.9
46	A#2	116.5	90	F#6	1480.0
47	B2	123.5	91	G6	1568.0
48	C3	130.8	92	G#6	1661.2
49	C#3	138.6	93	A6	1760.0
50	D3	146.8	94	A#6	1864.7
51	D#3	155.6	95	B6	1975.5
52	E3	164.8	96	C7	2093.0
53	F3	174.6	97	C#7	2217.5
54	F#3	185.0	98	D7	2349.3
55	G3	196.0	99	D#7	2489.0
56	G#3	207.7	100	E7	2637.0
57	A3	220.0	101	F7	2793.8
58	A#3	233.1	102	F#7	2960.0
59	B3	246.9	103	G7	3136.0
60	C4	261.6	104	G#7	3322.4
61	C#4	277.2	105	A7	3520.0
62	D4	293.7	106	A#7	3729.3
63	D#4	311.1	107	B7	3951.1
64	E4	329.6	108	C8	4186.0

Table 4-16 MIDI Note Effect

4.7.2 Audio Playback

The BT815/6 can play back recorded sound through its audio output. To do this, load the original sound data into the BT815/6's RAM, and set registers to start the playback.

The registers controlling audio playback are:

REG_PLAYBACK_START:	the start address of the audio data
REG_PLAYBACK_LENGTH:	the length of the audio data, in bytes
REG_PLAYBACK_FREQ:	the playback sampling frequency, in Hz
REG_PLAYBACK_FORMAT:	the playback format, one of LINEAR SAMPLES, uLAW SAMPLES, or ADPCM SAMPLES
REG_PLAYBACK_LOOP:	if zero, the sample is played once. If one, the sample is repeated indefinitely
REG_PLAYBACK_PLAY:	a write to this location triggers the start of audio playback, regardless of writing '0' or '1'. Read back '1' when playback is ongoing, and '0' when playback finishes
REG_VOL_PB:	playback volume, 0-255

The mono audio formats supported are 8-bits PCM, 8-bits uLAW and 4-bits IMA-ADPCM. For ADPCM_SAMPLES, each sample is 4 bits, so two samples are packed per byte, the first sample is in bits 0-3 and the second is in bits 4-7.

The current audio playback read pointer can be queried by reading the REG_PLAYBACK_READPTR. Using a large sample buffer, looping, and this read pointer, the host MPU/MCU can supply a continuous stream of audio.

4.8 Touch-Screen Engine

The BT815/6 touch-screen engine supports both resistive and capacitive touch panels. BT816 supports resistive touch, while BT815 supports capacitive touch.

4.8.1 Resistive Touch Control

The resistive touch-screen consists of a touch screen engine, ADC, Axis-switches, and ADC input multiplexer. The touch screen engine reads commands from the memory map register and generates the required control signals to the axis-switches and inputs mux and ADC. The ADC data are acquired, processed and updated in the respective register for the MPU/MCU to read.

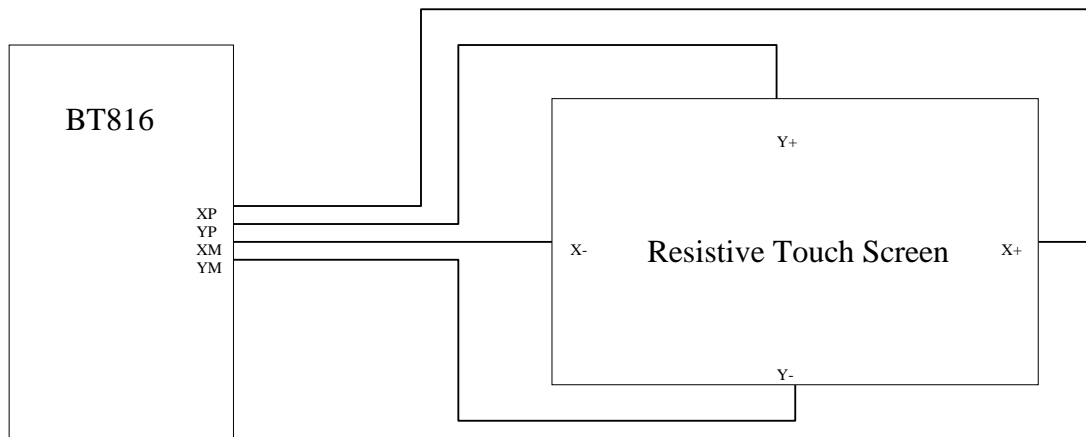

Figure 4-9 Resistive Touch Screen Connection

The host controls the TOUCH SCREEN ENGINE operation mode by writing the REG_TOUCH_MODE.

REG_TOUCH_MODE	Mode	Description
0	OFF	Acquisition stopped, only touch detection interrupt is still valid.
1	ONE-SHOT	Perform acquisition once every time the MPU writes '1' to REG_TOUCH_MODE.
2	FRAME-SYNC	Perform acquisition for every frame sync (~60 data acquisition/second).
3	CONTINUOUS	Perform acquisition continuously at approximately 1000 data acquisition / second.

Table 4-17 Resistive Touch Controller Operating Mode

The Touch Screen Engine captures the raw X and Y coordinate and writes to register REG_TOUCH_RAW XY. The range of these values is 0-1023. If the touch screen is not being pressed, both registers read 65535 (FFFFh).

These touch values are transformed into screen coordinates using the matrix in registers REG_TOUCH_TRANSFORM_A-F. The post-transform coordinates are available in register REG_TOUCH_SCREEN_XY. If the touch screen is not being pressed, both registers read -32768 (8000h).

The values for REG TOUCH TRANSFORM A-F may be computed using an on-screen calibration process.

If the screen is being touched, the screen coordinates are looked up in the screen's tag buffer, delivering a final 8-bit tag value, in REG TOUCH TAG. Because the tag lookup takes a full frame, and touch coordinates change continuously, the original (x; y) used for the tag lookup is also available in REG_TOUCH_TAG_XY.

Screen touch pressure is available in REG_TOUCH_RZ. The value is relative to the resistance of the touch contact, a lower value indicates more pressure. The register defaults to 32767 when touch is not detected. The REG_TOUCH_THRESHOLD can be set to accept a touch only when the force threshold is exceeded.

4.8.2 Capacitive Touch Control

The Capacitive Touch Screen Engine (CTSE) of the BT815 communicates with the external capacitive touch panel module (CTPM) through an I²C interface. The CTPM will assert its interrupt line when there is a touch detected. Upon detecting CTP_INT_N line active, the BT815/6 will read the touch data through I²C. Up to 5 touches can be reported and stored in BT815 registers.

The BT815 CTSE supports Focaltech and Goodix touch controllers, as well as touch host mode (refer to section 4.8.7). For a supported CTPM list please refer to [AN_336_FT8xx - Selecting an LCD Display](#).

The BT815 uses the I2C address value in the REG_TOUCH_CONFIG register to differentiate Focaltech or Goodix touch controllers. For Focaltech IC the I2C address must be set as 0x38-0x3F (example: REG_TOUCH_CONFIG = 0x0380), while for Goodix IC the I2C address must be set as 0x5D (example: REG_TOUCH_CONFIG = 0x05D0).

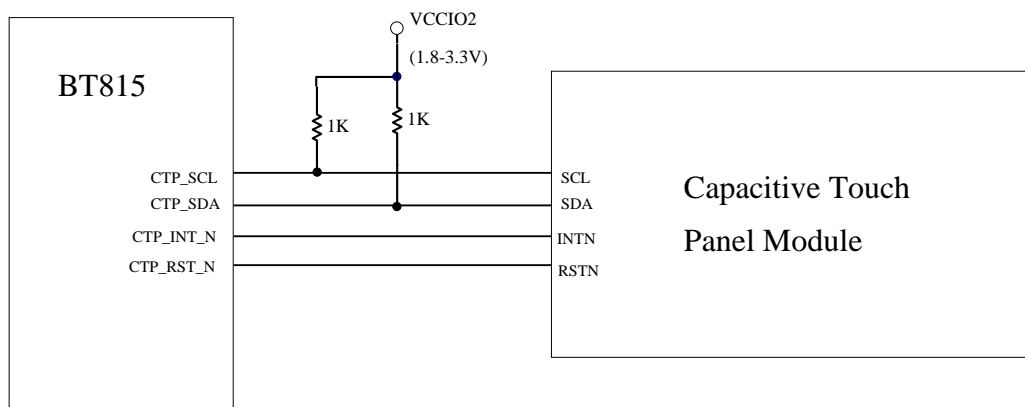

Figure 4-10 Touch Screen Connection

The host controls the CTSE operation mode by writing the REG_CTOUCH_MODE.

REG_CTOUCH_MODE	Mode	Description
0	OFF	Acquisition stopped
1-2	Reserved	Reserved
3	CONTINUOUS	Perform acquisition continuously at the reporting rate of the connected CTPM.

Table 4-18 Capacitive Touch Controller Operating Mode

The BT815 CTSE supports compatibility mode and extended mode. By default the CTSE runs in compatibility mode where the touch system provides an interface very similar to the resistive touch engine. In extended mode, the touch register meanings are modified, and a second set of registers are exposed. These allow multi-touch detection (up to 5 touches).

4.8.3 Compatibility Mode

The CTSE reads the X and Y coordinates from the CTPM and writes to register REG_CTOUCH_RAW_XY. If the touch screen is not being pressed, both registers read 65535 (FFFFh).

These touch values are transformed into screen coordinates using the matrix in registers REG_CTOUCH_TRANSFORM_A-F. The post-transform coordinates are available in register REG_CTOUCH_SCREEN_XY. If the touch screen is not being pressed, both registers read -32768 (8000h). The values for REG_CTOUCH_TRANSFORM_A-F may be computed using an on-screen calibration process. If the screen is being touched, the screen coordinates are looked up in the screen's tag buffer, delivering a final 8-bit tag value, in REG_TOUCH_TAG. Because the tag lookup takes a full frame, and touch coordinates change continuously, the original (x; y) used for the tag lookup is also available in REG_TOUCH_TAG_XY.

4.8.4 Extended Mode

Setting REG_CTOUCH_EXTENDED to 1b'0 enables extended mode. In extended mode a new set of readout registers are available, allowing gestures and up to five touches to be read. There are two classes of registers: control registers and status registers. Control registers are written by the MCU. Status registers can be read out by the MCU and the BT815/6's hardware tag system.

The five touch coordinates are packed in REG_CTOUCH_TOUCH0_XY, REG_CTOUCH_TOUCH1_XY, REG_CTOUCH_TOUCH2_XY, REG_CTOUCH_TOUCH3_XY, REG_CTOUCH4_X and REG_CTOUCH4_Y.

Coordinates stored in these registers are signed 16-bit values, so have a range of -32768 to 32767. The no-touch condition is indicated by x=y= -32768. These coordinates are already transformed into screen coordinates based on the raw data read from the CTPM, using the matrix in registers REG_CTOUCH_TRANSFORM_A-F. To obtain raw (x,y) coordinates read from CTPM, the user sets the REG_CTOUCH_TRANSFORM_A-F registers to the identity matrix.

The BT815/6 tag mechanism is implemented by hardware, where up to 5 tags can be looked up.

4.8.5 Short-Circuit Protection

For resistive touch it is useful to protect the chip from permanent damage due to potential short-circuits on the 4 XY lines. When a short circuit on the touch screen happens, the BT816 can detect it and stop the touch detection operation, leaving the 4 XY pins in the high impedance state.

The short-circuit protection can be enabled/disabled by the REG_TOUCH_CONFIG.

4.8.6 Capacitive Touch Configuration

On a capacitive touch system some users may need to adjust the CTPM default values, such as the registers affecting touch sensitivity. To do this the following sequence shall be executed once after chip reset:

- Hold the touch engine in reset (set REG_CPURESET = 2)
- Write the CTPM configure register address and value to the BT815 designated memory location
- Up to 10 register address/value can be added
- Release the touch engine reset (set REG_CPURESET = 0)

The CTPM can be enabled in low power state when the touch function is not required by the application. Setting the low-power bit in REG_TOUCH_CONFIG will enable the low power mode of the CTPM. When the low-power bit is cleared, the BT815 touch engine will send a reset to the CTPM, thus re-enabling the touch detection function.

4.8.7 Host Driven Multi-Touch

If the host MCU can provide touch inputs, it can supply them directly to the BT815 using touch host mode. By using touch host mode, an application can choose to select a touch controller that is not in the BT815 direct support list. For example, Touch Host mode would allow controllers to be used from other manufacturers beyond Focaltex and Goodix.

To use the touch host mode, the host MCU shall be connected to the touch panel directly. The four touch related pins of the BT815 can be left unconnected on the PCB. The host MCU is responsible for

communicating with the touch controller, fetching the touch data when reported, and writing the touch data to the BT815 for touch TAG lookup and reporting.

The touch host mode can be entered by setting bit 14 in register REG_TOUCH_CONFIG and resetting the touch engine:

- Hold the touch engine in reset (set REG_CPURESET = 2)
- Write 1 to bit 14 in REG_TOUCH_CONFIG (set REG_TOUCH_CONFIG = 0x4000)
- Release the touch engine reset (set REG_CPURESET = 0)

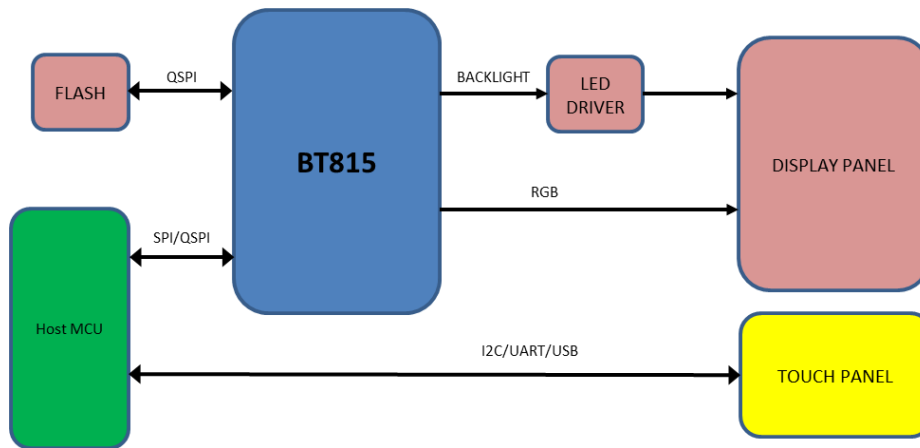

Figure 4-11 Touch Host Mode Connections

In touch host mode, the host supplies touch information via four registers:

BT815 address	Register Name	Bits	Description
0x30210c	REG_EHOST_TOUCH_X	Unsigned 16-bit	Touch x coordinate
0x302118	REG_EHOST_TOUCH_Y	Unsigned 16-bit	Touch y coordinate
0x302114	REG_EHOST_TOUCH_ID	4-bit	Touch ID / phase
0x302170	REG_EHOST_TOUCH_ACK	4-bit	Acknowledgement

Table 4-19 Registers for Touch Host Mode

The host writes raw (x; y) coordinates and IDs to the above registers. Up to 5 touches can be set, using touch IDs 0-4. The host indicates no touch by supplying coordinates (0x8000; 0x8000). When the host writes 0xf to the ID register, BT815 sets the ACK register to 0, transforms all the raw coordinates, and writes the results to the regular touch registers.

Pseudocode:

```

wait until REG_EHOST_TOUCH_ACK is 1
for each touch:
    write x coordinate to REG_EHOST_TOUCH_X
    write y coordinate to REG_EHOST_TOUCH_Y
    write id to REG_EHOST_TOUCH_ID
write 0xf to REG_EHOST_TOUCH_ID
  
```

As soon as BT815 has converted the coordinates, it writes 1 to the ACK register and sets the INT_CONV_COMPLETE interrupt flag.

The ID should be zero in touch compatibility mode. The host should indicate no touch at all by writing (0x8000; 0x8000) with ID 0.

In extended mode, the multiple touches may be sent in any order. Any IDs not assigned are assumed to be not pressed. Again, the host should indicate no touch at all by writing (0x8000; 0x8000) with ID 0.

The host can use three methods to ensure that BT815 is ready to accept touch inputs:

1. poll the ACK register until it is 1
2. use the INT_CONV_COMPLETE interrupt flag
3. supply touches slower than 1000 Hz, since BT815 guarantees to process the touches in under 1 ms. Note that report rates from capacitive touch panels are about 100 Hz

Like the direct capacitive driver, this touch host mode works when REG_CTOUCH_EXTENDED is both CTOUCH_MODE_EXTENDED and CTOUCH_MODE_COMPATIBILITY. CTOUCH_MODE_COMPATIBILITY should be used for the calibration procedure, just as when using native capacitive support. After changing mode, the BT815 touch engine must be reset.

4.8.8 Touch Detection in none-ACTIVE State

When the BT815/6 is in none-ACTIVE state, a touch event can still be detected and reported to the host through the INT_N pin. In other words, a touch event can wake-up the host if needed.

For resistive touch, the INT_N pin will be asserted low when the screen is touched, regardless of the setting of the interrupt registers. This will happen when the BT816 is in STANDBY or SLEEP state, but not in POWERDOWN state.

For capacitive touch, the INT_N pin will follow CTP_INT_N pin when the BT815 is in STANDBY, SLEEP or POWERDOWN state.

4.9 Power Management

4.9.1 Power Supply

The BT815/6 may be operated with a single supply of 3.3V applied to VCC and VCCIO pins. For operation with a host MPU/MCU at a lower supply, connect the VCCIO1 to the MPU IO supply to match the interface voltage. For operation with LCD/touch panels at lower voltages, connect the VCCIO2 to the LCD/touch IO supply.

Symbol	Typical	Description
VCCIO1	1.8V, or 2.5V, or 3.3V	Supply for Host interface digital I/O pins
VCCIO2	1.8V, or 2.5V, or 3.3V	Supply for RGB and touch interface I/O pins
VCCIO3	1.8V, or 2.5V, or 3.3V	Supply for NOR Flash interface I/O pins
VCCA	3.3V	Supply for AUDIO_L pin and ADC circuit
VCC	3.3V	Supply for 3.3V circuits and internal 1.2V regulator
VOUT1V2, VCC1V2	1.2V	Supply for digital core. Generated by internal regulator

Table 4-20 Power Supply

4.9.2 Internal Regulator and POR

The internal regulator provides power to the core circuit. A 47kΩ resistor is recommended to pull the PD_N pin up to VCCIO1, together with a 100nF capacitor to ground in order to delay the internal regulator powering up after the VCC and VCCIO are stable.

The internal regulator requires a compensation capacitor to be stable. A typical design requires a 4.7uF capacitor between the VOUT1V2 and GND pins. Do not connect any other load to the VOUT1V2 pin.

The internal regulator will generate a Power-On-Reset (POR) pulse when the output voltage rises above the POR threshold. The POR will reset all the core digital circuits.

It is possible to use the PD_N pin as an asynchronous hardware reset input. Drive PD_N low for at least 5ms and then drive it high will reset the BT815/6 chip.

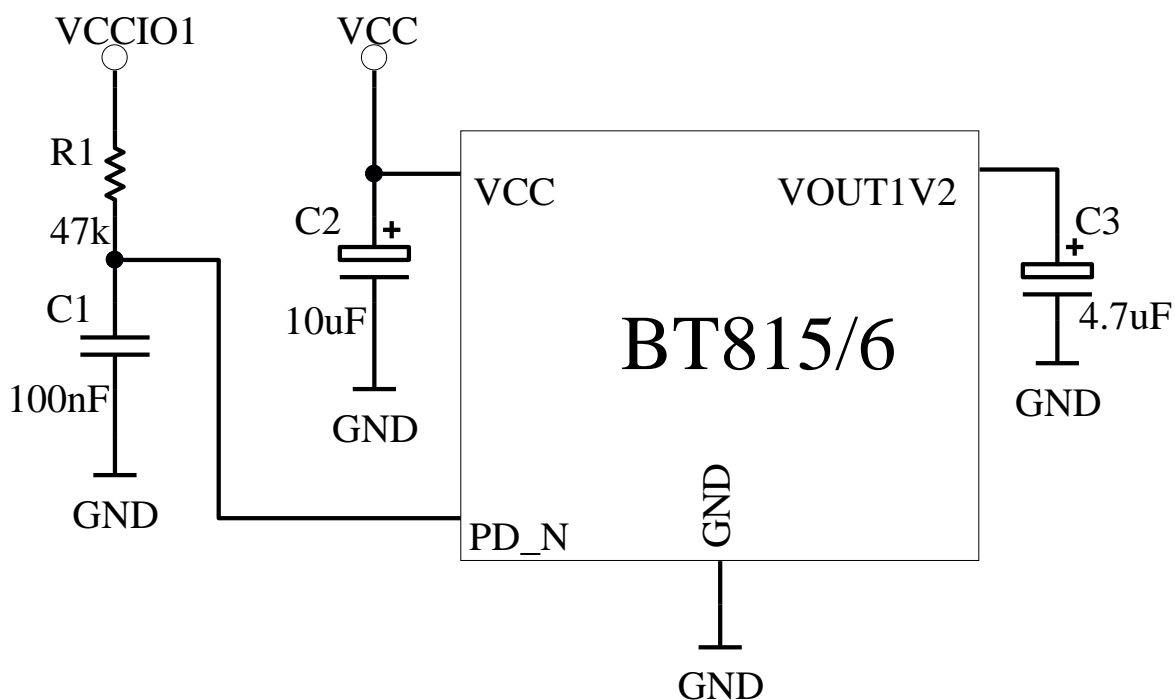

Figure 4-12 Internal Regulator

4.9.3 Power Modes

When the supply to VCCIO and VCC is applied, the internal regulator is powered by VCC. An internal POR pulse will be generated during the regulator power up until it is stable. After the initial power up, the BT815/6 will stay in the SLEEP state. When needed, the host can set the BT815/6 to the ACTIVE state by performing a SPI ACTIVE command. The graphics engine, the audio engine and the touch engine are only functional in the ACTIVE state. To save power the host can send a command to put the BT815/6 into any of the low power modes: STANDBY, SLEEP and POWERDOWN. In addition, the host is allowed to put the BT815/6 in POWERDOWN mode by driving the PD_N pin to low, regardless of what state it is currently in. Refer to Figure 4-13 for the power state transitions.

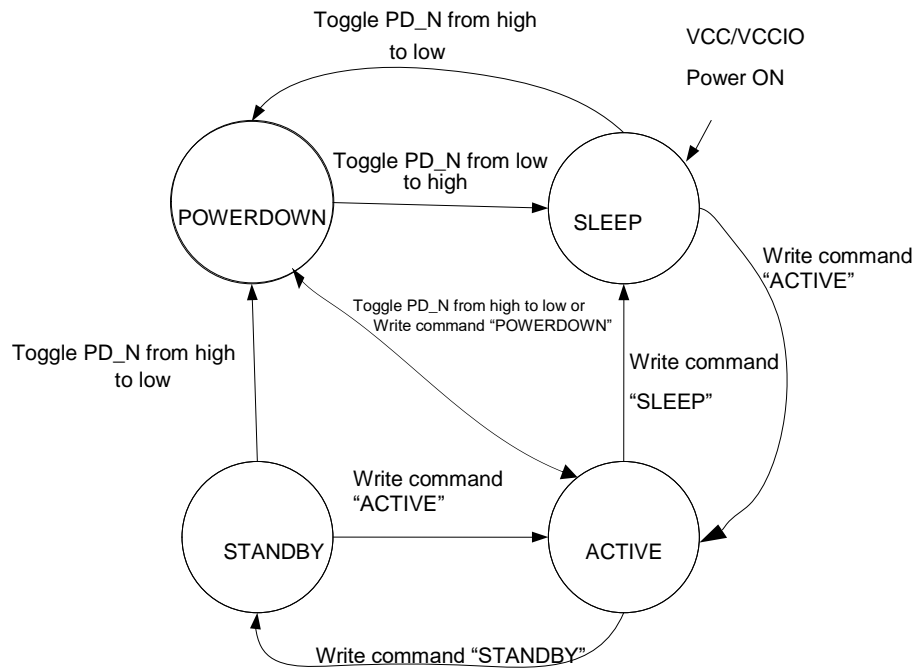

Figure 4-13 Power State Transition

4.9.3.1 ACTIVE state

In ACTIVE state, the BT815/6 is in normal operation. The clock oscillator and PLL are functioning. The system clock applied to the BT815/6 core engines is enabled.

4.9.3.2 STANDBY state

In STANDBY state, the clock oscillator and PLL remain functioning; the system clock applied to the BT815/6 core engines is disabled. All register contents are retained.

4.9.3.3 SLEEP state

In SLEEP state, the clock oscillator, PLL and system clock applied to the BT815/6 core engines are disabled. All register contents are retained.

4.9.3.4 POWERDOWN state

In POWERDOWN state, the clock oscillator, the PLL and the system clock applied to the BT815/6 core is disabled. The core engines are powered down while the SPI interface for host commands remains functional. All register contents are lost and reset to default when the chip is next switched on. The internal regulator remains on.

4.9.3.5 Wake up to ACTIVE from other power states

When in the POWER DOWN state, if the device enters this state via an SPI command, then only the SPI ACTIVE command will bring the device back to the ACTIVE state, provided PD_N pin is also high. However, if PD_N is used instead, then making PD_N high followed by a SPI ACTIVE command will wake up the device. Upon exiting this state, the device will perform a global reset, and will go through the same power up sequence. All settings from SPI commands will be reset except those that pertain to pin states during power down. The clock enable sequence mentioned in section 4.2.3 shall be executed to properly select and enable the system clock.

From the SLEEP state, the host MPU sends an SPI ACTIVE command to wake the BT815/6 into the ACTIVE state. The host needs to wait for at least 20ms before accessing any registers or commands. This is to guarantee the clock oscillator and PLL are up and stable.

From the STANDBY state, the host MPU sends SPI ACTIVE command to wake the BT815/6 into the ACTIVE state. The host can immediately access any register or command.

4.9.4 Reset and Boot-up Sequence

There are a few hardware and software reset events which can be triggered to reset the BT815/6.

Hardware reset events:

- Power-on-Reset(POR)
- Toggle the PD_N pin

Software reset events:

- SPI command RST_PULSE
- SPI command to switch between the internal clock and the external clock
- SPI command to enter POWERDOWN then wakeup

After reset the BT815/6 will be in the SLEEP state. Upon receiving the SPI ACTIVE command (or CLKEXT followed by SPI ACTIVE command if external clock source is used), the clock oscillator and PLL will start up. Once the clock is stable, the chip will check and repair its internal RAM, running the configuration and release the clock to the system. The chip will exit the reset and boot-up state and enter into normal operations. The boot-up may take up to 300ms to complete. During boot up process, software should not access BT815/6 register or RAM.

4.9.5 Pin Status at Different Power States

The BT815/6 pin status depends on the power state of the chip. See the following table for more details. At the power transition from ACTIVE to STANDBY or ACTIVE to SLEEP, all pins retain their previous status. The software needs to set AUDIO_L, BACKLIGHT to a known state before issuing power transition commands.

The pin status in the power down state can be changed by SPI command PIN_PD_STATE.

Pin Name	Default Drive	Reset	Normal	Power Down (Default)
AUDIO_L	20mA	Out, Float	Out	Retain
SCK	-	In	In	In
MISO	5mA	Out, Float (CS_N = 1)	IO	Out, Float
MOSI	5mA	In	IO	In
CS_N	-	In	In	In
IO2	5mA	In	IO	Float
GPIO0	5mA	In	IO	Float
IO3	5mA	In	IO	Float
GPIO1	5mA	In	IO	Float
GPIO2	5mA	In	IO	Float

Pin Name	Default Drive	Reset	Normal	Power Down (Default)
INT_N	5mA	OD, Float	OD / Out	Float
PD_N	-	In	In	In
GPIO3	5mA	In	IO	Float
SPIM_SCLK	5mA	In	Out	Float
SPIM_MISO	5mA	In	IO	Float
SPIM_MOSI	5mA	In	IO	Float
SPIM_SS_N	5mA	In	Out	Float
SPIM_IO2	5mA	In	IO	Float
SPIM_IO3	5mA	In	IO	Float
X1/CLK	-	In	In	In
XP	-	IO, Float	IO	Retain
YP	-	IO, Float	IO	Retain
XM	-	IO, Float	IO	Retain
YM	-	IO, Float	IO	Retain
CTP_RST_N	5mA	Out	Out	Pull Low
CTP_INT_N	5mA	In	I/O	In
CTP_SCL	20mA	OD	IO	Float
CTP_SDA	20mA	OD	IO	Float
BACKLIGHT	1.2mA	Out	Out	Pull Low
DE	1.2mA	Out	Out	Pull Low
VSYNC	1.2mA	Out	Out	Pull Low
HSYNC	1.2mA	Out	Out	Pull Low
DISP	1.2mA	Out	Out	Pull Low
PCLK	1.2mA	Out	Out	Pull Low
R/G/B	1.2mA	Out	Out	Pull Low

Table 4-21 Pin Status

5 Memory Map

All memory and registers in the BT815/6 core are memory mapped in 22-bit address space with a 2-bit SPI command prefix. Prefix 0'b00 for read and 0'b10 for write to the address space, 0'b01 is reserved for Host Commands and 0'b11 undefined. The following are the memory space definition.

Start Address	End Address	Size	NAME	Description
00 0000h	0F FFFFh	1024 kB	RAM_G	General purpose graphics RAM
20 0000h	2F FFFFh	1024 kB	ROM	ROM codes, font table and bitmap
30 0000h	30 1FFFh	8 kB	RAM_DL	Display List RAM
30 2000h	30 2FFFh	4 kB	RAM_REG	Registers
30 8000h	30 8FFFh	4 kB	RAM_CMD	Command buffer
80 0000h	107F FFFFh	256 MB	FLASH	External NOR flash memory. Maximum 256MB. The address is used by internal command only.

Table 5-1 BT815/6 Memory Map

Note 1: The addresses beyond this table are reserved and shall not be read or written unless otherwise specified.

5.1 Registers

Table 5-2 shows the complete list of the BT815/6 registers. Refer to [BT81X_Series_Programming_Guide](#), Chapter 3 for details of the register function.

Address (hex)	Register Name	Bits	r/w	Reset value	Description
302000h	REG_ID	8	r/o	7Ch	Identification register, always reads as 7Ch
302004h	REG_FRAMES	32	r/o	0	Frame counter, since reset
302008h	REG_CLOCK	32	r/o	0	Clock cycles, since reset
30200Ch	REG_FREQUENCY	28	r/w	60000000	Main clock frequency (Hz)
302010h	REG_RENDERMODE	1	r/w	0	Rendering mode: 0 = normal, 1 = single-line
302014h	REG_SNAPY	11	r/w	0	Scanline select for RENDERMODE 1
302018h	REG_SNAPSHOT	1	r/w	-	Trigger for RENDERMODE 1
30201Ch	REG_SNAPFORMAT	6	r/w	20h	Pixel format for scanline readout
302020h	REG_CPURESET	3	r/w	2	Graphics, audio and touch engines reset control. Bit2: audio, bit1: touch, bit0: graphics

Address (hex)	Register Name	Bits	r/w	Reset value	Description
302024h	REG_TAP_CRC	32	r/o	-	Live video tap crc. Frame CRC is computed every DL SWAP.
302028h	REG_TAP_MASK	32	r/w	FFFFFFFFh	Live video tap mask
30202Ch	REG_HCYCLE	12	r/w	224h	Horizontal total cycle count
302030h	REG_HOFFSET	12	r/w	02Bh	Horizontal display start offset
302034h	REG_HSIZE	12	r/w	1E0h	Horizontal display pixel count
302038h	REG_HSYNC0	12	r/w	000h	Horizontal sync fall offset
30203Ch	REG_HSYNC1	12	r/w	029h	Horizontal sync rise offset
302040h	REG_VCYCLE	12	r/w	124h	Vertical total cycle count
302044h	REG_VOFFSET	12	r/w	00Ch	Vertical display start offset
302048h	REG_VSIZE	12	r/w	110h	Vertical display line count
30204Ch	REG_VSYNC0	10	r/w	000h	Vertical sync fall offset
302050h	REG_VSYNC1	10	r/w	00Ah	Vertical sync rise offset
302054h	REG_DLSWAP	2	r/w	0	Display list swap control
302058h	REG_ROTATE	3	r/w	0	Screen rotation control. Allow normal/mirrored/inverted for landscape or portrait orientation.
30205Ch	REG_OUTBITS	9	r/w	0	Output bit resolution, 3 register bits each for R/G/B. 0 indicates 8 bits, 1-7 indicates 1-7 bits respectively.
302060h	REG_DITHER	1	r/w	1	Output dither enable
302064h	REG_SWIZZLE	4	r/w	0	Output RGB signal swizzle
302068h	REG_CSPREAD	1	r/w	1	Output clock spreading enable
30206Ch	REG_PCLK_POL	1	r/w	0	PCLK polarity: 0 = output on PCLK rising edge, 1 = output on PCLK falling edge
302070h	REG_PCLK	8	r/w	0	PCLK frequency divider, 0 = disable
302074h	REG_TAG_X	11	r/w	0	Tag query X coordinate
302078h	REG_TAG_Y	11	r/w	0	Tag query Y coordinate
30207Ch	REG_TAG	8	r/o	0	Tag query result
302080h	REG_VOL_PB	8	r/w	FFh	Volume for playback
302084h	REG_VOL_SOUND	8	r/w	FFh	Volume for synthesizer sound
302088h	REG_SOUND	16	r/w	0	Sound effect select

Address (hex)	Register Name	Bits	r/w	Reset value	Description
30208Ch	REG_PLAY	1	r/w	0h	Start effect playback
302090h	REG_GPIO_DIR	8	r/w	80h	Legacy GPIO pin direction, 0 = input , 1 = output
302094h	REG_GPIO	8	r/w	00h	Legacy GPIO read/write
302098h	REG_GPIOX_DIR	16	r/w	8000h	Extended GPIO pin direction, 0 = input , 1 = output
30209Ch	REG_GPIOX	16	r/w	0080h	Extended GPIO read/write
3020A0h-3020A4h	Reserved	-	-	-	Reserved
3020A8h	REG_INT_FLAGS	8	r/o	00h	Interrupt flags, clear by read
3020Ach	REG_INT_EN	1	r/w	0	Global interrupt enable, 1=enable
3020B0h	REG_INT_MASK	8	r/w	FFh	Individual interrupt enable, 1=enable
3020B4h	REG_PLAYBACK_START	20	r/w	0	Audio playback RAM start address
3020B8h	REG_PLAYBACK_LENGTH	20	r/w	0	Audio playback sample length (bytes)
3020BCh	REG_PLAYBACK_READPTR	20	r/o	-	Audio playback current read pointer
3020C0h	REG_PLAYBACK_FREQ	16	r/w	8000	Audio playback sampling frequency (Hz)
3020C4h	REG_PLAYBACK_FORMAT	2	r/w	0	Audio playback format
3020C8h	REG_PLAYBACK_LOOP	1	r/w	0	Audio playback loop enable
3020CCh	REG_PLAYBACK_PLAY	1	r/w	0	Start audio playback
3020D0h	REG_PWM_HZ	14	r/w	250	BACKLIGHT PWM output frequency (Hz)
3020D4h	REG_PWM_DUTY	8	r/w	128	BACKLIGHT PWM output duty cycle 0=0%, 128=100%
3020D8h	REG_MACRO_0	32	r/w	0	Display list macro command 0
3020DCh	REG_MACRO_1	32	r/w	0	Display list macro command 1
3020E0h - 3020F4h	Reserved	-	-	-	Reserved
3020F8h	REG_CMD_READ	12	r/w	0	Command buffer read pointer
3020FCh	REG_CMD_WRITE	12	r/o	0	Command buffer write pointer
302100h	REG_CMD_DL	13	r/w	0	Command display list offset
302104h	REG_TOUCH_MODE	2	r/w	3	Touch-screen sampling mode
302108h	REG_TOUCH_ADC_MODE REG_CTOUCH_EXTENDED	1	r/w	1	Set Touch ADC mode Set capacitive touch operation mode:

Address (hex)	Register Name	Bits	r/w	Reset value	Description
					0: extended mode (multi-touch) 1: FT800 compatibility mode (single touch).
30210Ch	REG_TOUCH_CHARGE REG_EHOST_TOUCH_X	16	r/w	9000	Touch charge time, units of 6 clocks Touch host mode: touch x value updated by host
302110h	REG_TOUCH_SETTLE	4	r/w	3	Touch settle time, units of 6 clocks
302114h	REG_TOUCH_OVERSAMPLE REG_EHOST_TOUCH_ID	4	r/w	7	Touch oversample factor Touch host mode: touch ID, 0-4
302118h	REG_TOUCH_RZTHRESH REG_EHOST_TOUCH_Y	16	r/w	FFFFh	Touch resistance threshold Touch host mode: touch x value updated by host
30211Ch	REG_TOUCH_RAW_XY REG_CTOUCH_TOUCH1_XY	32	r/o	-	Compatibility mode: touch-screen raw (x-MSB16; y-LSB16) Extended mode: touch-screen screen data for touch 1 (x-MSB16; y-LSB16)
302120h	REG_TOUCH_RZ REG_CTOUCH_TOUCH4_Y	16	r/o	-	Compatibility mode: touch-screen resistance Extended mode: touch-screen screen Y data for touch 4
302124h	REG_TOUCH_SCREEN_XY REG_CTOUCH_TOUCH0_XY	32	r/o	-	Compatibility mode: touch-screen screen (x-MSB16; y-LSB16) Extended mode: touch-screen screen data for touch 0 (x-MSB16; y-LSB16)
302128h	REG_TOUCH_TAG_XY	32	r/o	-	Touch-screen screen (x-MSB16; y-LSB16) used for tag 0 lookup
30212Ch	REG_TOUCH_TAG	8	r/o	-	Touch-screen tag result 0
302130h	REG_TOUCH_TAG1_XY	32	r/o	-	Touch-screen screen (x-MSB16; y-LSB16) used for tag 1 lookup
302134h	REG_TOUCH_TAG1	8	r/o	-	Touch-screen tag result 1
302138h	REG_TOUCH_TAG2_XY	32	r/o	-	Touch-screen screen (x-MSB16; y-LSB16) used for tag 2 lookup
30213Ch	REG_TOUCH_TAG2	8	r/o	-	Touch-screen tag result 2
302140h	REG_TOUCH_TAG3_XY	32	r/o	-	Touch-screen screen (x-MSB16; y-LSB16) used for tag 3 lookup
302144h	REG_TOUCH_TAG3	8	r/o	-	Touch-screen tag result 3

Address (hex)	Register Name	Bits	r/w	Reset value	Description
302148h	REG_TOUCH_TAG4_XY	32	r/o	-	Touch-screen screen (x-MSB16; y-LSB16) used for tag 4 lookup
30214Ch	REG_TOUCH_TAG4	8	r/o	-	Touch-screen tag result 4
302150h	REG_TOUCH_TRANSFORM_A	32	r/w	00010000h	Touch-screen transform coefficient (s15.16)
302154h	REG_TOUCH_TRANSFORM_B	32	r/w	00000000h	Touch-screen transform coefficient (s15.16)
302158h	REG_TOUCH_TRANSFORM_C	32	r/w	00000000h	Touch-screen transform coefficient (s15.16)
30215Ch	REG_TOUCH_TRANSFORM_D	32	r/w	00000000h	Touch-screen transform coefficient (s15.16)
302160h	REG_TOUCH_TRANSFORM_E	32	r/w	00010000h	Touch-screen transform coefficient (s15.16)
302164h	REG_TOUCH_TRANSFORM_F	32	r/w	00000000h	Touch-screen transform coefficient (s15.16)
302168h	REG_TOUCH_CONFIG	16	r/w	8381h (BT816) 0381h (BT815)	Touch configuration. RTP/CTP select RTP: short-circuit, sample clocks CTP: I2C address, CTPM type, low-power mode, touch host mode
30216Ch	REG_CTOUCH_TOUCH4_X	16	r/o	-	Extended mode: touch-screen screen X data for touch 4
302170h	REG_EHOST_TOUCH_ACK	4	r/w	0	Touch host mode: acknowledgement
302174h	REG_BIST_EN	1	r/w	0	BIST memory mapping enable
302178h-302187Ch	Reserved	-	-	-	Reserved
302180h	REG_TRIM	5	r/w	0	Internal relaxation clock trimming
302184h	REG_ANA_COMP	8	r/w	0	Analogue control register

Address (hex)	Register Name	Bits	r/w	Reset value	Description
302188h	REG_SPI_WIDTH	3	r/w	0	QSPI bus width setting Bit [2]: extra dummy cycle on read Bit [1:0]: bus width (0=1-bit, 1=2-bit, 2=4-bit)
30218Ch	REG_TOUCH_DIRECT_XY REG_CTOUCH_TOUCH2_XY	32	r/o	-	Compatibility mode: Touch screen direct (x-MSB16; y-LSB16) conversions Extended mode: touch-screen screen data for touch 2 (x-MSB16; y-LSB16)
302190h	REG_TOUCH_DIRECT_Z1Z2 REG_CTOUCH_TOUCH3_XY	32	r/o	-	Compatibility mode: Touch screen direct (z1-MSB16; z2-LSB16) conversions Extended mode: touch-screen screen data for touch 3 (x-MSB16; y-LSB16)
302194h-302560h	Reserved	-	-	-	Reserved
302564h	REG_DATESTAMP	128	r/o	-	Stamp date code
302574h	REG_CMDB_SPACE	12	r/w	FFCh	Command DL (bulk) space available
302578h	REG_CMDB_WRITE	32	w/o	0	Command DL (bulk) write
30257Ch	REG_ADAPTIVE_FRAMERATE	1	r/w	1	Reduce frame rate during complex drawing
3025ECh	REG_PLAYBACK_PAUSE	1	r/w	0	Audio playback pause
3025F0h	REG_FLASH_STATUS	2	r/w	0	Flash status

Table 5-2 Overview of BT815/6 Registers

Note: All register addresses are 4-byte aligned. The value in the “Bits” column refers to the number of valid bits from bit 0 unless otherwise specified; other bits are reserved.

5.2 Chip ID

The BT815/6 Chip ID can be read at memory location 0C0000h – 0C0003h. The reset values of these bytes are:

- 0C0000h: 08h
- 0C0001h: 15h (BT815), 16h(BT816)
- 0C0002h: 01h
- 0C0003h: 00h

Note that the Chip ID location can be over-written by software.

6 Devices Characteristics and Ratings

6.1 Absolute Maximum Ratings

The absolute maximum ratings for the BT815/6 devices are as follows. These are in accordance with the Absolute Maximum Rating System (IEC 60134). Exceeding these may cause permanent damage to the device.

Parameter	Value	Unit
Storage Temperature	-65 to +150	°C
Floor Life (Out of Bag) At Factory Ambient (30°C / 60% Relative Humidity)	168 (IPC/JEDEC J-STD-033A MSL Level 3 Compliant)*	Hours
Ambient Temperature (Power Applied)	-40 to +85	°C
VCC Supply Voltage	0 to +4	V
VCCIO Supply Voltage	0 to +4	V
DC Input Voltage	-0.5 to + (VCCIO + 0.3)	V

Table 6-1 Absolute Maximum Ratings

* If the devices are stored out of the packaging, beyond this time limit, the devices should be baked before use. The devices should be ramped up to a temperature of +125°C and baked for up to 17 hours.

6.2 ESD and Latch-up Specifications

Description	Specification
Human Body Mode (HBM)	> ± 2kV
Machine mode (MM)	> ± 200V
<u>Latch-up</u>	<u>> ± 200mA</u>

Table 6-2 ESD and Latch-Up Specifications

6.3 DC Characteristics

Parameter	Description	Minimum	Typical	Maximum	Units	Conditions
VCCIO1/ VCCIO2/VCC IO3	VCCIO operating supply voltage	1.62	1.80	1.98	V	Normal Operation
		2.25	2.50	2.75	V	
		2.97	3.30	3.63	V	

Parameter	Description	Minimum	Typical	Maximum	Units	Conditions
VCC/VCCA	VCC operating supply voltage	2.97	3.30	3.63	V	Normal Operation
Icc1	Power Down current	-	0.2	-	mA	Power down mode
Icc2	Sleep current	-	0.6	-	mA	Sleep Mode
Icc3	Standby current	-	3	-	mA	Standby Mode
Icc4	Operating current	-	22	-	mA	Normal Operation

Table 6-3 Operating Voltage and Current

Parameter	Description	Minimum	Typical	Maximum	Units	Conditions
Voh	Output Voltage High	VCCIO-0.4	-	-	V	Ioh=5mA
Vol	Output Voltage Low	-	-	0.4	V	Iol=5mA
Vih	Input High Voltage	2.0	-	-	V	
Vil	Input Low Voltage	-	-	0.8	V	
Vth	Schmitt Hysteresis Voltage	0.22	-	0.3	V	
Iin	Input leakage current	-10	-	10	uA	Vin = VCCIO or 0
Ioz	Tri-state output leakage current	-10	-	10	uA	Vin = VCCIO or 0
Rpu	Pull-up resistor	-	42	-	kΩ	
Rpd	Pull-down resistor	-	44	-	kΩ	

Table 6-4 Digital I/O Pin Characteristics (VCCIO = +3.3V)

Parameter	Description	Minimum	Typical	Maximum	Units	Conditions
Voh	Output Voltage High	VCCIO-0.4	-	-	V	Ioh=5mA
Vol	Output Voltage Low	-	-	0.4	V	Iol=5mA
Vih	Input High Voltage	1.7	-	-	V	-
Vil	Input Low Voltage	-	-	0.7	V	-

Vth	Schmitt Hysteresis Voltage	0.2	-	0.3	V	-
Iin	Input leakage current	-10	-	10	uA	Vin = VCCIO or 0
Ioz	Tri-state output leakage current	-10	-	10	uA	Vin = VCCIO or 0
Rpu	Pull-up resistor	-	57	-	kΩ	
Rpd	Pull-down resistor	-	59	-	kΩ	

Table 6-5 Digital I/O Pin Characteristics (VCCIO = +2.5V)

Parameter	Description	Minimum	Typical	Maximum	Units	Conditions
Voh	Output Voltage High	VCCIO-0.4	-	-	V	Ioh=5mA
Vol	Output Voltage Low	-	-	0.4	V	Iol=5mA
Vih	Input High Voltage	1.2	-	-	V	-
Vil	Input Low Voltage	-	-	0.6	V	-
Vth	Schmitt Hysteresis Voltage	0.17	-	0.3	V	-
Iin	Input leakage current	-10	-	10	uA	Vin = VCCIO or 0
Ioz	Tri-state output leakage current	-10	-	10	uA	Vin = VCCIO or 0
Rpu	Pull-up resistor	-	90	-	kΩ	
Rpd	Pull-down resistor	-	97	-	kΩ	

Table 6-6 Digital I/O Pin Characteristics (VCCIO = +1.8V)

Parameter	Description	Minimum	Typical	Maximum	Units	Conditions
Rsw-on	X-,X+,Y- and Y+ Drive On resistance	-	6	10	Ω	VCCIO=3.3V
		-	9	16	Ω	VCCIO=1.8V
Rsw-off	X-,X+,Y- and Y+ Drive Off resistance	10	-	-	MΩ	
Rpu	Touch sense pull up resistance	78	100	125	kΩ	
Vth+	Touch Detection rising-edge threshold on XP	1.59	-	2.04	V	VCCIO=3.3V
		0.58	-	0.68	V	VCCIO=1.8V

Parameter	Description	Minimum	Typical	Maximum	Units	Conditions
	pin					
Vth-	Touch Detection falling-edge threshold on XP pin	1.23	-	1.55	V	VCCIO=3.3V
		0.51	-	0.56	V	VCCIO=1.8V
RI	X-axis and Y-axis drive load resistance	200	-	-	Ω	

Table 6-7 Touch Sense Characteristics

6.4 AC Characteristics

6.4.1 System Clock and Reset

Parameter	Value			Units
	Minimum	Typical	Maximum	
Internal Relaxation Clock				
Trimmed frequency target	-	12	-	MHz
Trimmed frequency accuracy	-	±1.2	±6.0	%
Trimmed frequency variation over temperature and voltage	-	-	±4.0	%
Crystal				
Frequency	-	12.000	-	MHz
X1/X2 Capacitance	-	-	10	pF
External clock input				
Frequency	-	12.000	-	MHz
Duty cycle	45	50	55	%
Input voltage on X1/CLK	-	3.3	-	V
Reset				
Reset pulse on PD_N	5			ms

Table 6-8 System Clock Characteristics

6.4.2 SPI Interface Timing

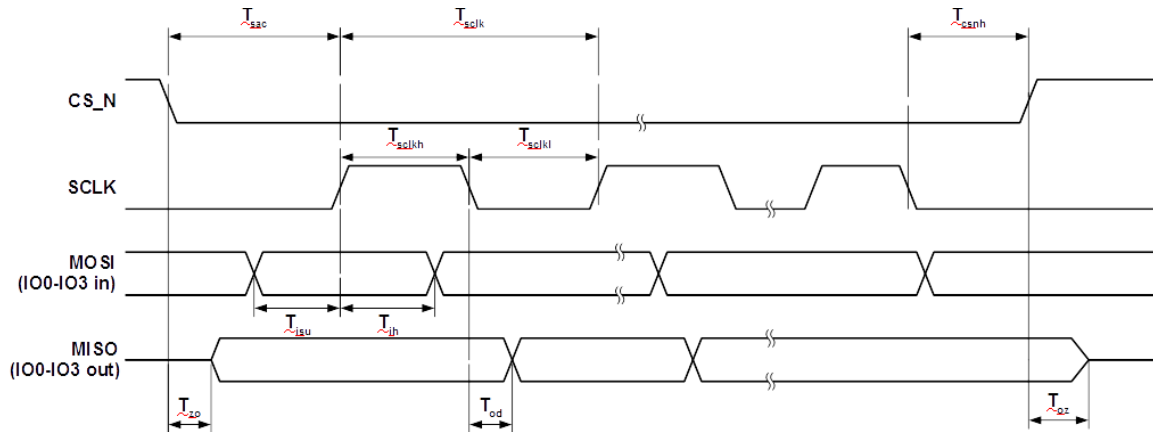

Figure 6-1 SPI Interface Timing

Parameter	Description	VCCIO=1.8V		VCCIO=2.5V		VCCIO=3.3V		Units
		Min	Max	Min	Max	Min	Max	
Tsclk	SPI clock period (SINGLE/DUAL mode)	33.3		33.3		33.3		ns
Tsclk	SPI clock period (QUAD mode)	33.3		33.3		33.3		ns
Tsckl	SPI clock low duration	13		13		13		ns
Tsclkh	SPI clock high duration	13		13		13		ns
Tsac	SPI access time	4		3.5		3		ns
Tisu	Input Setup	4		3.5		3		ns
Tih	Input Hold	0		0		0		ns
Tzo	Output enable delay		16		13		11	ns
Toz	Output disable delay		13		11		10	ns
Tod	Output data delay		15		12		11	ns
Tcsnh	CSN hold time	0		0		0		ns

Table 6-9 SPI Interface Timing Specifications

6.4.3 RGB Interface Timing

Parameter	Description	Value			Units
		Min	Typ	Max	
Tpclk	Pixel Clock period	13.9	27.8		ns
Tpclkdc	Pixel Clock duty cycle	40	50	60	%
Td	Output delay relative to PCLK rising edge (REG_PCLK_POL=0) or falling edge (REG_PCLK_POL=1). Applied for all the RGB output pins.			4	ns
Th	Output hold time relative to PCLK rising edge (REG_PCLK_POL=0) or falling edge (REG_PCLK_POL=1). Applied for all the RGB output pins.	0.5			ns

Table 6-10 RGB Interface Timing Characteristics

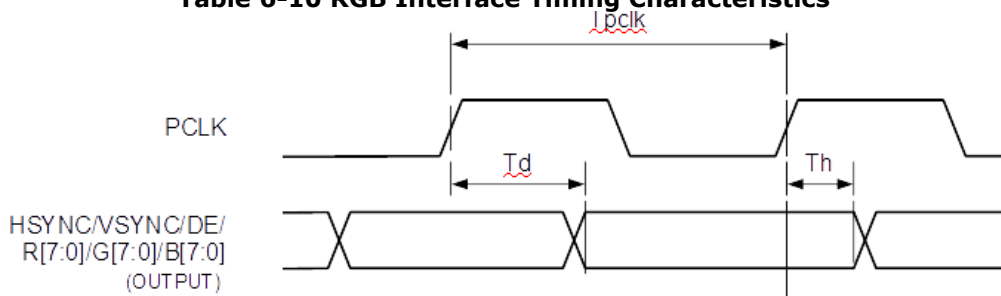

Figure 6-2 RGB Interface Timing

8 Package Parameters

The BT815/6 is available in VQFN-64 package. The package dimensions, markings and solder reflow profile for all packages are described in following sections.

8.1 Part Markings

8.1.1 Top Side



Notes:

1. YYWW = Date Code, where YY is year and WW is week number
2. BRT part number will be either BT815Q or BT816Q as per device selected.

8.1.2 Bottom Side

No markings should be placed on the bottom side.

8.2 VQFN-64 Package Dimensions

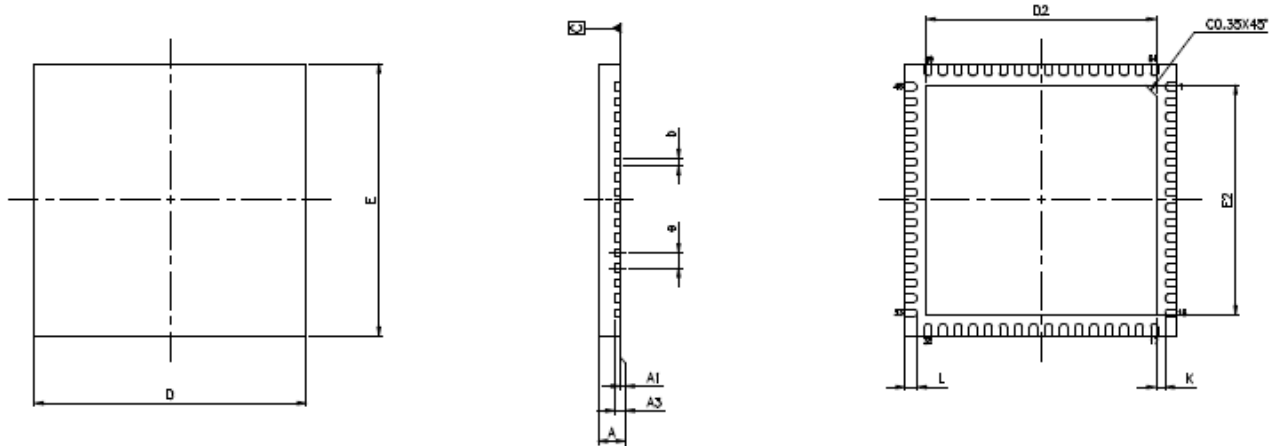

	A	A1	A3	b	D	E	D2	E2	e	L	K
MIN.	0.80	0.00		0.18			7.25	7.25		0.35	0.20
NOM.	0.85	0.02	0.20	0.25	9.00	9.00	7.30	7.30	0.50	0.40	
MAX.	0.90	0.05		0.30			7.35	7.35		0.45	

All dimensions are in millimetres (mm)

Figure 8-1 VQFN-64 Package Dimensions

8.3 Solder Reflow Profile

The recommended solder reflow profile for the package is shown in Figure 8-2.

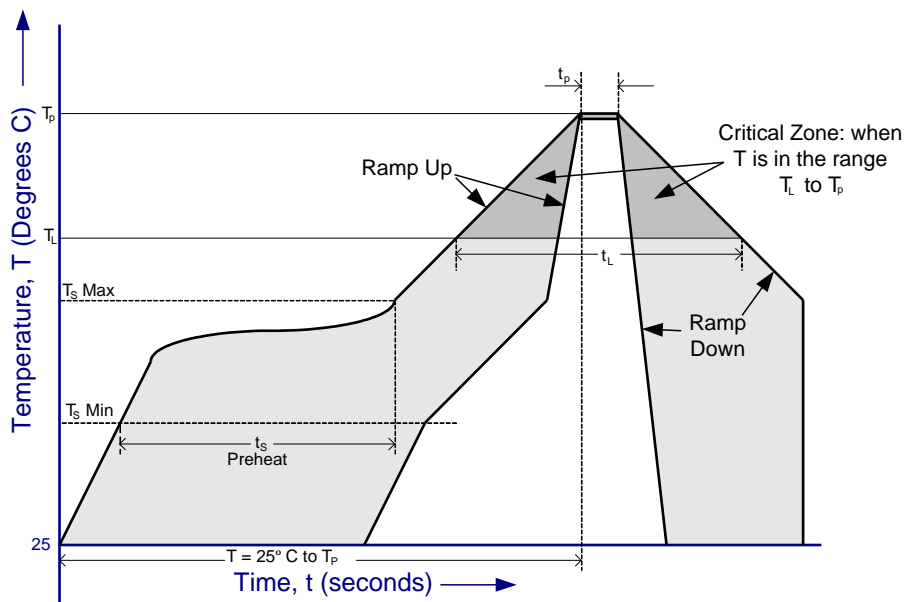

Figure 8-2 BT815/6 Solder Reflow Profile

The recommended values for the solder reflow profile are detailed in Figure 8-2. Values are shown for both a completely Pb free solder process (i.e. the BT815/6 is used with Pb free solder), and for a non-Pb free solder process (i.e. the BT815/6 is used with non-Pb free solder).

Profile Feature	Pb Free Solder Process	Non-Pb Free Solder Process
Average Ramp Up Rate (T_s to T_p)	3°C / second Max.	3°C / Second Max.
Preheat - Temperature Min (T_s Min.) - Temperature Max (T_s Max.) - Time (t_s Min to t_s Max)	150°C 200°C 60 to 120 seconds	100°C 150°C 60 to 120 seconds
Time Maintained Above Critical Temperature T_L : - Temperature (T_L) - Time (t_L)	217°C 60 to 150 seconds	183°C 60 to 150 seconds
Peak Temperature (T_p)	260°C	240°C
Time within 5°C of actual Peak Temperature (t_p)	20 to 40 seconds	20 to 40 seconds
Ramp Down Rate	6°C / second Max.	6°C / second Max.
Time for $T = 25^\circ\text{C}$ to Peak Temperature, T_p	8 minutes Max.	6 minutes Max.

Table 8-1 Reflow Profile Parameter Values

9 Contact Information

Head Quarters – Singapore

Bridgetek Pte Ltd
178 Paya Lebar Road, #07-03
Singapore 409030
Tel: +65 6547 4827
Fax: +65 6841 6071

E-mail (Sales) sales.apac@brtchip.com
E-mail (Support) support.apac@brtchip.com

Branch Office – Taipei, Taiwan

Bridgetek Pte Ltd, Taiwan Branch
2 Floor, No. 516, Sec. 1, Nei Hu Road, Nei Hu District
Taipei 114
Taiwan, R.O.C.
Tel: +886 (2) 8797 5691
Fax: +886 (2) 8751 9737

E-mail (Sales) sales.apac@brtchip.com
E-mail (Support) support.apac@brtchip.com

Branch Office - Glasgow, United Kingdom

Bridgetek Pte. Ltd.
Unit 1, 2 Seaward Place, Centurion Business Park
Glasgow G41 1HH
United Kingdom
Tel: +44 (0) 141 429 2777
Fax: +44 (0) 141 429 2758

E-mail (Sales) sales.emea@brtchip.com
E-mail (Support) support.emea@brtchip.com

Branch Office – Vietnam

Bridgetek VietNam Company Limited
Lutaco Tower Building, 5th Floor, 173A Nguyen Van
Troï,
Ward 11, Phu Nhuan District,
Ho Chi Minh City, Vietnam
Tel : 08 38453222
Fax : 08 38455222

E-mail (Sales) sales.apac@brtchip.com
E-mail (Support) support.apac@brtchip.com

Web Site

<http://brtchip.com/>

Distributor and Sales Representatives

Please visit the Sales Network page of the [Bridgetek Web site](#) for the contact details of our distributor(s) and sales representative(s) in your country.

System and equipment manufacturers and designers are responsible to ensure that their systems, and any Bridgetek Pte Ltd (BRT Chip) devices incorporated in their systems, meet all applicable safety, regulatory and system-level performance requirements. All application-related information in this document (including application descriptions, suggested Bridgetek devices and other materials) is provided for reference only. While Bridgetek has taken care to assure it is accurate, this information is subject to customer confirmation, and Bridgetek disclaims all liability for system designs and for any applications assistance provided by Bridgetek. Use of Bridgetek devices in life support and/or safety applications is entirely at the user's risk, and the user agrees to defend, indemnify and hold harmless Bridgetek from any and all damages, claims, suits or expense resulting from such use. This document is subject to change without notice. No freedom to use patents or other intellectual property rights is implied by the publication of this document. Neither the whole nor any part of the information contained in, or the product described in this document, may be adapted or reproduced in any material or electronic form without the prior written consent of the copyright holder. Bridgetek Pte Ltd, 178 Paya Lebar Road, #07-03, Singapore 409030. Singapore Registered Company Number: 201542387H.

Appendix A – References

Document References

- [BT81X Series Programming Guide](#)
- [AN_252_FT800_Audio_Primer](#)
- [AN_254_FT800_Designs_with_Visual_TFT](#)
- [AN_259_FT800_Example_with_8-bit_MCU](#)
- [AN_275_FT800_Example_with_Arduino](#)
- [AN_276_Audio_File_Conversion](#)
- [AN_277_FT800_Create_User_Defined_Font](#)
- [AN_281_FT800_Emulator_Library_User_Guide](#)
- [AN_291_FT800_Create_Multi-Language_Font](#)
- [AN_299_FT800_FT801_Internal_Clock_Trimming](#)
- [AN_303 - FT800 Image File Conversion](#)
- [AN_308_FT800_Example_with_an_8-bit_MCU](#)
- [AN_312_FT800_Example_with_ARM](#)
- [AN_314_FT800_Advanced_Techniques - Working with Bitmaps](#)
- [AN_318_Arduino_Library_for_FT800_Series](#)
- [AN_320_FT800_Example_with_PIC](#)
- [AN_327_EVE_Screen_Editor_Installation_Guide](#)
- [AN_336_FT8xx - Selecting an LCD Display](#)
- [FT800 Series Sample Application](#)
- [EVE Frequently Asked Questions](#)

Acronyms and Abbreviations

Terms	Description
ADPCM	Adaptive Differential Pulse Code Modulation
ASCII	American Standard Code for Information Interchange
ASTC	Adaptive Scalable Texture Compression
CTPM	Capacitive Touch Panel Module
CTSE	Capacitive Touch Screen Engine
EVE	Embedded Video Engine
HMI	Human Machine Interfaces
I ² C	Inter-Integrated Circuit
LCD	Liquid Crystal Display

LED	Light Emitting Diode
MCU	Micro Controller Unit
MPU	Micro Processor Unit
PCM	Pulse Code Modulation
PLL	Phased Locked Loop
PWM	Pulse Width Modulation
WVGA	Wide Video Graphics Array
ROM	Read Only Memory
SPI	Serial Peripheral Interface
VQFN	Very Thin Quad Flat Non-Leaded Package

Appendix B - List of Figures and Tables

List of Figures

Figure 2-1 BT815/6 Block Diagram	3
Figure 2-2 BT815/6 System Design Diagram	3
Figure 3-1 Pin Configuration BT815 VQFN-64(Top View)	7
Figure 3-2 Pin Configuration BT816 VQFN-64 (Top View)	7
Figure 4-1 SPI Master and Slave in the Master Read Case.....	13
Figure 4-2 Single/Dual SPI Interface connection	13
Figure 4-3 Quad SPI Interface connection	14
Figure 4-4 Internal relaxation oscillator connection	20
Figure 4-5 Crystal Oscillator Connection	20
Figure 4-6 External Clock Input	20
Figure 4-6 Flash Interface States	26
Figure 4-7 RGB Timing Waveforms.....	29
Figure 4-8 Resistive Touch Screen Connection.....	33
Figure 4-9 Touch Screen Connection	34
Figure 4-10 Touch Host Mode Connections.....	36
Figure 4-11 Internal Regulator	38
Figure 4-12 Power State Transition	39
Figure 6-1 SPI Interface Timing	52
Figure 6-2 RGB Interface Timing.....	53
Figure 7-1 BT815 application circuit	54
Figure 7-2 BT816 application circuit	55
Figure 8-1 VQFN-64 Package Dimensions	57
Figure 8-2 BT815/6 Solder Reflow Profile.....	57

List of Tables

Table 3-1 BT815/6 Pin Description	11
Table 4-1 QSPI Channel Selection.....	12
Table 4-2 Host Memory Read Transaction	14
Table 4-3 Host Memory Write Transaction.....	15
Table 4-4 Host Command Transaction	15
Table 4-5 Host Command List	19
Table 4-6 Interrupt Flags bit assignment	19
Table 4-7 Font Table Format	22
Table 4-8 ROM Font Table.....	23

Table 4-9 ROM font ASCII character width in pixels.....	25
Table 4-10 ROM Font Extended ASCII Characters	25
Table 4-11 RGB PCLK Frequency.....	27
Table 4-12 REG_SWIZZLE RGB Pins Mapping	28
Table 4-13 Registers for RGB Horizontal and Vertical Timings.....	28
Table 4-14 Output Drive Current Selection.....	30
Table 4-15 Sound Effect	31
Table 4-16 MIDI Note Effect.....	32
Table 4-17 Resistive Touch Controller Operating Mode	33
Table 4-18 Capacitive Touch Controller Operating Mode	34
Table 4-19 Registers for Touch Host Mode	36
Table 4-20 Power Supply	37
Table 4-21 Pin Status.....	41
Table 5-1 BT815/6 Memory Map	42
Table 5-2 Overview of BT815/6 Registers	47
Table 6-1 Absolute Maximum Ratings.....	48
Table 6-2 ESD and Latch-Up Specifications	48
Table 6-3 Operating Voltage and Current.....	49
Table 6-4 Digital I/O Pin Characteristics (VCCIO = +3.3V)	49
Table 6-5 Digital I/O Pin Characteristics (VCCIO = +2.5V)	50
Table 6-6 Digital I/O Pin Characteristics (VCCIO = +1.8V)	50
Table 6-7 Touch Sense Characteristics	51
Table 6-8 System Clock Characteristics	51
Table 6-9 SPI Interface Timing Specifications.....	52
Table 6-10 RGB Interface Timing Characteristics	53
Table 8-1 Reflow Profile Parameter Values	58

Appendix C - Revision History

Document Title: BT81X (815/6) Advanced Embedded Video Engine Datasheet
Document Reference No.: BRT_000220
Clearance No.: BRT#126
Product Page: <http://brtchip.com/product>
Document Feedback: [Send Feedback](#)

Revision	Changes	Date
Draft	Initial Release	2018-02-22
1.0	Added application circuit / internal clock function and parameters	2018-08-15

Looking for pricing, stock, or lifecycle information?

Click below to explore more details on WIN SOURCE:

- [View BT816Q-R on WIN SOURCE](#)
- [Bridgetek Pte Ltd. Information](#)

Optimize Your Supply Chain with WIN SOURCE Solutions

- ✓ Global Sourcing Solution
- ✓ Obsolete Management
- ✓ Cost Control Management
- ✓ Shortage Management
- ✓ Alternative Solution
- ✓ Excess Inventory Management