

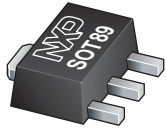

**THE DATASHEET OF
BGA3012,115**





BGA3012

1 GHz 12 dB gain wideband amplifier MMIC

Rev. 3 — 26 September 2013

Product data sheet

1. Product profile

1.1 General description

The BGA3012 MMIC is a wideband amplifier with internal biasing. It is designed specifically for high linearity CATV line extenders and drop amplifiers over a frequency range of 5 MHz to 1006 MHz. The LNA is housed in a lead free 3-pin SOT89 package.

1.2 Features and benefits

- Internally biased
- Flat gain
- High linearity with an IP_{3O} of 40 dBm and an IP_{2O} of 60 dBm
- Noise figure of 3.1 dB
- 75 Ω input and output impedance
- Operating from 5 V to 8 V supply

1.3 Applications

- General wideband amplifiers.
- CATV return amplifier; frequency ranges of 5 MHz to 300 MHz.
- CATV infrastructure network driver in optical nodes (FTTx), distribution amplifiers, trunk amplifiers and line extenders in the frequency range from 40 MHz to 1006 MHz.
- The product is ideally suited for applications as drop amplifiers in CATV distribution systems such as FTTH

1.4 Quick reference data

Table 1. Quick reference data

Bandwidth 40 MHz to 1006 MHz; $T_{amb} = 25\text{ }^{\circ}\text{C}$; typical values at $V_{CC} = 8\text{ V}$; $Z_S = Z_L = 75\ \Omega$; $R1 = 100\ \Omega$; $R2 = 300\ \Omega$.

| Symbol | Parameter | Conditions | Min | Typ | Max | Unit |
|---------------|---------------------------------------|----------------------|--------|-----|-----|--------------------|
| V_{CC} | supply voltage | RF input AC coupled | 7.6 | 8 | 8.4 | V |
| $I_{CC(tot)}$ | total supply current | | - | 110 | 125 | mA |
| T_{amb} | ambient temperature | | -40 | - | +85 | $^{\circ}\text{C}$ |
| NF | noise figure | $f = 500\text{ MHz}$ | - | 3.1 | 3.6 | dB |
| $P_{L(1dB)}$ | output power at 1 dB gain compression | | 21.5 | 23 | - | dBm |
| IP_{3O} | output third-order intercept point | | [1] 36 | 40 | - | dBm |
| IP_{2O} | output second-order intercept point | | [2] - | 60 | - | dBm |

- [1] The fundamental frequencies (f_1) and (f_2) lay between 40 MHz and 1006 MHz. The intermodulation product (IM3) is $2 \times f_2 - f_1$, where $f_2 = f_1 \pm 6\text{ MHz}$. Input power $P_i = -20\text{ dBm}$.
- [2] The fundamental frequencies (f_1) and (f_2) lay between 40 MHz and 1006 MHz. The intermodulation product (IM2) is $|f_2 - f_1|$, with $40\text{ MHz} < |f_1 - f_2| < 1006\text{ MHz}$. Input power $P_i = -20\text{ dBm}$.



2. Pinning information

Table 2. Pinning

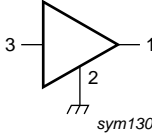
| Pin | Description | Simplified outline | Graphic symbol |
|-----|--------------------|--------------------|---|
| 1 | RF_OUT and biasing | [1] |  |
| 2 | GND | [2] | |
| 3 | RF_IN | [1] | |

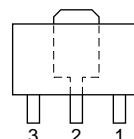

[1] This pin is DC-coupled and requires an external DC-blocking capacitor.

[2] The center metal base of the SOT89 also functions as heatsink for the power amplifier.

3. Ordering information

Table 3. Ordering information

| Type number | Package | | Version |
|-------------|---------|--|---------|
| | Name | Description | |
| BGA3012 | - | plastic surface-mounted package; exposed die pad for good heat transfer; 3 leads | SOT89 |
| OM7858 | EVB | 1 GHz 12 dB gain wideband amplifier application | - |
| OM7862 | EVB | 5 MHz to 300 MHz 12 dB reverse amplifier application | - |
| OM7866 | EVB | 40 MHz to 1006 MHz push-pull amplifier application | - |

4. Marking

Table 4. Marking codes

| Type number | Marking code | Description |
|-------------|--------------|-----------------------|
| BGA3012 | *6W | * = W : made in China |

5. Limiting values

Table 5. Limiting values

In accordance with the Absolute Maximum Rating System (IEC 60134).

| Symbol | Parameter | Conditions | Min | Max | Unit |
|-----------|---------------------------------|--|------|------|------|
| V_{CC} | supply voltage | RF input AC coupled | -0.6 | +15 | V |
| P_i | input power | single tone | - | 20 | dBm |
| T_{stg} | storage temperature | | -65 | +150 | °C |
| T_j | junction temperature | | - | 150 | °C |
| T_{amb} | ambient temperature | | -40 | +85 | °C |
| V_{ESD} | electrostatic discharge voltage | Human Body Model (HBM); According JEDEC standard 22-A114E | 2 | - | kV |
| | | Charged Device Model (CDM); According JEDEC standard 22-C101B | 2 | - | kV |

6. Thermal characteristics

Table 6. Thermal characteristics

| Symbol | Parameter | Conditions | Typ | Unit |
|----------------|--|------------|-----|------|
| $R_{th(j-sp)}$ | thermal resistance from junction to solder point | | 40 | K/W |

7. Characteristics

7.1 Forward application

Table 7. Characteristics at $V_{CC} = 8\text{ V}$

Bandwidth 40 MHz to 1006 MHz; $T_{amb} = 25\text{ }^{\circ}\text{C}$; typical values at $V_{CC} = 8\text{ V}$; $Z_S = Z_L = 75\ \Omega$; $R1 = 100\ \Omega$; $R2 = 300\ \Omega$.

| Symbol | Parameter | Conditions | Min | Typ | Max | Unit |
|---------------|---------------------------------------|-----------------------|------|-----|-----|------|
| V_{CC} | supply voltage | RF input AC coupled | 7.6 | 8 | 8.4 | V |
| $I_{CC(tot)}$ | total supply current | | - | 110 | 125 | mA |
| $ S_{21} ^2$ | insertion power gain | | 11 | 12 | 13 | dB |
| SL_{sl} | slope straight line | | - | 0.5 | - | dB |
| FL | flatness of frequency response | | - | 0.5 | - | dB |
| NF | noise figure | $f = 50\text{ MHz}$ | - | 3.0 | 3.5 | dB |
| | | $f = 500\text{ MHz}$ | - | 3.1 | 3.6 | dB |
| | | $f = 1000\text{ MHz}$ | - | 3.4 | 3.9 | dB |
| RL_{in} | input return loss | $f = 50\text{ MHz}$ | - | 22 | - | dB |
| | | $f = 500\text{ MHz}$ | - | 27 | - | dB |
| | | $f = 1000\text{ MHz}$ | - | 29 | - | dB |
| RL_{out} | output return loss | $f = 50\text{ MHz}$ | - | 21 | - | dB |
| | | $f = 500\text{ MHz}$ | - | 22 | - | dB |
| | | $f = 1000\text{ MHz}$ | - | 15 | - | dB |
| $P_{L(1dB)}$ | output power at 1 dB gain compression | | 21.5 | 23 | - | dBm |
| $IP3_O$ | output third-order intercept point | [1] | 36 | 40 | - | dBm |
| $IP2_O$ | output second-order intercept point | [2] | - | 60 | - | dBm |
| CTB | composite triple beat | [3] | - | -75 | - | dBc |
| CSO | composite second-order distortion | [3] | - | -60 | - | dBc |

[1] The fundamental frequencies (f_1) and (f_2) lay between 40 MHz and 1006 MHz. The intermodulation product (IM3) is $2 \times f_2 - f_1$, where $f_2 = f_1 \pm 6\text{ MHz}$. Input power $P_i = -20\text{ dBm}$.

[2] The fundamental frequencies (f_1) and (f_2) lay between 40 MHz and 1006 MHz. The intermodulation product (IM2) is $|f_2 - f_1|$, with $40\text{ MHz} < |f_1 - f_2| < 1006\text{ MHz}$. Input power $P_i = -20\text{ dBm}$.

[3] Measured with 132 NTSC channels $V_O = 30\text{ dBmV}$.

Table 8. Characteristics at $V_{CC} = 5\text{ V}$

Bandwidth 40 MHz to 1006 MHz; $T_{amb} = 25\text{ }^{\circ}\text{C}$; typical values at $V_{CC} = 5\text{ V}$; $Z_S = Z_L = 75\text{ }\Omega$;
 $R1 = 100\text{ }\Omega$; $R2 = 300\text{ }\Omega$.

| Symbol | Parameter | Conditions | Min | Typ | Max | Unit |
|----------------------|---------------------------------------|---------------------|------|-----|------|------|
| V_{CC} | supply voltage | RF input AC coupled | 4.75 | 5 | 5.25 | V |
| $I_{CC(\text{tot})}$ | total supply current | | - | 70 | 85 | mA |
| $ S_{21} ^2$ | insertion power gain | | - | 12 | - | dB |
| SL_{sl} | slope straight line | | - | 0.5 | - | dB |
| FL | flatness of frequency response | | - | 0.5 | - | dB |
| NF | noise figure | f = 50 MHz | - | 2.9 | - | dB |
| | | f = 500 MHz | - | 2.9 | - | dB |
| | | f = 1000 MHz | - | 3.2 | - | dB |
| RL_{in} | input return loss | f = 50 MHz | - | 22 | - | dB |
| | | f = 500 MHz | - | 25 | - | dB |
| | | f = 1000 MHz | - | 25 | - | dB |
| RL_{out} | output return loss | f = 50 MHz | - | 22 | - | dB |
| | | f = 500 MHz | - | 22 | - | dB |
| | | f = 1000 MHz | - | 12 | - | dB |
| $P_{L(1\text{dB})}$ | output power at 1 dB gain compression | | - | 18 | - | dBm |
| $IP3_O$ | output third-order intercept point | | [1] | 36 | - | dBm |
| $IP2_O$ | output second-order intercept point | | [2] | 54 | - | dBm |
| CTB | composite triple beat | | [3] | -70 | - | dBc |
| CSO | composite second-order distortion | | [3] | -54 | - | dBc |

[1] The fundamental frequencies (f_1) and (f_2) lay between 40 MHz and 1006 MHz. The intermodulation product (IM3) is $2 \times f_2 - f_1$, where $f_2 = f_1 \pm 6\text{ MHz}$. Input power $P_i = -20\text{ dBm}$.

[2] The fundamental frequencies (f_1) and (f_2) lay between 40 MHz and 1006 MHz. The intermodulation product (IM2) is $|f_2 - f_1|$, with $40\text{ MHz} < |f_1 - f_2| < 1006\text{ MHz}$. Input power $P_i = -20\text{ dBm}$.

[3] Measured with 132 NTSC channels $V_O = 30\text{ dBmV}$.

7.2 Return application

Table 9. Characteristics at $V_{CC} = 8\text{ V}$

Bandwidth 5 MHz to 300 MHz; $T_{amb} = 25\text{ }^{\circ}\text{C}$; typical values at $V_{CC} = 8\text{ V}$; $Z_S = Z_L = 75\ \Omega$; $R1 = 100\ \Omega$; $R2 = 300\ \Omega$.

| Symbol | Parameter | Conditions | Min | Typ | Max | Unit |
|----------------------|---------------------------------------|----------------------|-----|------|-----|------|
| V_{CC} | supply voltage | RF input AC coupled | 7.6 | 8 | 8.4 | V |
| $I_{CC(\text{tot})}$ | total supply current | | - | 110 | 125 | mA |
| $ S_{21} ^2$ | insertion power gain | | - | 12 | - | dB |
| SL_{sl} | slope straight line | | - | 0.5 | - | dB |
| FL | flatness of frequency response | | - | 0.5 | - | dB |
| NF | noise figure | $f = 50\text{ MHz}$ | - | 3.0 | - | dB |
| RL_{in} | input return loss | $f = 5\text{ MHz}$ | - | 18.5 | - | dB |
| | | $f = 100\text{ MHz}$ | - | 18.5 | - | dB |
| | | $f = 200\text{ MHz}$ | - | 18.5 | - | dB |
| | | $f = 300\text{ MHz}$ | - | 18.5 | - | dB |
| RL_{out} | output return loss | $f = 5\text{ MHz}$ | - | 18.5 | - | dB |
| | | $f = 100\text{ MHz}$ | - | 18.5 | - | dB |
| | | $f = 200\text{ MHz}$ | - | 18.5 | - | dB |
| | | $f = 300\text{ MHz}$ | - | 18.5 | - | dB |
| $P_{L(1\text{dB})}$ | output power at 1 dB gain compression | | - | 23 | - | dBm |
| $IP3_O$ | output third-order intercept point | [1] | - | 40 | - | dBm |
| $IP2_O$ | output second-order intercept point | [2] | - | 60 | - | dBm |

[1] The fundamental frequencies (f_1) and (f_2) lay between 5 MHz and 300 MHz. The intermodulation product (IM3) is $2 \times f_2 - f_1$, where $f_2 = f_1 \pm 6\text{ MHz}$. Input power $P_i = -20\text{ dBm}$.

[2] The fundamental frequencies (f_1) and (f_2) lay between 5 MHz and 300 MHz. The intermodulation product (IM2) is $|f_2 - f_1|$, with $40\text{ MHz} < |f_1 - f_2| < 300\text{ MHz}$. Input power $P_i = -20\text{ dBm}$.

Table 10. Characteristics at $V_{CC} = 5\text{ V}$

Bandwidth 5 MHz to 300 MHz; $T_{amb} = 25\text{ }^\circ\text{C}$; typical values at $V_{CC} = 5\text{ V}$; $Z_S = Z_L = 75\text{ }\Omega$; $R1 = 100\text{ }\Omega$; $R2 = 300\text{ }\Omega$.

| Symbol | Parameter | Conditions | Min | Typ | Max | Unit | |
|---------------|---------------------------------------|----------------------|------|------|------|------|-----|
| V_{CC} | supply voltage | RF input AC coupled | 4.75 | 5 | 5.25 | V | |
| $I_{CC(tot)}$ | total supply current | | - | 70 | 85 | mA | |
| $ S_{21} ^2$ | insertion power gain | | - | 12 | - | dB | |
| SL_{sl} | slope straight line | | - | 0.5 | - | dB | |
| FL | flatness of frequency response | | - | 0.5 | - | dB | |
| NF | noise figure | $f = 50\text{ MHz}$ | - | 2.9 | - | dB | |
| RL_{in} | input return loss | $f = 5\text{ MHz}$ | - | 18.5 | - | dB | |
| | | $f = 100\text{ MHz}$ | - | 18.5 | - | dB | |
| | | $f = 200\text{ MHz}$ | - | 18.5 | - | dB | |
| | | $f = 300\text{ MHz}$ | - | 18.5 | - | dB | |
| RL_{out} | output return loss | $f = 5\text{ MHz}$ | - | 18.5 | - | dB | |
| | | $f = 100\text{ MHz}$ | - | 18.5 | - | dB | |
| | | $f = 200\text{ MHz}$ | - | 18.5 | - | dB | |
| | | $f = 300\text{ MHz}$ | - | 18.5 | - | dB | |
| $P_{L(1dB)}$ | output power at 1 dB gain compression | | - | 17 | - | dBm | |
| $IP3_O$ | output third-order intercept point | | [1] | - | 40 | - | dBm |
| $IP2_O$ | output second-order intercept point | | [2] | - | 55 | - | dBm |

- [1] The fundamental frequencies (f_1) and (f_2) lay between 5 MHz and 300 MHz. The intermodulation product (IM3) is $2 \times f_2 - f_1$, where $f_2 = f_1 \pm 6\text{ MHz}$. Input power $P_i = -20\text{ dBm}$.
- [2] The fundamental frequencies (f_1) and (f_2) lay between 5 MHz and 300 MHz. The intermodulation product (IM2) is $|f_2 - f_1|$, with $40\text{ MHz} < |f_1 - f_2| < 300\text{ MHz}$. Input power $P_i = -20\text{ dBm}$.

8. Application information

8.1 Forward application 40 MHz to 1006 MHz

The BGA3012 can be used in other applications. Please contact your local sales representative for more information. Application notes are available on the NXP website.

8.1.1 Forward application circuit

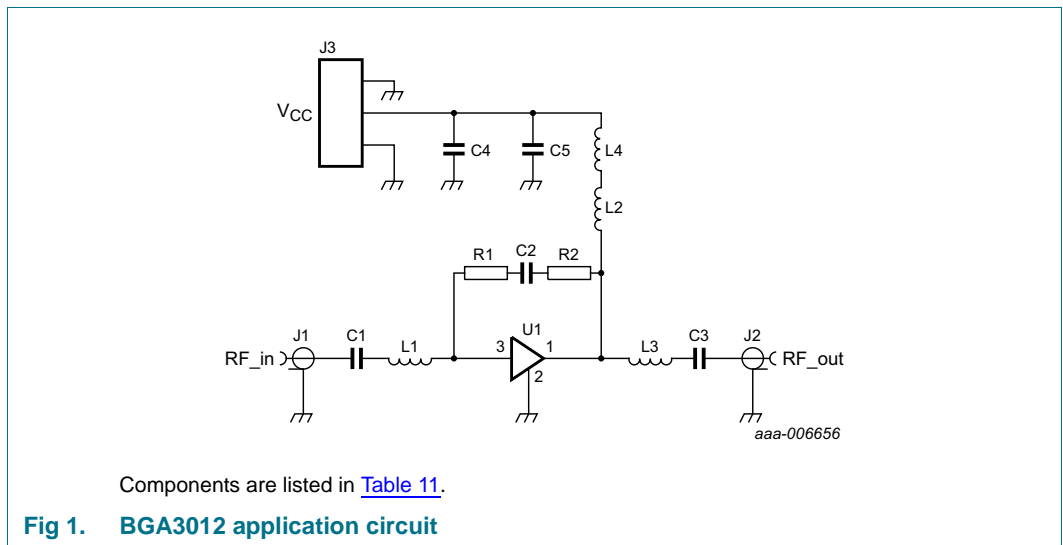

All control and supply lines must be decoupled properly. The decoupling capacitors must be placed as close to the device as possible.

8.1.2 Forward application circuit board layout

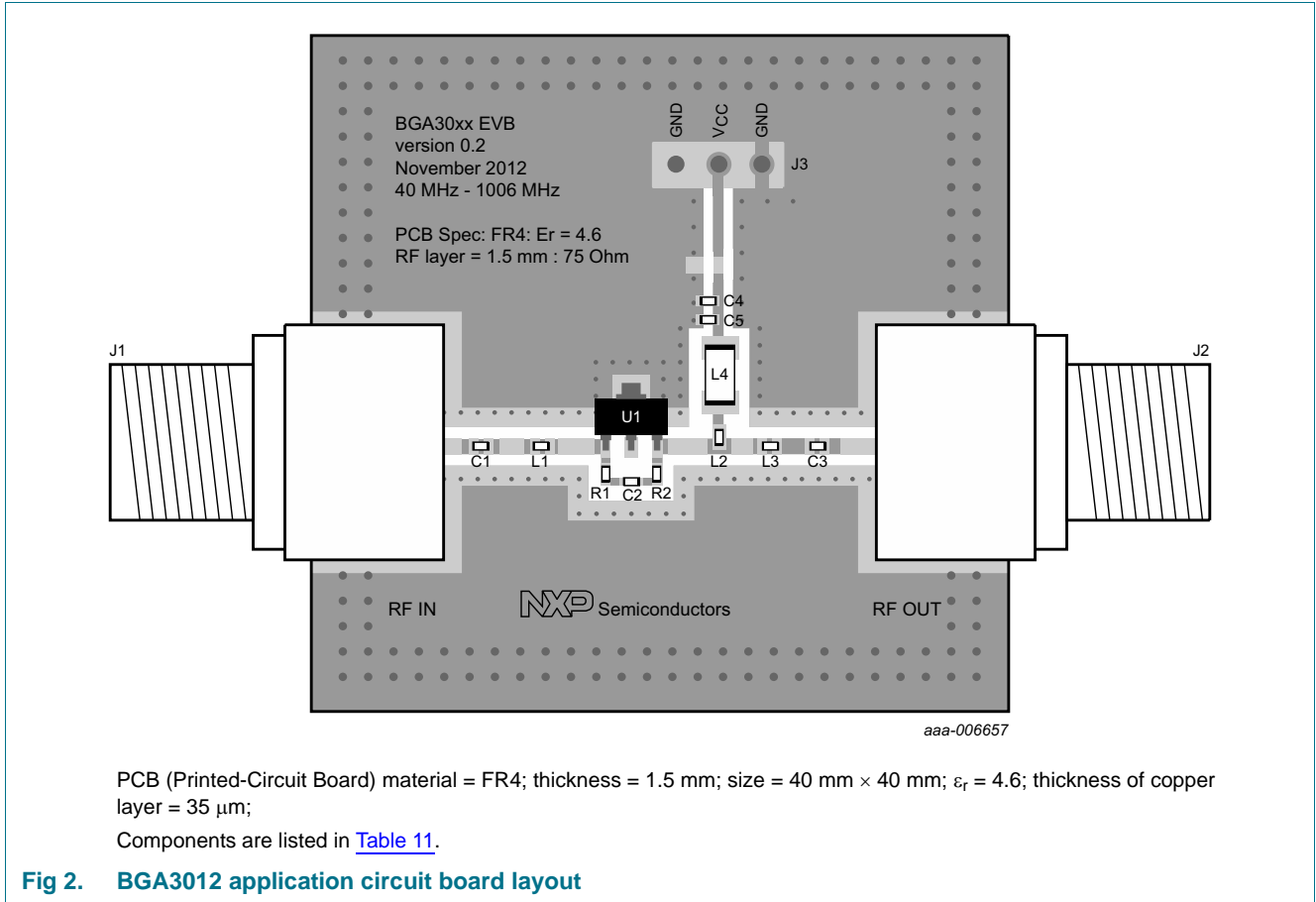

Table 11. List of components

See [Figure 1](#) and [Figure 2](#).

| Component | Description | Value | Size | Remarks |
|----------------|--------------|--------------|----------|--|
| C1, C2, C3, C4 | capacitor | 10 nF | SMD 0402 | Murata GRM155R71E103KA01D or capacitor of same quality |
| C5 | capacitor | 100 pF | SMD 0402 | Murata GRM155C1H101JZ01D or capacitor of same quality |
| J1, J2 | F-connector | 75 Ω | - | Bomar 861V509ER6 or F-connector of same quality |
| J3 | header 3-way | - | - | Molex 90121-0763 or header of the same quality |
| L1, L3 | inductor | 3.9 nH | SMD 0402 | Murata LQG15HS3N9S02D or inductor of same quality |
| L2 | choke | - | SMD 0603 | Murata BLM18HD182SN1D or choke of same quality |
| L4 | inductor | 880 nH | SMD 1206 | Murata LQH31HNR88K03L or inductor of same quality |
| R1 | resistor | 100 Ω | SMD 0402 | Yageo RC0402FR-07100RL or resistor of same quality |
| R2 | resistor | 300 Ω | SMD 0402 | Yageo RC0402FR-07300RL or resistor of same quality |
| U1 | BGA3012 | - | - | NXP |

8.2 Return application 5 MHz to 300 MHz

The BGA3012 can be used in other applications. Please contact your local sales representative for more information. Application notes are available on the NXP website.

8.2.1 Return application circuit

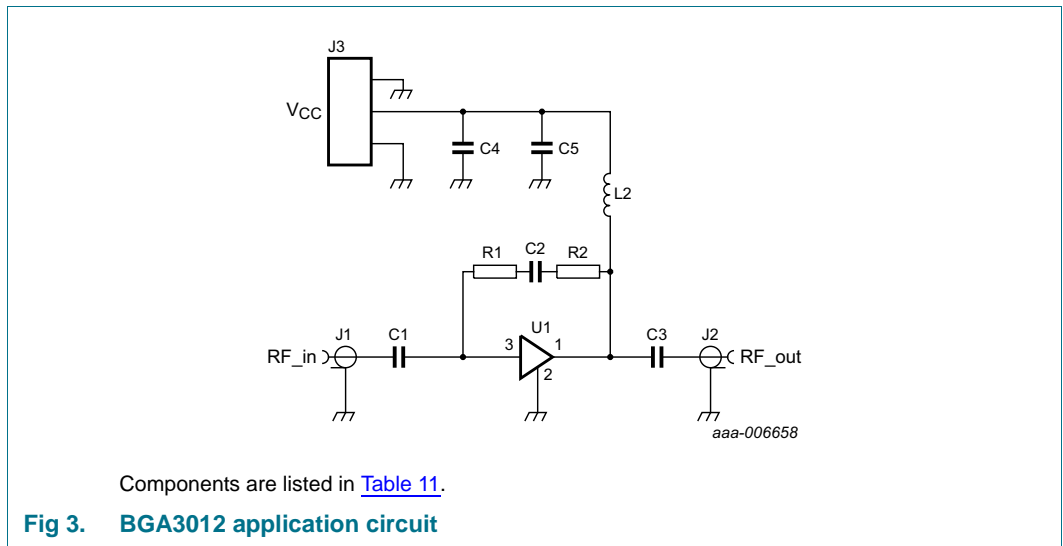

All control and supply lines must be decoupled properly. The decoupling capacitors must be placed as close to the device as possible.

8.2.2 Return application circuit board layout

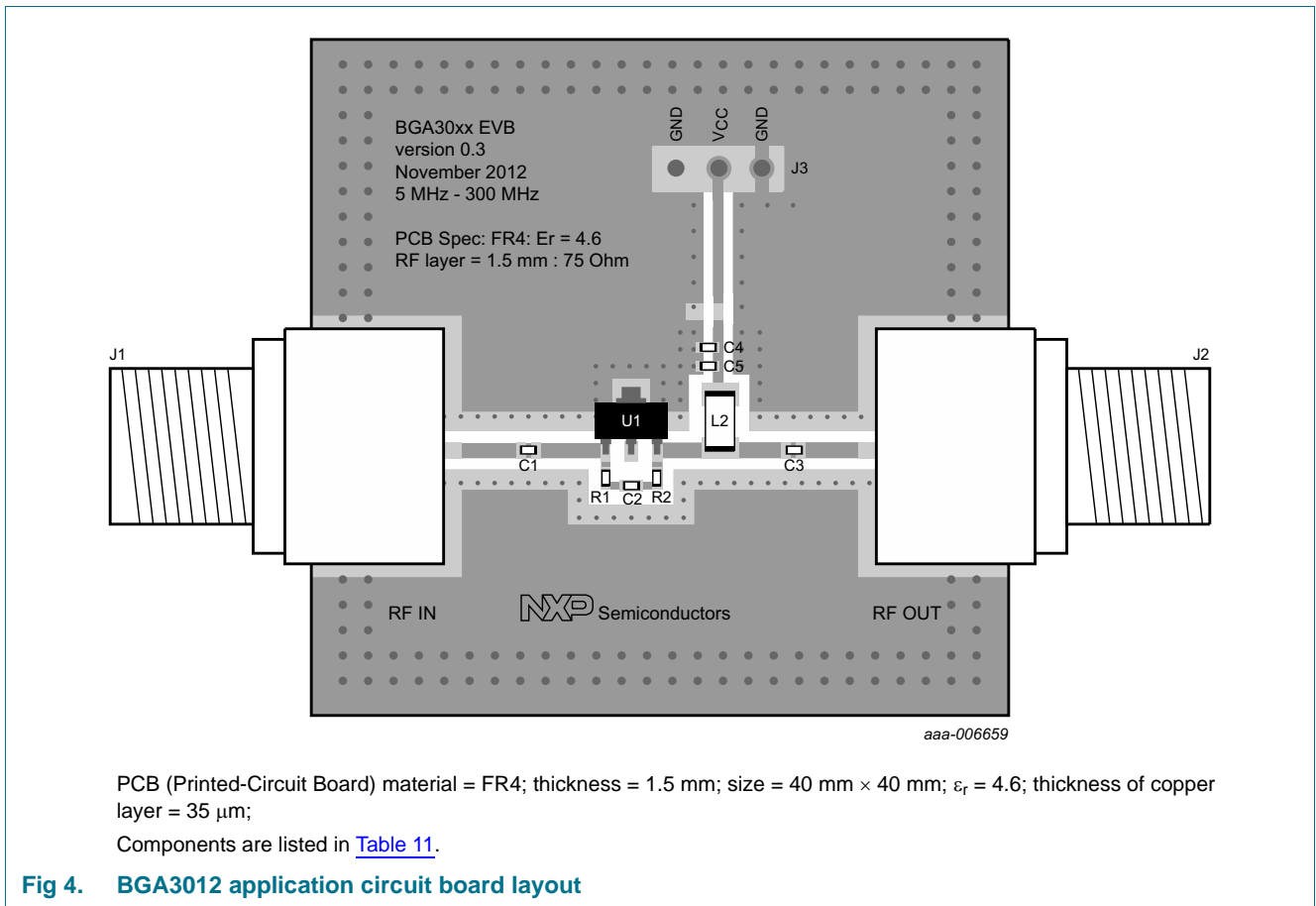

Table 12. List of components

See [Figure 1](#) and [Figure 2](#).

| Component | Description | Value | Size | Remarks |
|----------------|--------------|------------------|----------|--|
| C1, C2, C3, C4 | capacitor | 10 nF | SMD 0402 | Murata GRM155R71E103KA01D or capacitor of same quality |
| C5 | capacitor | 100 pF | SMD 0402 | Murata GRM155C1H101JZ01D or capacitor of same quality |
| J1, J2 | F-connector | 75 Ω | - | Bomar 861V509ER6 or F-connector of same quality |
| J3 | header 3-way | - | - | Molex 90121-0763 or header of the same quality |
| L2 | inductor | 22 μH | SMD 1206 | Murata LQH31CN220K03L or inductor of same quality |
| R1 | resistor | 100 Ω | SMD 0402 | Yageo RC0402FR-07100RL or resistor of same quality |
| R2 | resistor | 300 Ω | SMD 0402 | Yageo RC0402FR-07300RL or resistor of same quality |
| U1 | BGA3012 | - | - | NXP |

9. Package outline

Plastic surface-mounted package; exposed die pad for good heat transfer; 3 leads

SOT89

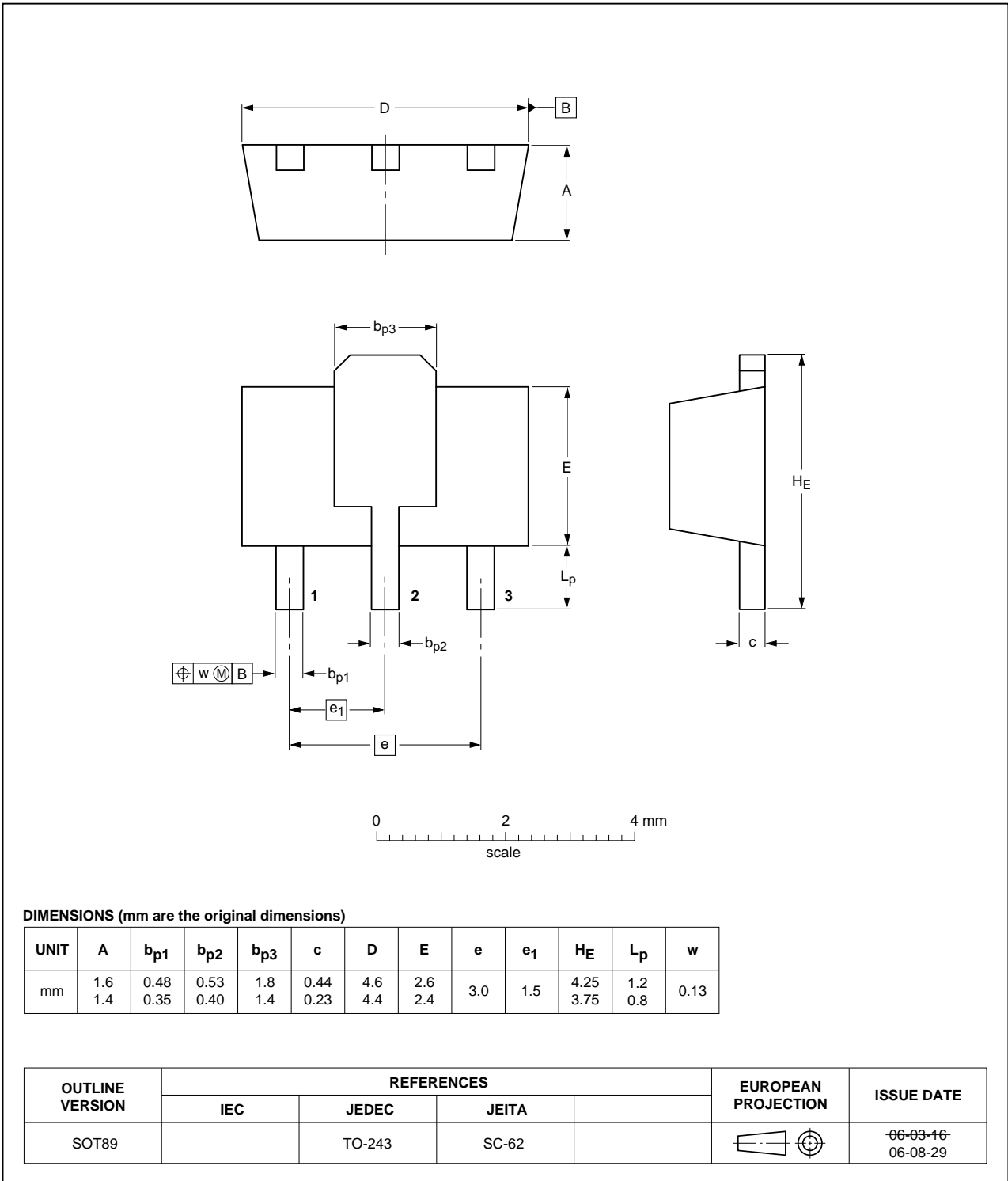

Fig 5. Package outline SOT89 (SC-62)

10. Abbreviations

Table 13. Abbreviations

| Acronym | Description |
|---------|---|
| CATV | Community Antenna TeleVision |
| FTTH | Fiber To The Home |
| FTTx | Fiber To The "x" |
| LNA | Low-Noise Amplifier |
| MMIC | Monolithic Microwave Integrated Circuit |

11. Revision history

Table 14. Revision history

| Document ID | Release date | Data sheet status | Change notice | Supersedes |
|----------------|--|------------------------|---------------|-------------|
| BGA3012 v.3 | 20130926 | Product data sheet | - | BGA3012 v.2 |
| Modifications: | • Table 3 on page 2 : Evaluation boards have been added. | | | |
| BGA3012 v.2 | 20130415 | Product data sheet | - | BGA3012 v.1 |
| BGA3012 v.1 | 20130319 | Preliminary data sheet | - | - |

12. Legal information

12.1 Data sheet status

| Document status ^{[1][2]} | Product status ^[3] | Definition |
|-----------------------------------|-------------------------------|---|
| Objective [short] data sheet | Development | This document contains data from the objective specification for product development. |
| Preliminary [short] data sheet | Qualification | This document contains data from the preliminary specification. |
| Product [short] data sheet | Production | This document contains the product specification. |

[1] Please consult the most recently issued document before initiating or completing a design.

[2] The term 'short data sheet' is explained in section "Definitions".

[3] The product status of device(s) described in this document may have changed since this document was published and may differ in case of multiple devices. The latest product status information is available on the Internet at URL <http://www.nxp.com>.

12.2 Definitions

Draft — The document is a draft version only. The content is still under internal review and subject to formal approval, which may result in modifications or additions. NXP Semiconductors does not give any representations or warranties as to the accuracy or completeness of information included herein and shall have no liability for the consequences of use of such information.

Short data sheet — A short data sheet is an extract from a full data sheet with the same product type number(s) and title. A short data sheet is intended for quick reference only and should not be relied upon to contain detailed and full information. For detailed and full information see the relevant full data sheet, which is available on request via the local NXP Semiconductors sales office. In case of any inconsistency or conflict with the short data sheet, the full data sheet shall prevail.

Product specification — The information and data provided in a Product data sheet shall define the specification of the product as agreed between NXP Semiconductors and its customer, unless NXP Semiconductors and customer have explicitly agreed otherwise in writing. In no event however, shall an agreement be valid in which the NXP Semiconductors product is deemed to offer functions and qualities beyond those described in the Product data sheet.

12.3 Disclaimers

Limited warranty and liability — Information in this document is believed to be accurate and reliable. However, NXP Semiconductors does not give any representations or warranties, expressed or implied, as to the accuracy or completeness of such information and shall have no liability for the consequences of use of such information. NXP Semiconductors takes no responsibility for the content in this document if provided by an information source outside of NXP Semiconductors.

In no event shall NXP Semiconductors be liable for any indirect, incidental, punitive, special or consequential damages (including - without limitation - lost profits, lost savings, business interruption, costs related to the removal or replacement of any products or rework charges) whether or not such damages are based on tort (including negligence), warranty, breach of contract or any other legal theory.

Notwithstanding any damages that customer might incur for any reason whatsoever, NXP Semiconductors' aggregate and cumulative liability towards customer for the products described herein shall be limited in accordance with the *Terms and conditions of commercial sale* of NXP Semiconductors.

Right to make changes — NXP Semiconductors reserves the right to make changes to information published in this document, including without limitation specifications and product descriptions, at any time and without notice. This document supersedes and replaces all information supplied prior to the publication hereof.

Suitability for use — NXP Semiconductors products are not designed, authorized or warranted to be suitable for use in life support, life-critical or safety-critical systems or equipment, nor in applications where failure or malfunction of an NXP Semiconductors product can reasonably be expected to result in personal injury, death or severe property or environmental damage. NXP Semiconductors and its suppliers accept no liability for inclusion and/or use of NXP Semiconductors products in such equipment or applications and therefore such inclusion and/or use is at the customer's own risk.

Applications — Applications that are described herein for any of these products are for illustrative purposes only. NXP Semiconductors makes no representation or warranty that such applications will be suitable for the specified use without further testing or modification.

Customers are responsible for the design and operation of their applications and products using NXP Semiconductors products, and NXP Semiconductors accepts no liability for any assistance with applications or customer product design. It is customer's sole responsibility to determine whether the NXP Semiconductors product is suitable and fit for the customer's applications and products planned, as well as for the planned application and use of customer's third party customer(s). Customers should provide appropriate design and operating safeguards to minimize the risks associated with their applications and products.

NXP Semiconductors does not accept any liability related to any default, damage, costs or problem which is based on any weakness or default in the customer's applications or products, or the application or use by customer's third party customer(s). Customer is responsible for doing all necessary testing for the customer's applications and products using NXP Semiconductors products in order to avoid a default of the applications and the products or of the application or use by customer's third party customer(s). NXP does not accept any liability in this respect.

Limiting values — Stress above one or more limiting values (as defined in the Absolute Maximum Ratings System of IEC 60134) will cause permanent damage to the device. Limiting values are stress ratings only and (proper) operation of the device at these or any other conditions above those given in the Recommended operating conditions section (if present) or the Characteristics sections of this document is not warranted. Constant or repeated exposure to limiting values will permanently and irreversibly affect the quality and reliability of the device.

Terms and conditions of commercial sale — NXP Semiconductors products are sold subject to the general terms and conditions of commercial sale, as published at <http://www.nxp.com/profile/terms>, unless otherwise agreed in a valid written individual agreement. In case an individual agreement is concluded only the terms and conditions of the respective agreement shall apply. NXP Semiconductors hereby expressly objects to applying the customer's general terms and conditions with regard to the purchase of NXP Semiconductors products by customer.

No offer to sell or license — Nothing in this document may be interpreted or construed as an offer to sell products that is open for acceptance or the grant, conveyance or implication of any license under any copyrights, patents or other industrial or intellectual property rights.

Export control — This document as well as the item(s) described herein may be subject to export control regulations. Export might require a prior authorization from competent authorities.

Quick reference data — The Quick reference data is an extract of the product data given in the Limiting values and Characteristics sections of this document, and as such is not complete, exhaustive or legally binding.

Non-automotive qualified products — Unless this data sheet expressly states that this specific NXP Semiconductors product is automotive qualified, the product is not suitable for automotive use. It is neither qualified nor tested in accordance with automotive testing or application requirements. NXP Semiconductors accepts no liability for inclusion and/or use of non-automotive qualified products in automotive equipment or applications.

In the event that customer uses the product for design-in and use in automotive applications to automotive specifications and standards, customer (a) shall use the product without NXP Semiconductors' warranty of the

product for such automotive applications, use and specifications, and (b) whenever customer uses the product for automotive applications beyond NXP Semiconductors' specifications such use shall be solely at customer's own risk, and (c) customer fully indemnifies NXP Semiconductors for any liability, damages or failed product claims resulting from customer design and use of the product for automotive applications beyond NXP Semiconductors' standard warranty and NXP Semiconductors' product specifications.

Translations — A non-English (translated) version of a document is for reference only. The English version shall prevail in case of any discrepancy between the translated and English versions.

12.4 Trademarks

Notice: All referenced brands, product names, service names and trademarks are the property of their respective owners.

13. Contact information

For more information, please visit: <http://www.nxp.com>

For sales office addresses, please send an email to: salesaddresses@nxp.com

14. Contents

| | | |
|-----------|--|-----------|
| 1 | Product profile | 1 |
| 1.1 | General description | 1 |
| 1.2 | Features and benefits | 1 |
| 1.3 | Applications | 1 |
| 1.4 | Quick reference data | 1 |
| 2 | Pinning information | 2 |
| 3 | Ordering information | 2 |
| 4 | Marking | 2 |
| 5 | Limiting values | 2 |
| 6 | Thermal characteristics | 3 |
| 7 | Characteristics | 3 |
| 7.1 | Forward application | 3 |
| 7.2 | Return application | 5 |
| 8 | Application information | 7 |
| 8.1 | Forward application 40 MHz to 1006 MHz | 7 |
| 8.1.1 | Forward application circuit | 7 |
| 8.1.2 | Forward application circuit board layout | 8 |
| 8.2 | Return application 5 MHz to 300 MHz | 9 |
| 8.2.1 | Return application circuit | 9 |
| 8.2.2 | Return application circuit board layout | 10 |
| 9 | Package outline | 11 |
| 10 | Abbreviations | 12 |
| 11 | Revision history | 12 |
| 12 | Legal information | 13 |
| 12.1 | Data sheet status | 13 |
| 12.2 | Definitions | 13 |
| 12.3 | Disclaimers | 13 |
| 12.4 | Trademarks | 14 |
| 13 | Contact information | 14 |
| 14 | Contents | 15 |

Please be aware that important notices concerning this document and the product(s) described herein, have been included in section 'Legal information'.

© NXP B.V. 2013.

All rights reserved.

For more information, please visit: <http://www.nxp.com>

For sales office addresses, please send an email to: salesaddresses@nxp.com

Date of release: 26 September 2013

Document identifier: BGA3012

Looking for pricing, stock, or lifecycle information?

Click below to explore more details on WIN SOURCE:

- [View BGA3012,115 on WIN SOURCE](#)
- [NXP / Nexperia Information](#)

Optimize Your Supply Chain with WIN SOURCE Solutions

- ✓ Global Sourcing Solution
- ✓ Obsolete Management
- ✓ Cost Control Management
- ✓ Shortage Management
- ✓ Alternative Solution
- ✓ Excess Inventory Management