



**THE DATASHEET OF
EQCD-020-15.00-TBL-TED-1-B**



TABLE 4		
END TO END	"L"	
DV TO DV	950	[24.13]
DV TO EM (-TXX)	835	[21.21]
DV TO EM (-SXX)	806	[20.48]
EM (-TXX) TO EM (-TXX)	720	[18.29]
EM (-TXX) TO EM (-SXX)	691	[17.55]
EM (-SXX) TO EM (-SXX)	662	[16.81]
DV-N TO DV-N	840	[21.34]
DV-N TO EM-N (-TXX)	780	[19.81]
DV-N TO EM-N (-SXX)	751	[19.08]

DO NOT SCALE FROM THIS PRINT

FIG. 1
VERTICAL
(EQCD-040-XX.XX-STR-STR-1 SHOWN)
LENGTH: XX.XX + "L" REF (SEE TABLE 4)
(SEE NOTE 14)

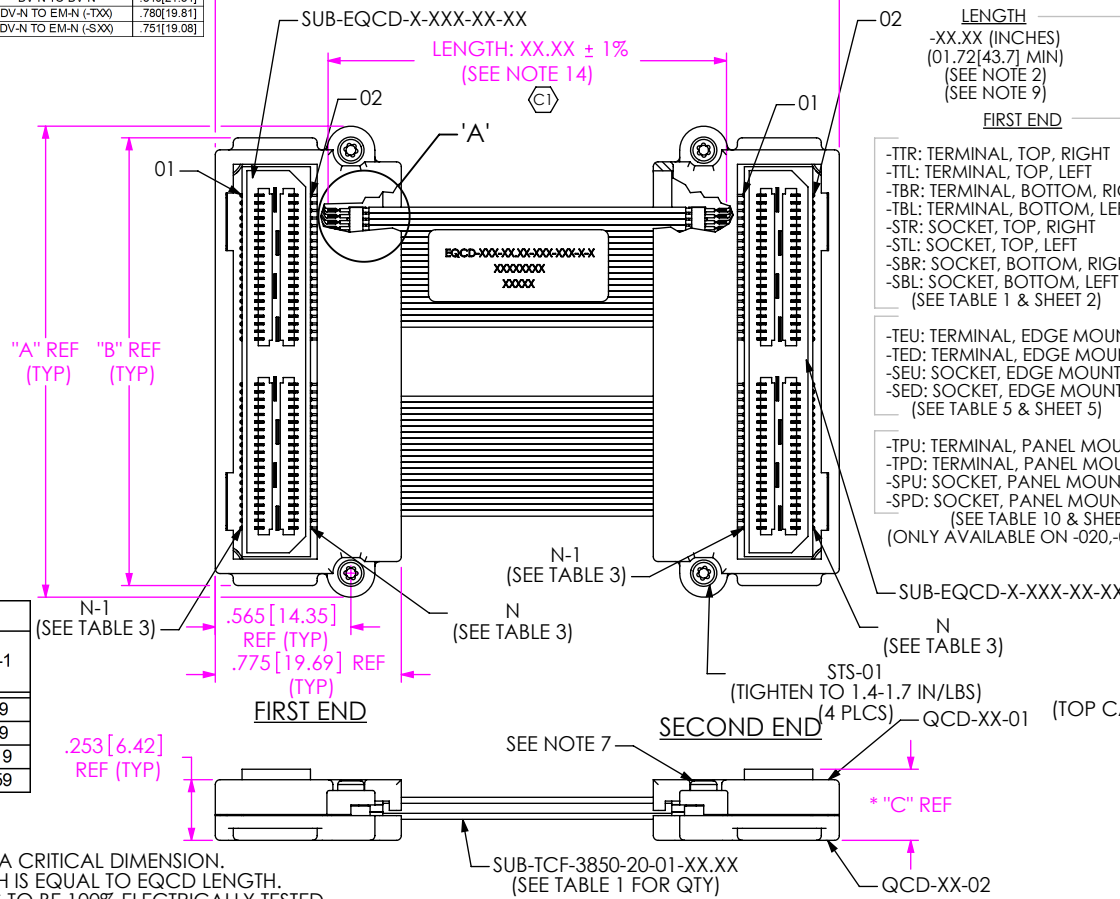

EQCD-XXX-XX.XX-XXX-XXX-X-X

No OF POSITIONS
-020, -040, -060, -080
(PER ROW)

LENGTH
-XX.XX (INCHES)
(01.72[43.7] MIN)
(SEE NOTE 2)
(SEE NOTE 9)

FIRST END

END OPTION

- F: SCREW OPTION FIRST END ONLY (NOT AVAILABLE WITH XPX OPTIONS)
- S: SCREW OPTION SECOND END ONLY
- B: SCREW OPTION BOTH ENDS (NOT AVAILABLE WITH XPX OPTIONS)
- L: FIRST END RT1 OPTION (SEE NOTE 10 & 11)
- R: SECOND END RT1 OPTION (SEE NOTE 10 & 11)
- D: BOTH ENDS RT1 OPTION (SEE NOTE 10 & 11)
- 1: FIRST END SCREW OPTION, SECOND END RT1 OPTION (SEE NOTE 10 & 11)
- 2: FIRST END RT1 OPTION, SECOND END SCREW OPTION (SEE NOTE 10 & 11)
- N: NO CAPS (LEAVE BLANK FOR STANDARD CAPS BOTH ENDS) (SEE FIG. 3, SHEET 5 FOR EDGE MOUNT END OPTIONS) (SEE FIG. 4, SHEET 5 FOR DOUBLE VERTICAL END OPTIONS) (RT1 OPTIONS NOT AVAILABLE WITH XPX OR XEX OPTIONS) (RT1 OPTIONS NOT AVAILABLE FOR 080 POSITION) (SEE SHEET 6 FOR RT1 AND NO CAP OPTIONS)

WIRING OPTION

SECOND END

- 1: PIN 1 TO PIN 1
- 2: PIN 1 TO PIN 2
- 3: PIN 1 TO PIN N-1
- 4: PIN 1 TO PIN N (SEE TABLE 9, SHEET 7)

- TTR: TERMINAL, TOP, RIGHT
- TTL: TERMINAL, TOP, LEFT
- TBR: TERMINAL, BOTTOM, RIGHT
- TBL: TERMINAL, BOTTOM, LEFT
- STR: SOCKET, TOP, RIGHT
- STL: SOCKET, TOP, LEFT
- SBR: SOCKET, BOTTOM, RIGHT
- SBL: SOCKET, BOTTOM, LEFT (SEE TABLE 1 & SHEET 2)
- TEU: TERMINAL, EDGE MOUNT, UP
- TED: TERMINAL, EDGE MOUNT, DOWN
- SEU: SOCKET, EDGE MOUNT, UP
- SED: SOCKET, EDGE MOUNT, DOWN (SEE TABLE 5 & SHEET 5)
- TPU: TERMINAL, PANEL MOUNT, UP
- TPD: TERMINAL, PANEL MOUNT, DOWN
- SPU: SOCKET, PANEL MOUNT, UP
- SPD: SOCKET, PANEL MOUNT, DOWN (SEE TABLE 10 & SHEET 5) (ONLY AVAILABLE ON -020, -040, AND -060)
- TEU: TERMINAL, EDGE MOUNT, UP
- TED: TERMINAL, EDGE MOUNT, DOWN
- SEU: SOCKET, EDGE MOUNT, UP
- SED: SOCKET, EDGE MOUNT, DOWN (SEE TABLE 5 & SHEET 5)

TABLE 3

No. OF POSITIONS	N	N-1
-020	40	39
-040	80	79
-060	120	119
-080	160	159

- NOTES:**
- ⊙ REPRESENTS A CRITICAL DIMENSION.
 - SUB-TCF LENGTH IS EQUAL TO EQCD LENGTH.
 - ⊙3. ALL ASSEMBLIES TO BE 100% ELECTRICALLY TESTED FOR SHORTS AND OPENS.
 - ⊙3. ALL ASSEMBLIES TO BE 100% HI-POT TESTED AT 300V.
 - TOP SUB-TCF NOT SHOWN IN THIS VIEW FOR CLARITY; HDRL-11 TO BE CENTERED ON LOWER SUB-TCF AS SHOWN; HDRL-11 IS TO CONTAIN PART NUMBER, SHOP ORDER & DATE CODE.
 - PACKAGE ASSEMBLIES IN ANTI-STATIC & STATIC DISSIPATIVE BAGS.
 - TOP SURFACE OF SCREW TO BE FLUSH OR BELOW TOP SURFACE OF CAP.
 - PARTS TO BE PROCESSED PER SAMTEC ACCEPTABILITY REQUIREMENTS: HDR-PI-01 "CABLE ASSEMBLY WORKMANSHIP STANDARDS".
 - CABLE LENGTHS LONGER THAN 40.00 INCHES ARE NOT SUPPORTED BY S.I. TEST DATA.
 - RT1 OPTION IS NOT AVAILABLE WITH EDGMOUNT OR PANEL MOUNT END OPTIONS.
 - RT1 OPTION IS NOT AVAILABLE WITH -080 POSITIONS.
 - ALL POSITIONS ARE TRANSMITTED AS SIGNALS ACROSS COAX CENTER CONDUCTORS. CONNECTOR GROUND BLADES ARE TIED TO THE COAX SHIELD. FOR MULTIPLE BANK ASSEMBLIES, EACH BANK IS GROUND INDEPENDENT OF THE OTHERS.
 - REFER TO PREP-SPEC DRAWING FOR CABLE PREP DIMENSIONS. ASSEMBLY USES STANDARD PCB PREP.
 - FOR CABLE LENGTHS LESS THAN 5 INCHES, CABLE LENGTH AND OVERALL LENGTH TOLERANCE IS ±0.05 INCHES. FOR CABLE LENGTHS GREATER THAN 5 INCHES, USE ±1% FOR BOTH.

THIS PRODUCT MANUFACTURED WITH LEAD-FREE PROCESSING

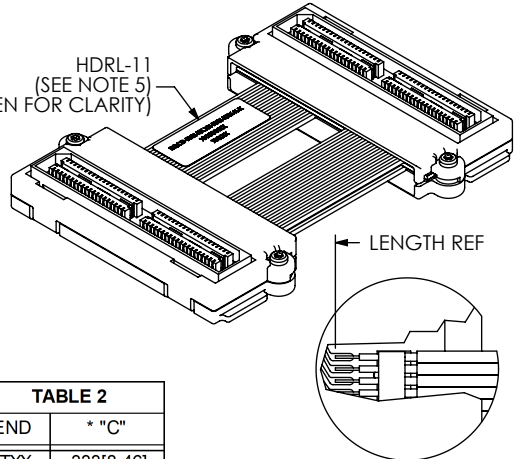

TABLE 2

END	* "C"
-TXX	.333[8.46]
-SXX	.296[7.52]

* -DV END OPTIONS ONLY

DETAIL 'A'
SCALE 2.5 : 1

TABLE 1

No. OF POSITIONS	"A"	"B"	QCD-XX-01	QCD-XX-02	QTY OF SUB-TCF	SUB-EQCD-X-XXX-XX-XX
-020	1.175[29.85]	1.078[27.38]	QCD-01-01	QCD-01-02	2	SUB-EQCD-X-020-XX-XX
-040	1.963[49.85]	1.866[47.40]	QCD-02-01	QCD-02-02	4	SUB-EQCD-X-040-XX-XX
-060	2.750[69.85]	2.653[67.39]	QCD-03-01	QCD-03-02	6	SUB-EQCD-X-060-XX-XX
-080	3.538[89.85]	3.441[87.39]	QCD-04-01	QCD-04-02	8	SUB-EQCD-X-080-XX-XX

UNLESS OTHERWISE SPECIFIED, DIMENSIONS ARE IN INCHES. TOLERANCES ARE:

DECIMALS ANGLES
.XX: ±.01 [.3] 2°
.XXX: ±.005 [.13]
.XXXX: ±.0020 [.051]

MATERIAL: DO NOT SCALE DRAWING SHEET SCALE: 1:0.8

PLATING:
-H GOLD: 30µ" CONTACT

F:\DWG\MISC\MKTG\EQCD-XXX-XX.XX-XXX-XXX-X-X-MKT.SLDDRW

PROPRIETARY NOTE
THIS DOCUMENT CONTAINS CONFIDENTIAL AND PROPRIETARY INFORMATION AND ALL DESIGN, MANUFACTURING, REPRODUCTION, USE, PATENT RIGHTS AND SALES RIGHTS ARE EXPRESSLY RESERVED BY SAMTEC, INC. THIS DOCUMENT SHALL NOT BE DISCLOSED, IN WHOLE OR PART, TO ANY UNAUTHORIZED PERSON OR ENTITY NOR REPRODUCED, TRANSFERRED OR INCORPORATED IN ANY OTHER PROJECT IN ANY MANNER WITHOUT THE EXPRESS WRITTEN CONSENT OF SAMTEC, INC.

samtec

520 PARK EAST BLVD, NEW ALBANY, IN 47150
PHONE: 812-944-6733 FAX: 812-948-5047
e-Mail: info@SAMTEC.com code: 55322

DESCRIPTION:
0.8mm HIGH-SPEED COAX CABLE ASSEMBLY

DWG. NO.
EQCD-XXX-XX.XX-XXX-XXX-X-X

BY: KEVIN B 02/19/03 SHEET 1 OF 7

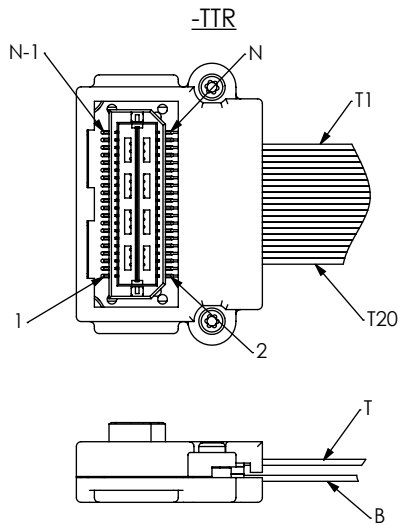

WIRING OPTION	FIRST END PIN #	SECOND END PIN #	WIRE NUMBER
1	1	1	B20
2	1	2	B20
3	1	N-1	B20
4	1	N	B20

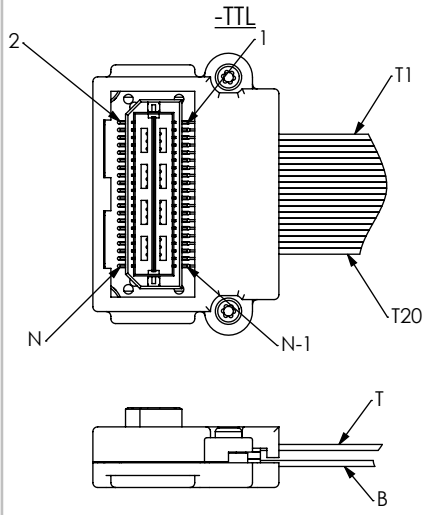

WIRING OPTION	FIRST END PIN #	SECOND END PIN #	WIRE NUMBER
1	1	1	T1
2	1	2	T1
3	1	N-1	T1
4	1	N	T1

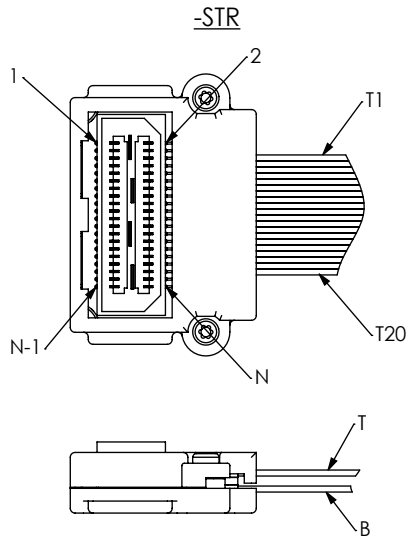

WIRING OPTION	FIRST END PIN #	SECOND END PIN #	WIRE NUMBER
1	1	1	B1
2	1	2	B1
3	1	N-1	B1
4	1	N	B1

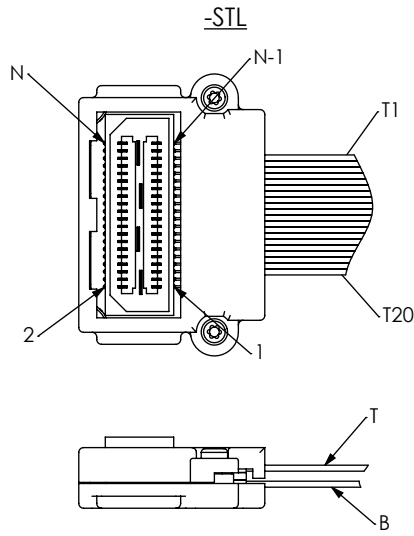

WIRING OPTION	FIRST END PIN #	SECOND END PIN #	WIRE NUMBER
1	1	1	T20
2	1	2	T20
3	1	N-1	T20
4	1	N	T20

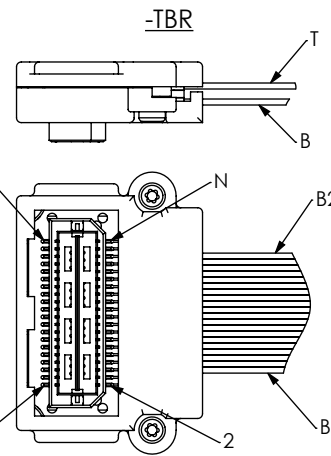

WIRING OPTION	FIRST END PIN #	SECOND END PIN #	WIRE NUMBER
1	1	1	T1
2	1	2	T1
3	1	N-1	T1
4	1	N	T1

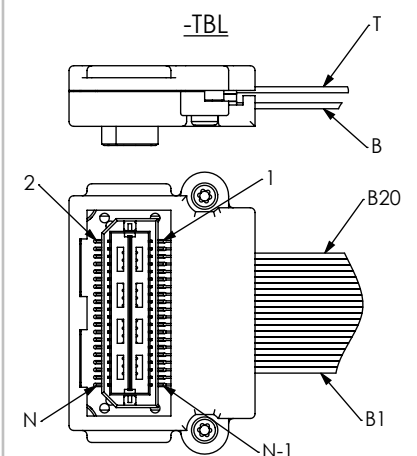

WIRING OPTION	FIRST END PIN #	SECOND END PIN #	WIRE NUMBER
1	1	1	B20
2	1	2	B20
3	1	N-1	B20
4	1	N	B20

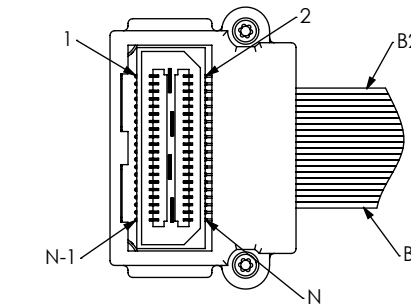
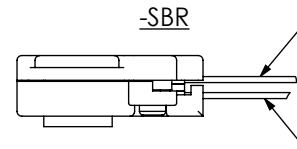

WIRING OPTION	FIRST END PIN #	SECOND END PIN #	WIRE NUMBER
1	1	1	T20
2	1	2	T20
3	1	N-1	T20
4	1	N	T20

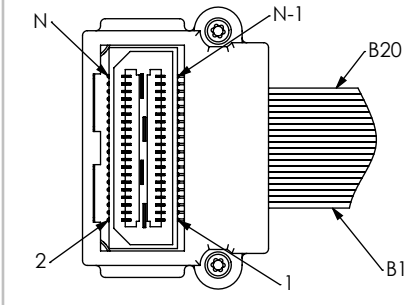
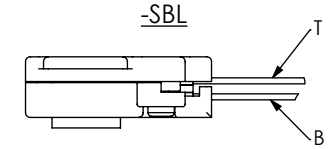

WIRING OPTION	FIRST END PIN #	SECOND END PIN #	WIRE NUMBER
1	1	1	B1
2	1	2	B1
3	1	N-1	B1
4	1	N	B1

PROPRIETARY NOTE
 THIS DOCUMENT CONTAINS CONFIDENTIAL AND PROPRIETARY INFORMATION AND ALL DESIGN, MANUFACTURING, REPRODUCTION, USE, PATENT RIGHTS AND SALES RIGHTS ARE EXPRESSLY RESERVED BY SAMTEC, INC. THIS DOCUMENT SHALL NOT BE DISCLOSED, IN WHOLE OR PART, TO ANY UNAUTHORIZED PERSON OR ENTITY NOR REPRODUCED, TRANSFERRED OR INCORPORATED IN ANY OTHER PROJECT IN ANY MANNER WITHOUT THE EXPRESS WRITTEN CONSENT OF SAMTEC, INC.

DO NOT SCALE DRAWING

SHEET SCALE: 1:25:1



520 PARK EAST BLVD, NEW ALBANY, IN 47150
 PHONE: 812-944-6733 FAX: 812-948-5047
 e-Mail: info@SAMTEC.com code: 53322

DESCRIPTION:
 0.8mm HIGH-SPEED COAX CABLE ASSEMBLY

DWG. NO.
 EQCD-XXX-XX.XX-XXX-XXX-X-X

BY: KEVIN B 02/19/03 SHEET 2 OF 7

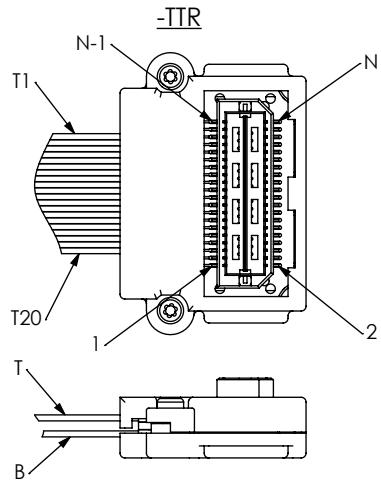

WIRING OPTION	FIRST END PIN #	SECOND END PIN #
1	1	1
2	1	2
3	1	N-1
4	1	N

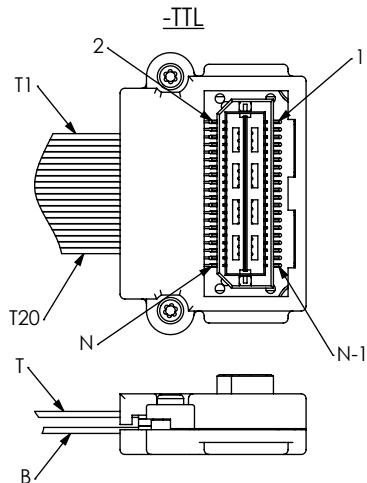

WIRING OPTION	FIRST END PIN #	SECOND END PIN #
1	1	1
2	1	2
3	1	N-1
4	1	N

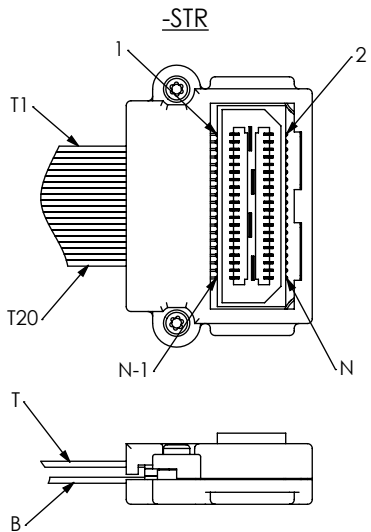

WIRING OPTION	FIRST END PIN #	SECOND END PIN #
1	1	1
2	1	2
3	1	N-1
4	1	N

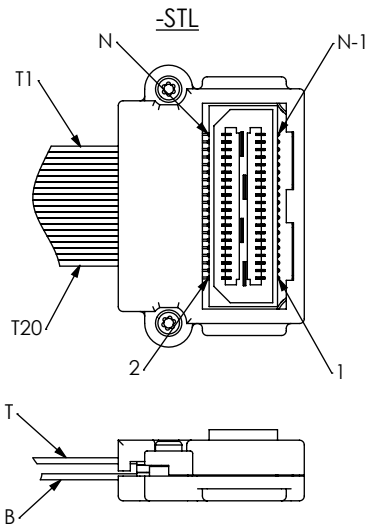

WIRING OPTION	FIRST END PIN #	SECOND END PIN #
1	1	1
2	1	2
3	1	N-1
4	1	N

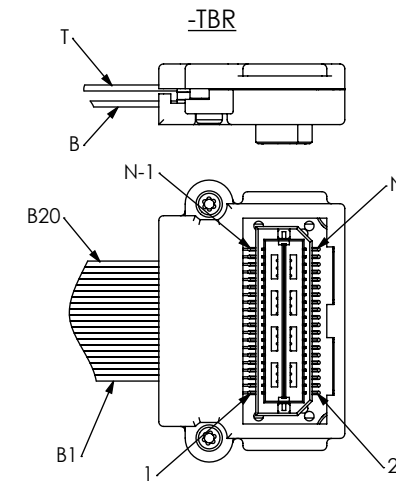

WIRING OPTION	FIRST END PIN #	SECOND END PIN #
1	1	1
2	1	2
3	1	N-1
4	1	N

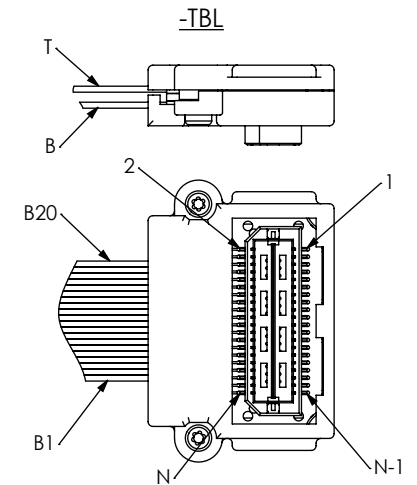

WIRING OPTION	FIRST END PIN #	SECOND END PIN #
1	1	1
2	1	2
3	1	N-1
4	1	N

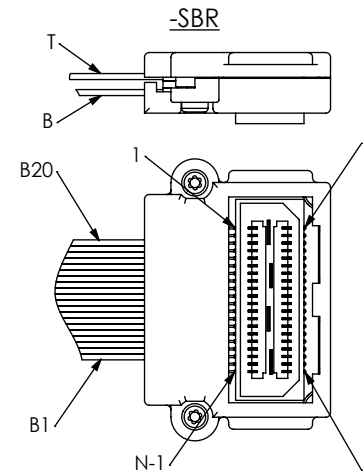

WIRING OPTION	FIRST END PIN #	SECOND END PIN #
1	1	1
2	1	2
3	1	N-1
4	1	N

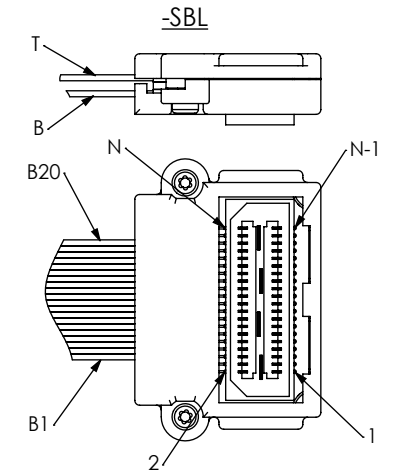

WIRING OPTION	FIRST END PIN #	SECOND END PIN #
1	1	1
2	1	2
3	1	N-1
4	1	N

PROPRIETARY NOTE
 THIS DOCUMENT CONTAINS CONFIDENTIAL AND PROPRIETARY INFORMATION AND ALL DESIGN, MANUFACTURING, REPRODUCTION, USE, PATENT RIGHTS AND SALES RIGHTS ARE EXPRESSLY RESERVED BY SAMTEC, INC. THIS DOCUMENT SHALL NOT BE DISCLOSED, IN WHOLE OR PART, TO ANY UNAUTHORIZED PERSON OR ENTITY NOR REPRODUCED, TRANSFERRED OR INCORPORATED IN ANY OTHER PROJECT IN ANY MANNER WITHOUT THE EXPRESS WRITTEN CONSENT OF SAMTEC, INC.

DO NOT SCALE DRAWING

SHEET SCALE: 1:25:1



520 PARK EAST BLVD, NEW ALBANY, IN 47150
 PHONE: 812-944-6733 FAX: 812-948-5047
 e-Mail: info@SAMTEC.com code: 53322

DESCRIPTION:
 0.8mm HIGH-SPEED COAX CABLE ASSEMBLY

DWG. NO.
 EQCD-XXX-XX.XX-XXX-XXX-X-X

BY: KEVIN B 02/19/03 SHEET 3 OF 7

REVISION AB

FIRST END - EDGE MOUNT (SEE TABLE 9, SHEET 7)

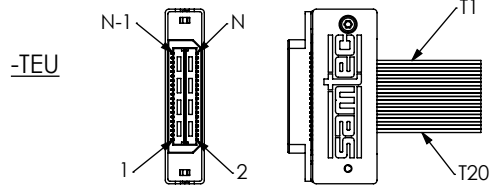

WIRING OPTION	FIRST END PIN #	SECOND END PIN #	WIRE #
1	1	1	T1
2	1	2	T1
3	1	N-1	T1
4	1	N	T1

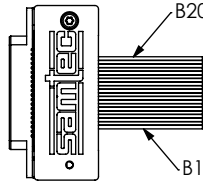
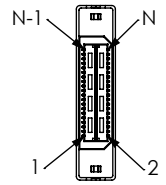
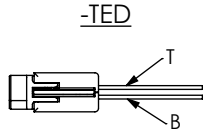

WIRING OPTION	FIRST END PIN #	SECOND END PIN #	WIRE #
1	1	1	B20
2	1	2	B20
3	1	N-1	B20
4	1	N	B20

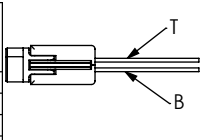

SECOND END - EDGE MOUNT (SEE TABLE 9, SHEET 7)

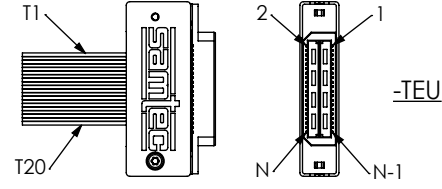

WIRING OPTION	FIRST END PIN #	SECOND END PIN #
1	1	1
2	1	2
3	1	N-1
4	1	N

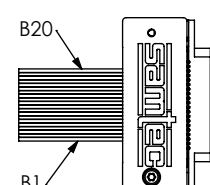
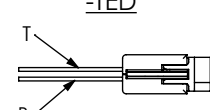

WIRING OPTION	FIRST END PIN #	SECOND END PIN #
1	1	1
2	1	2
3	1	N-1
4	1	N

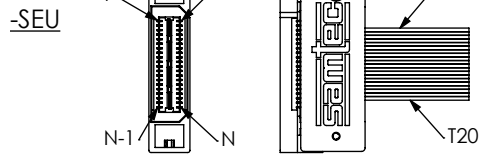
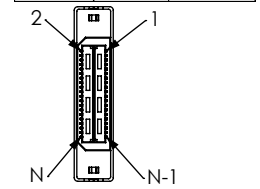

WIRING OPTION	FIRST END PIN #	SECOND END PIN #	WIRE #
1	1	1	T20
2	1	2	T20
3	1	N-1	T20
4	1	N	T20

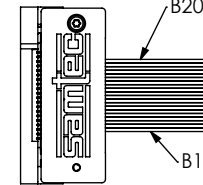
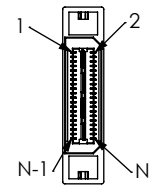
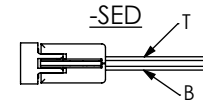

WIRING OPTION	FIRST END PIN #	SECOND END PIN #	WIRE #
1	1	1	B1
2	1	2	B1
3	1	N-1	B1
4	1	N	B1

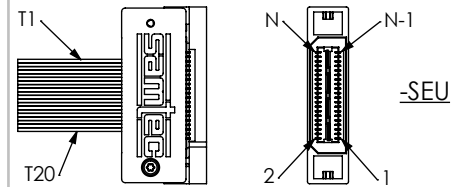
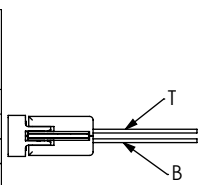

WIRING OPTION	FIRST END PIN #	SECOND END PIN #
1	1	1
2	1	2
3	1	N-1
4	1	N

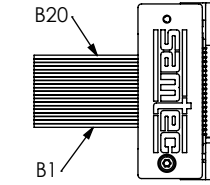
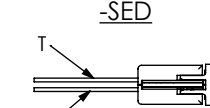

WIRING OPTION	FIRST END PIN #	SECOND END PIN #
1	1	1
2	1	2
3	1	N-1
4	1	N

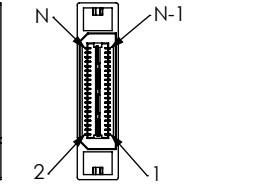

FIRST END - PANEL MOUNT (SEE TABLE 9, SHEET 6)

-SPU

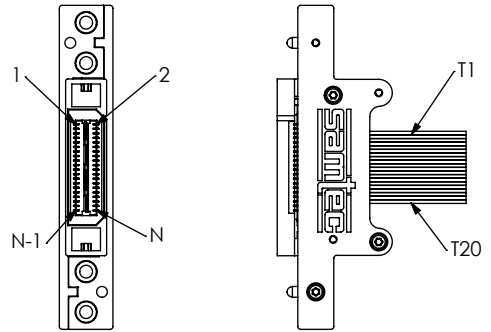

WIRING OPTION	FIRST END PIN #	SECOND END PIN #	WIRE #
1	1	1	B1
2	1	2	B1
3	1	N-1	B1
4	1	N	B1

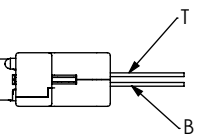

-SPD

WIRING OPTION	FIRST END PIN #	SECOND END PIN #	WIRE #
1	1	1	T20
2	1	2	T20
3	1	N-1	T20
4	1	N	T20

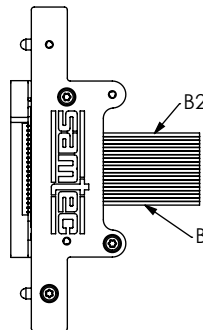
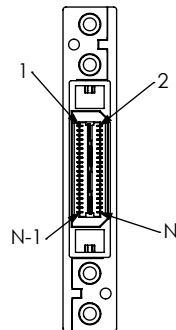
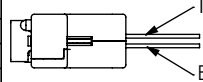

-TPU

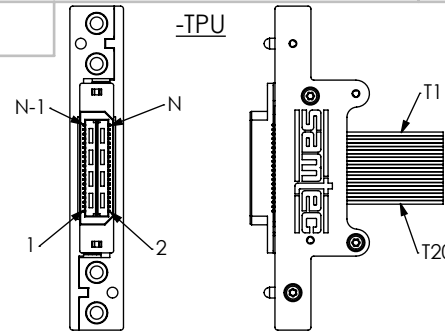

WIRING OPTION	FIRST END PIN #	SECOND END PIN #	WIRE #
1	1	1	B20
2	1	2	B20
3	1	N-1	B20
4	1	N	B20

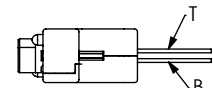

WIRING OPTION	FIRST END PIN #	SECOND END PIN #	WIRE #
1	1	1	T1
2	1	2	T1
3	1	N-1	T1
4	1	N	T1

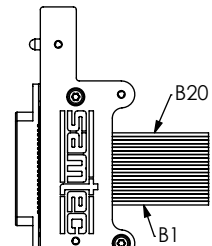
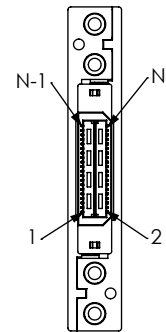

PROPRIETARY NOTE
 THIS DOCUMENT CONTAINS CONFIDENTIAL AND PROPRIETARY INFORMATION AND ALL DESIGN, MANUFACTURING, REPRODUCTION, USE, PATENT RIGHTS AND SALES RIGHTS ARE EXPRESSLY RESERVED BY SAMTEC, INC. THIS DOCUMENT SHALL NOT BE DISCLOSED, IN WHOLE OR PART, TO ANY UNAUTHORIZED PERSON OR ENTITY NOR REPRODUCED, TRANSFERRED OR INCORPORATED IN ANY OTHER PROJECT IN ANY MANNER WITHOUT THE EXPRESS WRITTEN CONSENT OF SAMTEC, INC.

DO NOT SCALE DRAWING
 SHEET SCALE: 1:1



520 PARK EAST BLVD, NEW ALBANY, IN 47150
 PHONE: 812-944-6733 FAX: 812-948-5047
 e-Mail: info@SAMTEC.com code: 53322

DESCRIPTION:
 0.8mm HIGH-SPEED COAX CABLE ASSEMBLY
 DWG. NO.
 EQCD-XXX-XX.XX-XXX-XXX-X-X
 BY: KEVIN B 02/19/03 SHEET 4 OF 7

FIG 3
EDGE MOUNT (WITH CAPTIVE PANEL SCREWS)
(EQCD-020-XX.XX-SEU-XXX-1-F SHOWN)
(SAME AS FIG. 2, UNLESS OTHERWISE STATED)

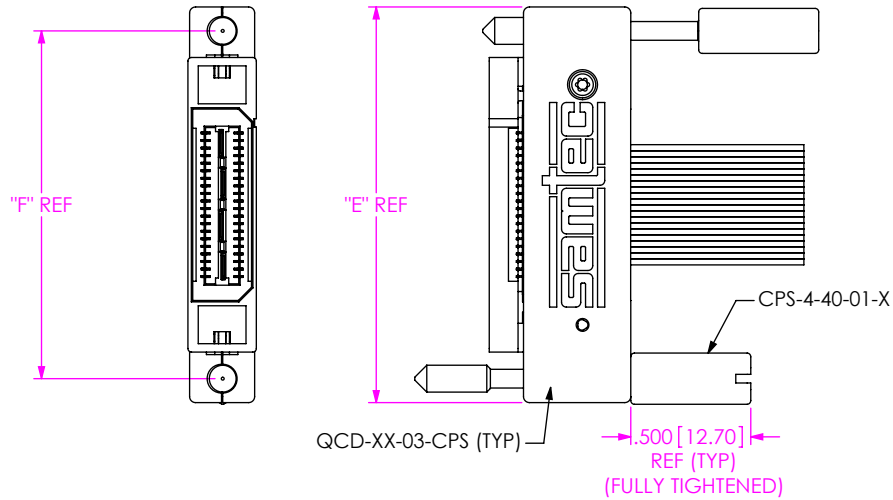

No. OF POSITIONS	"E"	"F"	QCD-XX-03-CPS
-020	1.649[41.87]	1.449[36.80]	QCD-01-03-CPS
-040	2.436[61.87]	2.237[56.80]	QCD-02-03-CPS
-060	3.224[81.87]	3.024[76.80]	QCD-03-03-CPS
-080	4.011[101.87]	3.812[96.80]	QCD-04-03-CPS

FIG 2
EDGE MOUNT (NO CAPTIVE PANEL SCREWS)
(EQCD-020-XX.XX-TEU-STR-X SHOWN)
(SAME AS FIG. 1, UNLESS OTHERWISE STATED)

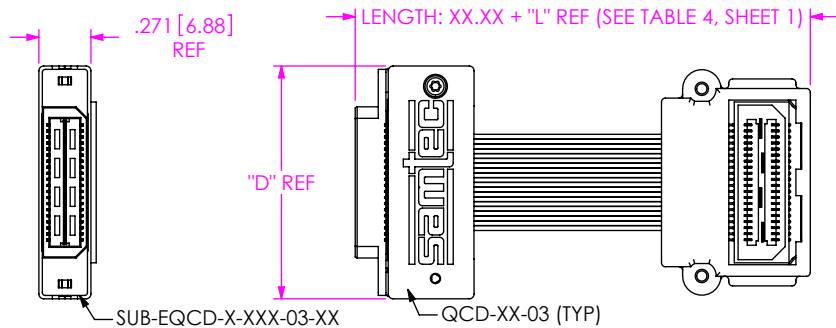

No. OF POSITIONS	"D"	QCD-XXX-03	SUB-EQCD-X-XXX-XX-XX
-020	1.213[30.80]	QCD-01-03	SUB-EQCD-X-020-03-XX
-040	2.000[50.80]	QCD-02-03	SUB-EQCD-X-040-03-XX
-060	2.788[70.80]	QCD-03-03	SUB-EQCD-X-060-03-XX
-080	3.575[90.80]	QCD-04-03	SUB-EQCD-X-080-03-XX

FIG 4
DOUBLE VERTICAL (WITH SCREW DOWN OPTION)
(EQCD-020-XX.XX-TTR-XXX-1-F SHOWN)
(SAME AS FIG. 1, UNLESS OTHERWISE STATED)

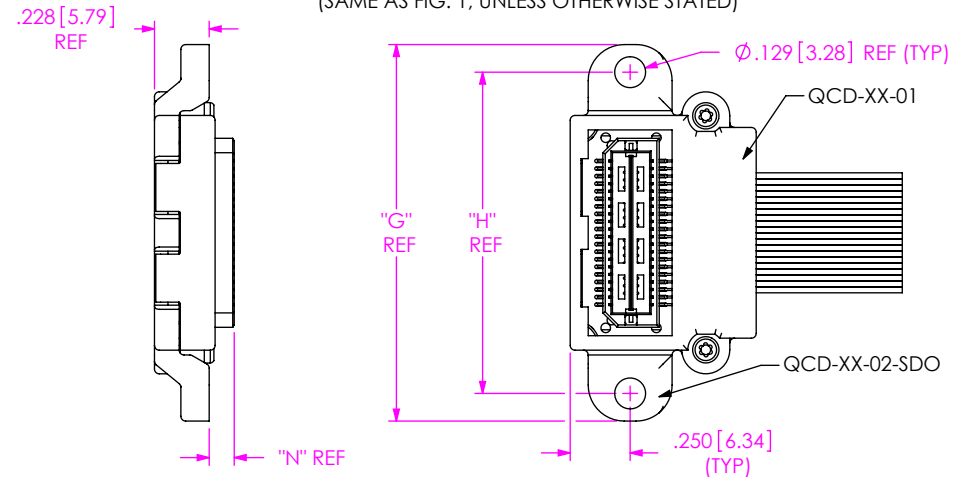

END	"N"
-TXX	.104[2.65]
-SXX	.068[1.73]

No. OF POSITIONS	"G"	"H"	QCD-XX-02-SDO
-020	1.579[40.10]	1.339[34.00]	QCD-01-02-SDO
-040	2.366[60.10]	2.126[54.00]	QCD-02-02-SDO
-060	3.154[80.10]	2.913[74.00]	QCD-03-02-SDO
-080	3.941[100.10]	3.701[94.00]	QCD-04-02-SDO

FIG 5
PANEL MOUNT (BULK HEAD SCREW INSERTS)
(EQCD-020-XX.XX-TPU-XXX-X SHOWN)
(SAME AS FIG. 2, UNLESS OTHERWISE STATED)

No. OF POSITIONS	"J"	"K"	"L"	"M"	SUB-QCD-XX-03-BULK
-020	2.010 [51.05]	1.449 [36.80]	2.250 [57.15]	1.73 [43.94]	SUB-QCD-01-03-BULK
-040	2.798 [71.07]	2.237 [56.82]	3.038 [77.17]	2.518 [63.96]	SUB-QCD-02-03-BULK
-060	3.586 [91.08]	3.024 [76.81]	3.826 [97.18]	3.306 [83.97]	SUB-QCD-03-03-BULK

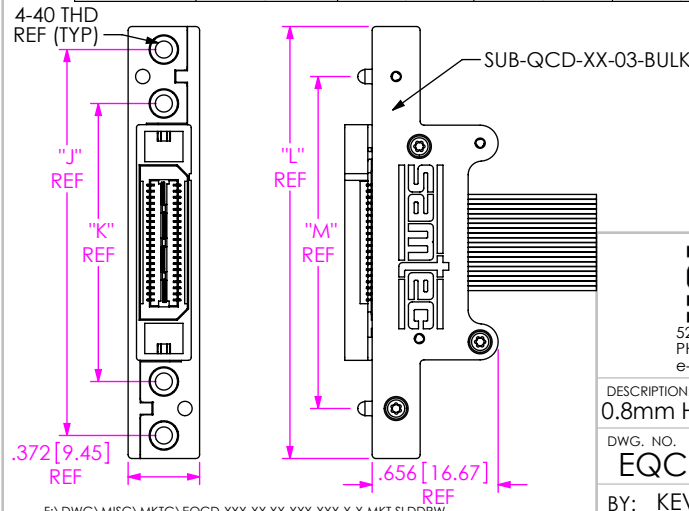

PROPRIETARY NOTE
THIS DOCUMENT CONTAINS CONFIDENTIAL AND PROPRIETARY INFORMATION AND ALL DESIGN, MANUFACTURING, REPRODUCTION, USE, PATENT RIGHTS AND SALES RIGHTS ARE EXPRESSLY RESERVED BY SAMTEC, INC. THIS DOCUMENT SHALL NOT BE DISCLOSED, IN WHOLE OR PART, TO ANY UNAUTHORIZED PERSON OR ENTITY NOR REPRODUCED, TRANSFERRED OR INCORPORATED IN ANY OTHER PROJECT IN ANY MANNER WITHOUT THE EXPRESS WRITTEN CONSENT OF SAMTEC, INC.

SHEET SCALE: 1.25:1



520 PARK EAST BLVD, NEW ALBANY, IN 47150
PHONE: 812-944-6733 FAX: 812-948-5047
e-Mail: info@SAMTEC.com code: 55322

DESCRIPTION:
0.8mm HIGH-SPEED COAX CABLE ASSEMBLY

DWG. NO.
EQCD-XXX-XX.XX-XXX-XXX-X-X

BY: KEVIN B 02/19/03 SHEET 5 OF 7

FIG 6
(EQCD-020-XX.X-STL-TTR-1-D SHOWN)
(SAME AS FIG 1, UNLESS OTHERWISE STATED)

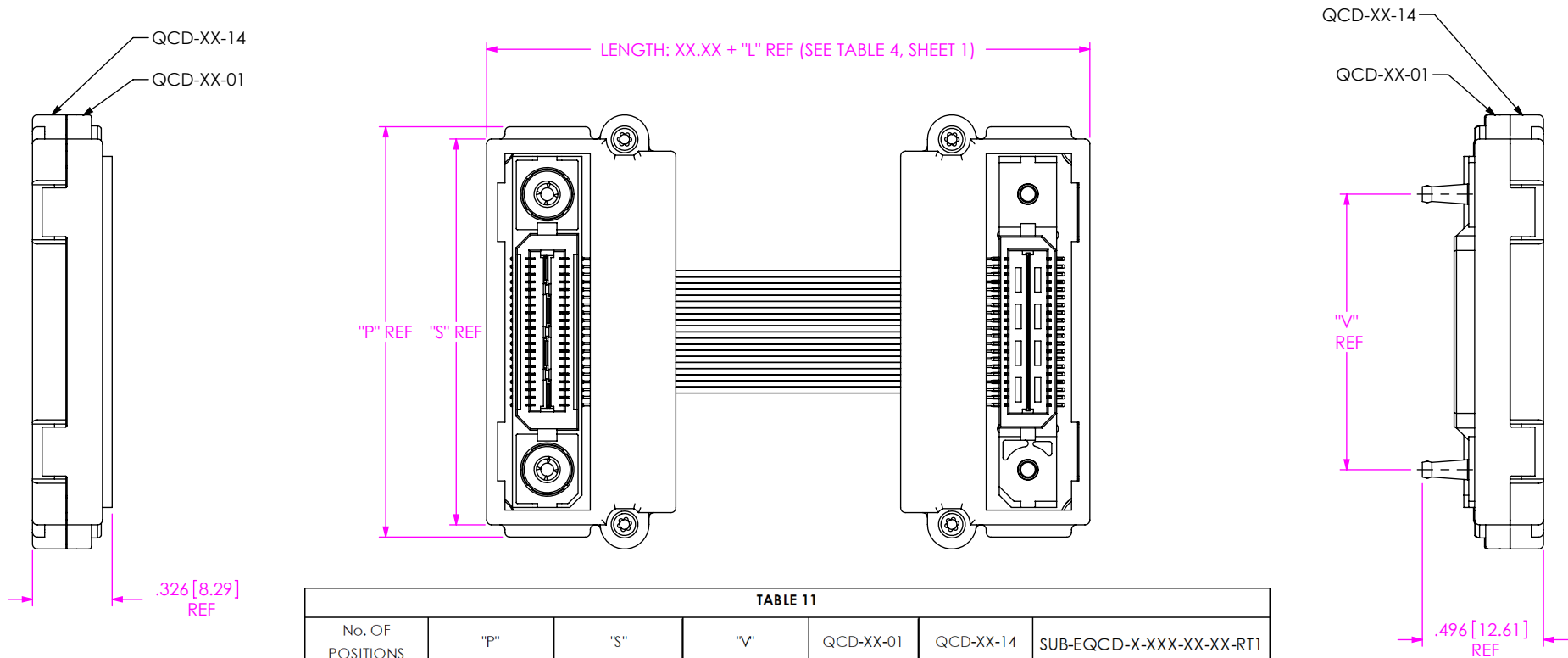

TABLE 11

No. OF POSITIONS	"P"		"S"		"V"		QCD-XX-01	QCD-XX-14	SUB-EQCD-X-XXX-XX-XX-RT1
-020	1.777	[45.14]	1.680	[42.67]	1.129	[28.66]	QCD-07-01	QCD-01-14	SUB-EQCD-X-020-XX-XX-RT1
-040	2.565	[65.15]	2.468	[62.69]	1.916	[48.67]	QCD-08-01	QCD-02-14	SUB-EQCD-X-040-XX-XX-RT1
-060	3.352	[85.14]	3.255	[82.68]	2.704	[68.67]	QCD-09-01	QCD-03-14	SUB-EQCD-X-060-XX-XX-RT1
-080	4.140	[105.16]	4.043	[102.69]	3.491	[88.67]	QCD-10-01	QCD-04-14	SUB-EQCD-X-080-XX-XX-RT1

FIG 7
(EQCD-XXX-XX.X-XXX-XXX-X-N)
(SAME AS FIG 1, UNLESS OTHERWISE STATED)

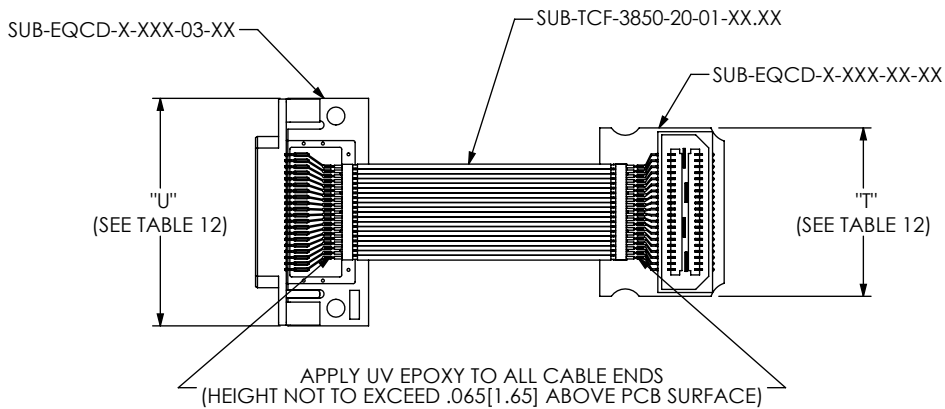

TABLE 12

No. OF POSITIONS	"T"	"U"
-20	0.877 [22.28]	1.185 [30.10]
-40	1.665 [42.29]	1.973 [50.11]
-60	2.453 [62.31]	2.760 [70.10]
-80	3.240 [82.30]	3.548 [90.12]

PROPRIETARY NOTE

THIS DOCUMENT CONTAINS CONFIDENTIAL AND PROPRIETARY INFORMATION AND ALL DESIGN, MANUFACTURING, REPRODUCTION, USE, PATENT RIGHTS AND SALES RIGHTS ARE EXPRESSLY RESERVED BY SAMTEC, INC. THIS DOCUMENT SHALL NOT BE DISCLOSED, IN WHOLE OR PART, TO ANY UNAUTHORIZED PERSON OR ENTITY NOR REPRODUCED, TRANSFERRED OR INCORPORATED IN ANY OTHER PROJECT IN ANY MANNER WITHOUT THE EXPRESS WRITTEN CONSENT OF SAMTEC, INC.

SHEET SCALE: 1.5:1



520 PARK EAST BLVD, NEW ALBANY, IN 47150
PHONE: 812-944-6733 FAX: 812-948-5047
e-Mail: info@SAMTEC.com code: 55322

DESCRIPTION:
0.8mm HIGH-SPEED COAX CABLE ASSEMBLY

DWG. NO.
EQCD-XXX-XX.XX-XXX-XXX-X-X

BY: KEVIN B 02/19/03 SHEET 6 OF 7

		TABLE 9																		
FIRST END OPTION	FIRST END SUB-EQCD-X-XXX-XX-01	WIRING OPTION	FIRST END PIN #	SECOND END PIN #	WIRE #	SECOND END OPTION (SUB-EQCD-X-XXX-XX-XX)														
						-TTR	-TTL	-TBR	-TBL	-STR	-STL	-SBR	-SBL	-TEU	-TED	-SEU	-SED			
-TTR	-T-XXX-01-01	1	1	1	B20	-T-XXX-02-02	N/A	N/A	-T-XXX-01-02	N/A	-S-XXX-01-01	-S-XXX-02-01	N/A	N/A	-T-XXX-03-02	-S-XXX-03-01	N/A			
		2	1	2	B20	-T-XXX-02-01	N/A	N/A	-T-XXX-01-01	N/A	-S-XXX-01-02	-S-XXX-02-02	N/A	N/A	-T-XXX-03-01	-S-XXX-03-02	N/A			
		3	1	N-1	B20	N/A	-T-XXX-01-01	-T-XXX-02-01	N/A	-S-XXX-02-02	N/A	N/A	-S-XXX-01-02	-T-XXX-03-01	N/A	N/A	-S-XXX-03-02			
		4	1	N	B20	N/A	-T-XXX-01-02	-T-XXX-02-02	N/A	-S-XXX-02-01	N/A	N/A	-S-XXX-01-01	-T-XXX-03-02	N/A	N/A	-S-XXX-03-01			
-TTL	-T-XXX-02-01	1	1	1	T1	N/A	-T-XXX-01-01	-T-XXX-02-01	N/A	-S-XXX-02-02	N/A	N/A	-S-XXX-01-02	-T-XXX-03-01	N/A	N/A	-S-XXX-03-02			
		2	1	N-1	T1	-T-XXX-02-01	N/A	N/A	-T-XXX-01-01	N/A	-S-XXX-01-02	-S-XXX-02-02	N/A	N/A	-T-XXX-03-01	-S-XXX-03-02	N/A			
		3	1	N	T1	-T-XXX-02-02	N/A	N/A	-T-XXX-01-02	N/A	-S-XXX-01-01	-S-XXX-02-01	N/A	N/A	-T-XXX-03-02	-S-XXX-03-01	N/A			
		4	1	N	T1	-T-XXX-02-01	N/A	N/A	-T-XXX-01-01	N/A	-S-XXX-01-02	-S-XXX-02-01	N/A	N/A	-T-XXX-03-01	-S-XXX-03-02	N/A			
-TBR	-T-XXX-01-01	1	1	1	T1	N/A	-T-XXX-01-02	-T-XXX-02-02	N/A	-S-XXX-02-01	N/A	N/A	-S-XXX-01-01	-T-XXX-03-02	N/A	N/A	-S-XXX-03-01			
		2	1	2	T1	N/A	-T-XXX-01-01	-T-XXX-02-01	N/A	-S-XXX-02-02	N/A	N/A	-S-XXX-01-02	-T-XXX-03-01	N/A	N/A	-S-XXX-03-02			
		3	1	N-1	T1	-T-XXX-02-01	N/A	N/A	-T-XXX-01-01	N/A	-S-XXX-01-02	-S-XXX-02-02	N/A	N/A	-T-XXX-03-01	-S-XXX-03-02	N/A			
		4	1	N	T1	-T-XXX-02-02	N/A	N/A	-T-XXX-01-02	N/A	-S-XXX-01-01	-S-XXX-02-01	N/A	N/A	-T-XXX-03-02	-S-XXX-03-01	N/A			
-TBL	-T-XXX-02-01	1	1	1	B20	-T-XXX-02-02	N/A	N/A	-T-XXX-01-02	N/A	-S-XXX-01-01	-S-XXX-02-01	N/A	N/A	-T-XXX-03-02	-S-XXX-03-01	N/A			
		2	1	2	B20	-T-XXX-02-01	N/A	N/A	-T-XXX-01-01	N/A	-S-XXX-01-02	-S-XXX-02-02	N/A	N/A	-T-XXX-03-01	-S-XXX-03-02	N/A			
		3	1	N-1	B20	N/A	-T-XXX-01-01	-T-XXX-02-01	N/A	-S-XXX-02-02	N/A	N/A	-S-XXX-01-02	-T-XXX-03-01	N/A	N/A	-S-XXX-03-02			
		4	1	N	B20	N/A	-T-XXX-01-02	-T-XXX-02-02	N/A	-S-XXX-02-01	N/A	N/A	-S-XXX-01-01	-T-XXX-03-02	N/A	N/A	-S-XXX-03-01			
-STR	-S-XXX-01-01	1	1	1	B1	N/A	-T-XXX-01-01	-T-XXX-02-01	N/A	-S-XXX-02-02	N/A	N/A	-S-XXX-01-02	-T-XXX-03-01	N/A	N/A	-S-XXX-03-02			
		2	1	2	B1	N/A	-T-XXX-01-02	-T-XXX-02-02	N/A	-S-XXX-02-01	N/A	N/A	-S-XXX-01-01	-T-XXX-03-02	N/A	N/A	-S-XXX-03-01			
		3	1	N-1	B1	-T-XXX-02-02	N/A	N/A	-T-XXX-01-02	N/A	-S-XXX-01-01	-S-XXX-02-01	N/A	N/A	-T-XXX-03-01	-S-XXX-03-02	N/A			
		4	1	N	B1	-T-XXX-02-01	N/A	N/A	-T-XXX-01-01	N/A	-S-XXX-01-02	-S-XXX-02-02	N/A	N/A	-T-XXX-03-01	-S-XXX-03-02	N/A			
-STL	-S-XXX-02-01	1	1	1	T20	-T-XXX-02-01	N/A	N/A	-T-XXX-01-01	N/A	-S-XXX-01-02	-S-XXX-02-02	N/A	N/A	-T-XXX-03-01	-S-XXX-03-02	N/A			
		2	1	2	T20	-T-XXX-02-02	N/A	N/A	-T-XXX-01-02	N/A	-S-XXX-01-01	-S-XXX-02-01	N/A	N/A	-T-XXX-03-02	-S-XXX-03-01	N/A			
		3	1	N-1	T20	N/A	-T-XXX-01-02	-T-XXX-02-02	N/A	-S-XXX-02-01	N/A	N/A	-S-XXX-01-01	-T-XXX-03-02	N/A	N/A	-S-XXX-03-01			
		4	1	N	T20	N/A	-T-XXX-01-01	-T-XXX-02-01	N/A	-S-XXX-02-02	N/A	N/A	-S-XXX-01-02	-T-XXX-03-01	N/A	N/A	-S-XXX-03-02			
-SBR	-S-XXX-01-01	1	1	1	T20	-T-XXX-02-01	N/A	N/A	-T-XXX-01-01	N/A	-S-XXX-01-02	-S-XXX-02-02	N/A	N/A	-T-XXX-03-01	-S-XXX-03-02	N/A			
		2	1	2	T20	-T-XXX-02-02	N/A	N/A	-T-XXX-01-02	N/A	-S-XXX-01-01	-S-XXX-02-01	N/A	N/A	-T-XXX-03-02	-S-XXX-03-01	N/A			
		3	1	N-1	T20	N/A	-T-XXX-01-02	-T-XXX-02-02	N/A	-S-XXX-02-01	N/A	N/A	-S-XXX-01-01	-T-XXX-03-02	N/A	N/A	-S-XXX-03-01			
		4	1	N	T20	N/A	-T-XXX-01-01	-T-XXX-02-01	N/A	-S-XXX-02-02	N/A	N/A	-S-XXX-01-02	-T-XXX-03-01	N/A	N/A	-S-XXX-03-02			
-SBL	-S-XXX-02-01	1	1	1	B1	N/A	-T-XXX-01-01	-T-XXX-02-01	N/A	-S-XXX-02-02	N/A	N/A	-S-XXX-01-02	-T-XXX-03-01	N/A	N/A	-S-XXX-03-02			
		2	1	2	B1	N/A	-T-XXX-01-02	-T-XXX-02-02	N/A	-S-XXX-02-01	N/A	N/A	-S-XXX-01-01	-T-XXX-03-02	N/A	N/A	-S-XXX-03-01			
		3	1	N-1	B1	-T-XXX-02-02	N/A	N/A	-T-XXX-01-02	N/A	-S-XXX-01-01	-S-XXX-02-01	N/A	N/A	-T-XXX-03-01	-S-XXX-03-02	N/A			
		4	1	N	B1	-T-XXX-02-01	N/A	N/A	-T-XXX-01-01	N/A	-S-XXX-01-02	-S-XXX-02-02	N/A	N/A	-T-XXX-03-01	-S-XXX-03-02	N/A			
-TEU	-T-XXX-03-01	1	1	1	B20	-T-XXX-02-02	N/A	N/A	-T-XXX-01-02	N/A	-S-XXX-01-01	-S-XXX-02-01	N/A	N/A	-T-XXX-03-02	-S-XXX-03-01	N/A			
		2	1	2	B20	-T-XXX-02-01	N/A	N/A	-T-XXX-01-01	N/A	-S-XXX-01-02	-S-XXX-02-02	N/A	N/A	-T-XXX-03-01	-S-XXX-03-02	N/A			
		3	1	N-1	B20	N/A	-T-XXX-01-01	-T-XXX-02-01	N/A	-S-XXX-02-02	N/A	N/A	-S-XXX-01-02	-T-XXX-03-01	N/A	N/A	-S-XXX-03-02			
		4	1	N	B20	N/A	-T-XXX-01-02	-T-XXX-02-02	N/A	-S-XXX-02-01	N/A	N/A	-S-XXX-01-01	-T-XXX-03-02	N/A	N/A	-S-XXX-03-01			
-TED	-T-XXX-03-01	1	1	1	T1	N/A	-T-XXX-01-02	-T-XXX-02-02	N/A	-S-XXX-02-01	N/A	N/A	-S-XXX-01-01	-T-XXX-03-02	N/A	N/A	-S-XXX-03-01			
		2	1	2	T1	N/A	-T-XXX-01-01	-T-XXX-02-01	N/A	-S-XXX-02-02	N/A	N/A	-S-XXX-01-02	-T-XXX-03-01	N/A	N/A	-S-XXX-03-02			
		3	1	N-1	T1	-T-XXX-02-01	N/A	N/A	-T-XXX-01-01	N/A	-S-XXX-01-01	-S-XXX-02-01	N/A	N/A	-T-XXX-03-01	-S-XXX-03-02	N/A			
		4	1	N	T1	-T-XXX-02-02	N/A	N/A	-T-XXX-01-02	N/A	-S-XXX-01-02	-S-XXX-02-02	N/A	N/A	-T-XXX-03-01	-S-XXX-03-02	N/A			
-SEU	-S-XXX-03-01	1	1	1	B1	N/A	-T-XXX-01-01	-T-XXX-02-01	N/A	-S-XXX-02-02	N/A	N/A	-S-XXX-01-02	-T-XXX-03-01	N/A	N/A	-S-XXX-03-02			
		2	1	2	B1	N/A	-T-XXX-01-02	-T-XXX-02-02	N/A	-S-XXX-02-01	N/A	N/A	-S-XXX-01-01	-T-XXX-03-02	N/A	N/A	-S-XXX-03-01			
		3	1	N-1	B1	-T-XXX-02-02	N/A	N/A	-T-XXX-01-02	N/A	-S-XXX-01-01	-S-XXX-02-01	N/A	N/A	-T-XXX-03-01	-S-XXX-03-02	N/A			
		4	1	N	B1	-T-XXX-02-01	N/A	N/A	-T-XXX-01-01	N/A	-S-XXX-01-02	-S-XXX-02-02	N/A	N/A	-T-XXX-03-01	-S-XXX-03-02	N/A			
-SED	-S-XXX-03-01	1	1	1	T20	-T-XXX-02-01	N/A	N/A	-T-XXX-01-01	N/A	-S-XXX-01-02	-S-XXX-02-02	N/A	N/A	-T-XXX-03-01	-S-XXX-03-02	N/A			
		2	1	2	T20	-T-XXX-02-02	N/A	N/A	-T-XXX-01-02	N/A	-S-XXX-01-01	-S-XXX-02-01	N/A	N/A	-T-XXX-03-02	-S-XXX-03-01	N/A			
		3	1	N-1	T20	N/A	-T-XXX-01-02	-T-XXX-02-02	N/A	-S-XXX-02-01	N/A	N/A	-S-XXX-01-01	-T-XXX-03-02	N/A	N/A	-S-XXX-03-01			
		4	1	N	T20	N/A	-T-XXX-01-01	-T-XXX-02-01	N/A	-S-XXX-02-02	N/A	N/A	-S-XXX-01-02	-T-XXX-03-01	N/A	N/A	-S-XXX-03-02			
-TPU	-T-XXX-03-01	1	1	1	B20	-T-XXX-02-02	N/A	N/A	-T-XXX-01-02	N/A	-S-XXX-01-01	-S-XXX-02-01	N/A	N/A	-T-XXX-03-02	-S-XXX-03-01	N/A			
		2	1	2	B20	-T-XXX-02-01	N/A	N/A	-T-XXX-01-01	N/A	-S-XXX-01-02	-S-XXX-02-02	N/A	N/A	-T-XXX-03-01	-S-XXX-03-02	N/A			
		3	1	N-1	B20	N/A	-T-XXX-01-01	-T-XXX-02-01	N/A	-S-XXX-02-02	N/A	N/A	-S-XXX-01-01	-T-XXX-03-02	N/A	N/A	-S-XXX-03-01			
		4	1	N	B20	N/A	-T-XXX-01-02	-T-XXX-02-02	N/A	-S-XXX-02-01	N/A	N/A	-S-XXX-01-02	-T-XXX-03-01	N/A	N/A	-S-XXX-03-02			
-TPD	-T-XXX-03-01	1	1	1	T1	N/A	-T-XXX-01-02	-T-XXX-02-02	N/A	-S-XXX-02-01	N/A	N/A	-S-XXX-01-01	-T-XXX-03-02	N/A	N/A	-S-XXX-03-01			
		2	1	2	T1	N/A	-T-XXX-01-01	-T-XXX-02-01	N/A	-S-XXX-02-02	N/A	N/A	-S-XXX-01-02	-T-XXX-03-01	N/A	N/A	-S-XXX-03-02			
		3	1	N-1	T1	-T-XXX-02-01	N/A	N/A	-T-XXX-01-01	N/A	-S-XXX-01-01	-S-XXX-02-01	N/A	N/A	-T-XXX-03-01	-S-XXX-03-02	N/A			
		4	1	N	T1	-T-XXX-02-02	N/A	N/A	-T-XXX-01-02	N/A	-S-XXX-01-02	-S-XXX-02-02	N/A	N/A	-T-XXX-03-01	-S-XXX-03-02	N/A			
-SPU	-S-XXX-03-01	1	1	1	B1	N/A	-T-XXX-01-01	-T-XXX-02-01	N/A	-S-XXX-02-02	N/A	N/A	-S-XXX-01-02	-T-XXX-03-01	N/A	N/A	-S-XXX-03-02			
		2	1	2	B1	N/A	-T-XXX-01-02	-T-XXX-02-02	N/A	-S-XXX-02-01	N/A	N/A	-S-XXX-01-01	-T-XXX-03-02	N/A	N/A	-S-XXX-03-01			
		3	1	N-1	B1	-T-XXX-02-02	N/A	N/A	-T-XXX-01-02	N/A	-S-XXX-01-01	-S-XXX-02-01	N/A	N/A	-T-XXX-03-01	-S-XXX-03-02	N/A			
		4	1	N	B1	-T-XXX-02-01	N/A	N/A	-T-XXX-01-01	N/A	-S-XXX-01-02	-S-XXX-02-02	N/A	N/A	-T-XXX-03-01	-S-XXX-03-02	N/A			
-SPD	-S-XXX-03-01	1	1	1	T20	-T-XXX-02-01	N/A	N/A	-T-XXX-01-01	N/A	-S-XXX-01-02	-S-XXX-02-02	N/A	N/A	-T-XXX-03-01	-S-XXX-03-02	N/A			
		2	1	2	T20	-T-XXX-02-02	N/A	N/A	-T-XXX-01-02	N/A	-S-XXX-01-01	-S-XXX-02-01	N/A	N/A	-T-XXX-03-02	-S-XXX-03-01	N/A			
		3	1	N-1	T20	N/A	-T-XXX-01-02	-T-XXX-02-02	N/A	-S-XXX-02-01	N/A	N/A	-S-XXX-01-01	-T-XXX-03-02	N/A	N/A	-S-XXX-03-01			
		4	1	N	T20	N/A	-T-XXX-01-01	-T-XXX-02-01	N/A	-S-XXX-02-02	N/A	N/A	-S-XXX-01-02	-T-XXX-03-01	N/A	N/A	-S-XXX-03-02			

FOR RT1 OPTION SUB ASSEMBLY ADD -RT1 TO THE END OF THE SUB ASSEMBLY CALLOUT LISTED IN THE TABLE ABOVE.

PROPRIETARY NOTE
 THIS DOCUMENT CONTAINS CONFIDENTIAL AND PROPRIETARY INFORMATION AND ALL DESIGN, MANUFACTURING, REPRODUCTION, USE, PATENT RIGHTS AND SALES RIGHTS ARE EXPRESSLY RESERVED BY SAMTEC, INC. THIS DOCUMENT SHALL NOT BE DISCLOSED, IN WHOLE OR PART, TO ANY UNAUTHORIZED PERSON OR ENTITY NOR REPRODUCED, TRANSFERRED OR INCORPORATED IN ANY OTHER PROJECT IN ANY MANNER WITHOUT THE EXPRESS WRITTEN CONSENT OF SAMTEC, INC.



520 PARK EAST BLVD, NEW ALBANY, IN 47150
 PHONE: 812-944-6733 FAX: 812-948-5047
 e-Mail: info@SAMTEC.com code: 55322



DO NOT SCALE DRAWING

SHEET SCALE: 1:25:1

DESCRIPTION:	0.8mm HIGH-SPEED COAX CABLE ASSEMBLY
DWG. NO.	EQCD-XXX-XX.XX-XXX-XXX-X-X
BY: KEVIN B	02/19/03
	SHEET 7 OF 7

Looking for pricing, stock, or lifecycle information?

Click below to explore more details on WIN SOURCE:

-  [View EQCD-020-15.00-TBL-TED-1-B on WIN SOURCE](#)
-  [Samtec Inc. Information](#)

Optimize Your Supply Chain with WIN SOURCE Solutions

-  Global Sourcing Solution
-  Obsolete Management
-  Cost Control Management
-  Shortage Management
-  Alternative Solution
-  Excess Inventory Management