



**THE DATASHEET OF
MXL692-AM-T**



General Description

The MxL692 is a single-chip, integrated tuner and demodulator receiver that targets digital TV, single/multi-channel STB, USB/WiFi adapter, and WiFi/wired/RF Smart antenna system applications for the *Advanced Television Systems Committee ATSC* standard and cable applications for the global digital cable standards *ITU-T J.83 Annexes (A, B, and C)*.

The MxL692 takes an RF input signal from 44 MHz to 1006 MHz, and outputs an MPEG TS in serial or parallel format. With its high-level of integration, the chip integrates the following to simplify the board-level design:

- Broadband input filter
- Channel filter
- AGC
- LO
- PLL
- Demodulators

The device comes in a small 5 × 5 mm QFN package, enabling a very compact design, reduced BOM cost, and lower power consumption.

The MxL692 is controlled through an I2C interface. The IC supports either single supply operation using 3.3V, or dual supply operation using 3.3V and 1.8V.

Applications

- Single-channel ATSC zapper
- Dual-channel PVR STB
- Quad-channel PVR STB
- ATSC/QAM gateway
- ATSC to USB/WiFi adapter
- ATSC wired/RF Smart antenna

Features

- Wide tuning range from 44 MHz to 1006 MHz
- Single RF input
- Integrated channel filtering that does not require SAW filters, and has programmable channel bandwidths of either 6 MHz or 8 MHz
- Loop-through (LT) output function
- On-chip voltage regulators enable a single supply operation
- Typical low-power consumption of <550 mW for ATSC and <450 mW for QAM in dual supply operation
- Excellent immunity to LTE and WiFi interference
- Automatic spectral inversion in QAM modes
- Input power reporting
- Serial or parallel TS interface
- *CEA-909* compliant *Smart Antenna Interface Specification* (modes A and B)
- API-based software interface

Supported Standards

- ATSC A/53
- ITU-T J.83
 - Annex A (DVB-C)
 - Annex B (US Cable)
 - Annex C (Japan)

Block Diagram

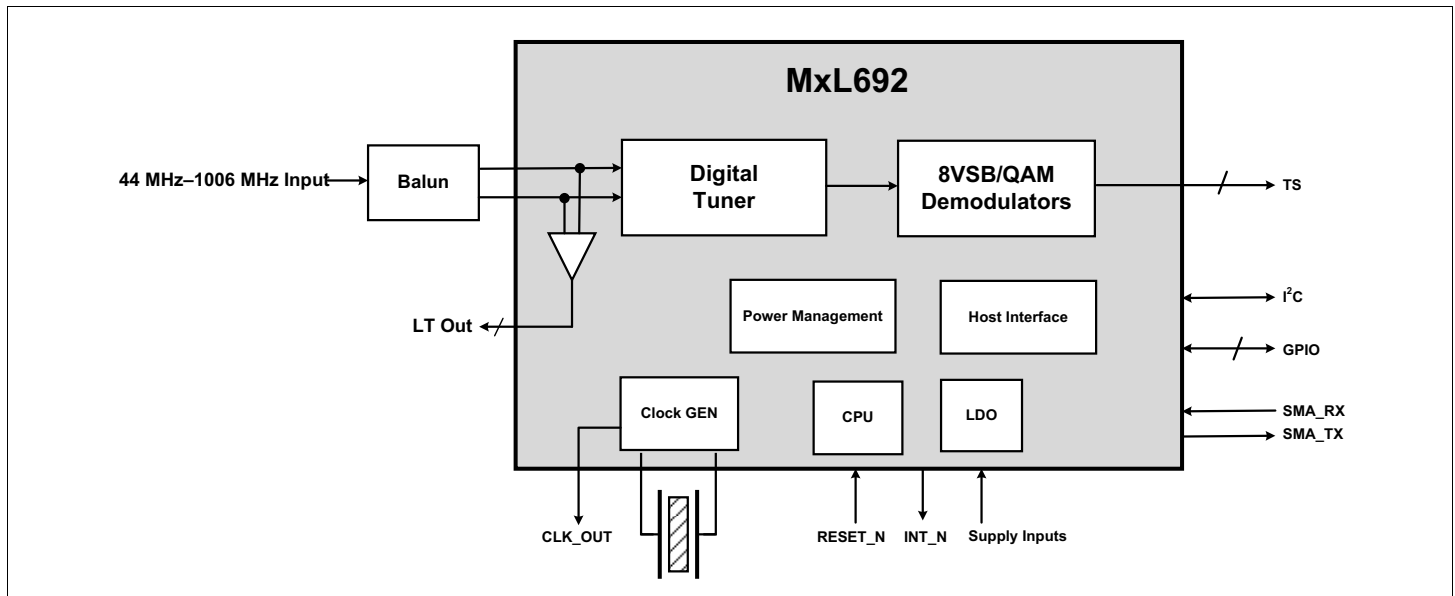

Ordering Information

| Marketing Part Number | Ordering Part Number | Package | Dimension | Shipping |
|-----------------------|----------------------|---------|-----------------------|---------------|
| MxL692 | MxL692-AM-T | QFN40 | 5 mm × 5 mm × 0.85 mm | Tray |
| MxL692 | MxL692-AM-R | QFN40 | 5 mm × 5 mm × 0.85 mm | Tape and Reel |



MaxLinear, Inc.
 5966 La Place Court, Suite 100
 Carlsbad, CA 92008
 760.692.0711 p.
 760.444.8598 f.
www.maxlinear.com

The content of this document is furnished for informational use only, is subject to change without notice, and should not be construed as a commitment by MaxLinear, Inc. MaxLinear, Inc. assumes no responsibility or liability for any errors or inaccuracies that may appear in the informational content contained in this guide. Complying with all applicable copyright laws is the responsibility of the user. Without limiting the rights under copyright, no part of this document may be reproduced into, stored in, or introduced into a retrieval system, or transmitted in any form or by any means (electronic, mechanical, photocopying, recording, or otherwise), or for any purpose, without the express written permission of MaxLinear, Inc.

MaxLinear, Inc. does not recommend the use of any of its products in life support applications where the failure or malfunction of the product can reasonably be expected to cause failure of the life support system or to significantly affect its safety or effectiveness. Products are not authorized for use in such applications unless MaxLinear, Inc. receives, in writing, assurances to its satisfaction that: (a) the risk of injury or damage has been minimized; (b) the user assumes all such risks; (c) potential liability of MaxLinear, Inc. is adequately protected under the circumstances.

MaxLinear, Inc. may have patents, patent applications, trademarks, copyrights, or other intellectual property rights covering subject matter in this document. Except as expressly provided in any written license agreement from MaxLinear, Inc., the furnishing of this document does not give you any license to these patents, trademarks, copyrights, or other intellectual property.

MaxLinear, the MaxLinear logo, and any MaxLinear trademarks, MxL, Full-Spectrum Capture, FSC, G.now, AirPHY and the MaxLinear logo are all on the products sold, are all trademarks of MaxLinear, Inc. or one of MaxLinear's subsidiaries in the U.S.A. and other countries. All rights reserved. Other company trademarks and product names appearing herein are the property of their respective owners.

Looking for pricing, stock, or lifecycle information?

Click below to explore more details on WIN SOURCE:

- [View MXL692-AM-T on WIN SOURCE](#)
- [MaxLinear Inc Information](#)

Optimize Your Supply Chain with WIN SOURCE Solutions

- ✓ Global Sourcing Solution
- ✓ Obsolete Management
- ✓ Cost Control Management
- ✓ Shortage Management
- ✓ Alternative Solution
- ✓ Excess Inventory Management