



# COP8AME9 8-Bit CMOS Flash Microcontroller with 8k Memory, Dual Op Amps, Virtual EEPROM, Temperature Sensor, 10-Bit A/D and Brownout Reset

Check for Samples: [COP8AME9](#), [COP8ANE9](#)

## FEATURES

### KEY FEATURES

- 8 kbytes Flash Program Memory with High Security
- 512 bytes SRAM
- 10-bit Successive Approximation Analog to Digital Converter (up to 6 external channels)
- Op Amp Specification:
  - One Programmable Gain (1, 2, 5, 10, 20, 49, 98) with Adjustable Offset Voltage Nulling
  - One General Purpose with all I/O Terminals Accessible
  - 1 MHz GBW
  - Low Offset Voltage
  - High Input Impedance
  - Rail-to-rail input/output
- Temperature Sensing Diode
- True In-System Programmability of Flash Memory with 100k Erase/Write Cycles
- Dual Clock Operation providing Enhanced Power Save Modes – HALT/IDLE
- 100% Precise Analog Emulation
- Single Supply Operation: 4.5V–5.5V
- Three 16-bit Timers:
  - Timers T2 and T3 Can Operate at 50 ns Resolution
  - Processor Independent PWM Mode
  - External Event Counter Mode
  - Input Capture Mode
- Brownout Reset
- 20 High Sink-Current I/Os
- USART
- Virtual EEPROM Using Flash Program Memory
- 7 Input Analog MUX with Selectable Output Destination

### OTHER FEATURES

- Quiet Design (Low Radiated Emissions)
- Multi-Input Wake-up with optional interrupts
- MICROWIRE/PLUS (Serial Peripheral Interface Compatible)
- Clock Doubler for 20 MHz Operation from 10 MHz Oscillator
- Thirteen Multi-Source Vectored Interrupts Servicing:
  - External Interrupt
  - USART (2)
  - Idle Timer T0
  - Three Timers (each with 2 interrupts)
  - MICROWIRE/PLUS Serial Peripheral Interface
  - Multi-Input Wake-Up
  - Software Trap
- Idle Timer with Programmable Interrupt Interval
- 8-bit Stack Pointer SP (Stack in RAM)
- Two 8-bit Register Indirect Data Memory Pointers
- True Bit Manipulation
- WATCHDOG and Clock Monitor logic
- Software Selectable I/O Options
  - TRI-STATE Output/High Impedance Input
  - Push-Pull Output
  - Weak Pull-Up Input
- Schmitt Trigger Inputs on I/O Ports
- Temperature Range: –40°C to +85°C
- Packaging: 28 DIP, and 28 SOIC



Please be aware that an important notice concerning availability, standard warranty, and use in critical applications of Texas Instruments semiconductor products and disclaimers thereto appears at the end of this data sheet.

COP8 is a trademark of Texas Instruments.

All other trademarks are the property of their respective owners.

### DESCRIPTION

The COP8AME9 Flash microcontroller is a highly integrated COP8™ Feature core device, with 8k Flash memory and advanced features including Virtual EEPROM, dual Op Amps (one programmable gain), temperature sensor, A/D, High Speed Timers, USART, and Brownout Reset. The COP8AME9 has True In-System Programmable Flash memory with high-endurance (100k erase/write cycles), and is well suited for applications requiring real-time data collection and processing, multiple sensory interface, and remote monitoring. The same device is used for development, pre-production and volume production with a range of COP8 software and hardware development tools.

Table 1. Device Described in This Data Sheet:

Device	Flash Program Memory (bytes)	RAM (bytes)	Brownout Voltage	I/O Pins	Packages	Temperature
COP8AME9	8k	512	4.17 to 4.5V	21	28 DIP/SOIC	-40°C to +85°C

### Block Diagram

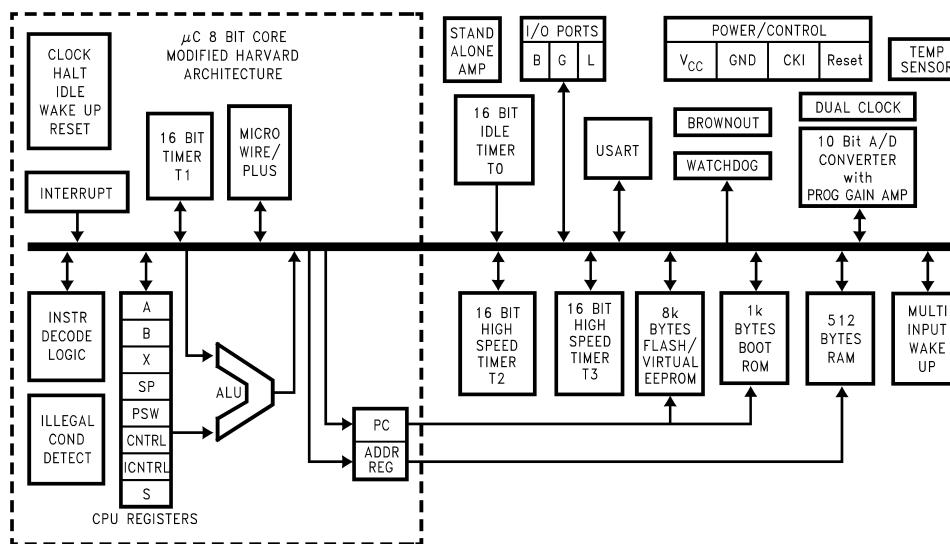

### Connection Diagram

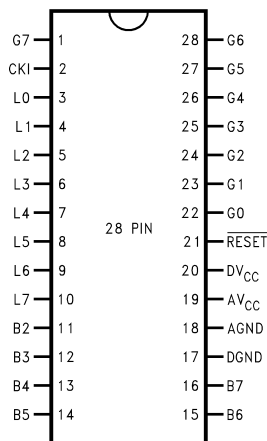

Figure 1. Top View

**Table 2. Pinouts for 28-Pin Packages**

Port	Type	Alt. Fun	In System Emulation Mode	28-Pin DIP/SOIC
L0	I/O	MIWU or Low Speed OSC In		3
L1	I/O	MIWU or CKX or Low Speed OSC Out		4
L2	I/O	MIWU or TDX		5
L3	I/O	MIWU or RDX		6
L4	I/O	MIWU or T2A		7
L5	I/O	MIWU or T2B		8
L6	I/O	MIWU or T3A		9
L7	I/O	MIWU or T3B		10
G0	I/O	INT	Input	22
G1	I/O	WDOUT <sup>(1)</sup>	POUT	23
G2	I/O	T1B	Output	24
G3	I/O	T1A	Clock	25
G4	I/O	SO		26
G5	I/O	SK		27
G6	I	SI		28
G7	I	CKO		1
B2	I/O	ADCH10		11
B3	I/O	ADCH11 or AMP1 Output		12
B4	I/O	ADCH12 or AMP1 – Input		13
B5	I/O	ADCH13 or AMP1 + Input		14
B6	I/O	ADCH14 or A/D MUX OUT		15
B7	I/O	ADCH15 or A/D IN		16
DV <sub>CC</sub>			V <sub>CC</sub>	20
DGND			GND	17
AV <sub>CC</sub>				19
AGND				18
CKI	I			2
$\overline{\text{RESET}}$	I		$\overline{\text{RESET}}$	21

(1) G1 operation as WDOUT is controlled by Option Register bit 2.

## Architectural Overview

### EMI REDUCTION

The COP8AME9 device incorporates circuitry that guards against electromagnetic interference - an increasing problem in today's microcontroller board designs. TI's patented EMI reduction technology offers low EMI clock circuitry, gradual turn-on output drivers (GTOs) and internal Icc smoothing filters, to help circumvent many of the EMI issues influencing embedded control designs. TI has achieved 15 dB–20 dB reduction in EMI transmissions when designs have incorporated its patented EMI reducing circuitry.

### IN-SYSTEM PROGRAMMING AND VIRTUAL EEPROM

The device includes a program in a boot ROM that provides the capability, through the MICROWIRE/PLUS serial interface, to erase, program and read the contents of the Flash memory.

Additional routines are included in the boot ROM, which can be called by the user program, to enable the user to customize in-system software update capability if MICROWIRE/PLUS is not desired.

Additional functions will copy blocks of data between the RAM and the Flash Memory. These functions provide a virtual EEPROM capability by allowing the user to emulate a variable amount of EEPROM by initializing nonvolatile variables from the Flash Memory and occasionally restoring these variables to the Flash Memory.

The contents of the boot ROM have been defined by TI. Execution of code from the boot ROM is dependent on the state of the FLEX bit in the Option Register on exit from RESET. If the FLEX bit is a zero, the Flash Memory is assumed to be empty and execution from the boot ROM begins. For further information on the FLEX bit, refer to Section 4.5, Option Register.

## DUAL CLOCK AND CLOCK DOUBLER

The device includes a versatile clocking system and two oscillator circuits designed to drive a crystal or ceramic resonator. The primary oscillator operates at high speed up to 10 MHz. The secondary oscillator is optimized for operation at 32.768 kHz.

The user can, through specified transition sequences (please refer to [Power Saving Features](#)), switch execution between the high speed and low speed oscillators. The unused oscillator can then be turned off to minimize power dissipation. If the low speed oscillator is not used, the pins are available as general purpose bidirectional ports.

The operation of the CPU will use a clock at twice the frequency of the selected oscillator (up to 20 MHz for high speed operation and 65.536 kHz for low speed operation). This doubled clock will be referred to in this document as 'MCLK'. The frequency of the selected oscillator will be referred to as CKI. Instruction execution occurs at one tenth the selected MCLK rate.

## TRUE IN-SYSTEM EMULATION

On-chip emulation capability has been added, which allows the user to perform true in-system emulation using final production boards and devices. This simplifies testing and evaluation of software in real environmental conditions. The user, merely by providing for a standard connector which can be bypassed by jumpers on the final application board, can provide for software and hardware debugging using actual production units.

## ARCHITECTURE

The COP8 family is based on a modified Harvard architecture, which allows data tables to be accessed directly from program memory. This is very important with modern microcontroller-based applications, since program memory is usually ROM, EPROM or Flash, while data memory is usually RAM. Consequently constant data tables need to be contained in non-volatile memory, so they are not lost when the microcontroller is powered down. In a modified Harvard architecture, instruction fetch and memory data transfers can be overlapped with a two stage pipeline, which allows the next instruction to be fetched from program memory while the current instruction is being executed using data memory. This is not possible with a Von Neumann single-address bus architecture.

The COP8 family supports a software stack scheme that allows the user to incorporate many subroutine calls. This capability is important when using High Level Languages. With a hardware stack, the user is limited to a small fixed number of stack levels.

## INSTRUCTION SET

In today's 8-bit microcontroller application arena cost/performance, flexibility and time to market are several of the key issues that system designers face in attempting to build well-engineered products that compete in the marketplace. Many of these issues can be addressed through the manner in which a microcontroller's instruction set handles processing tasks. And that's why the COP8 family offers a unique and code-efficient instruction set - one that provides the flexibility, functionality, reduced costs and faster time to market that today's microcontroller based products require.

Code efficiency is important because it enables designers to pack more on-chip functionality into less program memory space (ROM, OTP or Flash). Selecting a microcontroller with less program memory size translates into lower system costs, and the added security of knowing that more code can be packed into the available program memory space.

### **Key Instruction Set Features**

The COP8 family incorporates a unique combination of instruction set features, which provide designers with optimum code efficiency and program memory utilization.

### **Single Byte/Single Cycle Code Execution**

The efficiency is due to the fact that the majority of instructions are of the single byte variety, resulting in minimum program space. Because compact code does not occupy a substantial amount of program memory space, designers can integrate additional features and functionality into the microcontroller program memory space. Also, the majority instructions executed by the device are single cycle, resulting in minimum program execution time. In fact, 77% of the instructions are single byte single cycle, providing greater code and I/O efficiency, and faster code execution.

### **Many Single-Byte, Multi-Function Instructions**

The COP8 instruction set utilizes many single-byte, multifunction instructions. This enables a single instruction to accomplish multiple functions, such as DRSZ, DCOR, JID, LD (Load) and X (Exchange) instructions with post-incrementing and post-decrementing, to name just a few examples. In many cases, the instruction set can simultaneously execute as many as three functions with the same single-byte instruction.

JID: (Jump Indirect); Single byte instruction decodes external events and jumps to corresponding service routines (analogous to “DO CASE” statements in higher level languages).

LAID: (Load Accumulator-Indirect); Single byte look up table instruction provides efficient data path from the program memory to the CPU. This instruction can be used for table lookup and to read the entire program memory for checksum calculations.

RETSK: (Return Skip); Single byte instruction allows return from subroutine and skips next instruction. Decision to branch can be made in the subroutine itself, saving code.

AUTOINC/DEC: (Auto-Increment/Auto-Decrement); These instructions use the two memory pointers B and X to efficiently process a block of data (simplifying “FOR NEXT” or other loop structures in higher level languages).

### **Bit-Level Control**

Bit-level control over many of the microcontroller's I/O ports provides a flexible means to ease layout concerns and save board space. All members of the COP8 family provide the ability to set, reset and test any individual bit in the data memory address space, including memory-mapped I/O ports and associated registers.

### **Register Set**

Three memory-mapped pointers handle register indirect addressing and software stack pointer functions. The memory data pointers allow the option of post-incrementing or post-decrementing with the data movement instructions (LOAD/EXCHANGE). And 15 memory-mapped registers allow designers to optimize the precise implementation of certain specific instructions.

### **PACKAGING/PIN EFFICIENCY**

Real estate and board configuration considerations demand maximum space and pin efficiency, particularly given today's high integration and small product form factors. Microcontroller users try to avoid using large packages to get the I/O needed. Large packages take valuable board space and increases device cost, two trade-offs that microcontroller designs can ill afford.

The COP8 family offers a wide range of packages and does not waste pins: up to 85.7% are devoted to useful I/O.



These devices have limited built-in ESD protection. The leads should be shorted together or the device placed in conductive foam during storage or handling to prevent electrostatic damage to the MOS gates.

### Absolute Maximum Ratings <sup>(1)(2)</sup>

Supply Voltage ( $V_{CC}$ )	7V
Voltage at Any Pin	-0.3V to $V_{CC} + 0.3V$
Total Current into $V_{CC}$ Pin (Source)	200 mA
Total Current out of GND Pin (Sink)	200 mA
Storage Temperature Range	-65°C to +140°C
ESD Protection Level	2 kV (Human Body Model)

- (1) Absolute maximum ratings indicate limits beyond which damage to the device may occur. DC and AC electrical specifications are not ensured when operating the device at absolute maximum ratings.
- (2) If Military/Aerospace specified devices are required, please contact the Texas Instruments Sales Office/Distributors for availability and specifications.

### Electrical Characteristics DC Electrical Characteristics ( $-40^{\circ}\text{C} \leq T_A \leq +85^{\circ}\text{C}$ )

Datasheet min/max specification limits are ensured by design, test, or statistical analysis.

Parameter	Conditions	Min	Typ	Max	Units
Operating Voltage		4.5		5.5	V
Power Supply Rise Time		10		$50 \times 10^6$	ns
Power Supply Ripple <sup>(1)</sup>	Peak-to-Peak			$0.1 V_{CC}$	V
Supply Current on $V_{CC}$ pin <sup>(2)</sup>					
High Speed Mode					
CKI = 10 MHz	$V_{CC} = 5.5V, t_C = 0.5 \mu s$			14.5	mA
CKI = 3.33 MHz	$V_{CC} = 4.5V, t_C = 1.5 \mu s$			7	mA
Dual Clock Mode					
CKI = 10 MHz, Low Speed OSC = 32 kHz	$V_{CC} = 5.5V, t_C = 0.5 \mu s$			14.5	mA
CKI = 3.33 MHz, Low Speed OSC = 32 kHz	$V_{CC} = 4.5V, t_C = 1.5 \mu s$			7	mA
Low Speed Mode					
Low Speed OSC = 32 kHz	$V_{CC} = 5.5V$		60	103	$\mu A$
HALT Current with BOR Disabled (Test Mode only) <sup>(3)</sup>					
High Speed Mode	$V_{CC} = 5.5V, CKI = 0 \text{ MHz}$		<1	10	$\mu A$
Dual Clock Mode	$V_{CC} = 5.5V, CKI = 0 \text{ MHz},$ Low Speed OSC = 32 kHz		<5	17	$\mu A$
Low Speed Mode	$V_{CC} = 5.5V, CKI = 0 \text{ MHz},$ Low Speed OSC = 32 kHz		<5	17	$\mu A$
Idle Current on $V_{CC}$ pin <sup>(2)</sup>					
High Speed Mode					
CKI = 10 MHz	$V_{CC} = 5.5V, t_C = 0.5 \mu s$			2.5	mA
CKI = 3.33 MHz	$V_{CC} = 4.5V, t_C = 1.5 \mu s$			1.2	mA
Dual Clock Mode					
CKI = 10 MHz, Low Speed OSC = 32 kHz	$V_{CC} = 5.5V, t_C = 0.5 \mu s$			2.5	mA
CKI = 3.33 MHz, Low Speed OSC = 32 kHz	$V_{CC} = 4.5V, t_C = 1.5 \mu s$			1.2	mA
Low Speed Mode					
Low Speed OSC = 32 kHz	$V_{CC} = 5.5V$		15	30	$\mu A$
Supply Current for BOR Feature	$V_{CC} = 5.5V$			45	$\mu A$

- (1) Maximum rate of voltage change must be  $< 0.5 \text{ V/ms}$ .
- (2) Supply and IDLE currents are measured with CKI driven with a square wave Oscillator, CKO driven 180° out of phase with CKI, inputs connected to  $V_{CC}$  and outputs driven low but not connected to a load.
- (3) The HALT mode will stop CKI from oscillating. Measurement of  $I_{DD \text{ HALT}}$  is done with device neither sourcing nor sinking current; with L, B, G0, and G2–G5 programmed as low outputs and not driving a load; all inputs tied to  $V_{CC}$ ; A/D converter and clock monitor and BOR disabled. Parameter refers to HALT mode entered via setting bit 7 of the G Port data register.

**Electrical Characteristics DC Electrical Characteristics ( $-40^{\circ}\text{C} \leq T_A \leq +85^{\circ}\text{C}$ ) (continued)**

Datasheet min/max specification limits are ensured by design, test, or statistical analysis.

Parameter	Conditions	Min	Typ	Max	Units
Brownout Trip Level		4.17	4.28	4.5	V
Input Levels ( $V_{IH}$ , $V_{IL}$ )					
Logic High		$0.8 V_{CC}$			V
Logic Low				$0.16 V_{CC}$	V
Internal Bias Resistor for the CKI Crystal/Resonator Oscillator		0.3	1.0	2.5	MΩ
Hi-Z Input Leakage	$V_{CC} = 5.5\text{V}$	-0.5		+0.5	μA
Input Pullup Current	$V_{CC} = 5.5\text{V}$ , $V_{IN} = 0\text{V}$	-50		-210	μA
Port Input Hysteresis		$0.25 V_{CC}$			V
Output Current Levels					
Source (Weak Pull-Up Mode)	$V_{CC} = 4.5\text{V}$ , $V_{OH} = 3.8\text{V}$	-10			μA
Source (Push-Pull Mode)	$V_{CC} = 4.5\text{V}$ , $V_{OH} = 3.8\text{V}$	-7			mA
Sink (Push-Pull Mode) <sup>(4)</sup>	$V_{CC} = 4.5\text{V}$ , $V_{OL} = 1.0\text{V}$	10			mA
Allowable Sink Current per Pin				15	mA
TRI-STATE Leakage	$V_{CC} = 5.5\text{V}$	-0.5		+0.5	μA
Maximum Input Current without Latchup <sup>(5)</sup>				±200	mA
RAM Retention Voltage, $V_R$ (in HALT Mode)		2.0			V
Input Capacitance				7	pF
Voltage on G6 to force execution from Boot ROM <sup>(6)</sup>	G6 rise time must be slower than 100 ns	$2 \times V_{CC}$		$V_{CC} + 7$	V
G6 Rise Time to force execution from Boot ROM		100			nS
Input Current on G6 when Input > $V_{CC}$	$V_{IN} = 11\text{V}$ , $V_{CC} = 5.5\text{V}$		500		μA
Flash Endurance			100k		cycles
Flash Data Retention	25°C		100		years

(4) Absolute Maximum Ratings should not be exceeded.

(5) Pins G6 and RESET are designed with a high voltage input network. These pins allow input voltages >  $V_{CC}$  and the pins will have sink current to  $V_{CC}$  when biased at voltages >  $V_{CC}$  (the pins do not have source current when biased at a voltage below  $V_{CC}$ ). These two pins will not latch up. The voltage at these pins must be limited to < ( $V_{CC} + 7\text{V}$ ). **WARNING: Voltages in excess of ( $V_{CC} + 7\text{V}$ ) will cause damage to these pins. This warning excludes ESD transients.**

(6)  $V_{CC}$  must be valid and stable before G6 is raised to a high voltage.

## AC Electrical Characteristics ( $-40^{\circ}\text{C} \leq T_A \leq +85^{\circ}\text{C}$ )

Datasheet min/max specification limits are ensured by design, test, or statistical analysis.

Parameter	Conditions	Min	Typ	Max	Units
Instruction Cycle Time ( $t_c$ )					
Crystal/Resonator	$4.5\text{V} \leq V_{CC} \leq 5.5\text{V}$	0.5		DC	$\mu\text{s}$
Frequency of MICROWIRE/PLUS in Slave Mode				2	MHz
MICROWIRE/PLUS Setup Time ( $t_{UWS}$ )		20			ns
MICROWIRE/PLUS Hold Time ( $t_{UWH}$ )		20			ns
MICROWIRE/PLUS Output Propagation Delay ( $t_{UPD}$ )				150	ns
Input Pulse Width					
Interrupt Input High Time		1			$t_c$
Interrupt Input Low Time		1			$t_c$
Timer 1 Input High Time		1			$t_c$
Timer 1 Input Low Time		1			$t_c$
Timer 2, 3 Input High Time <sup>(1)</sup>		1			MCLK or $t_c$
Timer 2, 3 Input Low Time <sup>(1)</sup>		1			MCLK or $t_c$
Output Pulse Width					
Timer 2, 3 Output High Time		150			ns
Timer 2, 3 Output Low Time		150			ns
USART Bit Time when using External CKX		6 CKI periods			
USART CKX Frequency when being Driven by Internal Baud Rate Generator				2	MHz
Reset Pulse Width		0.5			$\mu\text{s}$
Flash Memory Mass Erase Time		8			ms
Flash Memory Page Erase Time	See Table 15, Typical Flash Memory Endurance		1		ms

(1) If timer is in high speed mode, the minimum time is 1 MCLK. If timer is not in high speed mode, the minimum time is 1  $t_c$ .

**A/D Converter Electrical Characteristics ( $-20^{\circ}\text{C} \leq T_A \leq +85^{\circ}\text{C}$ ) (Single-ended mode only)**

Datasheet min/max specification limits are ensured by design, test, or statistical analysis.

Parameter	Conditions	Min	Typ	Max	Units
Resolution				10	Bits
DNL	$V_{CC} = 5V$			$\pm 1$	LSB
INL	$V_{CC} = 5V$			$\pm 2.5$	LSB
Offset Error	$V_{CC} = 5V$			$\pm 1.5$	LSB
Gain Error	$V_{CC} = 5V$			+0.5/-2.0	LSB
Input Voltage Range	$4.5V \leq V_{CC} \leq 5.5V$	0		$V_{CC}$	V
Analog Input Leakage Current				0.5	$\mu\text{A}$
Analog Input Resistance <sup>(1)</sup>				6k	$\Omega$
Analog Input Capacitance				7	pF
Conversion Clock Period	$4.5V \leq V_{CC} \leq 5.5V$	0.8		30	$\mu\text{s}$
Conversion Time (Including S/H Time)			15		A/D Conversion Clock Cycles
Operating Current on $AV_{CC}$	$AV_{CC} = 5.5V$		0.2	0.6	mA

(1) Resistance between the device input and the internal sample and hold capacitance.

**Stand-alone Amplifier Electrical Characteristics ( $4.5V \leq AV_{CC} \leq 5.5V$ ,  $-40^{\circ}C \leq T_A \leq +85^{\circ}C$ )**

Datasheet min/max specification limits are ensured by design, test, or statistical analysis.

Parameter	Conditions	Min	Typ	Max	Units
Input Offset Voltage		-7		+7	mV
Input Common Mode Capacitance			10		pF
Common Mode Rejection Ratio (CMRR)	$0V \leq V_{CM} \leq V_{CC}$	50			dB
Power Supply Rejection Ratio (PSRR)	$V_{CM} = V_{CC}/2$	70			dB
Common Mode Voltage Range (CMVR)	$CMRR \geq 45dB$	-0.2		$V_{CC} + 0.2$	V
Large Signal Voltage Gain	$R_L = 2k$ to $V_{CC}/2$ , $V_{CM} = V_{CC}/2$ $0.5 \leq V_O \leq V_{CC} - 0.5V$	70	85		dB
Output Swing High	$R_L = 2k$ to $V_{CC}/2$ , $V_{id} = 100$ mV	$V_{CC} - 70$			mV
Output Swing Low	$R_L = 2k$ to $V_{CC}/2$ , $V_{id} = 100$ mV			80	mV
Output Short Circuit Current <sup>(1)</sup>	$V_O = GND$ , $V_{id} = 100$ mV	20			mA
Output Short Circuit Current <sup>(1)</sup>	$V_O = V_{CC}$ , $V_{id} = 100$ mV	15			mA
Supply Current on $AV_{CC}$ when enabled	$AV_{CC} = 5.5$ V, No Load		315	500	$\mu$ A
Enable Time				15	$\mu$ S
Disable Time				1	$\mu$ S
Slew Rate <sup>(2)</sup>	Gain = 1, $R_L = 10k$ , $C_L < 350$ pF $V_{in} = 2V$ square wave	1.0	1.5		V/ $\mu$ S
Unity Gain Frequency	$R_L = 2k$ to $V_{CC}/2$		2.0		Mhz
Input Referred Voltage Noise			55		$\frac{nV}{\sqrt{Hz}}$ (1)
Total Harmonic Distortion (THD)	$f = 1kHz$ , $AV = 1$ , $V_o = 2.2$ Vpp, $R_L = 600\Omega$ to $V_{CC}/2$		0.2		%

(1) Short circuit test is a momentary test. Extended period output short circuit may damage the device.

(2) Slew rate is the slower of the rising and falling slew rates.

**Programmable Gain Amplifier Electrical Characteristics ( $4.5V \leq AV_{CC} \leq 5.5V$ ,  $-40^{\circ}C \leq T_A \leq +85^{\circ}C$ )**

Datasheet min/max specification limits are ensured by design, test, or statistical analysis.

Parameter	Conditions	Min	Typ	Max	Units
Input Offset Voltage Untrimmed		-7		+7	mV
Input Offset Voltage Trimmed		-0.5		-0.5	mV
Common Mode Rejection Ratio Untrimmed (CMRR)	$0V \leq V_{CM} \leq V_{CC}$	50			dB
Common Mode Rejection Ratio Trimmed (CMRR)	$0V \leq V_{CM} \leq V_{CC}$	70			dB
Power Supply Rejection Ratio (PSRR)	$V_{CM} = V_{CC}/2$	70			dB
Output Swing High	$V_{IN} = V_{CC}$ , Gain = 1	$V_{CC} - 8$			mV
Output Swing Low	$V_{IN} = 0$ , Gain = 1			0.7	mV
Supply Current on $AV_{CC}$ when enabled	$AV_{CC} = 5.5V$		315	500	$\mu A$
Enable Time				40	$\mu S$
Disable Time				1	$\mu S$
Slew Rate <sup>(1)</sup>	See Table in A/D Section for conditions that are slew rate limited	1.0	1.5		V/ $\mu S$
Programmable Gain Tolerance (Trimmed)	Gain = 1,2,5, Gain = 10, 20, 49, 98			$\pm 1$ $\pm 2$	% %

(1) Slew rate is the slower of the rising and falling slew rates.

**Temperature Sensor Electrical Characteristics ( $-40^{\circ}C \leq T_A \leq +85^{\circ}C$ )**

Datasheet min/max specification limits are ensured by design, test, or statistical analysis.

Parameter	Conditions	Min	Typ	Max	Units
Output Voltage at $0^{\circ}C$	$2.7V \leq AV_{CC} \leq 5.5V$		1.65		V
Deviation from Equation		-12		+12	$^{\circ}C$
Line Regulation			TBD		mV/V
Enable time				350	$\mu S$
Quiescent Current on $AV_{CC}$ when enabled	$AV_{CC} = 5.5V$			300	$\mu A$

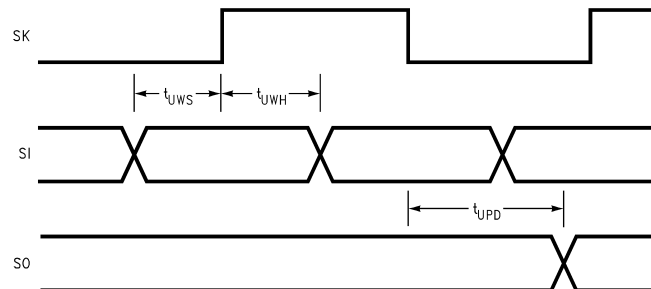

Figure 2. MICROWIRE/PLUS Timing

## Pin Functions

The COP8AME9 I/O structure enables designers to reconfigure the microcontroller's I/O functions with a single instruction. Each individual I/O pin can be independently configured as output pin low, output high, input with high impedance or input with weak pull-up device. A typical example is the use of I/O pins as the keyboard matrix input lines. The input lines can be programmed with internal weak pull-ups so that the input lines read logic high when the keys are all open. With a key closure, the corresponding input line will read a logic zero since the weak pull-up can easily be overdriven. When the key is released, the internal weak pull-up will pull the input line back to logic high. This eliminates the need for external pull-up resistors. The high current options are available for driving LEDs, motors and speakers. This flexibility helps to ensure a cleaner design, with less external components and lower costs. Below is the general description of all available pins.

$V_{CC}$  and GND are the power supply pins. All  $V_{CC}$  and GND pins must be connected.

CKI is the clock input. This can be connected (in conjunction with CKO) to an external crystal circuit to form a crystal oscillator. See Oscillator Description section.

$\overline{\text{RESET}}$  is the master reset input. See Reset description section.

$AV_{CC}$  is the Analog Supply for A/D converter. It should be connected to  $V_{CC}$  externally.

AGND is the ground pin for the A/D converter. It should be connected to GND externally.

The device contains up to three bidirectional 8-bit I/O ports (B, G and L) where each individual IO may be independently configured as an input (Schmitt trigger inputs on ports L and G), output or TRI-STATE under program control. Three data memory address locations are allocated for each of these I/O ports. Each I/O port has three associated 8-bit memory mapped registers, the CONFIGURATION register, the output DATA register and the Pin input register. (See the memory map for the various addresses associated with the I/O ports.) [Figure 3](#) shows the I/O port configurations. The DATA and CONFIGURATION registers allow for each port bit to be individually configured under software control as shown below:

**Pin Descriptions**

CONFIGURATION Register	DATA Register	Port Set-Up
0	0	Hi-Z Input
		(TRI-STATE Output)
0	1	Input with Weak Pull-Up
1	0	Push-Pull Zero Output
1	1	Push-Pull One Output

Port B is a 6-bit I/O port. All B pins have Schmitt triggers on the inputs. The 28-pin packages do not have a full 8-bit port and contain some unbonded, floating pads internally on the chip. The binary value read from these bits is undetermined. The application software should mask out these unknown bits when reading the Port B register, or use only bit-access program instructions when accessing Port B. These unconnected bits draw power only when they are addressed (i.e., in brief spikes). Additionally, if Port B is being used with some combination of digital inputs and analog inputs, the analog inputs will read as undetermined values and should be masked out by software.

Port B supports the analog inputs for the A/D converter. Port B has the following alternate pin functions:

- B7** Analog Channel 15 or A/D Input
- B6** Analog Channel 14 or Analog Multiplexor Output
- B5** Analog Channel 13 or AMP1 + Input
- B4** Analog Channel 12 or AMP1 – Input
- B3** Analog Channel 11 or AMP1 Output
- B2** Analog Channel 10

Port G is an 8-bit port. Pin G0, G2–G5 are bi-directional I/O ports. Pin G6 is always a general purpose Hi-Z input. All pins have Schmitt Triggers on their inputs. **Pin G1 serves as the dedicated WATCHDOG output with weak pull-up if the WATCHDOG feature is selected by the Option register. The pin is a general purpose I/O if WATCHDOG feature is not selected.** If WATCHDOG feature is selected, bit 1 of the Port G configuration and data register does not have any effect on Pin G1 setup.

G7 serves as the dedicated output pin for the CKO clock output.

There are two registers associated with the G Port, a data register and a configuration register. Therefore, each of the 6 I/O bits (G0 - G5) can be individually configured under software control.

Since G6 is an input only pin and G7 is the dedicated CKO clock output pin, the associated bits in the data and configuration registers for G6 and G7 are used for special purpose functions as outlined below. Reading the G6 and G7 data bits will return zeros.

The chip is placed in the HALT mode by writing a "1" to bit 7 of the Port G Data register. Similarly the chip will be placed in the IDLE mode by writing a "1" to bit 6 of the Port G Data Register.

Writing a "1" to bit 6 of the Port G Configuration Register enables the MICROWIRE/PLUS to operate with the alternate phase of the SK clock.

	Config. Reg.	Data Reg.
G7	Not Used	HALT
G6	Alternate SK	IDLE

Port G has the following alternate features:

- G7** CKO Oscillator dedicated output
- G6** SI (MICROWIRE/PLUS Serial Data Input)
- G5** SK (MICROWIRE/PLUS Serial Clock)
- G4** SO (MICROWIRE/PLUS Serial Data Output)
- G3** T1A (Timer T1 I/O)
- G2** T1B (Timer T1 Capture Input)
- G1** WDOUT WATCHDOG and/or Clock Monitor if WATCHDOG enabled, otherwise it is a general purpose I/O
- G0** INTR (External Interrupt Input)

G0 through G3 are also used for In-System Emulation.

Port L is an 8-bit I/O port. All L-pins have Schmitt triggers on the inputs.

Port L supports the Multi-Input Wake-Up feature on all eight pins. Port L has the following alternate pin functions:

- L7** Multi-Input Wake-up or T3B (Timer T3B Input)
- L6** Multi-Input Wake-up or T3A (Timer T3A Input/Output)
- L5** Multi-Input Wake-up or T2B (Timer T2B Input)
- L4** Multi-Input Wake-up or T2A (Timer T2A Input/Output)
- L3** Multi-Input Wake-up and/or RDX (USART Receive)
- L2** Multi-Input Wake-up or TDX (USART Transmit)
- L1** Multi-Input Wake-up and/or CKX (USART Clock) (Low Speed Oscillator Output)
- L0** Multi-Input Wake-up (Low Speed Oscillator Input)

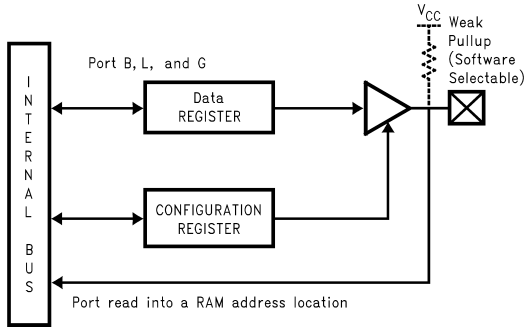

Figure 3. I/O Port Configurations

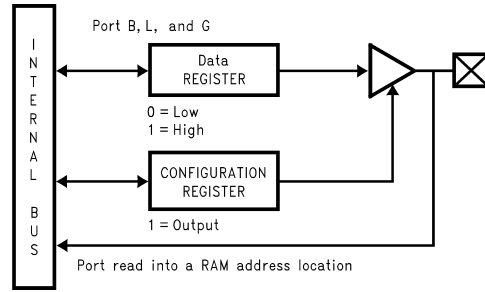

Figure 4. I/O Port Configurations—Output Mode

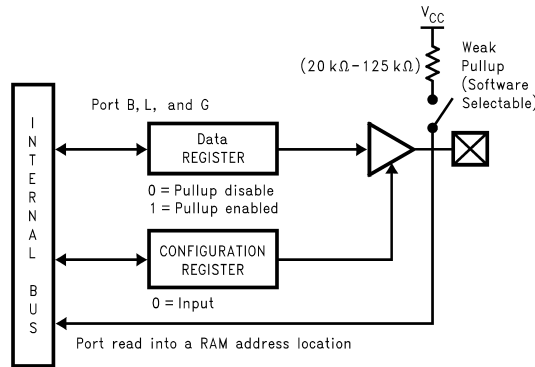

Figure 5. I/O Port Configurations—Input Mode

**EMULATION CONNECTION**

Connection to the emulation system is made via a 2 x 7 connector which interrupts the continuity of the RESET, G0, G1, G2 and G3 signals between the COP8 device and the rest of the target system (as shown in Figure 6). This connector can be designed into the production PC board and can be replaced by jumpers or signal traces when emulation is no longer necessary.

The emulator will replicate all functions of G0 - G3 and Reset. For proper operation, no connection should be made on the device side of the emulator connector.

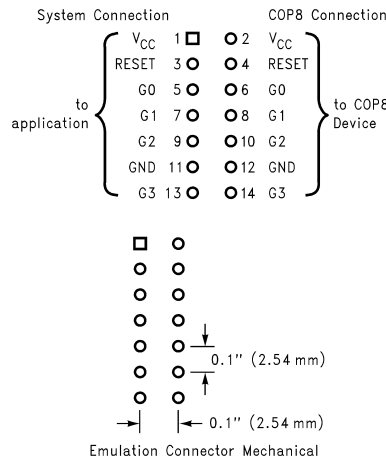

Figure 6. Emulation Connection

## Functional Description

The architecture of the device is a modified Harvard architecture. With the Harvard architecture, the program memory (Flash) is separate from the data store memory (RAM). Both Program Memory and Data Memory have their own separate addressing space with separate address buses. The architecture, though based on the Harvard architecture, permits transfer of data from Flash Memory to RAM.

## CPU REGISTERS

The CPU can do an 8-bit addition, subtraction, logical or shift operation in one instruction ( $t_c$ ) cycle time.

There are six CPU registers:

A is the 8-bit Accumulator Register

PC is the 15-bit Program Counter Register

PU is the upper 7 bits of the program counter (PC)

PL is the lower 8 bits of the program counter (PC)

B is an 8-bit RAM address pointer, which can be optionally post auto incremented or decremented.

X is an 8-bit alternate RAM address pointer, which can be optionally post auto incremented or decremented.

S is the 8-bit Data Segment Address Register used to extend the lower half of the address range (00 to 7F) into 256 data segments of 128 bytes each.

SP is the 8-bit stack pointer, which points to the subroutine/interrupt stack (in RAM). With reset the SP is initialized to RAM address 06F Hex. The SP is decremented as items are pushed onto the stack. SP points to the next available location on the stack.

All the CPU registers are memory mapped with the exception of the Accumulator (A) and the Program Counter (PC).

## PROGRAM MEMORY

The program memory consists of 8192 bytes of Flash Memory. These bytes may hold program instructions or constant data (data tables for the LAID instruction, jump vectors for the JID instruction, and interrupt vectors for the VIS instruction). The program memory is addressed by the 15-bit program counter (PC). All interrupts in the device vector to program memory location 00FF Hex. The contents of the program memory read 00 Hex in the erased state. Program execution starts at location 0 after RESET.

If a Return instruction is executed when the SP contains 6F (hex), instruction execution will continue from Program Memory location 1FFF (hex). If location 1FFF is accessed by an instruction fetch, the Flash Memory will return a value of 00. This is the opcode for the INTR instruction and will cause a Software Trap.

For the purpose of erasing and rewriting the Flash Memory, it is organized in pages of 64 bytes.

Refer to [Table 3](#) for program memory size and available address ranges.

**Table 3. Available Memory Address Ranges**

Device	Program Memory Size (Flash)	Flash Memory Page Size (Bytes)	Option Register Address (Hex)	Data Memory Size (RAM)	Segments Available	Maximum RAM Address (HEX)
COP8AME9	8192	64	1FFF	512	0-3	037F

## DATA MEMORY

The data memory address space includes the on-chip RAM and data registers, the I/O registers (Configuration, Data and Pin), the control registers, the MICROWIRE/PLUS SIO shift register, and the various registers, and counters associated with the timers and the USART (with the exception of the IDLE timer). Data memory is addressed directly by the instruction or indirectly by the B, X and SP pointers.

The data memory consists of 512 bytes of RAM. Sixteen bytes of RAM are mapped as “registers” at addresses 0F0 to 0FF Hex. These registers can be loaded immediately, and also decremented and tested with the DRSZ (decrement register and skip if zero) instruction. The memory pointer registers X, SP, B and S are memory mapped into this space at address locations 0FC to 0FF Hex respectively, with the other registers being available for general usage.

The instruction set permits any bit in memory to be set, reset or tested. All I/O and registers (except A and PC) are memory mapped; therefore, I/O bits and register bits can be directly and individually set, reset and tested. The accumulator (A) bits can also be directly and individually tested.

Note: RAM contents are undefined upon power-up.

### DATA MEMORY SEGMENT RAM EXTENSION

Data memory address 0FF is used as a memory mapped location for the Data Segment Address Register (S).

The data store memory is either addressed directly by a single byte address within the instruction, or indirectly relative to the reference of the B, X, or SP pointers (each contains a single-byte address). This single-byte address allows an addressing range of 256 locations from 00 to FF hex. The upper bit of this single-byte address divides the data store memory into two separate sections as outlined previously. With the exception of the RAM register memory from address locations 00F0 to 00FF, all RAM memory is memory mapped with the upper bit of the single-byte address being equal to zero. This allows the upper bit of the single-byte address to determine whether or not the base address range (from 0000 to 00FF) is extended. If this upper bit equals one (representing address range 0080 to 00FF), then address extension does not take place. Alternatively, if this upper bit equals zero, then the data segment extension register S is used to extend the base address range (from 0000 to 007F) from XX00 to XX7F, where XX represents the 8 bits from the S register. Thus the 128-byte data segment extensions are located from addresses 0100 to 017F for data segment 1, 0200 to 027F for data segment 2, etc., up to FF00 to FF7F for data segment 255. The base address range from 0000 to 007F represents data segment 0. Refer to [Table 3](#) to determine available RAM segments for this device.

[Figure 7](#) illustrates how the S register data memory extension is used in extending the lower half of the base address range (00 to 7F hex) into 256 data segments of 128 bytes each, with a total addressing range of 32 kbytes from XX00 to XX7F. This organization allows a total of 256 data segments of 128 bytes each with an additional upper base segment of 128 bytes. Furthermore, all addressing modes are available for all data segments. The S register must be changed under program control to move from one data segment (128 bytes) to another. However, the upper base segment (containing the 16 memory registers, I/O registers, control registers, etc.) is always available regardless of the contents of the S register, since the upper base segment (address range 0080 to 00FF) is independent of data segment extension.

The instructions that utilize the stack pointer (SP) always reference the stack as part of the base segment (Segment 0), regardless of the contents of the S register. The S register is not changed by these instructions. Consequently, the stack (used with subroutine linkage and interrupts) is always located in the base segment. The stack pointer will be initialized to point at data memory location 006F as a result of reset.

The 128 bytes of RAM contained in the base segment are split between the lower and upper base segments. The first 112 bytes of RAM are resident from address 0000 to 006F in the lower base segment, while the remaining 16 bytes of RAM represent the 16 data memory registers located at addresses 00F0 to 00FF of the upper base segment. No RAM is located at the upper sixteen addresses (0070 to 007F) of the lower base segment.

Additional RAM beyond these initial 128 bytes, however, will always be memory mapped in groups of 128 bytes (or less) at the data segment address extensions (XX00 to XX7F) of the lower base segment.

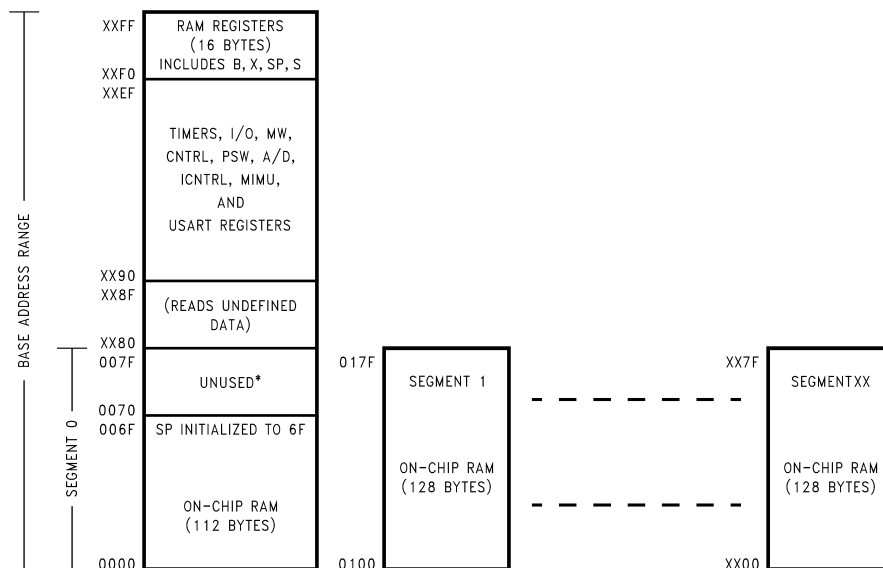

Figure 7. RAM Organization

**Virtual EEPROM**

The Flash memory and the User ISP functions (see Section 5.7), provide the user with the capability to use the flash program memory to back up user defined sections of RAM. This effectively provides the user with the same nonvolatile data storage as EEPROM. Management, and even the amount of memory used, are the responsibility of the user, however the flash memory read and write functions have been provided in the boot ROM.

One typical method of using the Virtual EEPROM feature would be for the user to copy the data to RAM during system initialization, periodically, and if necessary, erase the page of Flash and copy the contents of the RAM back to the Flash.

**OPTION REGISTER**

The Option register, located at address 0x1FFF in the Flash Program Memory, is used to configure the user selectable security, WATCHDOG, and HALT options. The register can be programmed only in external Flash Memory programming or ISP Programming modes. Therefore, the register must be programmed at the same time as the program memory. The contents of the Option register shipped from the factory read 00 Hex.

The format of the Option register is as follows:

Bit 7	Bit 6	Bit 5	Bit 4	Bit 3	Bit 2	Bit 1	Bit 0
Reserved		SECURITY	Reserved		WATCH DOG	HALT	FLEX

**Bits 7, 6** These bits are reserved and must be 0.

**Bit 5**

- = 1 Security enabled. Flash Memory read and write are not allowed except in User ISP/Virtual E<sup>2</sup> commands. Mass Erase is allowed.
- = 0 Security disabled. Flash Memory read and write are allowed.

**Bits 4, 3** These bits are reserved and must be 0.

**Bit 2**

- = 1 WATCHDOG feature disabled. G1 is a general purpose I/O.
- = 0 WATCHDOG feature enabled. G1 pin is WATCHDOG output with weak pullup.

**Bit 1**

- = 1 HALT mode disabled.
- = 0 HALT mode enabled.

**Bit 0**

- = 1 Execution following RESET will be from Flash Memory.
- = 0 Flash Memory is erased. Execution following RESET will be from Boot ROM with the MICROWIRE/PLUS ISP routines.

The COP8 assembler defines a special ROM section type, CONF, into which the Option Register data may be coded. The Option Register is programmed automatically by programmers that are certified by TI.

The user needs to ensure that the FLEX bit will be set when the device is programmed.

The following examples illustrate the declaration of the Option Register.

**Syntax:**

```
[label:].sect      config, conf
.db               value      ;1 byte,
;configures
;options
.endsect
```

**Example:** The following sets a value in the Option Register for a COP8AME9. The Option Register bit values shown select options: Security disabled, WATCHDOG enabled HALT mode enabled and execution will commence from Flash Memory.

```
.chip           8AME
.sect          option, conf
.db           0x01      ;wd, halt, flex
.endsect
...
.end          start
```

**Note:** All programmers certified for programming this family of parts will support programming of the Option Register. Please contact TI or your device programmer supplier for more information.

**SECURITY**

The device has a security feature which, when enabled, prevents external reading of the Flash program memory. The security bit in the Option Register determines, whether security is enabled or disabled. If the security feature is disabled, the contents of the internal Flash Memory may be read by external programmers or by the built in MICROWIRE/PLUS serial interface ISP. **Security must be enforced by the user when the contents of the Flash Memory are accessed via the user ISP or Virtual EEPROM capability.**

If the security feature is enabled, then any attempt to externally read the contents of the Flash Memory will result in the value FF (hex) being read from all program locations (except the Option Register). In addition, with the security feature enabled, the write operation to the Flash program memory and Option Register is inhibited. Page Erases are also inhibited when the security feature is enabled. The Option Register is readable regardless of the state of the security bit by accessing location FFFF (hex). Mass Erase Operations are possible regardless of the state of the security bit.

The security bit can be erased only by a Mass Erase of the entire contents of the Flash unless Flash operation is under the control of User ISP functions.

**Note:** The actual memory address of the Option Register is 1FFF (hex), however the MICROWIRE/PLUS ISP routines require the address FFFF (hex) to be used to read the Option Register when the Flash Memory is secured.

The entire Option Register must be programmed at one time and cannot be rewritten without first erasing the entire last page of Flash Memory.

**RESET**

The device is initialized when the  $\overline{\text{RESET}}$  pin is pulled low or the On-chip Brownout Reset is activated.

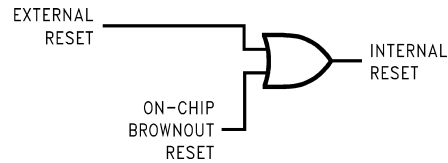

**Figure 8. Reset Logic**

The following occurs upon initialization:

Port B: TRI-STATE (High Impedance Input)

Port G: TRI-STATE (High Impedance Input). Exceptions: If Watchdog is enabled, then G1 is Watchdog output. G0 and G2 have their weak pull-up enabled during RESET.

Port L: TRI-STATE (High Impedance Input)

PC: CLEARED to 0000

PSW, CNTRL and ICNTRL registers: CLEARED

SIOR:

UNAFFFECTED after RESET with power already applied

RANDOM after RESET at power-on

T2CNTRL: CLEARED

T3CNTRL: CLEARED

HSTCR: CLEARED

ITMR: Cleared except Bit 6 (HSON) = 1

Accumulator, Timer 1, Timer 2 and Timer 3:

RANDOM after RESET

WKEN, WKEDG: CLEARED

WKPND: RANDOM

SP (Stack Pointer):

Initialized to RAM address 06F Hex

B and X Pointers:

UNAFFFECTED after RESET with power already applied

RANDOM after RESET at power-on

S Register: CLEARED

RAM:

UNAFFFECTED after RESET with power already applied

RANDOM after RESET at power-on

USART:

PSR, ENU, ENUR, ENUI: Cleared, except the TBMT bit which is set to one.

ANALOG TO DIGITAL CONVERTER:

ENAD: CLEARED

ADRSTH: RANDOM

ADRSTL: RANDOM

Op Amp:

AMPTRMN, AMPTRMP: Cleared, except bit 6 = 1

ADGAIN: CLEARED

ISP CONTROL:

ISPADLO: CLEARED

ISPADHI: CLEARED

PGMTIM: PRESET TO VALUE FOR 10 MHz CKI

WATCHDOG (if enabled):

The device comes out of reset with both the WATCHDOG logic and the Clock Monitor detector armed, with the WATCHDOG service window bits set and the Clock Monitor bit set. The WATCHDOG and Clock Monitor circuits are inhibited during reset. The WATCHDOG service window bits being initialized high default to the maximum WATCHDOG service window of 64k T<sub>0</sub> clock cycles. The Clock Monitor bit being initialized high will cause a Clock Monitor error following reset if the clock has not reached the minimum specified frequency at the termination of reset. A Clock Monitor error will cause an active low error output on pin G1. This error output will continue until 16–32 T<sub>0</sub> clock cycles following the clock frequency reaching the minimum specified value, at which time the G1 output will go high.

### External Reset

The  $\overline{\text{RESET}}$  input, when pulled low, initializes the device. The  $\overline{\text{RESET}}$  pin must be held low for a minimum of one instruction cycle to ensure a valid reset.

$\overline{\text{RESET}}$  may also be used to cause an exit from the HALT mode.

A recommended reset circuit for this device is shown in [Figure 9](#).

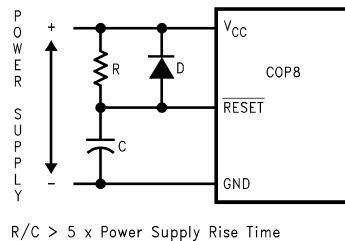

**Figure 9. Reset Circuit Using External Reset**

### On-Chip Brownout Reset

The device generates an internal reset as  $V_{CC}$  rises. While  $V_{CC}$  is less than the specified brownout voltage ( $V_{bor}$ ), the device is held in the reset condition and the Idle Timer is preset with 00F<sub>x</sub> (240–256  $t_c$ ). When  $V_{CC}$  reaches a value greater than  $V_{bor}$ , the Idle Timer starts counting down. Upon underflow of the Idle Timer, the internal reset is released and the device will start executing instructions. This internal reset will perform the same functions as external reset. Once  $V_{CC}$  is above  $V_{bor}$ , and this initial Idle Timer time-out takes place, instruction execution begins and the Idle Timer can be used normally. If, however,  $V_{CC}$  drops below  $V_{bor}$ , an internal reset is generated, and the Idle Timer is preset with 00F<sub>x</sub>. The device now waits until  $V_{CC}$  is greater than  $V_{bor}$  and the countdown starts over. The functional operation of the device is specified down to the  $V_{bor}$  level.

One exception to the above is that the brownout circuit will insert a delay of approximately 3 ms on power up or any time the  $V_{CC}$  drops below a voltage of about 1.8V. The device will be held in Reset for the duration of this delay before the Idle Timer starts counting the 240 to 256  $t_c$ . This delay starts as soon as the  $V_{CC}$  rises above the trigger voltage (approximately 1.8V). This behavior is shown in [Figure 10](#).

In Case 1,  $V_{CC}$  rises from 0V and the on-chip  $\overline{\text{RESET}}$  is undefined until the supply is greater than approximately 1.0V. At this time the brownout circuit becomes active and holds the device in  $\overline{\text{RESET}}$ . As the supply passes a level of about 1.8V, a delay of about 3 ms ( $t_d$ ) is started and the Idle Timer is preset to a value between 00F0 and 00FF (hex). Once  $V_{CC}$  is greater than  $V_{bor}$  and  $t_d$  has expired, the Idle Timer is allowed to count down ( $t_d$ ).

Case 2 shows a subsequent dip in the supply voltage which goes below the approximate 1.8V level. As  $V_{CC}$  drops below  $V_{bor}$ , the internal RESET signal is asserted. When  $V_{CC}$  rises back above the 1.8V level,  $t_d$  is started. Since the power supply rise time is longer for this case,  $t_d$  has expired before  $V_{CC}$  rises above  $V_{bor}$  and  $t_{id}$  starts immediately when  $V_{CC}$  is greater than  $V_{bor}$ .

Case 3 shows a dip in the supply where  $V_{CC}$  drops below  $V_{bor}$ , but not below 1.8V. On-chip RESET is asserted when  $V_{CC}$  goes below  $V_{bor}$  and  $t_{id}$  starts as soon as the supply goes back above  $V_{bor}$ .

The internal reset will not be turned off until the Idle Timer underflows. The internal reset will perform the same functions as external reset. The device is ensured to operate at the specified frequency down to the specified brownout voltage. After the underflow, the logic is designed such that no additional internal resets occur as long as  $V_{CC}$  remains above the brownout voltage.

The device is relatively immune to short duration negative-going  $V_{CC}$  transients (glitches). It is essential that good filtering of  $V_{CC}$  be done to ensure that the brownout feature works correctly. Power supply decoupling is vital even in battery powered systems.

Refer to the device specifications for the actual  $V_{bor}$  voltage.

Under no circumstances should the  $\overline{RESET}$  pin be allowed to float. If the external Reset feature is not being used, the RESET pin should be connected directly to  $V_{CC}$ . The RESET input may also be connected to an external pull-up resistor or to other external circuitry. The output of the brownout reset detector will always preset the Idle Timer to a value between 00F0 and 00FF (240 to 256  $t_C$ ). At this time, the internal reset will be generated.

The contents of data registers and RAM are unknown following the on-chip reset.

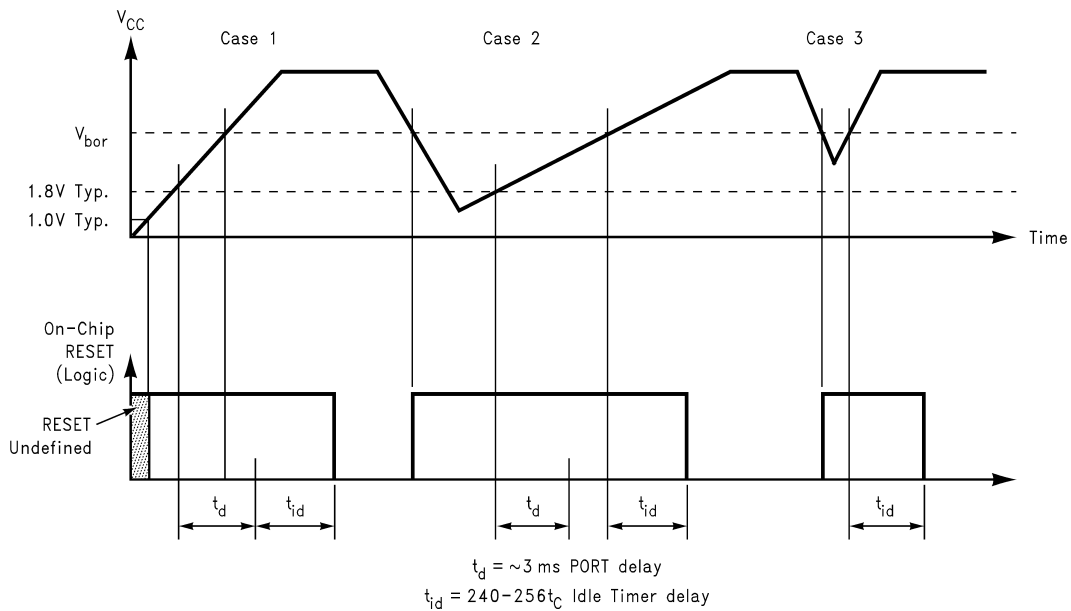

Figure 10. Brownout Reset Operation

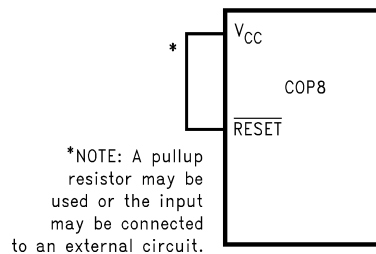

Figure 11. Reset Circuit Using Power-On Reset

## OSCILLATOR CIRCUITS

The device has two crystal oscillators to facilitate low power operation while maintaining throughput when required. Further information on the use of the two oscillators is found in Section 7.0 Power Saving Features. The low speed oscillator utilizes the L0 and L1 port pins. References in the following text to CKI will also apply to L0 and references to G7/CKO will also apply to L1.

### Oscillator

CKI is the clock input while G7/CKO is the clock generator output to the crystal. An on-chip bias resistor connected between CKI and CKO is provided to reduce system part count. The value of the resistor is in the range of 0.5M to 2M (typically 1.0M). Table 4 shows the component values required for various standard crystal values. Resistor R2 is on-chip, for the high speed oscillator, and is shown for reference. Figure 13 shows the crystal oscillator connection diagram. A ceramic resonator of the required frequency may be used in place of a crystal if the accuracy requirements are not quite as strict.

**Table 4. Crystal Oscillator Configuration,**  
 $T_A = 25^\circ\text{C}$ ,  $V_{CC} = 5\text{V}$

R1 (k $\Omega$ )	R2 (M $\Omega$ )	C1 (pF)	C2 (pF)	CKI Freq. (MHz)
0	On Chip	18	18	10
0	On Chip	18	18	5
0	On Chip	18–36	18–36	1
5.6	On Chip	100	100–156	0.455
0	20	**	**	32.768 kHz <sup>(1)</sup>

(1) Applies to connection to low speed oscillator on port pins L0 and L1 only.

\*\* See NOTE below.

The crystal and other oscillator components should be placed in close proximity to the CKI and CKO pins to minimize printed circuit trace length.

The values for the external capacitors should be chosen to obtain the manufacturer's specified load capacitance for the crystal when combined with the parasitic capacitance of the trace, socket, and package (which can vary from 0 to 8 pF). The guideline in choosing these capacitors is:

Manufacturer's specified load cap =  $(C_1 * C_2) / (C_1 + C_2) + C_{\text{parasitic}}$

$C_2$  can be trimmed to obtain the desired frequency.  $C_2$  should be less than or equal to  $C_1$ .

**Note:** The low power design of the low speed oscillator makes it extremely sensitive to board layout and load capacitance. The user should place the crystal and load capacitors within 1cm. of the device and must ensure that the above equation for load capacitance is strictly followed. If these conditions are not met, the application may have problems with startup of the low speed oscillator.

**Table 5. Startup Times**

CKI Frequency	Startup Time
10 MHz	1–10 ms
3.33 MHz	3–10 ms
1 MHz	3–20 ms
455 kHz	10–30 ms
32 kHz (low speed oscillator)	2–5 sec

### Clock Doubler

This device contains a frequency doubler that doubles the frequency of the oscillator selected to operate the main microcontroller core. The details of how to select either the high speed oscillator or low speed oscillator are described in, Power Saving Features. When the high speed oscillator connected to CKI operates at 10 MHz, the internal clock frequency is 20 MHz, resulting in an instruction cycle time of 0.5  $\mu\text{s}$ . When the 32 kHz oscillator connected to L0 and L1 is selected, the internal clock frequency is 64 kHz, resulting in an instruction cycle of 152.6  $\mu\text{s}$ . The output of the clock doubler is called MCLK and is referenced in many places within this document.

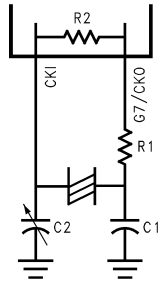
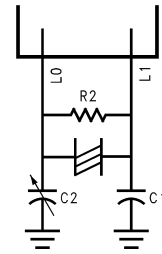
**Figure 12. High-Speed Crystal Oscillator**

**Figure 13. Low Speed Crystal Oscillator**

## CONTROL REGISTERS

### **CNTRL Register (Address X'00EE)**

T1C3	T1C2	T1C1	T1C0	MSEL	IEDG	SL1	SL0
Bit 7						Bit 0	

The Timer1 (T1) and MICROWIRE/PLUS control register contains the following bits:

**T1C3** Timer T1 mode control bit

**T1C2** Timer T1 mode control bit

**T1C1** Timer T1 mode control bit

**T1C0** Timer T1 Start/Stop control in timer modes 1 and 2. T1 Underflow Interrupt Pending Flag in timer mode 3

**MSEL** Selects G5 and G4 as MICROWIRE/PLUS signals SK and SO respectively

**IEDG** External interrupt edge polarity select (0 = Rising edge, 1 = Falling edge)

**SL1 & SL0** Select the MICROWIRE/PLUS clock divide by (00 = 2, 01 = 4, 1x = 8)

### **PSW Register (Address X'00EF)**

HC	C	T1PND A	T1ENA	EXPND	BUSY	EXEN	GIE
Bit 7						Bit 0	

The PSW register contains the following select bits:

**HC** Half Carry Flag

**C** Carry Flag

**T1PND A** Timer T1 Interrupt Pending Flag (Autoreload RA in mode 1, T1 Underflow in Mode 2, T1A capture edge in mode 3)

**T1ENA** Timer T1 Interrupt Enable for Timer Underflow or T1A Input capture edge

**EXPND** External interrupt pending

**BUSY** MICROWIRE/PLUS busy shifting flag

**EXEN** Enable external interrupt

**GIE** Global interrupt enable (enables interrupts)

The Half-Carry flag is also affected by all the instructions that affect the Carry flag. The SC (Set Carry) and R/C (Reset Carry) instructions will respectively set or clear both the carry flags. In addition to the SC and R/C instructions, ADC, SUBC, RRC and RLC instructions affect the Carry and Half Carry flags.

**ICNTRL Register (Address X'00E8)**

Unused	LPEN	T0PND	T0EN	μWPND	μWEN	T1PNDB	T1ENB
Bit 7							Bit 0

The ICNTRL register contains the following bits:

- LPEN** L Port Interrupt Enable (Multi-Input Wake-up/Interrupt)
- T0PND** Timer T0 Interrupt pending
- T0EN** Timer T0 Interrupt Enable (Bit 12 toggle)
- μWPND** MICROWIRE/PLUS interrupt pending
- μWEN** Enable MICROWIRE/PLUS interrupt
- T1PNDB** Timer T1 Interrupt Pending Flag for T1B capture edge
- T1ENB** Timer T1 Interrupt Enable for T1B Input capture edge

**T2CNTRL Register (Address X'00C6)**

T2C3	T2C2	T2C1	T2C0	T2PNDA	T2ENA	T2PNDB	T2ENB
Bit 7							Bit 0

The T2CNTRL register contains the following bits:

- T2C3** Timer T2 mode control bit
- T2C2** Timer T2 mode control bit
- T2C1** Timer T2 mode control bit
- T2C0** Timer T2 Start/Stop control in timer modes 1 and 2, Timer T2 Underflow Interrupt Pending Flag in timer mode 3
- T2PNDA** Timer T2 Interrupt Pending Flag (Autoreload RA in mode 1, T2 Underflow in mode 2, T2A capture edge in mode 3)
- T2ENA** Timer T2 Interrupt Enable for Timer Underflow or T2A Input capture edge
- T2PNDB** Timer T2 Interrupt Pending Flag for T2B capture edge
- T2ENB** Timer T2 Interrupt Enable for T2B Input capture edge

**T3CNTRL Register (Address X'00B6)**

T3C3	T3C2	T3C1	T3C0	T3PNDA	T3ENA	T3PNDB	T3ENB
Bit 7							Bit 0

The T3CNTRL register contains the following bits:

- T3C3** Timer T3 mode control bit
- T3C2** Timer T3 mode control bit
- T3C1** Timer T3 mode control bit
- T3C0** Timer T3 Start/Stop control in timer modes 1 and 2, Timer T3 Underflow Interrupt Pending Flag in timer mode 3
- T3PNDA** Timer T3 Interrupt Pending Flag (Autoreload RA in mode 1, T3 Underflow in mode 2, T3A capture edge in mode 3)
- T3ENA** Timer T3 Interrupt Enable for Timer Underflow or T3A Input capture edge
- T3PNDB** Timer T3 Interrupt Pending Flag for T3B capture edge
- T3ENB** Timer T3 Interrupt Enable for T3B Input capture edge

**HSTCR Register (Address X'00AF)**

T2IDLE	Reserved			T3HS	T2HS
Bit 7					Bit 0

The HSTCR register contains the following bits:

**T2IDLE** Allows T2 to run while in Idle Mode.

**T3HS** Places Timer T3 in High Speed Mode.

**T2HS** Places Timer T2 in High Speed Mode.

**ITMR Register (Address X'00CF)**

LSON	HSON	DCEN	CCKSEL	RSVD	ITSEL2	ITSEL1	ITSEL0
Bit 7							Bit 0

The ITMR register contains the following bits:

**LSON** Turns the low speed oscillator on or off.

**HSON** Turns the high speed oscillator on or off.

**DCEN** Selects the high speed oscillator or the low speed oscillator as the Idle Timer Clock.

**CCKSEL** Selects the high speed oscillator or the low speed oscillator as the primary CPU clock.

**RSVD** This bit is reserved and must be 0.

**ITSEL2** Idle Timer period select bit.

**ITSEL1** Idle Timer period select bit.

**ITSEL0** Idle Timer period select bit.

**ENAD Register (Address X'00CB)**

ADCH3	ADCH2	ADCH1	ADCH0	ADMOD	MUX	PSC	ADBSY
Channel Select				Mode Select	Mux Out	Prescale	Busy
Bit 7							Bit 0

The ENAD register contains the following bits:

**ADCH3** ADC channel select bit

**ADCH2** ADC channel select bit

**ADCH1** ADC channel select bit

**ADCH0** ADC channel select bit

**ADMOD** Places the ADC in single-ended or differential mode.

**MUX** Enables the ADC multiplexor output.

**PSC** Switches the ADC clock between a divide by one or a divide by sixteen of MCLK.

**ADBSY** Signifies that the ADC is currently busy performing a conversion. When set by the user, starts a conversion.

## In-System Programming

### INTRODUCTION

This device provides the capability to program the program memory while installed in an application board. This feature is called In System Programming (ISP). It provides a means of ISP by using the MICROWIRE/PLUS, or the user can provide his own, customized ISP routine. The factory installed ISP uses the MICROWIRE/PLUS port. The user can provide his own ISP routine that uses any of the capabilities of the device, such as USART, parallel port, etc.

### FUNCTIONAL DESCRIPTION

The organization of the ISP feature consists of the user flash program memory, the factory boot ROM, and some registers dedicated to performing the ISP function. See [Figure 14](#) for a simplified block diagram. The factory installed ISP that uses MICROWIRE/PLUS is located in the Boot ROM. The size of the Boot ROM is 1K bytes and also contains code to facilitate in system emulation capability. If a user chooses to write his own ISP routine, it must be located in the flash program memory.

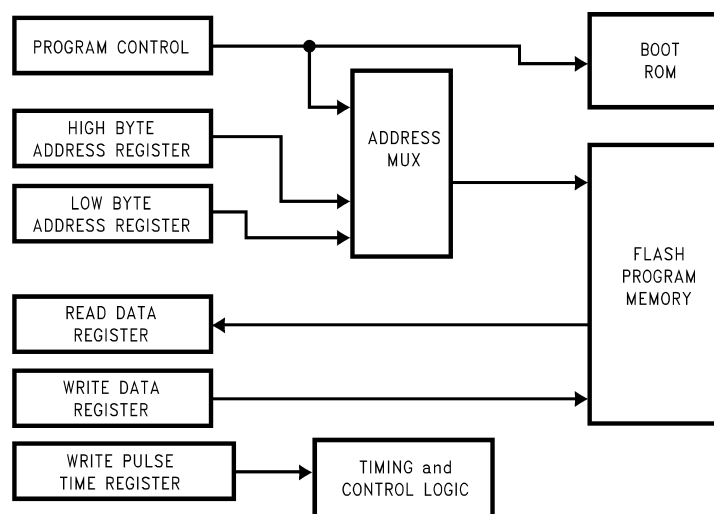

**Figure 14. Block Diagram of ISP**

As described in [OPTION REGISTER](#), there is a bit, FLEX, that controls whether the device exits RESET executing from the flash memory or the Boot ROM. The user must program the FLEX bit as appropriate for the application. In the erased state, the FLEX bit = 0 and the device will power-up executing from Boot ROM. When FLEX = 0, this assumes that either the MICROWIRE/PLUS ISP routine or external programming is being used to program the device. If using the MICROWIRE/PLUS ISP routine, the software in the boot ROM will monitor the MICROWIRE/PLUS for commands to program the flash memory. When programming the flash program memory is complete, the FLEX bit will have to be programmed to a 1 and the device will have to be reset, either by pulling external Reset to ground or by a MICROWIRE/PLUS ISP EXIT command, before execution from flash program memory will occur.

If FLEX = 1, upon exiting Reset, the device will begin executing from location 0000 in the flash program memory. The assumption, here, is that either the application is not using ISP, is using MICROWIRE/PLUS ISP by jumping to it within the application code, or is using a customized ISP routine. If a customized ISP routine is being used, then it must be programmed into the flash memory by means of the MICROWIRE/PLUS ISP or external programming as described in the preceding paragraph.

### REGISTERS

There are six registers required to support ISP: Address Register Hi byte (ISPADHI), Address Register Low byte (ISPADLO), Read Data Register (ISPRD), Write Data Register (ISPWR), Write Timing Register (PGMTIM), and the Control Register (ISPCNTRL). The ISPCNTRL Register is not available to the user.

### ISP Address Registers

The address registers (ISPADHI & ISPADLO) are used to specify the address of the byte of data being written or read. For page erase operations, the address of the beginning of the page should be loaded. For mass erase operations, 0000 must be placed into the address registers. When reading the Option register, FFFF (hex) should be placed into the address registers. Registers ISPADHI and ISPADLO are cleared to 00 on Reset. These registers can be loaded from either flash program memory or Boot ROM and must be maintained for the entire duration of the operation.

Note: The actual memory address of the Option Register is 1FFF (hex), however the MICROWIRE/PLUS ISP routines require the address FFFF (hex) to be used to read the Option Register when the Flash Memory is secured.

**Table 6. High Byte of ISP Address**

ISPADHi							
Bit 7	Bit 6	Bit 5	Bit 4	Bit 3	Bit 2	Bit 1	Bit 0
Addr 15	Addr 14	Addr 13	Addr 12	Addr 11	Addr 10	Addr 9	Addr 8

**Table 7. Low Byte of ISP Address**

ISPADLO							
Bit 7	Bit 6	Bit 5	Bit 4	Bit 3	Bit 2	Bit 1	Bit 0
Addr 7	Addr 6	Addr 5	Addr 4	Addr 3	Addr 2	Addr 1	Addr 0

### ISP Read Data Register

The Read Data Register (ISPRD) contains the value read back from a read operation. This register can be accessed from either flash program memory or Boot ROM. This register is undefined on Reset.

**Table 8. ISP Read Data Register**

ISPRD							
Bit 7	Bit 6	Bit 5	Bit 4	Bit 3	Bit 2	Bit 1	Bit 0
Bit7	Bit6	Bit5	Bit4	Bit3	Bit2	Bit1	Bit0

### ISP Write Data Register

The Write Data Register (ISPWR) contains the data to be written into the specified address. This register is undetermined on Reset. This register can be accessed from either flash program memory or Boot ROM. The Write Data register must be maintained for the entire duration of the operation.

**Table 9. ISP Write Data Register**

ISPWR							
Bit 7	Bit 6	Bit 5	Bit 4	Bit 3	Bit 2	Bit 1	Bit 0
Bit7	Bit6	Bit5	Bit4	Bit3	Bit2	Bit1	Bit0

### ISP Write Timing Register

The Write Timing Register (PGMTIM) is used to control the width of the timing pulses for write and erase operations. The value to be written into this register is dependent on the frequency of CKI and is shown in [Table 10](#). This register must be written before any write or erase operation can take place. It only needs to be loaded once, for each value of CKI frequency. This register can be loaded from either flash program memory or Boot ROM and must be maintained for the entire duration of the operation. The MICROWIRE/PLUS ISP routine that is resident in the boot ROM requires that this Register be defined prior to any access to the Flash memory. Refer to section [MICROWIRE/PLUS ISP](#) for more information on available ISP commands. On Reset, the PGMTIM register is loaded with the value that corresponds to 10 MHz frequency for CKI.

**Table 10. PGMTIM Register Format**

PGMTIM								CKI Frequency Range
Register Bit								
7	6	5	4	3	2	1	0	
0	0	0	0	0	0	0	1	25 kHz–33.3 kHz
0	0	0	0	0	0	1	0	37.5 kHz–50 kHz
0	0	0	0	0	0	1	1	50 kHz–66.67 kHz
0	0	0	0	0	1	0	0	62.5 kHz–83.3 kHz
0	0	0	0	0	1	0	1	75 kHz–100 kHz
0	0	0	0	0	1	1	1	100 kHz–133 kHz
0	0	0	0	1	0	0	0	112.5 kHz–150 kHz
0	0	0	0	1	0	1	1	150 kHz–200 kHz
0	0	0	0	1	1	1	1	200 kHz–266.67 kHz
0	0	0	1	0	0	0	1	225 kHz–300 kHz
0	0	0	1	0	1	1	1	300 kHz–400 kHz
0	0	0	1	1	1	0	1	375 kHz–500 kHz
0	0	1	0	0	1	1	1	500 kHz–666.67 kHz
0	0	1	0	1	1	1	1	600 kHz–800 kHz
0	0	1	1	1	1	1	1	800 kHz–1.067 MHz
0	1	0	0	0	1	1	1	1 MHz–1.33 MHz
0	1	0	0	1	0	0	0	1.125 MHz–1.5 MHz
0	1	0	0	1	0	1	1	1.5 MHz–2 MHz
0	1	0	0	1	1	1	1	2 MHz–2.67 MHz
0	1	0	1	0	1	0	0	2.625 MHz–3.5 MHz
0	1	0	1	1	0	1	1	3.5 MHz–4.67 MHz
0	1	1	0	0	0	1	1	4.5 MHz–6 MHz
0	1	1	0	1	1	1	1	6 MHz–8 MHz
0	1	1	1	1	0	1	1	7.5 MHz–10 MHz
R	R/W	R/W	R/W	R/W	R/W	R/W	R/W	

### MANEUVERING BACK AND FORTH BETWEEN FLASH MEMORY AND BOOT ROM

When using ISP, at some point, it will be necessary to maneuver between the flash program memory and the Boot ROM, even when using customized ISP routines. This is because it's not possible to execute from the flash program memory while it's being programmed.

Two instructions are available to perform the jumping back and forth: Jump to Boot (JSRB) and Return to Flash (RETF). The JSRB instruction is used to jump from flash memory to Boot ROM, and the RETF is used to return from the Boot ROM back to the flash program memory. See [Instruction Set](#) for specific details on the operation of these instructions.

The JSRB instruction must be used in conjunction with the Key register. This is to prevent jumping to the Boot ROM in the event of run-away software. For the JSRB instruction to actually jump to the Boot ROM, the Key bit must be set. This is done by writing the value shown in [Table 11](#) to the Key register. The Key is a 6 bit key and, if the key matches, the KEY bit will be set for 8 instruction cycles. The JSRB instruction must be executed while the KEY bit is set. If the KEY does not match, then the KEY bit will not be set and the JSRB will jump to the specified location in the flash memory. In emulation mode, if a breakpoint is encountered while the KEY is set, the counter that counts the instruction cycles will be frozen until the breakpoint condition is cleared. If an interrupt occurs while the key is set, the Key will expire before interrupt service is complete. **It is recommended that the software globally disable interrupts before setting the key and re-enable interrupts on completion of Boot ROM execution.** The Key register is a memory mapped register. Its format when writing is shown in [Table 11](#).

Table 11. KEY Register Write Format

KEY When Writing							
Bit 7	Bit 6	Bit 5	Bit 4	Bit 3	Bit 2	Bit 1	Bit 0
1	0	0	1	1	0	X	X

Bits 7–2: Key value that must be written to set the KEY bit.

Bits 1–0: Don't care.

### FORCED EXECUTION FROM BOOT ROM

When the user is developing a customized ISP routine, code lockups due to software errors may be encountered. The normal, and preferred, method to recover from these conditions is to reprogram the device with the corrected code by either an external parallel programmer or the emulation tools. As a last resort, when this equipment is not available, there is a hardware method to get out of these lockups and force execution from the Boot ROM MICROWIRE/PLUS routine. The customer will then be able to erase the Flash Memory code and start over.

The method to force this condition is to drive the G6 pin to high voltage ( $2 \times V_{CC}$ ) and activate Reset. The high voltage condition on G6 must not be applied before  $V_{CC}$  is valid and stable, and must be held for at least 3 instruction cycles longer than Reset is active. This special condition will bypass checking the state of the Flex bit in the Option Register and will start execution from location 0000 in the Boot ROM. In this state, the user can input the appropriate commands, using MICROWIRE/PLUS, to erase the flash program memory and reprogram it. If the device is subsequently reset before the Flex bit has been erased by specific Page Erase or Mass Erase ISP commands, execution will start from location 0000 in the Flash program memory. The high voltage ( $2 \times V_{CC}$ ) on G6 will not erase either the Flex or the Security bit in the Option Register. The Security bit, if set, can only be erased by a Mass Erase of the entire contents of the Flash Memory unless under the control of User ISP routines in the Application Program.

While the G6 pin is at high voltage, the Load Clock will be output onto G5, which will look like an SK clock to the MICROWIRE/PLUS routine executing in slave mode. However, when G6 is at high voltage, the G6 input will also look like a logic 1. The MICROWIRE/PLUS routine in Boot ROM monitors the G6 input, waits for it to go low, debounces it, and then enables the ISP routine. CAUTION: The Load clock on G5 could be in conflict with the user's external SK. It is up to the user to resolve this conflict, as this condition is considered a minor issue that's only encountered during software development. **The user should also be cautious of the high voltage applied to the G6 pin. This high voltage could damage other circuitry connected to the G6 pin (e.g. the parallel port of a PC).** The user may wish to disconnect other circuitry while G6 is connected to the high voltage.

$V_{CC}$  must be valid and stable before high voltage is applied to G6.

The correct sequence to be used to force execution from Boot ROM is :

1. Disconnect G6 from the source of data for MICROWIRE/PLUS ISP.
2. Apply  $V_{CC}$  to the device.
3. Pull RESET Low.
4. After  $V_{CC}$  is valid and stable, connect a voltage between  $2 \times V_{CC}$  and  $V_{CC}+7V$  to the G6 pin. Ensure that the rise time of the high voltage on G6 is slower than the minimum in the Electrical Specifications. Figure 15 shows a possible circuit diagram for implementing the  $2 \times V_{CC}$ . Be aware of the typical input current on the G6 pin when the high voltage is applied. The resistor used in the RC network, and the high voltage used, should be chosen to keep the high voltage at the G6 pin between  $2 \times V_{CC}$  and  $V_{CC}+7V$ .
5. Pull RESET High.
6. After a delay of at least three instruction cycles, remove the high voltage from G6.

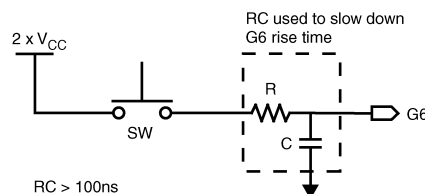

Figure 15. Circuit Diagram for Implementing the  $2 \times V_{CC}$

## RETURN TO FLASH MEMORY WITHOUT HARDWARE RESET

After programming the entire program memory, including options, it is necessary to exit the Boot ROM and return to the flash program memory for program execution. Upon receipt and completion of the EXIT command through the MICROWIRE/PLUS ISP, the ISP code will reset the part and begin execution from the flash program memory as described in the Reset section. This assumes that the FLEX bit in the Option register was programmed to 1.

### MICROWIRE/PLUS ISP

TI provides a program, which is available from our web site at [www.ti.com](http://www.ti.com), that is capable of programming a device from the parallel port of a PC. The software accepts manually input commands and is capable of downloading standard Intel HEX Format files.

Users who wish to write their own MICROWIRE/PLUS ISP host software should refer to the COP8 FLASH ISP User Manual, available from the same web site. This document includes details of command format and delays necessary between command bytes.

The MICROWIRE/PLUS ISP supports the following features and commands:

- Write a value to the ISP Write Timing Register. NOTE: This must be the first command after entering MICROWIRE/PLUS ISP mode.
- Erase the entire flash program memory (mass erase).
- Erase a page at a specified address.
- Read Option register.
- Read a byte from a specified address.
- Write a byte to a specified address.
- Read multiple bytes starting at a specified address.
- Write multiple bytes starting at a specified address.
- Exit ISP and return execution to flash program memory.

The following table lists the MICROWIRE/PLUS ISP commands and provides information on required parameters and return values.

**Table 12. MICROWIRE/PLUS ISP Commands**

Command	Function	Command Value (Hex)	Parameters	Return Data
<b>PGMTIM_SET</b>	Write Pulse Timing Register	0x3B	Value	N/A
<b>PAGE_ERASE</b>	Page Erase	0xB3	Starting Address of Page	N/A
<b>MASS_ERASE</b>	Mass Erase	0xBF	Confirmation Code	N/A (The entire Flash Memory will be erased)
<b>READ_BYTE</b>	Read Byte	0x1D	Address High, Address Low	Data Byte if Security not set. 0xFF if Security set. Option Register if address = 0xFFFF, regardless of Security
<b>BLOCKR</b>	Block Read	0xA3	Address High, Address Low, Byte Count (n) High, Byte Count (n) Low $0 \leq n \leq 32767$	n Data Bytes if Security not set. n Bytes of 0xFF if Security set.
<b>WRITE_BYTE</b>	Write Byte	0x71	Address High, Address Low, Data Byte	N/A
<b>BLOCKW</b>	Block Write	0x8F	Address High, Address Low, Byte Count ( $0 \leq n \leq 16$ ), n Data Bytes	N/A
<b>EXIT</b>	EXIT	0xD3	N/A	N/A (Device will Reset)
<b>INVALID</b>	N/A		Any other invalid command will be ignored	N/A

## USER ISP AND VIRTUAL E<sup>2</sup>

The following commands will support transferring blocks of data from RAM to flash program memory, and vice-versa. The user is expected to enforce application security in this case.

- Erase the entire flash program memory (mass erase). NOTE: Execution of this command will force the device into the MICROWIRE/PLUS ISP mode.
- Erase a page of flash memory at a specified address.
- Read a byte from a specified address.
- Write a byte to a specified address.
- Copy a block of data from RAM into flash program memory.
- Copy a block of data from program flash memory to RAM.

The following table lists the User ISP/Virtual E<sup>2</sup> commands, required parameters and return data, if applicable. The command entry point is used as an argument to the JSRB instruction. [Table 14](#) lists the Ram locations and Peripheral Registers, used for User ISP and Virtual E<sup>2</sup>, and their expected contents. Please refer to the COP8 FLASH ISP User Manual for additional information and programming examples on the use of User ISP and Virtual E<sup>2</sup>.

**Table 13. User ISP/Virtual E<sup>2</sup> Entry Points**

Command/Label	Function	Command Entry Point	Parameters	Return Data
<b>cpgerase</b>	Page Erase	0x17	Register ISPADHI is loaded by the user with the high byte of the address. Register ISPADLO is loaded by the user with the low byte of the address.	N/A (A page of memory beginning at ISPADHI, ISPADLO will be erased)
<b>cmserase</b>	Mass Erase	0x1A	Accumulator A contains the confirmation key 0x55.	N/A (The entire Flash Memory will be erased)
<b>creadbf</b>	Read Byte	0x11	Register ISPADHI is loaded by the user with the high byte of the address. Register ISPADLO is loaded by the user with the low byte of the address.	Data Byte in Register ISPRD.
<b>cblockr</b>	Block Read	0x26	Register ISPADHI is loaded by the user with the high byte of the address. Register ISPADLO is loaded by the user with the low byte of the address. X pointer contains the beginning RAM address where the result(s) will be returned. Register BYTECOUNTLO contains the number of n bytes to read (0 ≤ n ≤ 255). It is up to the user to setup the segment register.	n Data Bytes, Data will be returned beginning at a location pointed to by the RAM address in X.
<b>cwritebf</b>	Write Byte	0x14	Register ISPADHI is loaded by the user with the high byte of the address. Register ISPADLO is loaded by the user with the low byte of the address. Register ISPWR contains the Data Byte to be written.	N/A
<b>cblockw</b>	Block Write	0x23	Register ISPADHI is loaded by the user with the high byte of the address. Register ISPADLO is loaded by the user with the low byte of the address. Register BYTECOUNTLO contains the number of n bytes to write (0 ≤ n ≤ 16). The combination of the BYTECOUNTLO and the ISPADLO registers must be set such that the operation will not cross a 64 byte boundary. X pointer contains the beginning RAM address of the data to be written. It is up to the user to setup the segment register.	N/A
<b>exit</b>	EXIT	0x62	N/A	N/A (Device will Reset)

**Table 13. User ISP/Virtual E<sup>2</sup> Entry Points (continued)**

Command/Label	Function	Command Entry Point	Parameters	Return Data
uwisp	MICROWIRE/ PLUS ISP Start	0x00	N/A	N/A (Device will be in MICROWIRE/PLUS ISP Mode. Must be terminated by MICROWIRE/PLUS ISP EXIT command which will Reset the device)

**Table 14. Register and Bit Name Definitions**

Register Name	Purpose	RAM Location
ISPADHI	High byte of Flash Memory Address	0xA9
ISPADLO	Low byte of Flash Memory Address	0xA8
ISPWR	The user must store the byte to be written into this register before jumping into the write byte routine.	0xAB
ISPRD	Data will be returned to this register after the read byte routine execution.	0xAA
ISPKEY	The ISPKEY Register is required to validate the JSRB instruction and must be loaded within 6 instruction cycles before the JSRB.	0xE2
BYTECOUNTLO	Holds the count of the number of bytes to be read or written in block operations.	0xF1
PGMTIM	Write Timing Register. This register must be loaded, by the user, with the proper value before execution of any USER ISP Write or Erase operation. Refer to <a href="#">Table 10</a> for the correct value.	0xE1
Confirmation Code	The user must place this code in the accumulator before execution of a Flash Memory Mass Erase command.	A
KEY	Must be transferred to the ISPKEY register before execution of a JSRB instruction.	0x98

**RESTRICTIONS ON SOFTWARE WHEN CALLING ISP ROUTINES IN BOOT ROM**

1. The hardware will disable interrupts from occurring. The hardware will leave the GIE bit in its current state, and if set, the hardware interrupts will occur when execution is returned to Flash Memory. Subsequent interrupts, during ISP operation, from the same interrupt source will be lost. **Interrupt may occur between setting the KEY and executing the JSRB instruction. In this case, the KEY will expire before the JSRB is executed. It is, therefore, recommended that the software globally disable interrupts before setting the Key.**
2. The security feature in the MICROWIRE/PLUS ISP is ensured by software and not hardware. When executing the MICROWIRE/PLUS ISP routine, the security bit is checked prior to performing all instructions. Only the mass erase command, write PGMTIM register, and reading the Option register is permitted within the MICROWIRE/PLUS ISP routine. When the user is performing his own ISP, all commands are permitted. The entry points from the user's ISP code do not check for security. It is the burden of the user to ensure his own security. See the Security bit description in [OPTION REGISTER](#) for more details on security.
3. When using any of the ISP functions in Boot ROM, the ISP routines will service the WATCHDOG within the selected upper window. Upon return to flash memory, the WATCHDOG is serviced, the lower window is enabled, and the user can service the WATCHDOG anytime following exit from Boot ROM, but must service it within the selected upper window to avoid a WATCHDOG error.
4. Block Writes can start anywhere in the page of Flash memory, but cannot cross half page or full page boundaries.
5. **The user must ensure that a page erase or a mass erase is executed between two consecutive writes to the same location in Flash memory. Two writes to the same location without an intervening erase will produce unpredictable results including possible disturbance of unassociated locations.**

**FLASH MEMORY DURABILITY CONSIDERATIONS**

The endurance of the Flash Memory (number of possible Erase/Write cycles) is a function of the erase time and the lowest temperature at which the erasure occurs. If the device is to be used at low temperature, additional erase operations can be used to extend the erase time. The user can determine how many times to erase a page based on what endurance is desired for the application (e.g. four page erase cycles, each time a page erase is done, may be required to achieve the typical 100k Erase/Write cycles in an application which may be operating down to 0°C). Also, the customer can verify that the entire page is erased, with software, and request additional erase operations if desired.

**Table 15. Typical Flash Memory Endurance**

Erase Time	Low End of Operating Temp Range				
	-40°C	-20°C	0°C	25°C	>25°C
1 ms	60k	60k	60k	100k	100k
2 ms	60k	60k	60k	100k	100k
3 ms	60k	60k	60k	100k	100k
4 ms	60k	60k	100k	100k	100k
5 ms	70k	70k	100k	100k	100k
6 ms	80k	80k	100k	100k	100k
7 ms	90k	90k	100k	100k	100k
8 ms	100k	100k	100k	100k	100k

## Timers

The device contains a very versatile set of timers (T0, T1, T2 and T3). Timers T1, T2 and T3 and associated autoreload/capture registers power up containing random data.

### TIMER T0 (IDLE TIMER)

The device supports applications that require maintaining real time and low power with the IDLE mode. This IDLE mode support is furnished by the IDLE Timer T0, which is a 16-bit timer. The user cannot read or write to the IDLE Timer T0, which is a count down timer.

As described in [Power Saving Features](#), the clock to the IDLE Timer depends on which mode the device is in. If the device is in High Speed mode, the clock to the IDLE Timer is the instruction cycle clock (one-fifth of the CKI frequency). If the device is in Dual Clock mode or Low Speed mode, the clock to the IDLE Timer is the 32 kHz clock. For the remainder of this section, the term “selected clock” will refer to the clock selected by the Power Save mode of the device. During Dual Clock and Low Speed modes, the divide by 10 that creates the instruction cycle clock is disabled, to minimize power consumption.

In addition to its time base function, the Timer T0 supports the following functions:

- Exit out of the Idle Mode (See Idle Mode description)
- WATCHDOG logic (See WATCHDOG description)
- Start up delay out of the HALT mode
- Start up delay from BOR

[Figure 16](#) is a functional block diagram showing the structure of the IDLE Timer and its associated interrupt logic.

Bits 11 through 15 of the ITMR register can be selected for triggering the IDLE Timer interrupt. Each time the selected bit underflows (every 4k, 8k, 16k, 32k or 64k selected clocks), the IDLE Timer interrupt pending bit T0PND is set, thus generating an interrupt (if enabled), and bit 6 of the Port G data register is reset, thus causing an exit from the IDLE mode if the device is in that mode.

In order for an interrupt to be generated, the IDLE Timer interrupt enable bit T0EN must be set, and the GIE (Global Interrupt Enable) bit must also be set. The T0PND flag and T0EN bit are bits 5 and 4 of the ICNTRL register, respectively. The interrupt can be used for any purpose. Typically, it is used to perform a task upon exit from the IDLE mode. For more information on the IDLE mode, refer to section [Power Saving Features](#).

The Idle Timer period is selected by bits 0–2 of the ITMR register. Bit 3 of the ITMR Register is reserved and should not be used as a software flag. Bits 4 through 7 of the ITMR Register are used by the dual clock and are described in [Power Saving Features](#).

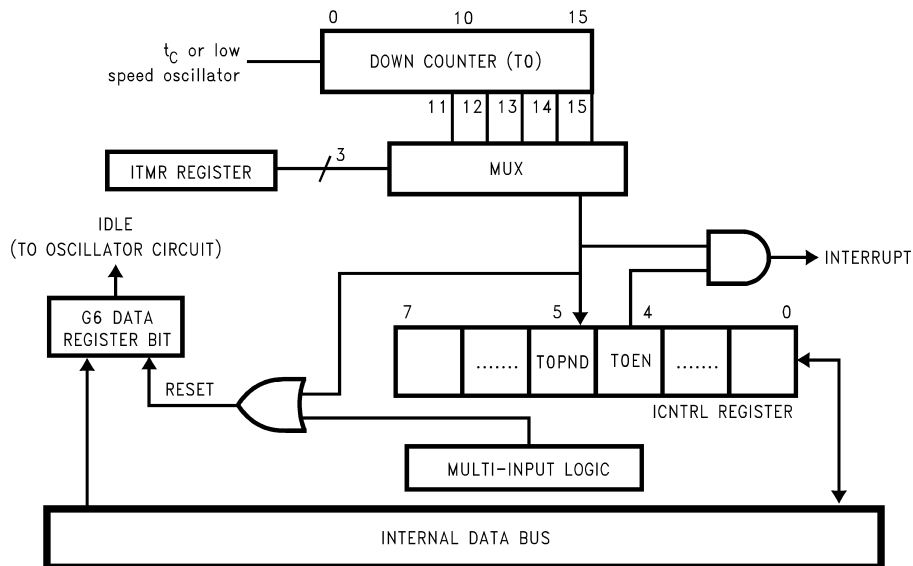

Figure 16. Functional Block Diagram for Idle Timer T0

Table 16. Idle Timer Window Length

ITSEL2	ITSEL1	ITSEL0	Idle Timer Period	
			High Speed Mode	Dual Clock or Low Speed Mode
0	0	0	4,096 inst. cycles	0.125 seconds
0	0	1	8,192 inst. cycles	0.25 seconds
0	1	0	16,384 inst. cycles	0.5 seconds
0	1	1	32,768 inst. cycles	1 second
1	0	0	65,536 inst. cycles	2 seconds
1	0	1	Reserved - Undefined	
1	1	0	Reserved - Undefined	
1	1	1	Reserved - Undefined	

The ITSEL bits of the ITMR register are cleared on Reset and the Idle Timer period is reset to 4,096 instruction cycles.

**ITMR Register**

LSON	HSON	DCEN	CCK SEL	RSVD	ITSEL2	ITSEL1	ITSEL0
Bit 7	Bit 6	Bit 5	Bit 4	Bit 3	Bit 2	Bit 1	Bit 0

**Bits 7–4:** Described in [Power Saving Features](#).

Note: Documentation for previous COP8 devices, which included the Programmable Idle Timer, recommended the user write zero to the high order bits of the ITMR Register. If existing programs are updated to use this device, writing zero to these bits will cause the device to reset (see [Power Saving Features](#)).

**RSVD:** This bit is reserved and must be set to 0.

**ITSEL2:0:** Selects the Idle Timer period as described in [Table 16, Idle Timer Window Length](#).

Any time the IDLE Timer period is changed there is the possibility of generating a spurious IDLE Timer interrupt by setting the TOPND bit. The user is advised to disable IDLE Timer interrupts prior to changing the value of the ITSEL bits of the ITMR Register and then clear the TOPND bit before attempting to synchronize operation to the IDLE Timer.

## TIMER T1, TIMER T2, AND TIMER T3

The device has a set of three powerful timer/counter blocks, T1, T2, and T3. Since T1, T2 and T3 are identical, except for the high speed operation of T2 and T3, all comments are equally applicable to any of the three timer blocks which will be referred to as Tx. Differences between the timers will be specifically noted.

The core 16-bit timer is designated T1, this section uses Tx to refer to timer T1 and all additional timers that operate in exactly the same manner as timer T1, with the exception of the high speed capability described later.

Each timer block consists of a 16-bit timer, Tx, and two supporting 16-bit autoreload/capture registers, RxA and RxB. Each timer block has two pins associated with it, TxA and TxB. The pin TxA supports I/O required by the timer block, while the pin TxB is an input to the timer block. The timer block has three operating modes: Processor Independent PWM mode, External Event Counter mode, and Input Capture mode.

The control bits TxC3, TxC2, and TxC1 allow selection of the different modes of operation.

### Timer Operating Speeds

Each of the Tx timers, except T1, have the ability to operate at either the instruction cycle frequency (low speed) or the internal clock frequency (MCLK). For 10 MHz CKI, the instruction cycle frequency is 2 MHz and the internal clock frequency is 20 MHz. This feature is controlled by the High Speed Timer Control Register, HSTCR. Its format is shown below. To place a timer, Tx, in high speed mode, set the appropriate TxHS bit to 1. For low speed operation, clear the appropriate TxHS bit to 0. This register is cleared to 00 on Reset.

The T2IDLE bit is used to allow T2 operation while the device is in Idle mode. See [TIMER T2 OPERATION IN IDLE MODE](#) for further information.

HSTCR							
Bit 7	Bit 6	Bit 5	Bit 4	Bit 3	Bit 2	Bit 1	Bit 0
T2IDLE	0	0	0	0	0	T3HS	T2HS

### Mode 1. Processor Independent PWM Mode

One of the timer's operating modes is the Processor Independent PWM mode. In this mode, the timers generate a "Processor Independent" PWM signal because once the timer is set up, no more action is required from the CPU which translates to lower software overhead and greater throughput. The user software services the timer block only when the PWM parameters require updating. This capability is provided by the fact that the timer has two separate 16-bit reload registers. One of the reload registers contains the "ON" time while the other holds the "OFF" time. By contrast, a microcontroller that has only a single reload register requires an additional software to update the reload value (alternate between the on-time/off-time).

The timer can generate the PWM output with the width and duty cycle controlled by the values stored in the reload registers. The reload registers control the countdown values and the reload values are automatically written into the timer when it counts down through 0, generating interrupt on each reload. Under software control and with minimal overhead, the PWM outputs are useful in controlling motors, triacs, the intensity of displays, and in providing inputs for data acquisition and sine wave generators.

In this mode, the timer Tx counts down at a fixed rate of  $t_c$  (T2 and T3 may be selected to operate from MCLK). Upon every underflow the timer is alternately reloaded with the contents of supporting registers, RxA and RxB. The very first underflow of the timer causes the timer to reload from the register RxA. Subsequent underflows cause the timer to be reloaded from the registers alternately beginning with the register RxB.

[Figure 17](#) shows a block diagram of the timer in PWM mode.

The underflows can be programmed to toggle the TxA output pin. The underflows can also be programmed to generate interrupts.

Underflows from the timer are alternately latched into two pending flags, TxPNDA and TxPNDB. The user must reset these pending flags under software control. Two control enable flags, TxENA and TxENB, allow the interrupts from the timer underflow to be enabled or disabled. Setting the timer enable flag TxENA will cause an interrupt when a timer underflow causes the RxA register to be reloaded into the timer. Setting the timer enable flag TxENB will cause an interrupt when a timer underflow causes the RxB register to be reloaded into the timer. Resetting the timer enable flags will disable the associated interrupts.

Either or both of the timer underflow interrupts may be enabled. This gives the user the flexibility of interrupting once per PWM period on either the rising or falling edge of the PWM output. Alternatively, the user may choose to interrupt on both edges of the PWM output.

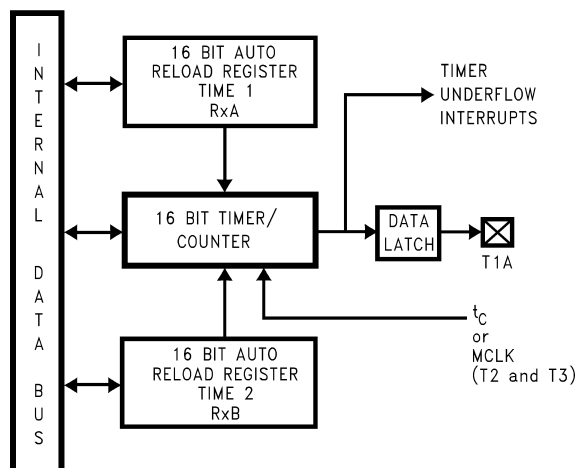

**Figure 17. Timer in PWM Mode**

If either T2 or T3 is used in High Speed PWM mode and an SBIT or RBIT instruction operates on any other bit of the PORT L Data Register, the PWM output may appear to miss a toggle and thus be inverted. If the timer causes the PWM output to toggle in the middle of an SBIT or RBIT operation on the PORTLD Register, the PWM output may be set back to its state before the output toggle by the operation of the SBIT/RBIT. This can have the effect of generating a shortened pulse (less than one instruction cycle in width) on the PWM output and inverting the PWM duty cycle.

If the PWM Timer is used in low speed mode or if the PWM output toggle is synchronous with the end of the instruction cycle, this problem is not seen. The following figure illustrates the PWM output when the failure is seen.

The user should be aware of the state of Timers T2 and T3 before any SBIT or RBIT instructions are executed which operate on the PORTLD register. If the PWM output is close to toggling, the user should delay the SBIT or RBIT instruction.

The following program sequence works to delay the operation. The user may wish to experiment with other sequences to see which best fits the application and to make sure that the time between the completion of the tests and the modification of PORTLD is not too long. The sequence can easily be modified to work with Timer T3.

```
LD    B,#TMR2HI    ;POINT B TO THE TIMER
LD    A,[B-]      ;GET THE VALUE IN THE TIMER
IFGT  A,#0        ;IF NON ZERO
JP    GOOD        ;WE HAVE TIME
WAIT: IFBIT 6,[B]  ;TEST BIT 6 OF THE TIMER
JP    GOOD        ;TIME TO GET IT DONE SAFELY
JP    WAIT        ;WAIT A WHILE
GOOD: SBIT 2,PORTLD ;GO AHEAD AND SET THE BIT
```

The above program uses specific bits of the port for explanation purposes only.

The above program uses the SBIT instruction by way of example. The RBIT instruction will have the same effect.

The above sequence will not work properly for PWM times shorter than 64 CPU Clock cycles.

The choice of TMR2LO bit 6 works, but may introduce delay at the wrong time in some applications, particularly if bit 7 is a one. The above example shows the workaround if only one timer (T2 or T3) is used in high speed PWM mode. If both Timers T2 and T3 are used in high speed PWM mode, the program becomes significantly more complicated, since the execution of the SBIT or RBIT instruction must be delayed until the PWM output of neither T2 nor T3 is likely to change during the execution of the instruction.

### Mode 2. External Event Counter Mode

This mode is quite similar to the processor independent PWM mode described above. The main difference is that the timer, Tx, is clocked by the input signal from the TxA pin after synchronization to the appropriate internal clock ( $t_c$  or MCLK). The Tx timer control bits, TxC3, TxC2 and TxC1 allow the timer to be clocked either on a positive or negative edge from the TxA pin. Underflows from the timer are latched into the TxPNDA pending flag. Setting the TxENA control flag will cause an interrupt when the timer underflows.

In this mode the input pin TxB can be used as an independent positive edge sensitive interrupt input if the TxENB control flag is set. The occurrence of a positive edge on the TxB input pin is latched into the TxPNDB flag.

Figure 18 shows a block diagram of the timer in External Event Counter mode.

Note: The PWM output is not available in this mode since the TxA pin is being used as the counter input clock.

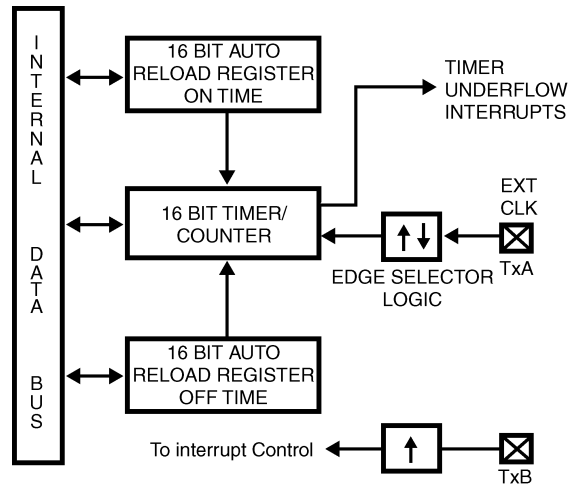

Figure 18. Timer in External Event Counter Mode

### Mode 3. Input Capture Mode

The device can precisely measure external frequencies or time external events by placing the timer block, Tx, in the input capture mode. In this mode, the reload registers serve as independent capture registers, capturing the contents of the timer when an external event occurs (transition on the timer input pin). The capture registers can be read while maintaining count, a feature that lets the user measure elapsed time and time between events. By saving the timer value when the external event occurs, the time of the external event is recorded. Most microcontrollers have a latency time because they cannot determine the timer value when the external event occurs. The capture register eliminates the latency time, thereby allowing the applications program to retrieve the timer value stored in the capture register.

In this mode, the timer Tx is constantly running at the fixed  $t_c$  or MCLK rate. The two registers, RxA and RxB, act as capture registers. Each register also acts in conjunction with a pin. The register RxA acts in conjunction with the TxA pin and the register RxB acts in conjunction with the TxB pin.

The timer value gets copied over into the register when a trigger event occurs on its corresponding pin after synchronization to the appropriate internal clock ( $t_c$  or MCLK). Control bits, TxC3, TxC2 and TxC1, allow the trigger events to be specified either as a positive or a negative edge. The trigger condition for each input pin can be specified independently.

The trigger conditions can also be programmed to generate interrupts. The occurrence of the specified trigger condition on the TxA and TxB pins will be respectively latched into the pending flags, TxPNDA and TxPNDB. The control flag TxENA allows the interrupt on TxA to be either enabled or disabled. Setting the TxENA flag enables interrupts to be generated when the selected trigger condition occurs on the TxA pin. Similarly, the flag TxENB controls the interrupts from the TxB pin.

Underflows from the timer can also be programmed to generate interrupts. Underflows are latched into the timer TxC0 pending flag (the TxC0 control bit serves as the timer underflow interrupt pending flag in the Input Capture mode). Consequently, the TxC0 control bit should be reset when entering the Input Capture mode. The timer underflow interrupt is enabled with the TxENA control flag. When a TxA interrupt occurs in the Input Capture mode, the user must check both the TxPND A and TxC0 pending flags in order to determine whether a TxA input capture or a timer underflow (or both) caused the interrupt.

Figure 19 shows a block diagram of the timer T1 in Input Capture mode. T2 and T3 are identical to T1.

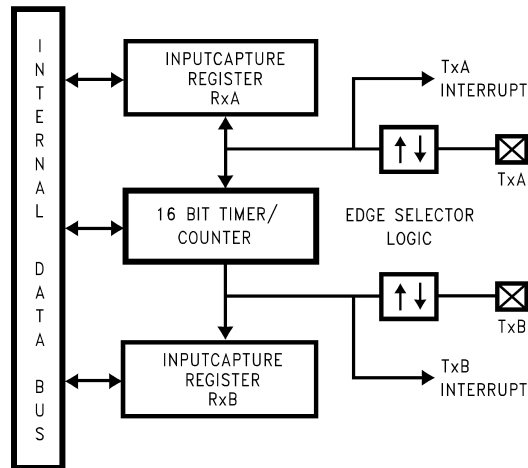

**Figure 19. Timer in Input Capture Mode**

## TIMER CONTROL FLAGS

The control bits and their functions are summarized below.

**TxC3** Timer mode control

**TxC2** Timer mode control

**TxC1** Timer mode control

**TxC0** Timer Start/Stop control in Modes 1 and 2 (Processor Independent PWM and External Event Counter), where 1 = Start, 0 = Stop

Timer Underflow Interrupt Pending Flag in Mode 3 (Input Capture)

**TxPND A** Timer Interrupt Pending Flag

**TxENA** Timer Interrupt Enable Flag

1 = Timer Interrupt Enabled

0 = Timer Interrupt Disabled

**TxPND B** Timer Interrupt Pending Flag

**TxENB** Timer Interrupt Enable Flag

1 = Timer Interrupt Enabled

0 = Timer Interrupt Disabled

The timer mode control bits (TxC3, TxC2 and TxC1) are detailed in [Table 17](#), *Timer Operating Modes*.

When the high speed timers are counting in high speed mode, directly altering the contents of the timer upper or lower registers, the PWM outputs or the reload registers is not recommended. Bit operations can be particularly problematic. Since any of these six registers or the PWM outputs can change as many as ten times in a single instruction cycle, performing an SBIT or RBIT operation with the timer running can produce unpredictable results. The recommended procedure is to stop the timer, perform any changes to the timer, the PWM outputs or reload register values, and then re-start the timer. This warning does not apply to the timer control register. Any type of read/write operation, including SBIT and RBIT may be performed on this register in any operating mode.

**Table 17. Timer Operating Modes**

Mode	TxC3	TxC2	TxC1	Description	Interrupt A Source	Interrupt B Source	Timer Counts On
1	1	0	1	PWM: TxA Toggle	Autoreload RA	Autoreload RB	t <sub>C</sub> or MCLK
	1	0	0	PWM: No TxA Toggle	Autoreload RA	Autoreload RB	t <sub>C</sub> or MCLK
2	0	0	0	External Event Counter	Timer Underflow	Pos. TxB Edge	TxA Pos. Edge
	0	0	1	External Event Counter	Timer Underflow	Pos. TxB Edge	TxA Neg. Edge
3	0	1	0	Captures:	Pos. TxA Edge	Pos. TxB Edge	t <sub>C</sub> or MCLK
				TxA Pos. Edge	or Timer		
				TxB Pos. Edge	Underflow		
	1	1	0	Captures:	Pos. TxA	Neg. TxB	t <sub>C</sub> or MCLK
				TxA Pos. Edge	Edge or Timer	Edge	
				TxB Neg. Edge	Underflow		
	0	1	1	Captures:	Neg. TxA	Pos. TxB	t <sub>C</sub> or MCLK
				TxA Neg. Edge	Edge or Timer	Edge	
				TxB Pos. Edge	Underflow		
	1	1	1	Captures:	Neg. TxA	Neg. TxB	t <sub>C</sub> or MCLK
				TxA Neg. Edge	Edge or Timer	Edge	
				TxB Neg. Edge	Underflow		

### TIMER T2 OPERATION IN IDLE MODE

Timer T2 has a special mode that allows it to be operated in IDLE mode. To use this mode, T2 must be configured as a high speed timer, by setting T2HS = 1, and, also, configured to run in the IDLE mode by setting the T2IDLE bit to 1 in the HSTCR register. Table 18 shows the modes of operation allowed for T2 during the IDLE mode. All the T2 modes are allowed except the following:

- Using the instruction cycle clock (t<sub>C</sub>)
- PWM: TxA Toggle

T2 should not be left in this special mode when entering HALT. The T2IDLE bit must be reset to 0 before entering the HALT mode to ensure that T2 remains in the same state when exiting HALT as it was prior to entering HALT.

**Table 18. Timer T2 Mode Control Bits in IDLE Mode**

Mode	TxC3	TxC2	TxC1	Description	Interrupt A Source	Interrupt B Source	Timer Counts On
1	1	0	1	Not Allowed			
	1	0	0	PWM: No TxA Toggle	Autoreload RA	Autoreload RB	MCLK
2	0	0	0	External Event Counter	Timer Underflow	Pos. TxB Edge	TxA Pos. Edge
	0	0	1	External Event Counter	Timer Underflow	Pos. TxB Edge	TxA Neg. Edge
3	0	1	0	Captures:	Pos. TxA Edge	Pos. TxB Edge	MCLK
				TxA Pos. Edge	or Timer		
				TxB Pos. Edge	Underflow		
	1	1	0	Captures:	Pos. TxA	Pos. TxB	MCLK
				TxA Pos. Edge	Edge or Timer	Edge	
				TxB Neg. Edge	Underflow		
	0	1	1	Captures:	Neg. TxA	Pos. TxB	MCLK
				TxA Neg. Edge	Edge or Timer	Edge	
				TxB Pos. Edge	Underflow		
	1	1	1	Captures:	Neg. TxA	Neg. TxB	MCLK
				TxA Neg. Edge	Edge or Timer	Edge	
				TxB Neg. Edge	Underflow		

### Timer T2 Clocking Scheme

Table 19 shows the relationship between the T2 clock, the Processor clock, and the T0 clock. Note that the T2 clock is always equal to the processor clock frequency when enabled.

**Table 19. Timer T2 Clocking Scheme**

Device Clock Mode	Idle Mode	T0 Clock	Processor Clock	T2 Clock if T2IDLE = 1	T2 Clock if T2IDLE = 0
High Speed	0	HS Clock	HS Clock	HS Clock	HS Clock
	1	HS Clock	Off	HS Clock	Off
Dual Clock	0	LS Clock	HS Clock	HS Clock	HS Clock
	1	LS Clock	Off	HS Clock	Off
Low Speed	0	LS Clock	LS Clock	LS Clock	LS Clock
	1	LS Clock	Off	LS Clock	Off

### Power Saving Features

Today, the proliferation of battery-operated applications has placed new demands on designers to drive power consumption down. Battery operated systems are not the only type of applications demanding low power. The power budget constraints are also imposed on those consumer/industrial applications where well regulated and expensive power supply costs cannot be tolerated. Such applications rely on low cost and low power supply voltage derived directly from the “mains” by using voltage rectifier and passive components. Low power is demanded even in automotive applications, due to increased vehicle electronics content. This is required to ease the burden from the car battery. Low power 8-bit microcontrollers supply the smarts to control battery-operated, consumer/industrial, and automotive applications.

The device offers system designers a variety of low-power consumption features that enable them to meet the demanding requirements of today's increasing range of low-power applications. These features include low voltage operation, low current drain, and power saving features such as HALT, IDLE, and Multi-Input Wake-Up (MIWU).

This device supports three operating modes, each of which have two power save modes of operation. The three operating modes are: High Speed, Dual Clock, and Low Speed. Within each operating mode, the two power save modes are: HALT and IDLE. In the HALT mode of operation, all microcontroller activities are stopped and power consumption is reduced to a very low level. In this device, the HALT mode is enabled and disabled by a bit in the Option register. The IDLE mode is similar to the HALT mode, except that certain sections of the device continue to operate, such as: the on-board oscillator, the IDLE Timer (Timer T0), and the Clock Monitor. This allows real time to be maintained. During power save modes of operation, all on board RAM, registers, I/O states and timers (with the exception of T0) are unaltered.

Two oscillators are used to support the three different operating modes. The high speed oscillator refers to the oscillator connected to CK1 and the low speed oscillator refers to the 32 kHz oscillator connected to pins L0 & L1. When using L0 and L1 for the low speed oscillator, the user must ensure that the L0 and L1 pins are configured for hi-Z input, L1 is not using CKX on the USART, and Multi-Input Wake-up for these pins is disabled.

A diagram of the three modes is shown in [Figure 20](#).

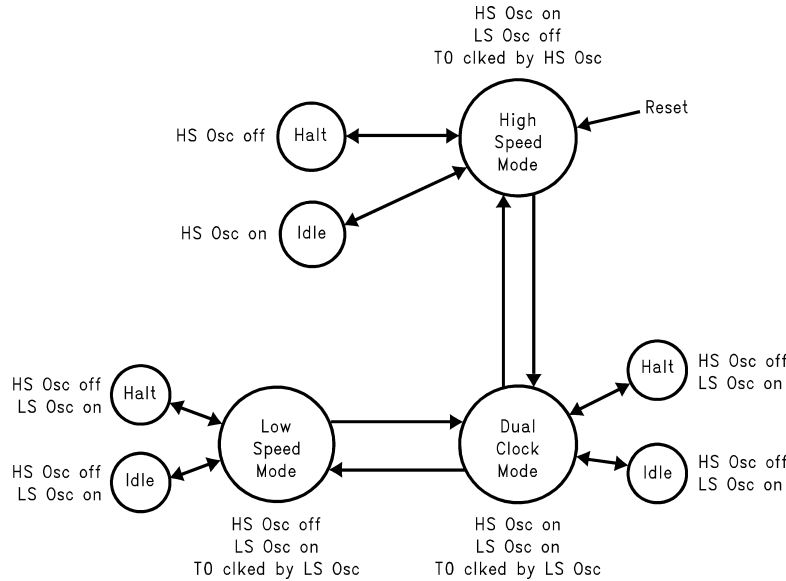

Figure 20. Diagram of Power Save Modes

**POWER SAVE MODE CONTROL REGISTER**

The ITMR control register allows for navigation between the three different modes of operation. It is also used for the Idle Timer. The register bit assignments are shown below. This register is cleared to 40 (hex) by Reset as shown below.

LSON	HSON	DCEN	CCKSEL	RSVD	ITSEL2	ITSEL1	ITSEL0
Bit 7	Bit 6	Bit 5	Bit 4	Bit 3	Bit 2	Bit 1	Bit 0

**LSON:** This bit is used to turn-on the low-speed oscillator. When LSON = 0, the low speed oscillator is off. When LSON = 1, the low speed oscillator is on. There is a startup time associated with this oscillator. See the Oscillator Circuits section.

**HSON:** This bit is used to turn-on the high speed oscillator. When HSON = 0, the high speed oscillator is off. When HSON = 1, the high speed oscillator is on. There is a startup time associated with this oscillator. See the startup time table in the Oscillator Circuits section.

**DCEN:** This bit selects the clock source for the Idle Timer. If this bit = 0, then the high speed clock is the clock source for the Idle Timer. If this bit = 1, then the low speed clock is the clock source for the Idle Timer. The low speed oscillator must be started and stabilized before setting this bit to a 1.

**CCKSEL:** This bit selects whether the high speed clock or low speed clock is gated to the microcontroller core. When this bit = 0, the Core clock will be the high speed clock. When this bit = 1, then the Core clock will be the low speed clock. Before switching this bit to either state, the appropriate clock should be turned on and stabilized.

DCEN	CCKSEL	
0	0	High Speed Mode. Core and Idle Timer Clock = High Speed
1	0	Dual Clock Mode. Core clock = High Speed; Idle Timer = Low Speed
1	1	Low Speed Mode. Core and Idle Timer Clock = Low Speed
0	1	Invalid. If this is detected, the Low Speed Mode will be forced.

**RSVD:** This bit is reserved and must be 0.

**ITSEL2–0:** These are bits used to control the Idle Timer. See [TIMER T0 \(IDLE TIMER\)](#) for the description of these bits.

[Table 20](#) lists the valid contents of the four most significant bits of the ITMR Register. States are presented in the only valid sequence. Any other value is illegal and will result in an unrecoverable loss of a clock to the CPU core. To prevent this condition, the device will automatically reset if any illegal value is detected.

**Table 20. Valid Contents of Dual Clock Control Bits**

LSON	HSON	DCEN	CCKSEL	Mode
0	1	0	0	High Speed
1	1	0	0	High Speed/Dual Clock Transition
1	1	1	0	Dual Clock
1	1	1	1	Dual Clock/Low Speed Transition
1	0	1	1	Low Speed

## OSCILLATOR STABILIZATION

Both the high speed oscillator and low speed oscillator have a startup delay associated with them. When switching between the modes, the software must ensure that the appropriate oscillator is started up and stabilized before switching to the new mode. See [Table 5, Startup Times](#) for startup times for both oscillators.

## HIGH SPEED MODE OPERATION

This mode of operation allows high speed operation for both the main Core clock and also for the IDLE Timer. This is the default mode of the device and will always be entered upon any of the Reset conditions described in the Reset section. It can also be entered from Dual Clock mode. It cannot be directly entered from the Low Speed mode without passing through the Dual Clock mode first.

To enter from the Dual Clock mode, the following sequence must be followed using two separate instructions:

1. Software clears DCEN to 0.
2. Software clears LSON to 0.

### High Speed Halt Mode

The fully static architecture of this device allows the state of the microcontroller to be frozen. This is accomplished by stopping the internal clock of the device during the HALT mode. The controller also stops the CKI pin from oscillating during the HALT mode. The processor can be forced to exit the HALT mode and resume normal operation at any time.

During normal operation, the actual power consumption depends heavily on the clock speed and operating voltage used in an application and is shown in the Electrical Specifications. In the HALT mode, the device only draws a small leakage current, plus current for the BOR feature, plus any current necessary for driving the outputs. Since total power consumption is affected by the amount of current required to drive the outputs, all I/Os should be configured to draw minimal current prior to entering the HALT mode, if possible. In order to reduce power consumption even further, the power supply ( $V_{CC}$ ) can be reduced to a very low level during the HALT mode, just high enough to ensure retention of data stored in RAM. The allowed lower voltage level ( $V_R$ ) is specified in the Electrical Specs section.

### Entering The High Speed Halt Mode

The device enters the HALT mode under software control when the Port G data register bit 7 is set to 1. All processor action stops in the middle of the next instruction cycle, and power consumption is reduced to a very low level.

### Exiting The High Speed Halt Mode

There is a choice of methods for exiting the HALT mode: a chip Reset using the  $\overline{\text{RESET}}$  pin or a Multi-Input Wake-up.

### HALT Exit Using Reset

A device Reset, which is invoked by a low-level signal on the  $\overline{\text{RESET}}$  input pin, takes the device out of the HALT mode and starts execution from address 0000H. The initialization software should determine what special action is needed, if any, upon start-up of the device from HALT. The initialization of all registers following a  $\overline{\text{RESET}}$  exit from HALT is described in the Reset section of this manual.

### HALT Exit Using Multi-Input Wake-up

The device can be brought out of the HALT mode by a transition received on one of the available Wake-up pins. The pins used and the types of transitions sensed on the Multi-input pins are software programmable. For information on programming and using the Multi-Input Wake-up feature, refer to the Multi-Input Wake-up section.

A start-up delay is required between the device wake-up and the execution of program instructions, depending on the type of chip clock. The start-up delay is mandatory, and is implemented whether or not the CLKDLY bit is set. This is because all crystal oscillators and resonators require some time to reach a stable frequency and full operating amplitude.

The IDLE Timer (Timer T0) provides a fixed delay from the time the clock is enabled to the time the program execution begins. Upon exit from the HALT mode, the IDLE Timer is enabled with a starting value of 256 and is decremented with each instruction cycle. (The instruction clock runs at one-fifth the frequency of the high speed oscillator.) An internal Schmitt trigger connected to the on-chip CKI inverter ensures that the IDLE Timer is clocked only when the oscillator has a large enough amplitude. (The Schmitt trigger is not part of the oscillator closed loop.) When the IDLE Timer underflows, the clock signals are enabled on the chip, allowing program execution to proceed. Thus, the delay is equal to 256 instruction cycles.

**Note:** To ensure accurate operation upon start-up of the device using Multi-Input Wake-up, the instruction in the application program used for entering the HALT mode should be followed by two consecutive NOP (no-operation) instructions.

### Options

This device has two options associated with the HALT mode. The first option enables the HALT mode feature, while the second option disables HALT mode operation. Selecting the disable HALT mode option will cause the microcontroller to ignore any attempts to HALT the device under software control. Note that this device can still be placed in the HALT mode by stopping the clock input to the microcontroller, if the program memory is masked ROM. See the Option section for more details on this option bit.

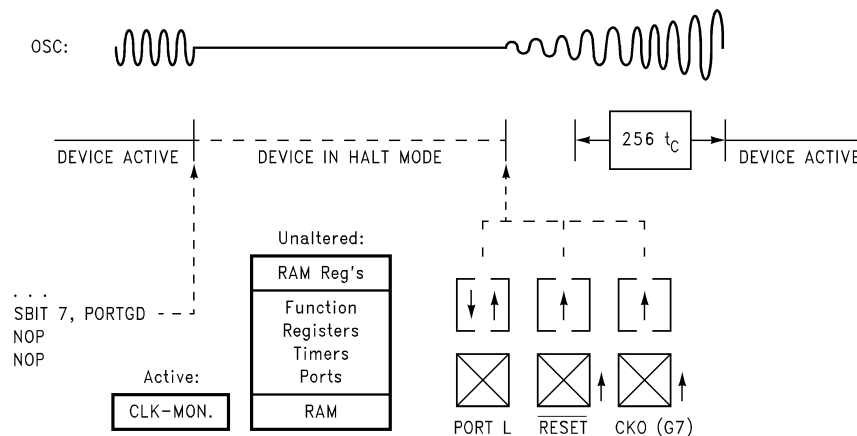

Figure 21. Wake-up from HALT

### High Speed Idle Mode

In the IDLE mode, program execution stops and power consumption is reduced to a very low level as with the HALT mode. However, the high speed oscillator, IDLE Timer (Timer T0), T2 timer (T2HS = 1, T2IDLE = 1), and Clock Monitor continue to operate, allowing real time to be maintained. The device remains idle for a selected amount of time up to 65,536 instruction cycles, or 32.768 milliseconds with a 2 MHz instruction clock frequency, and then automatically exits the IDLE mode and returns to normal program execution.

The device is placed in the IDLE mode under software control by setting the IDLE bit (bit 6 of the Port G data register).

The IDLE Timer window is selectable from one of five values, 4k, 8k, 16k, 32k or 64k instruction cycles. Selection of this value is made through the ITMR register.

The IDLE mode uses the on-chip IDLE Timer (Timer T0) to keep track of elapsed time in the IDLE state. The IDLE Timer runs continuously at the instruction clock rate, whether or not the device is in the IDLE mode. Each time the bit of the timer associated with the selected window toggles, the TOPND bit is set, an interrupt is generated (if enabled), and the device exits the IDLE mode if in that mode. If the IDLE Timer interrupt is enabled, the interrupt is serviced before execution of the main program resumes. (However, the instruction which was started as the part entered the IDLE mode is completed before the interrupt is serviced. This instruction should be a NOP which should follow the enter IDLE instruction.) The user must reset the IDLE Timer pending flag (TOPND) before entering the IDLE mode.

As with the HALT mode, this device can also be returned to normal operation with a  $\overline{\text{RESET}}$ , or with a Multi-Input Wake-up input. Upon reset the ITMR register is cleared and the ITMR register selects the 4,096 instruction cycle tap of the IDLE Timer.

The IDLE Timer cannot be started or stopped under software control, and it is not memory mapped, so it cannot be read or written by the software. Its state upon Reset is unknown. Therefore, if the device is put into the IDLE mode at an arbitrary time, it will stay in the IDLE mode for somewhere between 1 and the selected number of instruction cycles.

In order to precisely time the duration of the IDLE state, entry into the IDLE mode must be synchronized to the state of the IDLE Timer. The best way to do this is to use the IDLE Timer interrupt, which occurs on every underflow of the bit of the IDLE Timer which is associated with the selected window. Another method is to poll the state of the IDLE Timer pending bit TOPND, which is set on the same occurrence. The Idle Timer interrupt is enabled by setting bit T0EN in the ICNTRL register.

Any time the IDLE Timer window length is changed there is the possibility of generating a spurious IDLE Timer interrupt by setting the TOPND bit. The user is advised to disable IDLE Timer interrupts prior to changing the value of the ITSEL bits of the ITMR Register and then clear the TOPND bit before attempting to synchronize operation to the IDLE Timer.

**Note:** As with the HALT mode, it is necessary to program two NOP's to allow clock resynchronization upon return from the IDLE mode. The NOP's are placed either at the beginning of the IDLE Timer interrupt routine or immediately following the "enter IDLE mode" instruction.

For more information on the IDLE Timer and its associated interrupt, see the description in section [TIMER T0 \(IDLE TIMER\)](#).

## DUAL CLOCK MODE OPERATION

This mode of operation allows for high speed operation of the Core clock and low speed operation of the Idle Timer. This mode can be entered from either the High Speed mode or the Low Speed mode.

To enter from the High Speed mode, the following sequence must be followed:

1. Software sets the LSON bit to 1.
2. Software waits until the low speed oscillator has stabilized. See [Table 5](#).
3. Software sets the DCEN bit to 1.

To enter from the Low Speed mode, the following sequence must be followed:

1. Software sets the HSON bit to 1.
2. Software waits until the high speed oscillator has stabilized. See [Table 5](#), *Startup Times*.
3. Software clears the CCKSEL bit to 0.

### Dual Clock HALT Mode

The fully static architecture of this device allows the state of the microcontroller to be frozen. This is accomplished by stopping the high speed clock of the device during the HALT mode. The processor can be forced to exit the HALT mode and resume normal operation at any time. The low speed clock remains on during HALT in the Dual Clock mode.

During normal operation, the actual power consumption depends heavily on the clock speed and operating voltage used in an application and is shown in the Electrical Specifications. In the HALT mode, the device only draws a small leakage current, plus current for the BOR feature, plus the 32 kHz oscillator current, plus any current necessary for driving the outputs. Since total power consumption is affected by the amount of current required to drive the outputs, all I/Os should be configured to draw minimal current prior to entering the HALT mode, if possible.

### Entering The Dual Clock Halt Mode

The device enters the HALT mode under software control when the Port G data register bit 7 is set to 1. All processor action stops in the middle of the next instruction cycle, and power consumption is reduced to a very low level. In order to expedite exit from HALT, the low speed oscillator is left running when the device is Halted in the Dual Clock mode. However, the Idle Timer will not be clocked.

### Exiting The Dual Clock Halt Mode

When the HALT mode is entered by setting bit 7 of the Port G data register, there is a choice of methods for exiting the HALT mode: a chip Reset using the  $\overline{\text{RESET}}$  pin or a Multi-Input Wake-up. The Reset method and Multi-Input Wake-up method can be used with any clock option.

#### HALT Exit Using Reset

A device Reset, which is invoked by a low-level signal on the  $\overline{\text{RESET}}$  input pin, takes the device out of the Dual Clock mode and puts it into the High Speed mode.

#### HALT Exit Using Multi-Input Wake-up

The device can be brought out of the HALT mode by a transition received on one of the available Wake-up pins. The pins used and the types of transitions sensed on the Multi-input pins are software programmable. For information on programming and using the Multi-Input Wake-up feature, refer to [MULTI-INPUT WAKE-UP](#).

A start-up delay is required between the device wake-up and the execution of program instructions. The start-up delay is mandatory, and is implemented whether or not the CLKDLY bit is set. This is because all crystal oscillators and resonators require some time to reach a stable frequency and full operating amplitude.

If the start-up delay is used, the IDLE Timer (Timer T0) provides a fixed delay from the time the clock is enabled to the time the program execution begins. Upon exit from the HALT mode, the IDLE Timer is enabled with a starting value of 256 and is decremented with each instruction cycle using the high speed clock. (The instruction clock runs at one-fifth the frequency of the high speed oscillatory.) An internal Schmitt trigger connected to the on-chip CKI inverter ensures that the IDLE Timer is clocked only when the high speed oscillator has a large enough amplitude. (The Schmitt trigger is not part of the oscillator closed loop.) When the IDLE Timer underflows, the clock signals are enabled on the chip, allowing program execution to proceed. Thus, the delay is equal to 256 instruction cycles. After exiting HALT, the Idle Timer will return to being clocked by the low speed clock.

**Note:** To ensure accurate operation upon start-up of the device using Multi-input Wake-up, the instruction in the application program used for entering the HALT mode should be followed by two consecutive NOP (no-operation) instructions.

### Options

This device has two options associated with the HALT mode. The first option enables the HALT mode feature, while the second option disables HALT mode operation. Selecting the disable HALT mode option will cause the microcontroller to ignore any attempts to HALT the device under software control. See [OPTION REGISTER](#) for more details on this option bit.

### Dual Clock Idle Mode

In the IDLE mode, program execution stops and power consumption is reduced to a very low level as with the HALT mode. However, both oscillators, IDLE Timer (Timer T0), T2 timer (T2HS = 1, T2IDLE = 1), and Clock Monitor continue to operate, allowing real time to be maintained. The Idle Timer is clocked by the low speed clock. The device remains idle for a selected amount of time up to 1 second, and then automatically exits the IDLE mode and returns to normal program execution using the high speed clock.

The device is placed in the IDLE mode under software control by setting the IDLE bit (bit 6 of the Port G data register).

The IDLE Timer window is selectable from one of five values, 0.125 seconds, 0.25 seconds, 0.5 seconds, 2 second and 2 seconds. Selection of this value is made through the ITMR register.

The IDLE mode uses the on-chip IDLE Timer (Timer T0) to keep track of elapsed time in the IDLE state. The IDLE Timer runs continuously at the low speed clock rate, whether or not the device is in the IDLE mode. Each time the bit of the timer associated with the selected window toggles, the TOPND bit is set, an interrupt is generated (if enabled), and the device exits the IDLE mode if in that mode. If the IDLE Timer interrupt is enabled, the interrupt is serviced before execution of the main program resumes. (However, the instruction which was started as the part entered the IDLE mode is completed before the interrupt is serviced. This instruction should be a NOP which should follow the enter IDLE instruction.) The user must reset the IDLE Timer pending flag (TOPND) before entering the IDLE mode.

As with the HALT mode, this device can also be returned to normal operation with a Multi-Input Wake-up input.

The IDLE Timer cannot be started or stopped under software control, and it is not memory mapped, so it cannot be read or written by the software. Its state upon Reset is unknown. Therefore, if the device is put into the IDLE mode at an arbitrary time, it will stay in the IDLE mode for somewhere between 30  $\mu$ s and the selected time period.

In order to precisely time the duration of the IDLE state, entry into the IDLE mode must be "synchronized to the state of the IDLE Timer. The best way to do this is to use the IDLE Timer interrupt, which occurs on every underflow of the bit of the IDLE Timer which is associated with the selected window. Another method is to poll the state of the IDLE Timer pending bit TOPND, which is set on the same occurrence. The Idle Timer interrupt is enabled by setting bit T0EN in the ICNTRL register.

Any time the IDLE Timer window length is changed there is the possibility of generating a spurious IDLE Timer interrupt by setting the TOPND bit. The user is advised to disable IDLE Timer interrupts prior to changing the value of the ITSEL bits of the ITMR Register and then clear the TOPND bit before attempting to synchronize operation to the IDLE Timer.

**Note:** As with the HALT mode, it is necessary to program two NOP's to allow clock resynchronization upon return from the IDLE mode. The NOP's are placed either at the beginning of the IDLE Timer interrupt routine or immediately following the "enter IDLE mode" instruction.

For more information on the IDLE Timer and its associated interrupt, see the description in the Timers section.

## LOW SPEED MODE OPERATION

This mode of operation allows for low speed operation of the core clock and low speed operation of the Idle Timer. Because the low speed oscillator draws very little operating current, and also to expedite restarting from HALT mode, the low speed oscillator is left on at all times in this mode, including HALT mode. This is the lowest power mode of operation on the device. This mode can only be entered from the Dual Clock mode.

To enter the Low Speed mode, the following sequence must be followed using two separate instructions:

1. Software sets the CCKSEL bit to 1.
2. Software clears the HSON bit to 0.

Since the low speed oscillator is already running, there is no clock startup delay.

### **Low Speed HALT Mode**

The fully static architecture of this device allows the state of the microcontroller to be frozen. Because the low speed oscillator draws very minimal operating current, it will be left running in the low speed HALT mode. However, the IDLE Timer will not be running. This also allows for a faster exit from HALT. The processor can be forced to exit the HALT mode and resume normal operation at any time.

During normal operation, the actual power consumption depends heavily on the clock speed and operating voltage used in an application and is shown in the Electrical Specifications. In the HALT mode, the device only draws a small leakage current, plus current for the BOR feature, plus the 32 kHz oscillator current, plus any current necessary for driving the outputs. Since total power consumption is affected by the amount of current required to drive the outputs, all I/Os should be configured to draw minimal current prior to entering the HALT mode, if possible.

### Entering The Low Speed Halt Mode

The device enters the HALT mode under software control when the Port G data register bit 7 is set to 1. All processor action stops in the middle of the next instruction cycle, and power consumption is reduced to a very low level. In order to expedite exit from HALT, the low speed oscillator is left running when the device is Halted in the Low Speed mode. However, the IDLE Timer will not be clocked.

### Exiting The Low Speed Halt Mode

When the HALT mode is entered by setting bit 7 of the Port G data register, there is a choice of methods for exiting the HALT mode: a chip Reset using the  $\overline{\text{RESET}}$  pin or a Multi-Input Wake-up. The Reset method and Multi-Input Wake-up method can be used with any clock option, but the availability of the G7 input is dependent on the clock option.

#### HALT Exit Using Reset

A device Reset, which is invoked by a low-level signal on the  $\overline{\text{RESET}}$  input pin, takes the device out of the Low Speed mode and puts it into the High Speed mode.

#### HALT Exit Using Multi-Input Wake-up

The device can be brought out of the HALT mode by a transition received on one of the available Wake-up pins. The pins used and the types of transitions sensed on the Multi-input pins are software programmable. For information on programming and using the Multi-Input Wake-up feature, refer to the Multi-Input Wake-up section.

As the low speed oscillator is left running, there is no start up delay when exiting the low speed halt mode, regardless of the state of the CLKDLY bit.

**Note:** To ensure accurate operation upon start-up of the device using Multi-Input Wake-up, the instruction in the application program used for entering the HALT mode should be followed by two consecutive NOP (no-operation) instructions.

### Options

This device has two options associated with the HALT mode. The first option enables the HALT mode feature, while the second option disables HALT mode operation. Selecting the disable HALT mode option will cause the microcontroller to ignore any attempts to HALT the device under software control. See the Option section for more details on this option bit.

### Low Speed Idle Mode

In the IDLE mode, program execution stops and power consumption is reduced to a very low level as with the HALT mode. However, the low speed oscillator, IDLE Timer (Timer T0), and Clock Monitor continue to operate, allowing real time to be maintained. The device remains IDLE for a selected amount of time up to 2 seconds, and then automatically exits the IDLE mode and returns to normal program execution using the low speed clock.

The device is placed in the IDLE mode under software control by setting the IDLE bit (bit 6 of the Port G data register).

The IDLE Timer window is selectable from one of five values, 0.125 seconds, 0.25 seconds, 0.5 seconds, 1 second, and 2 seconds. Selection of this value is made through the ITMR register.

The IDLE mode uses the on-chip IDLE Timer (Timer T0) to keep track of elapsed time in the IDLE state. The IDLE Timer runs continuously at the low speed clock rate, whether or not the device is in the IDLE mode. Each time the bit of the timer associated with the selected window toggles, the TOPND bit is set, an interrupt is generated (if enabled), and the device exits the IDLE mode if in that mode. If the IDLE Timer interrupt is enabled, the interrupt is serviced before execution of the main program resumes. (However, the instruction which was started as the part entered the IDLE mode is completed before the interrupt is serviced. This instruction should be a NOP which should follow the enter IDLE instruction.) The user must reset the IDLE Timer pending flag (TOPND) before entering the IDLE mode.

As with the HALT mode, this device can also be returned to normal operation with a Multi-Input Wake-up input.

The IDLE Timer cannot be started or stopped under software control, and it is not memory mapped, so it cannot be read or written by the software. Its state upon Reset is unknown. Therefore, if the device is put into the IDLE mode at an arbitrary time, it will stay in the IDLE mode for somewhere between 30  $\mu$ s and the selected time period.

In order to precisely time the duration of the IDLE state, entry into the IDLE mode must be synchronized to the state of the IDLE Timer. The best way to do this is to use the IDLE Timer interrupt, which occurs on every underflow of the bit of the IDLE Timer which is associated with the selected window. Another method is to poll the state of the IDLE Timer pending bit TOPND, which is set on the same occurrence. The Idle Timer interrupt is enabled by setting bit T0EN in the ICNTRL register.

Any time the IDLE Timer window length is changed there is the possibility of generating a spurious IDLE Timer interrupt by setting the TOPND bit. The user is advised to disable IDLE Timer interrupts prior to changing the value of the ITSEL bits of the ITMR Register and then clear the TOPND bit before attempting to synchronize operation to the IDLE Timer.

As with the HALT mode, it is necessary to program two NOP's to allow clock resynchronization upon return from the IDLE mode. The NOP's are placed either at the beginning of the IDLE Timer interrupt routine or immediately following the "enter IDLE mode" instruction.

For more information on the IDLE Timer and its associated interrupt, see the description in [TIMER T0 \(IDLE TIMER\)](#).

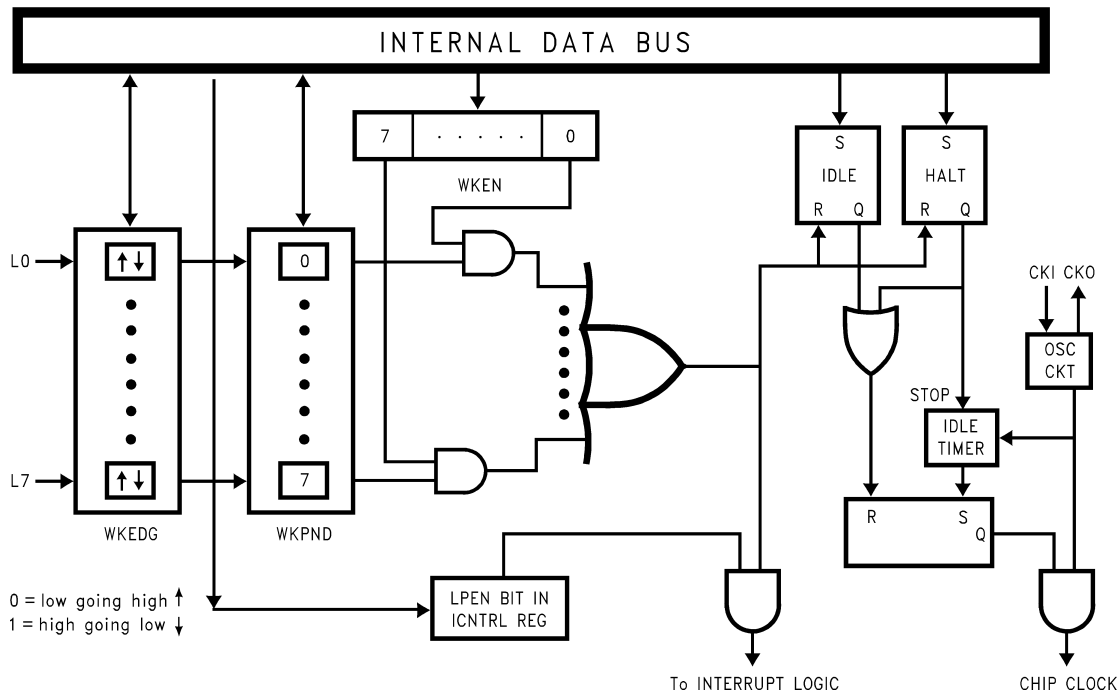

**Figure 22. Multi-Input Wake-Up Logic**

## MULTI-INPUT WAKE-UP

The Multi-Input Wake-up feature is used to return (wake-up) the device from either the HALT or IDLE modes. Alternately Multi-Input Wake-up/Interrupt feature may also be used to generate up to 8 edge selectable external interrupts.

[Figure 22](#) shows the Multi-Input Wake-up logic.

The Multi-Input Wake-up feature utilizes the L Port. The user selects which particular L port bit (or combination of L Port bits) will cause the device to exit the HALT or IDLE modes. The selection is done through the register WKEN. The register WKEN is an 8-bit read/write register, which contains a control bit for every L port bit. Setting a particular WKEN bit enables a Wake-up from the associated L port pin.

The user can select whether the trigger condition on the selected L Port pin is going to be either a positive edge (low to high transition) or a negative edge (high to low transition). This selection is made via the register WKEDG, which is an 8-bit control register with a bit assigned to each L Port pin. Setting the control bit will select the trigger condition to be a negative edge on that particular L Port pin. Resetting the bit selects the trigger condition to be a positive edge. Changing an edge select entails several steps in order to avoid a Wake-up condition as a result of the edge change. First, the associated WKEN bit should be reset, followed by the edge select change in WKEDG. Next, the associated WKPND bit should be cleared, followed by the associated WKEN bit being re-enabled.

An example may serve to clarify this procedure. Suppose we wish to change the edge select from positive (low going high) to negative (high going low) for L Port bit 5, where bit 5 has previously been enabled for an input interrupt. The program would be as follows:

```

RBIT 5, WKEN      ; Disable MIWU
SBIT 5, WKEDG    ; Change edge polarity
RBIT 5, WKPND    ; Reset pending flag
SBIT 5, WKEN     ; Enable MIWU
  
```

If the L port bits have been used as outputs and then changed to inputs with Multi-Input Wake-up/Interrupt, a safety procedure should also be followed to avoid wake-up conditions. After the selected L port bits have been changed from output to input but before the associated WKEN bits are enabled, the associated edge select bits in WKEDG should be set or reset for the desired edge selects, followed by the associated WKPND bits being cleared.

This same procedure should be used following reset, since the L port inputs are left floating as a result of reset.

The occurrence of the selected trigger condition for Multi-Input Wake-up is latched into a pending register called WKPND. The respective bits of the WKPND register will be set on the occurrence of the selected trigger edge on the corresponding Port L pin. The user has the responsibility of clearing these pending flags. Since WKPND is a pending register for the occurrence of selected wake-up conditions, the device will not enter the HALT mode if any Wake-up bit is both enabled and pending. Consequently, the user must clear the pending flags before attempting to enter the HALT mode.

WKEN and WKEDG are all read/write registers, and are cleared at reset. WKPND register contains random value after reset.

## USART

The device contains a full-duplex software programmable USART. The USART ([Figure 23](#)) consists of a transmit shift register, a receive shift register and seven addressable registers, as follows: a transmit buffer register (TBUF), a receiver buffer register (RBUF), a USART control and status register (ENU), a USART receive control and status register (ENUR), a USART interrupt and clock source register (ENUI), a prescaler select register (PSR) and baud (BAUD) register. The ENU register contains flags for transmit and receive functions; this register also determines the length of the data frame (7, 8 or 9 bits), the value of the ninth bit in transmission, and parity selection bits. The ENUR register flags framing, data overrun, parity errors and line breaks while the USART is receiving.

Other functions of the ENUR register include saving the ninth bit received in the data frame, enabling or disabling the USART's attention mode of operation and providing additional receiver/transmitter status information via RCVG and XMTG bits. The determination of an internal or external clock source is done by the ENUI register, as well as selecting the number of stop bits and enabling or disabling transmit and receive interrupts. A control flag in this register can also select the USART mode of operation: asynchronous or synchronous.

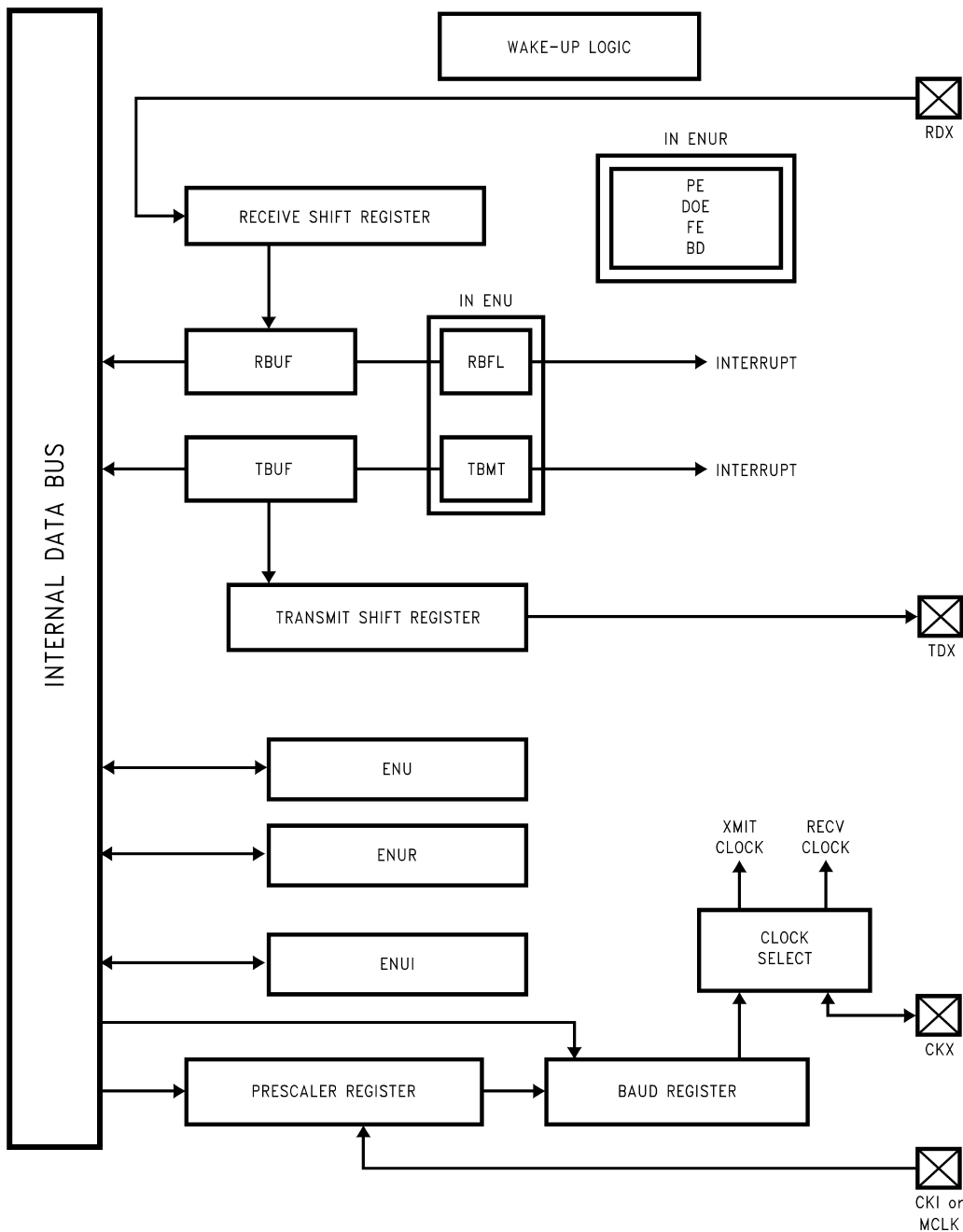

Figure 23. USART Block Diagram

**USART CONTROL AND STATUS REGISTERS**

The operation of the USART is programmed through three registers: ENU, ENUR and ENUI.

**DESCRIPTION OF USART REGISTER BITS**

**ENU—USART CONTROL AND STATUS REGISTER (Address at 0BA)**

PEN	PSEL1	XBIT9/ PSEL0	CHL1	CHL0	ERR	RBFL	TBMT
Bit 7							Bit 0

**PEN:** This bit enables/disables Parity (7- and 8-bit modes only). Read/Write, cleared on reset.

**PEN = 0** Parity disabled.

**PEN = 1** Parity enabled.

**PSEL1, PSEL0:** Parity select bits. Read/Write, cleared on reset.

**PSEL1 = 0, PSEL0 = 0** Odd Parity (if Parity enabled)

**PSEL1 = 0, PSEL1 = 1** Even Parity (if Parity enabled)

**PSEL1 = 1, PSEL0 = 0** Mark(1) (if Parity enabled)

**PSEL1 = 1, PSEL1 = 1** Space(0) (if Parity enabled)

**XBIT9/PSEL0:** Programs the ninth bit for transmission when the USART is operating with nine data bits per frame. For seven or eight data bits per frame, this bit in conjunction with PSEL1 selects parity. Read/Write, cleared on reset.

**CHL1, CHL0:** These bits select the character frame format. Parity is not included and is generated/verified by hardware. Read/Write, cleared on reset.

**CHL1 = 0, CHL0 = 0** The frame contains eight data bits.

**CHL1 = 0, CHL0 = 1** The frame contains seven data bits.

**CHL1 = 1, CHL0 = 0** The frame contains nine data bits.

**CHL1 = 1, CHL0 = 1** Loopback Mode selected. Transmitter output internally looped back to receiver input. Nine bit framing format is used.

**ERR:** This bit is a global USART error flag which gets set if any or a combination of the errors (DOE, FE, PE, BO) occur. Read only; it cannot be written by software, cleared on reset.

**RBFL:** This bit is set when the USART has received a complete character and has copied it into the RBUF register. It is automatically reset when software reads the character from RBUF. Read only; it cannot be written by software, cleared on reset.

**TBMT:** This bit is set when the USART transfers a byte of data from the TBUF register into the TSFT register for transmission. It is automatically reset when software writes into the TBUF register. Read only, bit is set to “one” on reset; it cannot be written by software.

#### **ENUR—USART RECEIVE CONTROL AND STATUS REGISTER (Address at 0BB)**

DOE	FE	PE	BD	RBIT9	ATTN	XMTG	RCVG
Bit 7							Bit 0

**DOE:** Flags a Data Overrun Error. Read only, cleared on read, cleared on reset.

**DOE = 0** Indicates no Data Overrun Error has been detected since the last time the ENUR register was read.

**DOE = 1** Indicates the occurrence of a Data Overrun Error.

**FE:** Flags a Framing Error. Read only, cleared on read, cleared on reset.

**FE = 0** Indicates no Framing Error has been detected since the last time the ENUR register was read.

**FE = 1** Indicates the occurrence of a Framing Error.

**PE:** Flags a Parity Error. Read only, cleared on read, cleared on reset.

**PE = 0** Indicates no Parity Error has been detected since the last time the ENUR register was read.

**PE = 1** Indicates the occurrence of a Parity Error.

**BD:** Flags a line break.

**BD = 0** Indicates no Line Break has been detected since the last time the ENUR register was read.

**BD = 1** Indicates the occurrence of a Line Break.

**RBIT9:** Contains the ninth data bit received when the USART is operating with nine data bits per frame. Read only, cleared on reset.

**ATTN:** ATTENTION Mode is enabled while this bit is set. This bit is cleared automatically on receiving a character with data bit nine set. Read/Write, cleared on reset.

**XMTG:** This bit is set to indicate that the USART is transmitting. It gets reset at the end of the last frame (end of last Stop bit). Read only, cleared on reset.

**RCVG:** This bit is set high whenever a framing error or a Break Detect occurs and goes low when RDX goes high. Read only, cleared on reset.

#### ENUI—USART INTERRUPT AND CLOCK SOURCE REGISTER (Address at 0BC)

STP2	BRK	ETDX	SSEL	XRCLK	XTCLK	ERI	ETI
Bit 7							Bit 0

**STP2:** This bit programs the number of Stop bits to be transmitted. Read/Write, cleared on reset.

**STP2 = 0** One Stop bit transmitted.

**STP2 = 1** Two Stop bits transmitted.

**BRK:** Holds TDX (USART Transmit Pin) low to generate a Line Break. Timing of the Line Break is under software control.

**ETDX:** TDX (USART Transmit Pin) is the alternate function assigned to Port L pin L2; it is selected by setting ETDX bit.

**SSEL:** USART mode select. Read only, cleared on reset.

**SSEL = 0** Asynchronous Mode.

**SSEL = 1** Synchronous Mode.

**XRCLK:** This bit selects the clock source for the receiver section. Read/Write, cleared on reset.

**XRCLK = 0** The clock source is selected through the PSR and BAUD registers.

**XRCLK = 1** Signal on CKX (L1) pin is used as the clock.

**XTCLK:** This bit selects the clock source for the transmitter section. Read/Write, cleared on reset.

**XTCLK = 0** The clock source is selected through the PSR and BAUD registers.

**XTCLK = 1** Signal on CKX (L1) pin is used as the clock.

**ERI:** This bit enables/disables interrupt from the receiver section. Read/Write, cleared on reset.

**ERI = 0** Interrupt from the receiver is disabled.

**ERI = 1** Interrupt from the receiver is enabled.

**ETI:** This bit enables/disables interrupt from the transmitter section. Read/Write, cleared on reset.

**ETI = 0** Interrupt from the transmitter is disabled.

**ETI = 1** Interrupt from the transmitter is enabled.

#### ASSOCIATED I/O PINS

Data is transmitted on the TDX pin and received on the RDX pin. TDX is the alternate function assigned to Port L pin L2; it is selected by setting ETDX (in the ENUI register) to one. RDX is an inherent function Port L pin L3, requiring no setup. Port L pin L2 must be configured as an output in the Port L Configuration Register in order to be used as the TDX pin.

The baud rate clock for the USART can be generated on-chip, or can be taken from an external source. Port L pin L1 (CKX) is the external clock I/O pin. The CKX pin can be either an input or an output, as determined by Port L Configuration and Data registers (Bit 1). As an input, it accepts a clock signal which may be selected to drive the transmitter and/or receiver. As an output, it presents the internal Baud Rate Generator output.

**Note:** The CKX pin is unavailable if Port L1 is used for the Low Speed Oscillator.

## USART OPERATION

The USART has two modes of operation: asynchronous mode and synchronous mode.

### ***Asynchronous Mode***

This mode is selected by resetting the SSEL (in the ENUI register) bit to zero. The input frequency to the USART is 16 times the baud rate.

The TSFT and TBUF registers double-buffer data for transmission. While TSFT is shifting out the current character on the TDX pin, the TBUF register may be loaded by software with the next byte to be transmitted. When TSFT finishes transmitting the current character the contents of TBUF are transferred to the TSFT register and the Transmit Buffer Empty Flag (TBMT in the ENU register) is set. The TBMT flag is automatically reset by the USART when software loads a new character into the TBUF register. There is also the XMTG bit which is set to indicate that the USART is transmitting. This bit gets reset at the end of the last frame (end of last Stop bit). TBUF is a read/write register.

The RSFT and RBUF registers double-buffer data being received. The USART receiver continually monitors the signal on the RDX pin for a low level to detect the beginning of a Start bit. Upon sensing this low level, it waits for half a bit time and samples again. If the RDX pin is still low, the receiver considers this to be a valid Start bit, and the remaining bits in the character frame are each sampled three times around the center of the bit time. Serial data input on the RDX pin is shifted into the RSFT register. Upon receiving the complete character, the contents of the RSFT register are copied into the RBUF register and the Received Buffer Full Flag (RBFL) is set. RBFL is automatically reset when software reads the character from the RBUF register. RBUF is a read only register. There is also the RCVG bit which is set high when a framing error or break detect occurs and goes low once RDX goes high.

### ***Synchronous Mode***

In this mode data is transferred synchronously with the clock. Data is transmitted on the rising edge and received on the falling edge of the synchronous clock.

This mode is selected by setting SSEL bit in the ENUI register. The input frequency to the USART is the same as the baud rate.

When an external clock input is selected at the CKX pin, data transmit and receive are performed synchronously with this clock through TDX/RDX pins.

If data transmit and receive are selected with the CKX pin as clock output, the device generates the synchronous clock output at the CKX pin. The internal baud rate generator is used to produce the synchronous clock. Data transmit and receive are performed synchronously with this clock.

## FRAMING FORMATS

The USART supports several serial framing formats ([Figure 24](#)). The format is selected using control bits in the ENU, ENUR and ENUI registers.

The first format (1, 1a, 1b, 1c) for data transmission (CHL0 = 1, CHL1 = 0) consists of Start bit, seven Data bits (excluding parity) and one or two Stop bits. In applications using parity, the parity bit is generated and verified by hardware.

The second format (CHL0 = 0, CHL1 = 0) consists of one Start bit, eight Data bits (excluding parity) and one or two Stop bits. Parity bit is generated and verified by hardware.

The third format for transmission (CHL0 = 0, CHL1 = 1) consists of one Start bit, nine Data bits and one or two Stop bits. This format also supports the USART "ATTENTION" feature. When operating in this format, all eight bits of TBUF and RBUF are used for data. The ninth data bit is transmitted and received using two bits in the ENU and ENUR registers, called XBIT9 and RBIT9. RBIT9 is a read only bit. Parity is not generated or verified in this mode.

The parity is enabled/disabled by PEN bit located in the ENU register. Parity is selected for 7- and 8-bit modes only. If parity is enabled (PEN = 1), the parity selection is then performed by PSEL0 and PSEL1 bits located in the ENU register.

Note that the XBIT9/PSEL0 bit located in the ENU register serves two mutually exclusive functions. This bit programs the ninth bit for transmission when the USART is operating with nine data bits per frame. There is no parity selection in this framing format. For other framing formats XBIT9 is not needed and the bit is PSEL0 used in conjunction with PSEL1 to select parity.

The frame formats for the receiver differ from the transmitter in the number of Stop bits required. The receiver only requires one Stop bit in a frame, regardless of the setting of the Stop bit selection bits in the control register. Note that an implicit assumption is made for full duplex USART operation that the framing formats are the same for the transmitter and receiver.

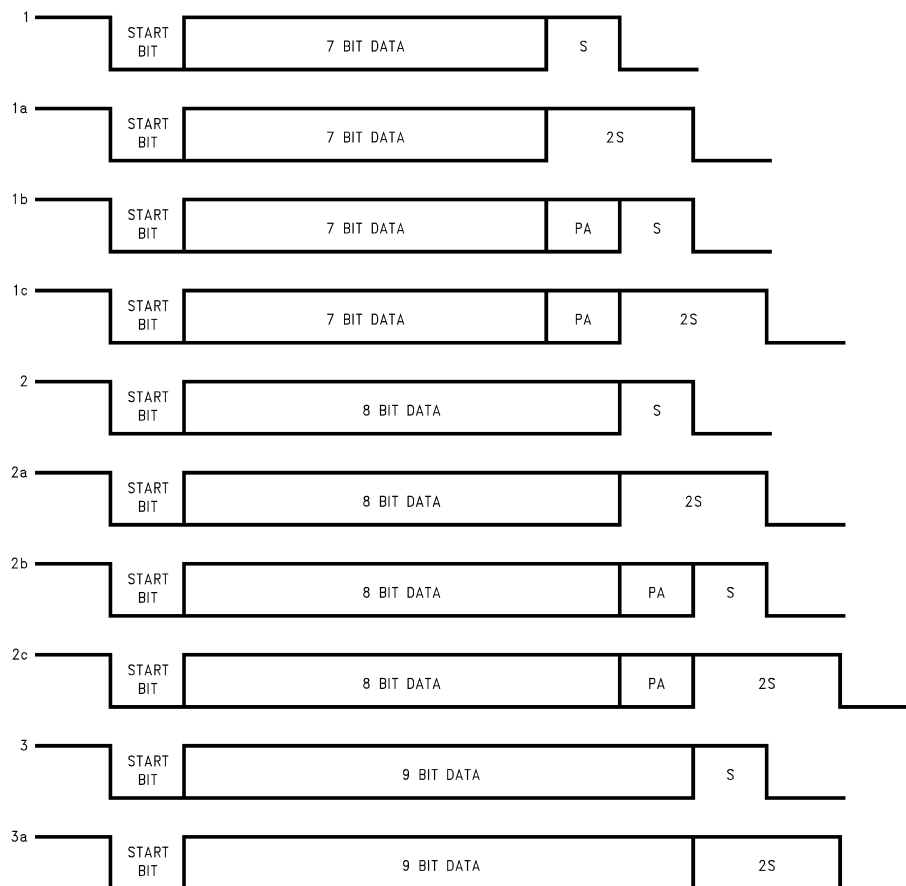

**Figure 24. Framing Formats**

## USART INTERRUPTS

The USART is capable of generating interrupts. Interrupts are generated on Receive Buffer Full and Transmit Buffer Empty. Both interrupts have individual interrupt vectors. Two bytes of program memory space are reserved for each interrupt vector. The two vectors are located at addresses 0xEC to 0xEF Hex in the program memory space. The interrupts can be individually enabled or disabled using Enable Transmit Interrupt (ETI) and Enable Receive Interrupt (ERI) bits in the ENUI register.

The interrupt from the Transmitter is set pending, and remains pending, as long as both the TBMT and ETI bits are set. To remove this interrupt, software must either clear the ETI bit or write to the TBUF register (thus clearing the TBMT bit).

The interrupt from the receiver is set pending, and remains pending, as long as both the RBFL and ERI bits are set. To remove this interrupt, software must either clear the ERI bit or read from the RBUF register (thus clearing the RBFL bit).

## BAUD CLOCK GENERATION

The clock inputs to the transmitter and receiver sections of the USART can be individually selected to come either from an external source at the CKX pin (port L, pin L1) or from a source selected in the PSR and BAUD registers. Internally, the basic baud clock is created from the MCLK through a two-stage divider chain consisting of a 1-16 (increments of 0.5) prescaler and an 11-bit binary counter (Figure 25). The divide factors are specified through two read/write registers shown in Figure 26. Note that the 11-bit Baud Rate Divisor spills over into the Prescaler Select Register (PSR). PSR is cleared upon reset.

As shown in Table 22, a Prescaler Factor of 0 corresponds to NO CLOCK. This condition is the USART power down mode where the USART clock is turned off for power saving purpose. The user must also turn the USART clock off when a different baud rate is chosen.

The correspondences between the 5-bit Prescaler Select and Prescaler factors are shown in Table 22. There are many ways to calculate the two divisor factors, but one particularly effective method would be to achieve a 1.8432 MHz frequency coming out of the first stage. The 1.8432 MHz prescaler output is then used to drive the software programmable baud rate counter to create a 16x clock for the following baud rates: 110, 134.5, 150, 300, 600, 1200, 1800, 2400, 3600, 4800, 7200, 9600, 19200 and 38400 (Table 21). Other baud rates may be created by using appropriate divisors. The 16x clock is then divided by 16 to provide the rate for the serial shift registers of the transmitter and receiver.

**Table 21. Baud Rate Divisors  
(1.8432 MHz Prescaler Output)**

Baud Rate	Baud Rate Divisor – 1 (N-1)
110 (110.03)	1046
134.5 (134.58)	855
150	767
300	383
600	191
1200	95
1800	63
2400	47
3600	31
4800	23
7200	15
9600	11
19200	5
38400	2

### NOTE

The entries in Table 21 assume a prescaler output of 1.8432 MHz. In asynchronous mode the baud rate could be as high as 625k.

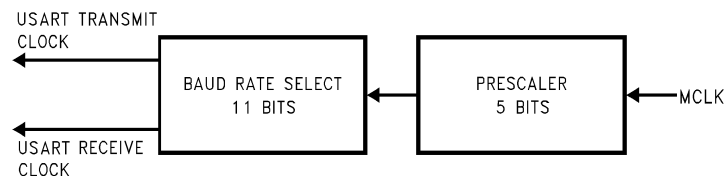

**Figure 25. USART BAUD Clock Generation**

**Table 22. Prescaler Factors**

Prescaler Select	Prescaler Factor
00000	NO CLOCK
00001	1
00010	1.5
00011	2
00100	2.5
00101	3
00110	3.5
00111	4
01000	4.5
01001	5
01010	5.5
01011	6
01100	6.5
01101	7
01110	7.5
01111	8
10000	8.5
10001	9
10010	9.5
10011	10
10100	10.5
10101	11
10110	11.5
10111	12
11000	12.5
11001	13
11010	13.5
11011	14
11100	14.5
11101	15
11110	15.5
11111	16

As an example, considering Asynchronous Mode and a crystal frequency of 4.608 MHz, the prescaler factor selected is:

$$(4.608 \times 2) / 1.8432 = 5 \quad (2)$$

The 5 entry is available in [Table 22](#). The 1.8432 MHz prescaler output is then used with proper Baud Rate Divisor ([Table 21](#)) to obtain different baud rates. For a baud rate of 19200 e.g., the entry in [Table 21](#) is 5.

$$N - 1 = 5 \quad (N - 1 \text{ is the value from } \text{Table 21})$$

$$N = 6 \quad (N \text{ is the Baud Rate Divisor})$$

$$\text{Baud Rate} = 1.8432 \text{ MHz} / (16 \times 6) = 19200$$

The divide by 16 is performed because in the asynchronous mode, the input frequency to the USART is 16 times the baud rate. The equation to calculate baud rates is given below.

The actual Baud Rate may be found from:

$$\text{BR} = (F_C \times 2) / (16 \times N \times P)$$

Where:

BR is the Baud Rate

$F_C$  is the crystal frequency

N is the Baud Rate Divisor (Table 21)

P is the Prescaler Divide Factor selected by the value in the Prescaler Select Register (Table 22)

**Note:** In the Synchronous Mode, the divisor 16 is replaced by two.

Example:

Asynchronous Mode:

Crystal Frequency = 5 MHz

Desired baud rate = 19200

Using the above equation  $N \times P$  can be calculated first.

$$N \times P = (5 \times 10^6 \times 2) / (16 \times 19200) = 32.552$$

Now 32.552 is divided by each Prescaler Factor (Table 22) to obtain a value closest to an integer. This factor happens to be 6.5 ( $P = 6.5$ ).

$$N = 32.552 / 6.5 = 5.008 \quad (N = 5)$$

The programmed value (from Table 21) should be 4 ( $N - 1$ ).

Using the above values calculated for N and P:

$$BR = (5 \times 10^6 \times 2) / (16 \times 5 \times 6.5) = 19230.769$$

$$\text{error} = (19230.769 - 19200) \times 100 / 19200 = 0.16\%$$

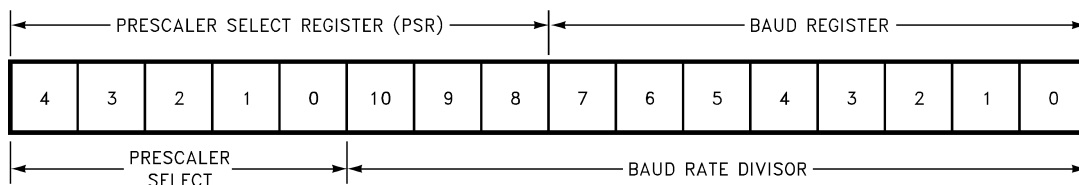

Figure 26. USART BAUD Clock Divisor Registers

## EFFECT OF HALT/IDLE

The USART logic is reinitialized when either the HALT or IDLE modes are entered. This reinitialization sets the TBMT flag and resets all read only bits in the USART control and status registers. Read/Write bits remain unchanged. The Transmit Buffer (TBUF) is not affected, but the Transmit Shift register (TSFT) bits are set to one. The receiver registers RBUF and RSFT are not affected.

The device will exit from the HALT/IDLE modes when the Start bit of a character is detected at the RDX (L3) pin. This feature is obtained by using the Multi-Input Wake-up scheme provided on the device.

Before entering the HALT or IDLE modes the user program must select the Wake-up source to be on the RDX pin. This selection is done by setting bit 3 of WKEN (Wake-up Enable) register. The Wake-up trigger condition is then selected to be high to low transition. This is done via the WKEDG register (Bit 3 is one).

If the device is halted and crystal oscillator is used, the Wake-up signal will not start the chip running immediately because of the finite start up time requirement of the crystal oscillator. The IDLE timer (T0) generates a fixed ( $256 t_C$ ) delay to ensure that the oscillator has indeed stabilized before allowing the device to execute code. The user has to consider this delay when data transfer is expected immediately after exiting the HALT mode.

## DIAGNOSTIC

Bits CHL0 and CHL1 in the ENU register provide a loopback feature for diagnostic testing of the USART. When both bits are set to one, the following occurs: The receiver input pin (RDX) is internally connected to the transmitter output pin (TDX); the output of the Transmitter Shift Register is “looped back” into the Receive Shift Register input. In this mode, data that is transmitted is immediately received. This feature allows the processor to verify the transmit and receive data paths of the USART.

Note that the framing format for this mode is the nine bit format; one Start bit, nine data bits, and one or two Stop bits. Parity is not generated or verified in this mode.

## ATTENTION MODE

The USART Receiver section supports an alternate mode of operation, referred to as ATTENTION Mode. This mode of operation is selected by the ATTN bit in the ENUR register. The data format for transmission must also be selected as having nine Data bits and either one or two Stop bits.

The ATTENTION mode of operation is intended for use in networking the device with other processors. Typically in such environments the messages consists of device addresses, indicating which of several destinations should receive them, and the actual data. This Mode supports a scheme in which addresses are flagged by having the ninth bit of the data field set to a 1. If the ninth bit is reset to a zero the byte is a Data byte.

While in ATTENTION mode, the USART monitors the communication flow, but ignores all characters until an address character is received. Upon receiving an address character, the USART signals that the character is ready by setting the RBFL flag, which in turn interrupts the processor if USART Receiver interrupts are enabled. The ATTN bit is also cleared automatically at this point, so that data characters as well as address characters are recognized. Software examines the contents of the RBUF and responds by deciding either to accept the subsequent data stream (by leaving the ATTN bit reset) or to wait until the next address character is seen (by setting the ATTN bit again).

Operation of the USART Transmitter is not affected by selection of this Mode. The value of the ninth bit to be transmitted is programmed by setting XBIT9 appropriately. The value of the ninth bit received is obtained by reading RBIT9. Since this bit is located in ENUR register where the error flags reside, a bit operation on it will reset the error flags.

## BREAK GENERATION

To generate a line break, the user software should set the BRK bit in the ENUI register. This will force the TDX pin to 0 and hold it there until the BRK bit is reset.

## A/D Converter

This device contains a 7-channel, multiplexed input, successive approximation, 10-bit Analog-to-Digital Converter with Programmable Gain Amplifier. One A/D channel is internally connected to the temperature sensor. The remaining six channels are connected to pins B2-B7 and are available external to the device. Pins AV<sub>CC</sub> and AGND are used for the A/D Converter, Temperature Sensor, Programmable Gain Amplifier, and Stand-Alone Amplifier.

## OPERATING MODES

The simplified block diagram of the A/D Converter is shown in [Figure 27](#).

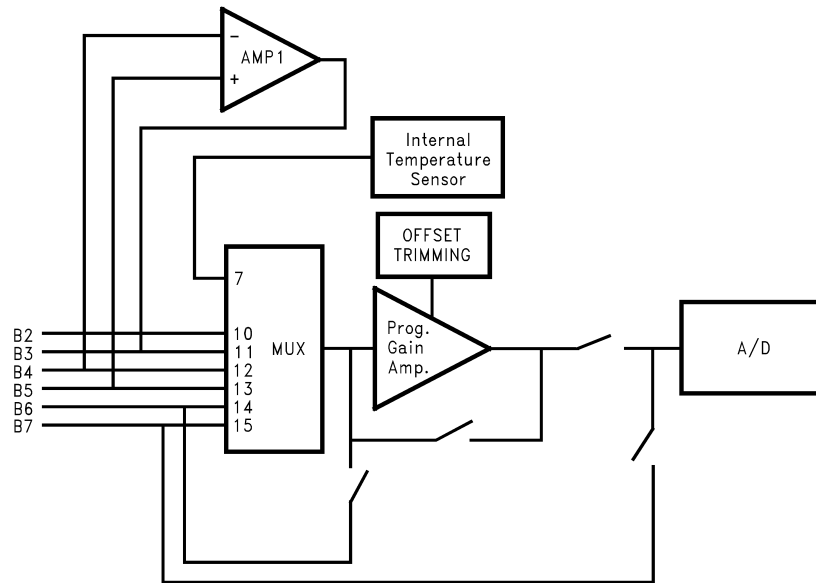

Figure 27. Simplified A/D Converter Block Diagram

The A/D Converter supports both Single Ended and Differential modes of operation. Differential mode is only supported when the programmable gain amplifier is bypassed.

Two specific analog channel selection modes are supported. These are as follows:

1. Allow any specific channel, except for the temperature sensor input, with or without the programmable gain amplifier, to be selected at one time. The A/D Converter performs the specific conversion requested and stops. When using the temperature sensor, the programmable gain amplifier is required. See the Temperature Sensor section for more details on using the temperature sensor.
2. Allow any differential channel pair to be selected at one time. The A/D Converter performs the specific differential conversion requested and stops. Differential mode is only supported when the programmable gain amplifier is bypassed.

In both Single Ended mode and Differential mode, there is the capability to connect the analog multiplexor output, with the exception of the temperature sensor input, and A/D converter input to external pins. This provides the ability to externally connect a common filter/signal conditioning circuit for the A/D Converter.

The A/D Converter is supported by six memory mapped registers: two result registers, the control register, two offset trimming registers, and the gain register. When the device is reset, the mode control register (ENAD) is cleared, the A/D is powered down and the A/D result registers have unknown data. The offset trim registers are also initialized to 40 Hex on Reset and need to be re-trimmed, if being used. The gain register is initialized to 00 on Reset.

**A/D Control Register**

The control register, ENAD contains 4 bits for channel selection, 1 bit for mode selection, 1 bit for the multiplexor output selection, 1 bit for prescaler selection, and a Busy bit. An A/D conversion is initiated by setting the ADBSY bit in the ENAD control register. The result of the conversion is available to the user in the A/D result registers, ADRSTH and ADRSTL, when ADBSY is cleared by the hardware on completion of the conversion.

Table 23. ENAD Register

Bit 7	Bit 6	Bit 5	Bit 4	Bit 3	Bit 2	Bit 1	Bit 0
Channel Select				Mode Select	Mux/Out	Prescale	Busy
ADCH3	ADCH2	ADCH1	ADCH0	ADMOD	MUX	PSC	ADBSY

### Channel Select

This 4-bit field selects one of seven channels to be the  $V_{IN+}$ . The mode selection and the mux output determine the  $V_{IN}$  input. When MUX = 0, all seven channels are available, as shown in Table 24. When MUX = 1, only 4 channels are available, as shown in Table 25.

**Table 24. A/D Converter Channel Selection when the Multiplexor Output is Disabled**

Select Bits				Mode Select ADMOD = 0 Single Ended Mode	Mode Select ADMOD = 1 Differential Mode	Mux Output Disabled
ADCH3	ADCH2	ADCH1	ADCH0	Channel No.	Channel Pairs (+, -)	MUX
0	1	1	1	Temp sensor, if enabled	Not used	0
1	0	1	0	10	10, 11 <sup>(1)</sup>	0
1	0	1	1	11	11, 10 <sup>(1)</sup>	0
1	1	0	0	12	12, 13 <sup>(1)</sup>	0
1	1	0	1	13	13, 12 <sup>(1)</sup>	0
1	1	1	0	14	14, 15 <sup>(1)</sup>	0
1	1	1	1	15	15, 14 <sup>(1)</sup>	0

(1) Only if the programmable gain amplifier is bypassed.

### Multiplexor Output Select

The MUX bit field allows the output of the A/D multiplexor (with the exception of the temperature sensor channel) and the input to the A/D to be connected directly to external pins. This allows for an external, common filter/signal conditioning circuit to be applied to all channels. The output of the external conditioning circuit can then be connected directly to the input of the Sample and Hold input on the A/D Converter. See Figure 28 for the single ended mode diagram. The Multiplexor output is connected to ADCH4 and the A/D input is connected to ADCH5. For differential mode, the differential multiplexor outputs are available and should be converted to a single ended voltage for connection to the A/D Converter Input. The programmable gain amplifier must be bypassed when using the multiplexor output feature in differential mode. See Figure 29.

The channel assignments for this mode are shown in Table 25.

When using the Mux Output feature, the delay through the internal multiplexor to the pin, plus the delay of the external filter circuit, plus the internal delay to the Sample and Hold will exceed the three clock cycles that's allowed in the conversion. This requires that whenever the MUX bit = 1, that the channel selected by ADCH3:0 bits, be enabled, even when ADBSY = 0, and gated to the mux output pin. The input path to the A/D converter should also be enabled. This allows the input channel to be selected and settled before starting a conversion. The sequence to perform conversions using the Mux Out feature is a multistep process and is listed below.

1. Select the desired channel, excluding the temperature sensor channel, and operating modes and load them into ENAD without setting ADBSY.
2. Wait the appropriate time until the analog input has settled. This will depend on the application and the response of the external circuit.
3. Select the same desired channel and operating modes used in step 1 and load them into ENAD and also set ADBSY. This will start the conversion.
4. After conversion is completed, obtain the results from the result registers.

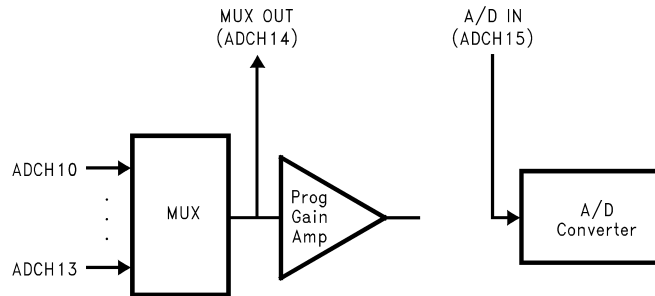

Figure 28. A/D with Single Ended Mux Output Feature Enabled

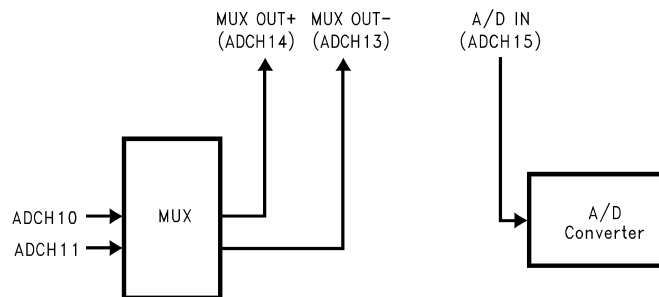

Figure 29. A/D with Differential Mux Output Feature Enabled

Table 25. A/D Converter Channel Selection when the Multiplexor Output is Enabled

Select Bits				Mode Select ADMOD = 0 Single Ended Mode	Mode Select ADMOD = 1 Differential Mode	Mux Output Enabled
ADCH3	ADCH2	ADCH1	ADCH0	Channel No.	Channel Pairs (+, -)	MUX
0	1	1	1	Temp Sensor <sup>(1)</sup>	Not used	1
1	0	0	0	Not used	Not used	1
1	0	0	1	Not used	Not used	1
1	0	1	0	10	10, 11 <sup>(2)</sup>	1
1	0	1	1	11	11, 10 <sup>(2)</sup>	1
1	1	0	0	12	Not Used	1
1	1	0	1	13	ADCH13 is Mux Output - <sup>(3)</sup> <sup>(2)</sup>	1
1	1	1	0	ADCH14 is Mux Output <sup>(3)</sup>	ADCH14 is Mux Output + <sup>(3)</sup> <sup>(2)</sup>	1
1	1	1	1	ADCH15 is A/D Input <sup>(3)</sup>	ADCH15 is A/D Input <sup>(3)</sup> <sup>(2)</sup>	1

- (1) Temperature Sensor cannot be used in this mode.
- (2) Programmable Gain Amplifier must be bypassed when MUX = 1.
- (3) These input channels are not available in this mode.

### Mode Select

This 1-bit field is used to select the mode of operation (single ended or differential) as shown in the following [Table 26](#).

**Table 26. A/D Conversion Mode Selection**

ADMOD	Mode
0	Single Ended mode. This mode is required if the temperature sensor is being selected.
1	Differential mode (programmable gain amplifier must be bypassed)

### Prescaler Select

This 1-bit field is used to select one of two prescaler clocks for the A/D Converter. The following [Table 27](#) shows the various prescaler options. Care must be taken, when selecting this bit, to not exceed the maximum frequency of the A/D converter.

**Table 27. A/D Converter Clock Prescale**

PSC	Clock Select
0	MCLK Divide by 1
1	MCLK Divide by 16

### Busy Bit

The ADBSY bit of the ENAD register is used to control starting and stopping of the A/D conversion. When ADBSY is cleared, the prescale logic is disabled and the A/D clock is turned off, drawing minimal power. Setting the ADBSY bit starts the A/D clock and initiates a conversion based on the values currently in the ENAD register. Normal completion of an A/D conversion clears the ADBSY bit and turns off the A/D Converter.

When changing the channel and gain of the programmable gain amplifier, it is necessary to wait before performing an A/D conversion. This due to the amplifier settling time. See the section on the Programmable Gain Amplifier for these settling times.

If the user wishes to restart a conversion which is already in progress, this can be accomplished only by writing a zero to the ADBSY bit to stop the current conversion and then by writing a one to ADBSY to start a new conversion. This can be done in two consecutive instructions.

All multiplexor input channels should be internally gated off when ADBSY = 0, unless MUX =1 or the programmable gain amplifier is enabled. When MUX =1 or the programmable gain amplifier is enabled, the internal path through the multiplexor to the pin and the input path for the A/D Converter should be enabled.

### A/D Result Registers

There are two result registers for the A/D converter: the high 8 bits of the result and the low 2-bits of the result. The format of these registers is shown in [Table 28](#) [Table 29](#). Both registers are read/write registers, but in normal operation, the hardware writes the value into the register when the conversion is complete and the software reads the value. Both registers are undefined upon Reset. They hold the previous value until a new conversion overwrites them. When reading ADRSTL, bits 5-0 will read as 0.

**Table 28. ADRSTH**

Bit 7	Bit 6	Bit 5	Bit 4	Bit 3	Bit 2	Bit 1	Bit 0
Bit 9	Bit 8	Bit 7	Bit 6	Bit 5	Bit 4	Bit 3	Bit 2

**Table 29. ADRSTL**

Bit 7	Bit 6	Bit 5	Bit 4	Bit 3	Bit 2	Bit 1	Bit 0
Bit 1	Bit 0	0	0	0	0	0	0

## PROGRAMMABLE GAIN AMPLIFIER

A programmable gain amplifier is located between the analog multiplexor and the input to the A/D. It supports single ended mode only. The gain of this amplifier is selected by the ADGAIN register shown in [Table 30](#). This register is also used to enable the stand-alone amplifier (AMP1) on port pins B3, B4 and B5, the internal temperature sensor, and the offset trimming configuration. Both the stand-alone amplifier and the programmable gain amplifier will draw DC current when enabled. To minimize the amount of current drawn in the HALT mode, the user should disable both amplifiers before entering HALT. This register is initialized to 00h on Reset.

**Table 30. ADGAIN**

Bit 7	Bit 6	Bit 5	Bit 4	Bit 3	Bit 2	Bit 1	Bit 0
EN-AMP1	ENTS	TRIM	Reserved		GAIN2	GAIN1	GAIN0

**ENAMP1** Enables stand-alone amplifier (AMP1) to port B. Enabled = 1. Disabled = 0.

**ENTS** Enable internal temperature sensor. Enabled = 1. Disabled = 0.

**TRIM** Configures the programmable gain amplifier into the trimming configuration by shorting its + and – inputs together. Enabled = 1. Disabled = 0. This bit should be set to 0 for normal use of the programmable gain amplifier.

**GAIN2:0** Controls the gain of the programmable gain amplifier. See [Table 31](#). When performing a conversion on the temperature sensor, a gain of 1 or 2 must be selected, depending on the operating voltage of the device. A gain of 2 can only be used for the temperature sensor if  $V_{CC} \geq 4.5V$ .

**Reserved** These bits are reserved and must be 0.

**Table 31. Gain Bit Assignments**

TRIM	GAIN2	GAIN1	GAIN0	Gain Tolerance	
0	0	0	0	Not Applicable	Amplifier disabled and bypassed.
0	0	0	1	$\pm 1$	Gain = 1
0	0	1	0	$\pm 1$	Gain = 2
0	0	1	1	$\pm 1$	Gain = 5
0	1	0	0	$\pm 2$	Gain = 10
0	1	0	1	$\pm 2$	Gain = 20
0	1	1	0	$\pm 2$	Gain = 49
0	1	1	1	$\pm 2$	Gain = 98
1	X	X	X	N/A	Gain = open loop for trimming. Amplifier is enabled.

### Programmable Gain Amplifier Settling Time

When changing channels or the gain, it's necessary to give the programmable gain amplifier time to settle before performing an A/D conversion. This is because the input from the previous channel could have the amplifier output near one power supply rail and the newly selected channel or gain may need to drive the output to the other power supply rail. The amount of settling time is based on the gain of the amplifier. See [Table 32](#). It is recommended that the user wait 7.6 time constants ( $\tau$ ) before performing an A/D conversion. This should give the amplifier time to settle within 0.5 LSB of the A/D converter. This settling time needs to be taken into effect if either the gain is changed or if the channel is changed. Since these values are in different registers, they can't be changed simultaneously and must be changed individually. The settling time starts whenever either one is changed, but it's not cumulative. The user should wait the amount of settling time specified after the latter of the channel or gain change.

**Table 32. Programmable Gain Amplifier Settling Times**

GAIN	Time Constant ( $\tau$ )	Settling Time (7.6 * $\tau$ )
1	Slew Rate Limited	Slew Rate Limited
2	Under-Damp Response	9 $\mu$ s
5	Under-Damp Response	6 $\mu$ s

**Table 32. Programmable Gain Amplifier Settling Times (continued)**

GAIN	Time Constant ( $\tau$ )	Settling Time ( $7.6 * \tau$ )
10	0.7 $\mu$ s	5 $\mu$ s
20	2 $\mu$ s	16 $\mu$ s
49	3.2 $\mu$ s	25 $\mu$ s
98	5.8 $\mu$ s	45 $\mu$ s
Open Loop	N/A	1050 $\mu$ s

**Programmable Gain Amplifier Offset Calibration**

The programmable gain amplifier has an offset that could be as high as  $\pm 7$  mV. When using this amplifier, a user may want to nullify this offset to obtain more accurate measurements with the A/D converter. Since this amplifier has both an N channel and P channel pair on its input stage, it's necessary to adjust both pairs. This is done with the use of two volatile registers, AMPTRMN and AMPTRMP, and some on-chip circuits. The two trim registers will allow for trimming out the offset in 0.5 mV steps in either direction. Once the amplifier is trimmed, the trim values are stored in AMPTRMN and AMPTRMP. Retrimming is necessary after any type of Reset. These two registers are initialized to 040 (hex) on a Reset.

**Table 33. AMPTRMN**

Bit 7	Bit 6	Bit 5	Bit 4	Bit 3	Bit 2	Bit 1	Bit 0
CALN	ATRMN6	ATRMN5	ATRMN4	ATRMN3	ATRMN2	ATRMN1	ATRMN0

**CALN** Enables the internal reference, VREFN, for trimming the N channel pair. Enabled = 1, Disabled = 0. This bit, when = 1, also disables the analog multiplexor. To perform the trimming algorithm, the TRIM bit must also = 1.

**ATRMN6:0** Trim bits used for actual trimming. It uses a signed magnitude method. ATRMN6 is the sign bit. When ATRMN6 = 1, it compensates for positive offset. When ATRMN6 = 0, it compensates for negative offset. ATRMN5:0 are the magnitude of the trim with 000000 = no trim value and 111111 = highest trim value.

**Table 34. AMPTRMP**

Bit 7	Bit 6	Bit 5	Bit 4	Bit 3	Bit 2	Bit 1	Bit 0
CALP	ATRMP6	ATRMP5	ATRMP4	ATRMP3	ATRMP2	ATRMP1	ATRMP0

**CALP** Enables the internal reference, VREFP, for trimming the P channel pair. Enabled = 1, Disabled = 0. This bit, when = 1, also disables the analog multiplexor. To perform the trimming algorithm, the TRIM bit must also = 1.

**ATRMP6:0** Trim bits used for actual trimming. It uses a signed magnitude method. ATRMP6 is the sign bit. When ATRMP6 = 1, it compensates for positive offset. When ATRMP6 = 0, it compensates for negative offset. ATRMP5:0 are the magnitude of the trim with 000000 = no trim value and 111111 = highest trim value.

**Trimming the Offset on the Programmable Gain Amplifier**

Setting the TRIM bit puts the programmable gain amplifier into a special configuration used for trimming the offset, which is shown in [Figure 30](#). This configuration enables the amplifier and puts it into open loop gain. By selecting the reference voltages, VREFN and VREFP, one at a time, the offset can be calibrated using the A/D converter. The calibration routine uses software to perform a successive approximation algorithm and is indicated below. After the trim algorithm is complete, the trim values are stored in the AMPTRMN and AMPTRMP registers and should remain, unchanged, until the algorithm is executed again. The trim values stored in AMPTRMN and AMPTRMP values are lost if any type of reset is generated. Therefore, it's necessary to retrim after any type of Reset. A method to minimize retrimming would be to store the initial trim values into the virtual EEPROM memory in addition to AMPTRMN and AMPTRMP. Then, whenever necessary, the trim values could be retrieved from virtual EEPROM, avoiding execution of the trim algorithm upon a Reset.

The amplifier offset can drift slightly as the temperature changes. For example, over the entire temperature range of  $-40^{\circ}\text{C}$  to  $+125^{\circ}\text{C}$ , the drift could be typically 2 mV. If the user application is in a constantly changing temperature, and this offset drift is a problem, it is recommended that the amplifier be retrimmed periodically, or before critical measurements. The on-chip temperature sensor could also be used to measure temperature variations and determine whether retrimming of the offset is necessary.

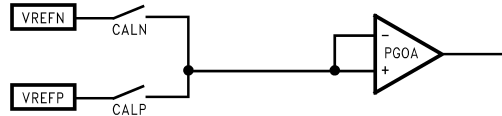

**Figure 30. Offset Trim Configuration when TRIM = 1**

The procedure to trim both the N channel pair and P channel pair are listed below. Steps 1–14 trim the N channel pair and steps 15–30 trim the P channel pair.

1. Set the TRIM bit = 1 in the ADGAIN register to configure the amplifier.
2. Load C0h into the AMPTRMN register to select VREFN and the no-trim value.
3. Wait 1.05 ms for the amplifier to settle.
4. Load 01h into ENAD to perform an A/D Conversion.
5. Store the result registers.
6. If the three most significant bits of the result are all ones, go to step 8.
  - Else, if the three most significant bits are all zeros, go to step 7.
  - Else, goto step 15.
7. Set ATRMN6 = 0
8. First time through loop, set ATRMN5 = 1
  - Second time through loop, set ATRMN4 = 1
  - Third time through loop, set ATRMN3 = 1
  - Fourth time through loop, set ATRMN2 = 1
  - Fifth time through loop, set ATRMN1 = 1
  - Sixth time through loop, set ATRMN0 = 1
  - Seventh time through loop, go to step 15.
9. Wait 1.05 ms for the amplifier to settle.
10. Load 01h into ENAD to perform an A/D Conversion.
11. Store the result registers.
12. If the three most significant bits of the result are all ones and ATRMN6 = 1, go to step 8.
  - Else, if the three most significant bits are all zeros and ATRMN6 = 1, go to step 13.
  - Else, if the three most significant bits are all ones and ATRMN6 = 0, go to step 13.
  - Else, if the three most significant bits are all zeros and ATRMN6 = 0, go to step 8.
  - Go to step 15.
13. First time through loop, set ATRMP5 = 0
  - Second time through loop, set ATRMP4 = 0
  - Third time through loop, set ATRMP3 = 0
  - Fourth time through loop, set ATRMP2 = 0
  - Fifth time through loop, set ATRMP1 = 0
  - Sixth time through loop, set ATRMP0 = 0
14. Go to step 8.
15. Reset CALN bit = 0, but leave ATRMN6 : 0 unchanged.
16. Load C0h into the AMPTRMP register to select VREFP and the no-trim value.
17. Wait 1.05 ms for the amplifier to settle.
18. Load 01h into ENAD to perform an A/D Conversion.
19. Store the result registers.

20. If the three most significant bits of the result are all ones, go to step 22.
  - Else, if the three most significant bits are all zeros, go to step 21.
  - Else, goto step 29.
21. Set ATRMN6 = 0
22. First time through loop, set ATRMN5=1
  - Second time through loop, set ATRMN4=1
  - Third time through loop, set ATRMN3=1
  - Fourth time through loop, set ATRMN2=1
  - Fifth time through loop, set ATRMN1=1
  - Sixth time through loop, set ATRMN0=1
  - Seventh time through loop, go to step 29.
23. Wait 1.05 ms for the amplifier to settle.
24. Load 01h into ENAD to perform an A/D Conversion.
25. Store the result registers.
26. If the three most significant bits of the result are all ones and ATRMN6 = 1, go to step 22.
  - Else, if the three most significant bits are all zeros and ATRMN6 = 1, go to step 27.
  - Else, if the three most significant bits are all ones and ATRMN6 = 0, go to step 27.
  - Else, if the three most significant bits are all zeros and ATRMN6 = 0, go to step 22.
  - Go to step 29.
27. First time through loop, set ATRMP5 = 0
  - Second time through loop, set ATRMP4 = 0
  - Third time through loop, set ATRMP3 = 0
  - Fourth time through loop, set ATRMP4 = 0
  - Fifth time through loop, set ATRMP1 = 0
  - Sixth time through loop, set ATRMP0 = 0
28. Go to step 22.
29. Reset CALP bit = 0, but leave ATRMP6:0 unchanged.
30. Reset the TRIM bit to 0.

## A/D OPERATION

The A/D conversion is completed within fifteen A/D converter clocks. The A/D Converter interface works as follows. Setting the ADBSY bit in the A/D control register ENAD initiates an A/D conversion. The conversion sequence starts at the beginning of the write to ENAD operation which sets ADBSY, thus powering up the A/D. At the first edge of the Converter clock following the write operation, the sample signal turns on for three clock cycles. At the end of the conversion, the internal conversion complete signal will clear the ADBSY bit and power down the A/D. The A/D 10-bit result is immediately loaded into the A/D result registers (ADRSTH and ADRSTL) upon completion during TCSTART. This prevents transient data (resulting from the A/D writing a new result over an old one) being read from ADRSLT.

Inadvertent changes to the ENAD register during conversion are prevented by the control logic of the A/D. Any attempt to write any bit of the ENAD Register except ADBSY, while ADBSY is a one, is ignored. ADBSY must be cleared either by completion of an A/D conversion or by the user before the prescaler, conversion mode or channel select values can be changed. After stopping the current conversion, the user can load different values for the prescaler, conversion mode or channel select and start a new conversion in one instruction.

### Prescaler

The A/D Converter (A/D) contains a prescaler option that allows two different clock selections. The A/D clock frequency is equal to MCLK divided by the prescaler value. Note that the prescaler value must be chosen such that the A/D clock falls within the specified range. The maximum A/D frequency is 1.67 MHz. This equates to a 600 ns A/D clock cycle.

The A/D Converter takes 15 A/D clock cycles to complete a conversion. Thus the minimum A/D conversion time is 12  $\mu$ s when a prescaler of 16 has been selected with MCLK = 20 MHz. The 15 A/D clock cycles needed for conversion consist of 3 cycles for sampling, 1 cycle for auto-zeroing the comparator, 10 cycles for converting, 1 cycle for loading the result into the result registers and for stopping and re-initializing. The ADBSY flag provides an A/D clock inhibit function, which saves power by powering down the A/D when it is not in use.

**NOTE**

The A/D Converter is also powered down when the device is in either the HALT or IDLE modes. If the A/D is running when the device enters the HALT or IDLE modes, the A/D powers down and then restarts the conversion from the beginning with a corrupted sampled voltage (and thus an invalid result) when the device comes out of the HALT or IDLE modes.

**NOTE**

If a Breakpoint is issued during an A/D conversion, the conversion will be completed.

**ANALOG INPUT AND SOURCE RESISTANCE CONSIDERATIONS**

Figure 31 shows the A/D pin model in single ended mode. The differential mode has a similar A/D pin model. The leads to the analog inputs should be kept as short as possible. Both noise and digital clock coupling to an A/D input can cause conversion errors. The clock lead should be kept away from the analog input line to reduce coupling.

Source impedances greater than 3 k $\Omega$  on the analog input lines will adversely affect the internal RC charging time during input sampling. As shown in Figure 31, the analog switch to the Sample & Hold capacitor is closed only during the 3 A/D cycle sample time. Large source impedances on the analog inputs may result in the Sample & Hold capacitor not being charged to the correct voltage levels, causing scale errors.

If large source resistance is necessary, the recommended solution is to slow down the A/D clock speed in proportion to the source resistance. The A/D Converter may be operated at the maximum speed for R<sub>S</sub> less than 3 k $\Omega$ . For R<sub>S</sub> greater than 3 k $\Omega$ , A/D clock speed needs to be reduced. For example, with R<sub>S</sub> = 6 k $\Omega$ , the A/D Converter may be operated at half the maximum speed. A/D Converter clock speed may be slowed down by either increasing the A/D prescaler divide-by or decreasing the CKI clock frequency. The A/D minimum clock speed is 64 kHz.

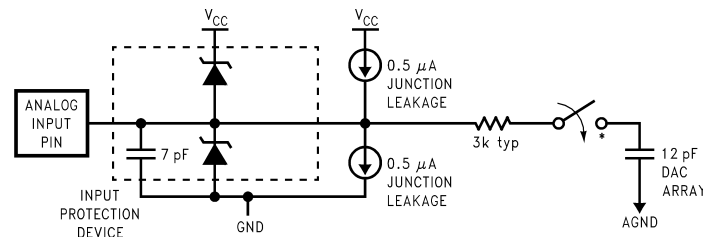

\*The analog switch is closed only during the sample time.

**Figure 31. A/D Pin Model (Single Ended Mode)**

**Temperature Sensor**

**GENERAL DESCRIPTION**

The Temperature Sensor on this device operates over a -40°C to +125°C temperature range and produces an output voltage proportional to the device temperature. The transfer function is approximately linear. Refer to the A/D Converter section to see how the Temperature Sensor is integrated with the Programmable Gain Amplifier and A/D Converter.

The equation for V<sub>OUT</sub> vs. temperature is:

$$V_{OUT} = [(-8.0 \text{ mV}/^{\circ}\text{C}) \times T] + 1.65\text{V} \tag{3}$$

where T is the temperature in °C.

The user can achieve greater temperature sensor accuracy by performing a two temperature calibration to compensate for device-to-device variations in slope and base value for  $V_{OUT}$ .

## OPERATION

The Temperature Sensor is used in conjunction with the on-chip Programmable Gain Amplifier and A/D converter to read the Temperature Sensor output voltage. The Programmable Gain Amplifier must be used and the gain can be set at either 1 or 2, depending on the operating voltage of the device. To use a gain of 2,  $V_{CC}$  should be greater than 4.5V. The output voltage given in the above equation is for a gain of 1. The Temperature Sensor is connected to channel 7 on the A/D Converter multiplexor. See the A/D Converter section for more details on using the ENAD and ADGAIN registers.

The Temperature Sensor is enabled by setting the ENTS bits in the ADGAIN register to a 1. The circuit will draw power when it's enabled. When disabled, the current drawn is extremely low. When using the HALT mode of the device, the Temperature Sensor will draw current unless it is disabled by software. Therefore, for minimal current in HALT mode, the Temperature Sensor should be disabled prior to entering HALT. A Reset will disable the Temperature Sensor.

### ***Procedure for Reading the Temperature Sensor Voltage***

The following steps should be followed for measuring the temperature sensor voltage:

1. Enable the Temperature Sensor by setting the ENTS bit in the ADGAIN register to 1. The Programmable Gain Amplifier gain should also be selected to be either 1 or 2.
2. Wait 350  $\mu$ s for the temperature sensor to stabilize. This is only required after ENTS bit is changed from 0 to 1.
3. Load the ENAD register with the channel number for the temperature sensor, and the desired prescale value. The ADMOD, MUX, and ADBSY bits should be 0.
4. Wait for the Programmable Gain Amplifier to stabilize with the voltage for the newly selected channel.
5. Set the ADBSY bit in the ENAD register. The other bits in the ENAD register should be the same as in step 3.
6. Wait for the ADBSY bit to go to 0 and then read the output of the A/D Converter result registers, ADRSTH and ADRSTL.
7. Subsequent readings of the temperature sensor can be done by repeating steps 5 and 6, as long as the channel number in ENAD has not changed from that of the temperature sensor. If the channel number has been changed to measure other channels, in between two successive temperature sensor readings, then steps 1–6 should be followed.

## Stand-Alone Amplifier

A stand-alone Amplifier, AMP1, is provided on Port B. It supports rail-to-rail inputs and outputs, and operates over the entire  $V_{CC}$  and temperature range. This amplifier is in addition to the programmable gain amplifier in the A/D Converter. It is an alternate function on Port B.

It is enabled/disabled by the ENAMP1 bit in the ADGAIN register described in the A/D Converter section. The normal port B3–B5 pins should be configured in their high Z state when using AMP1. It is disabled after Reset. The circuit will only draw current when it's enabled. When disabled, the current drawn is extremely low.

When using the HALT mode of the device, AMP1 will draw current unless it is disabled by software. Therefore, for minimal current in HALT mode, AMP1 should be disabled prior to entering HALT.

The electrical parameters of AMP1 are shown in the Electrical Characteristics section.

## BLOCK DIAGRAM

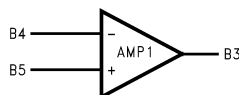

**Figure 32. Amplifier1 Block Diagram**

## Interrupts

### INTRODUCTION

The device supports fourteen vectored interrupts. Interrupt sources include Timer 1, Timer 2, Timer 3, Timer T0, Port L Wake-up, Software Trap, MICROWIRE/PLUS, USART and External Input.

All interrupts force a branch to location 00FF Hex in program memory. The VIS instruction may be used to vector to the appropriate service routine from location 00FF Hex.

The Software trap has the highest priority while the default VIS has the lowest priority.

Each of the 13 maskable inputs has a fixed arbitration ranking and vector.

Figure 33 shows the Interrupt block diagram.

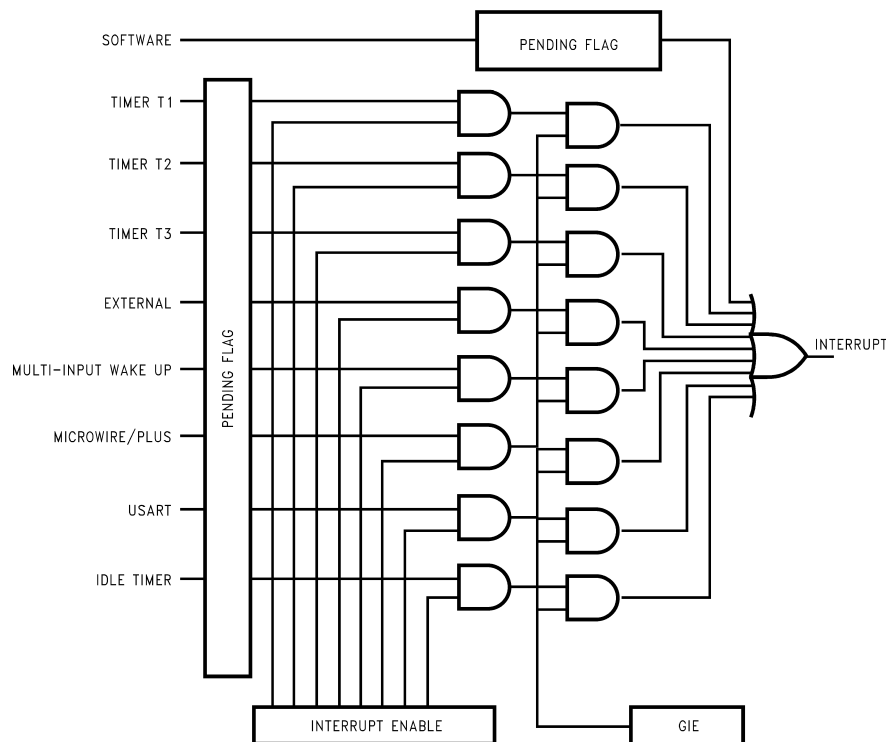

Figure 33. Interrupt Block Diagram

### MASKABLE INTERRUPTS

All interrupts other than the Software Trap are maskable. Each maskable interrupt has an associated enable bit and pending flag bit. The pending bit is set to 1 when the interrupt condition occurs. The state of the interrupt enable bit, combined with the GIE bit determines whether an active pending flag actually triggers an interrupt. All of the maskable interrupt pending and enable bits are contained in mapped control registers, and thus can be controlled by the software.

A maskable interrupt condition triggers an interrupt under the following conditions:

1. The enable bit associated with that interrupt is set.
2. The GIE bit is set.
3. The device is not processing a non-maskable interrupt. (If a non-maskable interrupt is being serviced, a maskable interrupt must wait until that service routine is completed.)

An interrupt is triggered only when all of these conditions are met at the beginning of an instruction. If different maskable interrupts meet these conditions simultaneously, the highest-priority interrupt will be serviced first, and the other pending interrupts must wait.

Upon Reset, all pending bits, individual enable bits, and the GIE bit are reset to zero. Thus, a maskable interrupt condition cannot trigger an interrupt until the program enables it by setting both the GIE bit and the individual enable bit. When enabling an interrupt, the user should consider whether or not a previously activated (set) pending bit should be acknowledged. If, at the time an interrupt is enabled, any previous occurrences of the interrupt should be ignored, the associated pending bit must be reset to zero prior to enabling the interrupt. Otherwise, the interrupt may be simply enabled; if the pending bit is already set, it will immediately trigger an interrupt. A maskable interrupt is active if its associated enable and pending bits are set.

An interrupt is an asynchronous event which may occur before, during, or after an instruction cycle. Any interrupt which occurs during the execution of an instruction is not acknowledged until the start of the next normally executed instruction. If the next normally executed instruction is to be skipped, the skip is performed before the pending interrupt is acknowledged.

At the start of interrupt acknowledgment, the following actions occur:

1. The GIE bit is automatically reset to zero, preventing any subsequent maskable interrupt from interrupting the current service routine. This feature prevents one maskable interrupt from interrupting another one being serviced.
2. The address of the instruction about to be executed is pushed onto the stack.
3. The program counter (PC) is loaded with 00FF Hex, causing a jump to that program memory location.

The device requires seven instruction cycles to perform the actions listed above.

If the user wishes to allow nested interrupts, the interrupts service routine may set the GIE bit to 1 by writing to the PSW register, and thus allow other maskable interrupts to interrupt the current service routine. If nested interrupts are allowed, caution must be exercised. The user must write the program in such a way as to prevent stack overflow, loss of saved context information, and other unwanted conditions.

The interrupt service routine stored at location 00FF Hex should use the VIS instruction to determine the cause of the interrupt, and jump to the interrupt handling routine corresponding to the highest priority enabled and active interrupt. Alternately, the user may choose to poll all interrupt pending and enable bits to determine the source(s) of the interrupt. If more than one interrupt is active, the user's program must decide which interrupt to service.

Within a specific interrupt service routine, the associated pending bit should be cleared. This is typically done as early as possible in the service routine in order to avoid missing the next occurrence of the same type of interrupt event. Thus, if the same event occurs a second time, even while the first occurrence is still being serviced, the second occurrence will be serviced immediately upon return from the current interrupt routine.

An interrupt service routine typically ends with an RETI instruction. This instruction set the GIE bit back to 1, pops the address stored on the stack, and restores that address to the program counter. Program execution then proceeds with the next instruction that would have been executed had there been no interrupt. If there are any valid interrupts pending, the highest-priority interrupt is serviced immediately upon return from the previous interrupt.

**Note:** While executing from the Boot ROM for ISP or virtual E2 operations, the hardware will disable interrupts from occurring. The hardware will leave the GIE bit in its current state, and if set, the hardware interrupts will occur when execution is returned to Flash Memory. Subsequent interrupts, during ISP operation, from the same interrupt source will be lost.

## VIS INSTRUCTION

The general interrupt service routine, which starts at address 00FF Hex, must be capable of handling all types of interrupts. The VIS instruction, together with an interrupt vector table, directs the device to the specific interrupt handling routine based on the cause of the interrupt.

VIS is a single-byte instruction, typically used at the very beginning of the general interrupt service routine at address 00FF Hex, or shortly after that point, just after the code used for context switching. The VIS instruction determines which enabled and pending interrupt has the highest priority, and causes an indirect jump to the address corresponding to that interrupt source. The jump addresses (vectors) for all possible interrupts sources are stored in a vector table.

The vector table may be as long as 32 bytes (maximum of 16 vectors) and resides at the top of the 256-byte block containing the VIS instruction. However, if the VIS instruction is at the very top of a 256-byte block (such as at 00FF Hex), the vector table resides at the top of the next 256-byte block. Thus, if the VIS instruction is located somewhere between 00FF and 01DF Hex (the usual case), the vector table is located between addresses 01E0 and 01FF Hex. If the VIS instruction is located between 01FF and 02DF Hex, then the vector table is located between addresses 02E0 and 02FF Hex, and so on.

Each vector is 15 bits long and points to the beginning of a specific interrupt service routine somewhere in the 32-kbyte memory space. Each vector occupies two bytes of the vector table, with the higher-order byte at the lower address. The vectors are arranged in order of interrupt priority. The vector of the maskable interrupt with the lowest rank is located to 0yE0 (higher-order byte) and 0yE1 (lower-order byte). The next priority interrupt is located at 0yE2 and 0yE3, and so forth in increasing rank. The Software Trap has the highest rank and its vector is always located at 0yFE and 0yFF. The number of interrupts which can become active defines the size of the table.

**Table 35** shows the types of interrupts, the interrupt arbitration ranking, and the locations of the corresponding vectors in the vector table.

The vector table should be filled by the user with the memory locations of the specific interrupt service routines. For example, if the Software Trap routine is located at 0310 Hex, then the vector location 0yFE and -0yFF should contain the data 03 and 10 Hex, respectively. When a Software Trap interrupt occurs and the VIS instruction is executed, the program jumps to the address specified in the vector table.

The interrupt sources in the vector table are listed in order of rank, from highest to lowest priority. If two or more enabled and pending interrupts are detected at the same time, the one with the highest priority is serviced first. Upon return from the interrupt service routine, the next highest-level pending interrupt is serviced.

If the VIS instruction is executed, but no interrupts are enabled and pending, the lowest-priority interrupt vector is used, and a jump is made to the corresponding address in the vector table. This is an unusual occurrence and may be the result of an error. It can legitimately result from a change in the enable bits or pending flags prior to the execution of the VIS instruction, such as executing a single cycle instruction which clears an enable flag at the same time that the pending flag is set. It can also result, however, from inadvertent execution of the VIS command outside of the context of an interrupt.

The default VIS interrupt vector can be useful for applications in which time critical interrupts can occur during the servicing of another interrupt. Rather than restoring the program context (A, B, X, etc.) and executing the RETI instruction, an interrupt service routine can be terminated by returning to the VIS instruction. In this case, interrupts will be serviced in turn until no further interrupts are pending and the default VIS routine is started. After testing the GIE bit to ensure that execution is not erroneous, the routine should restore the program context and execute the RETI to return to the interrupted program.

This technique can save up to fifty instruction cycles ( $t_c$ ), or more, (25  $\mu$ s at 10 MHz oscillator) of latency for pending interrupts with a penalty of fewer than ten instruction cycles if no further interrupts are pending.

To ensure reliable operation, the user should always use the VIS instruction to determine the source of an interrupt. Although it is possible to poll the pending bits to detect the source of an interrupt, this practice is not recommended. The use of polling allows the standard arbitration ranking to be altered, but the reliability of the interrupt system is compromised. The polling routine must individually test the enable and pending bits of each maskable interrupt. If a Software Trap interrupt should occur, it will be serviced last, even though it should have the highest priority. Under certain conditions, a Software Trap could be triggered but not serviced, resulting in an inadvertent “locking out” of all maskable interrupts by the Software Trap pending flag. Problems such as this can be avoided by using VIS instruction.

**Table 35. Interrupt Vector Table**

Arbitration Ranking	Source Description		Vector Address <sup>(1)</sup> (Hi-Low Byte)
(1) Highest	Software	INTR Instruction	0yFE–0yFF
(2)	Reserved for NMI		0yFC–0yFD
(3)	External	G0	0yFA–0yFB
(4)	Timer T0	Underflow	0yF8–0yF9

(1) y is a variable which represents the VIS block. VIS and the vector table must be located in the same 256-byte block except if VIS is located at the last address of a block. In this case, the table must be in the next block.

**Table 35. Interrupt Vector Table (continued)**

Arbitration Ranking	Source Description		Vector Address <sup>(1)</sup> (Hi-Low Byte)
(5)	Timer T1	T1A/Underflow	0yF6–0yF7
(6)	Timer T1	T1B	0yF4–0yF5
(7)	MICROWIRE/PLUS	BUSY Low	0yF2–0yF3
(8)	Reserved		0yF0–0yF1
(9)	USART	Receive	0yEE–0yEF
(10)	USART	Transmit	0yEC–0yED
(11)	Timer T2	T2A/Underflow	0yEA–0yEB
(12)	Timer T2	T2B	0yE8–0yE9
(13)	Timer T3	T2A/Underflow	0yE6–0yE7
(14)	Timer T3	T3B	0yE4–0yE5
(15)	Port L/Wakeup	Port L Edge	0yE2–0yE3
(16) Lowest	Default VIS	Reserved	0yE0–0yE1

**VIS Execution**

When the VIS instruction is executed it activates the arbitration logic. The arbitration logic generates an even number between E0 and FE (E0, E2, E4, E6 etc....) depending on which active interrupt has the highest arbitration ranking at the time of the 1st cycle of VIS is executed. For example, if the software trap interrupt is active, FE is generated. If the external interrupt is active and the software trap interrupt is not, then FA is generated and so forth. If no active interrupt is pending, than E0 is generated. This number replaces the lower byte of the PC. The upper byte of the PC remains unchanged. The new PC is therefore pointing to the vector of the active interrupt with the highest arbitration ranking. This vector is read from program memory and placed into the PC which is now pointed to the 1st instruction of the service routine of the active interrupt with the highest arbitration ranking.

Figure 34 illustrates the different steps performed by the VIS instruction. Figure 35 shows a flowchart for the VIS instruction.

The non-maskable interrupt pending flag is cleared by the RPND (Reset Non-Maskable Pending Bit) instruction (under certain conditions) and upon RESET.

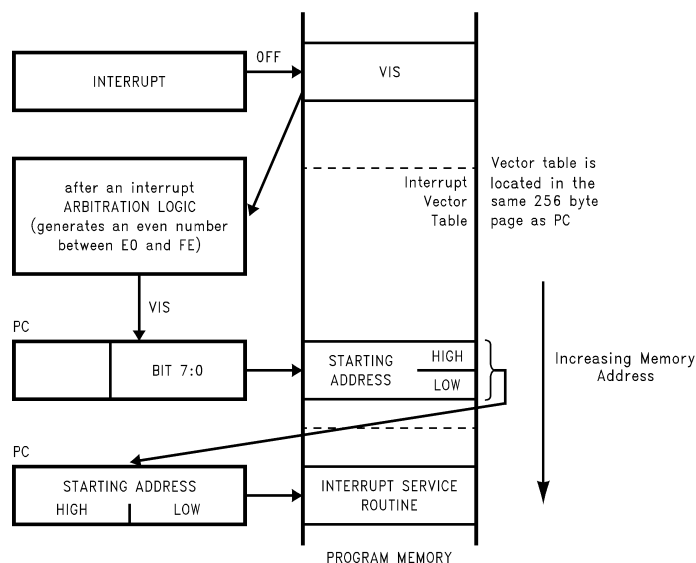

**Figure 34. VIS Operation**

## NON-MASKABLE INTERRUPT

### *Pending Flag*

There is a pending flag bit associated with the non-maskable Software Trap interrupt, called STPND. This pending flag is not memory-mapped and cannot be accessed directly by the software.

The pending flag is reset to zero when a device Reset occurs. When the non-maskable interrupt occurs, the associated pending bit is set to 1. The interrupt service routine should contain an RPND instruction to reset the pending flag to zero. The RPND instruction always resets the STPND flag.

### *Software Trap*

The Software Trap is a special kind of non-maskable interrupt which occurs when the INTR instruction (used to acknowledge interrupts) is fetched from program memory and placed in the instruction register. This can happen in a variety of ways, usually because of an error condition. Some examples of causes are listed below.

If the program counter incorrectly points to a memory location beyond the programmed Flash memory space, the unused memory location returns zeros which is interpreted as the INTR instruction.

If the stack is popped beyond the allowed limit (address 06F Hex), a 7FFF will be loaded into the PC. Since the Option Register resides at this location, and to maintain the integrity of the stack overpop protection, the Flash memory will return a zero on an instruction fetch and a software trap will be triggered.

A Software Trap can be triggered by a temporary hardware condition such as a brownout or power supply glitch.

The Software Trap has the highest priority of all interrupts. When a Software Trap occurs, the STPND bit is set. The GIE bit is not affected and the pending bit (not accessible by the user) is used to inhibit other interrupts and to direct the program to the ST service routine with the VIS instruction. Nothing can interrupt a Software Trap service routine except for another Software Trap. The STPND can be reset only by the RPND instruction or a chip Reset.

The Software Trap indicates an unusual or unknown error condition. Generally, returning to normal execution at the point where the Software Trap occurred cannot be done reliably. Therefore, the Software Trap service routine should re-initialize the stack pointer and perform a recovery procedure that re-starts the software at some known point, similar to a device Reset, but not necessarily performing all the same functions as a device Reset. The routine must also execute the RPND instruction to reset the STPND flag. Otherwise, all other interrupts will be locked out. To the extent possible, the interrupt routine should record or indicate the context of the device so that the cause of the Software Trap can be determined.

If the user wishes to return to normal execution from the point at which the Software Trap was triggered, the user must first execute RPND, followed by RETSK rather than RETI or RET. This is because the return address stored on the stack is the address of the INTR instruction that triggered the interrupt. The program must skip that instruction in order to proceed with the next one. Otherwise, an infinite loop of Software Traps and returns will occur.

Programming a return to normal execution requires careful consideration. If the Software Trap routine is interrupted by another Software Trap, the RPND instruction in the service routine for the second Software Trap will reset the STPND flag; upon return to the first Software Trap routine, the STPND flag will have the wrong state. This will allow maskable interrupts to be acknowledged during the servicing of the first Software Trap. To avoid problems such as this, the user program should contain the Software Trap routine to perform a recovery procedure rather than a return to normal execution.

Under normal conditions, the STPND flag is reset by a RPND instruction in the Software Trap service routine. If a programming error or hardware condition (brownout, power supply glitch, etc.) sets the STPND flag without providing a way for it to be cleared, all other interrupts will be locked out. To alleviate this condition, the user can use extra RPND instructions in the main program and in the Watchdog service routine (if present). There is no harm in executing extra RPND instructions in these parts of the program.

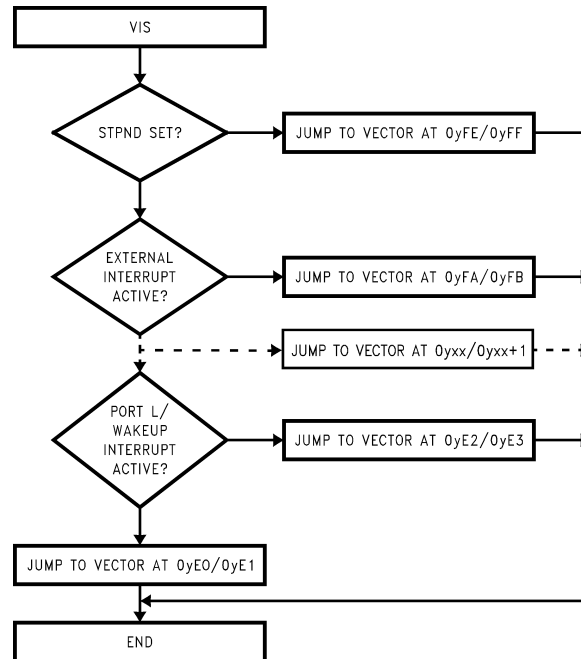

Figure 35. VIS Flow Chart

**Programming Example: External Interrupt**

```

PSW                =00EF
CNTRL              =00EE
RBIT               0,PORTGC
RBIT               0,PORTGD           ; G0 pin configured Hi-Z
SBIT               IEDG, CNTRL       ; Ext interrupt polarity; falling edge
SBIT               GIE, PSW         ; Set the GIE bit
SBIT               EXEN, PSW        ; Enable the external interrupt
WAIT:              JP               WAIT           ; Wait for external interrupt
.
.
.
.=0FF              ; The interrupt causes a
VIS                ; branch to address 0FF
; The VIS causes a branch to
; interrupt vector table
.
.
.=01FA            ; Vector table (within 256 byte
.ADDRW SERVICE    ; of VIS inst.) containing the ext
; interrupt service routine
.
.
SERVICE:                                     ; Interrupt Service Routine
RBIT,EXPND,PSW   ; Reset ext interrupt pend. bit
.
.
RET I                                                    ; Return, set the GIE bit
  
```

**PORT L INTERRUPTS**

Port L provides the user with an additional eight fully selectable, edge sensitive interrupts which are all vectored into the same service subroutine.

The interrupt from Port L shares logic with the wake-up circuitry. The register WKEN allows interrupts from Port L to be individually enabled or disabled. The register WKEDG specifies the trigger condition to be either a positive or a negative edge. Finally, the register WKPND latches in the pending trigger conditions.

The GIE (Global Interrupt Enable) bit enables the interrupt function.

A control flag, LPEN, functions as a global interrupt enable for Port L interrupts. Setting the LPEN flag will enable interrupts and vice versa. A separate global pending flag is not needed since the register WKPND is adequate.

Since Port L is also used for waking the device out of the HALT or IDLE modes, the user can elect to exit the HALT or IDLE modes either with or without the interrupt enabled. If he elects to disable the interrupt, then the device will restart execution from the instruction immediately following the instruction that placed the microcontroller in the HALT or IDLE modes. In the other case, the device will first execute the interrupt service routine and then revert to normal operation. (See HALT MODE for clock option wake-up information.)

## INTERRUPT SUMMARY

The device uses the following types of interrupts, listed below in order of priority:

1. The Software Trap non-maskable interrupt, triggered by the INTR (00 opcode) instruction. The Software Trap is acknowledged immediately. This interrupt service routine can be interrupted only by another Software Trap. The Software Trap should end with two RPND instructions followed by a re-start procedure.
2. Maskable interrupts, triggered by an on-chip peripheral block or an external device connected to the device. Under ordinary conditions, a maskable interrupt will not interrupt any other interrupt routine in progress. A maskable interrupt routine in progress can be interrupted by the non-maskable interrupt request. A maskable interrupt routine should end with an RETI instruction or, prior to restoring context, should return to execute the VIS instruction. This is particularly useful when exiting long interrupt service routines if the time between interrupts is short. In this case the RETI instruction would only be executed when the default VIS routine is reached.
3. While executing from the Boot ROM for ISP or virtual E2 operations, the hardware will disable interrupts from occurring. The hardware will leave the GIE bit in its current state, and if set, the hardware interrupts will occur when execution is returned to Flash Memory. Subsequent interrupts, during ISP operation, from the same interrupt source will be lost.

## WATCHDOG/Clock Monitor

The devices contain a user selectable WATCHDOG and clock monitor. The following section is applicable only if the WATCHDOG feature has been selected in the Option register. The WATCHDOG is designed to detect the user program getting stuck in infinite loops resulting in loss of program control or “runaway” programs.

The WATCHDOG logic contains two separate service windows. While the user programmable upper window selects the WATCHDOG service time, the lower window provides protection against an infinite program loop that contains the WATCHDOG service instruction. The WATCHDOG uses the Idle Timer (T0) and thus all times are measured in Idle Timer Clocks.

The Clock Monitor is used to detect the absence of a clock or a very slow clock below a specified rate on  $t_C$ .

The WATCHDOG consists of two independent logic blocks: WD UPPER and WD LOWER. WD UPPER establishes the upper limit on the service window and WD LOWER defines the lower limit of the service window.

Servicing the WATCHDOG consists of writing a specific value to a WATCHDOG Service Register named WDSVR which is memory mapped in the RAM. This value is composed of three fields, consisting of a 2-bit Window Select, a 5-bit Key Data field, and the 1-bit Clock Monitor Select field. [Table 36](#) shows the WDSVR register.

**Table 36. WATCHDOG Service Register (WDSVR)**

Window Select		Key Data					Clock Monitor
X	X	0	1	1	0	0	Y
7	6	5	4	3	2	1	0

The lower limit of the service window is fixed at 2048 Idle Timer Clocks. Bits 7 and 6 of the WDSVR register allow the user to pick an upper limit of the service window.

Table 37 shows the four possible combinations of lower and upper limits for the WATCHDOG service window. This flexibility in choosing the WATCHDOG service window prevents any undue burden on the user software.

Bits 5, 4, 3, 2 and 1 of the WDSVR register represent the 5-bit Key Data field. The key data is fixed at 01100. Bit 0 of the WDSVR Register is the Clock Monitor Select bit.

**Table 37. WATCHDOG Service Window Select**

WDSVR Bit 7	WDSVR Bit 6	Clock Monitor Bit 0	Service Window for High Speed Mode (Lower-Upper Limits)	Service Window for Dual Clock & Low Speed Modes (Lower-Upper Limits)
0	0	X	2048-8k $t_C$ Cycles	2048-8k Cycles of 32 kHz Clk
0	1	X	2048-16k $t_C$ Cycles	2048-16k Cycles of 32 kHz Clk
1	0	X	2048-32k $t_C$ Cycles	2048-32k Cycles of 32 kHz Clk
1	1	X	2048-64k $t_C$ Cycles	2048-64k Cycles of 32 kHz Clk
X	X	0	Clock Monitor Disabled	Clock Monitor Disabled
X	X	1	Clock Monitor Enabled	Clock Monitor Enabled

## CLOCK MONITOR

The Clock Monitor aboard the device can be selected or deselected under program control. The Clock Monitor is specified not to reject the clock if the instruction cycle clock ( $1/t_C$ ) is greater or equal to 5 kHz. This equates to a clock input rate on the selected oscillator of greater or equal to 25 kHz.

## WATCHDOG/CLOCK MONITOR OPERATION

The WATCHDOG is enabled by bit 2 of the Option register. When this Option bit is 0, the WATCHDOG is enabled and pin G1 becomes the WATCHDOG output with a weak pull-up.

The WATCHDOG and Clock Monitor are disabled during reset. The device comes out of reset with the WATCHDOG armed, the WATCHDOG Window Select bits (bits 6, 7 of the WDSVR Register) set, and the Clock Monitor bit (bit 0 of the WDSVR Register) enabled. Thus, a Clock Monitor error will occur after coming out of reset, if the instruction cycle clock frequency has not reached a minimum specified value, including the case where the oscillator fails to start.

The WDSVR register can be written to only once after reset and the key data (bits 5 through 1 of the WDSVR Register) must match to be a valid write. This write to the WDSVR register involves two irrevocable choices: (i) the selection of the WATCHDOG service window (ii) enabling or disabling of the Clock Monitor. Hence, the first write to WDSVR Register involves selecting or deselecting the Clock Monitor, select the WATCHDOG service window and match the WATCHDOG key data. Subsequent writes to the WDSVR register will compare the value being written by the user to the WATCHDOG service window value, the key data and the Clock Monitor Enable (all bits) in the WDSVR Register. Table 38 shows the sequence of events that can occur.

The user must service the WATCHDOG at least once before the upper limit of the service window expires. The WATCHDOG may not be serviced more than once in every lower limit of the service window.

When jumping to the boot ROM for ISP and virtual E2 operations, the hardware will disable the lower window error and perform an immediate WATCHDOG service. The ISP routines will service the WATCHDOG within the selected upper window. The ISP routines will service the WATCHDOG immediately prior to returning execution back to the user's code in flash. Therefore, after returning to flash memory, the user can service the WATCHDOG anytime following the return from boot ROM, but must service it within the selected upper window to avoid a WATCHDOG error.

The WATCHDOG has an output pin associated with it. This is the WDOUT pin, on pin 1 of the port G. WDOUT is active low. The WDOUT pin has a weak pull-up in the inactive state. Upon triggering the WATCHDOG, the logic will pull the WDOUT (G1) pin low for an additional 16–32 cycles after the signal level on WDOUT pin goes below the lower Schmitt trigger threshold. After this delay, the device will stop forcing the WDOUT output low. The WATCHDOG service window will restart when the WDOUT pin goes high.

A WATCHDOG service while the WDOUT signal is active will be ignored. The state of the WDOUT pin is not specified on reset, but if it powers up low then the WATCHDOG will time out and WDOUT will go high.

The Clock Monitor forces the G1 pin low upon detecting a clock frequency error. The Clock Monitor error will continue until the clock frequency has reached the minimum specified value, after which the G1 output will go high following 16–32 clock cycles. The Clock Monitor generates a continual Clock Monitor error if the oscillator fails to start, or fails to reach the minimum specified frequency. The specification for the Clock Monitor is as follows:

$1/t_C > 5 \text{ kHz}$ —No clock rejection.

$1/t_C < 10 \text{ Hz}$ —Ensured clock rejection.

**Table 38. WATCHDOG Service Actions**

Key Data	Window Data	Clock Monitor	Action
Match	Match	Match	Valid Service: Restart Service Window
Don't Care	Mismatch	Don't Care	Error: Generate WATCHDOG Output
Mismatch	Don't Care	Don't Care	Error: Generate WATCHDOG Output
Don't Care	Don't Care	Mismatch	Error: Generate WATCHDOG Output

## WATCHDOG AND CLOCK MONITOR SUMMARY

The following salient points regarding the WATCHDOG and CLOCK MONITOR should be noted:

- Both the WATCHDOG and CLOCK MONITOR detector circuits are inhibited during RESET.
- Following RESET, the WATCHDOG and CLOCK MONITOR are both enabled, with the WATCHDOG having the maximum service window selected.
- The WATCHDOG service window and CLOCK MONITOR enable/disable option can only be changed once, during the initial WATCHDOG service following RESET.
- The initial WATCHDOG service must match the key data value in the WATCHDOG Service register WDSVR in order to avoid a WATCHDOG error.
- Subsequent WATCHDOG services must match all three data fields in WDSVR in order to avoid WATCHDOG errors.
- The correct key data value cannot be read from the WATCHDOG Service register WDSVR. Any attempt to read this key data value of 01100 from WDSVR will read as key data value of all 0's.
- The WATCHDOG detector circuit is inhibited during both the HALT and IDLE modes.
- The CLOCK MONITOR detector circuit is active during both the HALT and IDLE modes. Consequently, the device inadvertently entering the HALT mode will be detected as a CLOCK MONITOR error (provided that the CLOCK MONITOR enable option has been selected by the program). Likewise, a device with WATCHDOG enabled in the Option but with the WATCHDOG output not connected to RESET, will draw excessive HALT current if placed in the HALT mode. The clock Monitor will pull the WATCHDOG output low and sink current through the on-chip pull-up resistor.
- The WATCHDOG service window will be set to its selected value from WDSVR following HALT. Consequently, the WATCHDOG should not be serviced for at least 2048 Idle Timer clocks following HALT, but must be serviced within the selected window to avoid a WATCHDOG error.
- The IDLE timer T0 is not initialized with external RESET.
- The user can sync in to the IDLE counter cycle with an IDLE counter (T0) interrupt or by monitoring the TOPND flag. The TOPND flag is set whenever the selected bit of the IDLE counter toggles (every 4, 8, 16, 32 or 64k Idle Timer clocks). The user is responsible for resetting the TOPND flag.
- A hardware WATCHDOG service occurs just as the device exits the IDLE mode. Consequently, the WATCHDOG should not be serviced for at least 2048 Idle Timer clocks following IDLE, but must be serviced within the selected window to avoid a WATCHDOG error.
- Following RESET, the initial WATCHDOG service (where the service window and the CLOCK MONITOR enable/disable must be selected) may be programmed anywhere within the maximum service window (65,536 instruction cycles) initialized by RESET. Note that this initial WATCHDOG service may be programmed within the initial 2048 instruction cycles without causing a WATCHDOG error.
- When using any of the ISP functions in Boot ROM, the ISP routines will service the WATCHDOG within the selected upper window. Upon return to flash memory, the WATCHDOG is serviced, the lower window is

enabled, and the user can service the WATCHDOG anytime following exit from Boot ROM, but must service it within the selected upper window to avoid a WATCHDOG error.

## DETECTION OF ILLEGAL CONDITIONS

The device can detect various illegal conditions resulting from coding errors, transient noise, power supply voltage drops, runaway programs, etc.

Reading of unprogrammed ROM gets zeros. The opcode for software interrupt is 00. If the program fetches instructions from unprogrammed ROM, this will force a software interrupt, thus signaling that an illegal condition has occurred.

The subroutine stack grows down for each call (jump to subroutine), interrupt, or PUSH, and grows up for each return or POP. The stack pointer is initialized to RAM location 06F Hex during reset. Consequently, if there are more returns than calls, the stack pointer will point to addresses 070 and 071 Hex (which are undefined RAM). Undefined RAM from addresses 070 to 07F (Segment 0), and all other segments (i.e., Segments 4... etc.) is read as all 1's, which in turn will cause the program to return to address 7FFF Hex. The Option Register is located at this location and, when accessed by an instruction fetch, will respond with an INTR instruction (all 0's) to generate a software interrupt, signalling an illegal condition on overpop of the stack.

Thus, the chip can detect the following illegal conditions:

1. Executing from undefined Program Memory
2. Over "POP"ing the stack by having more returns than calls.

When the software interrupt occurs, the user can re-initialize the stack pointer and do a recovery procedure before restarting (this recovery program is probably similar to that following reset, but might not contain the same program initialization procedures). The recovery program should reset the software interrupt pending bit using the RPND instruction.

## MICROWIRE/PLUS

MICROWIRE/PLUS is a serial SPI compatible synchronous communications interface. The MICROWIRE/PLUS capability enables the device to interface with MICROWIRE/PLUS or SPI peripherals (i.e. A/D converters, display drivers, EEPROMs etc.) and with other microcontrollers which support the MICROWIRE/PLUS or SPI interface. It consists of an 8-bit serial shift register (SIO) with serial data input (SI), serial data output (SO) and serial shift clock (SK). [Figure 36](#) shows a block diagram of the MICROWIRE/PLUS logic.

The shift clock can be selected from either an internal source or an external source. Operating the MICROWIRE/PLUS arrangement with the internal clock source is called the Master mode of operation. Similarly, operating the MICROWIRE/PLUS arrangement with an external shift clock is called the Slave mode of operation.

The CNTRL register is used to configure and control the MICROWIRE/PLUS mode. To use the MICROWIRE/PLUS, the MSEL bit in the CNTRL register is set to one. In the master mode, the SK clock rate is selected by the two bits, SL0 and SL1, in the CNTRL register. [Table 39](#) details the different clock rates that may be selected.

**Table 39. MICROWIRE/PLUS Master Mode Clock Select<sup>(1)</sup>**

SL1	SL0	SK Period
0	0	$2 \times t_C$
0	1	$4 \times t_C$
1	x	$8 \times t_C$

(1) Where  $t_C$  is the instruction cycle clock

## MICROWIRE/PLUS OPERATION

Setting the BUSY bit in the PSW register causes the MICROWIRE/PLUS to start shifting the data. It gets reset when eight data bits have been shifted. The user may reset the BUSY bit by software to allow less than 8 bits to shift. If enabled, an interrupt is generated when eight data bits have been shifted. The device may enter the MICROWIRE/PLUS mode either as a Master or as a Slave. [Figure 36](#) shows how two microcontroller devices and several peripherals may be interconnected using the MICROWIRE/PLUS arrangements.

### WARNING

The SIO register should only be loaded when the SK clock is in the idle phase. Loading the SIO register while the SK clock is in the active phase, will result in undefined data in the SIO register.

Setting the BUSY flag when the input SK clock is in the active phase while in the MICROWIRE/PLUS is in the slave mode may cause the current SK clock for the SIO shift register to be narrow. For safety, the BUSY flag should only be set when the input SK clock is in the idle phase.

### MICROWIRE/PLUS Master Mode Operation

In the MICROWIRE/PLUS Master mode of operation the shift clock (SK) is generated internally. The MICROWIRE/PLUS Master always initiates all data exchanges. The MSEL bit in the CNTRL register must be set to enable the SO and SK functions onto the G Port. The SO and SK pins must also be selected as outputs by setting appropriate bits in the Port G configuration register. In the slave mode, the shift clock stops after 8 clock pulses. [Table 40](#) summarizes the bit settings required for Master mode of operation.

### MICROWIRE/PLUS Slave Mode Operation

In the MICROWIRE/PLUS Slave mode of operation the SK clock is generated by an external source. Setting the MSEL bit in the CNTRL register enables the SO and SK functions onto the G Port. The SK pin must be selected as an input and the SO pin is selected as an output pin by setting and resetting the appropriate bits in the Port G configuration register. [Table 40](#) summarizes the settings required to enter the Slave mode of operation.

**Table 40. MICROWIRE/PLUS Mode Settings<sup>(1)</sup>**

G4 (SO) Config. Bit	G5 (SK) Config. Bit	G4 Fun.	G5 Fun.	Operation
1	1	SO	Int.	MICROWIRE/PLUS Master
0	1	TRI- STATE	Int. SK	MICROWIRE/PLUS Master
1	0	SO	Ext. SK	MICROWIRE/PLUS Slave
0	0	TRI- STATE	Ext. SK	MICROWIRE/PLUS Slave

(1) This table assumes that the control flag MSEL is set.

The user must set the BUSY flag immediately upon entering the Slave mode. This ensures that all data bits sent by the Master is shifted properly. After eight clock pulses the BUSY flag is clear, the shift clock is stopped, and the sequence may be repeated.

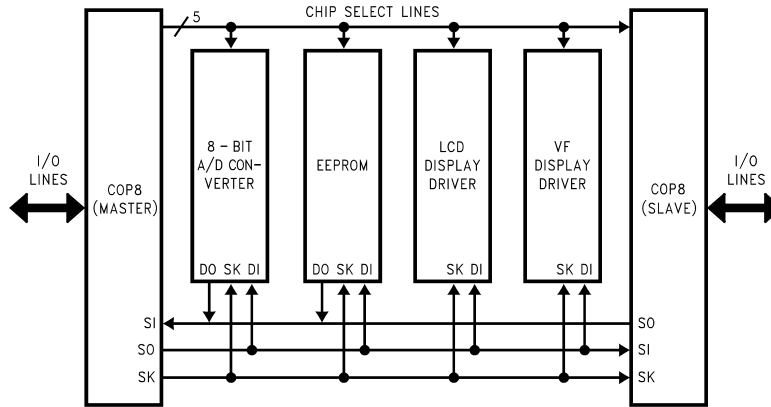

Figure 36. MICROWIRE/PLUS Application

**Alternate SK Phase Operation and SK Idle Polarity**

The device allows either the normal SK clock or an alternate phase SK clock to shift data in and out of the SIO register. In both the modes the SK idle polarity can be either high or low. The polarity is selected by bit 5 of Port G data register. In the normal mode data is shifted in on the rising edge of the SK clock and the data is shifted out on the falling edge of the SK clock. The SIO register is shifted on each falling edge of the SK clock. In the alternate SK phase operation, data is shifted in on the falling edge of the SK clock and shifted out on the rising edge of the SK clock. Bit 6 of Port G configuration register selects the SK edge.

A control flag, SKSEL, allows either the normal SK clock or the alternate SK clock to be selected. Refer to Table 41 for the appropriate setting of the SKSEL bit. The SKSEL is mapped into the G6 configuration bit. The SKSEL flag will power up in the reset condition, selecting the normal SK signal provided the SK Idle Polarity remains LOW.

Table 41. MICROWIRE/PLUS Shift Clock Polarity and Sample/Shift Phase

SK Phase	Port G		SO Clocked Out On:	SI Sampled On:	SK Idle Phase
	G6 (SKSEL) Config. Bit	G5 Data Bit			
Normal	0	0	SK Falling Edge	SK Rising Edge	Low
Alternate	1	0	SK Rising Edge	SK Falling Edge	Low
Alternate	0	1	SK Rising Edge	SK Falling Edge	High
Normal	1	1	SK Falling Edge	SK Rising Edge	High

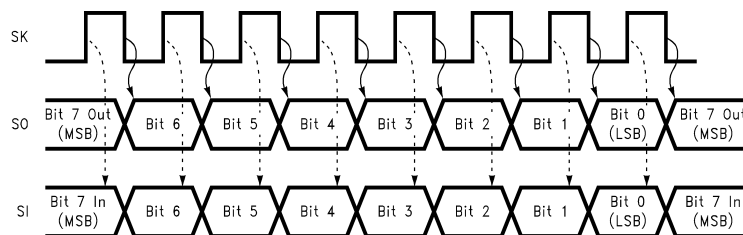

Figure 37. MICROWIRE/PLUS SPI Mode Interface Timing, Normal SK Mode, SK Idle Phase being Low

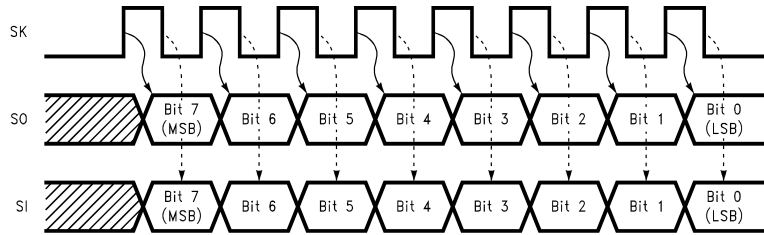

Figure 38. MICROWIRE/PLUS SPI Mode Interface Timing, Alternate SK Mode, SK Idle Phase being Low

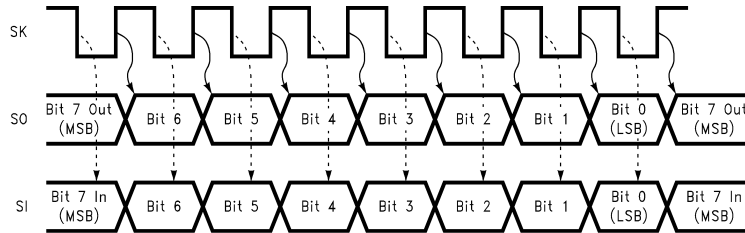

Figure 39. MICROWIRE/PLUS SPI Mode Interface Timing, Normal SK Mode, SK Idle Phase being High

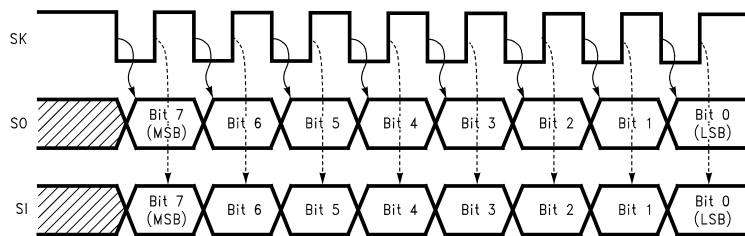

Figure 40. MICROWIRE/PLUS SPI Mode Interface Timing, Alternate SK Mode, SK Idle Phase being High

### Memory Map

All RAM, ports and registers (except A and PC) are mapped into data memory address space.

Address S/ADD REG	Contents
0000 to 006F	On-Chip RAM bytes (112 bytes)
0070 to 007F	Unused RAM Address Space (Reads As All Ones)
xx80 to xx90	Unused RAM Address Space (Reads As Undefined Data)
xx90 to xx9B	Reserved
xx9C	Programmable Gain Amplifier Offset Trim Register for N Channel Pair (AMPTRMN)
xx9D	Programmable Gain Amplifier Offset Trim Register for P Channel Pair (AMPTRMP)
xx9E	Reserved
xx9F	Reserved
xxA0 to xxA3	Reserved
xxA4	Port B Data Register
xxA5	Port B Configuration Register
xxA6	Port B Input Pins (Read Only)
xxA7	Reserved for Port B
xxA8	ISP Address Register Low Byte (ISPADLO)
xxA9	ISP Address Register High Byte (ISPADHI)
xxAA	ISP Read Data Register (ISPRD)

Address S/ADD REG	Contents
xxAB	ISP Write Data Register (ISPWR)
xxAC to xxAE	Reserved
xxAF	High Speed Timers Control Register (HSTCR)
xxB0	Timer T3 Lower Byte
xxB1	Timer T3 Upper Byte
xxB2	Timer T3 Autoload Register T3RA Lower Byte
xxB3	Timer T3 Autoload Register T3RA Upper Byte
xxB4	Timer T3 Autoload Register T3RB Lower Byte
xxB5	Timer T3 Autoload Register T3RB Upper Byte
xxB6	Timer T3 Control Register
xxB7	Reserved
xxB8	USART Transmit Buffer (TBUF)
xxB9	USART Receive Buffer (RBUF)
xxBA	USART Control and Status Register (ENU)
xxBB	USART Receive Control and Status Register (ENUR)
xxBC	USART Interrupt and Clock Source Register (ENUI)
xxBD	USART Baud Register (BAUD)
xxBE	USART Prescale Select Register (PSR)
xxBF	Reserved
xxC0	Timer T2 Lower Byte
xxC1	Timer T2 Upper Byte
xxC2	Timer T2 Autoload Register T2RA Lower Byte
xxC3	Timer T2 Autoload Register T2RA Upper Byte
xxC4	Timer T2 Autoload Register T2RB Lower Byte
xxC5	Timer T2 Autoload Register T2RB Upper Byte
xxC6	Timer T2 Control Register
xxC7	WATCHDOG Service Register (Reg:WDSVR)
xxC8	MIWU Edge Select Register (Reg:WKEDG)
xxC9	MIWU Enable Register (Reg:WKEN)
xxCA	MIWU Pending Register (Reg:WKPND)
xxCB	A/D Converter Control Register (ENAD)
xxCC	A/D Converter Result Register High Byte (ADRSTH)
xxCD	A/D Converter Result Register Low Byte (ADRSTL)
xxCE	A/D Amplifier Gain Register (ADGAIN)
xxCF	Idle Timer Control Register (ITMR)
xxD0	Port L Data Register
xxD1	Port L Configuration Register
xxD2	Port L Input Pins (Read Only)
xxD3	Reserved
xxD4	Port G Data Register
xxD5	Port G Configuration Register
xxD6	Port G Input Pins (Read Only)
xxD7 to xxDF	Reserved
xxE0	Reserved
xxE1	E2 and Flash Memory Write Timing Register (PGMTIM)
xxE2	ISP Key Register (ISPKEY)
xxE3 to xxE5	Reserved
xxE6	Timer T1 Autoload Register T1RB Lower Byte

Address	Contents
S/ADD REG	
xxE7	Timer T1 Autoload Register T1RB Upper Byte
xxE8	ICNTRL Register
xxE9	MICROWIRE/PLUS Shift Register
xxEA	Timer T1 Lower Byte
xxEB	Timer T1 Upper Byte
xxEC	Timer T1 Autoload Register T1RA Lower Byte
xxED	Timer T1 Autoload Register T1RA Upper Byte
xxEE	CNTRL Control Register
xxEF	PSW Register
xxF0 to FB	On-Chip RAM Mapped as Registers
xxFC	X Register
xxFD	SP Register
xxFE	B Register
xxFF	S Register
0100 to 017F	On-Chip 128 RAM Bytes
0200 to 027F	On-Chip 128 RAM Bytes
0300 to 037F	On-Chip 128 RAM Bytes

#### NOTE

Reading memory locations 0070H–007FH (Segment 0) will return all ones. Reading unused memory locations 0080H–0093H (Segment 0) will return undefined data. Reading memory locations from other Segments (i.e., Segment 4, Segment 5, ... etc.) will return undefined data.

## Instruction Set

### INTRODUCTION

This section defines the instruction set of the COP8 Family members. It contains information about the instruction set features, addressing modes and types.

### INSTRUCTION FEATURES

The strength of the instruction set is based on the following features:

- Mostly single-byte opcode instructions minimize program size.
- One instruction cycle for the majority of single-byte instructions to minimize program execution time.
- Many single-byte, multiple function instructions such as DRSZ.
- Three memory mapped pointers: two for register indirect addressing, and one for the software stack.
- Sixteen memory mapped registers that allow an optimized implementation of certain instructions.
- Ability to set, reset, and test any individual bit in data memory address space, including the memory-mapped I/O ports and registers.
- Register-Indirect LOAD and EXCHANGE instructions with optional automatic post-incrementing or decrementing of the register pointer. This allows for greater efficiency (both in cycle time and program code) in loading, walking across and processing fields in data memory.
- Unique instructions to optimize program size and throughput efficiency. Some of these instructions are: DRSZ, IFBNE, DCOR, RETSK, VIS and RRC.

## ADDRESSING MODES

The instruction set offers a variety of methods for specifying memory addresses. Each method is called an addressing mode. These modes are classified into two categories: operand addressing modes and transfer-of-control addressing modes. Operand addressing modes are the various methods of specifying an address for accessing (reading or writing) data. Transfer-of-control addressing modes are used in conjunction with jump instructions to control the execution sequence of the software program.

### Operand Addressing Modes

The operand of an instruction specifies what memory location is to be affected by that instruction. Several different operand addressing modes are available, allowing memory locations to be specified in a variety of ways. An instruction can specify an address directly by supplying the specific address, or indirectly by specifying a register pointer. The contents of the register (or in some cases, two registers) point to the desired memory location. In the immediate mode, the data byte to be used is contained in the instruction itself.

Each addressing mode has its own advantages and disadvantages with respect to flexibility, execution speed, and program compactness. Not all modes are available with all instructions. The Load (LD) instruction offers the largest number of addressing modes.

The available addressing modes are:

- Direct
- Register B or X Indirect
- Register B or X Indirect with Post-Incrementing/Decrementing
- Immediate
- Immediate Short
- Indirect from Program Memory

The addressing modes are described below. Each description includes an example of an assembly language instruction using the described addressing mode.

**Direct.** The memory address is specified directly as a byte in the instruction. In assembly language, the direct address is written as a numerical value (or a label that has been defined elsewhere in the program as a numerical value).

**Example:** Load Accumulator Memory Direct

LD A,05

Reg/Data	Contents	Contents
Memory	Before	After
Accumulator	XX Hex	A6 Hex
Memory Location	A6 Hex	A6 Hex
0005 Hex		

**Register B or X Indirect.** The memory address is specified by the contents of the B Register or X register (pointer register). In assembly language, the notation [B] or [X] specifies which register serves as the pointer.

**Example:** Exchange Memory with Accumulator, B Indirect

X A,[B]

Reg/Data	Contents	Contents
Memory	Before	After
Accumulator	01 Hex	87 Hex
Memory Location	87 Hex	01 Hex
0005 Hex		
B Pointer	05 Hex	05 Hex

**Register B or X Indirect with Post-Incrementing/Decrementing.** The relevant memory address is specified by the contents of the B Register or X register (pointer register). The pointer register is automatically incremented or decremented after execution, allowing easy manipulation of memory blocks with software loops. In assembly language, the notation [B+], [B-], [X+], or [X-] specifies which register serves as the pointer, and whether the pointer is to be incremented or decremented.

**Example:** Exchange Memory with Accumulator, B Indirect with Post-Increment

X A,[B+]

Reg/Data	Contents	Contents
Memory	Before	After
Accumulator	03 Hex	62 Hex
Memory Location	62 Hex	03 Hex
0005 Hex		
B Pointer	05 Hex	06 Hex

**Intermediate.** The data for the operation follows the instruction opcode in program memory. In assembly language, the number sign character (#) indicates an immediate operand.

**Example:** Load Accumulator Immediate

LD A,#05

Reg/Data	Contents	Contents
Memory	Before	After
Accumulator	XX Hex	05 Hex

**Immediate Short.** This is a special case of an immediate instruction. In the “Load B immediate” instruction, the 4-bit immediate value in the instruction is loaded into the lower nibble of the B register. The upper nibble of the B register is reset to 0000 binary.

**Example:** Load B Register Immediate Short

LD B,#7

Reg/Data	Contents	Contents
Memory	Before	After
B Pointer	12 Hex	07 Hex

**Indirect from Program Memory.** This is a special case of an indirect instruction that allows access to data tables stored in program memory. In the “Load Accumulator Indirect” (LAID) instruction, the upper and lower bytes of the Program Counter (PCU and PCL) are used temporarily as a pointer to program memory. For purposes of accessing program memory, the contents of the Accumulator and PCL are exchanged. The data pointed to by the Program Counter is loaded into the Accumulator, and simultaneously, the original contents of PCL are restored so that the program can resume normal execution.

**Example:** Load Accumulator Indirect

LAID

Reg/Data	Contents	Contents
Memory	Before	After
PCU	04 Hex	04 Hex
PCL	35 Hex	36 Hex
Accumulator	1F Hex	25 Hex
Memory Location	25 Hex	25 Hex
041F Hex		

### Transfer-of-Control Addressing Modes

Program instructions are usually executed in sequential order. However, Jump instructions can be used to change the normal execution sequence. Several transfer-of-control addressing modes are available to specify jump addresses.

A change in program flow requires a non-incremental change in the Program Counter contents. The Program Counter consists of two bytes, designated the upper byte (PCU) and lower byte (PCL). The most significant bit of PCU is not used, leaving 15 bits to address the program memory.

Different addressing modes are used to specify the new address for the Program Counter. The choice of addressing mode depends primarily on the distance of the jump. Farther jumps sometimes require more instruction bytes in order to completely specify the new Program Counter contents.

The available transfer-of-control addressing modes are:

- Jump Relative
- Jump Absolute
- Jump Absolute Long
- Jump Indirect

The transfer-of-control addressing modes are described below. Each description includes an example of a Jump instruction using a particular addressing mode, and the effect on the Program Counter bytes of executing that instruction.

**Jump Relative.** In this 1-byte instruction, six bits of the instruction opcode specify the distance of the jump from the current program memory location. The distance of the jump can range from –31 to +32. A JP+1 instruction is not allowed. The programmer should use a NOP instead.

**Example:** Jump Relative

JP 0A

Reg	Contents	Contents
	Before	After
PCU	02 Hex	02 Hex
PCL	05 Hex	0F Hex

**Jump Absolute.** In this 2-byte instruction, 12 bits of the instruction opcode specify the new contents of the Program Counter. The upper three bits of the Program Counter remain unchanged, restricting the new Program Counter address to the same 4k-byte address space as the current instruction. (This restriction is relevant only in devices using more than one 4k-byte program memory space.)

**Example:** Jump Absolute

JMP 0125

Reg	Contents	Contents
	Before	After
PCU	0C Hex	01 Hex
PCL	77 Hex	25 Hex

**Jump Absolute Long.** In this 3-byte instruction, 15 bits of the instruction opcode specify the new contents of the Program Counter.

**Example:** Jump Absolute Long

JMP 03625

Reg/ Memory	Contents	Contents
	Before	After
PCU	42 Hex	36 Hex
PCL	36 Hex	25 Hex

**Jump Indirect.** In this 1-byte instruction, the lower byte of the jump address is obtained from a table stored in program memory, with the Accumulator serving as the low order byte of a pointer into program memory. For purposes of accessing program memory, the contents of the Accumulator are written to PCL (temporarily). The data pointed to by the Program Counter (PCH/PCL) is loaded into PCL, while PCH remains unchanged.

**Example:** Jump Indirect

JID

Reg/	Contents	Contents
Memory	Before	After
PCU	01 Hex	01 Hex
PCL	C4 Hex	32 Hex
Accumulator	26 Hex	26 Hex
Memory		
Location	32 Hex	32 Hex
0126 Hex		

The VIS instruction is a special case of the Indirect Transfer of Control addressing mode, where the double-byte vector associated with the interrupt is transferred from adjacent addresses in program memory into the Program Counter in order to jump to the associated interrupt service routine.

## INSTRUCTION TYPES

The instruction set contains a wide variety of instructions. The available instructions are listed below, organized into related groups.

Some instructions test a condition and skip the next instruction if the condition is not true. Skipped instructions are executed as no-operation (NOP) instructions.

### *Arithmetic Instructions*

The arithmetic instructions perform binary arithmetic such as addition and subtraction, with or without the Carry bit.

- Add (ADD)
- Add with Carry (ADC)
- Subtract with Carry (SUBC)
- Increment (INC)
- Decrement (DEC)
- Decimal Correct (DCOR)
- Clear Accumulator (CLR)
- Set Carry (SC)
- Reset Carry (RC)

### *Transfer-of-Control Instructions*

The transfer-of-control instructions change the usual sequential program flow by altering the contents of the Program Counter. The Jump to Subroutine instructions save the Program Counter contents on the stack before jumping; the Return instructions pop the top of the stack back into the Program Counter.

- Jump Relative (JP)
- Jump Absolute (JMP)
- Jump Absolute Long (JMPL)
- Jump Indirect (JID)

- Jump to Subroutine (JSR)
- Jump to Subroutine Long (JSRL)
- Jump to Boot ROM Subroutine (JSRB)
- Return from Subroutine (RET)
- Return from Subroutine and Skip (RETSK)
- Return from Interrupt (RETI)
- Software Trap Interrupt (INTR)
- Vector Interrupt Select (VIS)

### ***Load and Exchange Instructions***

The load and exchange instructions write byte values in registers or memory. The addressing mode determines the source of the data.

- Load (LD)
- Load Accumulator Indirect (LAID)
- Exchange (X)

### ***Logical Instructions***

The logical instructions perform the operations AND, OR, and XOR (Exclusive OR). Other logical operations can be performed by combining these basic operations. For example, complementing is accomplished by exclusive-ORing the Accumulator with FF Hex.

- Logical AND (AND)
- Logical OR (OR)
- Exclusive OR (XOR)

### ***Accumulator Bit Manipulation Instructions***

The Accumulator bit manipulation instructions allow the user to shift the Accumulator bits and to swap its two nibbles.

- Rotate Right Through Carry (RRC)
- Rotate Left Through Carry (RLC)
- Swap Nibbles of Accumulator (SWAP)

### ***Stack Control Instructions***

- Push Data onto Stack (PUSH)
- Pop Data off of Stack (POP)

### ***Memory Bit Manipulation Instructions***

The memory bit manipulation instructions allow the user to set and reset individual bits in memory.

- Set Bit (SBIT)
- Reset Bit (RBIT)
- Reset Pending Bit (RPND)

### ***Conditional Instructions***

The conditional instruction test a condition. If the condition is true, the next instruction is executed in the normal manner; if the condition is false, the next instruction is skipped.

- If Equal (IFEQ)

If Not Equal (IFNE)  
 If Greater Than (IFGT)  
 If Carry (IFC)  
 If Not Carry (IFNC)  
 If Bit (IFBIT)  
 If B Pointer Not Equal (IFBNE)  
 And Skip if Zero (ANDSZ)  
 Decrement Register and Skip if Zero (DRSZ)

### No-Operation Instruction

The no-operation instruction does nothing, except to occupy space in the program memory and time in execution.

No-Operation (NOP)

**Note:** The VIS is a special case of the Indirect Transfer of Control addressing mode, where the double byte vector associated with the interrupt is transferred from adjacent addresses in the program memory into the program counter (PC) in order to jump to the associated interrupt service routine.

### REGISTER AND SYMBOL DEFINITION

The following abbreviations represent the nomenclature used in the instruction description and the COP8 cross-assembler.

Registers	
A	8-Bit Accumulator Register
B	8-Bit Address Register
X	8-Bit Address Register
S	8-Bit Segment Register
SP	8-Bit Stack Pointer Register
PC	15-Bit Program Counter Register
PU	Upper 7 Bits of PC
PL	Lower 8 Bits of PC
C	1 Bit of PSW Register for Carry
HC	1 Bit of PSW Register for Half Carry
GIE	1 Bit of PSW Register for Global Interrupt Enable
VU	Interrupt Vector Upper Byte
VL	Interrupt Vector Lower Byte

Symbols	
[B]	Memory Indirectly Addressed by B Register
[X]	Memory Indirectly Addressed by X Register
MD	Direct Addressed Memory
Mem	Direct Addressed Memory or [B]
MemI	Direct Addressed Memory or [B] or Immediate Data
Imm	8-Bit Immediate Data
Reg	Register Memory: Addresses F0 to FF (Includes B, X and SP)
Bit	Bit Number (0 to 7)
←	Loaded with
↔	Exchanged with

**INSTRUCTION SET SUMMARY**

ADD	A,Meml	ADD	$A \leftarrow A + \text{Meml}$
ADC	A,Meml	ADD with Carry	$A \leftarrow A + \text{Meml} + C$ , $C \leftarrow \text{Carry}$ , $\text{HC} \leftarrow \text{Half Carry}$
SUBC	A,Meml	Subtract with Carry	$A \leftarrow A - \overline{\text{Meml}} + C$ , $C \leftarrow \text{Carry}$ , $\text{HC} \leftarrow \text{Half Carry}$
AND	A,Meml	Logical AND	$A \leftarrow A \text{ and } \overline{\text{Meml}}$
ANDSZ	A,Imm	Logical AND Immed., Skip if Zero	Skip next if $(A \text{ and } \text{Imm}) = 0$
OR	A,Meml	Logical OR	$A \leftarrow A \text{ or } \text{Meml}$
XOR	A,Meml	Logical EXclusive OR	$A \leftarrow A \text{ xor } \text{Meml}$
IFEQ	MD,Imm	IF Equal	Compare MD and Imm, Do next if $\text{MD} = \text{Imm}$
IFEQ	A,Meml	IF Equal	Compare A and Meml, Do next if $A = \text{Meml}$
IFNE	A,Meml	IF Not Equal	Compare A and Meml, Do next if $A \neq \text{Meml}$
IFGT	A,Meml	IF Greater Than	Compare A and Meml, Do next if $A > \text{Meml}$
IFBNE	#	If B Not Equal	Do next if lower 4 bits of $B \neq \text{Imm}$
DRSZ	Reg	Decrement Reg., Skip if Zero	$\text{Reg} \leftarrow \text{Reg} - 1$ , Skip if $\text{Reg} = 0$
SBIT	#,Mem	Set BIT	1 to bit, Mem (bit = 0 to 7 immediate)
RBIT	#,Mem	Reset BIT	0 to bit, Mem
IFBIT	#,Mem	IF BIT	If bit #, A or Mem is true do next instruction
RPND		Reset PeNDing Flag	Reset Software Interrupt Pending Flag
X	A,Mem	EXchange A with Memory	$A \leftrightarrow \text{Mem}$
X	A,[X]	EXchange A with Memory [X]	$A \leftrightarrow [X]$
LD	A,Meml	LoaD A with Memory	$A \leftarrow \text{Meml}$
LD	A,[X]	LoaD A with Memory [X]	$A \leftarrow [X]$
LD	B,Imm	LoaD B with Immed.	$B \leftarrow \text{Imm}$
LD	Mem,Imm	LoaD Memory Immed.	$\text{Mem} \leftarrow \text{Imm}$
LD	Reg,Imm	LoaD Register Memory Immed.	$\text{Reg} \leftarrow \text{Imm}$
X	A, [B±]	EXchange A with Memory [B]	$A \leftrightarrow [B]$ , $(B \leftarrow B \pm 1)$
X	A, [X±]	EXchange A with Memory [X]	$A \leftrightarrow [X]$ , $(X \leftarrow X \pm 1)$
LD	A, [B±]	LoaD A with Memory [B]	$A \leftarrow [B]$ , $(B \leftarrow B \pm 1)$
LD	A, [X±]	LoaD A with Memory [X]	$A \leftarrow [X]$ , $(X \leftarrow X \pm 1)$
LD	[B±],Imm	LoaD Memory [B] Immed.	$[B] \leftarrow \text{Imm}$ , $(B \leftarrow B \pm 1)$
CLR	A	CLeaR A	$A \leftarrow 0$
INC	A	INCrement A	$A \leftarrow A + 1$
DEC	A	DECrement A	$A \leftarrow A - 1$
LAID		Load A InDirect from ROM	$A \leftarrow \text{ROM}(\text{PU}, A)$
DCOR	A	Decimal CORrect A	$A \leftarrow \text{BCD correction of A (follows ADC, SUBC)}$
RRC	A	Rotate A Right thru C	$C \rightarrow A7 \rightarrow \dots \rightarrow A0 \rightarrow C$
RLC	A	Rotate A Left thru C	$C \leftarrow A7 \leftarrow \dots \leftarrow A0 \leftarrow C$ , $\text{HC} \leftarrow A0$
SWAP	A	SWAP nibbles of A	$A7 \dots A4 \leftrightarrow A3 \dots A0$
SC		Set C	$C \leftarrow 1$ , $\text{HC} \leftarrow 1$
RC		Reset C	$C \leftarrow 0$ , $\text{HC} \leftarrow 0$
IFC		IF C	If C is true, do next instruction
IFNC		IF Not C	If C is not true, do next instruction
POP	A	POP the stack into A	$\text{SP} \leftarrow \text{SP} + 1$ , $A \leftarrow [\text{SP}]$
PUSH	A	PUSH A onto the stack	$[\text{SP}] \leftarrow A$ , $\text{SP} \leftarrow \text{SP} - 1$
VIS		Vector to Interrupt Service Routine	$\text{PU} \leftarrow [\text{VU}]$ , $\text{PL} \leftarrow [\text{VL}]$
JMPL	Addr.	Jump absolute Long	$\text{PC} \leftarrow \text{ii}$ (ii = 15 bits, 0 to 32k)
JMP	Addr.	Jump absolute	$\text{PC}9 \dots 0 \leftarrow \text{i}$ (i = 12 bits)

JP	Disp.	Jump relative short	$PC \leftarrow PC + r$ (r is -31 to +32, except 1)
JSRL	Addr.	Jump SubRoutine Long	$[SP] \leftarrow PL, [SP-1] \leftarrow PU, SP-2, PC \leftarrow i$
JSR	Addr.	Jump SubRoutine	$[SP] \leftarrow PL, [SP-1] \leftarrow PU, SP-2, PC9 \dots 0 \leftarrow i$
JSRB	Addr	Jump SubRoutine Boot ROM	$[SP] \leftarrow PL, [SP-1] \leftarrow PU, SP-2,$ $PL \leftarrow Addr, PU \leftarrow 00,$ switch to flash
JID		Jump InDirect	$PL \leftarrow ROM (PU, A)$
RET		RETurn from subroutine	$SP + 2, PL \leftarrow [SP], PU \leftarrow [SP-1]$
RETSK		RETurn and SKip	$SP + 2, PL \leftarrow [SP], PU \leftarrow [SP-1],$ skip next instruction
RETI		RETurn from Interrupt	$SP + 2, PL \leftarrow [SP], PU \leftarrow [SP-1], GIE \leftarrow 1$
INTR		Generate an Interrupt	$[SP] \leftarrow PL, [SP-1] \leftarrow PU, SP-2, PC \leftarrow 0FF$
NOP		No OPeration	$PC \leftarrow PC + 1$

### INSTRUCTION EXECUTION TIME

Most instructions are single byte (with immediate addressing mode instructions taking two bytes).

Most single byte instructions take one cycle time to execute.

Skipped instructions require x number of cycles to be skipped, where x equals the number of bytes in the skipped instruction opcode.

See the BYTES and CYCLES per INSTRUCTION table for details.

### Bytes and Cycles per Instruction

The following table shows the number of bytes and cycles for each instruction in the format of byte/cycle.

#### Arithmetic and Logic Instructions

	[B]	Direct	Immed.
ADD	1/1	3/4	2/2
ADC	1/1	3/4	2/2
SUBC	1/1	3/4	2/2
AND	1/1	3/4	2/2
OR	1/1	3/4	2/2
XOR	1/1	3/4	2/2
IFEQ	1/1	3/4	2/2
IFGT	1/1	3/4	2/2
IFBNE	1/1		
DRSZ		1/3	
SBIT	1/1	3/4	
RBIT	1/1	3/4	
IFBIT	1/1	3/4	

RPND	1/1
------	-----

#### Instructions Using A & C

CLRA	1/1
INCA	1/1
DECA	1/1
LAID	1/3
DCORA	1/1
RRCA	1/1
RLCA	1/1
SWAPA	1/1

SC	1/1
RC	1/1
IFC	1/1
IFNC	1/1
PUSHA	1/3
POPA	1/3
ANDSZ	2/2

**Transfer-of-Control Instructions**

JMPL	3/4
JMP	2/3
JP	1/3
JSRL	3/5
JSR	2/5
JSRB	2/5
JID	1/3
VIS	1/5
RET	1/5
RETSK	1/5
RETI	1/5
INTR	1/7
NOP	1/1

**Table 42. Memory Transfer Instructions**

	Register		Direct	Immed.	Register Indirect		
	Indirect				Auto Incr. & Decr.		
	[B]	[X]			[B+, B-]	[X+, X-]	
X A, <sup>(1)</sup>	1/1	1/3	2/3		1/2	1/3	
LD A, <sup>(1)</sup> (Note 11)	1/1	1/3	2/3	2/2	1/2	1/3	
LD B,Imm				1/1			(If B < 16)
LD B,Imm				2/2			(If B > 15)
LD Mem,Imm	2/2		3/3		2/2		
LD Reg,Imm			2/3				
IFEQ MD,Imm			3/3				

(1) => Memory location addressed by B or X or directly.

Table 43. OPCODE TABLE<sup>(1)</sup>

Upper Nibble																
F	E	D	C	B	A	9	8	7	6	5	4	3	2	1	0	
JP-15	JP-31	LD 0F0,#i	DRSZ 0F0	RRCA	RC	ADC A,#i	ADC A,[B]	IFBIT 0,[B]	ANDSZ A,#i	LD B,#0F	IFBNE 0	JSR x000–x0FF	JMP x000–x0FF	JP+17	INTR	0
JP-14	JP-30	LD 0F1,#i	DRSZ 0F1	*	SC	SUBC A,#i	SUBC A,[B]	IFBIT 1,[B]	JSRB	LD B,#0E	IFBNE 1	JSR x100–x1FF	JMP x100–x1FF	JP+18	JP+2	1
JP-13	JP-29	LD 0F2,#i	DRSZ 0F2	X A,[X+]	X A,[B+]	IFEQ A,#i	IFEQ A,[B]	IFBIT 2,[B]	Re-served	LD B,#0D	IFBNE 2	JSR x200–x2FF	JMP x200–x2FF	JP+19	JP+3	2
JP-12	JP-28	LD 0F3,#i	DRSZ 0F3	X A,[X-]	X A,[B-]	IFGT A,#i	IFGT A,[B]	IFBIT 3,[B]	Re-served	LD B,#0C	IFBNE 3	JSR x300–x3FF	JMP x300–x3FF	JP+20	JP+4	3
JP-11	JP-27	LD 0F4,#i	DRSZ 0F4	VIS	LAID	ADD A,#i	ADD A,[B]	IFBIT 4,[B]	CLRA	LD B,#0B	IFBNE 4	JSR x400–x4FF	JMP x400–x4FF	JP+21	JP+5	4
JP-10	JP-26	LD 0F5,#i	DRSZ 0F5	RPND	JID	AND A,#i	AND A,[B]	IFBIT 5,[B]	SWAPA	LD B,#0A	IFBNE 5	JSR x500–x5FF	JMP x500–x5FF	JP+22	JP+6	5
JP-9	JP-25	LD 0F6,#i	DRSZ 0F6	X A,[X]	X A,[B]	XOR A,#i	XOR A,[B]	IFBIT 6,[B]	DCORA	LD B,#09	IFBNE 6	JSR x600–x6FF	JMP x600–x6FF	JP+23	JP+7	6
JP-8	JP-24	LD 0F7,#i	DRSZ 0F7	*	*	OR A,#i	OR A,[B]	IFBIT 7,[B]	PUSHA	LD B,#08	IFBNE 7	JSR x700–x7FF	JMP x700–x7FF	JP+24	JP+8	7
JP-7	JP-23	LD 0F8,#i	DRSZ 0F8	NOP	RLCA	LD A,#i	IFC	SBIT 0,[B]	RBIT 0,[B]	LD B,#07	IFBNE 8	JSR x800–x8FF	JMP x800–x8FF	JP+25	JP+9	8
JP-6	JP-22	LD 0F9,#i	DRSZ 0F9	IFNE A,[B]	IFEQ Md,#i	IFNE A,#i	IFNC	SBIT 1,[B]	RBIT 1,[B]	LD B,#06	IFBNE 9	JSR x900–x9FF	JMP x900–x9FF	JP+26	JP+10	9
JP-5	JP-21	LD 0FA,#i	DRSZ 0FA	LD A,[X+]	LD A,[B+]	LD [B+],#i	INCA	SBIT 2,[B]	RBIT 2,[B]	LD B,#05	IFBNE 0A	JSR xA00–xAFF	JMP xA00–xAFF	JP+27	JP+11	A
JP-4	JP-20	LD 0FB,#i	DRSZ 0FB	LD A,[X-]	LD A,[B-]	LD [B-],#i	DECA	SBIT 3,[B]	RBIT 3,[B]	LD B,#04	IFBNE 0B	JSR xB00–xBFF	JMP xB00–xBFF	JP+28	JP+12	B
JP-3	JP-19	LD 0FC,#i	DRSZ 0FC	LD Md,#i	JMPL	X A,Md	POPA	SBIT 4,[B]	RBIT 4,[B]	LD B,#03	IFBNE 0C	JSR xC00–xCFF	JMP xC00–xCFF	JP+29	JP+13	C
JP-2	JP-18	LD 0FD,#i	DRSZ 0FD	DIR	JSRL	LD A,Md	RETSK	SBIT 5,[B]	RBIT 5,[B]	LD B,#02	IFBNE 0D	JSR xD00–xDFF	JMP xD00–xDFF	JP+30	JP+14	D
JP-1	JP-17	LD 0FE,#i	DRSZ 0FE	LD A,[X]	LD A,[B]	LD [B],#i	RET	SBIT 6,[B]	RBIT 6,[B]	LD B,#01	IFBNE 0E	JSR xE00–xEFF	JMP xE00–xEFF	JP+31	JP+15	E
JP-0	JP-16	LD 0FF,#i	DRSZ 0FF	*	*	LD B,#i	RETI	SBIT 7,[B]	RBIT 7,[B]	LD B,#00	IFBNE 0F	JSR xF00–xFF	JMP xF00–xFF	JP+32	JP+16	F

Lower Nibble

(1) \* is an unused opcode; i is the immediate data; Md is a directly addressed memory location; The opcode 60 Hex is also the opcode for IFBIT #i,A

## Development Support

### TOOLS ORDERING NUMBERS FOR THE COP8S/C/A FLASH FAMILY DEVICES

This section provides specific tools ordering information for the devices in this data sheet, followed by a summary of the tools and development kits available at print time. Up-to-date information, device selection guides, demos, updates, and purchase information can be obtained at our web site at: [www.ti.com](http://www.ti.com).

**Unless otherwise noted, tools can be purchased for worldwide delivery from TI's e-store:**

<http://www.ti.com/eStore>

Tool	Order Number	Cost*	Notes/Includes
<b>Evaluation Software and Reference Designs</b>			
Software and Utilities	Web Downloads: <a href="http://www.ti.com">www.ti.com</a>	Free	<b>Assembler/ Linker/ Simulators/ Library Manager/ Compiler Demos/ Flash ISP and NiceMon Debugger Utilities/ Example Code/ etc.</b> (Flash Emulator support requires licensed COP8-NSDEV CD-ROM).
Hardware Reference Designs	COP8-REF-FL1	VL	<b>For COP8Flash Sx/Cx</b> -Demo Board and Software; 44PLCC Socket; Stand-alone, or use as development target board with Flash ISP and/or COP8Flash Emulator. Does not include COP8 development software.
	COP8-REF-AM	VL	<b>For COP8Flash AME</b> - Demo Board and Software; 28DIP Socket. Stand alone, or use as development target board with Flash ISP and/or COP8Flash Emulator. Does not include COP8 development software.
<b>Starter Kits and Hardware Target Boards</b>			
Starter Development Kits	COP8-SKFLASH-01	VL	<b>Supports COP8Sx/Cx/AME</b> -Target board with 68PLCC COP8CDR9, 44PLCC and 28DIP sockets, LEDs, Test Points, and Breadboard Area. Development CD, ISP Cable, Debug Software and Source Code. No p/s. Also supports COP8Flash Emulators and Kanda ISP Tool.
	COP8-REF-FL1 or -AM	VL	COP8Flash Hardware Reference Design boards can also be used as Development Target boards, with ISP and Emulator onboard connectors.
<b>Software Development Languages, and Integrated Development Environments</b>			
TI's WCOP8 IDE and Assembler on CD	COP8-NSDEV	\$3	<b>Fully Licensed IDE with Assembler and Emulator/Debugger Support.</b> Assembler/ Linker/ Simulator/ Utilities/ Documentation. Updates from web. <b>Included with SKFlash, COP8 Emulators, COP8-PM.</b>
COP8 Library Manager from KKD	<a href="http://www.kkd.dk/libman.htm">www.kkd.dk/libman.htm</a>	Eval	<b>The ultimate information source for COP8 developers</b> - Integrates with WCOP8 IDE. Organize and manage code, notes, datasheets, etc.
WEBENCH Online Graphical Application Builder With Unis Processor Expert	<a href="http://www.ti.com/webench">www.ti.com/webench</a>	Free	<b>Online Graphical IDE, featuring UNIS Processor Expert( Code Development Tool with Simulator</b> -Develop applications, simulate and debug, download working code. Online project manager.
	COP8-SW-PE2	L	<b>Graphical IDE and Code Development Tool with Simulator</b> - Stand-alone, enhanced PC version of our WEBENCH tools on CD.
Byte Craft C Compiler	COP8-SW-COP8C COP8-SW-COP8CW	M H	DOS/16bit Version - No IDE. Win 32 Version with IDE.
IAR Embedded Workbench Tool Set.	COP8-SW-EWCOP8	H	Complete tool set, with COP8 Emulator/Debugger support. Baseline version - <b>Purchase from IAR only.</b> Assembler only; No COP8 Emulator/Debugger support.
	EWCOP8-BL Assembler-Only Version	Free	
<b>Hardware Emulation and Debug Tools</b>			
Hardware Emulators	COP8-EMFlash-00	L	Includes 110v/220v p/s, target cable with 2x7 connector, 68 pin COP8CDR9 Null Target, manuals and software on CD. - <b>COP8AME uses optional 28 pin Null Target (COP8-EMFA-28N).</b> - Add PLCC Target Package Adapter if needed.
	COP8-DMFlash-00	M	
	COP8-IMFlash-00	H	
Emulator Null Target	COP8-EMFA-68N COP8-EMFA-28N	VL VL	68 pin PLCC COP8CDR9; <b>Included in COP8-EM/DM/IM Flash.</b> 28pin DIP COP8AME9; <b>Must order separately.</b>

Emulator Target Package Adapters	COP8-EMFA-44P	VL	44 pin PLCC target package adapter. (Use instead of 2x7 emulator header)
	COP8-EMFA-68P	VL	68 pin PLCC target package adapter. (Use instead of 2x7 emulator header)
NiceMon Debug Monitor Utility	COP8-SW-NMON	Free	Download code and Monitor S/W for single-step debugging via Microwire. Includes PC control/debugger software and monitor program.
<b>Development and Production Programming Tools</b>			
TI's Approved Programmers	Third party programmers		Download a current list of approved third party programmers.
Programming Adapters (For any programmer supporting flash adapter base pinout)	COP8-PGMA-28DF1	L	For programming 28DIP COP8AME only.
	COP8-PGMA-28SF1	L	For programming 28SOIC COP8AME only.
	COP8-PGMA-44PF1	L	For programming all 44PLCC COP8FLASH.
	COP8-PGMA-44CSF	L	For programming all 44LLP COP8FLASH.
	COP8-PGMA-48TF1	L	For programming all 48TSSOP COP8 FLASH.
	COP8-PGMA-68PF1	L	For programming all 68PLCC COP8FLASH
KANDA's Flash ISP Programmer	COP8 USB ISP <a href="http://www.kanda.com">www.kanda.com</a>	L	USB connected Dongle, with target cable and Control Software; Updateable from the web; <b>Purchase from <a href="http://www.kanda.com">www.kanda.com</a></b>
	SofTec Micro ISP Programmer	inDart-COP8	Purchase from <a href="http://www.softecmicro.com">www.softecmicro.com</a>
Development Devices	COP8CBR9/CCR9/CDR9 COPCBE9/CCE9 COP8SBR/SCR9/SDR9 COP8SBE/SCE COP8AME9	Free	All packages. Obtain samples from: <a href="http://www.ti.com">www.ti.com</a>
<b>*Cost: Free; VL=&lt;\$100; L=\$100-\$300; M=\$300-\$1k; H=\$1k-\$3k; VH=\$3k-\$5k</b>			

## COP8 TOOLS OVERVIEW

<b>COP8 Evaluation Software and Reference Designs - Software and Hardware for: Evaluation of COP8 Development Environments; Learning about COP8 Architecture and Features; Demonstrating Application Specific Capabilities.</b>		
Product	Description	Source
WCOP8 IDE and Software Downloads	Software Evaluation downloads for Windows. Includes WCOP8 IDE evaluation version, Full COP8 Assembler/Linker, COP8-SIM Instruction Level Simulator or Unis Simulator, Byte Craft COP8C Compiler Demo, IAR Embedded Workbench (Assembler version), Manuals, Applications Software, and other COP8 technical information.	<a href="http://www.ti.com">www.ti.com</a> FREE Download
COP8 Hardware Reference Designs	Reference Designs for COP8 Families. Realtime hardware environments with a variety of functions for demonstrating the various capabilities and features of specific COP8 device families. Run Windows demo reference software, and exercise specific device capabilities. Also can be used as a realtime target board for code development, with our flash development tools. (Add our COP8Flash Emulator, or our COP8-NSDEV CD with your ISP cable for a complete low-cost development system.)	TI Distributor, or Order from: <a href="http://www.ti.com">www.ti.com</a>

<b>COP8 Starter Kits and Hardware Target Solutions - Hardware Kits for: In-depth Evaluation and Testing of COP8 capabilities; Developing and Testing Code; Implementing Target Design.</b>		
Product	Description	Source
COP8 Flash Starter Kits	Flash Starter Kit - A complete Code Development Tool for COP8Flash Families. A Windows IDE with Assembler, Simulator, and Debug Monitor (does not support COP8TAx devices), combined with a simple realtime target environment. Quickly design and simulate your code, then download to the target COP8flash device for execution and simple debugging. Includes a library of software routines, and source code. No power supply. (Add a COP8-EMFlash Emulator for advanced emulation and debugging)	TI Distributor, or Order from: <a href="http://www.ti.com">www.ti.com</a>
COP8 Hardware Reference Designs	Preconfigured realtime hardware environments with a variety of onboard I/O and display functions. Modify the reference software, or develop your own code. Boards support our COP8 ISP Utility, NiceMon Flash Debug Monitor, and our COP8Flash Emulators.	TI Distributor, or Order from: <a href="http://www.ti.com">www.ti.com</a>

COP8 Software Development Languages and Integrated Environments - Integrated Software for: Project Management; Code Development; Simulation and Debug.		
Product	Description	Source
WCOP8 IDE from TI on CD-ROM	TI's COP8 Software Development package for Windows on CD. Fully licensed versions of our WCOP8 IDE and Emulator Debugger, with Assembler/ Linker/ Simulators/ Library Manager/ Compiler Demos/ Flash ISP and NiceMon Debugger Utilities/ Example Code/ etc. Includes all COP8 datasheets and documentation. Included with most tools from TI.	TI Distributor, or Order from: <a href="http://www.ti.com">www.ti.com</a>
Unis Processor Expert	Processor Expert( from Unis Corporation - COP8 Code Generation and Simulation tool with Graphical and Traditional user interfaces. Automatically generates customized source code "Beans" (modules) containing working code for all on-chip features and peripherals, then integrates them into a fully functional application code design, with all documentation.	Unis, or Order from: <a href="http://www.ti.com">www.ti.com</a>
Byte Craft COP8C Compiler	ByteCraft COP8C- C Cross-Compiler and Code Development System. Includes BCLIDE (Integrated Development Environment) for Win32, editor, optimizing C Cross-Compiler, macro cross assembler, BC-Linker, and MetaLinktools support. (DOS/SUN versions available; Compiler is linkable under WCOP8 IDE)	ByteCraft Distributor, or Order from: <a href="http://www.ti.com">www.ti.com</a>
IAR Embedded Workbench	IAR EWCOP8 - ANSI C-Compiler and Embedded Workbench. A fully integrated Win32 IDE, ANSI C-Compiler, macro assembler, editor, linker, librarian, and C-Spy high-level simulator/debugger. (EWCOP8-M version includes COP8Flash Emulator support) (EWCOP8-BL version is limited to 4k code limit; no FP).	IAR Distributor, or Order from: <a href="http://www.ti.com">www.ti.com</a>

COP8 Hardware Emulation/Debug Tools - Hardware Tools for: Real-time Emulation; Target Hardware Debug; Target Design Test.		
Product	Description	Source
COP8Flash Emulators - COP8-EMFlash COP8-DMFlash COP8-IMFlash	COP8 In-Circuit Emulator for Flash Families. Windows based development and real-time in-circuit emulation tool, with trace (EM=None; DM/IM=32k), s/w breakpoints (DM=16, EM/IM=32K), source/symbolic debugger, and device programming. Includes COP8-NSDEV CD, 68pin Null Target, emulation cable with 2x7 connector, and power supply.	TI Distributor, or Order from: <a href="http://www.ti.com">www.ti.com</a>
NiceMon Debug Monitor Utility	A simple, single-step debug monitor with one breadpoint. MICROWIRE interface.	Download from: <a href="http://www.ti.com">www.ti.com</a>

Development and Production Programming Tools - Programmiers for: Design Development; Hardware Test; Pre-Production; Full Production.		
Product	Description	Source
COP8 Flash Emulators	COP8 Flash Emulators include in-circuit device programming capability during development.	TI Distributor, or Order from: <a href="http://www.ti.com">www.ti.com</a>
NiceMon Debugger, KANDAFash	TI's software Utilities "KANDAFash" and "NiceMon" provide development In-System-Programming for our Flash Starter Kit, our Prototype Development Board, or any other target board with appropriate connectors.	Download from: <a href="http://www.ti.com">www.ti.com</a>
KANDA COP8 USB ISP	The COP8 USB ISP programmer from KANDA is available for engineering, and small volume production use. USB interface.	<a href="http://www.kanda.com">www.kanda.com</a>
SofTec Micro inDart COP8	The inDart COP8 programmer from SofTec Micro is available for engineering and small volume production use. PC serial interface only.	<a href="http://www.softecmicro.com">www.softecmicro.com</a>
Third-Party Programmiers	Third-party programmiers and automatic handling equipment are approved for non-ISP engineering and production use.	Various Vendors
Factory Programming	Factory programming available for high-volume requirements.	TI Representative

**WHERE TO GET TOOLS**

Tools can be ordered directly from TI, TI's e-store (Worldwide delivery: <http://www.ti.com>) , a TI Distributor, or from the tool vendor. Go to the vendor's web site for current listings of distributors.

Vendor	Home Office	Electronic Sites	Other Main Offices
Byte Craft Limited	421 King Street North	<a href="http://www.bytecraft.com">www.bytecraft.com</a>	Distributors Worldwide
	Waterloo, Ontario	info@bytecraft.com	
	Canada N2J 4E4		
	Tel: 1-(519) 888-6911		
	Fax: (519) 746-6751		

Vendor	Home Office	Electronic Sites	Other Main Offices
IAR Systems AB	PO Box 23051	<a href="http://www.iar.se">www.iar.se</a>	USA:: San Francisco
	S-750 23 Uppsala	<a href="mailto:info@iar.se">info@iar.se</a>	Tel: +1-415-765-5500
	Sweden	<a href="mailto:info@iar.com">info@iar.com</a>	Fax: +1-415-765-5503
	Tel: +46 18 16 78 00	<a href="mailto:info@iarsys.co.uk">info@iarsys.co.uk</a>	UK: London
	Fax +46 18 16 78 38	<a href="mailto:info@iar.de">info@iar.de</a>	Tel: +44 171 924 33 34
			Fax: +44 171 924 53 41
			Germany: Munich
		Tel: +49 89 470 6022	
		Fax: +49 89 470 956	
Embedded Results LTD.	P.O. Box 200 Aberystwyth, SY23 2WD, UK Tel/Fax: +44 (0)8707 446 807	<a href="http://www.kanda.com">www.kanda.com</a> <a href="mailto:sales@kanda.com">sales@kanda.com</a> <a href="mailto:support@kanda.com">support@kanda.com</a>	USA: Tel/Fax: 800-510-3609 <a href="mailto:info@ucpros.com">info@ucpros.com</a> <a href="http://www.ucpros.com">www.ucpros.com</a>
K and K Development ApS	Kaergaardsvej 42 DK-8355 Solbjerg Denmark Fax: +45-8692-8500	<a href="http://www.kkd.dk">www.kkd.dk</a> <a href="mailto:kkd@kkd.dk">kkd@kkd.dk</a>	
TI Semiconductor	2900 Semiconductor Dr. Santa Clara, CA 95051 USA	<a href="http://www.ti.com">www.ti.com</a> <a href="mailto:support@nsc.com">support@nsc.com</a> <a href="mailto:europa.support@nsc.com">europa.support@nsc.com</a>	Europe: Tel: 49(0) 180 530 8585 Fax: 49(0) 180 530 8586
	Tel: 1-800-272-9959 Fax: 1-800-737-7018		Hong Kong: Distributors Worldwide
SofTec Microsystems	Via Roma, 1 33082 Azzano Decimo (PN) Italy Tel: +39 0434 640113 Fax: +39 0434 631598	<a href="mailto:info@softecmicro.com">info@softecmicro.com</a> <a href="http://www.softecmicro.com">www.softecmicro.com</a> <a href="mailto:support@softecmicro.com">support@softecmicro.com</a>	Germany: Tel.:+49 (0) 8761 63705 France: Tel: +33 (0) 562 072 954 UK: Tel: +44 (0) 1970 621033

The following companies have approved COP8 programmers in a variety of configurations. **Contact your vendor's local office or distributor and request a COP8FLASH update.** You can link to their web sites and get the latest listing of approved programmers at: [www.ti.com](http://www.ti.com).

Advantech; BP Microsystems; Data I/O; Dataman; Hi-Lo Systems; KANDA, Lloyd Research; MQP; Needhams; Phytion; SofTec Microsystems; System General; and Tribal Microsystems.

## REVISION HISTORY

Date	Section	Summary of Changes
January 2002	Forced Execution from Boot ROM.	Added Figure.
April 2002	Timers	Clarification on high speed PWM Timer use.
	Development Support	Updated with the latest support information.
February 2004	Pin Descriptions	Clarification of the functions of L4 and L6 for T2 and T3 PWM Output.
	Reset	Addition of caution regarding rising edge on RESET with low $V_{CC}$ .
	Power Saving Features	Description of modified function of ITMR Register.
	General	Deleted references to COP8ANE9, COP8SDE9 and COP8CFE9 devices which have been placed on Lifetime Buy. Removed temp range 7, $-40^{\circ}\text{C}$ to $+125^{\circ}\text{C}$
	Electrical Specifications	Updated A/D specifications to match production values Eliminated references to non-brownout devices. General update of electrical specifications.
	RESET	Eliminated references to non-brownout devices.
	Timers	Incorporated High Speed Timer/Port L interaction description from User Information Sheet
	Development Support	Additional update to current support.
March 2013	All	Changed layout of National Data Sheet to TI format.

**PACKAGING INFORMATION**

Orderable Device	Status (1)	Package Type	Package Drawing	Pins	Package Qty	Eco Plan (2)	Lead/Ball Finish	MSL Peak Temp (3)	Op Temp (°C)	Device Marking (4/5)	Samples
COP8AME9EMW8	OBSOLETE	SOIC	DW	28		TBD	Call TI	Call TI	-40 to 125	COP8AME9EMW8	
COP8AME9EMW8/NOPB	OBSOLETE	SOIC	DW	28		TBD	Call TI	Call TI	-40 to 125	COP8AME9EMW8	

(1) The marketing status values are defined as follows:

**ACTIVE:** Product device recommended for new designs.

**LIFEBUY:** TI has announced that the device will be discontinued, and a lifetime-buy period is in effect.

**NRND:** Not recommended for new designs. Device is in production to support existing customers, but TI does not recommend using this part in a new design.

**PREVIEW:** Device has been announced but is not in production. Samples may or may not be available.

**OBSOLETE:** TI has discontinued the production of the device.

(2) Eco Plan - The planned eco-friendly classification: Pb-Free (RoHS), Pb-Free (RoHS Exempt), or Green (RoHS & no Sb/Br) - please check <http://www.ti.com/productcontent> for the latest availability information and additional product content details.

**TBD:** The Pb-Free/Green conversion plan has not been defined.

**Pb-Free (RoHS):** TI's terms "Lead-Free" or "Pb-Free" mean semiconductor products that are compatible with the current RoHS requirements for all 6 substances, including the requirement that lead not exceed 0.1% by weight in homogeneous materials. Where designed to be soldered at high temperatures, TI Pb-Free products are suitable for use in specified lead-free processes.

**Pb-Free (RoHS Exempt):** This component has a RoHS exemption for either 1) lead-based flip-chip solder bumps used between the die and package, or 2) lead-based die adhesive used between the die and leadframe. The component is otherwise considered Pb-Free (RoHS compatible) as defined above.

**Green (RoHS & no Sb/Br):** TI defines "Green" to mean Pb-Free (RoHS compatible), and free of Bromine (Br) and Antimony (Sb) based flame retardants (Br or Sb do not exceed 0.1% by weight in homogeneous material)

(3) MSL, Peak Temp. -- The Moisture Sensitivity Level rating according to the JEDEC industry standard classifications, and peak solder temperature.

(4) There may be additional marking, which relates to the logo, the lot trace code information, or the environmental category on the device.

(5) Multiple Device Markings will be inside parentheses. Only one Device Marking contained in parentheses and separated by a "~" will appear on a device. If a line is indented then it is a continuation of the previous line and the two combined represent the entire Device Marking for that device.

**Important Information and Disclaimer:** The information provided on this page represents TI's knowledge and belief as of the date that it is provided. TI bases its knowledge and belief on information provided by third parties, and makes no representation or warranty as to the accuracy of such information. Efforts are underway to better integrate information from third parties. TI has taken and continues to take reasonable steps to provide representative and accurate information but may not have conducted destructive testing or chemical analysis on incoming materials and chemicals. TI and TI suppliers consider certain information to be proprietary, and thus CAS numbers and other limited information may not be available for release.

In no event shall TI's liability arising out of such information exceed the total purchase price of the TI part(s) at issue in this document sold by TI to Customer on an annual basis.

DW (R-PDSO-G28)

PLASTIC SMALL OUTLINE

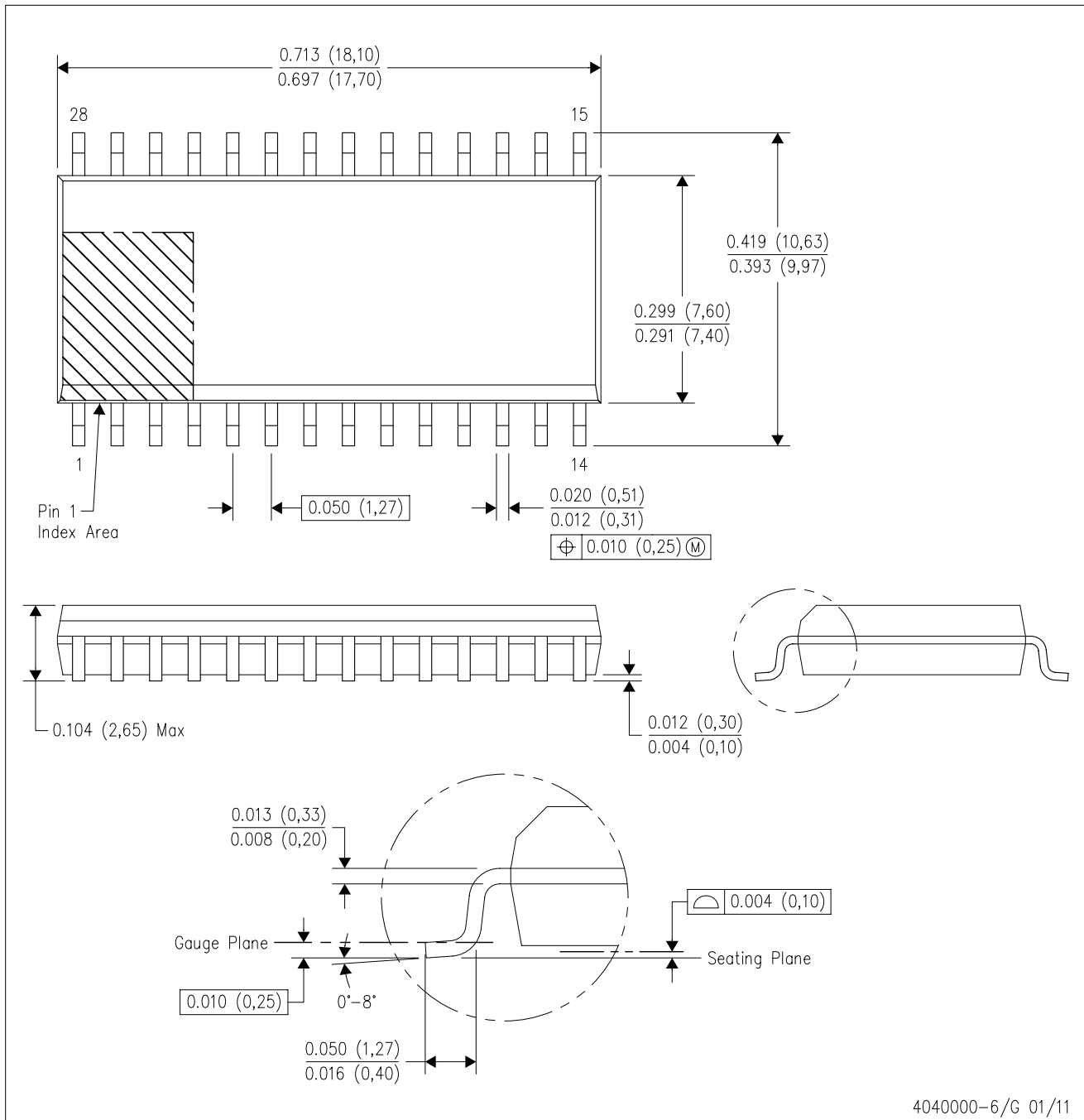

4040000-6/G 01/11

- NOTES:
- All linear dimensions are in inches (millimeters). Dimensioning and tolerancing per ASME Y14.5M-1994.
  - This drawing is subject to change without notice.
  - Body dimensions do not include mold flash or protrusion not to exceed 0.006 (0,15).
  - Falls within JEDEC MS-013 variation AE.

## IMPORTANT NOTICE

Texas Instruments Incorporated and its subsidiaries (TI) reserve the right to make corrections, enhancements, improvements and other changes to its semiconductor products and services per JESD46, latest issue, and to discontinue any product or service per JESD48, latest issue. Buyers should obtain the latest relevant information before placing orders and should verify that such information is current and complete. All semiconductor products (also referred to herein as "components") are sold subject to TI's terms and conditions of sale supplied at the time of order acknowledgment.

TI warrants performance of its components to the specifications applicable at the time of sale, in accordance with the warranty in TI's terms and conditions of sale of semiconductor products. Testing and other quality control techniques are used to the extent TI deems necessary to support this warranty. Except where mandated by applicable law, testing of all parameters of each component is not necessarily performed.

TI assumes no liability for applications assistance or the design of Buyers' products. Buyers are responsible for their products and applications using TI components. To minimize the risks associated with Buyers' products and applications, Buyers should provide adequate design and operating safeguards.

TI does not warrant or represent that any license, either express or implied, is granted under any patent right, copyright, mask work right, or other intellectual property right relating to any combination, machine, or process in which TI components or services are used. Information published by TI regarding third-party products or services does not constitute a license to use such products or services or a warranty or endorsement thereof. Use of such information may require a license from a third party under the patents or other intellectual property of the third party, or a license from TI under the patents or other intellectual property of TI.

Reproduction of significant portions of TI information in TI data books or data sheets is permissible only if reproduction is without alteration and is accompanied by all associated warranties, conditions, limitations, and notices. TI is not responsible or liable for such altered documentation. Information of third parties may be subject to additional restrictions.

Resale of TI components or services with statements different from or beyond the parameters stated by TI for that component or service voids all express and any implied warranties for the associated TI component or service and is an unfair and deceptive business practice. TI is not responsible or liable for any such statements.

Buyer acknowledges and agrees that it is solely responsible for compliance with all legal, regulatory and safety-related requirements concerning its products, and any use of TI components in its applications, notwithstanding any applications-related information or support that may be provided by TI. Buyer represents and agrees that it has all the necessary expertise to create and implement safeguards which anticipate dangerous consequences of failures, monitor failures and their consequences, lessen the likelihood of failures that might cause harm and take appropriate remedial actions. Buyer will fully indemnify TI and its representatives against any damages arising out of the use of any TI components in safety-critical applications.

In some cases, TI components may be promoted specifically to facilitate safety-related applications. With such components, TI's goal is to help enable customers to design and create their own end-product solutions that meet applicable functional safety standards and requirements. Nonetheless, such components are subject to these terms.

No TI components are authorized for use in FDA Class III (or similar life-critical medical equipment) unless authorized officers of the parties have executed a special agreement specifically governing such use.

Only those TI components which TI has specifically designated as military grade or "enhanced plastic" are designed and intended for use in military/aerospace applications or environments. Buyer acknowledges and agrees that any military or aerospace use of TI components which have **not** been so designated is solely at the Buyer's risk, and that Buyer is solely responsible for compliance with all legal and regulatory requirements in connection with such use.

TI has specifically designated certain components as meeting ISO/TS16949 requirements, mainly for automotive use. In any case of use of non-designated products, TI will not be responsible for any failure to meet ISO/TS16949.

### Products

Audio	<a href="http://www.ti.com/audio">www.ti.com/audio</a>
Amplifiers	<a href="http://amplifier.ti.com">amplifier.ti.com</a>
Data Converters	<a href="http://dataconverter.ti.com">dataconverter.ti.com</a>
DLP® Products	<a href="http://www.dlp.com">www.dlp.com</a>
DSP	<a href="http://dsp.ti.com">dsp.ti.com</a>
Clocks and Timers	<a href="http://www.ti.com/clocks">www.ti.com/clocks</a>
Interface	<a href="http://interface.ti.com">interface.ti.com</a>
Logic	<a href="http://logic.ti.com">logic.ti.com</a>
Power Mgmt	<a href="http://power.ti.com">power.ti.com</a>
Microcontrollers	<a href="http://microcontroller.ti.com">microcontroller.ti.com</a>
RFID	<a href="http://www.ti-rfid.com">www.ti-rfid.com</a>
OMAP Applications Processors	<a href="http://www.ti.com/omap">www.ti.com/omap</a>
Wireless Connectivity	<a href="http://www.ti.com/wirelessconnectivity">www.ti.com/wirelessconnectivity</a>

### Applications

Automotive and Transportation	<a href="http://www.ti.com/automotive">www.ti.com/automotive</a>
Communications and Telecom	<a href="http://www.ti.com/communications">www.ti.com/communications</a>
Computers and Peripherals	<a href="http://www.ti.com/computers">www.ti.com/computers</a>
Consumer Electronics	<a href="http://www.ti.com/consumer-apps">www.ti.com/consumer-apps</a>
Energy and Lighting	<a href="http://www.ti.com/energy">www.ti.com/energy</a>
Industrial	<a href="http://www.ti.com/industrial">www.ti.com/industrial</a>
Medical	<a href="http://www.ti.com/medical">www.ti.com/medical</a>
Security	<a href="http://www.ti.com/security">www.ti.com/security</a>
Space, Avionics and Defense	<a href="http://www.ti.com/space-avionics-defense">www.ti.com/space-avionics-defense</a>
Video and Imaging	<a href="http://www.ti.com/video">www.ti.com/video</a>

### TI E2E Community

[e2e.ti.com](http://e2e.ti.com)

## Looking for pricing, stock, or lifecycle information?

Click below to explore more details on WIN SOURCE:

- ⊖ [View COP8AME9EMW8/NOPB on WIN SOURCE](#)
- ⊖ [Texas Instruments](#) Information

## Optimize Your Supply Chain with WIN SOURCE Solutions

- ✓ Global Sourcing Solution
- ✓ Obsolete Management
- ✓ Cost Control Management
- ✓ Shortage Management
- ✓ Alternative Solution
- ✓ Excess Inventory Management