

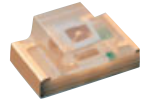

**THE DATASHEET OF
UG1112H-TR**





Absolute Maximum Ratings

Ta = 25°C

		Blue	Blue Green	Green	Yellow	Red	Units
		UB	UC	UG	UY	UR	
Power Dissipation	Pd	78	78	78	87	87	mW
Forward Current	IF	20	20	20	30	30	mA
Peak Forward Current	IFM	48	48	48	100	100	mA
Reverse Voltage	VR	5	5	5	5	5	V
Operating Temp.	Topr	-40~+85	-40~+85	-40~+85	-40~+85	-40~+85	°C
Storage Temp.	Tstg	-40~+100	-40~+100	-40~+100	-40~+100	-40~+100	°C
Derating *	ΔIF	0.28	0.28	0.28	0.43	0.43	mA/°C

* The current derating for operation applies when temperature is above 25°C.

• IFM Condition : tw ≤ 1ms, Duty ≤ 1/20 (UY, UR : Duty ≤ 1/10)

Electro-Optical Characteristics

Ta = 25°C

Part No.	Chip		Lens Color	Luminous Intensity				Wavelength				Forward Voltage			Reverse Current	
	Material	Emitted Color		Iv			λ d	λ p		Δλ		VF			IR	
				MIN	TYP	IF	TYP	TYP	IF	TYP	MAX	IF	MAX	VR		
UB1112H	InGaN	Blue	Milky White	17	34	10	470	465	26	10	3.4	3.9	10	100	5	
UC1112H	InGaN	Blue Green		80	160	10	508	502	30	10	3.4	3.9	10	100	5	
UG1112H	InGaN	Green		96	160	10	530	522	35	10	3.4	3.9	10	100	5	
UY1112H	AlGaInP	Yellow		50	100	20	590	592	18	20	2.2	2.8	20	100	5	
UR1112H	AlGaInP	Red		50	100	20	630	641	18	20	2.2	2.8	20	100	5	
Units			mcd	mcd	mA	nm	nm	nm	mA	V	V	mA	μA	V		

Package Dimensions

Unit : mm

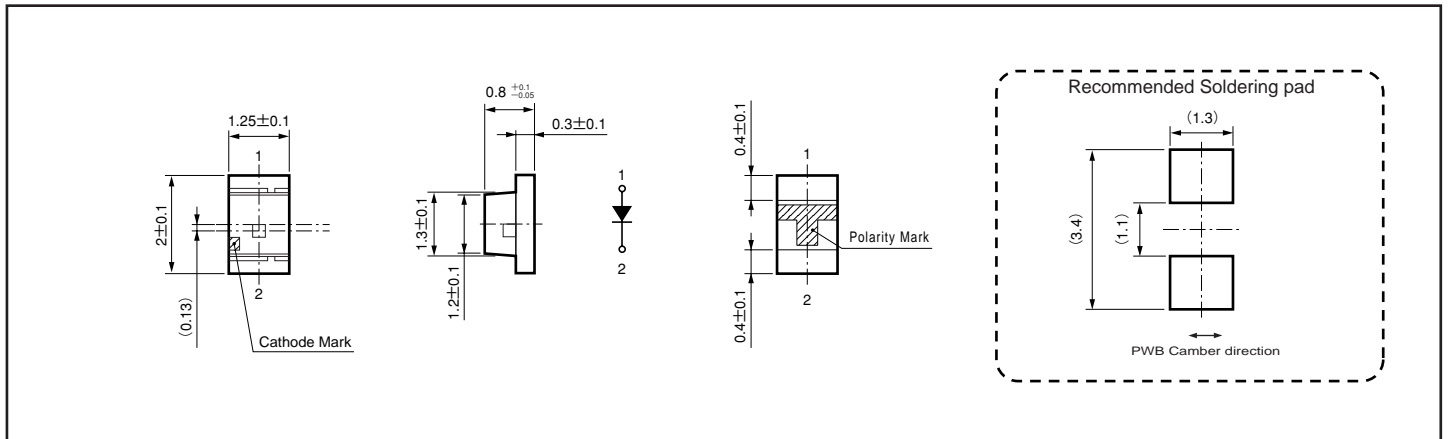

Spatial Distribution

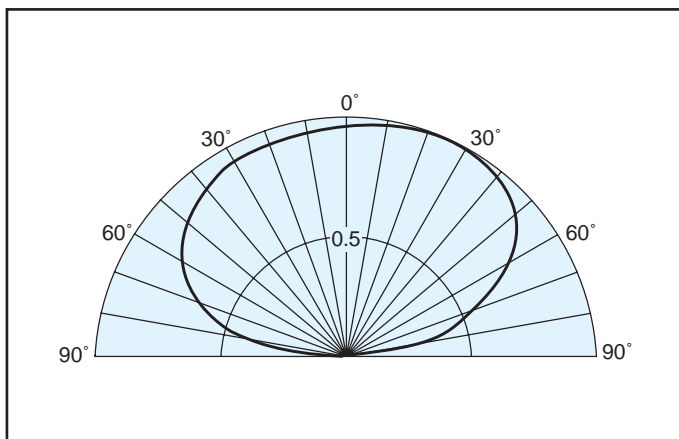

Taping Specification

Unit : mm

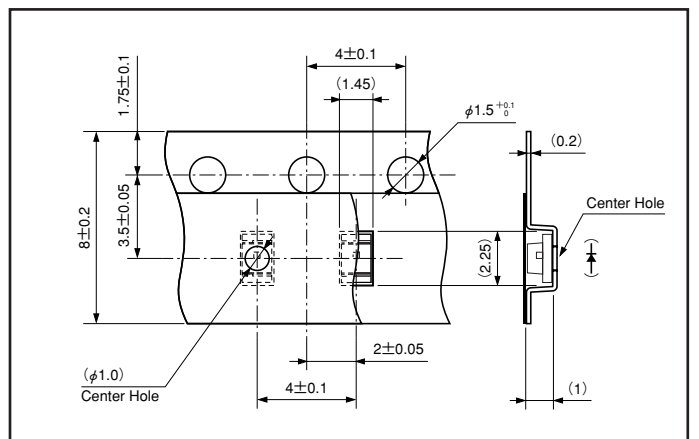

* Quantity 4,000 pcs/Reel

■ Power Dissipation vs. Ambient Temperature

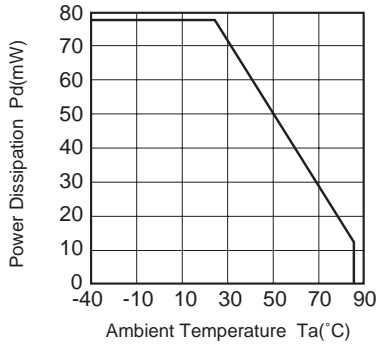

■ Ambient Temperature vs. Maximum Forward Current

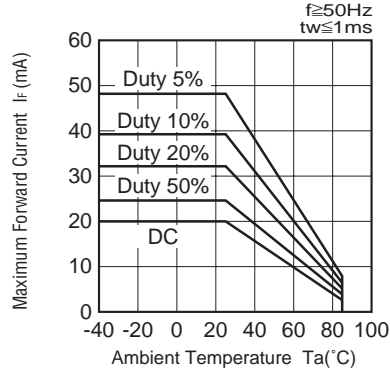

■ Pulse Duration vs. Maximum Tolerable Peak Current

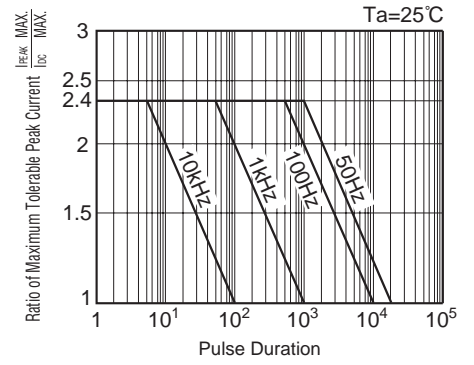

■ Forward Voltage vs. Forward Current

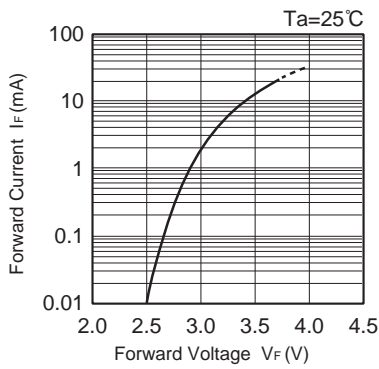

■ Forward Current vs. Relative Intensity

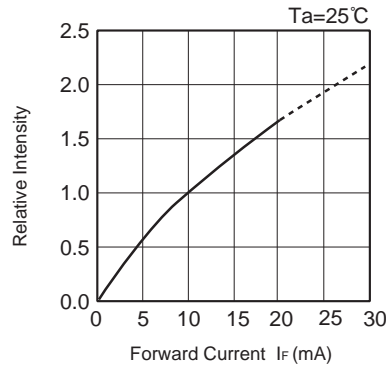

■ Ambient Temperature vs. Relative Intensity

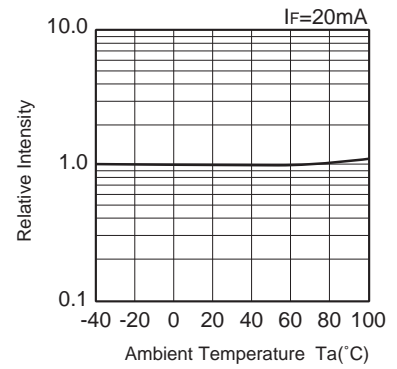

■ Spectral Distribution

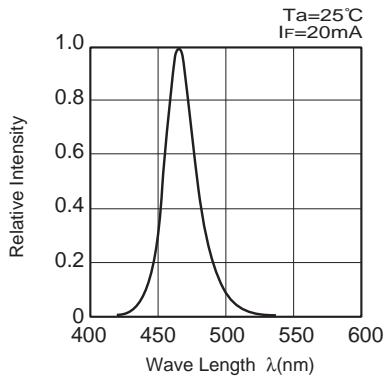

■ Power Dissipation vs. Ambient Temperature

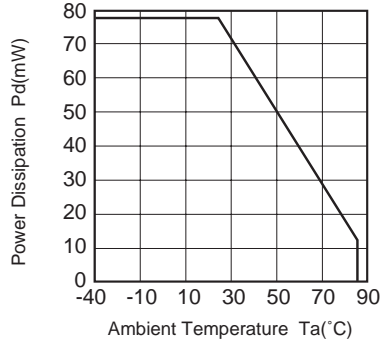

■ Ambient Temperature vs. Maximum Forward Current

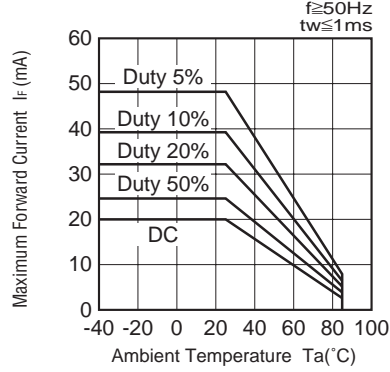

■ Pulse Duration vs. Maximum Tolerable Peak Current

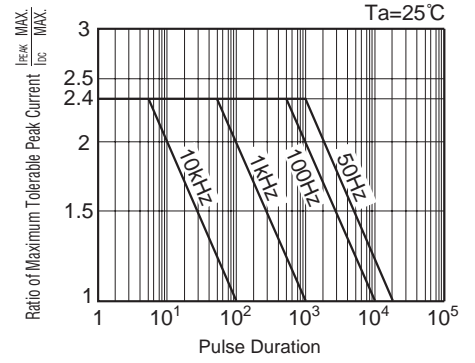

■ Forward Voltage vs. Forward Current

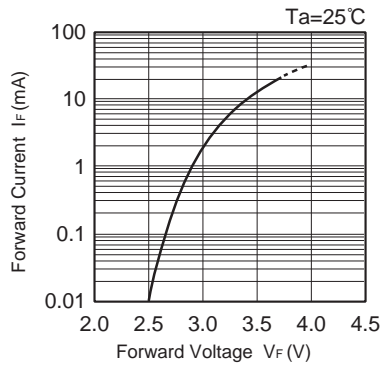

■ Forward Current vs. Relative Intensity

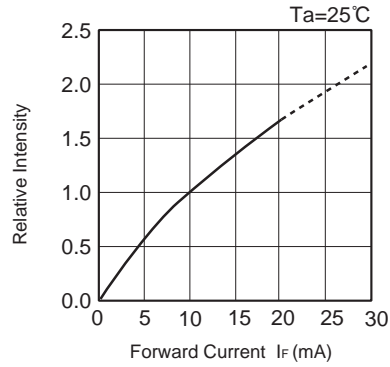

■ Ambient Temperature vs. Relative Intensity

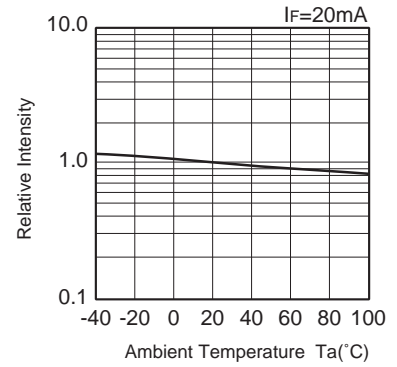

■ Spectral Distribution

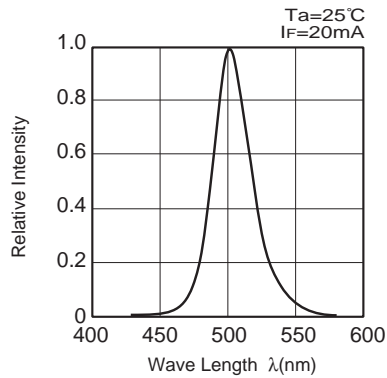



ULTRA HIGH BRIGHTNESS TYPE SURFACE MOUNT LED

UY1112H

Power Dissipation vs. Ambient Temperature

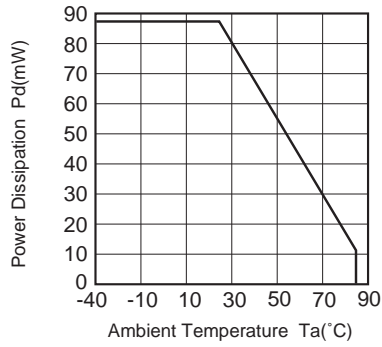

Ambient Temperature vs. Maximum Forward Current

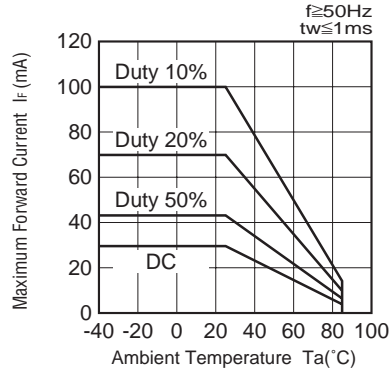

Pulse Duration vs. Maximum Tolerable Peak Current

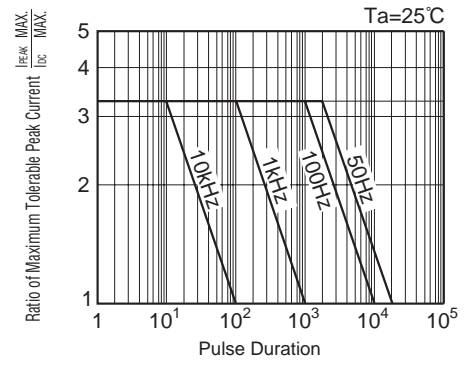

Forward Voltage vs. Forward Current

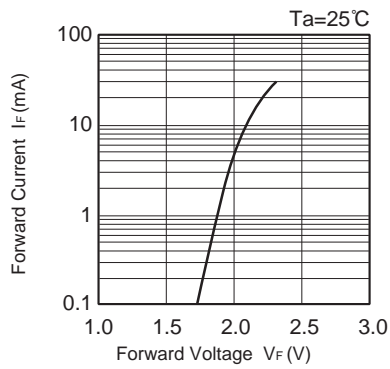

Forward Current vs. Relative Intensity

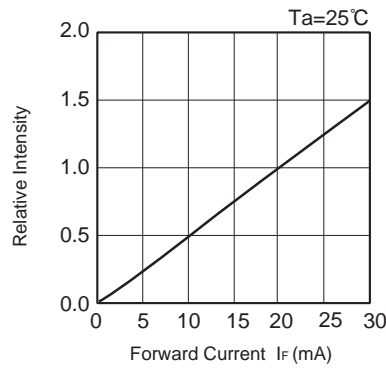

Ambient Temperature vs. Relative Intensity

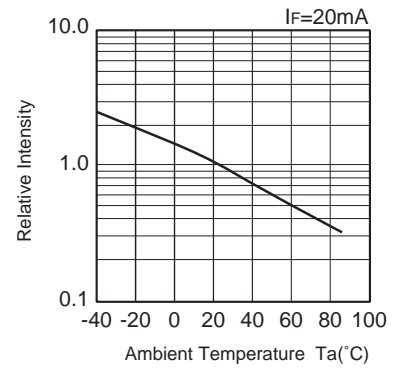

Spectral Distribution

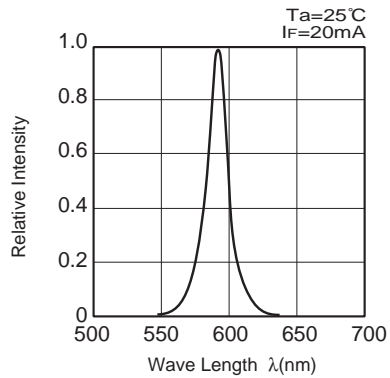

Looking for pricing, stock, or lifecycle information?

Click below to explore more details on WIN SOURCE:

-  [View UG1112H-TR on WIN SOURCE](#)
-  [Stanley Electric Co Information](#)

Optimize Your Supply Chain with WIN SOURCE Solutions

-  Global Sourcing Solution
-  Obsolete Management
-  Cost Control Management
-  Shortage Management
-  Alternative Solution
-  Excess Inventory Management