



**THE DATASHEET OF
2M801-009-01M10-201PA**



About Amphenol Aerospace

Your Source for Interconnect Products



Amphenol Aerospace

Contact Us:

Amphenol Aerospace
40-60 Delaware Avenue
Sidney, NY 13838-1395

Customer Service:

Mon - Fri 8AM - 5PM
Phone: (800) 678-0141
Fax: (607) 563-5157

Online: www.amphenol-aerospace.com



*Amphenol Aerospace, Amphenol Commercial Air,
and Amphenol Industrial Operations Main Facility in Sidney, NY USA*

About Amphenol Aerospace:

Amphenol Aerospace, a Division of Amphenol Corporation, is one of the largest manufacturers of interconnect products in the world for the Military, Commercial Aerospace and Industrial markets. Amphenol designs, manufactures and markets circular and rectangular, electronic, fiber optic, EMI/EMP filter, and a variety of special applications connectors and interconnect systems.

Our state-of-the-art facility is nestled at the foothills of the Catskill Mountains in Sidney, NY. The Amphenol complex houses many technologies including CNC machining, die-casting, molding, impact and extruding, plating, screw machining and process controls. Our fully equipped material evaluation lab and engineering organization utilize the latest in computer aided design software and analysis tools, allowing us to design, test, and qualify advanced interconnect systems. Amphenol's interconnect products are supplied to thousands of OEMs worldwide and are supported by our worldwide sales and engineering force, including the largest global network of electronic distributors.



Customer-Centric:

Our #1 priority is our customers who deserve quality product on time.

Accountable:

Clear owners, clear actions, clear results.

Reliable:

What we build matters and quality is imperative.

Enthusiastic:

Challenges create rewarding opportunities. Enthusiasm is contagious and we will spread it.

Quality Assurance:

Amphenol Aerospace has been awarded both AS9100 - Revision C and ISO9001:2008 Quality Assurance Certifications.

Micro38999 Reference Guide

A TECHNICAL REFERENCE

| | |
|--------------------------------|-------|
| 2M Series Selection Table | 3 |
| Size & Weight Comparison Chart | 4, 5 |
| Insert Arrangements | 6-9 |
| Straight PCB Footprints | 10-20 |

B PERFORMANCE SPEC

| | | |
|--------------------|----------------|-------|
| Materials Finishes | Specifications | 21-27 |
|--------------------|----------------|-------|

C 2M805

| | | |
|----------------------------|--------------------------------|----|
| Specs/ Info | 2M805 Overview | 28 |
| How to Order | Plugs & Receptacles | 29 |
| How to Order | High Speed Plugs & Receptacles | 30 |
| Weight | Connector Weight | 31 |
| Plug | 2M805-001, 002 | 32 |
| In-Line Receptacle | 2M805-003-01, 004-01 | 33 |
| Square Flange Receptacle | 2M805-003-02, 004-02 | 34 |
| Jam Nut | 2M805-003-07, 004-07 | 35 |
| PCB Solder Cup Sq Flange | 2M805-005-02, 017-02 | 36 |
| PCB Solder Cup Jam Nut | 2M805-005-07, 017-07 | 37 |
| PCB Standoff Double Flange | 2M805-067-07 | 38 |
| How to Order | Protection Caps | 39 |
| Protection Cap | 2M667-261, 262 | 40 |

D 2M804

| | | |
|----------------------------|----------------------|----|
| Specs/ Info | 2M804 Overview | 41 |
| How to Order | Plugs & Receptacles | 42 |
| Weight | Connector Weight | 43 |
| Plug | 2M804-001-06, 002-06 | 44 |
| Jam Nut Rear Panel | 2M804-003-07, 004-07 | 45 |
| Jam Nut Front Panel | 2M804-003-00, 004-00 | 46 |
| In-Line Receptacle | 2M804-003-01, 004-01 | 47 |
| PCB Solder Rear Jam Nut | 2M804-005-07, 020-07 | 48 |
| PCB Solder Cup Recept | 2M804-005-00, 020-00 | 49 |
| Jam Nut Panel Mount Plug | 2M804-009-07, 021-07 | 50 |
| Jam Nut Front Panel Plug | 2M804-009-00, 021-00 | 51 |
| Flange Panel Mount Plug | 2M804-009-02, 021-02 | 52 |
| PCB Standoff Double Flange | 2M804-025-07 | 53 |
| How to Order Protect Caps | 2M667-202 | 54 |
| How to Order Protect Caps | 2M809-198 | 55 |
| Protection Caps | 2M809-198, 2M667-202 | 56 |
| How to Order Plug Rubber | 2M809-083, 087 | 57 |
| Plug Rubber Caps | 2M809-083, 087 | 58 |

E 2M803

| | | |
|---------------------------|----------------------|----|
| Specs/ Info | 2M803 Overview | 59 |
| How to Order | Plugs & Receptacles | 60 |
| Weight | Connector Weight | 61 |
| Plug | 2M803-001-06, 002-06 | 62 |
| Jam Nut | 2M803-003-70, 004-07 | 63 |
| Flange Mount | 2M803-003-02, 004-02 | 64 |
| In-Line Recept | 2M803-003-01, 004-01 | 65 |
| PCB Flange Mt Jam Nut | 2M803-005-02, 07 | 66 |
| How to Order Protect Caps | 2M660-082, 083 | 67 |
| Protection Caps | 2M660-082, 083 | 68 |

F 2M801

| | | |
|----------------------------|--------------------------------|----|
| Specs/ Info | 2M801 Overview | 69 |
| How to Order | Plugs & Receptacles | 70 |
| How to Order | High Speed Plugs & Receptacles | 71 |
| Weight | Connector Weight | 72 |
| Plug | 2M801-007, 008 | 73 |
| Jam Nut | 2M801-009-07, 010-07 | 74 |
| Square Flange | 2M801-009-02, 010-02 | 75 |
| In-Line Recept | 2M801-009-01, 010-01 | 76 |
| PCB Flange Mt & Jam Nut | 2M801-011, 033 | 77 |
| PCB Right Angle Jam Nut | 2M801-023-07 | 78 |
| PCB Standoff Double Flange | 2M801-033-07 | 79 |
| How to Order Protect Caps | 2M667-217, 218 | 80 |
| Protection Caps | 2M660-082 | 81 |
| Protection Caps | 2M660-083 | 82 |

G HERMETIC

| | | |
|-----------------------|------------------|----|
| Specs/ Info Hermetic | Overview | 83 |
| How to Order 2M805 | 2M805-006 | 84 |
| Flange Mount | 2M805-006-02 | 85 |
| Solder Mount | 2M805-006-03 | 86 |
| Jam Nut | 2M805-006-07 | 87 |
| How to Order 2M804 | 2M804-006 | 88 |
| Jam Nut | 2M804-006-07 | 89 |
| Front Panel Jam Nut | 2M804-006-00 | 90 |
| How to Order 2M803 | 2M803-006 | 91 |
| Flange Mount/ Jam Nut | 2M803-006-02, 07 | 92 |
| How to Order 2M801 | 2M801-012 | 93 |
| Jam Nut | 2M801-012-07 | 94 |
| Square Flange | 2M801-012-02 | 95 |
| Weld Mount | 2M801-012-03 | 96 |

H FILTER

| | | |
|-----------------------------|----------|----|
| Advantages | Overview | 97 |
| Attenuation Characteristics | | 98 |

J ACCESSORIES

| | | |
|------------------------------|---------------------------|----------|
| Accessories, Contacts, Tools | Table of Content | 99 |
| Contact/Tools | Torque Values | 100 |
| Assembly Instructions | 2M Series | 101, 102 |
| Sealing Plugs/ Tools | Grommet, Spanner, Holding | 103, 104 |
| Strain Relief Clamp | 2M620MS064, 065 | 105, 106 |
| Micro Band Adapter | Thread/ Low Profile | 107, 110 |
| Environmental Backshells | | 111-112 |
| EMI Backshells | | 113-117 |
| Shorting Cap Backshell | | 118, 119 |
| Shrink Boot | 2M809S06, 2M809A060 | 120, 121 |
| Hex Jam Nuts | 2M809-035 | 122 |
| Flange Gaskets | 2M809-106 | 123, 124 |
| O-Ring | 2M809-109 | 125 |

2M Series Selection Table

2M801, 2M803, 2M804 and 2M805



| SERIES | 2M805 | 2M804 | 2M803 | 2M801 |
|------------------------|---|--|---|---|
| Pages | Pages 28-39 | Pages 40-57 | Pages 58-67 | Page 68-80 |
| TYPE | Tri-Start ACME Thread | Push-Pull | Bayonet | Dual-Start ACME Thread |
| DESCRIPTION | "Anti-Decoupling" ratchet mechanism and ground spring for military airframes and avionics boxes. Fast mating. | Breakaway connector for headsets and tactical equipment. Gold-plated spring for long mating life and superior EMI shielding. | Quick-mating, light duty, general purpose. Not rated for immersion, 50 milliohms shell-to-shell resistance. | More rugged keys and threads. Faster mating. |
| CONTACTS | 1 to 130 | 1 to 85 | 1 to 55 | 1 to 130 |
| COUPLING | Tri-Start Thread | Push, Pull Quick-Disconnect | 1/4 turn lock Bayonet | Threaded Coupling with 1 1/2 Turns to Full Mate |
| WATER IMMERSION, MATED | MIL-STD-810 Method 512 1 Meter for 1 Hour | MIL-STD-810 Method 512 1 Meter for 1 Hour | Splashproof | MIL-STD-810 Method 512 1 Meter for 1 Hour |
| EMI SHIELDING | Excellent | Excellent | Fair | Very Good |
| VIBRATION AND SHOCK | 43.9 g's Random Vibration, Sine Vibration 60 g; 300 g's Shock | 37 g's Random Vibration; 300 g's Shock | 37 g's Random Vibration; 300 g's Shock | 43.9 g's Random Vibration, Sine Vibration 60 g; 300 g's Shock |
| MATING CYCLES | 500 Cycles | 2000 Cycles | 1000 Cycles Aluminum 2000 Cycles Stainless Steel | 2000 Cycles (-16 Plugs) 500 Cycles (-26 Plugs) |
| ELECTRICAL PERFORMANCE | #12: 23 AMP, 1800 VAC #16: 13 AMP, 1800 VAC #20: 7.5 AMP, 1000 VAC #23: 5 AMP, 750 VAC | #12: 23 AMP, 1800 VAC #16: 13 AMP, 1800 VAC #20: 7.5 AMP, 1000 VAC #23: 5 AMP, 750 VAC | #12: 23 AMP, 1800 VAC #16: 13 AMP, 1800 VAC #20: 7.5 AMP, 1000 VAC #23: 5 AMP, 750 VAC | #12: 23 AMP, 1800 VAC #16: 13 AMP, 1800 VAC #20: 7.5 AMP, 1000 VAC #23: 5 AMP, 750 VAC |
| FILTERED | See pages 95, 96 | See pages 95, 96 | See pages 95, 96 | See pages 95, 96 |

Size & Weight Comparison Charts

2M805 VS. D38999 Series III



2M805 Series

Weight Comparison: 2M805 VS. D38999 Series III

| 2M805 Layout | Number of Contacts | D38999 Layout | Number of Contacts | 2M805 Weight | D38999 Aluminum | % Weight Savings | D38999 Composite | % Weight Savings |
|--------------|--------------------|---------------|--------------------|--------------|-----------------|------------------|------------------|------------------|
| 8-7 | 7 #23 | 9-35 | 6 #20 | 13.4 | 26.3 | 49% | 19.9 | 33% |
| 10-13 | 13 #23 | 11-35 | 13 #22D | 23.0 | 35.7 | 36% | 26.8 | 14% |
| 11-19 | 19 #23 | 13-35 | 19 #22D | 26.4 | 50.7 | 48% | 38.5 | 31% |
| 12-26 | 26 #23 | 17-26 | 26 #20 | 29.4 | 58.5 | 50% | 62.6 | 53% |
| 15-37 | 37 #23 | 15-35 | 37 #22D | 42.7 | 72.1 | 41% | 57.4 | 26% |
| 18-55 | 55 #23 | 17-35 | 55 #22D | 59.6 | 81.6 | 27% | 65.6 | 9% |
| 19-85 | 85 #23 | 21-35 | 85 #22D | 59.8 | 119.7 | 50% | 99.1 | 40% |
| 23-130 | 130 #23 | 25-35 | 128 #22D | 85.5 | 159.3 | 46% | 136.6 | 37% |

Size Comparison: 2M805 VS. D38999 Series III

| 2M805 Layout | Maximum Plug Diameter | | | | | Maximum Jam Nut Receptacle Diameter | | | | |
|--------------|-----------------------|-------|--------|-------|-------------|-------------------------------------|-------|--------|-------|-------------|
| | 2M805 | | D38999 | | % Reduction | 2M805 | | D38999 | | % Reduction |
| | In. | mm. | In. | mm. | | In. | mm. | In. | mm. | |
| 8-7 | .707 | 17.96 | .859 | 21.81 | 17% | .775 | 19.69 | 1.201 | 30.51 | 35% |
| 10-13 | .804 | 20.42 | .969 | 24.61 | 18% | .895 | 22.73 | 1.386 | 30.50 | 35% |
| 11-19 | .933 | 23.70 | 1.141 | 28.98 | 20% | .960 | 24.38 | 1.512 | 38.40 | 36% |
| 12-26 | .999 | 25.37 | 1.391 | 35.33 | 29% | 1.075 | 27.31 | 1.764 | 44.81 | 39% |
| 15-37 | 1.113 | 28.27 | 1.266 | 32.16 | 13% | 1.218 | 30.86 | 1.638 | 41.61 | 26% |
| 18-55 | 1.308 | 33.02 | 1.391 | 35.33 | 7% | 1.404 | 35.66 | 1.764 | 44.81 | 20% |
| 19-85 | 1.328 | 33.73 | 1.625 | 41.27 | 19% | 1.465 | 37.21 | 2.075 | 52.71 | 29% |
| 23-130 | 1.577 | 40.06 | 1.875 | 47.63 | 16% | 1.720 | 43.69 | 2.323 | 59.00 | 26% |

Note: Weights shown include contacts and represent a mated pair of plug and jam nut receptacle. Weights are in grams.

Size & Weight Comparison Charts

2M801 VS. D38999 Series III



2M801 Series

Weight Comparison: 2M801 VS. D38999 Series III

| 2M801 Layout | Number of Contacts | D38999 Layout | Number of Contacts | 2M801 Weight | D38999 Aluminum | % Weight Savings | D38999 Composite | % Weight Savings |
|--------------|--------------------|---------------|--------------------|--------------|-----------------|------------------|------------------|------------------|
| 5-3 | 3 | 9-98 | 3 | 7.9 | 25.3 | 69% | 19.9 | 60% |
| 6-7 | 7 | 9-35 | 6 | 9.8 | 26.3 | 63% | 19.9 | 51% |
| 9-19 | 19 | 13-35 | 22 | 18.8 | 50.7 | 63% | 38.5 | 51% |
| 13-37 | 37 | 15-35 | 37 | 36.0 | 72.1 | 50% | 57.4 | 37% |
| 16-55 | 55 | 17-35 | 55 | 49.8 | 81.6 | 39% | 65.6 | 24% |
| 17-85 | 85 | 21-35 | 79 | 54.3 | 119.7 | 55% | 99.1 | 45% |
| 21-130 | 130 | 25-35 | 128 | 68.7 | 159.3 | 57% | 136.6 | 50% |

Size Comparison: 2M801 VS. D38999 Series III

| 2M801 Layout | Cable Plug Diameter | | | | | Jam Nut Receptacle Diameter | | | | |
|--------------|---------------------|-------|--------|-------|-------------|-----------------------------|-------|--------|-------|-------------|
| | 2M801 | | D38999 | | % Reduction | 2M801 | | D38999 | | % Reduction |
| | In. | mm. | In. | mm. | | In. | mm. | In. | mm. | |
| 5-3 | .540 | 13.72 | .859 | 21.82 | 37% | .575 | 14.61 | 1.204 | 30.58 | 52% |
| 6-7 | .600 | 15.24 | .859 | 21.82 | 30% | .635 | 16.13 | 1.204 | 30.58 | 47% |
| 9-19 | .810 | 20.57 | 1.156 | 29.36 | 30% | .830 | 21.08 | 1.516 | 38.51 | 45% |
| 13-37 | 1.050 | 26.67 | 1.281 | 32.54 | 18% | 1.078 | 27.38 | 1.641 | 41.68 | 34% |
| 16-55 | 1.240 | 31.50 | 1.406 | 35.71 | 12% | 1.264 | 32.11 | 1.766 | 44.86 | 28% |
| 17-85 | 1.300 | 33.02 | 1.641 | 41.68 | 21% | 1.325 | 33.66 | 2.078 | 52.78 | 36% |
| 21-130 | 1.550 | 39.37 | 1.890 | 48.01 | 18% | 1.625 | 41.28 | 2.323 | 59.00 | 30% |

Note: Weights shown include contacts and represent a mated pair of plug and jam nut receptacle. Weights are in grams.

2M Series Technical Information

Inserts Arrangements

SERIES 2M INSERT ARRANGEMENTS

| CONTACT SIZE | CONTACT QUANTITY | | | | | INSERT ARRANGEMENT | | | |
|---|------------------|-----|-------|-----|--------|--------------------|--------|--------|--------|
| | #23 | #20 | #20HD | #16 | #12 | 2M801 | 2M803 | 2M804 | 2M805 |
| Size #23 Contacts 5 Amp Max. Current 750 VAC #22-#28 AWG | 3 | | | | | 5-3 | 5-3 | 5-3 | NA |
| | 4 | | | | | 6-4 | 6-4 | 6-4 | 8-4 |
| | 6 | | | | | 6-6 | 6-6 | 6-6 | 8-6 |
| | 7 | | | | | 6-7 | 6-7 | 6-7 | 8-7 |
| | 10 | | | | | 7-10 | 7-10 | 7-10 | 9-10 |
| | 13 | | | | | 8-13 | 8-13 | 8-13 | 10-13 |
| | 19 | | | | | 9-19 | 9-19 | 9-19 | 11-19 |
| | 26 | | | | | 10-26 | 10-26 | 10-26 | 12-26 |
| | 37 | | | | | 13-37 | 12-37 | 12-37 | 15-37 |
| | 55 | | | | | 16-55 | 14-55 | 14-55 | 18-55 |
| | 85 | | | | | 17-85 | 15-85 | 15-85 | 19-85 |
| 130 | | | | | 21-130 | NA | NA | 23-130 | |
| Size #20HD Contacts 7.5 Amp Max. Current 1000 VAC #20-#24 AWG. | | | 3 | | | 6-23 | 6-23 | 6-23 | 8-23 |
| | | | 5 | | | 7-25 | 7-25 | 7-25 | 9-25 |
| | | | 8 | | | 8-28 | 8-28 | 8-28 | 10-28 |
| | | | 10 | | | 9-210 | 9-210 | 9-210 | 11-210 |
| | | | 20 | | | 13-220 | 12-220 | 12-220 | 15-220 |
| | | | 35 | | | 16-235 | 14-235 | 14-235 | 18-235 |
| | | | 41 | | | 17-241 | NA | NA | 19-241 |
| | | 69 | | | 21-269 | NA | NA | 23-269 | |
| Size #16 Contacts 13 Amp Max. Current 1800 VAC #16-#20 AWG | | | | 1 | | 6-1 | 6-1 | 6-1 | 8-1 |
| | | | | 2 | | 8-2 | 8-2 | 8-2 | 10-2 |
| | | | | 4 | | 9-4 | 9-4 | 9-4 | 11-4 |
| | | | | 5 | | 10-5 | 10-5 | 10-5 | 12-5 |
| | | | | 7 | | 13-7 | 12-7 | 12-7 | 15-7 |
| | | | | 12 | | 16-12 | 14-12 | 14-12 | 18-12 |
| | | | | 14 | | 17-14 | 15-14 | 15-14 | 19-14 |
| | | | | 22 | | 21-22 | NA | NA | 23-22 |
| Size #12 Contacts 23 Amp Max. Current 1800 VAC #12-14 AWG | | | | | 1 | 7-1 | 7-1 | 7-1 | 9-1 |
| | | | | | 2 | 10-2 | 10-2 | 10-2 | 12-2 |
| | | | | | 2 | 13-2 | 12-2 | 12-2 | 15-2 |
| | | | | | 3 | 13-3 | 12-3 | 12-3 | 15-3 |
| | | | | | 5 | 16-5 | 14-5 | 14-5 | 18-5 |
| | | | | | 7 | 17-7 | 15-7 | 15-7 | 19-7 |
| | | | | | 12 | 21-12 | NA | NA | 23-12 |
| Insert Arrangements with Mixed Size (Combo) Layouts | 4 | 2 | | | | 8-200 | 8-200 | 8-200 | 10-200 |
| | 8 | 2 | | | | 9-201 | 9-201 | 9-201 | 11-201 |
| | 4 | | | 2 | | 9-200 | 9-200 | 9-200 | 11-200 |
| | 8 | | | 2 | | 10-202 | 10-202 | 10-202 | 12-202 |
| | 4 | | | | 2 | 10-201 | 10-201 | 10-201 | 12-201 |
| | 6 | | | | 2 | 13-200 | 12-200 | 12-200 | 15-200 |
| | 10 | | | | 2 | 13-201 | 12-201 | 12-201 | 15-201 |
| | 12 | | | | 1 | 10-200 | 10-200 | 10-200 | 12-200 |

2M Series Technical Information

Insert Arrangements



Technical Reference

Front face of pin inserts illustrated (Socket Reversed)

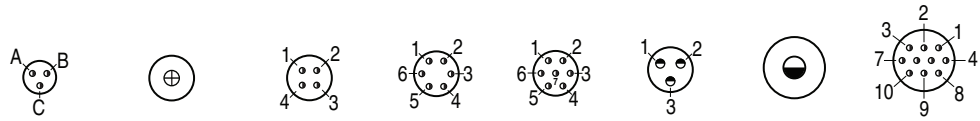

| | | | | | | | | |
|--------------------------|------------|-------------|------------|------------|------------|-------------|-------------|-------------|
| 2M801 2M803 2M804 | 5-3 | 6-1* | 6-4 | 6-6 | 6-7 | 6-23 | 7-1* | 7-10 |
| 2M805 | NA | 8-1* | 8-4 | 8-6 | 8-7 | 8-23 | 9-1* | 9-10 |
| No. of Contacts | 3 | 1 | 4 | 6 | 7 | 3 | 1 | 10 |
| Contact Size | #23 | #16 | #23 | #23 | #23 | #20HD | #12 | #23 |
| DWV Voltage (VAC) | 750 | 1800 | 750 | 750 | 750 | 1000 | 1800 | 750 |
| Current Rating (Amps) | 5 | 13 | 5 | 5 | 5 | 7.5 | 23 | 5 |

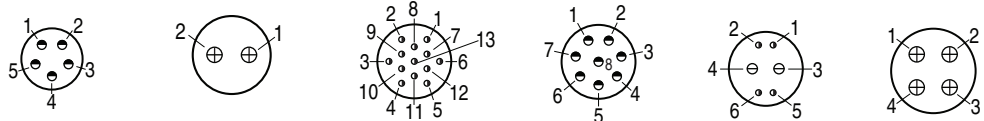

| | | | | | | |
|--------------------------|-------------|-------------|--------------|--------------|----------------|-------------|
| 2M801 2M803 2M804 | 7-25 | 8-2 | 8-13 | 8-28 | 8-200* | 9-4 |
| 2M805 | 9-25 | 10-2 | 10-13 | 10-28 | 10-200* | 11-4 |
| No. of Contacts | 5 | 2 | 13 | 8 | 2 4 | 4 |
| Contact Size | #20HD | #16 | #23 | #20HD | #20 #23 | #16 |
| DWV Voltage (VAC) | 1000 | 1800 | 750 | 1000 | 1000 750 | 1800 |
| Current Rating (Amps) | 7.5 | 13 | 5 | 7.5 | 7 5 | 13 |

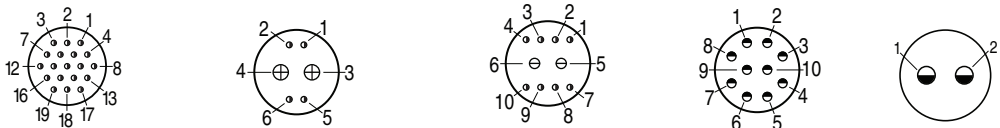

| | | | | | |
|--------------------------|--------------|---------------|---------------|---------------|-------------|
| 2M801 2M803 2M804 | 9-19 | 9-200 | 9-201 | 9-210 | 10-2 |
| 2M805 | 11-19 | 11-200 | 11-201 | 11-210 | 12-2 |
| No. of Contacts | 19 | 2 4 | 2 8 | 10 | 2 |
| Contact Size | #23 | #16 #23 | #20 #23 | #20HD | #12 |
| DWV Voltage (VAC) | 750 | 1800 750 | 1000 750 | 1000 | 1800 |
| Current Rating (Amps) | 5 | 13 5 | 7.5 5 | 7.5 | 23 |

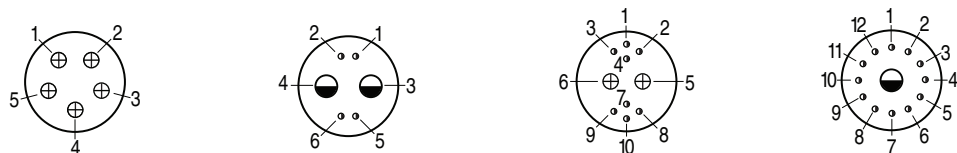

| | | | | |
|--------------------------|-------------|---------------|----------------|----------------|
| 2M801 2M803 2M804 | 10-5 | 10-201 | 10-202* | 10-200* |
| 2M805 | 12-5 | 12-201 | 12-202* | 12-200* |
| No. of Contacts | 5 | 2 4 | 2 8 | 1 12 |
| Contact Size | #16 | #12 #23 | #16 #23 | #12 #23 |
| DWV Voltage (VAC) | 1800 | 1800 750 | 1800 750 | 1800 750 |
| Current Rating (Amps) | 13 | 23 5 | 13 5 | 23 5 |

2M Series Technical Information

Insert Arrangements

Front face of pin inserts illustrated (Socket Reversed)

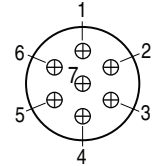
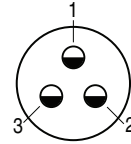
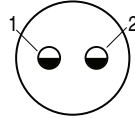
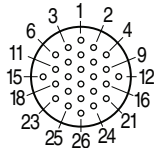

| | | | | |
|-----------------------|--------------|-------------|--------------|-------------|
| 2M801 | 10-26 | 13-2 | 13-3* | 13-7 |
| 2M803 2M804 | 10-26 | 12-2 | 12-3* | 12-7 |
| 2M805 | 12-26 | 15-2 | 15-3* | 15-7 |
| No. of Contacts | 26 | 2 | 3 | 7 |
| Contact Size | #23 | #12 | #12 | #16 |
| DWV Voltage (VAC) | 750 | 1800 | 1800 | 1800 |
| Current Rating (Amps) | 5 | 23 | 23 | 13 |

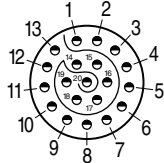
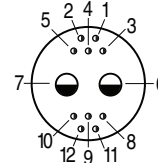
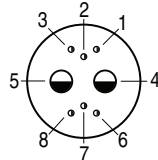
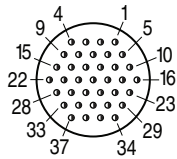

| | | | | | | |
|-----------------------|--------------|----------------|-----|---------------|-----|---------------|
| 2M801 | 13-37 | 13-200* | | 13-201 | | 13-220 |
| 2M803 2M804 | 12-37 | 12-200 | | 12-201 | | 12-220 |
| 2M805 | 15-37 | 15-200* | | 15-201 | | 15-220 |
| No. of Contacts | 37 | 2 | 6 | 2 | 10 | 20 |
| Contact Size | #23 | #12 | #23 | #12 | #23 | #20HD |
| DWV Voltage (VAC) | 750 | 1800 | 750 | 1800 | 750 | 1000 |
| Current Rating (Amps) | 5 | 23 | 5 | 23 | 5 | 7.5 |

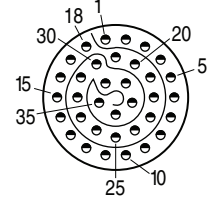
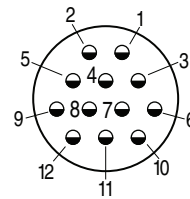
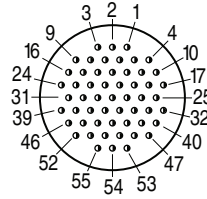
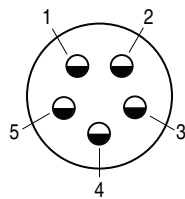

| | | | | |
|-----------------------|-------------|--------------|--------------|---------------|
| 2M801 | 16-5 | 16-55 | 16-12 | 16-235 |
| 2M803 2M804 | 14-5 | 14-55 | 14-12 | 14-235 |
| 2M805 | 18-5 | 18-55 | 18-12 | 18-235 |
| No. of Contacts | 5 | 55 | 12 | 35 |
| Contact Size | #12 | #23 | #16 | #20HD |
| DWV Voltage (VAC) | 1800 | 750 | 1800 | 1000 |
| Current Rating (Amps) | 23 | 5 | 13 | 7.5 |

*Not tooled for every insert pattern

2M Series Technical Reference

Insert Arrangements



Front face of pin inserts illustrated (Socket Reversed)

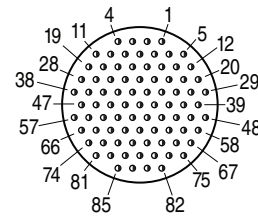
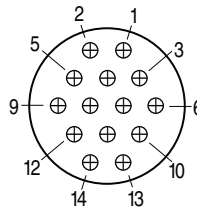
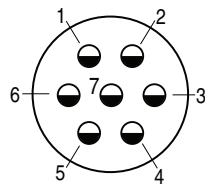

| | | | |
|-----------------------|-------------|---------------|--------------|
| 2M801 | 17-7 | 17-14* | 17-85 |
| 2M803 2M804 | 15-7 | 15-14 | 15-85 |
| 2M805 | 19-7 | 19-14* | 19-85 |
| No. of Contacts | 7 | 14 | 85 |
| Contact Size | #12 | #16 | #23 |
| DWV Voltage (VAC) | 1800 | 1800 | 750 |
| Current Rating (Amps) | 23 | 13 | 5 |

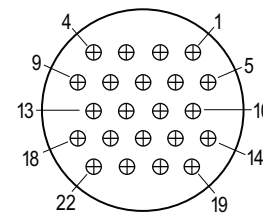
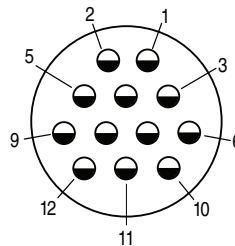
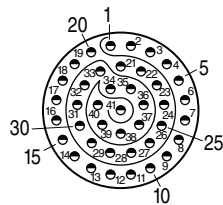

| | | | |
|-----------------------|----------------|--------------|---------------|
| 2M801 | 17-241* | 21-12 | 21-22* |
| 2M805 | 19-241* | 23-12 | 23-22* |
| No. of Contacts | 41 | 12 | 22 |
| Contact Size | #20HD | #12 | #16 |
| DWV Voltage (VAC) | 1000 | 1800 | 1800 |
| Current Rating (Amps) | 7.5 | 23 | 13 |

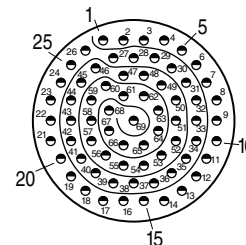
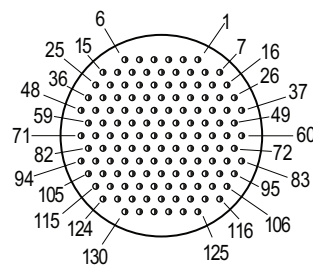







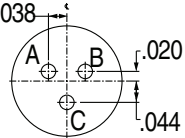
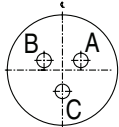

| | | |
|-----------------------|---------------|---------------|
| 2M801 | 21-130 | 21-269 |
| 2M805 | 23-130 | 23-269 |
| No. of Contacts | 130 | 69 |
| Contact Size | #23 | #20HD |
| DWV Voltage (VAC) | 750 | 1000 |
| Current Rating (Amps) | 5 | 7.5 |

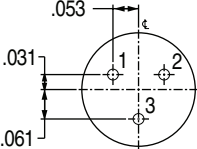
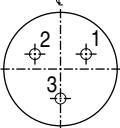
*Not tooled for every insert pattern

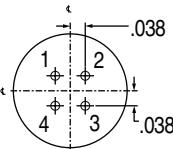
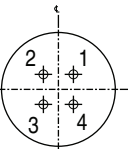
2M Series Technical Information

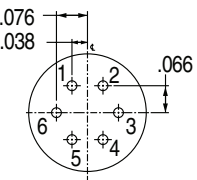
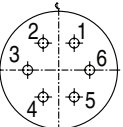
Straight PCB Footprints

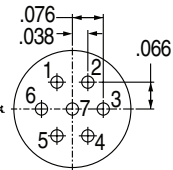
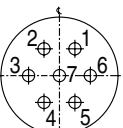
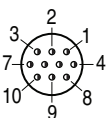
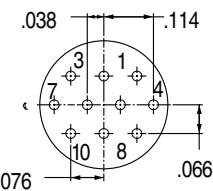
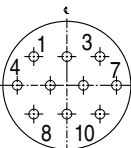

| INSERT ARRANGEMENT | PIN CONNECTOR | SOCKET CONNECTOR |
|--|---|---|
|  <p>5-3 (3) #23 Contacts .022 Max. Dia Tail</p> |  |  |
|  <p>6-23, 8-23 (3) #20HD Contacts .023 Max. Dia. Tail</p> |  |  |
|  <p>6-4, 8-4 (4) #23 Contacts .022 Max. Dia Tail</p> |  |  |
|  <p>6-6, 8-6 (6) #23 Contacts .022 Max. Dia. Tail</p> |  |  |
|  <p>6-7, 8-7 (7) #23 Contacts .022 Max. Dia. Tail</p> |  |  |
|  <p>7-10, 9-10 10 #23 Contacts .022 Max. Dia. Tail</p> |  |  |

Socket inserts are a mirror image of pin side. Socket side shown for cavity locations only, reference pin side for dimensions.

2M Series Technical Reference

Straight PCB Footprints

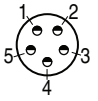
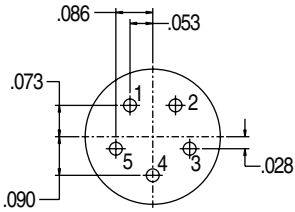
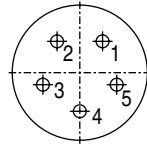

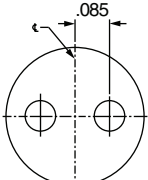
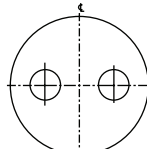
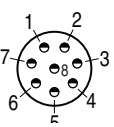
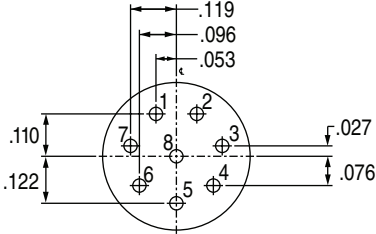
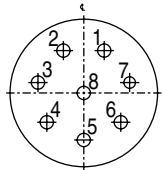
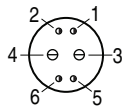
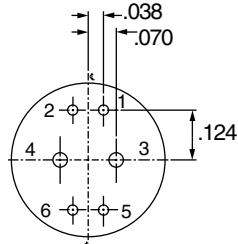
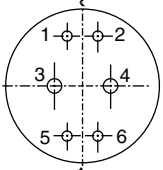
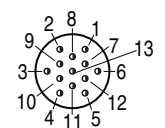
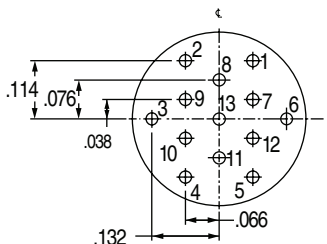
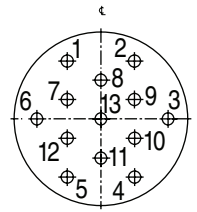
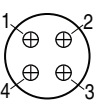
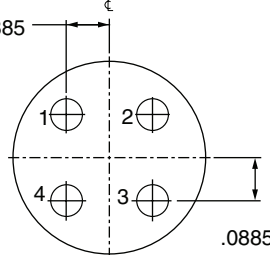
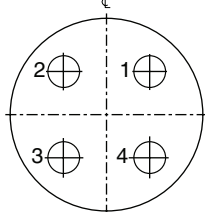
| INSERT ARRANGEMENT | PIN CONNECTOR | SOCKET CONNECTOR |
|--|---|---|
|  <p>7-25, 9-25 (5) #20HD Contacts .028 Max. Dia Tail</p> |  |  |
|  <p>8-2, 10-2 (2) #16 Contacts</p> |  |  |
|  <p>8-28, 10-28 (8) #20HD Contacts</p> |  |  |
|  <p>8-200*, 10-200* (2) #20 Contacts (4) #23 Contacts</p> |  |  |
|  <p>8-13, 10-13 (13) #23 Contacts .022 Max. Dia. Tail</p> |  |  |
|  <p>9-4, 11-4 (4) #16 Contacts</p> |  |  |

*Not tooled for every insert pattern

2M Series Technical Information

Straight PCB Footprints

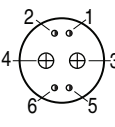
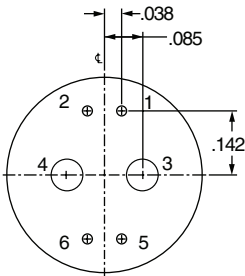
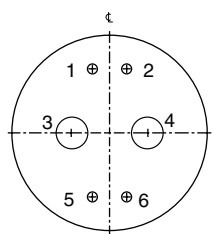
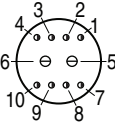
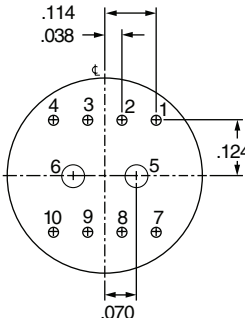
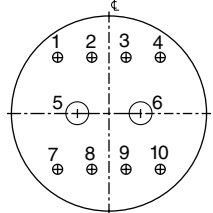
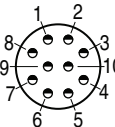
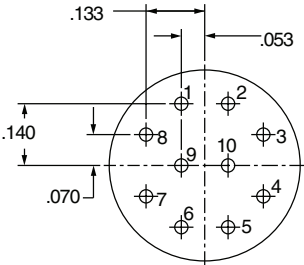
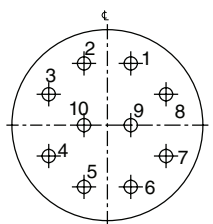
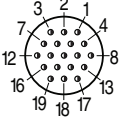
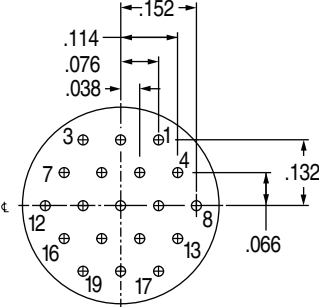
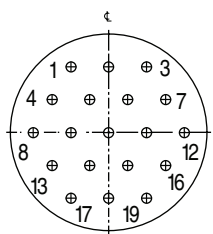
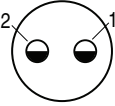
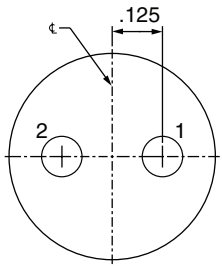
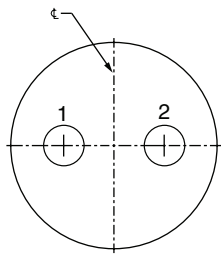
| INSERT ARRANGEMENT | PIN CONNECTOR | SOCKET CONNECTOR |
|---|---|---|
|  <p>9-200, 11-200 (4) #23 Contacts (2) #16 Contacts</p> |  |  |
|  <p>9-201, 11-201 (2) #20 Contacts (8) #23 Contacts</p> |  |  |
|  <p>9-210*, 11-210* (10) #20HD Contacts</p> |  |  |
|  <p>9-19, 11-19 (19) #23 Contacts .022 Max. Dia Tail</p> |  |  |
|  <p>10-2, 12-2 (2) #12 Contacts</p> |  |  |

*Not tooled for every insert pattern

2M Series Technical Reference

Straight PCB Footprints

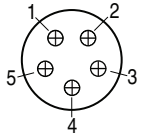
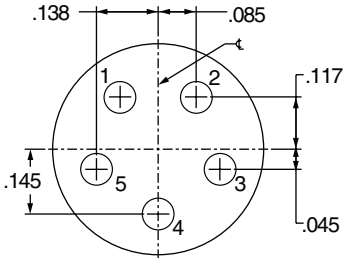
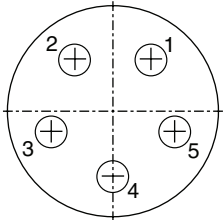
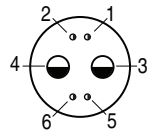
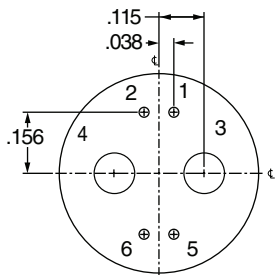
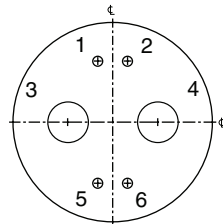
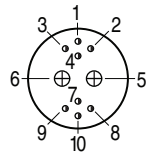
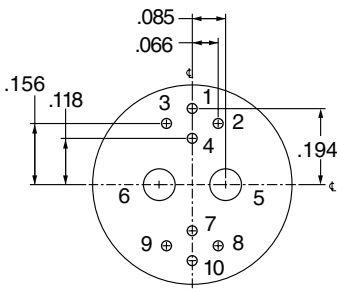
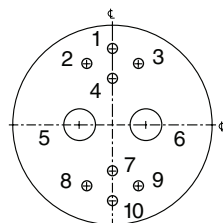
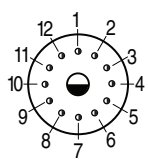
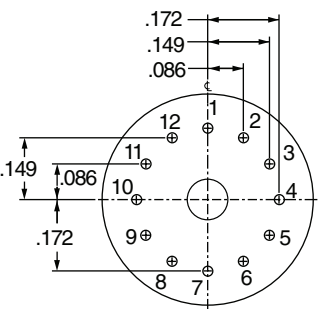
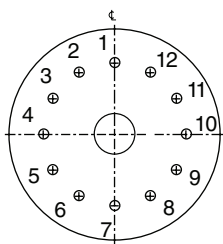
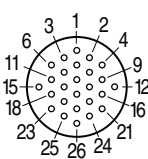
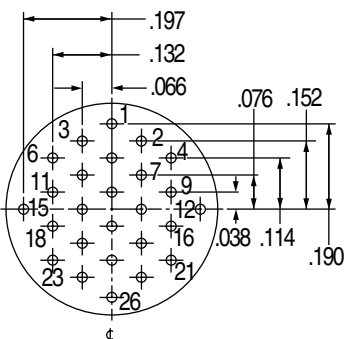
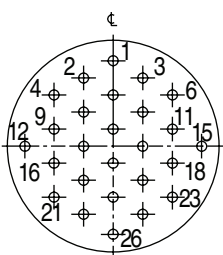

| INSERT ARRANGEMENT | PIN CONNECTOR | SOCKET CONNECTOR |
|---|---|---|
|  <p>10-5, 12-5 (5) #16 Contacts</p> |  |  |
|  <p>10-201, 12-201 (2) #12 Contacts (4) #23 Contacts</p> |  |  |
|  <p>10-202*, 12-202* (2) #16 Contacts (8) #23 Contacts</p> |  |  |
|  <p>10-200*, 12-200* (1) #12 Contact (12) #23 Contacts</p> |  |  |
|  <p>10-26, 12-26 (26) #23 Contacts .022 Max. Dia. Tail</p> |  |  |

*Not tooled for every insert pattern

2M Series Technical Information

Straight PCB Footprints

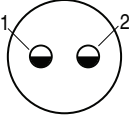
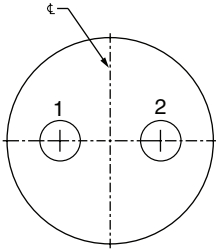
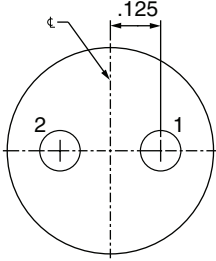
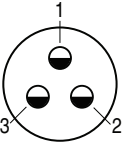
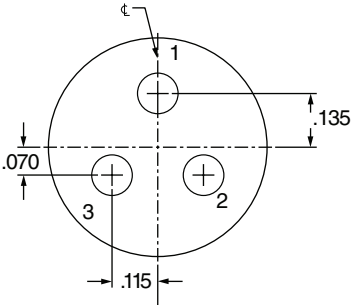
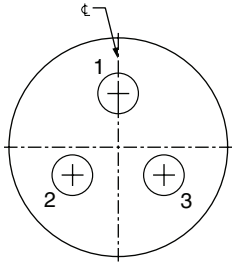
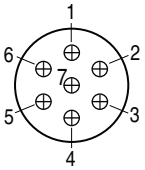
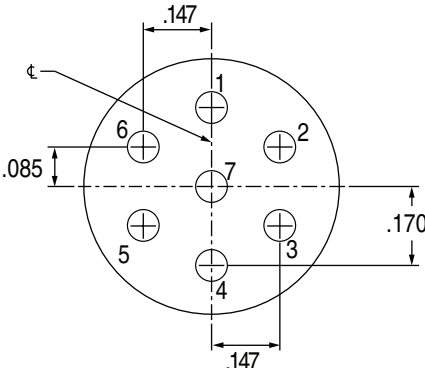
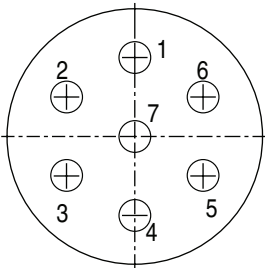
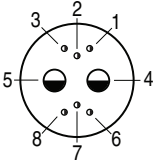
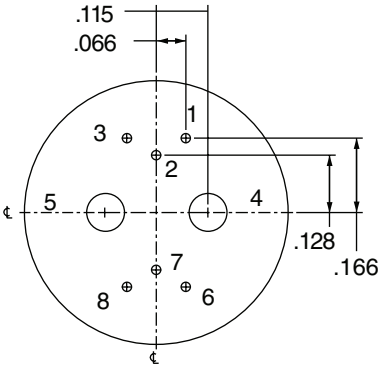
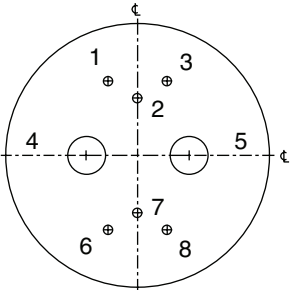
| INSERT ARRANGEMENT | PIN CONNECTOR | SOCKET CONNECTOR |
|--|---|---|
|  <p>12-2, 13-2, 15-2 (2) #12 Contacts</p> |  |  |
|  <p>12-3*, 13-3*, 15-3* (3) #12 Contacts</p> |  |  |
|  <p>12-7, 13-7, 15-7 (7) #16 Contacts</p> |  |  |
|  <p>12-200*, 13-200*, 15-200* (2) #12 Contacts (6) #23 Contacts</p> |  |  |

*Not tooled for every insert pattern

2M Series Technical Reference

Straight PCB Footprints

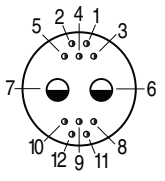
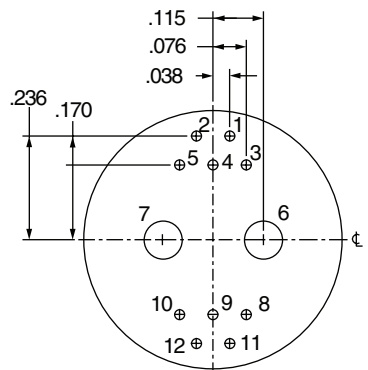
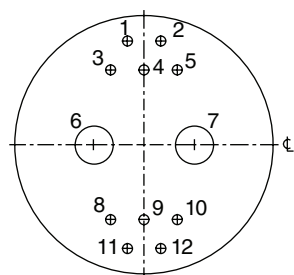
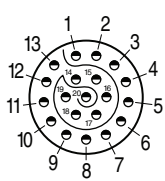
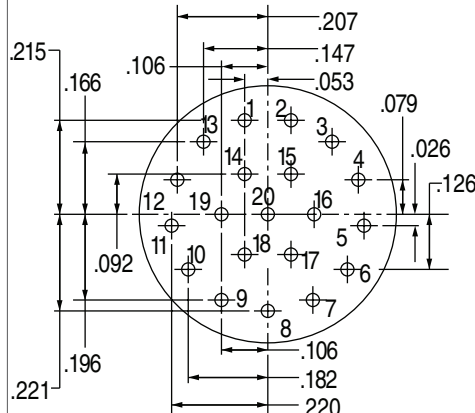
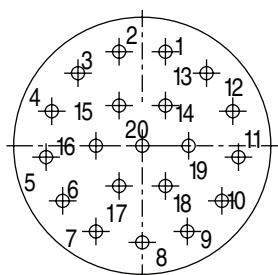
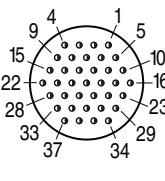
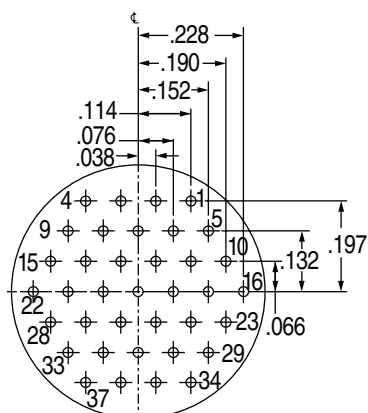
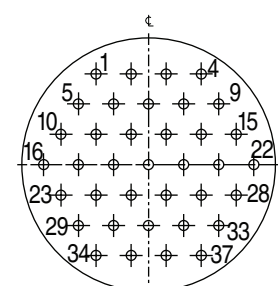
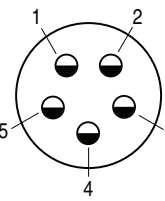
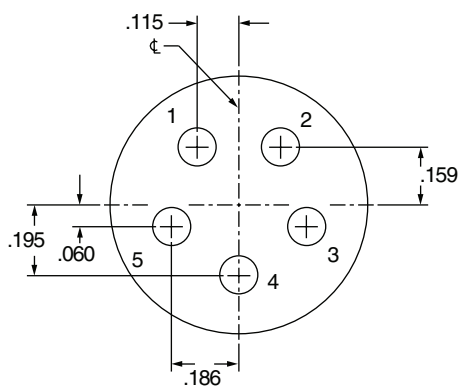
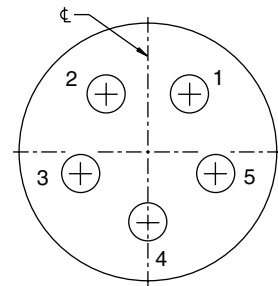

| INSERT ARRANGEMENT | PIN CONNECTOR | SOCKET CONNECTOR |
|--|---|---|
|  <p>12-201, 13-201, 15-201 (2) #12 Contacts (10) #23 Contacts</p> |  |  |
|  <p>12-220, 13-220, 15-220 (20) #20HD Contacts</p> |  |  |
|  <p>12-37, 13-37, 15-37 (37) #23 Contacts .022 Max. Dia. Tail</p> |  |  |
|  <p>14-5, 16-5, 18-5 (5) #12 Contacts</p> |  |  |

2M Series Technical Information

Straight PCB Footprints

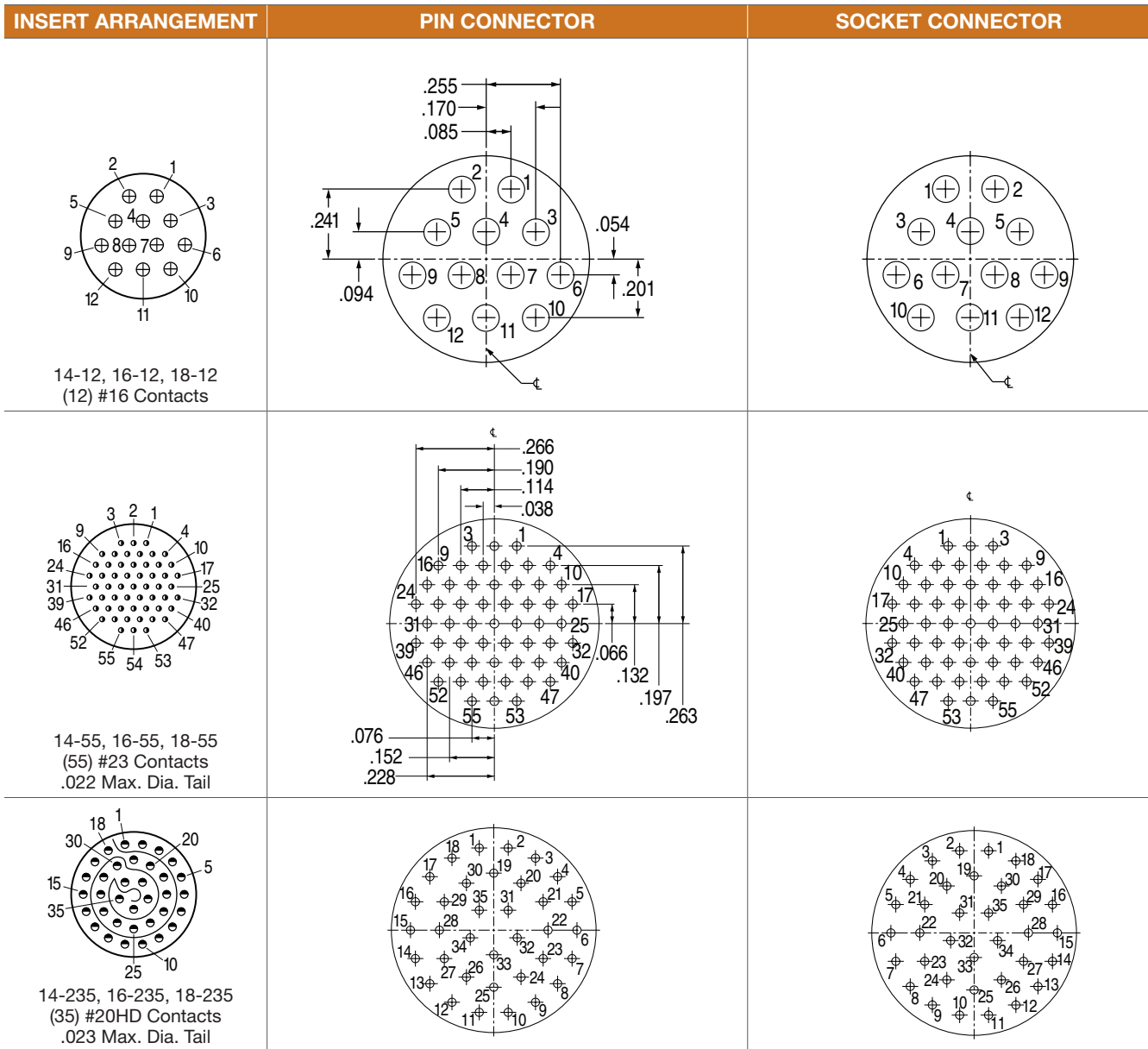

14-235, 16-235, 18-235

| Pin. No. | X | | Y | | Pin. No. | X | | Y | | Pin. No. | X | | Y | |
|----------|-------|-------|-------|-------|----------|-------|-------|-------|-------|----------|-------|-------|-------|-------|
| | in. | mm. | in. | mm. | | in. | mm. | in. | mm. | | in. | mm. | in. | mm. |
| 1 | -.053 | -1.35 | .301 | 7.65 | 13 | -.234 | -5.94 | -.196 | -4.98 | 25 | .000 | 0.00 | -.209 | -5.31 |
| 2 | .053 | 1.35 | .301 | 7.65 | 14 | -.287 | -7.29 | -.104 | -2.64 | 26 | -.100 | -2.54 | -.172 | -4.37 |
| 3 | .153 | 3.89 | .264 | 6.71 | 15 | -.305 | -7.75 | .000 | 0.00 | 27 | -.181 | -4.60 | -.104 | -2.64 |
| 4 | .234 | 5.94 | .196 | 4.98 | 16 | -.287 | 7.29 | .104 | 2.64 | 28 | -.199 | -5.05 | .000 | 0.00 |
| 5 | .287 | 7.29 | .104 | 2.64 | 17 | -.234 | -5.94 | .196 | 4.98 | 29 | -.181 | -4.60 | .104 | 2.64 |
| 6 | .305 | 7.75 | .000 | 0.00 | 18 | -.153 | -3.89 | .264 | 6.71 | 30 | -.100 | -2.54 | .172 | 4.37 |
| 7 | .287 | 7.29 | -.104 | -2.64 | 19 | .000 | 0.00 | .209 | 5.31 | 31 | -.053 | -1.35 | .073 | 1.85 |
| 8 | .234 | 5.94 | -.196 | -4.98 | 20 | .100 | 2.54 | .172 | 4.37 | 32 | .053 | 1.35 | .073 | 1.85 |
| 9 | .153 | 3.89 | -.264 | -6.71 | 21 | .181 | 4.60 | .104 | 2.64 | 33 | .086 | 2.18 | -.028 | -0.71 |
| 10 | .053 | 1.35 | -.301 | -7.65 | 22 | .199 | 5.05 | .000 | 0.00 | 34 | .000 | 0.00 | -.090 | -2.29 |
| 11 | -.053 | -1.35 | -.301 | -7.65 | 23 | .181 | 4.60 | -.104 | -2.64 | 35 | -.086 | -2.18 | -.028 | -0.71 |
| 12 | -.153 | -3.89 | -.264 | -6.71 | 24 | .100 | 2.54 | -.172 | -4.37 | | | | | |

2M Series Technical Reference

Straight PCB Footprints

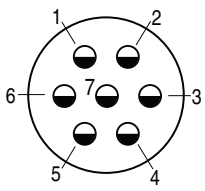
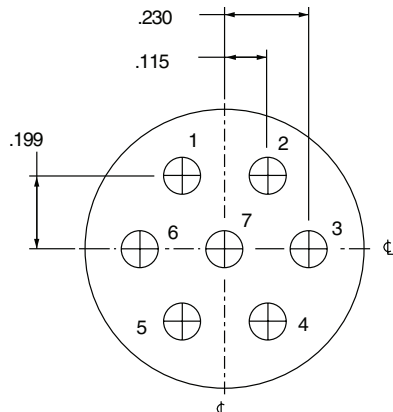
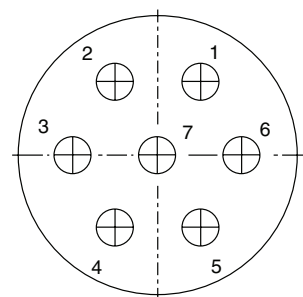
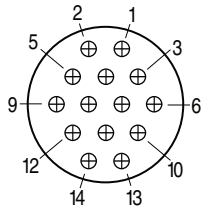
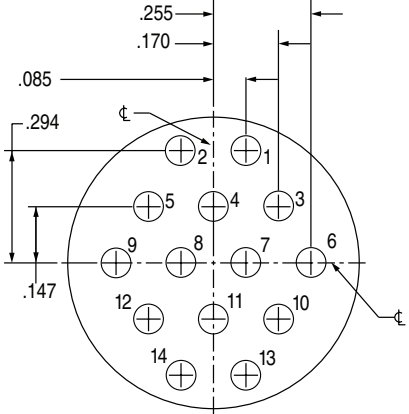
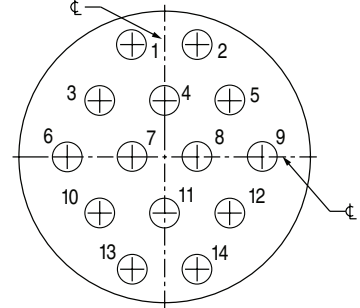
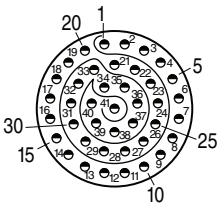
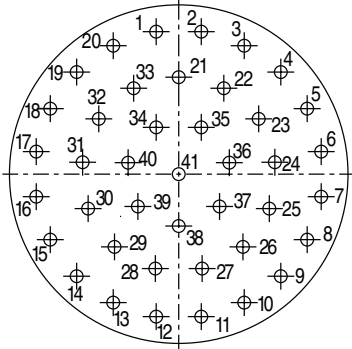
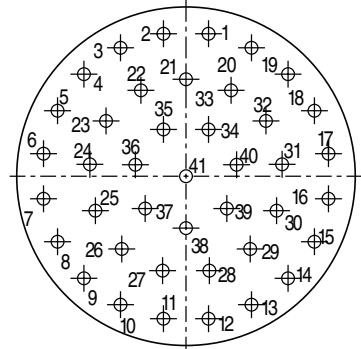

| INSERT ARRANGEMENT | PIN CONNECTOR | SOCKET CONNECTOR |
|---|---|---|
|  <p>15-7, 17-7, 19-7 (7) #12 Contacts</p> |  |  |
|  <p>15-14, 17-14, 19-14 (14) #16 Contacts</p> |  |  |
|  <p>17-241, 19-241 (41) #20HD Contacts .028 Max. Dia. Tail</p> |  |  |

17-241, 19-241

| Pin. No. | X | | Y | | Pin. No. | X | | Y | | Pin. No. | X | | Y | |
|----------|-------|-------|-------|-------|----------|-------|-------|-------|-------|----------|-------|-------|-------|-------|
| | in. | mm. | in. | mm. | | in. | mm. | in. | mm. | | in. | mm. | in. | mm. |
| 1 | -.053 | -1.35 | .335 | 8.51 | 15 | -.302 | -7.67 | -.154 | -3.91 | 29 | -.151 | -3.84 | -.171 | -4.34 |
| 2 | .053 | 1.35 | .335 | 8.51 | 16 | -.335 | -8.51 | -.053 | -1.35 | 30 | -.213 | -5.41 | -.081 | -2.06 |
| 3 | .154 | 3.91 | .302 | 7.67 | 17 | -.335 | -8.51 | .053 | 1.35 | 31 | -.226 | -5.74 | .028 | 0.71 |
| 4 | .240 | 6.10 | .240 | 6.10 | 18 | -.302 | -7.67 | .154 | 3.91 | 32 | -.188 | -4.78 | .130 | 3.30 |
| 5 | .302 | 7.67 | .154 | 3.91 | 19 | -.240 | -6.10 | .240 | 6.10 | 33 | -.106 | -2.69 | .202 | 5.13 |
| 6 | .335 | 8.51 | .053 | 1.35 | 20 | -.154 | -3.91 | .302 | 7.67 | 34 | -.053 | -1.35 | .110 | 2.79 |
| 7 | .335 | 8.51 | -.053 | -1.35 | 21 | .000 | 0.00 | .228 | 5.79 | 35 | .053 | 1.35 | .110 | 2.79 |
| 8 | .302 | 7.67 | -.154 | -3.91 | 22 | .106 | 2.69 | .202 | 5.13 | 36 | .119 | 3.02 | .027 | 0.69 |
| 9 | .240 | 6.10 | -.240 | -6.10 | 23 | .188 | 4.78 | .130 | 3.30 | 37 | .096 | 2.44 | -.076 | -1.93 |
| 10 | .154 | 3.91 | -.302 | -7.67 | 24 | .226 | 5.74 | .028 | 0.71 | 38 | .000 | 0.00 | -.122 | -3.10 |
| 11 | +.053 | +1.35 | -.335 | -8.51 | 25 | .213 | 5.41 | -.081 | -2.06 | 39 | -.096 | -2.44 | -.076 | -1.93 |
| 12 | -.053 | -1.35 | -.335 | -8.51 | 26 | .151 | 3.84 | -.171 | -4.34 | 40 | -.119 | -3.02 | .027 | 0.69 |
| 13 | -.154 | -3.91 | -.302 | -7.67 | 27 | .055 | 1.40 | -.222 | -5.64 | 41 | .000 | 0.00 | .000 | 0.00 |
| 14 | -.240 | -6.10 | -.240 | -6.10 | 28 | -.055 | -1.40 | -.222 | -5.64 | | | | | |

2M Series Technical Information

Straight PCB Footprints

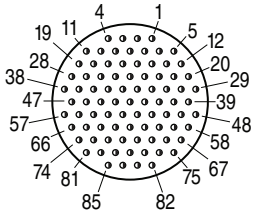
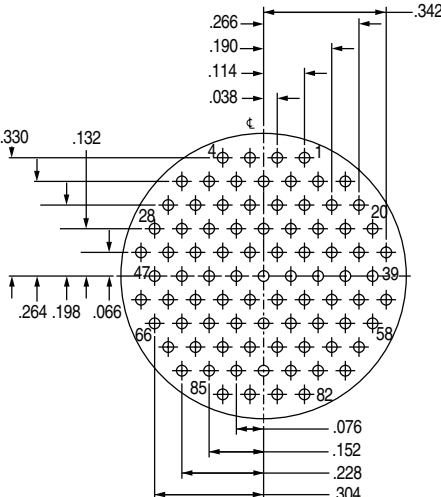
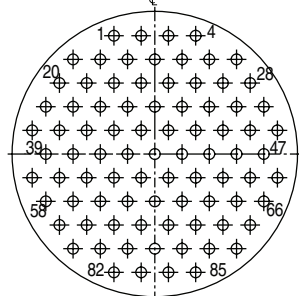
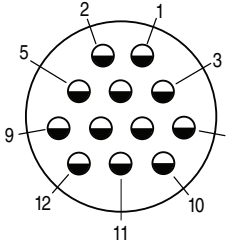
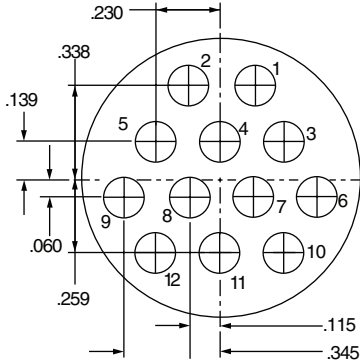
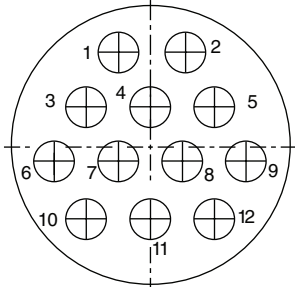
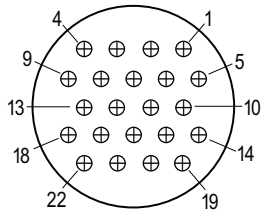
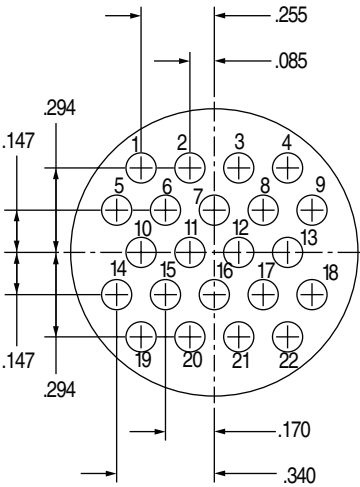
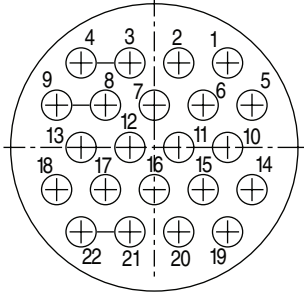
| INSERT ARRANGEMENT | PIN CONNECTOR | SOCKET CONNECTOR |
|---|---|---|
|  <p>17-85, 19-85 (85) #23 Contacts .022 Max. Dia. Tail</p> |  |  |
|  <p>21-12, 23-12 (12) #12 Contacts</p> |  |  |
|  <p>21-22*, 23-22* (22) #16 Contacts</p> |  |  |

*Not tooled for every insert pattern

2M Series Technical Reference

Straight PCB Footprints

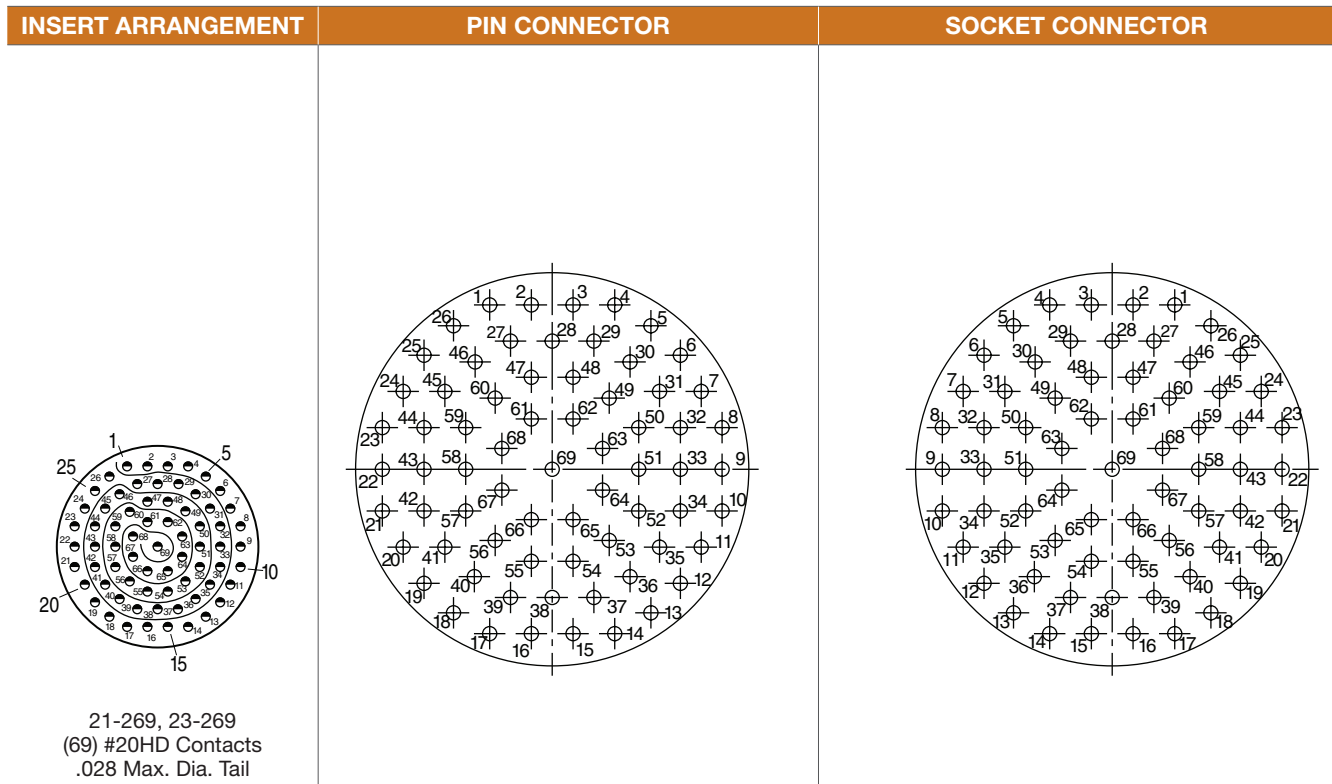

| 21-269, 23-269 | | | | | | | | | | | | | | |
|----------------|-------|--------|-------|--------|----------|-------|-------|-------|-------|----------|-------|-------|-------|-------|
| Pin. No. | X | | Y | | Pin. No. | X | | Y | | Pin. No. | X | | Y | |
| | in. | mm. | in. | mm. | | in. | mm. | in. | mm. | | in. | mm. | in. | mm. |
| 1 | -.159 | -4.04 | .418 | 10.62 | 24 | -.379 | -9.63 | .198 | 5.03 | 47 | -.053 | -1.35 | .234 | 5.94 |
| 2 | -.053 | -1.35 | .418 | 10.62 | 25 | -.326 | -8.28 | .290 | 7.37 | 48 | .053 | 1.35 | .234 | 5.94 |
| 3 | .053 | 1.35 | .418 | 10.62 | 26 | -.251 | -6.38 | .365 | 9.27 | 49 | .145 | 3.68 | .181 | 4.60 |
| 4 | .159 | 4.04 | .418 | 10.62 | 27 | -.106 | -2.69 | .326 | 8.28 | 50 | .220 | 5.59 | .106 | 2.69 |
| 5 | .251 | 6.38 | .365 | 9.27 | 28 | .000 | 0.00 | .326 | 8.28 | 51 | .220 | 5.59 | .000 | 0.00 |
| 6 | .326 | 8.28 | .290 | 7.37 | 29 | .106 | -2.69 | .326 | 8.28 | 52 | .220 | 5.59 | -.106 | -2.69 |
| 7 | .379 | 9.63 | .198 | 5.03 | 30 | .198 | 5.03 | .273 | 6.93 | 53 | .145 | 3.68 | -.181 | -4.60 |
| 8 | .432 | 10.97 | .106 | 2.69 | 31 | .273 | 6.93 | .198 | 5.03 | 54 | .053 | 1.35 | -.234 | -5.94 |
| 9 | .432 | 10.97 | .000 | 0.00 | 32 | .326 | 8.28 | .106 | 2.69 | 55 | -.053 | -1.35 | -.234 | -5.94 |
| 10 | .432 | 10.97 | -.106 | -2.69 | 33 | .326 | 8.28 | .000 | 0.00 | 56 | -.145 | -3.68 | -.181 | -4.60 |
| 11 | .379 | 9.63 | -.198 | -5.03 | 34 | .326 | 8.28 | -.106 | -2.69 | 57 | -.220 | -5.59 | -.106 | -2.69 |
| 12 | .326 | 8.28 | -.290 | -7.37 | 35 | .273 | 6.93 | -.198 | -5.03 | 58 | -.220 | -5.59 | .000 | 0.00 |
| 13 | .251 | 6.38 | -.365 | -9.27 | 36 | .198 | 5.03 | -.273 | -6.93 | 59 | -.220 | -5.59 | .106 | 2.69 |
| 14 | .159 | 4.04 | -.418 | -10.62 | 37 | .106 | 2.69 | -.326 | -8.28 | 60 | -.145 | -3.68 | .181 | 4.60 |
| 15 | .053 | 1.35 | -.418 | -10.62 | 38 | .000 | 0.00 | -.326 | -8.28 | 61 | -.053 | -1.35 | .128 | 3.25 |
| 16 | -.053 | -1.35 | -.418 | -10.62 | 39 | -.106 | -2.69 | -.326 | -8.28 | 62 | .053 | 1.35 | .128 | 3.25 |
| 17 | -.159 | -4.04 | -.418 | -10.62 | 40 | -.198 | -5.03 | -.273 | -6.93 | 63 | .128 | 3.25 | .053 | 1.35 |
| 18 | -.251 | -6.38 | -.365 | -9.27 | 41 | -.273 | -6.93 | -.198 | -5.03 | 64 | .128 | 3.25 | -.053 | -1.35 |
| 19 | -.326 | -8.28 | -.290 | -7.37 | 42 | -.326 | -8.28 | -.106 | -2.69 | 65 | .053 | 1.35 | -.128 | -3.25 |
| 20 | -.379 | -9.63 | -.198 | -5.03 | 43 | -.326 | -8.28 | .000 | 0.00 | 66 | -.053 | -1.35 | -.128 | -3.25 |
| 21 | -.432 | -10.97 | -.106 | -2.69 | 44 | -.326 | -8.28 | .106 | 2.69 | 67 | -.128 | -3.25 | -.053 | -1.35 |
| 22 | .432 | -10.97 | .000 | 0.00 | 45 | -.273 | -6.93 | .198 | 5.03 | 68 | -.128 | -3.25 | .053 | 1.35 |
| 23 | -.432 | -10.97 | .106 | 2.69 | 46 | -.198 | -5.03 | .273 | 6.93 | 69 | .000 | 0.00 | .000 | 0.00 |

2M Series Technical Information

Straight PCB Footprints

Technical Reference

INSERT ARRANGEMENT

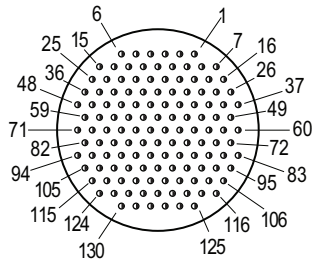

21-130, 23-130
(130) #23 Contacts
.022 Max. Dia Tail

PIN CONNECTOR

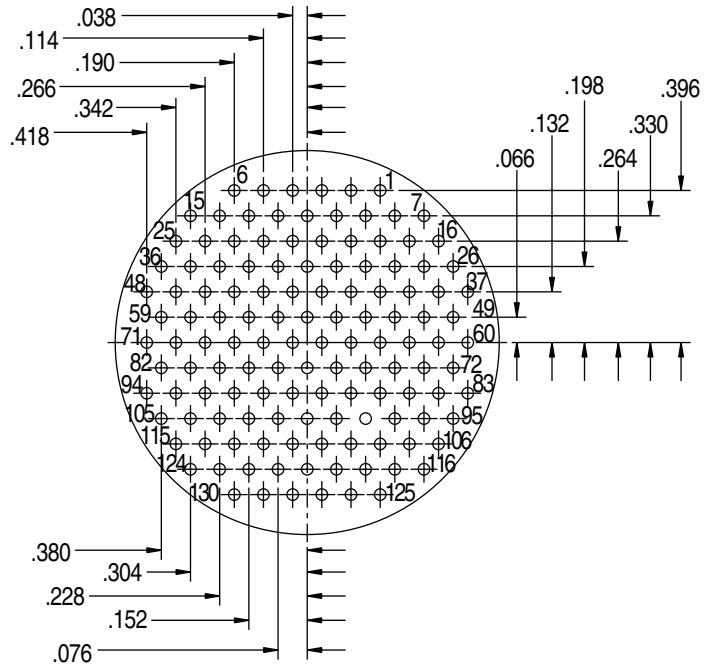

SOCKET CONNECTOR

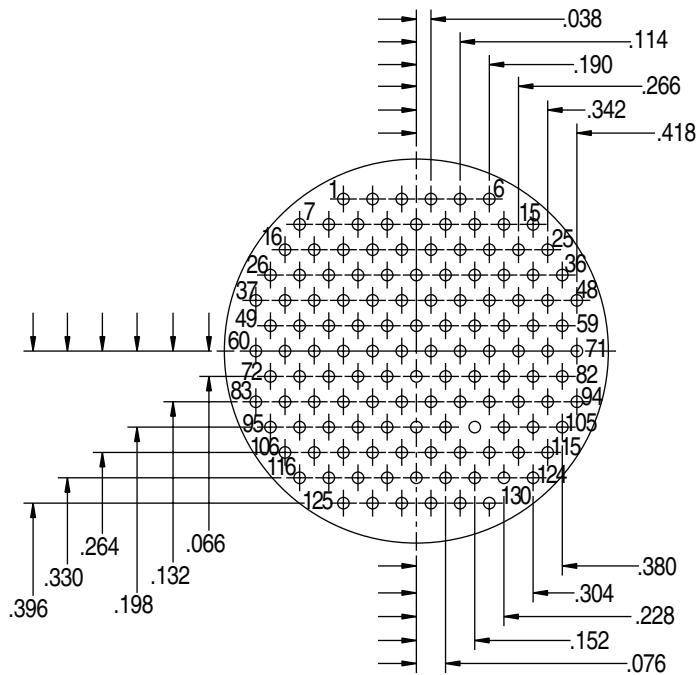

2M Series Performance Specifications

Materials and Finishes



PERFORMANCE SPECIFICATIONS

| | |
|--|---|
| Current Rating (Maximum) | Size #23 contact: 5 AMPS. Size #20 contact: 7.5 AMPS. Size #16 contact: 13 AMPS. Size #12 contact: 23 AMPS. |
| Test Voltage (Dielectric Withstanding Voltage) Mated Connectors | Size #23 contacts: 750 VAC RMS sea level, 400 VAC RMS 40,000 feet Size #20 contacts: 1000 VAC RMS sea level, 400 VAC RMS 40,000 feet Size #20HD contacts: 1000 VAC RMS sea level, 400 VAC RMS 40,000 feet Size #16 contacts: 1800 VAC RMS sea level, 1000 VAC RMS 40,000 feet Size #12 contacts: 1800 VAC RMS sea level, 1000 VAC RMS 40,000 feet |
| Insulation Resistance | 5000 megohms minimum |
| Contact Resistance | Size #23 contact: 73 millivolt drop at 5 AMPS. test current Size #20 contact: 55 millivolt drop at 7.5 AMPS. test current Size #16 contact: 49 millivolt drop at 13 AMPS. test current Size #12 contact: 42 millivolt drop at 23 AMPS. test current |
| Operating Temperature | -65° C. to +175° C. |
| Immersion, Mated | 1 meter water immersion for 1 hour (2M803 Series splash proof only) |
| Magnetic Permeability | 2.0 μ maximum |

MATERIALS AND FINISHES

| | |
|---|------------------------------------|
| Aluminum Shell, Barrel, and Coupling Nut | Aluminum alloy 6061 T6 |
| Stainless Steel Shell, Barrel Coupling Nut | Passivated Stainless Steel, 200° C |
| Front and Rear Inserts | Polyphenylene Sulfide (PPS) |
| Contact Retention Clip | Beryllium copper, heat-treated |
| Grommet, Peripheral Seal and Interfacial Seal | Fluorosilicone Rubber |
| Contacts | Gold Plated Copper alloy |
| Socket Contact Hood | Passivated Stainless steel |
| Adhesives | Various Epoxies & RTV's |
| Potting Compound, PCB and Solder Cup Versions | High Strength Epoxy |

Please refer to the comprehensive 2M Series Product Specification for additional parameters and test methods.
Filter and Hermetic designs have different specifications. (Please refer to individual sections)

Contact Amphenol Aerospace for more information at 800-678-0141 • www.amphenol-aerospace.com

2M Series Performance Specifications

Complete Product Specifications

| DESCRIPTION | REQUIREMENT | PROCEDURE | | | | | | | | | | | | | | | | | | | | | | | | | | | |
|---|---|--|----------------|------------------|----|----|----|----|-----|----|----|---------------------|----|----|-----|---|----|---|----|----|---|----|----|---|----|----|-----|----|--|
| ELECTRICAL | | | | | | | | | | | | | | | | | | | | | | | | | | | | | |
| Contact resistance | SAE AS39029 Table V <table border="1"> <thead> <tr> <th>Wire Size</th> <th>Test Current</th> <th>Max Voltage Drop</th> </tr> </thead> <tbody> <tr><td>12</td><td>23</td><td>42</td></tr> <tr><td>14</td><td>17</td><td>40</td></tr> <tr><td>16</td><td>13</td><td>49</td></tr> <tr><td>20</td><td>7.5</td><td>55</td></tr> <tr><td>22</td><td>5</td><td>73</td></tr> <tr><td>24</td><td>3</td><td>45</td></tr> <tr><td>26</td><td>2</td><td>52</td></tr> <tr><td>28</td><td>1.5</td><td>54</td></tr> </tbody> </table> | Wire Size | Test Current | Max Voltage Drop | 12 | 23 | 42 | 14 | 17 | 40 | 16 | 13 | 49 | 20 | 7.5 | 55 | 22 | 5 | 73 | 24 | 3 | 45 | 26 | 2 | 52 | 28 | 1.5 | 54 | EIA-364-06 Test current in amperes. Voltage drop in millivolts. Silver-coated copper wire, +25°C. |
| Wire Size | Test Current | Max Voltage Drop | | | | | | | | | | | | | | | | | | | | | | | | | | | |
| 12 | 23 | 42 | | | | | | | | | | | | | | | | | | | | | | | | | | | |
| 14 | 17 | 40 | | | | | | | | | | | | | | | | | | | | | | | | | | | |
| 16 | 13 | 49 | | | | | | | | | | | | | | | | | | | | | | | | | | | |
| 20 | 7.5 | 55 | | | | | | | | | | | | | | | | | | | | | | | | | | | |
| 22 | 5 | 73 | | | | | | | | | | | | | | | | | | | | | | | | | | | |
| 24 | 3 | 45 | | | | | | | | | | | | | | | | | | | | | | | | | | | |
| 26 | 2 | 52 | | | | | | | | | | | | | | | | | | | | | | | | | | | |
| 28 | 1.5 | 54 | | | | | | | | | | | | | | | | | | | | | | | | | | | |
| Low level contact resistance | <table border="1"> <thead> <tr> <th>Wire Size</th> <th>Max. Milliohms</th> </tr> </thead> <tbody> <tr><td>16</td><td>5</td></tr> <tr><td>20</td><td>9</td></tr> <tr><td>22</td><td>15</td></tr> <tr><td>24</td><td>20</td></tr> <tr><td>26</td><td>31</td></tr> <tr><td>28</td><td>50</td></tr> </tbody> </table> | Wire Size | Max. Milliohms | 16 | 5 | 20 | 9 | 22 | 15 | 24 | 20 | 26 | 31 | 28 | 50 | EIA-364-23 100 milliamperes maximum and 20 millivolts maximum open circuit voltage | | | | | | | | | | | | | |
| Wire Size | Max. Milliohms | | | | | | | | | | | | | | | | | | | | | | | | | | | | |
| 16 | 5 | | | | | | | | | | | | | | | | | | | | | | | | | | | | |
| 20 | 9 | | | | | | | | | | | | | | | | | | | | | | | | | | | | |
| 22 | 15 | | | | | | | | | | | | | | | | | | | | | | | | | | | | |
| 24 | 20 | | | | | | | | | | | | | | | | | | | | | | | | | | | | |
| 26 | 31 | | | | | | | | | | | | | | | | | | | | | | | | | | | | |
| 28 | 50 | | | | | | | | | | | | | | | | | | | | | | | | | | | | |
| Insulation resistance | 5000 megohms minimum | EIA-364-21 500 volts DC ± 50 volts. Test between adjacent contacts and contacts to shell. | | | | | | | | | | | | | | | | | | | | | | | | | | | |
| Dielectric withstanding voltage, sea level | No breakdown or flashover #23 contacts 750 volts #20HD contacts 750 volts #16 contacts 1800 volts #12 contacts 1800 volts | EIA-364-20 AC RMS 60 Hz. One minute dwell. Unmated or mated | | | | | | | | | | | | | | | | | | | | | | | | | | | |
| Dielectric withstanding voltage, 40,000 feet altitude | No breakdown or flashover #23 contacts 100 volts #20HD contacts 150 volts #16 contacts 1000 volts #12 contacts 1000 volts | EIA-364-20 AC RMS 60 Hz. One minute dwell. mated condition | | | | | | | | | | | | | | | | | | | | | | | | | | | |
| Current carrying capacity | <table border="1"> <thead> <tr> <th>Contact Size</th> <th>Max Current</th> </tr> </thead> <tbody> <tr><td>12</td><td>23</td></tr> <tr><td>16</td><td>13</td></tr> <tr><td>20</td><td>7.5</td></tr> <tr><td>23</td><td>5</td></tr> </tbody> </table> | Contact Size | Max Current | 12 | 23 | 16 | 13 | 20 | 7.5 | 23 | 5 | EIA-364-70 Method 1 | | | | | | | | | | | | | | | | | |
| Contact Size | Max Current | | | | | | | | | | | | | | | | | | | | | | | | | | | | |
| 12 | 23 | | | | | | | | | | | | | | | | | | | | | | | | | | | | |
| 16 | 13 | | | | | | | | | | | | | | | | | | | | | | | | | | | | |
| 20 | 7.5 | | | | | | | | | | | | | | | | | | | | | | | | | | | | |
| 23 | 5 | | | | | | | | | | | | | | | | | | | | | | | | | | | | |

Please refer to the comprehensive 2M Series Product Specification for additional parameters and test methods. Filter and Hermetic designs have different specifications. (Please refer to individual sections)

2M Series Performance Specifications

Complete Product Specifications



| DESCRIPTION | REQUIREMENT | PROCEDURE | | | | | | | | | | | | | | | | | | | | | | | | | | | | | | | |
|---|---|--------------|---------------------|-------|---------------------|--------------|--------------|---------------------|---------|-------|----|--|---------|----|----|--------|---------|----|--|----|---------|----|----|----|---------|----|----|----|----------|----|----|----|--|
| Shell-to-shell conductivity, Initial | <p>The maximum voltage drop across a mated pair shall not exceed the values shown.</p> <table border="1"> <thead> <tr> <th>Series</th> <th>Voltage Drop</th> </tr> </thead> <tbody> <tr> <td>2M801</td> <td>2.5</td> </tr> <tr> <td>2M803</td> <td>100</td> </tr> <tr> <td>2M804</td> <td>2</td> </tr> <tr> <td>2M805</td> <td>2</td> </tr> </tbody> </table> | Series | Voltage Drop | 2M801 | 2.5 | 2M803 | 100 | 2M804 | 2 | 2M805 | 2 | EIA-364-83 Electroless Nickel Plated Connectors | | | | | | | | | | | | | | | | | | | | | |
| Series | Voltage Drop | | | | | | | | | | | | | | | | | | | | | | | | | | | | | | | | |
| 2M801 | 2.5 | | | | | | | | | | | | | | | | | | | | | | | | | | | | | | | | |
| 2M803 | 100 | | | | | | | | | | | | | | | | | | | | | | | | | | | | | | | | |
| 2M804 | 2 | | | | | | | | | | | | | | | | | | | | | | | | | | | | | | | | |
| 2M805 | 2 | | | | | | | | | | | | | | | | | | | | | | | | | | | | | | | | |
| Shell-to-shell conductivity, after conditioning (48 hours salt spray) | <p>The maximum voltage drop across a mated pair shall not exceed the values shown.</p> <table border="1"> <thead> <tr> <th>Series</th> <th>Voltage Drop</th> </tr> </thead> <tbody> <tr> <td>2M801</td> <td>2.5</td> </tr> <tr> <td>2M803</td> <td>200</td> </tr> <tr> <td>2M804</td> <td>4</td> </tr> <tr> <td>2M805</td> <td>2</td> </tr> </tbody> </table> | Series | Voltage Drop | 2M801 | 2.5 | 2M803 | 200 | 2M804 | 4 | 2M805 | 2 | EIA-364-83 Electroless Nickel Plated Connectors | | | | | | | | | | | | | | | | | | | | | |
| Series | Voltage Drop | | | | | | | | | | | | | | | | | | | | | | | | | | | | | | | | |
| 2M801 | 2.5 | | | | | | | | | | | | | | | | | | | | | | | | | | | | | | | | |
| 2M803 | 200 | | | | | | | | | | | | | | | | | | | | | | | | | | | | | | | | |
| 2M804 | 4 | | | | | | | | | | | | | | | | | | | | | | | | | | | | | | | | |
| 2M805 | 2 | | | | | | | | | | | | | | | | | | | | | | | | | | | | | | | | |
| Shielding effectiveness, low frequency (100MHz-1000 MHz) | <table border="1"> <thead> <tr> <th rowspan="2">Frequency</th> <th colspan="3">dB Min. Attenuation</th> </tr> <tr> <th>Series 2M801</th> <th>Series 2M803</th> <th>Series 2M804, 2M805</th> </tr> </thead> <tbody> <tr> <td>100 MHz</td> <td>75</td> <td>60</td> <td>90</td> </tr> <tr> <td>200 MHz</td> <td>70</td> <td>55</td> <td>88</td> </tr> <tr> <td>300 MHz</td> <td>65</td> <td>55</td> <td>88</td> </tr> <tr> <td>400 MHz</td> <td>63</td> <td>50</td> <td>87</td> </tr> <tr> <td>800 MHz</td> <td>58</td> <td>45</td> <td>85</td> </tr> <tr> <td>1000 MHz</td> <td>55</td> <td>40</td> <td>85</td> </tr> </tbody> </table> | Frequency | dB Min. Attenuation | | | Series 2M801 | Series 2M803 | Series 2M804, 2M805 | 100 MHz | 75 | 60 | 90 | 200 MHz | 70 | 55 | 88 | 300 MHz | 65 | 55 | 88 | 400 MHz | 63 | 50 | 87 | 800 MHz | 58 | 45 | 85 | 1000 MHz | 55 | 40 | 85 | EIA-364-21 Electroless Nickel Plated Connectors |
| Frequency | dB Min. Attenuation | | | | | | | | | | | | | | | | | | | | | | | | | | | | | | | | |
| | Series 2M801 | Series 2M803 | Series 2M804, 2M805 | | | | | | | | | | | | | | | | | | | | | | | | | | | | | | |
| 100 MHz | 75 | 60 | 90 | | | | | | | | | | | | | | | | | | | | | | | | | | | | | | |
| 200 MHz | 70 | 55 | 88 | | | | | | | | | | | | | | | | | | | | | | | | | | | | | | |
| 300 MHz | 65 | 55 | 88 | | | | | | | | | | | | | | | | | | | | | | | | | | | | | | |
| 400 MHz | 63 | 50 | 87 | | | | | | | | | | | | | | | | | | | | | | | | | | | | | | |
| 800 MHz | 58 | 45 | 85 | | | | | | | | | | | | | | | | | | | | | | | | | | | | | | |
| 1000 MHz | 55 | 40 | 85 | | | | | | | | | | | | | | | | | | | | | | | | | | | | | | |
| Shielding effectiveness, high frequency (1GHz-10GHz) | <table border="1"> <thead> <tr> <th rowspan="2">Frequency</th> <th colspan="2">dB Min. Attenuation</th> </tr> <tr> <th>Series 2M801, 2M804</th> <th>Series 2M805</th> </tr> </thead> <tbody> <tr> <td>1 GHz</td> <td>55</td> <td>85</td> </tr> <tr> <td>3 GHz</td> <td>50</td> <td>69</td> </tr> <tr> <td>5 GHz</td> <td>45</td> <td>66</td> </tr> <tr> <td>19 GHz</td> <td>40</td> <td>65</td> </tr> </tbody> </table> | Frequency | dB Min. Attenuation | | Series 2M801, 2M804 | Series 2M805 | 1 GHz | 55 | 85 | 3 GHz | 50 | 69 | 5 GHz | 45 | 66 | 19 GHz | 40 | 65 | EIA-364-66 Electroless Nickel Plated Connectors | | | | | | | | | | | | | | |
| Frequency | dB Min. Attenuation | | | | | | | | | | | | | | | | | | | | | | | | | | | | | | | | |
| | Series 2M801, 2M804 | Series 2M805 | | | | | | | | | | | | | | | | | | | | | | | | | | | | | | | |
| 1 GHz | 55 | 85 | | | | | | | | | | | | | | | | | | | | | | | | | | | | | | | |
| 3 GHz | 50 | 69 | | | | | | | | | | | | | | | | | | | | | | | | | | | | | | | |
| 5 GHz | 45 | 66 | | | | | | | | | | | | | | | | | | | | | | | | | | | | | | | |
| 19 GHz | 40 | 65 | | | | | | | | | | | | | | | | | | | | | | | | | | | | | | | |

Perform Spec

Please refer to the comprehensive 2M Series Product Specification for additional parameters and test methods. Filter and Hermetic designs have different specifications. (Please refer to individual sections)

Contact Amphenol Aerospace for more information at 800-678-0141 • www.amphenol-aerospace.com

2M Series Performance Specifications

Complete Product Specifications

| DESCRIPTION | REQUIREMENT | PROCEDURE |
|---|---|--|
| MECHANICAL | | |
| Vibration, Sine | No discontinuity of greater than 1 microsecond, no cracking, breaking or loosening of parts, plug shall not become disengaged from receptacle. Connectors shall meet electrical requirements after vibration test. | MIL-STD-202 Method 204, test Condition G 12 sweep cycles per axes, 20 min. per 10-2000-10Hz @ temp. 2M801/2M805 - 60 g 2M803/2M804 - 30 g |
| Vibration, Random | No discontinuity of greater than 1 microsecond, no cracking, breaking or loosening of parts, plug shall not become disengaged from receptacle. Connectors shall meet electrical requirements after vibration test. | EIA-364-28 Test Condition V Letter I 100 milliamp test current 50- 2,000 Hz @ temp. 2M801/2M805 - 43.9 g RMS 2M803/2M804 - 37.80 g RMS |
| Gunfire Vibration | No discontinuity of greater than 1 microsecond, no cracking, breaking or loosening of parts, plug shall not become disengaged from receptacle. Connectors shall meet electrical requirements after vibration test. | MIL-STD-810F Method 519.5 |
| Mechanical Shock | No discontinuity of greater than 1 microsecond, no cracking, breaking or loosening of parts, plug shall not become disengaged from receptacle. Connectors shall meet electrical requirements after shock test. | EIA-364-27 Condition D 300 G, halvesine, 3ms, 3 axes |
| Mechanical durability, at ambient temperature | No deterioration which will adversely affect the connector after 2000 cycles (where applicable) of mating and unmating. Connectors shall meet contact resistance, insulation resistance, shell-to-shell resistance, DWV, and mating and unmating force. | EIA-364-09 |
| Solderability, PC tail contacts | 95% solder coverage. Smooth, bright and even finish. | EIA-364-52 Category 3 8 hours steam aging prior to test 245° C, 4-5 sec. dwell 10X magnification |
| Resistance To Soldering Heat | No damage to connector. Connectors shall meet insulation resistance and waterproof sealing requirements. | EIA-364-56 260° C, 10 seconds (PC tail) |

Please refer to the comprehensive 2M Series Product Specification for additional parameters and test methods. Filter and Hermetic designs have different specifications. (Please refer to individual sections)

2M Series Performance Specifications

Complete Product Specifications



| DESCRIPTION | REQUIREMENT | PROCEDURE | | | | | | | | | | | | | | | | | | | | | | | | | | | | | | |
|-------------------------------|---|----------------------------------|-------------|--------------|--------------|--------------|-------------|---------|------|------|------|--------|------|------|------|-------|-------------|-------|------|------------|------|----|--------|----|----|----|--|----|--|----|----|--|
| Impact | No impairment of function. Connector shall meet contact resistance, insulation resistance and waterproof sealing. | EIA-364-42 1 meter 8 drops | | | | | | | | | | | | | | | | | | | | | | | | | | | | | | |
| Contact retention | <table border="1"> <thead> <tr> <th>Contact Size</th> <th>Min. Pounds</th> <th>Min. Newtons</th> </tr> </thead> <tbody> <tr> <td>23</td> <td>10</td> <td>45</td> </tr> <tr> <td>20</td> <td>15</td> <td>67</td> </tr> <tr> <td>20HD</td> <td>10</td> <td>45</td> </tr> <tr> <td>16</td> <td>25</td> <td>111</td> </tr> <tr> <td>12</td> <td>25</td> <td>111</td> </tr> </tbody> </table> | Contact Size | Min. Pounds | Min. Newtons | 23 | 10 | 45 | 20 | 15 | 67 | 20HD | 10 | 45 | 16 | 25 | 111 | 12 | 25 | 111 | EIA-364-29 | | | | | | | | | | | | |
| Contact Size | Min. Pounds | Min. Newtons | | | | | | | | | | | | | | | | | | | | | | | | | | | | | | |
| 23 | 10 | 45 | | | | | | | | | | | | | | | | | | | | | | | | | | | | | | |
| 20 | 15 | 67 | | | | | | | | | | | | | | | | | | | | | | | | | | | | | | |
| 20HD | 10 | 45 | | | | | | | | | | | | | | | | | | | | | | | | | | | | | | |
| 16 | 25 | 111 | | | | | | | | | | | | | | | | | | | | | | | | | | | | | | |
| 12 | 25 | 111 | | | | | | | | | | | | | | | | | | | | | | | | | | | | | | |
| Contact separation force | <table border="1"> <thead> <tr> <th>Contact Size</th> <th>Min. Ounces</th> <th>Min. Newtons</th> </tr> </thead> <tbody> <tr> <td>23</td> <td>0.5</td> <td>0.14</td> </tr> <tr> <td>20</td> <td>0.7</td> <td>0.19</td> </tr> <tr> <td>16</td> <td>2.0</td> <td>0.56</td> </tr> <tr> <td>12</td> <td>3.0</td> <td>0.83</td> </tr> </tbody> </table> | Contact Size | Min. Ounces | Min. Newtons | 23 | 0.5 | 0.14 | 20 | 0.7 | 0.19 | 16 | 2.0 | 0.56 | 12 | 3.0 | 0.83 | SAE AS39029 | | | | | | | | | | | | | | | |
| Contact Size | Min. Ounces | Min. Newtons | | | | | | | | | | | | | | | | | | | | | | | | | | | | | | |
| 23 | 0.5 | 0.14 | | | | | | | | | | | | | | | | | | | | | | | | | | | | | | |
| 20 | 0.7 | 0.19 | | | | | | | | | | | | | | | | | | | | | | | | | | | | | | |
| 16 | 2.0 | 0.56 | | | | | | | | | | | | | | | | | | | | | | | | | | | | | | |
| 12 | 3.0 | 0.83 | | | | | | | | | | | | | | | | | | | | | | | | | | | | | | |
| Coupling torque | <p>Threaded coupling connector coupling torque shall not exceed the following requirements.</p> <table border="1"> <thead> <tr> <th colspan="3">Shell Size</th> </tr> <tr> <th>Series 2M801</th> <th>Series 2M805</th> <th>Inch Pounds</th> </tr> </thead> <tbody> <tr> <td>5, 6, 7</td> <td>8, 9</td> <td>8</td> </tr> <tr> <td>8, 9</td> <td>10, 11</td> <td>9</td> </tr> <tr> <td>10</td> <td>12</td> <td>12</td> </tr> <tr> <td>12, 13</td> <td>15</td> <td>16</td> </tr> <tr> <td>14, 15</td> <td>18</td> <td>28</td> </tr> <tr> <td>16, 17</td> <td>19</td> <td>24</td> </tr> <tr> <td>21</td> <td></td> <td>32</td> </tr> <tr> <td></td> <td>23</td> <td>36</td> </tr> </tbody> </table> | Shell Size | | | Series 2M801 | Series 2M805 | Inch Pounds | 5, 6, 7 | 8, 9 | 8 | 8, 9 | 10, 11 | 9 | 10 | 12 | 12 | 12, 13 | 15 | 16 | 14, 15 | 18 | 28 | 16, 17 | 19 | 24 | 21 | | 32 | | 23 | 36 | |
| Shell Size | | | | | | | | | | | | | | | | | | | | | | | | | | | | | | | | |
| Series 2M801 | Series 2M805 | Inch Pounds | | | | | | | | | | | | | | | | | | | | | | | | | | | | | | |
| 5, 6, 7 | 8, 9 | 8 | | | | | | | | | | | | | | | | | | | | | | | | | | | | | | |
| 8, 9 | 10, 11 | 9 | | | | | | | | | | | | | | | | | | | | | | | | | | | | | | |
| 10 | 12 | 12 | | | | | | | | | | | | | | | | | | | | | | | | | | | | | | |
| 12, 13 | 15 | 16 | | | | | | | | | | | | | | | | | | | | | | | | | | | | | | |
| 14, 15 | 18 | 28 | | | | | | | | | | | | | | | | | | | | | | | | | | | | | | |
| 16, 17 | 19 | 24 | | | | | | | | | | | | | | | | | | | | | | | | | | | | | | |
| 21 | | 32 | | | | | | | | | | | | | | | | | | | | | | | | | | | | | | |
| | 23 | 36 | | | | | | | | | | | | | | | | | | | | | | | | | | | | | | |
| Unmating force (Series 2M804) | <p>Series 2M804 push/pull connectors</p> <table border="1"> <thead> <tr> <th>Contact Arrangement</th> <th>Pounds</th> </tr> </thead> <tbody> <tr> <td>5-3</td> <td>10.6</td> </tr> <tr> <td>6-4</td> <td>10.8</td> </tr> <tr> <td>6-7</td> <td>11.4</td> </tr> <tr> <td>7-10</td> <td>12.0</td> </tr> <tr> <td>8-13</td> <td>12.6</td> </tr> <tr> <td>9-19</td> <td>13.8</td> </tr> <tr> <td>10-26</td> <td>15.2</td> </tr> <tr> <td>12-37</td> <td>17.4</td> </tr> <tr> <td>14-55</td> <td>21.0</td> </tr> </tbody> </table> | Contact Arrangement | Pounds | 5-3 | 10.6 | 6-4 | 10.8 | 6-7 | 11.4 | 7-10 | 12.0 | 8-13 | 12.6 | 9-19 | 13.8 | 10-26 | 15.2 | 12-37 | 17.4 | 14-55 | 21.0 | | | | | | | | | | | |
| Contact Arrangement | Pounds | | | | | | | | | | | | | | | | | | | | | | | | | | | | | | | |
| 5-3 | 10.6 | | | | | | | | | | | | | | | | | | | | | | | | | | | | | | | |
| 6-4 | 10.8 | | | | | | | | | | | | | | | | | | | | | | | | | | | | | | | |
| 6-7 | 11.4 | | | | | | | | | | | | | | | | | | | | | | | | | | | | | | | |
| 7-10 | 12.0 | | | | | | | | | | | | | | | | | | | | | | | | | | | | | | | |
| 8-13 | 12.6 | | | | | | | | | | | | | | | | | | | | | | | | | | | | | | | |
| 9-19 | 13.8 | | | | | | | | | | | | | | | | | | | | | | | | | | | | | | | |
| 10-26 | 15.2 | | | | | | | | | | | | | | | | | | | | | | | | | | | | | | | |
| 12-37 | 17.4 | | | | | | | | | | | | | | | | | | | | | | | | | | | | | | | |
| 14-55 | 21.0 | | | | | | | | | | | | | | | | | | | | | | | | | | | | | | | |

Please refer to the comprehensive 2M Series Product Specification for additional parameters and test methods. Filter and Hermetic designs have different specifications. (Please refer to individual sections)

Contact Amphenol Aerospace for more information at 800-678-0141 • www.amphenol-aerospace.com

Perform Spec

B

2M Series Performance Specifications

Complete Product Specifications

| DESCRIPTION | REQUIREMENT | PROCEDURE | | | |
|--|--|---|---------------------|---------------------|-----------------------------|
| Insert retention | No impairment of function. Connector shall meet contact resistance, insulation resistance and waterproof sealing. | EIA-365-35 | | | |
| | Shell Size | | | | |
| | Series 2M803, 2M804 | | Series 2M801 | Series 2M805 | Min. Force in Pounds |
| | 5 | | 5 | | 100 |
| | 6 | | 6 | 8 | 100 |
| | 7 | | 7 | 9 | 100 |
| | 8 | | 8 | 10 | 100 |
| | 9 | | 9 | 11 | 100 |
| | 10 | | 10 | 12 | 100 |
| | 12 | | 13 | 15 | 100 |
| | 14 | 16 | 18 | 100 | |
| | 15 | 17 | 19 | 100 | |
| | | 21 | 23 | 100 | |
| Magnetic Permeability | 2 μ maximum. | EIA-364-54 | | | |
| ENVIRONMENTAL | | | | | |
| Operating temperature | -65° to +175°C | | | | |
| Water immersion, mated | No evidence of water penetration into mated connectors. $\geq 100\Omega$ insulation resistance. | MIL-STD-810F Method 512.4 1 meter immersion 1 hour | | | |
| Water immersion, open face panel mount receptacles with non-removable printed circuit board or solder cup contacts | Connectors with waterblock potting process. 1 X 10 ⁻⁴ cc/second maximum helium leak rate at 1 atmosphere pressure differential following thermal shock conditioning. | EIA-365-02 3 cycles thermal shock -57°C to +71°C 75 min. dwell 5 minute transfer rate | | | |
| Humidity, cyclic (damp heat, cyclic) (moisture resistance) | No deterioration which will adversely affect the connector. 100 megohms minimum insulation resistance during the final cycle. Following the recovery period, connectors shall meet contact resistance, shell-to-shell resistance and DWV requirements. | EIA-364-31 Condition B Method III 80-98% RH 10 cycles (10 days) +25° C to +65° C Step 7b vibration deleted. 24 hour recovery period. | | | |

Please refer to the comprehensive 2M Series Product Specification for additional parameters and test methods. Filter and Hermetic designs have different specifications. (Please refer to individual sections)

2M Series Performance Specifications

Complete Product Specifications



| DESCRIPTION | REQUIREMENT | PROCEDURE |
|--|---|--|
| 21 day humidity (damp heat, long term) | No deterioration which will adversely affect the connector. Following the drying period, connectors shall meet 100 megohms minimum, contact resistance, shell-to-shell resistance, DWV, mating and unmating requirements. | EIA-364-31 Condition C Method II 90-95% RH 40° C Apply 100 volts DC during test. 4 hours drying time at ambient temperature prior to final measurements. |
| Thermal shock | No mechanical damage or loosening of parts. Following thermal shock, connector shall meet contact resistance, DWV, insulation resistance and shell-to-shell resistance requirements. | EIA-364-32 Test Condition IV 5 cycles consisting of -65° C 30 minutes, +25° C 5 minutes max., +150° C 30 minutes, +25° C 5 minutes max. |
| Corrosion (salt mist) | No exposure of base metal. Connectors shall meet DWV and contact resistance requirements following the test. | EIA-364-26 5% salt solution 35° C Unmated connectors Code C: 48 hours Code M: 48 hours Code MT: 500 hours Code NF: 500 hours Code ZNU: 500 hours |
| Sand and dust | Mated connectors shall withstand the effects of blowing sand and dust | MIL-STD-810F, Method 510.4 |
| Fungus | Connector materials shall be fungus inert. | MIL-STD-810F, Method 508.5 |
| Fluid immersion | No visible damage from immersion in various fuels and oils. Connector shall meet coupling torque and dielectric withstanding voltage requirements. | EIA-364-10 Unmated connectors |
| Altitude immersion | No evidence of moisture on connector interface or contacts. Connector shall meet dielectric withstanding voltage. | EIA-364-03 |

Please refer to the comprehensive 2M Series Product Specification for additional parameters and test methods. Filter and Hermetic designs have different specifications. (Please refer to individual sections)

Contact Amphenol Aerospace for more information at 800-678-0141 • www.amphenol-aerospace.com

2M805 Tri-Start Threaded Coupling

General Information

Page Guide

| | |
|------------------------|--------|
| Order..... | C29 |
| Weight..... | C30 |
| Plugs..... | C31 |
| In-Line..... | C32 |
| Square Flange..... | C33 |
| Jam Nut..... | C34 |
| PCB/ Sq Flange..... | C35 |
| PCB/Jam Nut..... | C36 |
| PCB Double Flange..... | C37 |
| Protection Cap..... | C38-39 |

Amphenol's 2M Micro38999 Connector Series... The New Aerospace Standard

Averaging less than half the size and weight of their 38999 ancestors, Amphenol's 2M Micro38999 series are an easy and inexpensive way to take weight out of your system. 2M meet or exceed most environmental and performance requirements listed in MIL-DTL-38999, so modernizing your equipment doesn't mean sacrificing ruggedness. With almost 2,000,000 configurations in every termination style and a full complement of accessories available right out of the catalog, customization has never been easier. Smarter, faster and smaller: Amphenol's 2M... the only connector you'll ever need.

2M805 Features

- Tri-start fast coupling
- Excellent EMI shielding
- Superior vibration resistance
- Waterproof
- Nickel plated ground spring



Why 2M805?

2M805 connectors are the evolution of the mil-standard circular. Designed to meet the same harsh environmental requirements of D38999, they were developed to make scaling-down existing technology easy and risk-free. Your systems are getting smaller, lighter, and faster; so why wouldn't your interconnect do the same? Less than half the size and weight of their 38999 predecessors, you can reduce size, reduce space, and reduce cost... but never reduce your expectations.

2M805 VS 38999

| Specification | 2M805 | MIL-DTL-38999 Series III |
|-----------------------------|--|--|
| Signal Count | 1 to 130 | 1 to 187 |
| Insulation Resistance | 5,000 megaohms min | 5,000 megaohms min |
| Operating Temperature | -65°C to +175°C | -65°C to +175°C |
| Shock | 300 G ± 15 | 300 G ± 15 |
| Vibration | "43.9 G Random 60.0 G Sine" | "43.9 G Random 60.0 G Sine" |
| Shielding Effectiveness | "85 dB min. from 100 MHz to 1000 MHz" | "65 dB min. from 100 MHz to 1000 MHz" |
| Durability | 500 mating cycles min. | 500 mating cycles |
| Shell to Shell Conductivity | 2.5 mV drop max | 2.5 mV drop max |
| Contacts | Per AS39029 | Per AS39029 |

2M805 MATERIALS AND FINISHES

| | |
|-----------------------------------|-----------------------------------|
| Shells | Aluminum Alloy or Stainless Steel |
| Contacts | Copper Alloy, gold plated |
| Insulators | Polyphenylene Sulfide (PPS) |
| Contact Retention | Beryllium Copper Alloy |
| Grommet, Interfacial Seal, O-Ring | Fluorosilicone Rubber |



2M805 Tri-Start Threaded Coupling

Ordering Guide for 2M805 Plugs & Receptacles

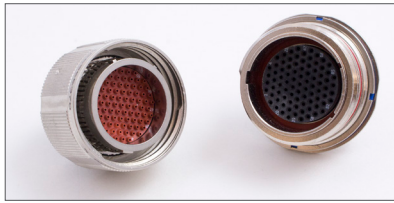

| 1. SERIES | 2. SHELL STYLE | 3. SERVICE CLASS | 4. SHELL SIZE INSERT ARRANGEMENT | 5. CONTACTS | 6. KEYING | 7. SUFFIX |
|-----------|----------------|------------------|----------------------------------|-------------|-----------|-----------|
| 2M805-003 | -01 | ZNU | 5-3 | P | A | |

| 1. SERIES | | |
|-------------|-------------------------------|--|
| Type | Part # | Description |
| CRIMP | PLUG | |
| | 2M805-001 | Plug with Banding Platform |
| | 2M805-002 | Plug with Accessory Threads |
| | RECEPTACLE | |
| | 2M805-003 | Receptacle with Banding Platform |
| PCB/ SOLDER | STRAIGHT PCB/SOLDER | |
| | 2M805-005 | Receptacle w/ Epoxy Potting |
| | 2M805-017 | Receptacle for Open Face Immersion |
| | 2M805-067 | Receptacle with Standoff Flange for Mechanical PCB Strain Relief |
| | RIGHT ANGLE PCB | |
| 2M805-011 | Receptacle w/ Right Angle PCB | |

| 2. SHELL STYLE | |
|----------------------------|--|
| Part # | Description |
| PLUG | |
| -16 | Self-Locking Plug with Ratchet mechanism |
| RECEPTACLE | |
| -01 | In-Line Receptacle |
| -02 | Square Flange Receptacle |
| -07 | Jam Nut* Receptacle |
| STRAIGHT PCB/SOLDER | |
| -02 | Square Flange Receptacle |
| -07 | Jam Nut* Receptacle |
| RIGHT ANGLE | |
| -07 | Jam Nut* Receptacle |

*add "-501" as a suffix to the Jam Nut Part number to include a Hex Nut instead of a Spanner Nut.

| 3. SERVICE CLASS | | | |
|------------------|--------|---------------------------|------|
| Material | Part # | Description | RoHS |
| ALUMINUM | C | Anodized (Non-conductive) | |
| | M | Electroless Nickel | |
| | NF | Olive Drab Cadmium | |
| | MT | Durmalon (Ni PTFE) | |
| | ZN | Olive Drab Zinc Nickel | |
| | ZNU | Black Zinc Nickel | |
| | BEN | Black Electroless Nickel | |
| STAINLESS STEEL | Z1 | Passivated | |
| | ZL | Electrolytic Nickel | |



4. SHELL SIZE-INSERT ARRANGEMENT

See Table on pages 7-20

| 5. CONTACTS | | |
|-------------|--------|----------------------|
| Style | Part # | Description |
| CRIMP | P | Pin |
| | S | Socket |
| | A | Pin-Less Contacts |
| | B | Socket-Less Contacts |

| 5. CONTACTS | | |
|----------------------|--------|-------------------|
| STRAIGHT/RIGHT ANGLE | | |
| Style | Part # | Description |
| PCB/ SOLDER | P | Pin-PCB |
| | S | Socket-PCB |
| | E | Pin-Solder Cup |
| | F | Socket-Solder Cup |

| 6. KEYING | | |
|-----------|------|------|
| Part # | A° | B° |
| A | 150° | 210° |
| B | 75° | 210° |
| C | 95° | 230° |
| D | 140° | 275° |

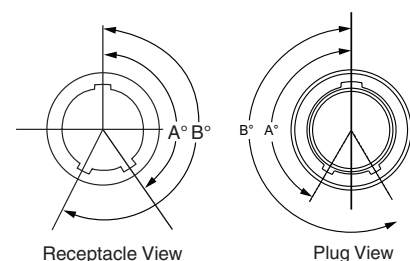

For additional assistance building a part number and for 3D models, please visit www.amphenol-aerospace.com to access our 2M configurator.

2M805 High Speed Tri-Start Threaded Coupling

Ordering Guide for High Speed 2M805 Plugs & Receptacles

The 2M805 High Speed Series of connectors is ideal for use in USB 3.0, eSATA and other high speed databus applications where space is limited. These connectors utilize Fluoropolymer inserts that are optimized for high speed capability. Multiple standard insert arrangements are available. This series features self-locking plugs with a ratcheting mechanism and a Tri-Start ACME thread that provides full mating in one turn. Plugs and receptacles are each available in two shell styles. The integral banding platform allows for direct termination of EMI shielding attachments and also allows for overmolding. Rear threads are also available for the attachment of backshells and other accessories. Contact termination styles include Crimp, PC Tail and Solder Cup.

2M805

| 1. SERIES | 2. SHELL STYLE | 3. SERVICE CLASS | 4. SHELL SIZE INSERT ARRANGEMENT | 5. CONTACTS | 6. KEYING |
|-----------|----------------|------------------|----------------------------------|-------------|-----------|
| 2M805-020 | -16 | ZNU | 9-10 | P | A |

| 1. SERIES | | |
|-----------|-----------------------------------|----------------------------------|
| Type | Part # | Description |
| CRIMP | PLUG | |
| | 2M805-020 | Plug with Banding Platform |
| | 2M805-021 | Plug with Accessory Threads |
| | RECEPTACLE | |
| | 2M805-022 | Receptacle with Banding Platform |
| 2M805-023 | Receptacle with Accessory Threads | |

| 2. SHELL STYLE | |
|-------------------|--|
| Part # | Description |
| PLUG | |
| -16 | Self-Locking Plug with Ratchet mechanism |
| RECEPTACLE | |
| -01 | In-Line Receptacle |
| -02 | Square Flange Receptacle |
| -12 | Square Flange Rear Mount Non-Locking Clinch Nuts |
| -22 | Square Flange Rear Mount Locking Clinch Nuts |
| -07 | Jam Nut* Receptacle |

| 3. SERVICE CLASS | | | |
|------------------|--------|--------------------|------|
| Material | Part # | Description | RoHS |
| ALUMINUM | M | Electroless Nickel | |
| | NF | Olive Drab Cadmium | |
| | MT | Durmalon (Ni PTFE) | |
| | ZNU | Black Zinc Nickel | |
| STAINLESS STEEL | Z1 | Passivated | |

| 4. SHELL SIZE-INSERT ARRANGEMENT | |
|----------------------------------|--|
| 9-10 | |
| 11-19 | |
| 12-26 | |

*add "-501" as a suffix to the Jam Nut Part number to include a Hex Nut instead of a Spanner Nut.

| 5. CONTACTS | | |
|-------------|--------|----------------------|
| Style | Part # | Description |
| CRIMP | P | Pin |
| | S | Socket |
| | A | Pin-Less Contacts |
| | B | Socket-Less Contacts |

| 6. KEYING | | |
|-----------|------|------|
| Part # | A° | B° |
| A | 150° | 210° |
| B | 75° | 210° |
| C | 95° | 230° |
| D | 140° | 275° |

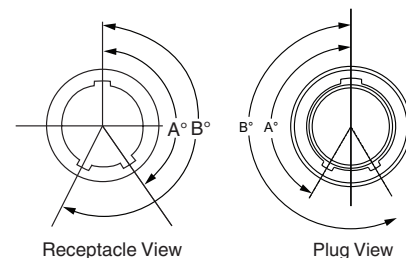

For additional assistance building a part number and for 3D models, please visit www.amphenol-aerospace.com to access our 2M configurator.

2M805 Tri-Start Threaded Coupling

Connector Weight in Grams



SERIES 2M805 CONNECTOR WEIGHT IN GRAMS

| Insert Arrange | Cable Plug | J/N Recept. Crimp | J/N Recept. PCB | Sq. Flange Recept. Crimp | Sq. Flange Recept. PCB |
|----------------|------------|-------------------|-----------------|--------------------------|------------------------|
| 8-1P | 7.5 | 5.8 | 5.7 | 5.8 | 4.6 |
| 8-1S | 7.9 | 6.3 | 6.2 | 6.3 | 5.1 |
| 8-4P | 8.3 | 6.6 | 6.5 | 6.6 | 5.4 |
| 8-4S | 8.8 | 7.2 | 7.0 | 7.2 | 5.9 |
| 8-7P | 7.3 | 5.6 | 5.5 | 5.6 | 4.4 |
| 8-7S | 7.7 | 6.1 | 5.9 | 6.1 | 4.8 |
| 9-1P | 10.9 | 9.0 | 9.0 | 6.8 | 7.7 |
| 9-1S | 11.4 | 9.6 | 9.6 | 7.4 | 8.3 |
| 9-10P | 10.7 | 8.8 | 8.8 | 6.6 | 7.5 |
| 9-10S | 11.6 | 9.7 | 9.7 | 7.5 | 8.4 |
| 10-2P | 13.3 | 10.2 | 10.3 | 8.9 | 9.4 |
| 10-2S | 14.1 | 11.0 | 11.1 | 9.7 | 10.1 |
| 10-13P | 12.7 | 9.6 | 9.7 | 8.3 | 8.7 |
| 10-13S | 13.4 | 10.3 | 10.5 | 9.0 | 9.5 |
| 10-200P | 13.9 | 10.8 | 10.9 | 9.5 | 9.9 |
| 10-200S | 14.7 | 11.7 | 11.8 | 10.3 | 10.8 |
| 11-4P | 15.4 | 12.1 | 13.1 | 10.3 | 11.3 |
| 11-4S | 16.4 | 13.1 | 14.1 | 11.3 | 12.3 |
| 11-19P | 14.3 | 11.0 | 12.0 | 9.2 | 10.2 |
| 11-19S | 15.4 | 12.1 | 13.1 | 10.3 | 11.3 |
| 11-200P | 14.9 | 11.6 | 12.5 | 9.8 | 10.8 |
| 11-200S | 16.0 | 12.7 | 13.6 | 10.9 | 11.9 |
| 11-201P | 15.4 | 12.1 | 13.1 | 10.3 | 11.3 |
| 11-201S | 16.6 | 13.3 | 14.3 | 11.6 | 12.5 |
| 12-5P | 17.6 | 13.9 | 16.3 | 12.2 | 13.1 |
| 12-5S | 19.0 | 15.3 | 17.7 | 13.6 | 14.5 |
| 12-26P | 15.8 | 12.1 | 14.5 | 10.5 | 11.3 |
| 12-26S | 17.4 | 13.6 | 16.1 | 12.0 | 12.9 |
| 12-200P | 16.5 | 12.8 | 15.2 | 11.1 | 12.0 |
| 12-200S | 17.9 | 14.2 | 16.6 | 12.5 | 13.4 |
| 12-201P | 16.6 | 12.9 | 15.3 | 11.2 | 12.1 |
| 12-201S | 18.0 | 14.3 | 16.7 | 12.7 | 13.5 |

SERIES 2M805 CONNECTOR WEIGHT IN GRAMS

| Insert Arrange | Cable Plug | J/N Recept. Crimp | J/N Recept. PCB | Sq. Flange Recept. Crimp | Sq. Flange Recept. PCB |
|----------------|------------|-------------------|-----------------|--------------------------|------------------------|
| 12-202P | 16.6 | 12.9 | 15.3 | 11.2 | 12.1 |
| 12-202S | 18.2 | 14.4 | 16.8 | 12.8 | 13.6 |
| 15-2P | 20.7 | 20.2 | 21.8 | 17.1 | 19.5 |
| 15-2S | 22.3 | 21.9 | 23.4 | 18.7 | 21.1 |
| 15-3P | 21.7 | 21.2 | 22.8 | 18.0 | 20.5 |
| 15-3S | 23.4 | 23.0 | 24.5 | 19.8 | 22.2 |
| 15-7P | 21.9 | 21.5 | 23.0 | 18.3 | 20.7 |
| 15-7S | 24.5 | 24.1 | 25.6 | 20.9 | 23.3 |
| 15-37P | 20.1 | 19.7 | 21.2 | 16.5 | 18.9 |
| 15-37S | 23.0 | 22.6 | 24.1 | 19.4 | 21.8 |
| 15-200P | 20.4 | 19.9 | 21.5 | 16.7 | 19.1 |
| 15-200S | 22.6 | 22.1 | 23.7 | 18.9 | 21.3 |
| 15-201P | 20.7 | 20.2 | 21.8 | 17.1 | 19.5 |
| 15-201S | 23.0 | 22.6 | 24.1 | 19.4 | 21.8 |
| 18-5P | 29.9 | 31.6 | 30.1 | 26.1 | 29.0 |
| 18-5S | 32.9 | 34.5 | 33.1 | 29.0 | 32.0 |
| 18-12P | 30.7 | 32.3 | 30.9 | 26.8 | 29.8 |
| 18-12S | 34.3 | 36.0 | 34.5 | 30.5 | 33.4 |
| 18-55P | 27.3 | 28.9 | 27.5 | 23.4 | 26.4 |
| 18-55S | 30.7 | 32.3 | 30.9 | 26.8 | 29.8 |
| 19-7P | 27.9 | 30.0 | 33.1 | 25.1 | 33.0 |
| 19-7S | 31.0 | 33.1 | 36.2 | 28.2 | 36.1 |
| 19-14P | 32.9 | 35.0 | 38.1 | 30.0 | 38.0 |
| 19-14S | 32.6 | 34.7 | 37.7 | 29.7 | 37.6 |
| 19-85P | 26.6 | 28.7 | 31.8 | 23.8 | 31.7 |
| 19-85S | 31.1 | 33.2 | 36.3 | 28.3 | 36.2 |
| 23-17P | 40.2 | 42.9 | 44.4 | 36.7 | 43.9 |
| 23-12S | 45.2 | 48.0 | 49.5 | 41.8 | 49.0 |
| 23-22P | 42.7 | 45.4 | 47.0 | 39.3 | 46.4 |
| 23-22S | 49.6 | 52.4 | 53.9 | 46.2 | 53.4 |
| 23-130P | 37.8 | 40.6 | 42.1 | 34.4 | 41.6 |
| 23-130S | 44.9 | 47.7 | 49.3 | 41.6 | 48.7 |

2M805

C

2M805 Tri-Start Plug

2M805-001 and 2M805-002

2M805

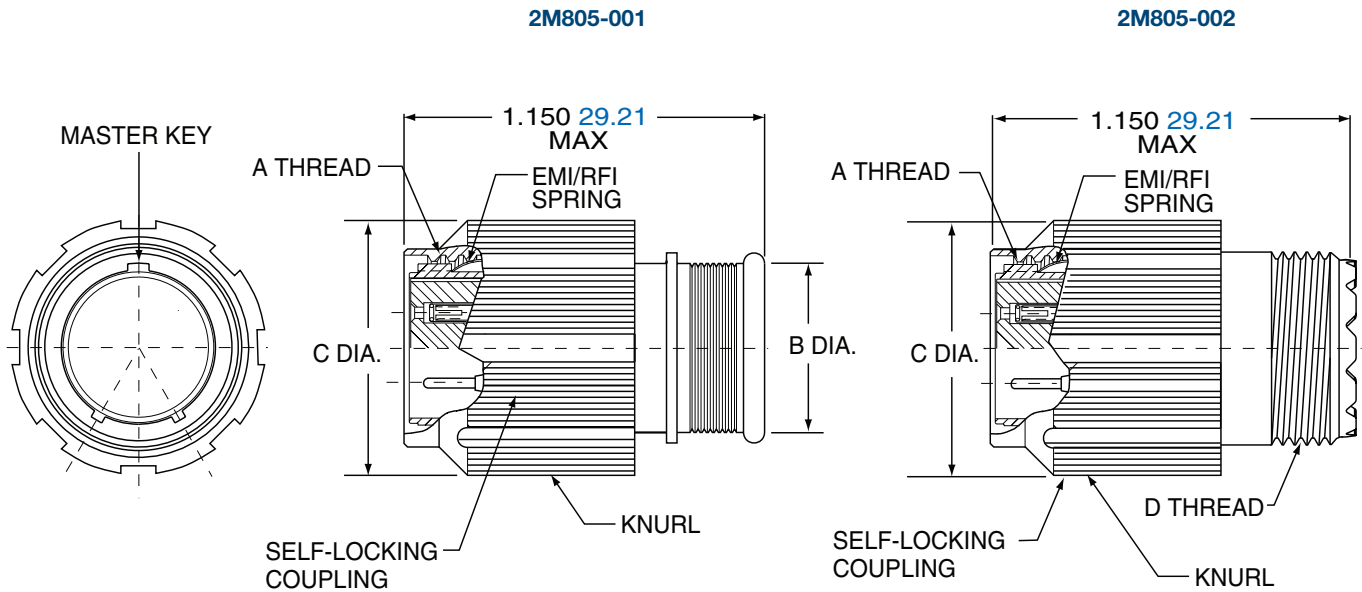

| Shell Size | A Threads | B Dia. | | C Dia. | | D Threads Accessory |
|------------|----------------------|--------|-------|--------|-------|---------------------|
| | | in. | mm. | in. | mm. | |
| 8 | .5000-.1P-.3L-TS-2B | .317 | 8.05 | .691 | 17.55 | .3750-32 UNEF-2A |
| 9 | .5625-.1P-.3L-TS-2B | .397 | 10.08 | .787 | 19.99 | .4375-28 UNEF-2A |
| 10 | .6250-.1P-.3L-TS-2B | .473 | 12.01 | .826 | 20.98 | .5000-28 UNEF-2A |
| 11 | .6875-.1P-.3L-TS-2B | .519 | 13.18 | .925 | 23.50 | .5625-24 UNEF-2A |
| 12 | .7500-.1P-.3L-TS-2B | .585 | 14.86 | .982 | 24.94 | .6250-24 UNEF-2A |
| 15 | .9375-.1P-.3L-TS-2B | .687 | 17.45 | 1.105 | 28.07 | .7500-20 UNEF-2A |
| 18 | 1.1250-.1P-.3L-TS-2B | .884 | 22.45 | 1.275 | 32.39 | .9375-20 UNEF-2A |
| 19 | 1.1875-.1P-.3L-TS-2B | .884 | 22.45 | 1.310 | 33.27 | .9375-20 UNEF-2A |
| 23 | 1.4375-.1P-.3L-TS-2B | 1.135 | 28.83 | 1.562 | 39.67 | 1.1875-18 UNEF-2A |

2M805 Tri-Start In-Line Receptacle

2M805-003-01 and 2M805-004-01

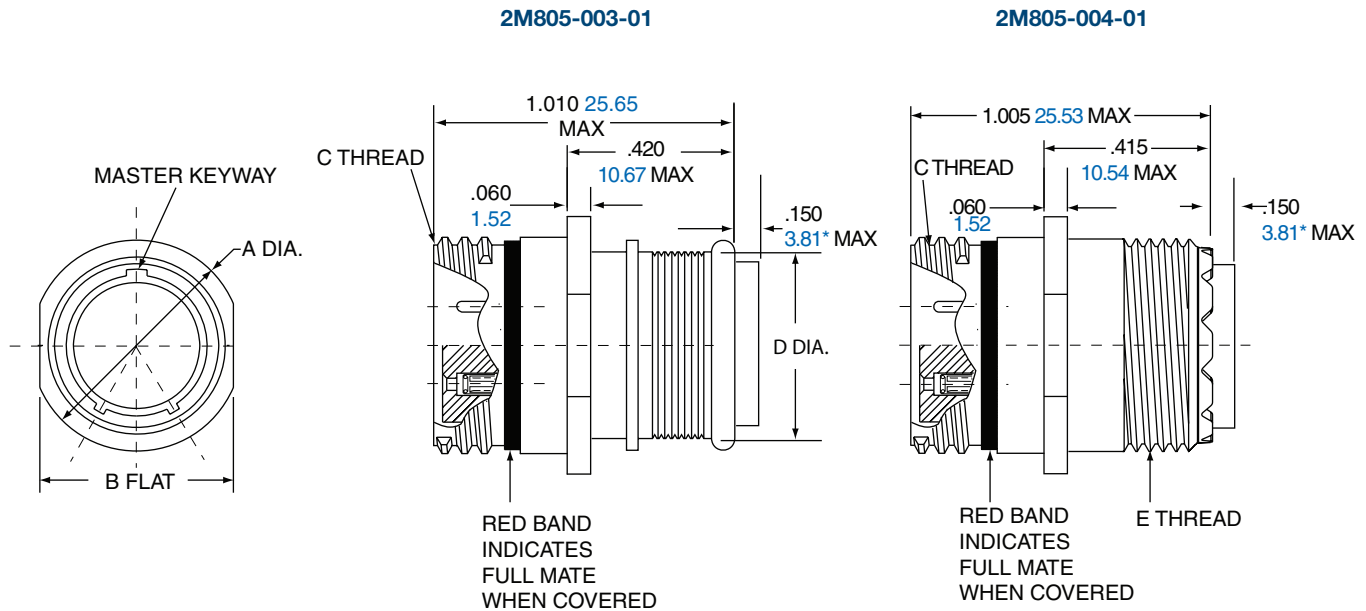

* Grommet protrudes for power/combo arrangement

| Shell Size | A Dia. | | B Flat | | C Threads | D Dia. | | E Threads Accessory |
|------------|--------|-------|--------|-------|----------------------|--------|-------|---------------------|
| | in. | mm. | in. | mm. | | in. | mm. | |
| 8 | .543 | 13.79 | .513 | 13.03 | .5000-.1P-.3L-TS-2A | .317 | 8.05 | .3750-32 UNEF-2A |
| 9 | .608 | 15.44 | .578 | 14.68 | .5625-.1P-.3L-TS-2A | .397 | 10.08 | .4375-28 UNEF-2A |
| 10 | .671 | 17.04 | .641 | 16.28 | .6250-.1P-.3L-TS-2A | .473 | 12.01 | .5000-28 UNEF-2A |
| 11 | .733 | 18.62 | .703 | 17.86 | .6875-.1P-.3L-TS-2A | .519 | 13.18 | .5625-24 UNEF-2A |
| 12 | .796 | 20.22 | .766 | 19.46 | .7500-.1P-.3L-TS-2A | .585 | 14.86 | .6250-24 UNEF-2A |
| 15 | .983 | 24.97 | .953 | 24.21 | .9375-.1P-.3L-TS-2A | .687 | 17.45 | .7500-20 UNEF-2A |
| 18 | 1.168 | 29.67 | 1.138 | 28.91 | 1.1250-.1P-.3L-TS-2A | .884 | 22.45 | .9375-20 UNEF-2A |
| 19 | 1.238 | 31.45 | 1.208 | 30.68 | 1.1875-.1P-.3L-TS-2A | .884 | 22.45 | .9375-20 UNEF-2A |
| 23 | 1.485 | 37.72 | 1.455 | 39.96 | 1.4375-.1P-.3L-TS-2A | 1.135 | 28.83 | 1.1875-18 UNEF-2A |

2M805

C

2M805 Tri-Start Square Flange Receptacle

2M805-003-02 and 2M805-004-02

2M805

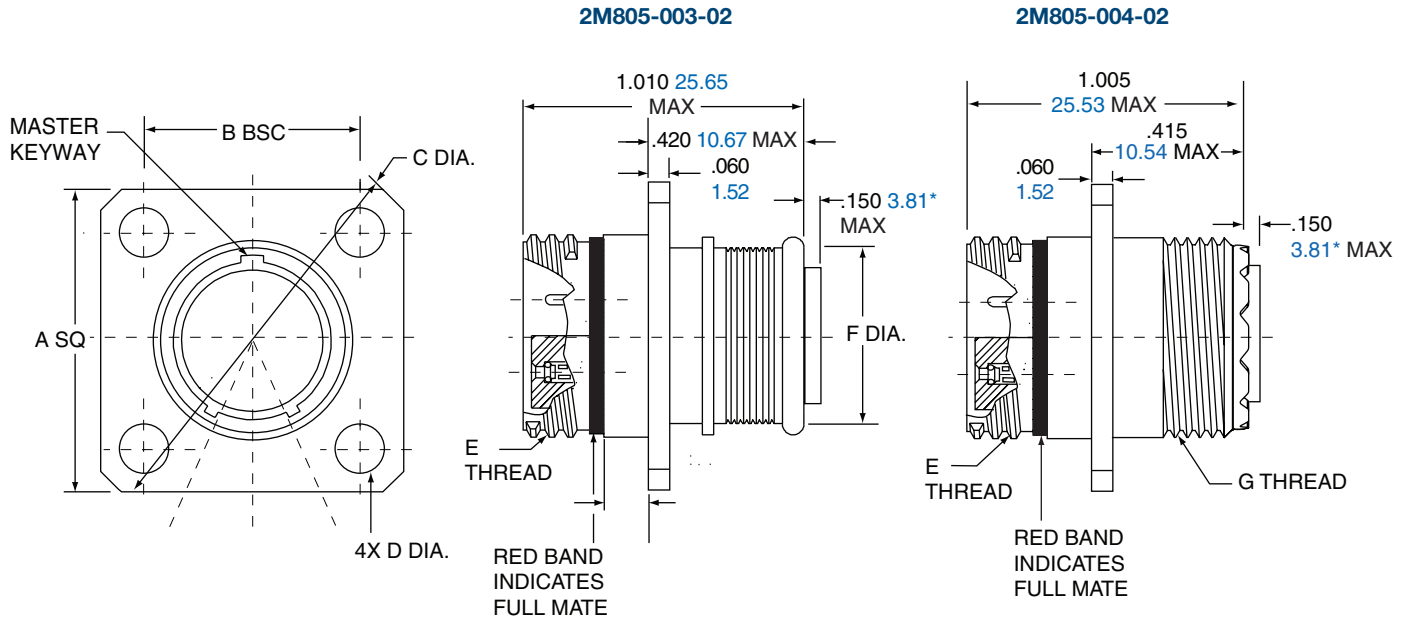

* Grommet protrudes for power/combo arrangement

| Shell Size | A Sq. | | B BSC. | | C Dia. | | D Dia. | | E Threads | F Dia. | | G Threads Accessory |
|------------|-------|-------|--------|-------|--------|-------|-----------|----------|----------------------|--------|-------|---------------------|
| | in. | mm. | in. | mm. | in. | mm. | in. ±.003 | mm. ±.08 | | in. | mm. | |
| 8 | .853 | 21.67 | .660 | 16.76 | 1.153 | 29.29 | .091 | 2.31 | .5000-.1P-.3L-TS-2A | .317 | 8.05 | .3750-32 UNEF-2A |
| 9 | .916 | 23.27 | .723 | 18.36 | 1.233 | 31.32 | .091 | 2.31 | .5625-.1P-.3L-TS-2A | .397 | 10.08 | .4375-28 UNEF-2A |
| 10 | .978 | 24.84 | .785 | 19.94 | 1.333 | 33.86 | .091 | 2.31 | .6250-.1P-.3L-TS-2A | .473 | 12.01 | .5000-28 UNEF-2A |
| 11 | 1.042 | 26.47 | .848 | 21.54 | 1.413 | 35.89 | .091 | 2.31 | .6875-.1P-.3L-TS-2A | .519 | 13.18 | .5625-24 UNEF-2A |
| 12 | 1.102 | 27.99 | .909 | 23.09 | 1.503 | 38.18 | .091 | 2.31 | .7500-.1P-.3L-TS-2A | .585 | 14.86 | .6250-24 UNEF-2A |
| 15 | 1.291 | 32.79 | 1.058 | 26.87 | 1.753 | 44.53 | .125 | 3.18 | .9375-.1P-.3L-TS-2A | .687 | 17.45 | .7500-20 UNEF-2A |
| 18 | 1.478 | 37.54 | 1.255 | 31.88 | 2.003 | 50.88 | .125 | 3.18 | 1.1250-.1P-.3L-TS-2A | .884 | 22.45 | .9375-20 UNEF-2A |
| 19 | 1.540 | 39.12 | 1.327 | 33.71 | 2.097 | 53.26 | .125 | 3.18 | 1.1875-.1P-.3L-TS-2A | .884 | 22.45 | .9375-20 UNEF-2A |
| 23 | 1.790 | 45.47 | 1.570 | 39.88 | 2.443 | 62.05 | .125 | 3.18 | 1.4375-.1P-.3L-TS-2A | 1.135 | 28.83 | 1.1875-18 UNEF-2A |

2M805 Tri-Start Jam Nut Receptacle

2M805-003-07 and 2M805-004-07

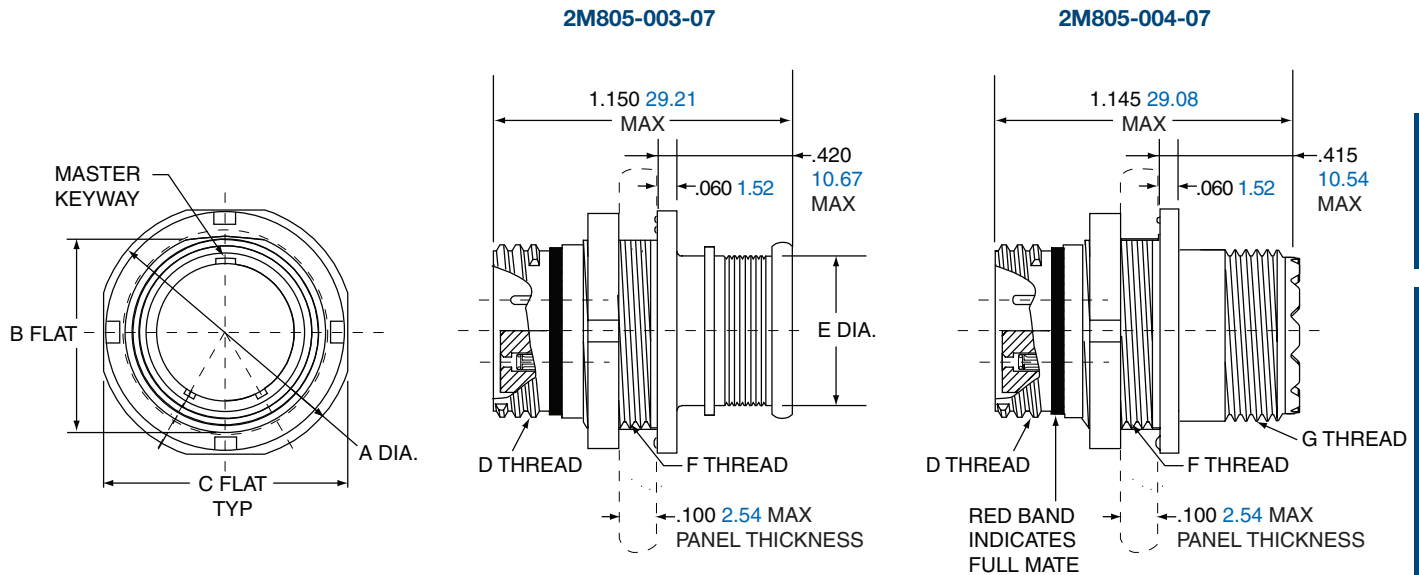

| Shell Size | A Dia. | | B Flat | | C Flat | | D Threads | E Dia. | | F Threads | G Threads Accessory |
|------------|--------|-------|--------|-------|--------|-------|----------------------|--------|-------|-----------------|---------------------|
| | in. | mm. | in. | mm. | in. | mm. | | in. | mm. | | |
| 8 | .760 | 19.30 | .535 | 13.59 | .730 | 18.54 | .5000-.1P-.3L-TS-2A | .317 | 8.05 | .5625-28 UN-2A | .3750-32 UNEF-2A |
| 9 | .880 | 22.35 | .661 | 16.79 | .850 | 21.59 | .5625-.1P-.3L-TS-2A | .397 | 10.08 | .6875-28 UN-2A | .4375-28 UNEF-2A |
| 10 | .880 | 22.35 | .661 | 16.79 | .850 | 21.59 | .6250-.1P-.3L-TS-2A | .473 | 12.01 | .6875-28 UN-2A | .5000-28 UNEF-2A |
| 11 | .955 | 24.26 | .721 | 18.31 | .925 | 23.50 | .6875-.1P-.3L-TS-2A | .519 | 13.18 | .7500-28 UN-2A | .5625-24 UNEF-2A |
| 12 | 1.065 | 27.05 | .784 | 19.91 | 1.039 | 26.39 | .7500-.1P-.3L-TS-2A | .585 | 14.86 | .8125-28 UN-2A | .6250-24 UNEF-2A |
| 15 | 1.203 | 30.56 | .970 | 24.64 | 1.173 | 29.79 | .9375-.1P-.3L-TS-2A | .687 | 17.45 | 1.0000-28 UN-2A | .7500-20 UNEF-2A |
| 18 | 1.395 | 35.43 | 1.150 | 29.21 | 1.359 | 34.52 | 1.1250-.1P-.3L-TS-2A | .884 | 22.45 | 1.1875-28 UN-2A | .9375-20 UNEF-2A |
| 19 | 1.450 | 36.83 | 1.221 | 31.01 | 1.420 | 36.07 | 1.1875-.1P-.3L-TS-2A | .884 | 22.45 | 1.2500-28 UN-2A | .9375-20 UNEF-2A |
| 23 | 1.705 | 43.31 | 1.470 | 37.34 | 1.678 | 42.62 | 1.4375-.1P-.3L-TS-2A | 1.135 | 28.83 | 1.5000-28 UN-2A | 1.1875-18 UNEF-2A |

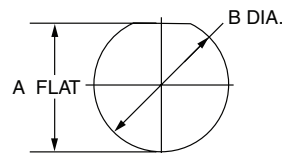

| PANEL CUTOUT FOR JAM NUT | | | | |
|--------------------------|-----------|------------|-----------|------------|
| Shell Size | A Flat | | B Dia | |
| | in. ±.002 | mm. ± 0.05 | in. ±.005 | mm. ± 0.13 |
| 8 | .543 | 13.79 | .572 | 14.53 |
| 9 | .669 | 16.99 | .698 | 17.73 |
| 10 | .669 | 16.99 | .698 | 17.73 |
| 11 | .729 | 18.51 | .760 | 19.30 |
| 12 | .792 | 20.17 | .822 | 20.88 |
| 15 | .978 | 24.84 | 1.010 | 25.65 |
| 18 | 1.155 | 29.34 | 1.198 | 30.43 |
| 19 | 1.231 | 31.27 | 1.260 | 32.00 |
| 23 | 1.480 | 37.59 | 1.510 | 38.35 |

2M805 Tri-Start PC Tail, Solder Cup Square Flange

2M805-005-02 and 2M805-017-02

2M805-005-02
2M805-017-02

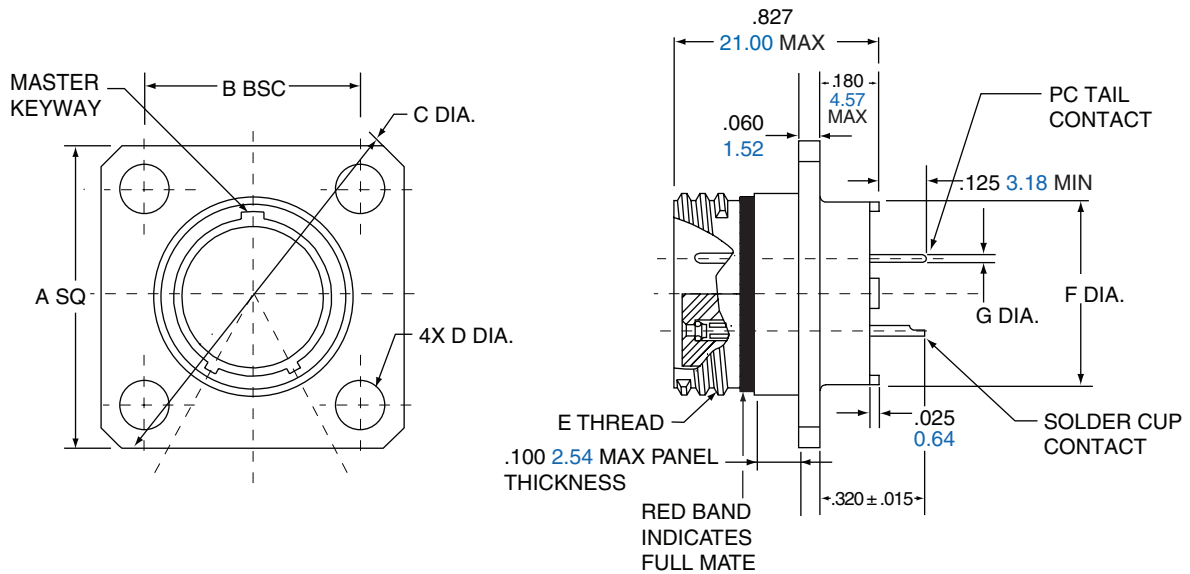

| Shell Size | A Sq. | | B BSC. | | C Dia. | | D Dia. | | E Threads | F Dia. | | G PC Tail Dia. |
|------------|-------|-------|--------|-------|--------|-------|--------------|-------------|----------------------|--------|-------|----------------------|
| | in. | mm. | in. | mm. | in. | mm. | in. ±.003 | mm. ±.08 | | in. | mm. | |
| 8 | .853 | 21.67 | .660 | 16.76 | 1.153 | 29.29 | .091 | 2.31 | .5000-.1P-.3L-TS-2A | .330 | 8.38 | #23 |
| 9 | .916 | 23.27 | .723 | 18.36 | 1.233 | 31.32 | .091 | 2.31 | .5625-.1P-.3L-TS-2A | .432 | 10.97 | .018/.022 0.46/0.56 |
| 10 | .978 | 24.84 | .785 | 19.94 | 1.333 | 33.86 | .091 | 2.31 | .6250-.1P-.3L-TS-2A | .493 | 12.52 | #20/20HD |
| 11 | 1.042 | 26.47 | .848 | 21.54 | 1.413 | 35.89 | .091 | 2.31 | .6875-.1P-.3L-TS-2A | .551 | 14.00 | .025/.027 0.64/0.69 |
| 12 | 1.102 | 27.99 | .909 | 23.09 | 1.503 | 38.18 | .091 | 2.31 | .7500-.1P-.3L-TS-2A | .620 | 15.78 | #16 |
| 15 | 1.291 | 32.79 | 1.058 | 26.87 | 1.753 | 44.53 | .125 | 3.18 | .9375-.1P-.3L-TS-2A | .703 | 17.86 | .060/.064 1.521/1.63 |
| 18 | 1.478 | 37.54 | 1.255 | 31.88 | 2.003 | 50.88 | .125 | 3.18 | 1.1250-.1P-.3L-TS-2A | .863 | 21.92 | #12 |
| 19 | 1.540 | 39.12 | 1.327 | 33.71 | 2.097 | 53.26 | .125 | 3.18 | 1.1875-.1P-.3L-TS-2A | .912 | 23.16 | .092/.096 2.34/2.44 |
| 23 | 1.790 | 45.47 | 1.570 | 39.88 | 2.443 | 62.05 | .125 | 3.18 | 1.4375-.1P-.3L-TS-2A | 1.162 | 29.51 | |

2M805 Tri-Start PC Tail, Solder Cup Jam Nut

2M805-005-07 and 2M805-017-07



2M805-005-07
2M805-017-07

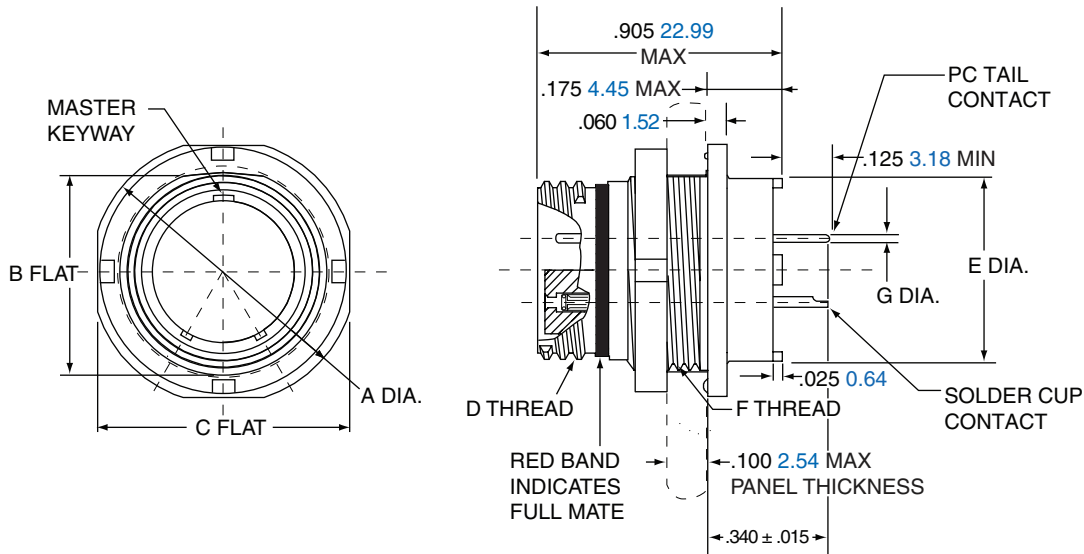

| Shell Size | A Dia. | | B Flat | | C Flat | | D Threads | E Dia. | | F Threads | G PC Tail Dia. |
|------------|--------|-------|--------|-------|--------|-------|----------------------|--------|-------|-----------------|------------------------------------|
| | in. | mm. | in. | mm. | in. | mm. | | in. | mm. | | |
| 8 | .760 | 19.30 | .535 | 13.59 | .730 | 18.54 | .5000-.1P-.3L-TS-2A | .330 | 8.38 | .5625-28 UN-2A | #23 .018/.022 0.46/0.56 |
| 9 | .880 | 22.35 | .661 | 16.79 | .850 | 21.59 | .5625-.1P-.3L-TS-2A | .432 | 10.97 | .6875-28 UN-2A | #20/20HD .025/.027 0.64/0.69 |
| 10 | .880 | 22.35 | .661 | 16.79 | .850 | 21.59 | .6250-.1P-.3L-TS-2A | .493 | 12.52 | .6875-28 UN-2A | |
| 11 | .955 | 24.26 | .721 | 18.31 | .925 | 23.50 | .6875-.1P-.3L-TS-2A | .551 | 14.00 | .7500-28 UN-2A | #16 .060/.064 1.521/1.63 |
| 12 | 1.060 | 26.92 | .784 | 19.91 | 1.035 | 26.29 | .7500-.1P-.3L-TS-2A | .620 | 15.78 | .8125-28 UN-2A | |
| 15 | 1.203 | 30.56 | .970 | 24.64 | 1.173 | 29.79 | .9375-.1P-.3L-TS-2A | .703 | 17.86 | 1.0000-28 UN-2A | #12 .092/.096 2.34/2.44 |
| 18 | 1.395 | 35.43 | 1.150 | 29.21 | 1.359 | 34.52 | 1.1250-.1P-.3L-TS-2A | .863 | 21.92 | 1.1875-28 UN-2A | |
| 19 | 1.450 | 36.83 | 1.221 | 31.01 | 1.420 | 36.07 | 1.1875-.1P-.3L-TS-2A | .912 | 23.16 | 1.2500-28 UN-2A | |
| 23 | 1.705 | 43.31 | 1.470 | 37.34 | 1.675 | 42.55 | 1.4375-.1P-.3L-TS-2A | 1.162 | 29.51 | 1.5000-28 UN-2A | |

| PANEL CUTOUT FOR JAM NUT | | | | |
|--------------------------|--------------|---------------|--------------|---------------|
| Shell Size | A Flat | | B Dia | |
| | in. ±.002 | mm. ± 0.05 | in. ±.005 | mm. ± 0.13 |
| 8 | .543 | 13.79 | .572 | 14.53 |
| 9 | .669 | 16.99 | .698 | 17.73 |
| 10 | .669 | 16.99 | .698 | 17.73 |
| 11 | .729 | 18.51 | .760 | 19.30 |
| 12 | .792 | 20.17 | .822 | 20.88 |
| 15 | .978 | 24.84 | 1.010 | 25.65 |
| 18 | 1.155 | 29.34 | 1.198 | 30.43 |
| 19 | 1.231 | 31.27 | 1.260 | 32.00 |
| 23 | 1.480 | 37.59 | 1.510 | 38.35 |

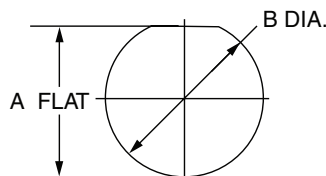

2M805 PCB Standoff Double Flange

2M805-067-07

2M805

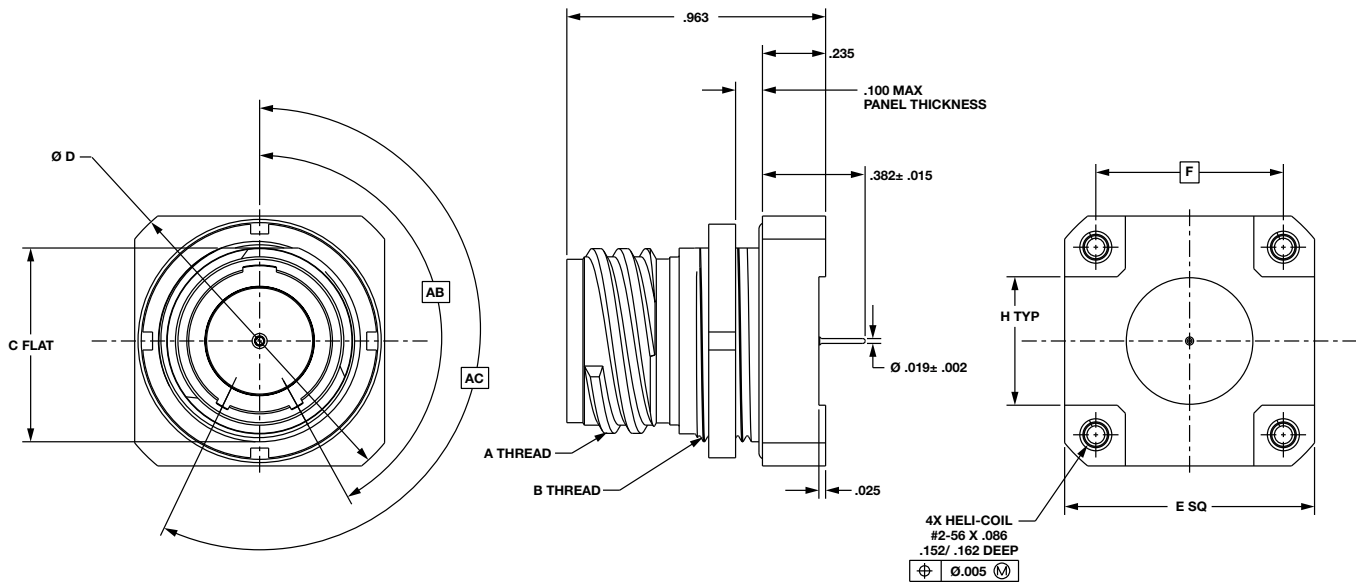

| Shell Size | A Threads | B Threads | C Flat | | D Dia. | | E SQ | | F | | H Typ | |
|------------|----------------------|-----------------|--------|-------|--------|-------|-------|-------|-------|-------|-------|-------|
| | | | in. | mm. | in. | mm. | in. | mm. | in. | mm. | in. | mm. |
| 8 | .5000-.1P-.3L-TS-2A | .5625-28 UN-2A | .535 | 13.59 | .923 | 23.44 | .732 | 18.59 | .496 | 12.60 | .273 | 6.93 |
| 9 | .5625-.1P-.3L-TS-2A | .6875-28 UN-2A | .661 | 16.79 | 1.113 | 28.27 | .862 | 21.89 | .627 | 15.93 | .404 | 10.26 |
| 10 | .6250-.1P-.3L-TS-2A | .6875-28 UN-2A | .661 | 16.79 | 1.113 | 28.27 | .862 | 21.89 | .627 | 15.93 | .404 | 10.26 |
| 11 | .6875-.1P-.3L-TS-2A | .7500-28 UN-2A | .721 | 18.31 | 1.203 | 30.55 | .933 | 23.70 | .698 | 17.73 | .475 | 12.06 |
| 12 | .7500-.1P-.3L-TS-2A | .8125-28 UN-2A | .784 | 19.91 | 1.373 | 34.87 | 1.047 | 26.59 | .812 | 20.62 | .589 | 14.96 |
| 15 | .9375-.1P-.3L-TS-2A | 1.0000-28 UN-2A | .970 | 24.64 | 1.563 | 39.70 | 1.178 | 29.92 | .943 | 23.95 | .720 | 18.28 |
| 18 | 1.1250-.1P-.3L-TS-2A | 1.1875-28 UN-2A | 1.147 | 29.13 | 1.803 | 45.79 | 1.354 | 34.39 | 1.119 | 28.42 | .896 | 22.75 |
| 19 | 1.1875-.1P-.3L-TS-2A | 1.2500-28 UN-2A | 1.221 | 31.01 | 1.883 | 47.83 | 1.410 | 35.81 | 1.175 | 29.84 | .952 | 24.18 |
| 23 | 1.4375-.1P-.3L-TS-2A | 1.5000-28 UN-2A | 1.470 | 37.34 | 2.273 | 57.73 | 1.683 | 42.75 | 1.448 | 36.78 | 1.225 | 31.11 |

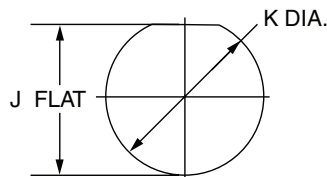

| Shell Size | PANEL CUTOUT | | | |
|------------|--------------|------------|-----------|------------|
| | A Flat | | B Dia | |
| | in. ±.002 | mm. ± 0.05 | in. ±.005 | mm. ± 0.13 |
| 8 | .543 | 13.79 | .572 | 14.53 |
| 9 | .669 | 16.99 | .698 | 17.73 |
| 10 | .669 | 16.99 | .698 | 17.73 |
| 11 | .729 | 18.51 | .760 | 19.30 |
| 12 | .792 | 20.17 | .822 | 20.88 |
| 15 | .978 | 24.84 | 1.010 | 25.65 |
| 18 | 1.155 | 29.34 | 1.198 | 30.43 |
| 19 | 1.231 | 31.27 | 1.260 | 32.00 |
| 23 | 1.480 | 37.59 | 1.510 | 38.35 |

2M805 Tri-Start Protection Cap

Ordering Guide for 2M667-261 and 2M667-262



2M805 Tri-Start Protection Caps are available in plug and receptacle versions. Protective caps keep the connector interface dry and clean while not in use. Caps come in a variety of materials, lanyard styles, and lengths to accommodate specific design requirements.



| 1. SERIES | 2. SERVICE CLASS | 3. ATTACHMENT TYPE | 4. SHELL SIZE | 5. ATTACHMENT CODE | 6. ATTACHMENT LENGTH IN INCHES |
|-----------|------------------|--------------------|---------------|--------------------|--------------------------------|
| 2M667-26X | -NF | -H | 9 | 04 | -5 |

| 1. SERIES | |
|-----------|--------------------------------------|
| Part # | Description |
| 2M667-261 | Protection Caps 2M805 Plugs |
| 2M667-262 | Protection Caps 2M805 Receptacles |

| 2. SERVICE CLASS | | | | | |
|------------------|--------|---------------------------------|------|--|--|
| Material | Part # | Description | RoHS | | |
| ALUMINUM | -C | Black Anodized (Non-conductive) | | | |
| | -M | Electroless Nickel | | | |
| | -NF | Olive Drab Cadmium | | | |
| | -MT | Durmalon (Ni PTFE) | | | |
| | -ZN | Olive Drab Zinc Nickel | | | |
| | -ZNU | Black Zinc Nickel | | | |
| STAINLESS STEEL | -Z1 | Passivated | | | |
| | -ZL | Electrolytic Nickel | | | |

| 3. ATTACHMENT TYPE | | |
|--------------------|--------|--|
| | Part # | Description |
| | -G | Nylon Rope |
| | -H | Stainless Steel Wire Rope, Teflon® Jacket |
| | -N | No Attachment |
| | -S | Stainless Steel Sash Chain |
| | -SK | Nylon Rope With Slip Knot |
| | -T | Stainless Steel Wire Rope, No Jacket |
| | -U | Stainless Steel Wire Rope, Polyurethane Jacket |

| 4. SHELL SIZE |
|---------------|
| Part # |
| 8 |
| 9 |
| 10 |
| 11 |
| 12 |
| 15 |
| 18 |
| 19 |
| 23 |

| 5. ATTACHMENT CODE | |
|--------------------|---|
| | Omit for attachment Types N (No Attachment) and SK (Slip Knot) For Shell Size |
| | 01 -.126 (3.20) I.D. |
| | 02 -.145 (3.68) I.D. |
| | 04 -.188 (4.78) I.D. |
| | 06 -.197 (5.00) I.D. |
| | 17 -.635 (16.13) I.D. 8 |
| | 18 -.695 (17.65) I.D. 9, 10 |
| | 19 -.885 (22.48) I.D. 12 |
| | 20 -1.070 (27.17) I.D. 15 |
| | 22 -1.210 (30.73) I.D. 18 |
| | 23 -1.275 (32.39) I.D. 19 |
| | 25 -1.530 (38.86) I.D. 23 |
| | 50 -.420 (10.67) I.D. |
| | 52 -.480 (12.19) I.D. |
| | 54 -.635 (16.13) I.D. |
| | 56 -.745 (18.92) I.D. |
| | 58 -.885 (22.48) I.D. |
| | 60 -1.010 (25.65) I.D. |
| | 64 -1.125 (28.58) I.D. |
| | 68 -1.345 (34.16) I.D. |

| 5. ADDITIONAL ATTACHMENT CODE | | |
|-------------------------------|-----------|---------------------|
| | | |
| | 14 | -.385 (9.78) I.D. |
| | 15 | -.445 (11.30) I.D. |
| | 16 | -.570 (14.48) I.D. |
| | 21 | -1.135 (38.86) I.D. |
| | 26 | -.950 (24.13) I.D. |
| | 27 | -.766 (19.46) I.D. |
| | 28 | -1.015 (25.78) I.D. |
| | 29 | -.315 (8.0) I.D. |
| | 30 | -1.380 (35.05) I.D. |
| | 31 | -.820 (20.83) I.D. |
| | 32 | -.265 (6.7) I.D. |
| | 33 | -.510 (12.95) I.D. |

| 6. ATTACHMENT LENGTH IN INCHES | |
|--------------------------------|--|
| -5 | Inch Length |
| | Omit for attachment Type N (No Attachment) Example "-5" equals five inch length |

Assembly Instructions for Protection Cap, see page 100.

2M805 Tri-Start Protection Cap

Metal Protective Caps 2M667-261 and 2M667-262

2M667-261

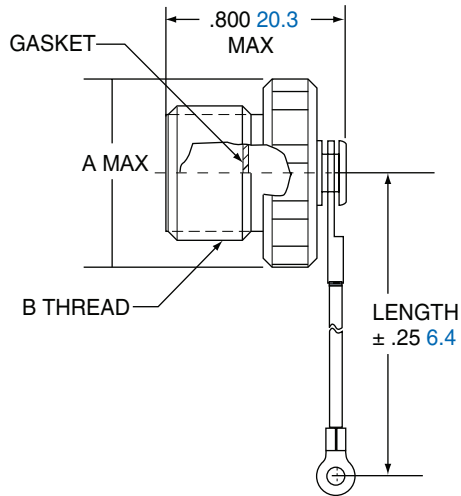

2M667-262

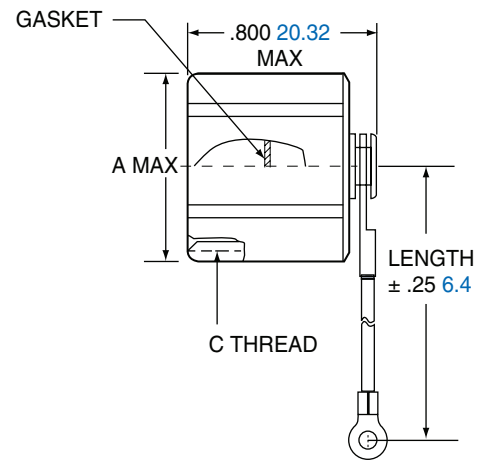

| Shell Size | A Max. | | B Thread | C Thread |
|------------|--------|-------|----------------------|----------------------|
| | in. | mm. | | |
| 8 | .656 | 16.66 | .5000-.1P-.3L-TS-2A | .5000-.1P-.3L-TS-2B |
| 9 | .718 | 18.24 | .5625-.1P-.3L-TS-2A | .5625-.1P-.3L-TS-2B |
| 10 | .781 | 19.84 | .6250-.1P-.3L-TS-2A | .6250-.1P-.3L-TS-2B |
| 11 | .844 | 21.44 | .6875-.1P-.3L-TS-2A | .6875-.1P-.3L-TS-2B |
| 12 | .906 | 23.01 | .7500-.1P-.3L-TS-2A | .7500-.1P-.3L-TS-2B |
| 15 | 1.094 | 27.79 | .9375-.1P-.3L-TS-2A | .9375-.1P-.3L-TS-2B |
| 18 | 1.281 | 32.54 | 1.1250-.1P-.3L-TS-2A | 1.1250-.1P-.3L-TS-2B |
| 19 | 1.343 | 34.11 | 1.1875-.1P-.3L-TS-2A | 1.1875-.1P-.3L-TS-2B |
| 23 | 1.603 | 40.72 | 1.4375-.1P-.3L-TS-2A | 1.4375-.1P-.3L-TS-2B |

MATERIALS AND FINISHES

| | |
|----------------|-----------------------------------|
| Cover | Aluminum alloy or stainless steel |
| Gasket | Fluorosilicone rubber |
| Wire, Hardware | Stainless steel, passivated |

2M804 Push-Pull Quick-Disconnect

General Information



Page Guide

| | |
|------------------------|--------|
| Order | D41 |
| Weight..... | D42 |
| Plugs..... | D43 |
| Jam Nut Rear..... | D44 |
| Jam Nut Front..... | D45 |
| In-Line..... | D46 |
| PCB/Jam Nut (R)..... | D47 |
| PCB/Jam Nut (F)..... | D48 |
| Panel Mt Plug..... | D49 |
| Jam Nut Panel Mt..... | D50 |
| Flange Mt Plug..... | D51 |
| PCB Double Flange..... | D52 |
| Protection Caps | D53-57 |

Amphenol's 2M Micro38999 Connector Series... The New Aerospace Standard

Averaging less than half the size and weight of their 38999 ancestors, Amphenol's 2M Micro38999 series are an easy and inexpensive way to take weight out of your system. 2M meet or exceed most environmental and performance requirements listed in MIL-DTL-38999, so modernizing your equipment doesn't mean sacrificing ruggedness. With almost 2,000,000 configurations in every termination style and a full complement of accessories available right out of the catalog, customization has never been easier. Smarter, faster and smaller: Amphenol's 2M... the only connector you'll ever need.

2M804 Features

- Push-pull coupling
- Excellent EMI shielding
- Rated to 38999 immersions
- Quick-disconnect



2M804

Why 2M804?

2M804 connectors are the most rugged push-pull connectors on the market. Designed for use in soldier-worn tactical equipment deployed by the United States military, these connectors were built to perform. Waterproof, dustproof, and highly resistant to EMI interference, these connectors are just as at home on the battlefield as they are in use on C4I and IFE systems. With up to 85 signals, panel-mounting options, and customizable separation forces, there's no place on land, sea, or air 2M804 can't go.

| 2M804 VS 38999 | | |
|-----------------------------|--|--|
| Specification | 2M804 | MIL-DTL 38999 Series III |
| Signal Count | 1 to 85 | 1 to 187 |
| Insulation Resistance | 5,000 megaohms min | 5,000 megaohms min |
| Operating Temperature | -65°C to +175°C | -65°C to +175°C |
| Shock | 300 G ± 15 | 300 G ± 15 |
| Vibration | "37.0 G Random 30.0 G Sine" | "43.9 G Random 60.0 G Sine" |
| Shielding Effectiveness | "40 dB min. from 100 MHz to 1000 MHz" | "65 dB min. from 100 MHz to 1000 MHz" |
| Durability | 1,000 mating cycles min. | 500 mating cycles |
| Shell to Shell Conductivity | 2.5 mV drop max | 2.5 mV drop max |
| Contacts | Per AS39029 | Per AS39029 |

| 2M804 MATERIALS AND FINISHES | |
|-----------------------------------|-----------------------------------|
| Shells | Aluminum Alloy or Stainless Steel |
| Contacts | Copper Alloy, gold plated |
| Insulators | Polyphenylene Sulfide (PPS) |
| Contact Retention | Beryllium Copper Alloy |
| Grommet, Interfacial Seal, O-Ring | Fluorosilicone Rubber |
| Canted Coil Spring | Stainless Steel, Gold plated |



2M804 Push-Pull Crimp Receptacles

Ordering Guide for 2M804-001, 002, 003, 004



| 1. SERIES | 2. SHELL STYLE | 3. SERVICE CLASS | 4. SHELL SIZE-INSERT ARRANGEMENT | 5. CONTACTS | 6. KEYING | 7. SUFFIX |
|-----------|----------------|------------------|----------------------------------|-------------|-----------|-----------|
| 2M804-00X | -06 | ZNU | 6-7 | P | A | |

2M804

| 1. SERIES | | 2. SHELL STYLE RECEPTACLE | | 3. SERVICE CLASS | | | | | |
|------------|-------------------------------|---|-------------------------------|-----------------------------------|----------|-----------------|---------------------------|---------------------|--|
| Type | Part # | Description | Part # | Description | Material | Part # | Description | RoHS | |
| CRIMP | PLUGS | | PLUGS | | ALUMINUM | C | Anodized (Non-conductive) | | |
| | 2M804-001 | Plug with Integral Backshell | -06 | Plug | | M | Electroless Nickel | | |
| | 2M804-002 | Plug with Accessory Threads | | | | NF | Olive Drab Cadmium | | |
| | RECEPTACLE | | RECEPTACLE | | | MT | Durmalon (Ni PTFE) | | |
| | 2M804-003 | Receptacle with Banding Platform | -00 | Jam Nut* for Front Panel | | ZN | Olive Drab Zinc Nickel | | |
| | 2M804-004 | Receptacle with Accessory Threads | -01 | In-Line | | | | | |
| PCB/SOLDER | PCB/SOLDER RECEPTACLES | | PCB/SOLDER RECEPTACLES | | | ZNU | Black Zinc Nickel | | |
| | 2M804-005 | Receptacle w/ Epoxy Potting | -00 | Jam Nut* for Front Panel Mounting | | BEN | Black Electroless Nickel | | |
| | 2M804-020 | Receptacle for Open Face Immersion | -07 | Jam Nut* Rear Panel Mounting | | STAINLESS STEEL | Z1 | Passivated | |
| | 2M804-025 | Receptacle with Standoff Flange for Mechanical PCB Strain Relief | PCB/SOLDER PLUGS | | | | ZL | Electrolytic Nickel | |
| | 2M804-009 | Plugs with Solder Cup or PCB termination with Standard Epoxy Potting | -00 | Jam Nut for Front Panel mounting | | | | | |
| | 2M804-021 | Plugs with Solder Cup or PCB Termination with Special Sealing for Open Face (unmated) Water Immersion Requirements. 100% Leak Tested. To maintain a helium leak rate of 1x10 ⁻⁴ cc/sec. pressure differential from -65°C to 175°C. | -07 | Jam Nut for Rear Panel Mounting | | | | | |
| | | | -02 | Flange Mount, Rear Panel | | | | | |
| | | | | | | | | | |

*add "-501" as a suffix to the Jam Nut Part number to include a Hex Nut instead of a Spanner Nut.

4. SHELL SIZE-INSERT ARRANGEMENT
See Table on pages 7-20

| 5. CONTACTS | | |
|-------------------|----------|----------------------|
| Style | Part # | Description |
| CRIMP | P | Pin |
| | S | Socket |
| | A | Pin-Less Contacts |
| | B | Socket-Less Contacts |
| PCB/SOLDER | | |
| PCB/SOLDER | P | Pin-PCB |
| | S | Socket-PCB |
| | E | Pin-Solder Cup |
| | F | Socket-Solder Cup |

| 6. KEYING* | | |
|------------|------|------|
| Part # | A° | B° |
| A | 150° | 210° |
| B | 75° | 210° |
| C | 95° | 230° |
| D | 140° | 275° |

*For single master key omit (leave blank)

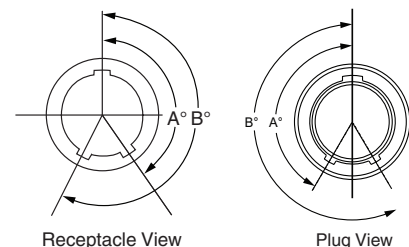

For additional assistance building a part number and for 3D models, please visit www.amphenol-aerospace.com to access our 2M configurator.

D

2M804 Push-Pull Quick-Disconnect Connector Weights



| SERIES 2M804 WEIGHTS IN GRAMS | | | | |
|-------------------------------|------|--------------------|-------------|--------------------|
| Insert Arrg. | Plug | Jam Nut Receptacle | | In-Line Receptacle |
| | | Rear Mount | Front Mount | |
| 5-3P | 2.2 | 8.0 | 9.7 | 4.0 |
| 5-3S | 2.4 | 8.3 | 9.8 | 4.1 |
| 6-1P | 3.1 | 7.2 | 11.8 | 5.2 |
| 6-1S | 3.4 | 7.5 | 12.1 | 5.5 |
| 6-4P | 2.8 | 8.8 | 11.4 | 4.8 |
| 6-4S | 3.0 | 9.0 | 11.6 | 5.1 |
| 6-7P | 3.0 | 9.1 | 11.7 | 5.3 |
| 6-7S | 3.2 | 9.5 | 12.0 | 5.5 |
| 7-1P | 3.7 | 11.1 | 16.4 | 10.1 |
| 7-1S | 4.3 | 11.7 | 16.9 | 10.7 |
| 7-10P | 3.7 | 10.9 | 16.2 | 10.0 |
| 7-10S | 4.2 | 11.3 | 16.5 | 10.3 |
| 8-2P | 5.0 | 10.9 | 13.5 | 8.0 |
| 8-2S | 5.7 | 5.7 | 11.7 | 9.0 |
| 8-13P | 4.3 | 10.6 | 12.4 | 7.4 |
| 8-13S | 4.8 | 11.0 | 13.0 | 8.1 |
| 8-200P | 5.3 | 11.2 | 13.9 | 8.4 |
| 8-200S | 6.1 | 12.0 | 14.6 | 9.1 |
| 9-4P | 5.7 | 15.2 | 21.1 | 11.0 |
| 9-4S | 6.7 | 16.2 | 22.1 | 12.0 |
| 9-19P | 4.6 | 14.1 | 20.0 | 9.9 |
| 9-19S | 4.8 | 14.9 | 21.1 | 9.8 |
| 9-200P | 5.2 | 14.6 | 20.6 | 10.5 |
| 9-200S | 6.3 | 15.7 | 21.7 | 11.6 |
| 9-201P | 5.8 | 15.3 | 21.2 | 11.1 |
| 9-201S | 6.9 | 16.4 | 22.3 | 12.2 |
| 10-5P | 7.3 | 15.5 | 23.3 | 11.9 |
| 10-5S | 8.7 | 16.9 | 24.8 | 13.3 |
| 10-26P | 5.4 | 13.6 | 20.5 | 10.1 |
| 10-26S | 6.2 | 13.9 | 21.1 | 10.5 |
| 10-200P | 6.2 | 14.4 | 22.2 | 10.8 |
| 10-200S | 7.6 | 15.8 | 23.7 | 12.2 |
| 10-201P | 6.3 | 14.5 | 22.3 | 10.9 |
| 10-201S | 7.7 | 16.0 | 23.8 | 12.3 |
| 10-202P | 6.3 | 14.5 | 22.3 | 10.9 |
| 10-202S | 7.8 | 16.1 | 23.9 | 12.4 |
| 12-2P | 10.7 | 21.5 | 26.1 | 20.8 |
| 12-2S | 12.3 | 23.1 | 27.7 | 22.4 |
| 12-3P | 11.7 | 22.4 | 27.1 | 21.8 |
| 12-3S | 13.4 | 24.2 | 28.8 | 23.4 |
| 12-7P | 11.9 | 22.7 | 27.3 | 22.0 |

| SERIES 2M804 WEIGHTS IN GRAMS | | | | |
|-------------------------------|------|--------------------|-------------|--------------------|
| Insert Arrg. | Plug | Jam Nut Receptacle | | In-Line Receptacle |
| | | Rear Mount | Front Mount | |
| 12-7S | 14.5 | 25.3 | 29.9 | 24.6 |
| 12-37P | 10.1 | 21.5 | 25.5 | 22.4 |
| 12-37S | 11.8 | 23.1 | 27.2 | 22.1 |
| 12-200P | 10.3 | 21.1 | 25.7 | 20.5 |
| 12-200S | 12.5 | 23.3 | 27.9 | 22.7 |
| 12-201P | 10.7 | 21.5 | 26.1 | 22.8 |
| 12-201S | 13.0 | 23.8 | 28.4 | 23.1 |
| 14-5P | 15.4 | 28.3 | 33.6 | 26.3 |
| 14-5S | 18.4 | 31.2 | 36.5 | 29.3 |
| 14-12P | 16.2 | 29.0 | 34.3 | 27.1 |
| 14-12S | 19.8 | 32.7 | 38.0 | 30.7 |
| 14-55P | 12.8 | 25.6 | 30.9 | 23.7 |
| 14-55S | 15.6 | 28.3 | 33.8 | 26.5 |

| SERIES 2M804 UNMATE FORCE | | |
|---------------------------|---------------|---------|
| Layout | Average Force | |
| | Pounds | Newtons |
| 5-3 | 10.6 | 47.1 |
| 6-4 | 10.8 | 48.0 |
| 6-7 | 11.4 | 50.7 |
| 7-10 | 12.0 | 53.4 |
| 8-13 | 12.6 | 56.0 |
| 9-19 | 13.8 | 61.4 |
| 10-26 | 15.2 | 67.6 |
| 12-37 | 17.4 | 77.4 |
| 14-55 | 21.0 | 93.4 |

Note: Contact Amphenol if modified force values are needed.

2M804

D

2M804 Push-Pull Plug Connector

2M804-001-06 and 2M804-002-06

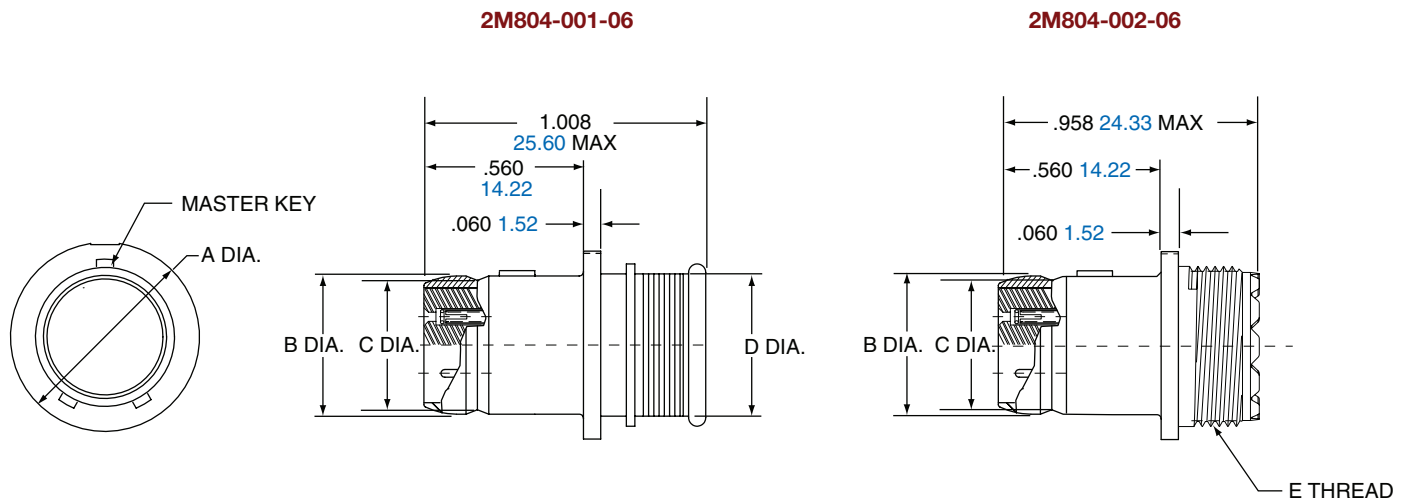

| Shell Size | A Dia. | | B Dia. | | C Dia. | | D Dia. | | E Thread UNEF-2A |
|------------|--------|-------|--------|-------|--------|-------|--------|-------|------------------|
| | in. | mm | in. | mm. | in. | mm | in. | mm. | |
| 5 | .418 | 10.62 | .245 | 6.22 | .218 | 5.54 | .248 | 6.30 | .2500-32 |
| 6 | .488 | 12.40 | .310 | 7.87 | .275 | 6.99 | .293 | 7.44 | .3125-32 |
| 7 | .561 | 14.25 | .378 | 9.60 | .350 | 8.89 | .388 | 9.86 | .4375-28 |
| 8 | .603 | 15.32 | .426 | 10.82 | .395 | 10.03 | .448 | 11.38 | .5000-28 |
| 9 | .663 | 16.84 | .482 | 12.24 | .450 | 11.43 | .503 | 12.78 | .5625-24 |
| 10 | .743 | 18.87 | .555 | 14.10 | .525 | 13.34 | .563 | 14.30 | .6250-24 |
| 12 | .851 | 21.62 | .672 | 17.07 | .642 | 16.31 | .653 | 16.59 | .6875-24 |
| 14 | .978 | 24.84 | .795 | 20.19 | .761 | 19.33 | .803 | 20.40 | .9375-20 |
| 15 | 1.038 | 26.37 | .863 | 21.92 | .837 | 21.26 | .853 | 21.67 | .9375-20 |

2M804

2M804 Push-Pull Jam Nut Rear Panel

2M804-003-07 and 2M804-004-07



2M804-004-07

2M804-003-07

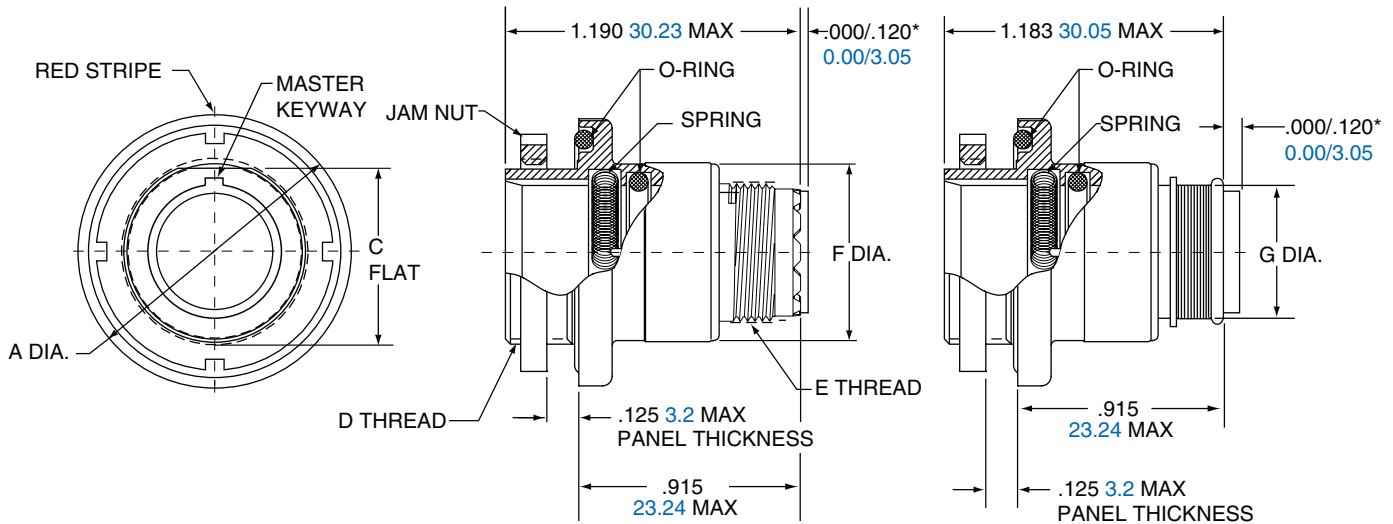

*Grommet protrudes for power/combo arrangements

| Shell Size | A Dia. | | C Flat | | D Thread UN-2A | E Thread UNEF-2A | F Dia. | | G Dia. | |
|------------|--------|-------|--------|-------|-------------------|---------------------|--------|-------|--------|-------|
| | in. | mm | in. | mm | | | in. | mm. | in. | mm. |
| 5 | .773 | 19.63 | .414 | 10.52 | .4375-32 | .2500-32 | .448 | 11.38 | .248 | 6.30 |
| 6 | .833 | 21.16 | .468 | 11.89 | .5000-32 | .3125-32 | .513 | 13.03 | .293 | 7.44 |
| 7 | .903 | 22.94 | .593 | 15.06 | .6250-28 | .4375-28 | .573 | 14.55 | .388 | 9.86 |
| 8 | .958 | 24.33 | .593 | 15.06 | .6250-28 | .5000-28 | .596 | 15.14 | .448 | 11.38 |
| 9 | .998 | 25.35 | .653 | 16.59 | .6875-28 | .5625-24 | .691 | 17.55 | .503 | 12.78 |
| 10 | 1.083 | 27.51 | .721 | 18.31 | .7500-28 | .6250-24 | .728 | 18.49 | .563 | 14.30 |
| 12 | 1.183 | 30.05 | .843 | 21.41 | .8750-28 | .6875-24 | .883 | 22.43 | .653 | 16.59 |
| 14 | 1.323 | 33.60 | .968 | 24.59 | 1.0000-28 | .9375-20 | 1.003 | 25.48 | .803 | 20.40 |
| 15 | 1.373 | 34.87 | 1.036 | 26.31 | 1.0625-20 | .9375-20 | 1.063 | 27.00 | .853 | 21.67 |

JAM NUT PANEL CUTOUT

| Shell Size | A Flat | | B Dia. | |
|------------|--------------|---------------|--------------|---------------|
| | in. ±.002 | mm. ± 0.05 | in. ±.005 | mm. ± 0.13 |
| 5 | .423 | 10.74 | .448 | 11.38 |
| 6 | .475 | 12.07 | .510 | 12.95 |
| 7 | .602 | 15.29 | .635 | 16.13 |
| 8 | .602 | 15.29 | .635 | 16.13 |
| 9 | .663 | 16.84 | .698 | 17.73 |
| 10 | .729 | 18.82 | .760 | 19.30 |
| 12 | .851 | 21.62 | .885 | 22.48 |
| 14 | .976 | 24.79 | 1.010 | 25.65 |
| 15 | 1.043 | 26.49 | 1.073 | 27.25 |

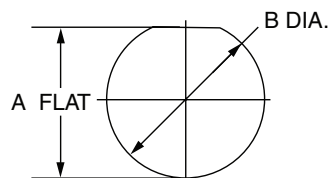

2M804 Push-Pull Jam Nut Front Panel Recept.

2M804-003-00 and 2M804-004-00

2M804-004-00

2M804-003-00

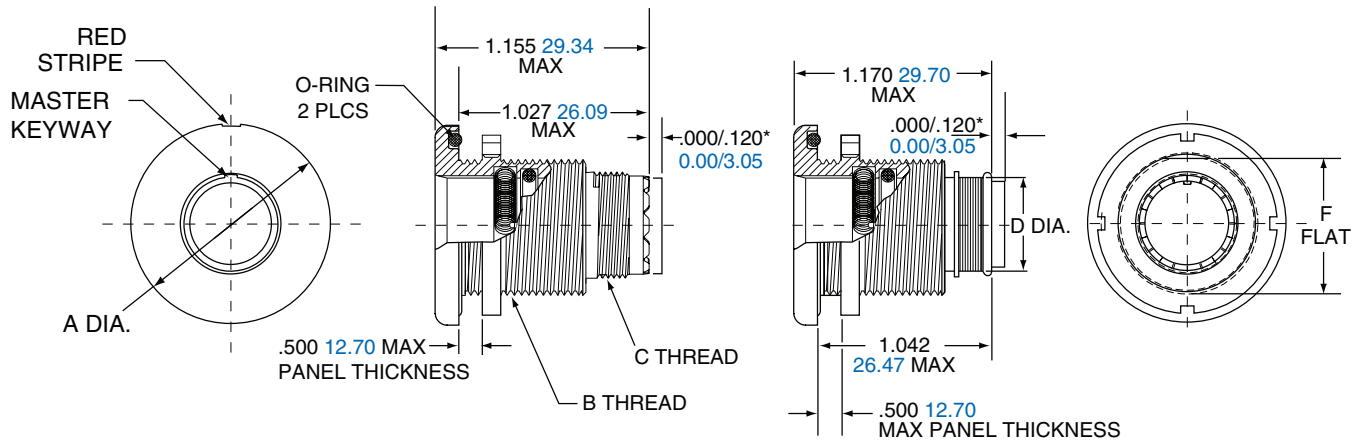

*Grommet protrudes for power/combo arrangements

| Shell Size | A Dia. | | B Thread UN-2A | C Thread UNEF-2A | D Dia. | | F Flat. | |
|------------|--------|-------|----------------|------------------|--------|-------|---------|-------|
| | in. | mm | | | in. | mm. | in. | mm. |
| 5 | .830 | 21.08 | .5000-32 | .2500-32 | .248 | 6.30 | .470 | 11.94 |
| 6 | .884 | 22.45 | .5625-32 | .3125-32 | .293 | 7.44 | .529 | 13.44 |
| 7 | .994 | 25.25 | .6875-28 | .4375-28 | .388 | 9.86 | .663 | 16.84 |
| 8 | .994 | 25.25 | .6875-28 | .5000-28 | .448 | 11.38 | .663 | 16.84 |
| 9 | 1.073 | 27.25 | .7500-28 | .5625-24 | .503 | 12.78 | .719 | 18.26 |
| 10 | 1.138 | 28.91 | .8125-28 | .6250-24 | .563 | 14.30 | .778 | 19.76 |
| 12 | 1.338 | 33.96 | 1.0000-28 | .6875-24 | .653 | 16.59 | .969 | 24.61 |
| 14 | 1.388 | 35.26 | 1.0625-20 | .9375-20 | .803 | 20.40 | 1.019 | 25.88 |
| 15 | 1.453 | 36.91 | 1.1250-28 | .9375-20 | .853 | 21.67 | 1.113 | 28.27 |

PANEL CUTOUT

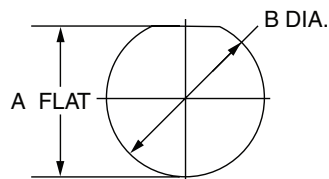

| Shell Size | A Flat | | B Dia. | |
|------------|--------------|---------------|--------------|---------------|
| | in. ±.002 | mm. ± 0.05 | in. ±.005 | mm. ± 0.13 |
| 5 | .477 | 12.12 | .510 | 12.95 |
| 6 | .537 | 13.64 | .573 | 14.55 |
| 7 | .670 | 17.02 | .698 | 17.73 |
| 8 | .670 | 17.02 | .698 | 17.73 |
| 9 | .727 | 18.47 | .760 | 19.30 |
| 10 | .787 | 20.19 | .823 | 20.90 |
| 12 | .977 | 24.82 | 1.010 | 25.65 |
| 14 | 1.027 | 26.09 | 1.073 | 27.25 |
| 15 | 1.121 | 28.47 | 1.135 | 28.83 |

2M804 Push-Pull In-Line Receptacle

2M804-003-01 and 2M804-004-01



2M804-004-01

2M804-003-01

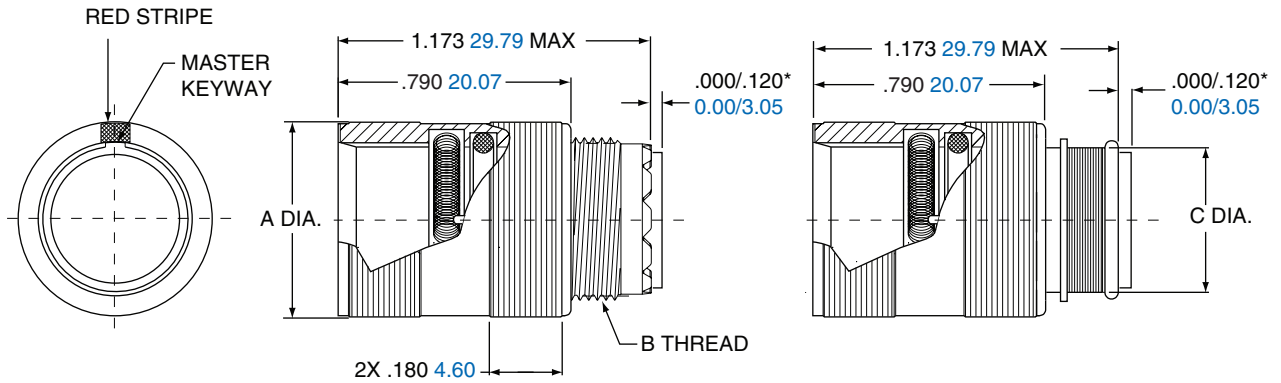

*Grommet protrudes for power/combo arrangements

| Shell Size | A Dia. | | B Thread UNEF-2A | C Dia. | |
|------------|--------|-------|---------------------|--------|-------|
| | in. | mm | | in. | mm. |
| 5 | .453 | 11.51 | .2500-32 | .248 | 6.30 |
| 6 | .523 | 13.28 | .3125-32 | .293 | 7.44 |
| 7 | .583 | 14.81 | .4375-28 | .388 | 9.86 |
| 8 | .606 | 15.39 | .5000-28 | .448 | 11.38 |
| 9 | .698 | 17.73 | .5625-24 | .503 | 12.78 |
| 10 | .738 | 18.75 | .6250-24 | .563 | 14.30 |
| 12 | .883 | 22.43 | .6875-24 | .653 | 16.59 |
| 14 | 1.013 | 25.73 | .9375-20 | .803 | 20.40 |
| 15 | 1.061 | 26.95 | .9375-20 | .853 | 21.67 |

2M804

D

2M804 PCB/ Solder Rear Panel Jam Nut Recpt. 2M804-005-07 and 2M804-020-07

2M804-005-07
2M804-020-07

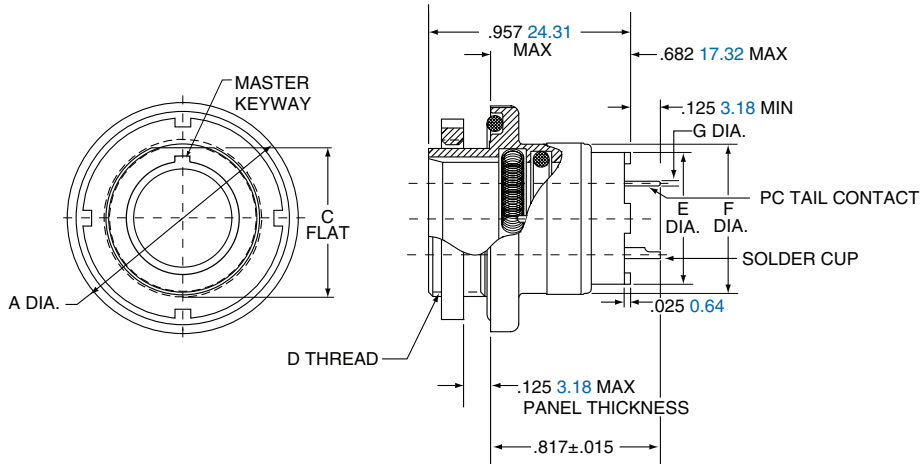

| Shell Size | A Dia. | | C Flat | | D Thread UN-2A | E Dia. | | F Dia. | | G PC Tail Dia. |
|------------|--------|-------|--------|-------|----------------|--------|-------|--------|-------|------------------------------------|
| | in. | mm. | in. | mm. | | in. | mm. | in. | mm. | |
| 5 | .773 | 19.63 | .414 | 10.52 | .4375-32 | .274 | 6.96 | .448 | 11.38 | #23 .018/.022 0.46/0.56 |
| 6 | .833 | 21.16 | .468 | 11.89 | .5000-32 | .329 | 8.36 | .513 | 13.03 | |
| 7 | .903 | 22.94 | .593 | 15.06 | .6250-28 | .431 | 10.95 | .573 | 14.55 | #20/20HD .025/.027 0.64/0.69 |
| 8 | .958 | 24.33 | .593 | 15.06 | .6250-28 | .493 | 12.52 | .596 | 15.14 | |
| 9 | .998 | 25.35 | .653 | 16.59 | .6875-28 | .551 | 14.00 | .691 | 17.55 | #16 .060/.064 1.52/1.63 |
| 10 | 1.083 | 27.51 | .721 | 18.31 | .7500-28 | .619 | 15.72 | .728 | 18.49 | |
| 12 | 1.183 | 30.05 | .843 | 21.41 | .8750-28 | .703 | 17.86 | .883 | 22.43 | #12 .092/.096 2.34/2.44 |
| 14 | 1.323 | 33.60 | .968 | 24.59 | 1.0000-28 | .863 | 21.92 | 1.003 | 25.48 | |
| 15 | 1.373 | 34.87 | 1.036 | 26.31 | 1.0625-20 | .913 | 23.19 | 1.063 | 27.00 | |

JAM NUT PANEL CUTOUT

| Shell Size | A Flat | | B Dia. | |
|------------|--------------|---------------|--------------|---------------|
| | in. ±.002 | mm. ± 0.05 | in. ±.005 | mm. ± 0.13 |
| 5 | .423 | 10.74 | .448 | 11.38 |
| 6 | .475 | 12.07 | .510 | 12.95 |
| 7 | .602 | 15.29 | .635 | 16.13 |
| 8 | .602 | 15.29 | .635 | 16.13 |
| 9 | .663 | 16.84 | .698 | 17.73 |
| 10 | .729 | 18.82 | .760 | 19.30 |
| 12 | .851 | 21.62 | .885 | 22.48 |
| 14 | .976 | 24.79 | 1.010 | 25.65 |
| 15 | 1.043 | 26.49 | 1.073 | 27.25 |

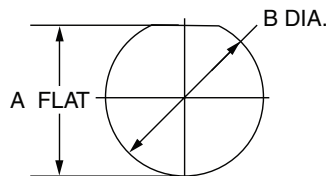

2M804 PCB/ Solder Cup Jam Nut Front Panel

2M804-005-00 and 2M804-020-00



2M804

D

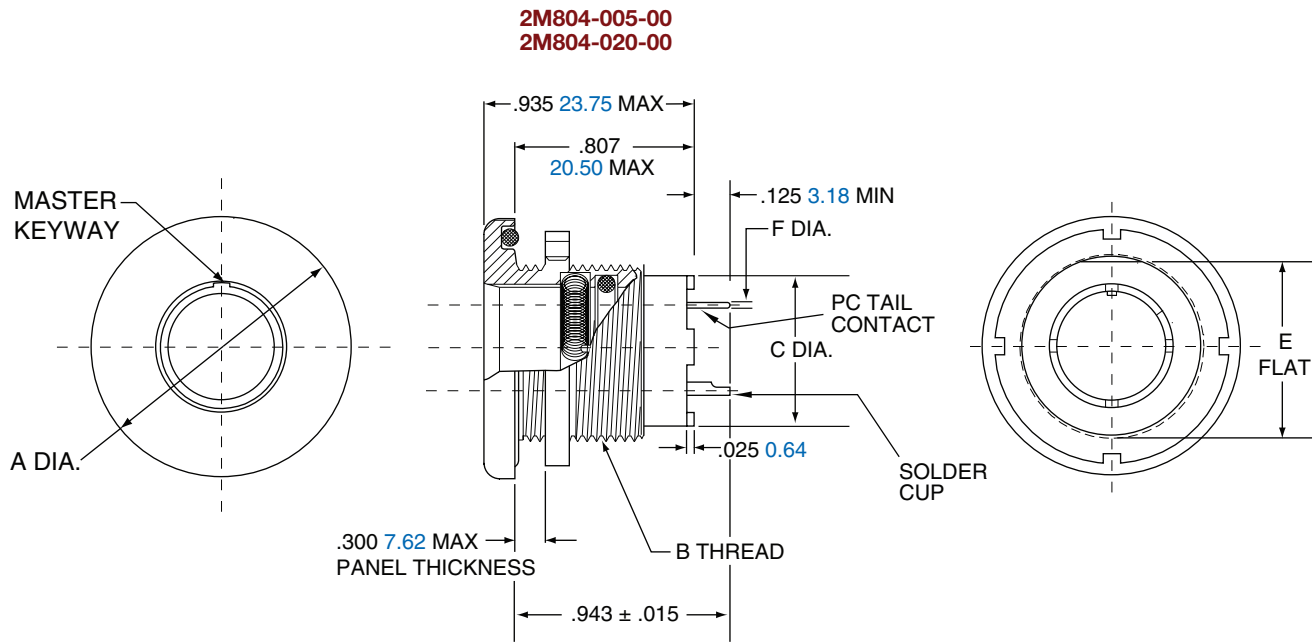

| Shell Size | A Dia. | | B Thread UN-2A | C Dia. | | E Flat. | | F Dia. Tail Dia. |
|------------|--------|-------|----------------|--------|-------|---------|-------|------------------------------------|
| | in. | mm. | | in. | mm. | in. | mm. | |
| 5 | .830 | 21.08 | .5000-32 | .274 | 6.96 | .470 | 11.94 | #23 .018/.022 0.46/0.56 |
| 6 | .884 | 22.45 | .5625-28 | .329 | 8.36 | .529 | 13.44 | #20/20HD .025/.027 0.64/0.69 |
| 7 | .994 | 25.25 | .6875-28 | .431 | 10.95 | .663 | 16.84 | #16 .060/.064 1.52/1.63 |
| 8 | .994 | 25.25 | .6875-28 | .493 | 12.52 | .663 | 16.84 | #12 .092/.096 2.34/2.44 |
| 9 | 1.073 | 27.25 | .7500-28 | .551 | 14.00 | .719 | 18.26 | |
| 10 | 1.138 | 28.91 | .8125-28 | .619 | 15.72 | .778 | 19.76 | |
| 12 | 1.338 | 33.99 | 1.0000-28 | .703 | 17.86 | .969 | 24.61 | |
| 14 | 1.388 | 35.26 | 1.0625-20 | .863 | 21.92 | 1.019 | 25.88 | |
| 15 | 1.453 | 36.91 | 1.1250-28 | .913 | 23.19 | 1.113 | 28.27 | |

JAM NUT PANEL CUTOUT

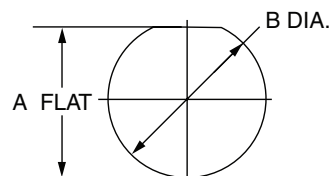

| Shell Size | A Flat | | B Dia. | |
|------------|--------------|---------------|--------------|---------------|
| | in. ±.002 | mm. ± 0.05 | in. ±.005 | mm. ± 0.13 |
| 5 | .477 | 12.12 | .510 | 12.95 |
| 6 | .537 | 13.64 | .573 | 14.55 |
| 7 | .670 | 17.02 | .698 | 17.73 |
| 8 | .670 | 17.02 | .698 | 17.73 |
| 9 | .727 | 18.47 | .760 | 19.30 |
| 10 | .787 | 20.00 | .823 | 20.90 |
| 12 | .977 | 24.82 | 1.010 | 25.65 |
| 14 | 1.027 | 26.10 | 1.073 | 27.75 |
| 15 | 1.121 | 28.47 | 1.135 | 28.83 |

2M804 Push-Pull Jam Nut Panel Mount Plug

2M804-009-07 and 2M804-021-07

2M804

2M804-009-07
2M804-021-07

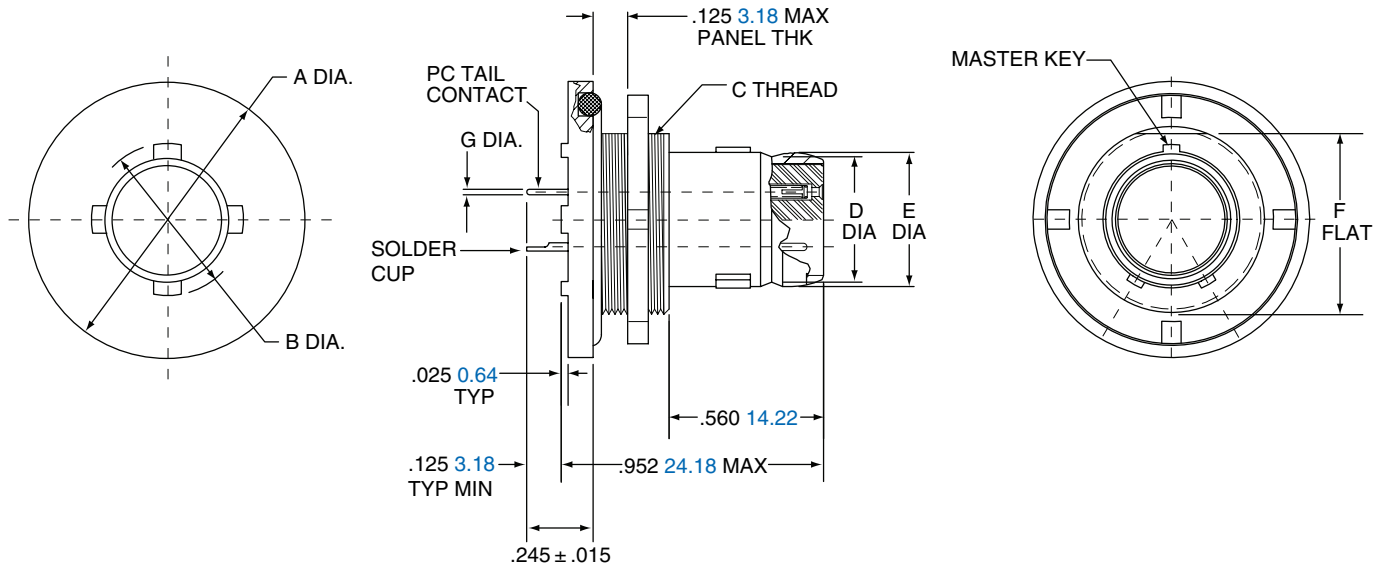

| Shell Size | A Dia. | | B Dia. | | C Thread UN-2A | D Dia. | | E Dia. | | F Flat. | | G PC Tail Dia. |
|------------|--------|-------|--------|-------|----------------|--------|-------|--------|-------|---------|-------|------------------------------------|
| | in. | mm. | in. | mm. | | in. | mm. | in. | mm. | in. | mm. | |
| 5 | .773 | 19.63 | .244 | 6.20 | .4375-32 | .218 | 5.54 | .245 | 6.22 | .414 | 10.52 | #23 .018/.022 0.46/0.56 |
| 6 | .833 | 21.16 | .330 | 8.38 | .5000-32 | .275 | 6.99 | .310 | 7.87 | .468 | 11.89 | #20/20HD .025/.027 0.64/0.69 |
| 7 | .903 | 22.94 | .432 | 10.97 | .6250-28 | .350 | 8.89 | .378 | 9.60 | .593 | 15.06 | #16 .060/.064 1.52/1.63 |
| 8 | .958 | 24.33 | .493 | 12.52 | .6250-28 | .395 | 10.03 | .426 | 10.82 | .593 | 15.06 | #12 .092/.096 2.34/2.44 |
| 9 | .998 | 25.35 | .551 | 14.00 | .6875-28 | .450 | 11.43 | .482 | 12.24 | .653 | 16.59 | |
| 10 | 1.083 | 27.51 | .620 | 15.75 | .7500-28 | .525 | 13.34 | .555 | 14.10 | .721 | 18.31 | |
| 12 | 1.183 | 30.05 | .703 | 17.86 | .8750-28 | .642 | 16.31 | .672 | 17.07 | .843 | 21.41 | |
| 14 | 1.323 | 33.60 | .863 | 21.92 | 1.0000-28 | .761 | 19.33 | .795 | 20.19 | .968 | 24.59 | |

JAM NUT PANEL CUTOUT

| Shell Size | A Flat | | B Dia. | |
|------------|-----------|------------|-----------|------------|
| | in. ±.002 | mm. ± 0.05 | in. ±.005 | mm. ± 0.13 |
| 5 | .423 | 10.74 | .448 | 11.38 |
| 6 | .475 | 12.07 | .510 | 12.95 |
| 7 | .602 | 15.29 | .635 | 16.13 |
| 8 | .602 | 15.29 | .635 | 16.13 |
| 9 | .663 | 16.84 | .698 | 17.73 |
| 10 | .729 | 18.82 | .760 | 19.30 |
| 12 | .851 | 21.62 | .885 | 22.48 |
| 14 | .976 | 24.79 | 1.010 | 25.65 |

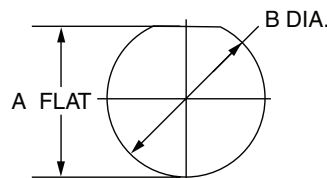

D

2M804 Push-Pull Jam Nut Front Panel Mount Plug

2M804-009-00 and 2M804-021-00



2M804-009-00
2M804-021-00

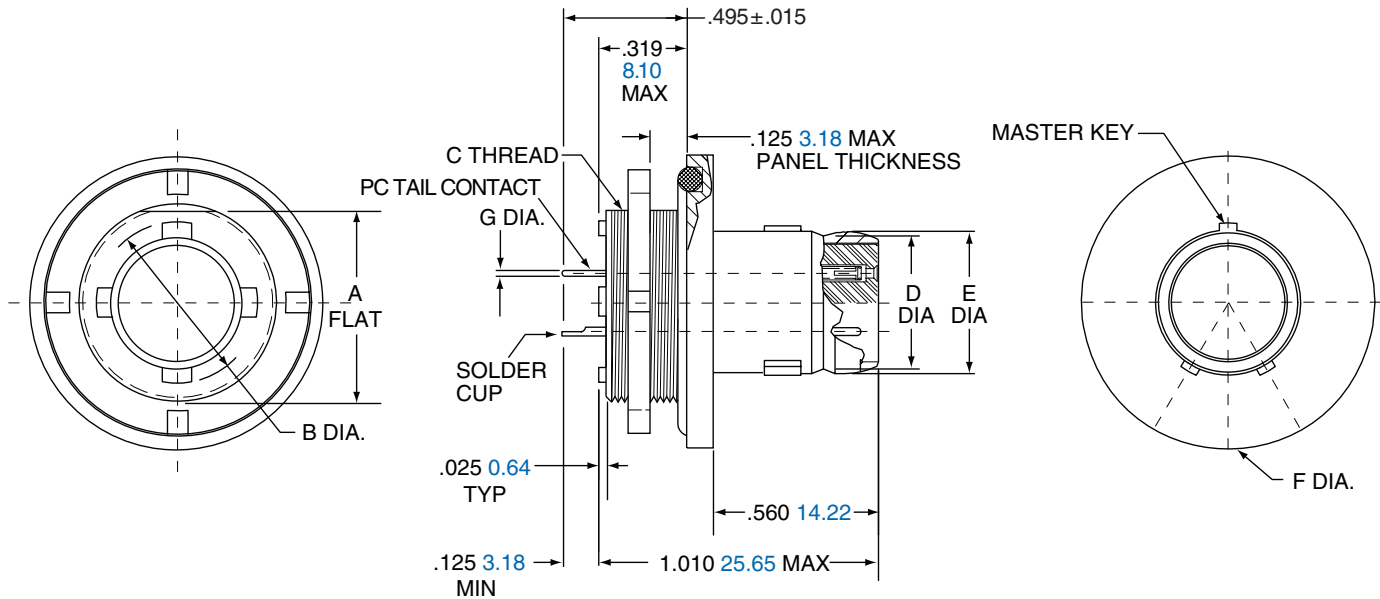

| Shell Size | A Flat. | | B Dia. | | C Thread UN-2A | D Dia. | | E Dia. | | F Dia. | | G PC Tail Dia. |
|------------|---------|-------|--------|-------|-------------------|--------|-------|--------|-------|--------|-------|------------------------------------|
| | in. | mm. | in. | mm. | | in. | mm. | in. | mm. | in. | mm. | |
| 5 | .414 | 10.52 | .244 | 6.20 | .4375-32 | .218 | 5.54 | .245 | 6.22 | .773 | 19.63 | #23 .018/.022 0.46/0.56 |
| 6 | .468 | 11.89 | .330 | 8.38 | .5000-32 | .275 | 6.99 | .310 | 7.87 | .833 | 21.16 | #20/20HD .025/.027 0.64/0.69 |
| 7 | .593 | 15.06 | .432 | 10.97 | .6250-28 | .350 | 8.89 | .378 | 9.60 | .903 | 22.94 | #16 .060/.064 1.52/1.63 |
| 8 | .593 | 15.06 | .493 | 12.52 | .6250-28 | .395 | 10.03 | .426 | 10.82 | .958 | 24.33 | #12 .092/.096 2.34/2.44 |
| 9 | .653 | 16.59 | .551 | 14.00 | .6875-28 | .450 | 11.43 | .482 | 12.24 | .998 | 25.35 | |
| 10 | .721 | 18.31 | .620 | 15.75 | .7500-28 | .525 | 13.34 | .555 | 14.10 | 1.083 | 27.51 | |
| 12 | .843 | 21.41 | .703 | 17.86 | .8750-28 | .642 | 16.31 | .672 | 17.07 | 1.183 | 30.05 | |
| 14 | .968 | 24.59 | .863 | 21.92 | 1.0000-28 | .761 | 19.33 | .795 | 20.19 | 1.323 | 33.60 | |

JAM NUT PANEL CUTOUT

| Shell Size | A Flat | | B Dia. | |
|------------|--------------|---------------|--------------|---------------|
| | in. ±.002 | mm. ± 0.05 | in. ±.005 | mm. ± 0.13 |
| 5 | .423 | 10.74 | .448 | 11.38 |
| 6 | .475 | 12.07 | .510 | 12.95 |
| 7 | .602 | 15.29 | .635 | 16.13 |
| 8 | .602 | 15.29 | .635 | 16.13 |
| 9 | .663 | 16.84 | .698 | 17.73 |
| 10 | .729 | 18.82 | .760 | 19.30 |
| 12 | .851 | 21.62 | .885 | 22.48 |
| 14 | .976 | 24.79 | 1.010 | 25.65 |

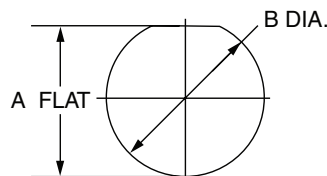

2M804 Push-Pull Flange Panel Mount Plug

2M804-009-02 and 2M804-021-02

2M804-009-02
2M804-021-02

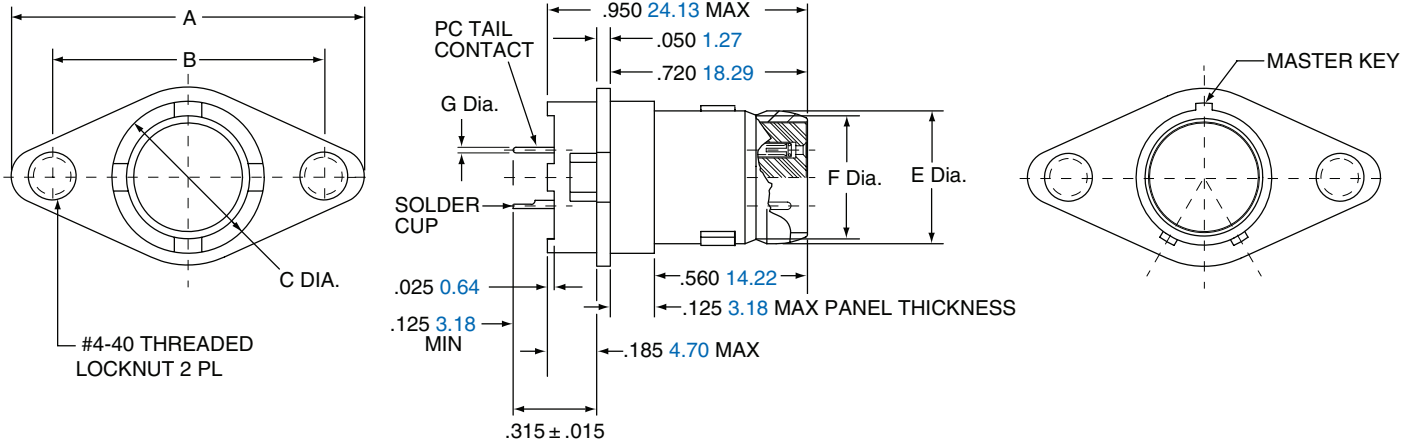

| Shell Size | A | | B | | C Dia. | | E Dia. | | F Dia. | | G PC Tail Dia. |
|------------|-------|-------|------------|------------|--------|-------|--------|-------|--------|-------|------------------------------------|
| | in. | mm. | in. ± .005 | mm. ± 0.13 | in. | mm. | in. | mm. | in. | mm. | |
| 5 | 1.055 | 26.80 | .755 | 19.18 | .323 | 8.20 | .245 | 6.22 | .218 | 5.54 | #23 .018/.022 0.46/0.56 |
| 6 | 1.120 | 28.45 | .820 | 20.83 | .388 | 9.86 | .310 | 7.87 | .275 | 6.99 | #20/20HD .025/.027 0.64/0.69 |
| 7 | 1.185 | 30.10 | .885 | 22.48 | .453 | 11.51 | .378 | 9.60 | .350 | 8.89 | #16 .060/.064 1.52/1.63 |
| 8 | 1.230 | 31.24 | .930 | 23.62 | .498 | 12.65 | .425 | 10.80 | .395 | 10.03 | #12 .092/.096 2.34/2.44 |
| 9 | 1.290 | 32.77 | .990 | 25.15 | .558 | 14.17 | .482 | 12.24 | .450 | 11.43 | |
| 10 | 1.360 | 34.54 | 1.060 | 26.92 | .628 | 15.95 | .555 | 14.10 | .525 | 13.34 | |
| 12 | 1.485 | 37.72 | 1.185 | 30.10 | .753 | 19.13 | .672 | 17.07 | .642 | 16.31 | |
| 14 | 1.600 | 40.64 | 1.300 | 33.02 | .868 | 22.05 | .795 | 20.19 | .761 | 19.33 | |

2M804

2M804 Jam Nut, Rear Panel Mount Double Flange

2M804-025-07

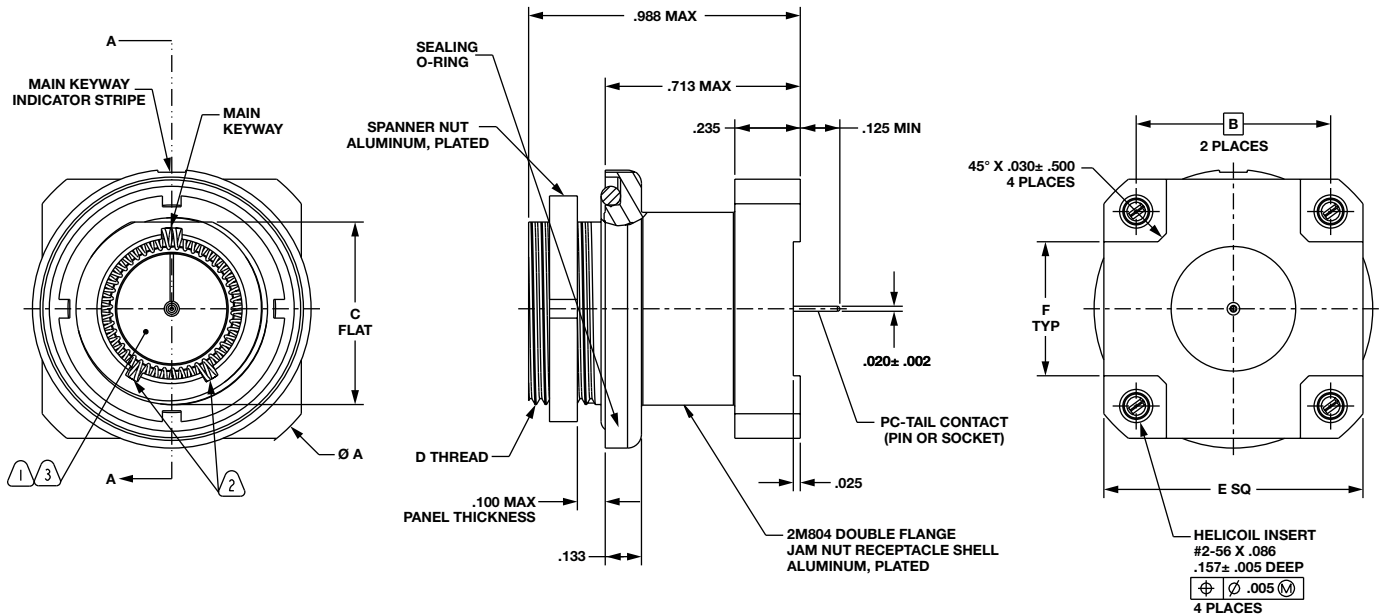

| Shell Size | A Flat. | | B | | C Flat | | D Thread UN-2A | F Type | |
|------------|---------|-------|------|-------|--------|-------|----------------|--------|-------|
| | in. | mm. | in. | mm. | in. | mm. | | in. | mm. |
| 5 | .973 | 24.71 | .496 | 12.59 | .415 | 10.54 | .4375-32 | .273 | 6.93 |
| 6 | 1.033 | 26.24 | .540 | 13.72 | .467 | 11.86 | .5000-32 | .318 | 8.07 |
| 7 | 1.110 | 28.19 | .611 | 15.52 | .594 | 15.09 | .6250-28 | .388 | 9.85 |
| 8 | 1.155 | 29.34 | .630 | 16.00 | .594 | 15.09 | .6250-28 | .408 | 10.36 |
| 9 | 1.200 | 30.48 | .698 | 17.73 | .655 | 16.63 | .6875-28 | .475 | 12.06 |
| 10 | 1.285 | 32.63 | .750 | 19.05 | .721 | 18.31 | .7500-28 | .528 | 13.41 |
| 12 | 1.390 | 35.30 | .815 | 20.70 | .843 | 21.41 | .8750-28 | .593 | 15.06 |
| 14 | 1.525 | 38.73 | .925 | 23.49 | .968 | 24.59 | 1.0000-28 | .702 | 17.83 |
| 1 | 1.573 | 39.95 | .964 | 24.48 | 1.036 | 26.31 | 1.0625-20 | .742 | 18.85 |

REAR MOUNT PANEL CUTOUT

| Shell Size | K DIA. | | J FLAT | |
|------------|-----------|------------|-----------|------------|
| | in. ±.002 | mm. ± 0.05 | in. ±.005 | mm. ± 0.13 |
| 5 | .448 | 11.37 | .425 | 10.79 |
| 6 | .510 | 12.95 | .477 | 12.11 |
| 7 | .635 | 16.13 | .604 | 15.34 |
| 8 | .635 | 16.13 | .604 | 15.34 |
| 9 | .695 | 17.65 | .665 | 16.89 |
| 10 | .760 | 19.30 | .731 | 18.56 |
| 12 | .885 | 22.48 | .853 | 21.66 |
| 14 | 1.010 | 25.65 | .978 | 24.84 |
| 15 | 1.073 | 27.25 | 1.046 | 26.56 |

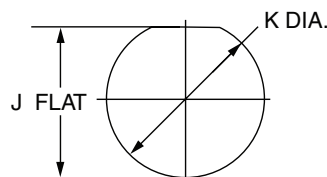

2M804 Push-Pull Receptacles Protection Caps







Ordering Guide for 2M667-202









2M804 Push-Pull Protective Caps are available in plug and receptacle versions. Protective caps keep the connector interface dry and clean while not in use. Caps come in a variety of materials, lanyard styles and lengths to accommodate specific design requirements.

| 1. SERIES | 2. SERVICE CLASS | 3. SHELL SIZE | 4. ATTACHMENT TYPE | 5. ATTACHMENT LENGTH IN INCHES | 6. ATTACHMENT CODE | 7. PULL RING OPTION |
|-----------|------------------|---------------|--------------------|--------------------------------|--------------------|---------------------|
| 2M667-202 | -M | 9 | -G | -5 | 04 | R |

| 1. SERIES | |
|-----------|-----------------------------------|
| Part # | Description |
| 2M667-202 | Protection Caps 2M804 Receptacles |

| 4. ATTACHMENT TYPE | | |
|---|--------|--|
| | Part # | Description |
|  | -G | Nylon Rope |
|  | -H | Stainless Steel Wire Rope, Teflon® Jacket |
| | -N | No Attachment |
|  | -S | Stainless Steel Sash Chain |
|  | -SK | Nylon Rope With Slip Knot |
|  | -T | Stainless Steel Wire Rope, No Jacket |
|  | -U | Stainless Steel Wire Rope, Polyurethane Jacket |

| 5. ATTACHMENT LENGTH IN INCHES | |
|--|-------------|
| -5 | Inch Length |
| Omit for attachment Type N (No Attachment) Example "-5" equals five inch length | |

| 2. SERVICE CLASS | | | |
|------------------|--------|---------------------------------|--|
| Material | Part # | Description | RoHS |
| Aluminum | -C | Black Anodized (Non-conductive) |  |
| | -M | Electroless Nickel |  |
| | -NF | Olive Drab Cadmium | |
| | -MT | Durmalon (Ni PTFE) |  |
| | -ZN | Olive Drab Zinc Nickel |  |
| | -ZNU | Black Zinc Nickel |  |
| Stainless Steel | -Z1 | Passivated |  |
| | -ZL | Electrolytic Nickel |  |

| 3. SHELL SIZE | |
|---------------|--|
| 5 | |
| 6 | |
| 7 | |
| 8 | |
| 9 | |
| 10 | |
| 12 | |
| 14 | |

| 7. PULL RING OPTION | |
|---------------------|-------------------------|
| R | Supplied with Pull Ring |
| | Omit for None |

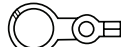
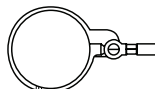
| 6. ATTACHMENT CODE | | |
|---|------------|------------------------|
| Omit for attachment Types N (No Attachment) and SK (Slip Knot) | | |
|  | Small Ring | 01 -.126 (3.20) I.D. |
| | | 02 -.145 (3.68) I.D. |
| | | 04 -.188 (4.78) I.D. |
| | | 06 -.197 (5.00) I.D. |
| | | 14 -.385 (9.78) I.D. |
| | | 15 -.445 (11.30) I.D. |
|  | Large Ring | 16 -.570 (14.48) I.D. |
| | | 17 -.635 (16.13) I.D. |
| | | 18 -.695 (17.65) I.D. |
| | | 19 -.885 (22.48) I.D. |
| | | 20 -1.070 (27.17) I.D. |
| | | 21 -1.135 (28.83) I.D. |
|  | Split Ring | 25 -1.530 (38.86) I.D. |
| | | 50 -.420 (10.67) I.D. |
| | | 52 -.480 (12.19) I.D. |
| | | 54 -.635 (16.13) I.D. |
| | | 56 -.745 (18.92) I.D. |
| | | 58 -.885 (22.48) I.D. |
| | | 60 -1.010 (25.65) I.D. |
| | | 64 -1.125 (28.58) I.D. |
| | | 68 -1.345 (34.16) I.D. |

Assembly Instructions for Protection Cap, see page 100.

2M804 Push-Pull Plug Protection Caps

Ordering Guide for 2M809-198



| 1. SERIES | 2. SERVICE CLASS | 3. SHELL SIZE | 4. ATTACHMENT TYPE | 5. ATTACHMENT LENGTH IN INCHES | 6. ATTACHMENT CODE |
|-----------|------------------|---------------|--------------------|--------------------------------|--------------------|
| 2M809-198 | -M | 9 | -G | -5 | 04 |

| 1. SERIES | | 2. SERVICE CLASS | | | 3. SHELL SIZE | | |
|-----------|-------------------------------|------------------|-----------------|------------------------------------|---------------|---|--|
| Part # | Description | Material | Part # | Description | RoHS | | |
| 2M809-198 | Protection Caps 2M804 Plug | Aluminum | -C | Black Anodized (Non-conductive) | | 5 | |
| | | | -M | Electroless Nickel | | 6 | |
| -NF | Olive Drab Cadmium | | | 7 | | | |
| -MT | Durmalon (Ni PTFE) | | | 8 | | | |
| -ZN | Olive Drab Zinc Nickel | | | 9 | | | |
| -ZNU | Black Zinc Nickel | | | 10 | | | |
| -Z1 | Passivated | | | 12 | | | |
| -ZL | Electrolytic Nickel | | | 14 | | | |
| | | | Stainless Steel | | | | |

4. ATTACHMENT TYPE

| | Part # | Description |
|--|--------|--|
| | -G | Nylon Rope |
| | -H | Stainless Steel Wire Rope, Teflon® Jacket |
| | -N | No Attachment |
| | -S | Stainless Steel Sash Chain |
| | -SK | Nylon Rope With Slip Knot |
| | -T | Stainless Steel Wire Rope, No Jacket |
| | -U | Stainless Steel Wire Rope, Polyurethane Jacket |

5. ATTACHMENT LENGTH IN INCHES

| | |
|--|-------------|
| -5 | Inch Length |
| Omit for attachment Type N (No Attachment) Example "-5" equals five inch length | |

6. ATTACHMENT CODE

| | | Omit for attachment Types N (No Attachment) and SK (SlipKnot) | For Shell Size | |
|--|------------|---|---------------------|-------|
| | Small Ring | 01 | -.126 (3.20) I.D. | |
| | | 02 | -.145 (3.68) I.D. | |
| | | 04 | -.188 (4.78) I.D. | |
| | | 06 | -.197 (5.00) I.D. | |
| | | 16 | -.570 (14.48) I.D. | 5 |
| | | 17 | -.635 (16.13) I.D. | 6 |
| | Large Ring | 18 | -.695 (17.65) I.D. | 7,8 |
| | | 19 | -.885 (22.48) I.D. | 9 |
| | | 20 | -1.070 (27.17) I.D. | 10,12 |
| | | 21 | -1.135 (28.83) I.D. | 14,15 |
| | | 50 | -.420 (10.67) I.D. | |
| | | 52 | -.480 (12.19) I.D. | |
| | Split Ring | 54 | -.635 (16.13) I.D. | |
| | | 56 | -.745 (18.92) I.D. | |
| | | 58 | -.885 (22.48) I.D. | |
| | | 60 | -1.010 (25.65) I.D. | |
| | | 64 | -1.125 (28.58) I.D. | |
| | | 68 | -1.345 (34.16) I.D. | |

6. ADDITIONAL ATTACHMENT CODE

| | | Omit for attachment Types N (No Attachment) and SK (Slip Knot) | |
|--|------------|--|---------------------|
| | Large Ring | 14 | -.385 (9.78) I.D. |
| | | 15 | -.445 (11.30) I.D. |
| | | 22 | -1.210 (11.30) I.D. |
| | | 23 | -1.275 (11.30) I.D. |
| | | 24 | -1.375 (20.8) I.D. |
| | | 25 | -1.530 (38.86) I.D. |

Assembly Instructions for Protection Cap, see page 100.

2M804

D

2M804 Push-Pull Protection Cap

Metal Protection Cap 2M809-198 and 2M667-202

2M809-198

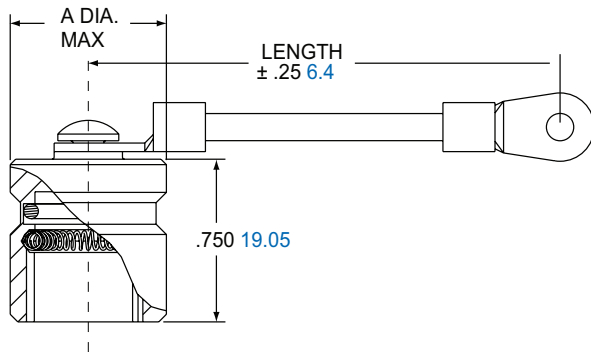

2M667-202

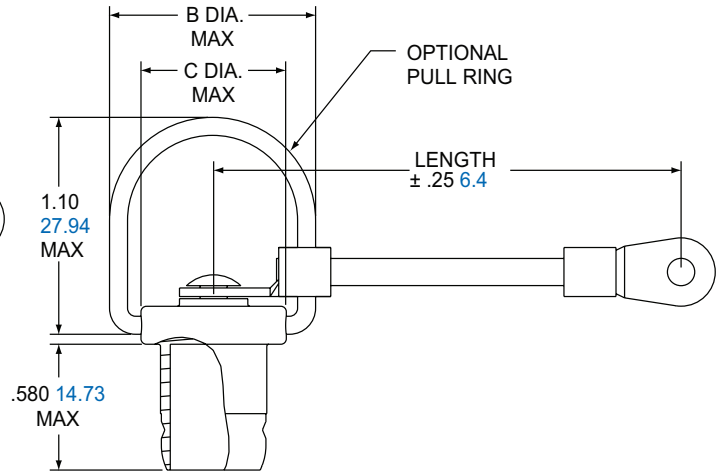

| Shell Size | A Max. | | B Max. | | C Max. | |
|------------|--------|-------|--------|-------|--------|-------|
| | in. | mm. | in. | mm. | in. | mm. |
| 5 | .483 | 12.27 | .720 | 18.29 | .498 | 12.65 |
| 6 | .533 | 13.54 | .720 | 18.29 | .503 | 12.78 |
| 7 | .633 | 16.08 | .800 | 20.32 | .578 | 14.68 |
| 8 | .658 | 16.71 | .850 | 21.59 | .627 | 15.93 |
| 9 | .708 | 17.98 | .900 | 22.86 | .678 | 17.22 |
| 10 | .783 | 19.89 | 1.010 | 25.65 | .791 | 20.09 |
| 12 | .908 | 23.06 | 1.090 | 27.69 | .868 | 22.05 |
| 14 | 1.033 | 26.24 | 1.210 | 30.73 | .988 | 25.10 |
| 15 | 1.083 | 27.51 | 1.260 | 32.00 | 1.038 | 26.37 |

MATERIALS AND FINISHES

| | |
|----------------|-----------------------------------|
| Cover | Aluminum alloy or stainless steel |
| O-Ring | Fluorosilicone rubber |
| Wire, Hardware | Stainless steel, passivated |

2M804 Push-Pull Plug Rubber Caps

Ordering Guide for 2M809-083 and 2M809-087



Push-Pull Rubber Protective Caps can be used on the 2M804 push-pull plugs and receptacles. These molded rubber covers are ideal for a protective splash-proof option.







| 1. SERIES | 2. SHELL SIZE | 3. ATTACHMENT TYPE | 4. LANYARD LENGTH | 5. ATTACHMENT CODE | 6. CONDUCTIVE RUBBER |
|-----------|---------------|--------------------|-------------------|--------------------|----------------------|
| 2M809-083 | -6 | G | 5 | -04 | C |

| 1. SERIES | |
|-----------|--------------------------------------|
| Part # | Description |
| 2M809-083 | Protection Caps 2M804 Plug |
| 2M809-087 | Protection Caps 2M804 Receptacles |

| 2. SHELL SIZE |
|---------------|
| -5 |
| -6 |
| -7 |
| -8 |
| -9 |
| -10 |
| -12 |
| -14 |

| 3. ATTACHMENT TYPE | |
|--------------------|---------------|
| G | Nylon Rope |
| N | No Attachment |

| 4. LANYARD LENGTH | |
|--------------------------------------|-------------|
| 5 | Inch length |
| Example "-5" equals five inch length | |

| 5. ATTACHMENT CODE | | | |
|---|-----|---|-------------------|
|  | -WS | Nylon Cable tie, 1.77 Inch (45mm) Maximum Wire Bundle Diameter | |
|  | -SK | Slip Knot | |
| | -00 | Lanyard with no attachment (fused End) | |
|  | -01 | -.147 (3.73) I.D. | |
| | -02 | -.147 (3.73) I.D. | |
| | -04 | -.173 (3.94) I.D. | |
| | -06 | -.197 (5.00) I.D. | |
| | | | For Shell Size |
|  | -16 | -.570 (14.48) I.D. | 5 |
| | -17 | -.635 (16.13) I.D. | 6 |
| | -18 | -.695 (17.65) I.D. | 7,8 |
| | -19 | -.885 (22.48) I.D. | 9 |
| | -20 | -1.070 (27.18) I.D. | 10,12 |
| | -21 | -1.135 (28.83) I.D. | 14,15 |

| 5. ADDITIONAL ATTACHMENT CODE | | | |
|---|------------|-----|---------------------|
| | | -07 | -.385 (9.78) I.D. |
| | | -08 | -.510 (13.11) I.D. |
| | | -09 | -.583 (14.81) I.D. |
| | | -10 | -.766 (19.4) I.D. |
|  | Large Ring | -11 | -.896 (25.76) I.D. |
| | | -12 | -1.015 (25.78) I.D. |
| | | -14 | -.385 (9.78) I.D. |
| | | -15 | -.445 (11.30) I.D. |
| | | -22 | -1.210 (11.30) I.D. |
| | | -23 | -1.275 (11.30) I.D. |
| | | -24 | -1.375 (20.8) I.D. |

| 6. CONDUCTIVE RUBBER | |
|----------------------------|-------------------|
| Omit for Standard Neoprene | |
| C | Conductive Rubber |

Assembly Instructions for Protection Cap, see page 100.

2M804 Push-Pull Plug Rubber Caps

Rubber Caps 2M809-083 and 2M809-087

2M804

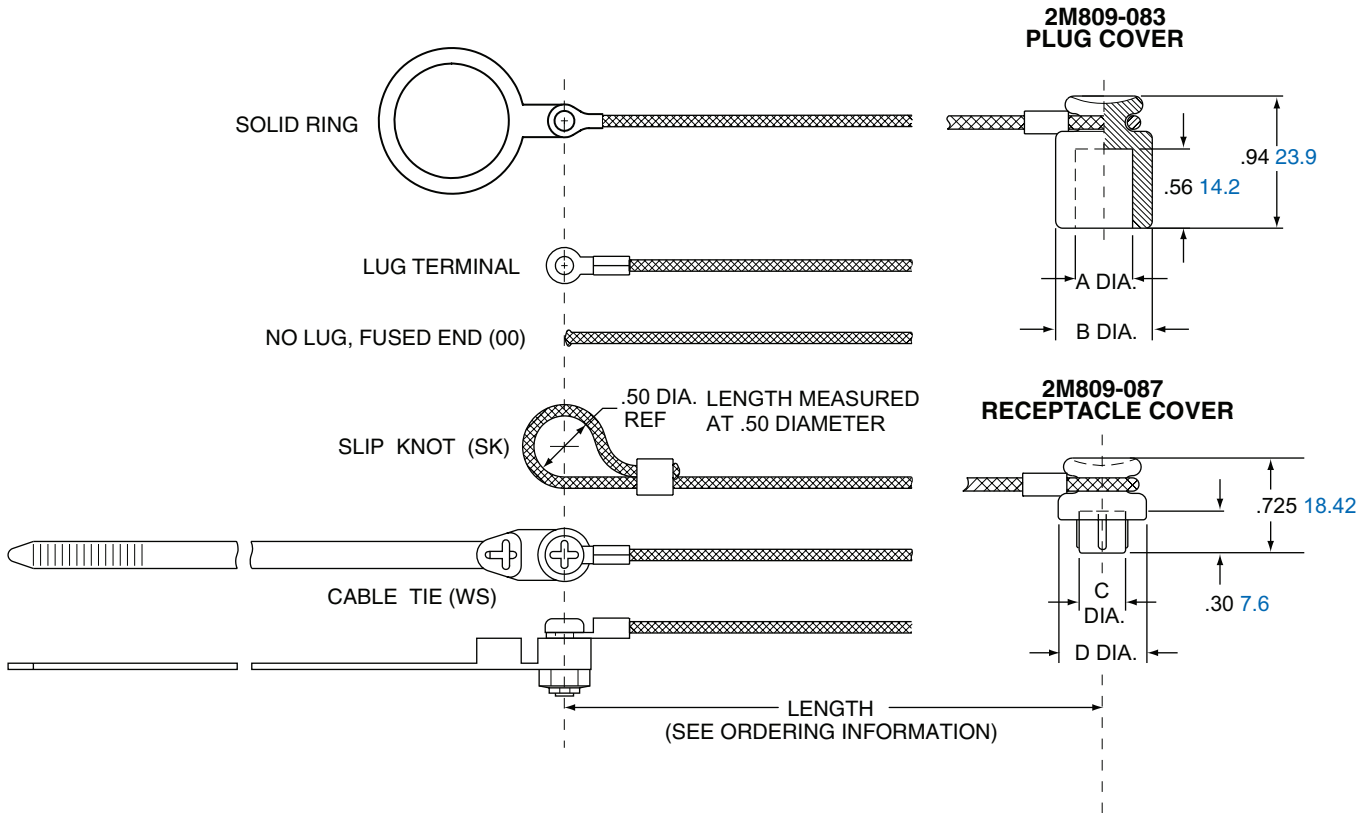

| Shell Size | A Dia. | | B Dia. | | C Dia. | | D Dia. | |
|------------|--------|-------|------------|------------|--------|-------|--------|-------|
| | in. | mm. | in. ± .005 | mm. ± 0.13 | in. | mm. | in. | mm. |
| 5 | .230 | 5.84 | .560 | 14.22 | .293 | 7.44 | .638 | 16.21 |
| 6 | .290 | 7.37 | .560 | 14.22 | .358 | 9.09 | .700 | 17.78 |
| 7 | .360 | 9.14 | .560 | 14.22 | .418 | 10.62 | .825 | 20.96 |
| 8 | .410 | 10.41 | .680 | 17.27 | .473 | 12.01 | .825 | 20.96 |
| 9 | .460 | 11.68 | .680 | 17.27 | .526 | 13.36 | .888 | 22.56 |
| 10 | .540 | 13.72 | .790 | 20.07 | .603 | 15.32 | .950 | 24.13 |
| 12 | .650 | 16.51 | .790 | 20.07 | .724 | 18.39 | 1.075 | 27.31 |
| 14 | .780 | 19.81 | 1.110 | 28.19 | .845 | 21.46 | 1.200 | 30.48 |
| 15 | .845 | 21.46 | 1.110 | 28.19 | .900 | 22.86 | 1.325 | 33.66 |

| MATERIALS | |
|-----------|---|
| Cover | Neoprene rubber blend, black |
| Lanyard | .062" (1.57) diameter nylon cord, black |
| Cable Tie | 6/6 nylon, black SST locking tab |
| Ring | Stainless steel |

2M803 1/4 Turn Bayonet Coupling

Introduction and Specifications



Page Guide

| | |
|----------------------|---------|
| Order..... | E-59 |
| Weight..... | E-60 |
| Plugs..... | E-61 |
| Jam Nut..... | E-62 |
| Flange Mount..... | E-63 |
| In-Line..... | E-64 |
| PCB/ Flange Mt. | |
| & Jam Nut..... | E-65 |
| Protection Caps..... | E-66-67 |

Amphenol's 2M Micro38999 Connector Series... The New Aerospace Standard

Averaging less than half the size and weight of their 38999 ancestors, Amphenol's 2M Micro38999 series are an easy and inexpensive way to take weight out of your system. 2M meet or exceed most environmental and performance requirements listed in MIL-DTL-38999, so modernizing your equipment doesn't mean sacrificing ruggedness. With almost 2,000,000 configurations in every termination style and a full complement of accessories available right out of the catalog, customization has never been easier. Smarter, faster and smaller: Amphenol's 2M... the only connector you'll ever need.

2M803 Features

- Bayonet Coupling
- Quickest turn-mating of the 2M series
- 1,000 mating cycles
- Lightest of the 2M series



Why 2M803?

2M803 connectors are very light; and their fast, sure-mate bayonet coupling make them the perfect choice for light duty applications that require frequent disconnect. Their small size and easy decoupling also make them the connector of choice for customers who have hard-to-reach panels. Unlike their other 2M counterparts, 2M803 connectors are not rated for immersion, and are recommended for general purpose connections that will not be exposed to the elements for very long.

2M803

2M803 VS 38999

| SPECIFICATION | 2M803 | MIL-DTL-38999 SERIES II |
|-----------------------------|--|--|
| Signal Count | 1 to 55 | 1 to 187 |
| Insulation Resistance | 5,000 megaohms min | 5,000 megaohms min |
| Operating Temperature | -65°C to +175°C | -65°C to +175°C |
| Shock | 300 G ± 15 | 300 G ± 15 |
| Vibration | "37.0 G Random 30.0 G Sine" | N/A |
| Shielding Effectiveness | "40 dB min. from 100 MHz to 1000 MHz" | "45 dB min. from 100 MHz to 1000 MHz" |
| Durability | 2,000 mating cycles min. | 500 mating cycles |
| Shell to Shell Conductivity | 100 mV drop max | 200 mV drop max |
| Contacts | Per AS39029 | Per AS39029 |

2M803 MATERIALS AND FINISHES

| | |
|-----------------------------------|-----------------------------------|
| Shells | Aluminum Alloy or Stainless Steel |
| Contacts | Copper Alloy, gold plated |
| Insulators | Polyphenylene Sulfide (PPS) |
| Contact Retention | Beryllium Copper Alloy |
| Grommet, Interfacial Seal, O-Ring | Fluorosilicone Rubber |



2M803 1/4 Turn Bayonet Coupling

Ordering Guide for 2M803 Crimp Receptacles & Plugs



| 1. SERIES | 2. SHELL STYLE | 3. SERVICE CLASS | 4. SHELL SIZE-INSERT AGGMT | 5. CONTACTS | 6. KEYING |
|-----------|----------------|------------------|----------------------------|-------------|-----------|
| 2M803-00X | -06 | NF | 6-7 | P | N |

2M803

| 1. SERIES | | | 2. SHELL STYLE | | 3. SERVICE CLASS | | | | |
|------------------|---|--|-------------------------------|-----------------|------------------|--------------------------|---|---------------------|--|
| Type | Part/PCB | Description | Part # | Description | Material | Part # | Description | RoHS | |
| CRIMP | PLUGS | | PLUGS | | ALUMINUM | C | Anodized (Non-conductive) | | |
| | 2M803-001 | Plug with Integral Backshell | -06 | Anti-Decoupling | | M | Electroless Nickel | | |
| | 2M803-002 | Plug with Accessory Threads | | | | NF | Olive Drab Cadmium | | |
| | RECEPTACLE | | RECEPTACLES | | | MT | Duralon (Ni PTFE) | | |
| | 2M803-003 | Receptacle with Integral Backshell | -07 | Jam Nut* | | ZN | Olive Drab Zinc Nickel | | |
| | 2M803-004 | Receptacle with Accessory Threads | -01 | In-Line | | ZNU | Black Zinc Nickel | | |
| 2M803-005 | Receptacle for Solder Cup or PCB Termination, with Standard Epoxy Potting | -02 | Flange Mount | BEN | | Black Electroless Nickel | | | |
| PCB/SOLDER | PCB/SOLDER RECEPTACLES | | PCB/SOLDER RECEPTACLES | | | STAINLESS STEEL | Z1 | Passivated | |
| | 2M803-015 | Receptacle with Solder Cup or PCB Termination with Special Sealing for Open Face (unmated) Water Immersion Requirements. 100% Leak Tested. To maintain a helium leak rate of 1x10 ⁻⁴ cc/sec. pressure differential from -65°C to 175°C. | -07 | Jam Nut* | | | ZL | Electrolytic Nickel | |
| | | | | | | | *add "-501" as a suffix to the Jam Nut Part number to include a Hex Nut instead of a Spanner Nut. | | |

| 4. SHELL SIZE-INSERT ARRANGEMENT |
|----------------------------------|
| See Table on pages 7-20 |

| 5. CONTACTS | | |
|-------------|----------|----------------------|
| Style | Part # | Description |
| CRIMP | P | Pin |
| | S | Socket |
| | A | Pin-Less Contacts |
| | B | Socket-Less Contacts |

| 6. KEYING | | |
|-----------|------|------|
| Part # | A° | B° |
| N | 150° | 210° |
| X | 75° | 210° |
| Y | 95° | 230° |
| Z | 140° | 275° |

| PCB/SOLDER RECEPTACLES | | |
|------------------------|----------|-------------------|
| Style | Part # | Description |
| PCB/SOLDER | P | Pin-PCB |
| | S | Socket-PCB |
| | E | Pin-Solder Cup |
| | F | Socket-Solder Cup |

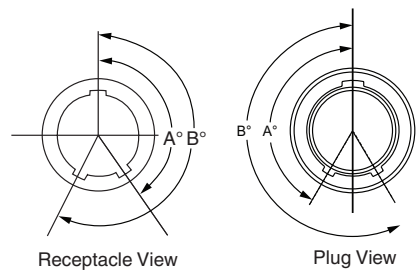

For additional assistance building a part number and for 3D models, please visit www.amphenol-aerospace.com to access our 2M configurator.

2M803 1/4 Turn Bayonet Coupling

Weights



SERIES 2M803 MAXIMUM CONNECTOR WEIGHT IN GRAMS

| Insert Arrangements | Cable Plug | Jam Nut Receptacle Crimp | Jam Nut Receptacle PCB | Flange Receptacle Crimp | Flange Receptacle PCB |
|---------------------|------------|--------------------------|------------------------|-------------------------|-----------------------|
| 5-3P | 3.6 | 3.6 | 3.9 | 2.9 | 3.3 |
| 5-3S | 3.7 | 3.7 | 4.0 | 3.1 | 3.4 |
| 6-1P | 4.4 | 4.4 | 4.6 | 3.1 | 3.5 |
| 6-1S | 4.5 | 4.5 | 4.7 | 3.2 | 3.6 |
| 6-4P | 4.7 | 3.7 | 4.1 | 3.1 | 3.6 |
| 6-4S | 4.7 | 4.0 | 4.2 | 3.2 | 3.7 |
| 6-7P | 5.1 | 4.8 | 5.3 | 3.3 | 4.4 |
| 6-7S | 5.1 | 5.1 | 5.5 | 3.6 | 4.4 |
| 7-1P | 5.7 | 5.9 | 5.8 | 4.4 | 4.7 |
| 7-1S | 5.9 | 6.2 | 5.9 | 4.7 | 5.1 |
| 7-10P | 6.9 | 7.4 | 8.1 | 5.0 | 6.5 |
| 7-10S | 7.4 | 7.8 | 8.4 | 5.4 | 6.6 |
| 8-2P | 8.6 | 8.9 | 9.9 | 6.6 | 8.6 |
| 8-2S | 9.4 | 9.7 | 10.7 | 7.4 | 9.4 |
| 8-13P | 7.9 | 8.3 | 9.2 | 5.9 | 7.9 |
| 8-13S | 8.7 | 8.9 | 9.7 | 6.6 | 8.1 |
| 8-200P | 8.9 | 9.2 | 10.2 | 6.9 | 8.9 |
| 8-200S | 9.6 | 9.9 | 10.9 | 6.9 | 9.6 |
| 9-4P | 9.2 | 9.6 | 10.6 | 6.6 | 9.2 |
| 9-4S | 9.6 | 9.9 | 10.9 | 6.9 | 9.6 |
| 9-19P | 9.2 | 9.1 | 10.6 | 7.0 | 9.9 |
| 9-19S | 10.2 | 10.1 | 11.2 | 8.1 | 10.2 |
| 9-200P | 9.1 | 9.5 | 10.5 | 7.2 | 9.1 |
| 9-200S | 10.2 | 10.6 | 11.6 | 8.3 | 10.2 |
| 9-201P | 9.2 | 9.6 | 10.6 | 7.3 | 10.3 |
| 9-201S | 9.8 | 10.1 | 11.7 | 8.4 | 10.3 |
| 10-5P | 13.4 | 14.1 | 15.0 | 10.6 | 13.9 |
| 10-5S | 14.9 | 15.5 | 17.5 | 12.0 | 15.3 |
| 10-26P | 11.7 | 12.3 | 14.3 | 8.8 | 12.8 |
| 10-26S | 13.4 | 13.6 | 15.1 | 10.1 | 13.1 |
| 10-200P | 12.5 | 13.2 | 15.2 | 9.7 | 13.0 |
| 10-200S | 14.0 | 14.6 | 16.6 | 11.1 | 14.4 |
| 10-201P | 12.9 | 13.5 | 15.5 | 10.0 | 13.3 |
| 10-201S | 14.4 | 15.1 | 17.1 | 11.6 | 14.9 |
| 10-202P | 12.4 | 13.1 | 15.1 | 9.6 | 11.8 |
| 10-202S | 14.0 | 14.6 | 16.6 | 11.1 | 14.4 |
| 12-2P | 15.5 | 16.4 | 19.1 | 11.4 | 16.9 |
| 12-2S | 17.2 | 18.0 | 20.8 | 13.1 | 18.6 |
| 12-3P | 16.5 | 17.4 | 20.1 | 12.4 | 17.9 |
| 12-3S | 18.3 | 19.1 | 21.9 | 14.2 | 19.7 |
| 12-7P | 16.7 | 17.6 | 20.4 | 12.7 | 18.2 |
| 12-7S | 19.4 | 20.2 | 23.0 | 15.3 | 20.8 |
| 12-37P | 15.0 | 15.8 | 18.6 | 10.9 | 16.4 |
| 12-37S | 16.6 | 17.5 | 19.6 | 12.4 | 16.7 |
| 12-200P | 15.6 | 16.5 | 19.3 | 11.6 | 17.1 |
| 12-200S | 17.9 | 18.8 | 21.6 | 13.9 | 19.4 |
| 12-201P | 15.7 | 16.6 | 19.4 | 11.7 | 17.2 |
| 12-201S | 18.2 | 19.0 | 21.8 | 14.1 | 19.6 |
| 14-5P | 22.2 | 23.5 | 27.7 | 17.3 | 25.5 |
| 14-5S | 24.8 | 26.1 | 29.3 | 19.8 | 25.1 |
| 14-55P | 19.6 | 20.9 | 25.1 | 14.6 | 22.9 |
| 14-55S | 22.6 | 23.9 | 27.1 | 14.6 | 23.9 |

2M803

E

2M803 1/4 Turn Bayonet Coupling Plug

2M803-001-06 and 2M803-002-06

2M803-001-06

2M803-002-06

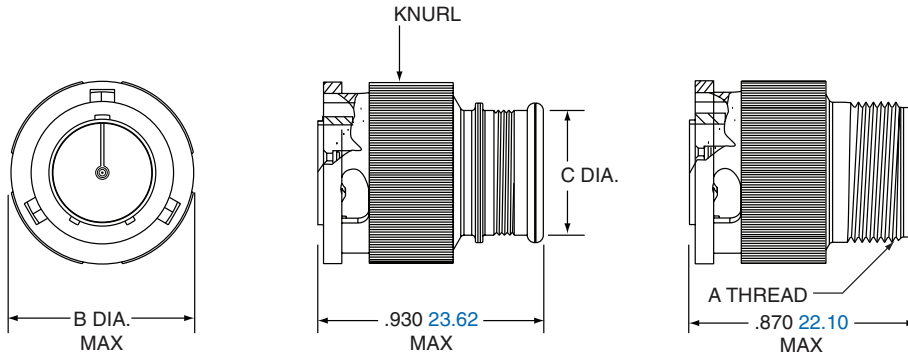

| Shell Size | A Thread UNEF-2A | B Dia. Max | | C Dia. | |
|------------|---------------------|------------|-------|--------|-------|
| | | in. | mm. | in. | mm. |
| 5 | .2500-32 | .475 | 12.07 | .245 | 6.22 |
| 6 | .3125-32 | .540 | 13.72 | .290 | 7.37 |
| 7 | .4375-28 | .620 | 15.75 | .390 | 9.91 |
| 8 | .5000-28 | .675 | 17.15 | .450 | 11.43 |
| 9 | .5625-24 | .745 | 18.92 | .500 | 12.70 |
| 10 | .6250-24 | .812 | 20.63 | .562 | 14.28 |
| 12 | .6875-24 | .894 | 22.71 | .650 | 16.51 |
| 14 | .9375-20 | 1.060 | 26.92 | .800 | 20.32 |
| 15 | .9375-20 | 1.120 | 28.45 | 1.035 | 26.29 |

2M803 1/4 Turn Bayonet Coupling Jam Nut

2M803-003-07 and 2M803-004-07

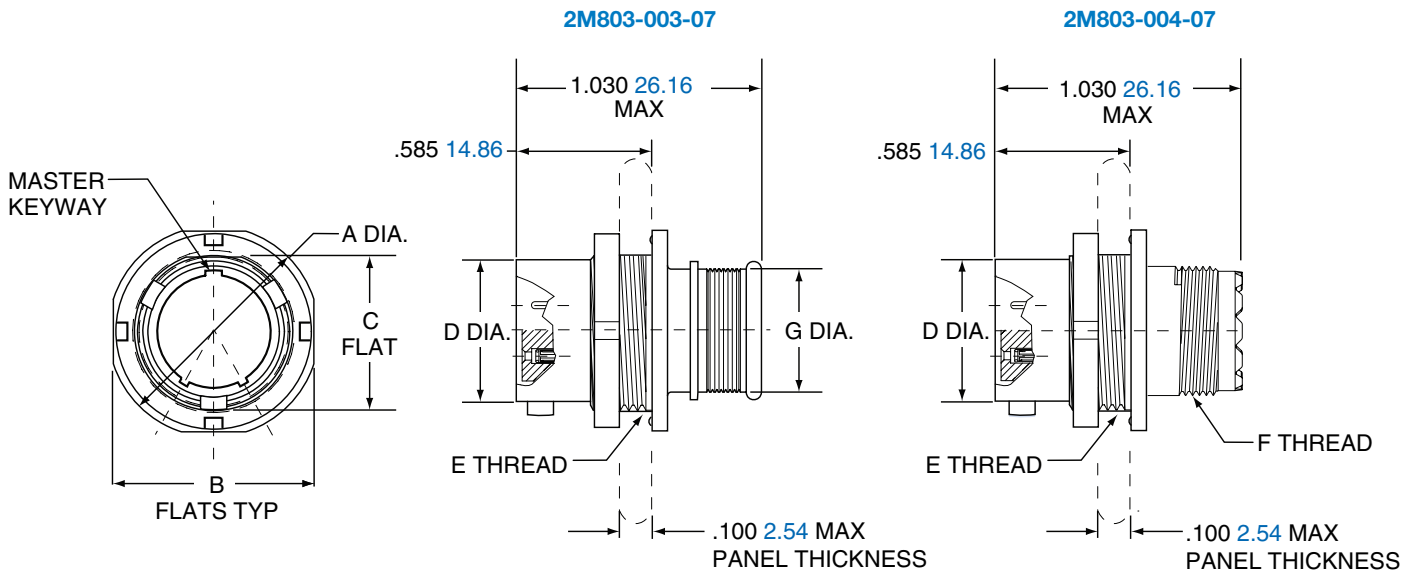

| Shell Size | A Dia. | | B Flat | | C Flat | | D Dia. | | E Thread | F Thread | G Dia. | |
|------------|--------|-------|--------|-------|--------|-------|--------|-------|------------------|------------------|--------|-------|
| | in. | mm | in. | mm. | in. | mm | in. | mm. | | | in. | mm. |
| 5 | .575 | 14.61 | .545 | 13.84 | .350 | 8.89 | .300 | 7.62 | .3750-32 UNEF-2A | .2500-32 UNEF-2A | .245 | 6.30 |
| 6 | .635 | 16.13 | .595 | 15.11 | .410 | 10.41 | .362 | 9.19 | .4375-28 UNEF-2A | .3125-32 UNEF-2A | .290 | 7.44 |
| 7 | .755 | 19.18 | .723 | 18.36 | .536 | 13.61 | .436 | 11.07 | .5625-32 UN-2A | .4375-28 UNEF-2A | .390 | 9.86 |
| 8 | .830 | 21.08 | .790 | 20.11 | .593 | 15.10 | .498 | 12.65 | .6250-28 UN-2A | .5000-28 UNEF-2A | .450 | 11.38 |
| 9 | .830 | 21.08 | .790 | 20.07 | .596 | 15.14 | .561 | 14.25 | .6250-28 UN-2A | .5625-24 UNEF-2A | .500 | 12.78 |
| 10 | .955 | 24.26 | .925 | 23.51 | .721 | 18.31 | .635 | 16.13 | .7500-28 UN-2A | .6250-24 UNEF-2A | .562 | 14.30 |
| 12 | 1.078 | 27.38 | 1.044 | 26.52 | .845 | 21.46 | .714 | 18.14 | .8750-28 UN-2A | .6875-24 UNEF-2A | .650 | 16.71 |
| 14 | 1.264 | 32.11 | 1.230 | 31.24 | 1.022 | 25.96 | .865 | 21.97 | 1.0625-20 UN-2A | .9375-20 UNEF-2A | .805 | 20.40 |
| 15 | 1.322 | 33.58 | 1.287 | 32.69 | 1.093 | 27.76 | .924 | 23.47 | 1.1250-28 UN-2A | .9375-20 UNEF-2A | .850 | 21.67 |

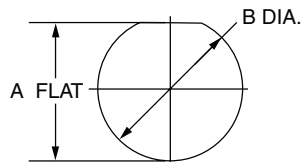

PANEL CUTOUT FOR JAM NUT RECEPTACLE

| Shell Size | A Flat | | B Dia | |
|------------|--------------|---------------|-------|-------|
| | in. ±.002 | mm. ± 0.05 | in. | mm. |
| 5 | .355 | 9.02 | .382 | 9.70 |
| 6 | .415 | 10.54 | .445 | 11.30 |
| 7 | .541 | 13.74 | .572 | 14.53 |
| 8 | .601 | 15.27 | .635 | 16.13 |
| 9 | .601 | 15.27 | .643 | 16.33 |
| 10 | .729 | 18.52 | .760 | 18.29 |
| 12 | .850 | 21.59 | .885 | 22.48 |
| 14 | 1.031 | 23.19 | 1.072 | 27.23 |

2M803 Bayonet Coupling Flange Mount

2M803-003-02 and 2M803-004-02

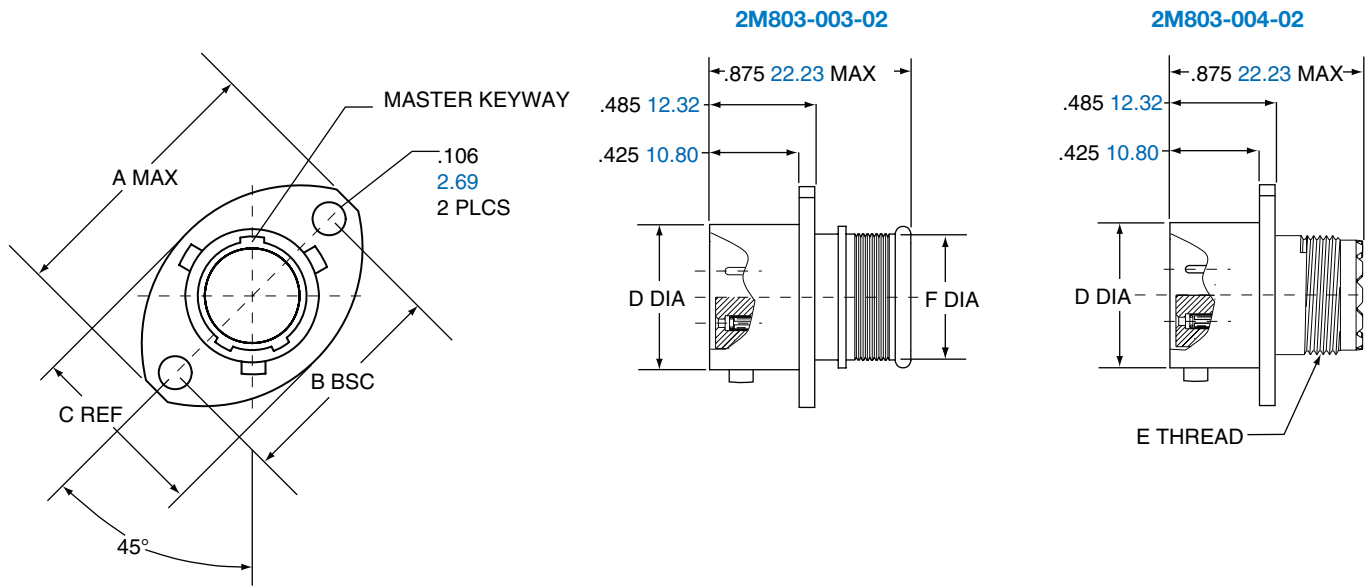

| Shell Size | A Max. | | B BSC. | | C Ref. | | D Dia. | | E Thread UNEF-2A | F Dia. | |
|------------|--------|-------|--------|-------|--------|-------|--------|-------|---------------------|--------|-------|
| | in. | mm. | in. | mm. | in. | mm. | in. | mm. | | in. | mm. |
| 5 | .710 | 18.03 | .513 | 13.03 | .460 | 11.68 | .300 | 7.62 | .2500-32 | .245 | 6.30 |
| 6 | .788 | 20.02 | .598 | 15.19 | .522 | 13.26 | .362 | 9.19 | .3125-32 | .290 | 7.44 |
| 7 | .895 | 22.73 | .708 | 17.98 | .590 | 14.99 | .436 | 11.07 | .4375-28 | .390 | 9.86 |
| 8 | 1.154 | 29.31 | .964 | 24.49 | .668 | 16.97 | .500 | 12.70 | .5000-28 | .450 | 11.38 |
| 9 | 1.210 | 30.73 | 1.017 | 25.83 | .721 | 18.31 | .561 | 14.25 | .5625-24 | .500 | 12.78 |
| 10 | 1.291 | 32.79 | 1.101 | 27.97 | .795 | 20.19 | .635 | 16.13 | .6250-24 | .562 | 14.30 |
| 12 | 1.395 | 35.43 | 1.204 | 30.58 | .874 | 22.20 | .714 | 18.14 | .6875-24 | .650 | 16.71 |
| 14 | 1.550 | 39.37 | 1.280 | 32.51 | 1.050 | 26.67 | .865 | 21.97 | .9375-20 | .805 | 20.40 |

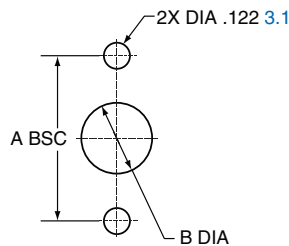

FLANGE MOUNT PANEL CUTOUTS

| Shell Size | A BSC | | B Dia | |
|------------|-------|-------|-------|-------|
| | in. | mm. | in. | mm. |
| 5 | .513 | 13.03 | .365 | 9.25 |
| 6 | .598 | 15.19 | .430 | 10.92 |
| 7 | .708 | 17.98 | .520 | 13.21 |
| 8 | .964 | 17.98 | .592 | 15.04 |
| 9 | 1.017 | 25.83 | .645 | 16.38 |
| 10 | 1.101 | 27.97 | .726 | 18.44 |
| 12 | 1.204 | 30.58 | .832 | 21.13 |
| 14 | 1.280 | 32.51 | .945 | 24.00 |

2M803 1/4 Turn Bayonet Coupling In-Line

2M803-003-01 and 2M803-004-01

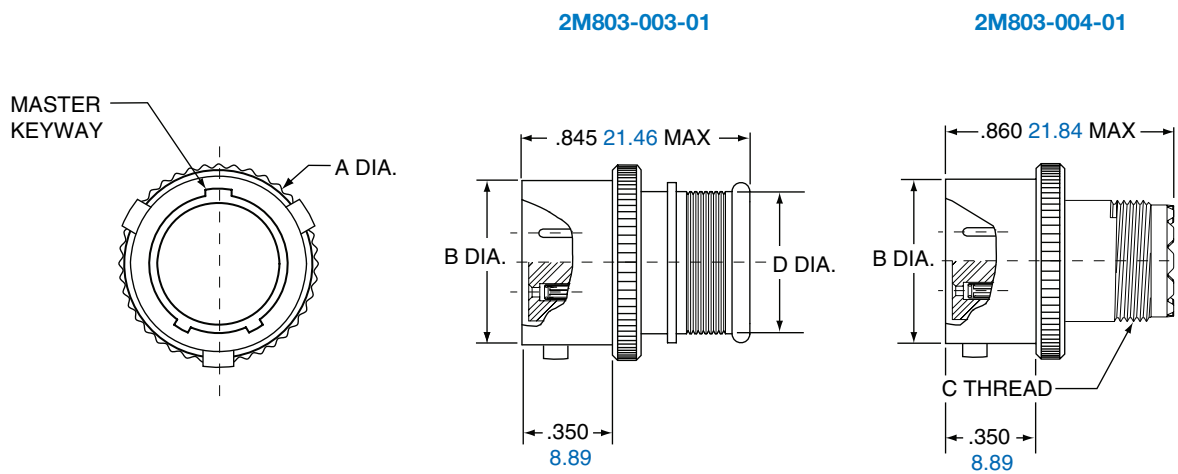

| Shell Size | A Max. | | B Dia. | | C Thread UNEF-2A | D Dia. | |
|------------|--------|-------|--------|-------|---------------------|--------|-------|
| | in. | mm. | in. | mm. | | in. | mm. |
| 5 | .385 | 9.78 | .300 | 7.62 | .2500-32 | .245 | 6.30 |
| 6 | .465 | 11.81 | .362 | 9.19 | .3125-32 | .290 | 7.44 |
| 7 | .485 | 12.32 | .438 | 11.13 | .4375-28 | .390 | 9.86 |
| 8 | .566 | 14.38 | .498 | 12.65 | .5000-28 | .450 | 11.38 |
| 9 | .658 | 16.71 | .564 | 14.33 | .5625-24 | .500 | 12.78 |
| 10 | .720 | 18.29 | .636 | 16.15 | .6250-24 | .562 | 14.30 |
| 12 | .810 | 20.57 | .713 | 18.11 | .6875-24 | .650 | 16.71 |
| 14 | 1.027 | 26.09 | .865 | 21.97 | .9375-20 | .805 | 20.40 |
| 15 | 1.027 | 26.09 | .924 | 23.47 | .9375-20 | .850 | 21.67 |

2M803

E

2M803 1/4 Turn PCB Bayonet Coupling

Flange Mount & Jam Nut Receptacle 2M803-005-02 and 07

2M803-005-02

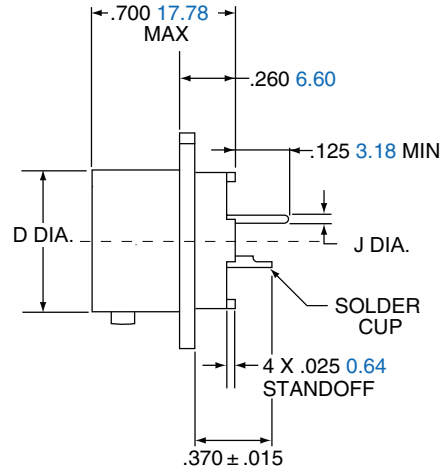
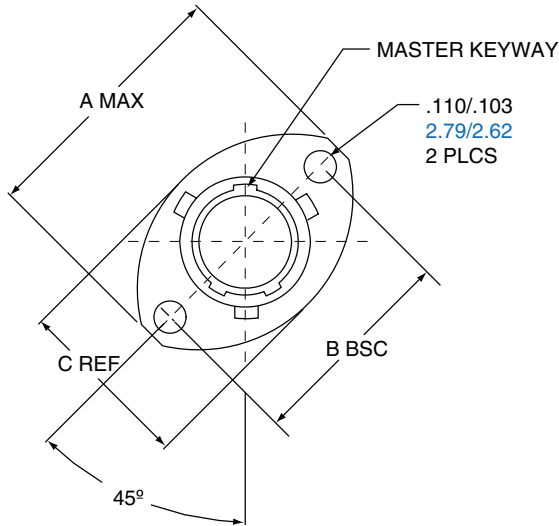

2M803-005-07

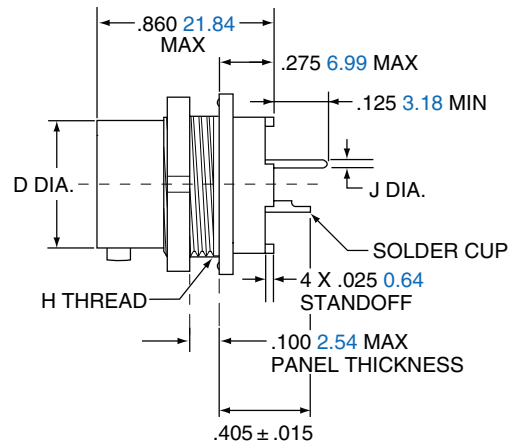
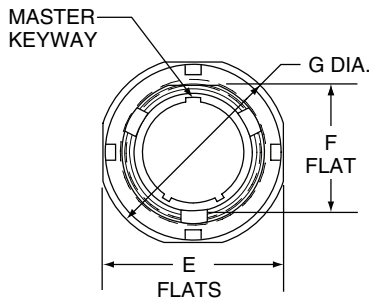

| Shell Size | A Max. | | B BSC. | | C Ref. | | D Dia. | | E Flats | | F Flats | | G Dia. | | H Thread | J Dia. Tail Dia. |
|------------|--------|-------|--------|-------|--------|-------|--------|-------|---------|-------|---------|-------|--------|-------|------------------|------------------------------------|
| | in. | mm | in. | mm. | in. | mm | in. | mm. | in. | mm. | in. | mm. | in. | mm. | | |
| 5 | .710 | 18.03 | .513 | 13.03 | .460 | 11.68 | .300 | 7.62 | .545 | 13.84 | .350 | 8.89 | .575 | 14.61 | .3750-32 UNEF-2A | #23 .018/.022 0.46/0.56 |
| 6 | .788 | 20.02 | .598 | 15.19 | .522 | 13.26 | .362 | 9.19 | .595 | 15.11 | .410 | 10.42 | .635 | 16.13 | .4375-28 UNEF-2A | #20/20HD .025/.027 0.64/0.69 |
| 7 | .895 | 22.73 | .708 | 17.98 | .590 | 14.99 | .436 | 11.07 | .723 | 18.36 | .536 | 13.61 | .755 | 19.18 | .5625-32 UN-2A | #16 .060/.064 1.52/1.63 |
| 8 | 1.154 | 29.31 | .964 | 24.49 | .665 | 16.97 | .500 | 12.70 | .790 | 20.07 | .593 | 15.10 | .830 | 21.08 | .6250-28 UN-2A | #12 .092/.096 2.34/2.44 |
| 9 | 1.210 | 30.73 | 1.017 | 25.83 | .721 | 18.31 | .561 | 14.25 | .790 | 20.07 | .596 | 15.14 | .830 | 21.08 | .6250-28 UN-2A | |
| 10 | 1.291 | 32.79 | 1.101 | 27.97 | .795 | 20.19 | .635 | 16.13 | .925 | 23.51 | .721 | 23.49 | .955 | 24.26 | .7500-28 UN-2A | |
| 12 | 1.395 | 35.43 | 1.204 | 30.58 | .874 | 22.20 | .714 | 18.14 | 1.044 | 26.52 | .845 | 21.46 | 1.078 | 27.38 | .8750-28 UN-2A | |
| 14 | 1.550 | 39.37 | 1.280 | 32.51 | 1.050 | 26.67 | .865 | 21.97 | 1.230 | 31.24 | 1.022 | 25.96 | 1.264 | 32.11 | 1.0625-20 UN-2A | |
| 15 | N/A | N/A | N/A | N/A | N/A | N/A | .924 | 23.47 | 1.287 | 32.69 | 1.093 | 27.76 | 1.322 | 33.58 | 1.1250-28 UN-2A | |

2M803 Protection Caps

Ordering Guide for Protection Caps 2M660-082 and 2M660-083



2M803 ¼ Turn Bayonet Protective Caps are available in plug and receptacle versions. Protective caps keep the connector interface dry and clean while not in use. Caps come in a variety of materials, lanyard styles and lengths to accommodate specific design requirements.

2M803 FEATURES INCLUDE:

- Aluminum or Stainless Steel Bodies
- Rubber Gaskets for Environmental Sealing
- Stainless Steel Fittings
- Variety of attachments



| 1. SERIES | 2. SERVICE CLASS | 3. ATTACHMENT TYPE | 4. SHELL SIZE | 5. ATTACHMENT CODE | 6. ATTACHMENT LENGTH IN INCHES |
|-----------|------------------|--------------------|---------------|--------------------|--------------------------------|
| 2M660-08X | -M | -G | 6 | 04 | -5 |

| 1. SERIES | |
|-----------|-----------------------------------|
| Part # | Description |
| 2M660-082 | Protection Caps 2M803 Plugs |
| 2M660-083 | Protection Caps 2M803 Receptacles |

| 2. SERVICE CLASS | | | |
|------------------|--------|---------------------------------|------|
| Material | Part # | Description | RoHS |
| ALUMINUM | -C | Black Anodized (Non-conductive) | |
| | -M | Electroless Nickel | |
| | -NF | Olive Drab Cadmium | |
| | -MT | Durmalon (Ni PTFE) | |
| | -ZN | Olive Drab Zinc Nickel | |
| | -ZNU | Black Zinc Nickel | |
| STAINLESS STEEL | -Z1 | Passivated | |
| | -ZL | Electrolytic Nickel | |

| 3. ATTACHMENT TYPE | | |
|--------------------|--------|--|
| | Part # | Description |
| | -G | Nylon Rope |
| | -H | Stainless Steel Wire Rope, Teflon® Jacket |
| | -N | No Attachment |
| | -S | Stainless Steel Sash Chain |
| | -SK | Nylon Rope With Slip Knot |
| | -T | Stainless Steel Wire Rope, No Jacket |
| | -U | Stainless Steel Wire Rope, Polyurethane Jacket |

| 4. SHELL SIZE | | 5. ATTACHMENT CODE | |
|---------------|--|--|----------------|
| Part # | | Omit for attachment Types N (No Attachment) and SK (Slip Knot) | For Shell Size |
| 5 | | 01 -.126 (3.20) I.D. | |
| 6 | | 02 -.145 (3.68) I.D. | |
| 7 | | 04 -.188 (4.78) I.D. | |
| 8 | | 06 -.197 (5.00) I.D. | |
| 9 | | 14 -.385 (9.78) I.D. | 5 |
| 10 | | 15 -.445 (11.30) I.D. | 6 |
| 12 | | 16 -.570 (14.48) I.D. | 7 |
| 14 | | 17 -.635 (16.13) I.D. | 8, 9 |
| 15 | | 19 -.885 (22.48) I.D. | 10, 12 |
| | | 20 -1.070 (27.17) I.D. | 14 |
| | | 22 -1.210 (32.38) I.D. | 15 |
| | | 50 -.420 (10.67) I.D. | |
| | | 52 -.480 (12.19) I.D. | |
| | | 54 -.635 (16.13) I.D. | |
| | | 56 -.745 (18.92) I.D. | |
| | | 58 -.885 (22.48) I.D. | |
| | | 60 -1.010 (25.65) I.D. | |
| | | 64 -1.125 (28.58) I.D. | |
| | | 68 -1.345 (34.16) I.D. | |

| 6. ATTACHMENT LENGTH IN INCHES | |
|--|-------------|
| -5 | Inch Length |
| Omit for attachment Type N (No Attachment) Example "-5" equals five inch length | |

| 5. ADDITIONAL ATTACHMENT CODE | |
|--|------------------------|
| Omit for attachment Types N (No Attachment) and SK (Slip Knot) | |
| | 18 -.695 (17.65) I.D. |
| | 21 -.885 (22.48) I.D. |
| | 23 -1.275 (32.38) I.D. |
| | 24 -1.375 (34.92) I.D. |
| | 25 -1.530 (38.86) I.D. |

Assembly Instructions for Protection Cap, see page 100.

2M803 1/4 Turn Bayonet Coupling

Protective Cap 2M660-082 and 2M660-083

2M660-082

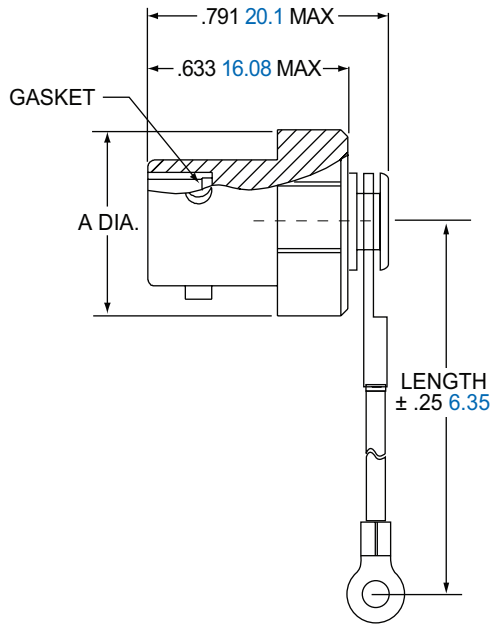

2M660-083

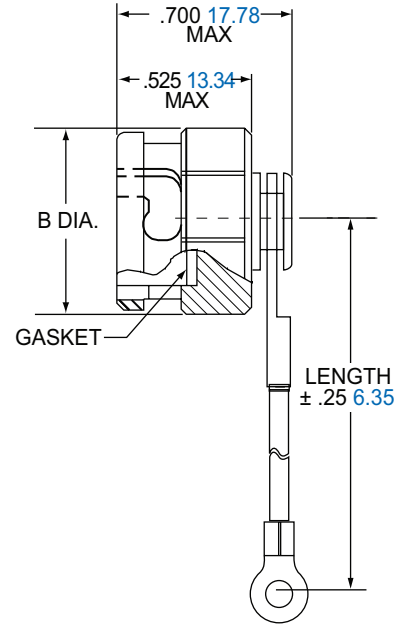

| Shell Size | A Max. | |
|------------|--------|-------|
| | in. | mm. |
| 5 | .620 | 15.75 |
| 6 | .620 | 15.75 |
| 7 | .620 | 15.75 |
| 8 | .690 | 17.53 |
| 9 | .760 | 19.30 |
| 10 | .850 | 21.59 |
| 12 | .940 | 23.88 |
| 14 | 1.170 | 29.72 |
| 15 | 1.230 | 31.24 |

| Shell Size | B Max. | |
|------------|--------|-------|
| | in. | mm. |
| 6 | .541 | 13.74 |
| 7 | .618 | 15.70 |
| 9 | .743 | 18.87 |
| 12 | .892 | 22.66 |

| MATERIALS | |
|----------------|-----------------------------------|
| Cover | Aluminum alloy or stainless steel |
| Gasket | Fluorosilicone rubber |
| Wire, Hardware | Stainless steel, passivated |

2M Series 801 Dual-Start Acme Threads

General Information



Page Guide

| | |
|----------------------------------|---------|
| Order | F-69 |
| Weight | F-70 |
| Plugs | F-71 |
| Jam Nut | F-72 |
| Square Flange | F-73 |
| In-Line | F-74 |
| Jam Nut & Sq. Flange | F-75 |
| PCB Right Angle Jam Nut | F-76 |
| PCB Double Flange .. | F-77 |
| Protection Caps | F-78-80 |

Amphenol's 2M Micro38999 Connector Series... The New Aerospace Standard

Averaging less than half the size and weight of their 38999 ancestors, Amphenol's 2M Micro38999 series are an easy and inexpensive way to take weight out of your system. 2M meet or exceed most environmental and performance requirements listed in MIL-DTL-38999, so modernizing your equipment doesn't mean sacrificing ruggedness. With almost 2,000,000 configurations in every termination style and a full complement of accessories available right out of the catalog, customization has never been easier. Smarter, faster and smaller: Amphenol's 2M... the only connector you'll ever need.

2M801 Features

- Heavy Dual-Start ACME Thread
- Most durable of the 2M series
- Up to 2,000 mating cycles
- Two Plug Styles
- Ratcheting Anti-Decoupling Plug
- Free-Spinning Plug



Why 2M801?

2M801 is generally considered a legacy series and is mostly inactive for new designs. Its successor, the 2M805 series, has a number of important improvements, including a triple-start thread (which reduces the number of turns it takes to fully mate the connectors) and an EMI band (which increases shell-to-shell conductivity and greatly improves signal shielding). You should choose 2M801 if you're looking to maintain compatibility or interoperability with existing technology or cables.

2M801

| 2M VS 38999 | | |
|-----------------------------|--|--|
| SPECIFICATION | 2M801 | MIL-DTL 38999 |
| Signal Count | 1 to 130 | 1 to 187 |
| Insulation Resistance | 5,000 megaohms min | 5,000 megaohms min |
| Operating Temperature | -65°C to +175°C | -65°C to +175°C |
| Shock | 300 G ± 15 | 300 G ± 15 |
| Vibration | "43.9 G Random 60.0 G Sine" | "43.9 G Random 60.0 G Sine" |
| Shielding Effectiveness | "55 dB min. from 100 MHz to 1000 MHz" | "50 dB min. from 100 MHz to 1000 MHz" |
| Durability | 500 mating cycles | 500 mating cycles |
| Shell to Shell Conductivity | 2.5 mV drop max | 2.5 mV drop max |
| Contacts | Per AS39029 | Per AS39029 |

| 2M801 MATERIALS AND FINISHES | |
|-----------------------------------|-----------------------------------|
| Shells | Aluminum Alloy or Stainless Steel |
| Contacts | Copper Alloy, gold plated |
| Insulators | Polyphenylene Sulfide (PPS) |
| Contact Retention | Beryllium Copper Alloy |
| Grommet, Interfacial Seal, O-Ring | Fluorosilicone Rubber |



2M801 Dual-Start ACME Threads

Ordering Guide for 2M801



| 1. | 2. | 3. | 4. | 5. | 6. |
|-----------|-------------|---------------|-------------------------|----------|--------|
| SERIES | SHELL STYLE | SERVICE CLASS | SHELL SIZE-INSERT AGGMT | CONTACTS | KEYING |
| 2M801-007 | -01 | C | 5-3 | P | A |

| 1. SERIES | | |
|-----------|-----------------------------------|----------------------------------|
| Type | Part # | Description |
| CRIMP | PLUG | |
| | 2M801-007 | Plug with Integral Backshell |
| | 2M801-008 | Plug with Accessory Threads |
| | RECEPTACLE | |
| | 2M801-009 | Receptacle with Banding Platform |
| 2M801-010 | Receptacle with Accessory Threads | |

| PCB/SOLDER | | |
|-------------|-----------|---|
| Type | Part # | Description |
| PCB/ SOLDER | 2M801-011 | Receptacle for Solder Cup or PCB Termination with Epoxy Potting |
| | 2M801-033 | Receptacle with Solder Cup or PCB Termination with Special Sealing for Open Face (unmated) Water Immersion Requirements. 100% Leak Tested. To maintain a helium leak rate of 1-10 ⁻⁴ cc/sec. pressure differential from -55°C to 175° C. |
| | 2M801-075 | Receptacle with Standoff Flange for Mechanical PCB Strain Relief |

| RIGHT ANGLE PCB | | |
|-----------------|-----------|-------------------------------|
| Type | Part # | Description |
| | 2M801-023 | Receptacle w/ Right Angle PCB |

| 2. SHELL STYLE | |
|-------------------|---|
| Part # | Description |
| PLUG | |
| -16 | Anti-Decoupling |
| -26 | Self-Locking Ratchet |
| RECEPTACLE | |
| -01 | In-Line** |
| -02 | Square Flange |
| -07 | Jam Nut |
| PCB/SOLDER | |
| -02 | Square Flange |
| -07 | Jam Nut* |
| -12 | Square Flange w/non-locking Clinch Nuts |
| -22 | Square Flange w/ locking Clinch Nuts |

| RIGHT ANGLE PCB | |
|-----------------|-------------|
| Part # | Description |
| -07 | Jam Nut* |

*add "-501" as a suffix to the Jam Nut Part number to include a Hex Nut instead of a Spanner Nut.

| 3. SERVICE CLASS | | | |
|------------------|--------|---------------------------|------|
| Material | Part # | Description | RoHS |
| ALUMINUM | C | Anodized (Non-conductive) | |
| | M | Electroless Nickel | |
| | NF | Olive Drab Cadmium | |
| | MT | Durmalon (Ni PTFE) | |
| | ZN | Olive Drab Zinc Nickel | |
| | ZNU | Black Zinc Nickel | |
| | BEN | Black Electroless Nickel | |
| STAINLESS STEEL | Z1 | Passivated | |
| | ZL | Electrolytic Nickel | |

| 6. KEYING | | |
|-----------|------|------|
| Part # | A° | B° |
| A | 150° | 210° |
| B | 75° | 210° |
| C | 95° | 230° |
| D | 140° | 275° |
| E | 75° | 275° |
| F | 95° | 210° |

4. SHELL SIZE-INSERT ARRANGEMENT

See Table on pages 7-20

| 5. CONTACTS | | |
|-------------------|--------|----------------------|
| Style | Part # | Description |
| CRIMP | P | Pin |
| | S | Socket |
| | A | Pin-Less Contacts |
| | B | Socket-Less Contacts |
| PCB/SOLDER | | |
| PCB/SOLDER | P | Pin-PCB |
| | S | Socket-PCB |
| | E | Pin-Solder Cup |
| | F | Socket-Solder Cup |

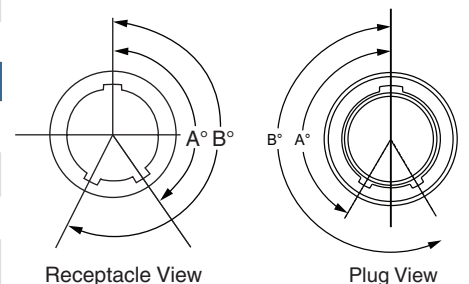

2M801 High Speed Dual-Start ACME Threads

Ordering Guide for High Speed 2M801



The 2M801 High Speed Series of connectors is ideal for use in USB 2.0, eSATA and other high speed databus applications. These connectors utilize Teflon-based inserts that are optimized for high speed capability. Multiple standard insert arrangements are available. Ideal for applications where space is limited and a high speed interconnect is needed. This series features plugs with or without anti-decoupling mechanisms and a Dual-Start ACME thread that provides full mating in 1 1/2 turns. Plugs and receptacles are provided in two different shell styles to accommodate the attachment of backshell with rear accessory threads or with integral banding platform. The integral banding platform allows for use of EMI shielding attachments and/or overmolding. Contact termination styles include Crimp, PC Tail and Solder Cup.

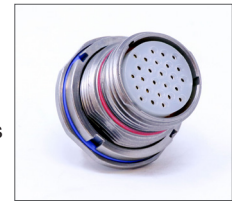

| 1. | 2. | 3. | 4. | 5. | 6. |
|-----------|-------------|---------------|-------------------------|----------|--------|
| SERIES | SHELL STYLE | SERVICE CLASS | SHELL SIZE-INSERT AGGMT | CONTACTS | KEYING |
| 2M801-037 | -01 | M | 7-10 | P | A |

1. SERIES

| Type | Part # | Description |
|-------|-------------------|-----------------------------------|
| CRIMP | PLUG | |
| | 2M801-036 | Plug with Integral Backshell |
| | 2M801-039 | Plug with Accessory Threads |
| | RECEPTACLE | |
| | 2M801-037 | Receptacle with Banding Platform |
| | 2M801-040 | Receptacle with Accessory Threads |

PCB/SOLDER

| Type | Part # | Description |
|------------|-----------|---|
| PCB/SOLDER | 2M801-038 | Receptacle for Solder Cup or PCB Termination with Epoxy Potting |

2. SHELL STYLE

| Part # | Description |
|-------------------|----------------------|
| PLUG | |
| -16 | Anti-Decoupling |
| -26 | Self-Locking Ratchet |
| RECEPTACLE | |
| -01 | In-Line** |
| -02 | Square Flange |
| -07 | Jam Nut |

**add "-501" as a suffix to the Jam Nut Part number to include a Hex Nut instead of a Spanner Nut.

3. SERVICE CLASS

| Material | Part # | Description | RoHS |
|-----------------|--------|------------------------|------|
| ALUMINUM | M | Electroless Nickel | |
| | NF | Olive Drab Cadmium | |
| | MT | Durmalon (Ni PTFE) | |
| | ZN | Olive Drab Zinc Nickel | |
| | ZNU | Black Zinc Nickel | |
| STAINLESS STEEL | Z1 | Passivated | |

4. SHELL SIZE-INSERT ARRANGEMENT

| | |
|-------|--|
| 7-10 | |
| 9-19 | |
| 10-26 | |

5. CONTACTS

| Style | Part # | Description |
|-------|--------|----------------------|
| CRIMP | P | Pin |
| | S | Socket |
| | A | Pin-Less Contacts |
| | B | Socket-Less Contacts |

6. KEYING

| Part # | A° | B° |
|--------|------|------|
| A | 150° | 210° |
| B | 75° | 210° |
| C | 95° | 230° |
| D | 140° | 275° |
| E | 75° | 275° |
| F | 95° | 210° |

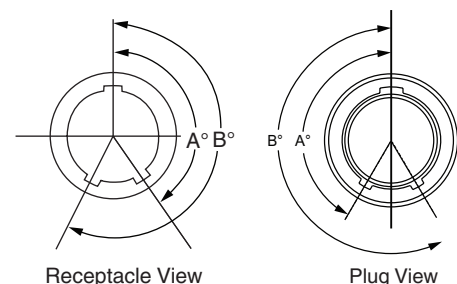

For additional assistance building a part number and for 3D models, please visit www.amphenol-aerospace.com to access our 2M configurator.

Contact Amphenol Aerospace for more information at 800-678-0141 • www.amphenol-aerospace.com

2M801

F

2M Series 801 Dual-Start Acme Threads

Connector Weights

SERIES 2M801 MAXIMUM CONNECTOR WEIGHT IN GRAMS

| Insert Arrg. | Plug | Jam Nut Recept. Crimp | Jam Nut Recept. PCB | Sq. Flange Recept. Crimp | Sq. Flange Recept. PCB | Insert Arrg. | Plug | Jam Nut Recept. Crimp | Jam Nut Recept. PCB | Sq. Flange Recept. Crimp | Sq. Flange Recept. PCB |
|--------------|------|-----------------------|---------------------|--------------------------|------------------------|--------------|------|-----------------------|---------------------|--------------------------|------------------------|
| 5-3P | 4.4 | 3.4 | 3.6 | 2.0 | 2.2 | 10-201S | 16.7 | 13.5 | 14.4 | 15.0 | 11.7 |
| 5-3S | 4.5 | 3.5 | 3.7 | 2.0 | 2.4 | 10-202P | 14.9 | 11.7 | 12.6 | 13.2 | 9.9 |
| 6-1P | 5.6 | 4.3 | 4.6 | 2.7 | 2.9 | 10-202S | 16.3 | 13.1 | 14.0 | 14.6 | 11.3 |
| 6-1S | 5.9 | 4.6 | 4.9 | 3.0 | 3.2 | 13-2P | 18.9 | 17.2 | 17.2 | 17.2 | 15.1 |
| 6-4P | 5.6 | 4.3 | 4.6 | 2.7 | 2.9 | 13-2S | 20.4 | 18.7 | 18.7 | 18.7 | 16.6 |
| 6-4S | 5.8 | 4.5 | 4.7 | 2.8 | 3.0 | 13-3P | 19.8 | 18.1 | 18.1 | 18.1 | 16.0 |
| 6-7P | 5.4 | 4.1 | 4.6 | 2.9 | 3.4 | 13-3S | 21.4 | 19.7 | 19.7 | 19.7 | 17.6 |
| 6-7S | 5.6 | 4.4 | 4.7 | 3.2 | 3.5 | 13-7P | 20.0 | 18.3 | 18.3 | 18.3 | 16.2 |
| 7-1P | 7.8 | 6.5 | 7.2 | 4.5 | 5.2 | 13-7S | 22.4 | 20.7 | 20.7 | 20.7 | 18.6 |
| 7-1S | 8.3 | 7.0 | 7.7 | 5.0 | 5.7 | 13-37P | 18.4 | 16.7 | 16.7 | 16.7 | 14.6 |
| 7-10P | 7.6 | 6.3 | 7.7 | 4.3 | 5.0 | 13-37S | 19.9 | 17.6 | 17.6 | 17.6 | 15.5 |
| 7-10S | 8.0 | 6.7 | 7.0 | 4.7 | 5.2 | 13-200P | 19.0 | 17.3 | 17.3 | 17.3 | 15.2 |
| 8-2P | 8.9 | 7.7 | 7.2 | 5.6 | 6.8 | 13-200S | 21.1 | 19.4 | 19.4 | 19.4 | 17.3 |
| 8-2S | 9.6 | 8.4 | 8.7 | 6.3 | 7.5 | 13-201P | 19.1 | 17.4 | 17.4 | 17.4 | 15.3 |
| 8-13P | 8.3 | 7.1 | 9.4 | 5.0 | 6.2 | 13-201S | 21.3 | 19.6 | 19.6 | 19.6 | 17.5 |
| 8-13S | 8.9 | 7.6 | 8.1 | 5.6 | 6.5 | 16-5P | 28.5 | 22.6 | 24.4 | 25.4 | 23.0 |
| 8-200P | 9.2 | 8.0 | 8.5 | 5.9 | 7.1 | 16-5S | 31.2 | 25.3 | 28.1 | 28.1 | 25.7 |
| 8-200S | 9.8 | 8.6 | 9.0 | 6.5 | 7.7 | 16-12P | 29.2 | 23.3 | 26.1 | 26.1 | 23.7 |
| 9-4P | 10.9 | 8.7 | 10.7 | 7.6 | 8.6 | 16-12S | 32.5 | 26.6 | 29.4 | 29.4 | 27.0 |
| 9-4S | 11.8 | 10.6 | 11.6 | 8.5 | 9.5 | 16-55P | 26.5 | 20.6 | 24.3 | 24.3 | 21.9 |
| 9-19P | 10.1 | 7.9 | 9.2 | 5.8 | 7.1 | 16-55S | 29.2 | 23.3 | 26.1 | 26.1 | 23.7 |
| 9-19S | 10.9 | 8.7 | 9.7 | 6.6 | 7.6 | 17-7P | 29.8 | 27.0 | 29.4 | 29.4 | 25.2 |
| 9-200P | 10.4 | 9.2 | 10.2 | 7.1 | 8.1 | 17-7S | 33.0 | 30.2 | 32.6 | 32.6 | 28.4 |
| 9-200S | 11.4 | 10.2 | 11.2 | 8.1 | 9.1 | 17-14P | 32.6 | 29.8 | 32.2 | 32.2 | 28.0 |
| 9-201P | 9.6 | 8.4 | 9.4 | 6.6 | 7.6 | 17-14S | 32.3 | 29.5 | 31.9 | 31.9 | 27.7 |
| 9-201S | 11.5 | 10.3 | 11.3 | 8.2 | 9.2 | 17-85P | 28.1 | 23.2 | 29.0 | 29.0 | 25.3 |
| 10-5P | 15.8 | 12.6 | 13.5 | 14.1 | 12.8 | 17-85S | 31.0 | 26.2 | 30.6 | 30.6 | 26.4 |
| 10-5S | 17.1 | 13.9 | 14.8 | 15.4 | 14.1 | 21-12P | 35.0 | 31.4 | 34.4 | 26.4 | 31.4 |
| 10-26P | 14.2 | 11.0 | 11.9 | 12.5 | 8.7 | 21-12S | 39.6 | 36.0 | 39.0 | 31.0 | 36.0 |
| 10-26S | 15.3 | 12.1 | 12.5 | 16.7 | 9.2 | 21-22P | 37.3 | 33.7 | 36.7 | 28.7 | 33.7 |
| 10-200P | 15.0 | 11.8 | 12.7 | 13.3 | 10.0 | 21-22S | 43.6 | 40.0 | 43.0 | 35.0 | 40.0 |
| 10-200S | 16.3 | 13.1 | 14.0 | 14.6 | 11.3 | 21-130P | 32.9 | 29.3 | 32.3 | 24.3 | 29.3 |
| 10-201P | 15.3 | 12.1 | 13.3 | 13.6 | 10.3 | 21-130S | 39.4 | 35.8 | 38.8 | 30.8 | 35.8 |

2M801

F

2M801 Dual-Start ACME Threads Plug

2M801-007 and 2M801-008



2M801-007-16
2M801-007-26

2M801-008-16
2M801-008-26

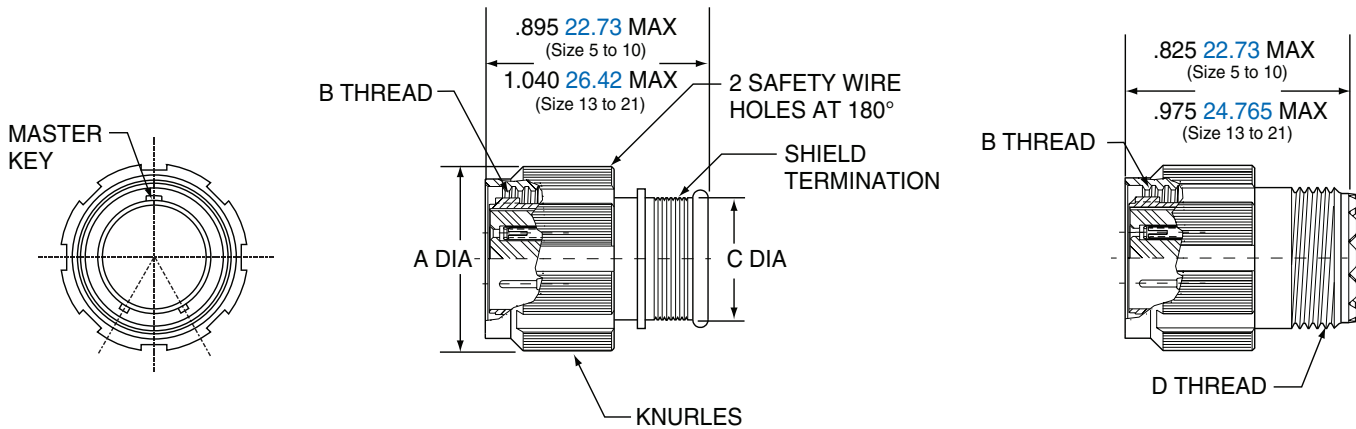

| Shell Size | Style 16 | | Style 26 | | B Thread | C Dia. | | D Thread UNEF-2A |
|------------|----------|-------|----------|-------|-------------------|--------|-------|------------------|
| | A Dia. | | A Dia. | | | in. | mm. | |
| | in. | mm. | in. | mm. | | | | |
| 5 | .545 | 13.84 | .660 | 16.76 | .3125-.05P-.1L-2B | .245 | 6.22 | .2500-32 |
| 6 | .610 | 15.49 | .710 | 18.03 | .3750-.05P-.1L-2B | .290 | 7.37 | .3125-32 |
| 7 | .695 | 17.65 | .790 | 20.07 | .4375-.05P-.1L-2B | .390 | 9.91 | .4375-28 |
| 8 | .750 | 19.05 | .860 | 21.84 | .5000-.05P-.1L-2B | .445 | 11.30 | .5000-28 |
| 9 | .810 | 20.57 | .920 | 23.37 | .5625-.05P-.1L-2B | .500 | 12.70 | .5625-24 |
| 10 | .890 | 22.61 | .985 | 25.02 | .6250-.05P-.1L-2B | .560 | 14.22 | .6250-24 |
| 13 | 1.060 | 26.92 | 1.150 | 29.21 | .8125-.1P-.2L-2B | .650 | 16.51 | .6875-24 |
| 16 | 1.250 | 31.75 | 1.345 | 34.16 | 1.0000-.1P-.2L-2B | .805 | 20.45 | .9375-20 |
| 17 | 1.310 | 33.27 | 1.400 | 35.56 | 1.0625-.1P-.2L-2B | .850 | 21.59 | .9375-20 |
| 21 | 1.560 | 39.62 | 1.660 | 42.16 | 1.3125-.1P-.2L-2B | 1.135 | 28.83 | 1.1875-18 |

2M801

F

2M801 Dual-Start ACME Threads Jam Nut

2M801-009-07 and 2M801-010-07

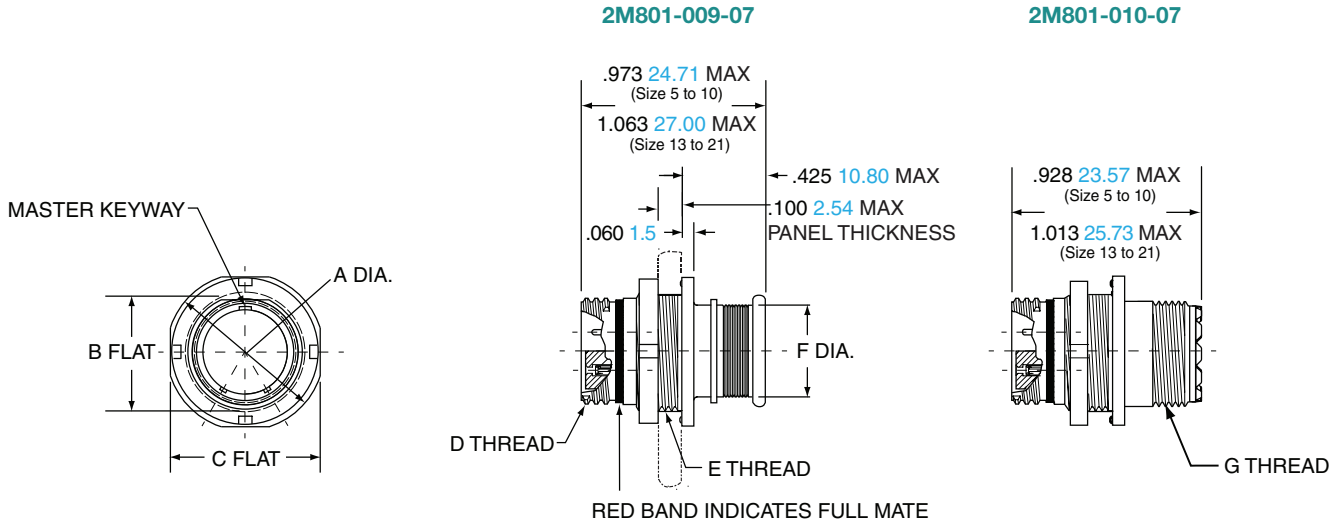

| Shell Size | A Dia. | | B Flat | | C Flat | | D Thread | E Thread | F Dia. | | G Thread UNEF-2A |
|------------|--------|-------|--------|-------|--------|-------|-------------------|------------------|--------|-------|------------------|
| | in. | mm. | in. | mm. | in. | mm. | | | in. | mm. | |
| 5 | .575 | 14.61 | .350 | 8.89 | .545 | 13.84 | .3125-.05P-.1L-2A | .3750-28 UN-2A | .245 | 6.22 | .2500-32 |
| 6 | .635 | 16.13 | .410 | 10.41 | .595 | 15.11 | .3750-.05P-.1L-2A | .4375-28 UNEF-2A | .290 | 7.37 | .3125-32 |
| 7 | .755 | 19.18 | .536 | 13.61 | .723 | 18.36 | .4375-.05P-.1L-2A | .5625-32 UN-2A | .390 | 9.91 | .4375-28 |
| 8 | .755 | 19.18 | .536 | 13.61 | .723 | 18.36 | .5000-.05P-.1L-2A | .5625-32 UN-2A | .445 | 11.30 | .5000-28 |
| 9 | .830 | 21.08 | .596 | 15.14 | .790 | 20.07 | .5625-.05P-.1L-2A | .6250-28 UN-2A | .500 | 12.70 | .5625-24 |
| 10 | .890 | 22.61 | .658 | 16.71 | .855 | 21.72 | .6250-.05P-.1L-2A | .6875-28 UN-2A | .560 | 14.22 | .6250-24 |
| 13 | 1.078 | 27.38 | .845 | 21.46 | 1.044 | 26.52 | .8125-.1P-.2L-2A | .8750-28 UN-2A | .650 | 16.51 | .6875-24 |
| 16 | 1.264 | 32.11 | 1.022 | 25.96 | 1.230 | 31.24 | 1.0000-.1P-.2L-2A | 1.0625-20 UN-2A | .805 | 20.45 | .9375-20 |
| 17 | 1.325 | 33.66 | 1.096 | 27.84 | 1.290 | 32.77 | 1.0625-.1P-.2L-2A | 1.125-28 UN-2A | .850 | 21.59 | .9375-20 |
| 21 | 1.625 | 41.28 | 1.347 | 34.16 | 1.577 | 40.06 | 1.3125-.1P-.2L-2A | 1.375-28 UN-2A | 1.135 | 28.83 | 1.1875-18 |

| JAM NUT PANEL CUTOUT | | | | |
|----------------------|---------------|---------------|---------------|---------------|
| Shell Size | A Flat | | B Dia. | |
| | in. ± .002 | mm. ± 0.05 | in. ± .002 | mm. ± 0.05 |
| 5 | .356 | 9.04 | .385 | 9.78 |
| 6 | .416 | 10.57 | .447 | 11.35 |
| 7 | .542 | 13.77 | .572 | 14.53 |
| 8 | .542 | 13.77 | .572 | 14.53 |
| 9 | .602 | 15.29 | .635 | 16.13 |
| 10 | .666 | 16.62 | .697 | 17.70 |
| 13 | .851 | 21.62 | .885 | 22.48 |
| 16 | 1.028 | 26.11 | 1.075 | 27.31 |
| 17 | 1.102 | 27.99 | 1.135 | 28.83 |
| 21 | 1.354 | 34.39 | 1.385 | 35.18 |

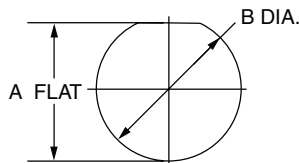

2M801 Dual-Start ACME Threads Square Flange Receptacle 2M801-009-02 and 2M801-010-02

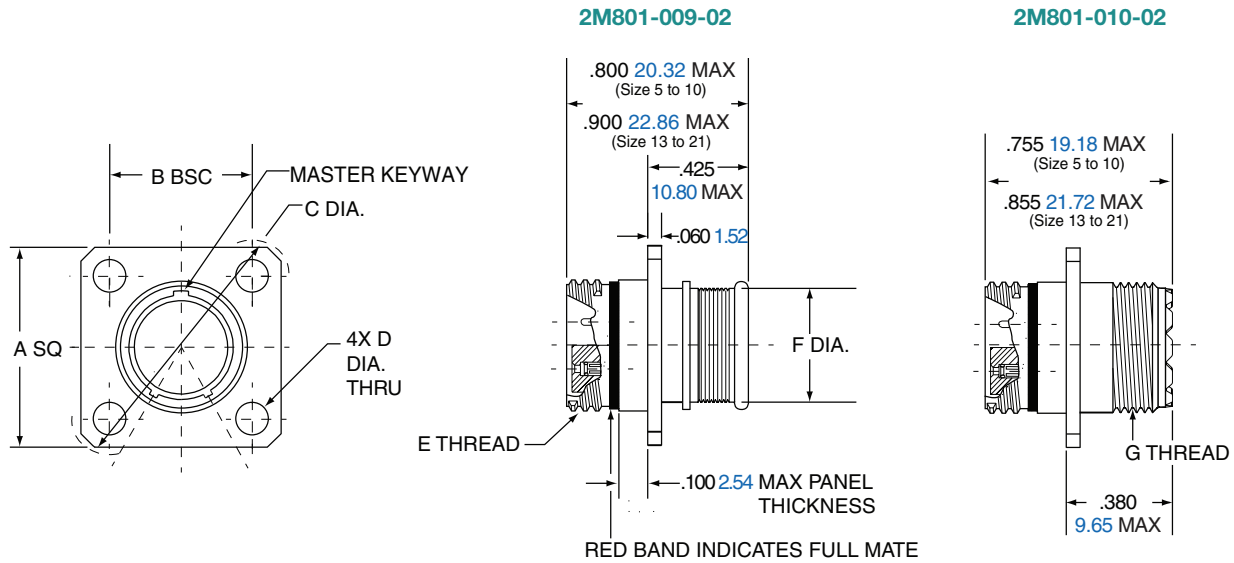

| Shell Size | A | | B BSC | | C Dia. | | D Dia. | | E Thread | F Dia. | | G Thread UNEF-2A |
|------------|-------|-------|-------|-------|--------|-------|------------|-----------|-------------------|--------|-------|------------------|
| | in. | mm. | in. | mm. | in. | mm. | in. ± .003 | mm. ± .08 | | in. | mm. | |
| 5 | .530 | 13.46 | .363 | 9.22 | .680 | 17.27 | .093 | 2.36 | .3125-.05P-.1L-2A | .245 | 6.22 | .2500-32 |
| 6 | .590 | 14.99 | .423 | 10.74 | .750 | 19.05 | .093 | 2.36 | .3750-.05P-.1L-2A | .290 | 7.37 | .3125-32 |
| 7 | .650 | 16.51 | .483 | 12.27 | .850 | 21.59 | .093 | 2.36 | .4375-.05P-.1L-2A | .390 | 9.91 | .4375-28 |
| 8 | .712 | 18.08 | .545 | 13.84 | .940 | 23.88 | .093 | 2.36 | .5000-.05P-.1L-2A | .445 | 11.30 | .5000-28 |
| 9 | .850 | 21.59 | .607 | 15.42 | 1.125 | 28.58 | .128 | 3.25 | .5625-.05P-.1L-2A | .500 | 12.70 | .5625-24 |
| 10 | .890 | 22.61 | .670 | 17.02 | 1.190 | 30.23 | .128 | 3.25 | .6250-.05P-.1L-2A | .560 | 14.22 | .6250-24 |
| 13 | 1.030 | 26.16 | .812 | 20.62 | 1.375 | 34.93 | .128 | 3.25 | .8125-.1P-.2L-2A | .650 | 16.51 | .6875-24 |
| 16 | 1.219 | 30.96 | .981 | 24.92 | 1.625 | 41.28 | .128 | 3.25 | 1.0000-.1P-.2L-2A | .805 | 20.45 | .9375-20 |
| 17 | 1.280 | 32.51 | 1.060 | 26.92 | 1.700 | 43.18 | .128 | 3.25 | 1.0625-.1P-.2L-2A | .850 | 21.59 | .9375-20 |
| 21 | 1.430 | 36.32 | 1.205 | 30.61 | 1.940 | 49.28 | .128 | 3.25 | 1.3125-.1P-.2L-2A | 1.135 | 28.83 | 1.1875-18 |

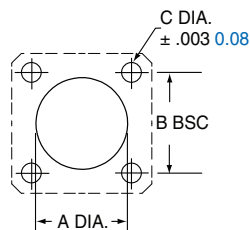

PANEL CUTOUT

| Shell Size | A Dia. | | B Dia. | | C Dia. | |
|------------|--------|-------|--------|-------|--------|------|
| | in. | mm. | in. | mm. | in. | mm. |
| 5 | .330 | 8.38 | .363 | 9.22 | .093 | 2.36 |
| 6 | .390 | 9.91 | .423 | 10.74 | .093 | 2.36 |
| 7 | .450 | 11.43 | .483 | 12.27 | .093 | 2.36 |
| 8 | .510 | 12.95 | .545 | 13.84 | .093 | 2.36 |
| 9 | .575 | 14.61 | .607 | 15.42 | .128 | 3.25 |
| 10 | .640 | 16.26 | .670 | 17.02 | .128 | 3.25 |
| 13 | .825 | 20.96 | .812 | 20.65 | .128 | 3.25 |
| 16 | 1.015 | 25.78 | .981 | 24.92 | .128 | 3.25 |
| 17 | 1.075 | 27.31 | 1.060 | 26.92 | .128 | 3.25 |
| 21 | 1.325 | 33.66 | 1.205 | 30.61 | .128 | 3.25 |

2M801 Dual-Start ACME Threads In-Line

2M801-009-01 and 2M801-010-01

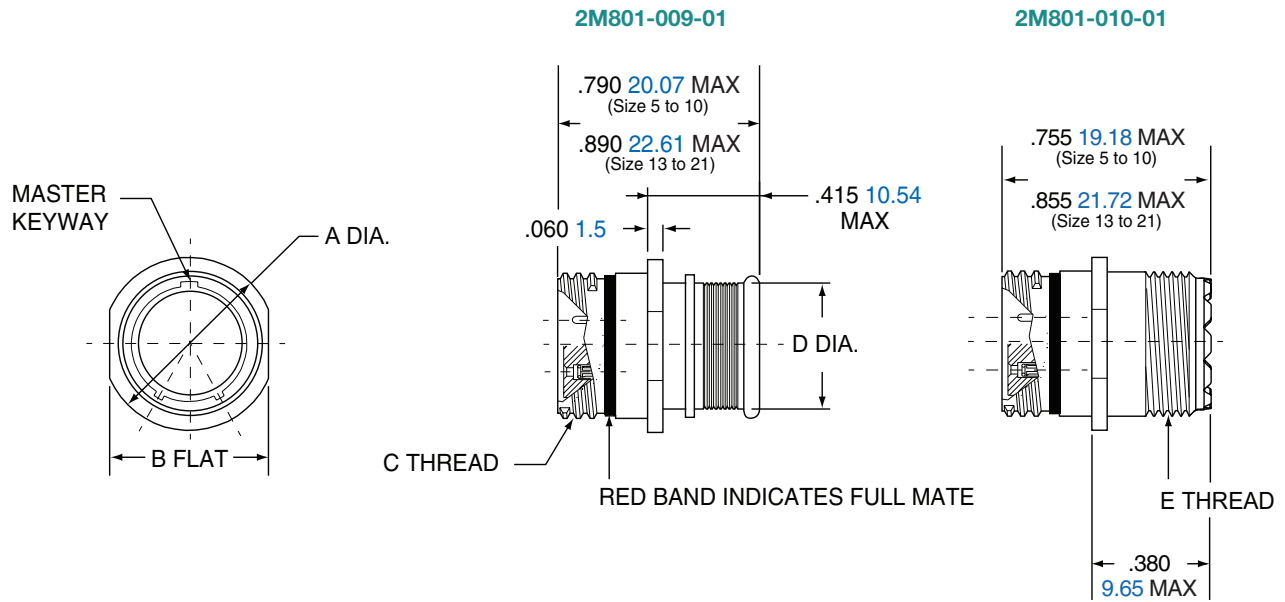

| Shell Size | A Dia. | | B Flat | | C Thread | D Dia. | | E Thread UNEF-2A |
|------------|--------|-------|--------|-------|-------------------|--------|-------|---------------------|
| | in. | mm. | in. | mm. | | in. | mm. | |
| 5 | .355 | 9.02 | .325 | 8.13 | .3125-.05P-.1L-2A | .245 | 6.22 | .2500-32 |
| 6 | .415 | 10.54 | .385 | 9.78 | .3750-.05P-.1L-2A | .290 | 7.37 | .3125-32 |
| 7 | .480 | 12.19 | .445 | 11.30 | .4375-.05P-.1L-2A | .390 | 9.91 | .4375-28 |
| 8 | .540 | 13.72 | .510 | 12.95 | .5000-.05P-.1L-2A | .445 | 11.30 | .5000-28 |
| 9 | .605 | 15.37 | .575 | 14.61 | .5625-.05P-.1L-2A | .500 | 12.70 | .5625-24 |
| 10 | .665 | 16.89 | .635 | 16.13 | .6250-.05P-.1L-2A | .560 | 14.22 | .6250-24 |
| 13 | .855 | 21.72 | .825 | 20.96 | .8125-.1P-.2L-2A | .650 | 16.51 | .6875-24 |
| 16 | 1.040 | 26.42 | 1.010 | 25.65 | 1.0000-.1P-.2L-2A | .805 | 20.44 | .9375-20 |
| 17 | 1.110 | 28.19 | 1.070 | 27.18 | 1.0625-.1P-.2L-2A | .850 | 21.59 | .9375-20 |
| 21 | 1.405 | 35.69 | 1.385 | 35.18 | 1.3125-.1P-.2L-2A | 1.135 | 28.83 | 1.1875-18 |

2M801 Dual-Start ACME Threads

Jam Nut and Square Flange 2M801-011 and 2M801-033



2M801-011-07
2M801-033-07

2M801-011-02
2M801-033-02

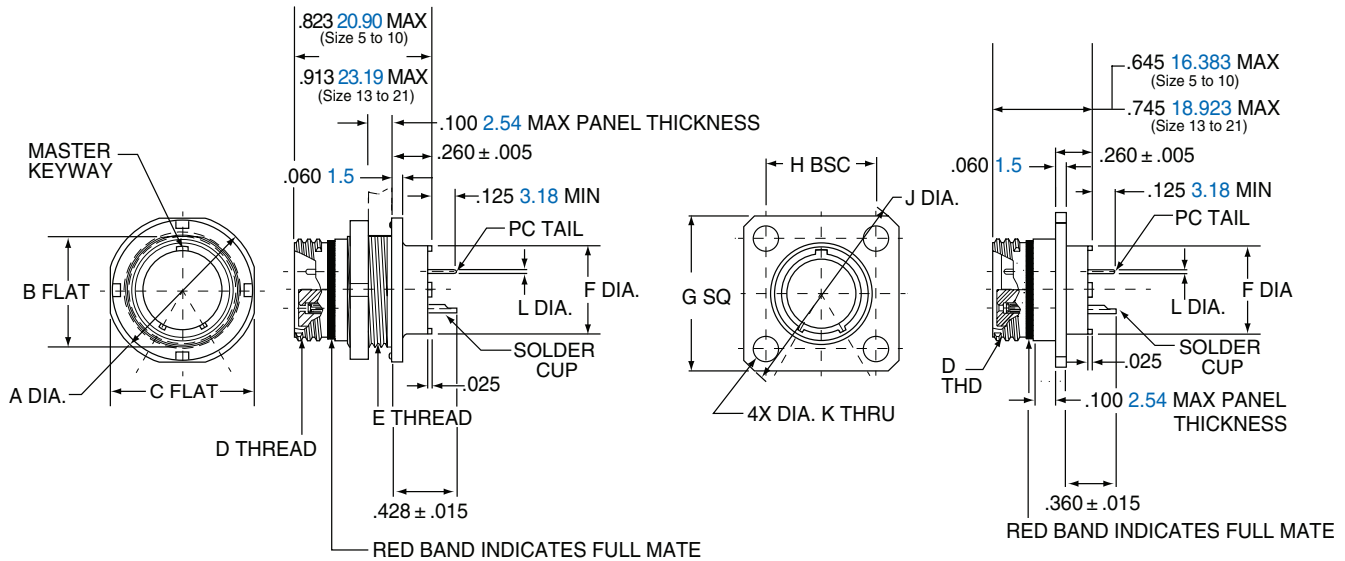

| Shell Size | A Dia. | | B Flat | | C Flat | | D Thread | E Thread | F Dia. | | G Sq. | | H BSC | | J Dia. | |
|------------|--------|-------|--------|-------|--------|-------|-------------------|-----------|--------|-------|-------|-------|-------|-------|--------|-------|
| | in. | mm. | in. | mm. | in. | mm. | | | in. | mm. | in. | mm. | in. | mm. | in. | mm. |
| 5 | .575 | 14.61 | .350 | 8.89 | .545 | 13.84 | .3125-.05P-.1L-2A | .3750-28 | .244 | 6.20 | .530 | 13.46 | .363 | 9.22 | .680 | 17.27 |
| 6 | .635 | 16.13 | .410 | 10.41 | .595 | 15.11 | .3750-.05P-.1L-2A | .4375-28 | .330 | 8.38 | .590 | 14.99 | .423 | 10.74 | .750 | 19.05 |
| 7 | .755 | 19.18 | .536 | 13.61 | .723 | 18.36 | .4375-.05P-.1L-2A | .5625-32 | .432 | 10.97 | .650 | 16.51 | .483 | 12.27 | .850 | 21.59 |
| 8 | .755 | 19.18 | .536 | 13.61 | .723 | 18.36 | .5000-.05P-.1L-2A | .5625-32 | .493 | 12.52 | .712 | 18.08 | .545 | 13.84 | .938 | 23.88 |
| 9 | .830 | 21.08 | .596 | 15.14 | .790 | 20.07 | .5625-.05P-.1L-2A | .6250-28 | .551 | 14.00 | .850 | 21.56 | .607 | 15.42 | 1.125 | 28.58 |
| 10 | .890 | 22.61 | .658 | 16.71 | .855 | 21.72 | .6250-.05P-.1L-2A | .6875-28 | .620 | 15.75 | .890 | 22.61 | .670 | 17.02 | 1.188 | 30.23 |
| 13 | 1.078 | 27.38 | .845 | 21.46 | 1.044 | 26.52 | .8125-.1P-.2L-2A | .8750-28 | .703 | 17.86 | 1.030 | 26.16 | .812 | 20.62 | 1.375 | 34.93 |
| 16 | 1.264 | 32.11 | 1.022 | 25.96 | 1.230 | 31.24 | 1.0000-.1P-.2L-2A | 1.0625-20 | .863 | 21.92 | 1.219 | 30.96 | .981 | 24.92 | 1.625 | 41.28 |
| 17 | 1.325 | 33.66 | 1.096 | 27.84 | 1.290 | 32.77 | 1.0625-.1P-.2L-2A | 1.1250-28 | .912 | 23.16 | 1.280 | 32.51 | 1.060 | 26.92 | 1.700 | 43.18 |
| 21 | 1.625 | 41.28 | 1.345 | 34.16 | 1.577 | 40.06 | 1.3125-.1P-.2L-2A | 1.3750-28 | 1.170 | 29.72 | 1.565 | 36.32 | 1.322 | 33.58 | 2.100 | 49.28 |

| Shell Size | K Dia. | | L Dia. Tail Dia. |
|------------|--------|------|-----------------------|
| | in. | mm. | |
| 5 | .093 | 2.36 | #23 .018/.022 |
| 6 | .093 | 2.36 | 0.46/0.56 |
| 7 | .093 | 2.36 | #20/20HD .025/.027 |
| 8 | .093 | 2.36 | 0.64/0.69 |
| 9 | .128 | 3.25 | #16 .060/.064 |
| 10 | .128 | 3.25 | 1.52/1.63 |
| 13 | .128 | 3.25 | #12 .092/.096 |
| 16 | .128 | 3.25 | 2.34/2.44 |
| 17 | .128 | 3.25 | |
| 21 | .128 | 3.25 | |

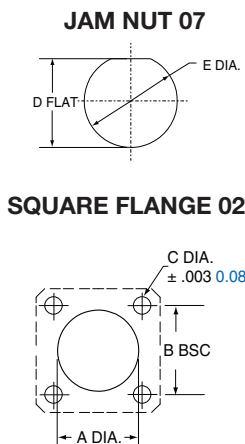

| Shell Size | PANEL CUTOUT | | | | | | | | | |
|------------|--------------|-------|--------|-------|--------|------|--------|-------|--------|-------|
| | A Dia. | | B Dia. | | C Dia. | | D Flat | | E Dia. | |
| | in. | mm. | in. | mm. | in. | mm. | in. | mm. | in. | mm. |
| 5 | .330 | 8.38 | .363 | 9.22 | .093 | 2.36 | .356 | 9.04 | .385 | 9.78 |
| 6 | .390 | 9.91 | .423 | 10.74 | .093 | 2.36 | .416 | 10.57 | .447 | 11.35 |
| 7 | .450 | 11.43 | .483 | 12.27 | .093 | 2.36 | .542 | 13.77 | .572 | 14.53 |
| 8 | .510 | 12.95 | .545 | 13.84 | .093 | 2.36 | .542 | 13.77 | .572 | 14.53 |
| 9 | .575 | 14.61 | .607 | 15.42 | .128 | 3.25 | .602 | 15.29 | .635 | 16.13 |
| 10 | .640 | 16.26 | .670 | 17.02 | .128 | 3.25 | .666 | 16.92 | .697 | 17.70 |
| 13 | .825 | 20.96 | .812 | 20.65 | .128 | 3.25 | .851 | 21.62 | .885 | 22.48 |
| 16 | 1.015 | 25.78 | .981 | 24.92 | .128 | 3.25 | 1.028 | 26.11 | 1.075 | 27.31 |
| 17 | 1.075 | 27.31 | 1.060 | 26.92 | .128 | 3.25 | 1.102 | 27.99 | 1.135 | 28.83 |
| 21 | 1.330 | 33.78 | 1.322 | 33.58 | .128 | 3.25 | 1.354 | 34.39 | 1.385 | 35.18 |

2M801 Dual-Start Right Angle PCB Jam Nut Connector 2M801-023-07

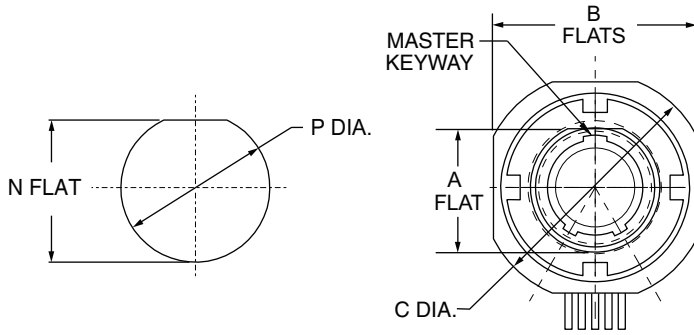

MASTER KEYWAY IS LOCATED AT TOP DEAD CENTER FOR ALL ARRANGEMENTS EXCEPT FOR THE 8-13.

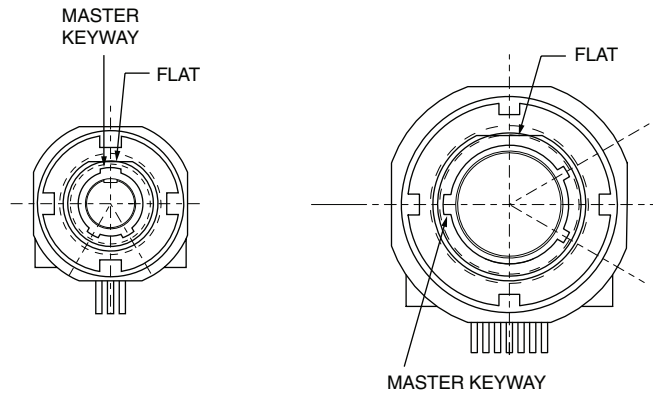
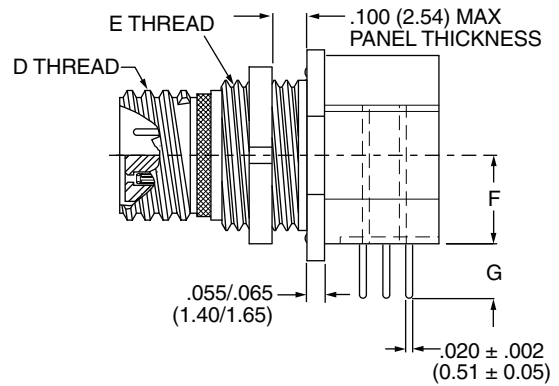

5-3, 6-4, 6-7, 7-10, AND 9-19
MASTER KEYWAY LOCATION

8-13
MASTER KEYWAY LOCATION

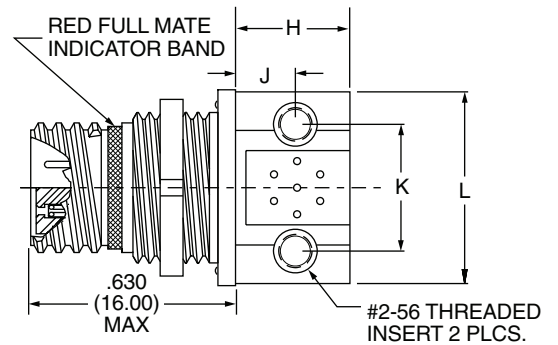

2M801

| Shell Size | A | | B | | C Dia. | | D Thread | E Thread | F | | G | | H | |
|------------|-----------|-----------|------|-------|--------|-------|-------------------|------------------|------|------|-----------|-----------|------|-------|
| | in. ±.005 | mm. ±0.13 | in. | mm. | in. | mm. | | | in. | mm. | in. ±.035 | mm. ±0.89 | in. | mm. |
| 5-3 | .350 | 8.89 | .548 | 13.92 | .575 | 14.61 | .3125-.05P-.1L-2A | .3750-28 UN-2A | .225 | 5.72 | .275 | 6.99 | .260 | 6.60 |
| 6-4 | .410 | 10.41 | .598 | 15.19 | .635 | 16.13 | .3750-.05P-.1L-2A | .4375-28 UNEF-2A | .225 | 5.72 | .265 | 6.73 | .345 | 8.76 |
| 6-7 | .410 | 10.41 | .598 | 15.19 | .635 | 16.13 | .3750-.05P-.1L-2A | .4375-28 UNEF-2A | .225 | 5.72 | .265 | 6.73 | .345 | 8.76 |
| 7-10 | .536 | 13.61 | .726 | 18.44 | .755 | 19.18 | .4375-.05P-.1L-2A | .5625-32 UN-2A | .296 | 7.52 | .273 | 6.93 | .345 | 8.76 |
| 8-2 | .538 | 13.67 | .728 | 18.49 | .758 | 19.25 | .5000-.05P-.1L-2A | .5625-32 UN-2A | .319 | 8.10 | .316 | .803 | .490 | 12.45 |
| 8-13 | .538 | 13.67 | .728 | 18.49 | .758 | 19.25 | .5000-.05P-.1L-2A | .5625-32 UN-2A | .319 | 8.10 | .316 | 8.03 | .490 | 12.45 |
| 9-19 | .596 | 15.14 | .793 | 20.14 | .833 | 21.16 | .5625-.05P-.1L-2A | .6250-28 UN-2A | .360 | 9.14 | .275 | 6.99 | .490 | 12.45 |

| Shell Size | J | | K | | L | | N | | P | |
|------------|------|------|------|-------|------|-------|-----------|-----------|-----------|-----------|
| | in. | mm. | in. | mm. | in. | mm. | in. ±.002 | mm. ±0.05 | in. ±.005 | mm. ±0.13 |
| 5-3 | .165 | 4.19 | .310 | 7.87 | .490 | 14.45 | .357 | 9.07 | .385 | 9.78 |
| 6-4 | .187 | 4.75 | .408 | 10.36 | .589 | 15.19 | .418 | 10.62 | .448 | 11.37 |
| 6-7 | .187 | 4.75 | .408 | 10.36 | .589 | 15.19 | .418 | 10.62 | .448 | 11.37 |
| 7-10 | .170 | 4.32 | .452 | 11.48 | .710 | 18.03 | .544 | 13.82 | .573 | 14.55 |
| 8-2 | .230 | 5.84 | .490 | 4.31 | .710 | 18.03 | .544 | 13.82 | .573 | 14.55 |
| 8-13 | .230 | 5.84 | .490 | 12.45 | .710 | 18.03 | .544 | 13.82 | .573 | 14.55 |
| 9-19 | .342 | 8.69 | .600 | 15.24 | .800 | 20.32 | .603 | 15.32 | .635 | 16.13 |

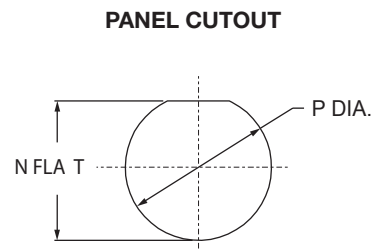

F

2M801 Dual-Start PCB Jam Nut, Double Flange Receptacle 2M801-075

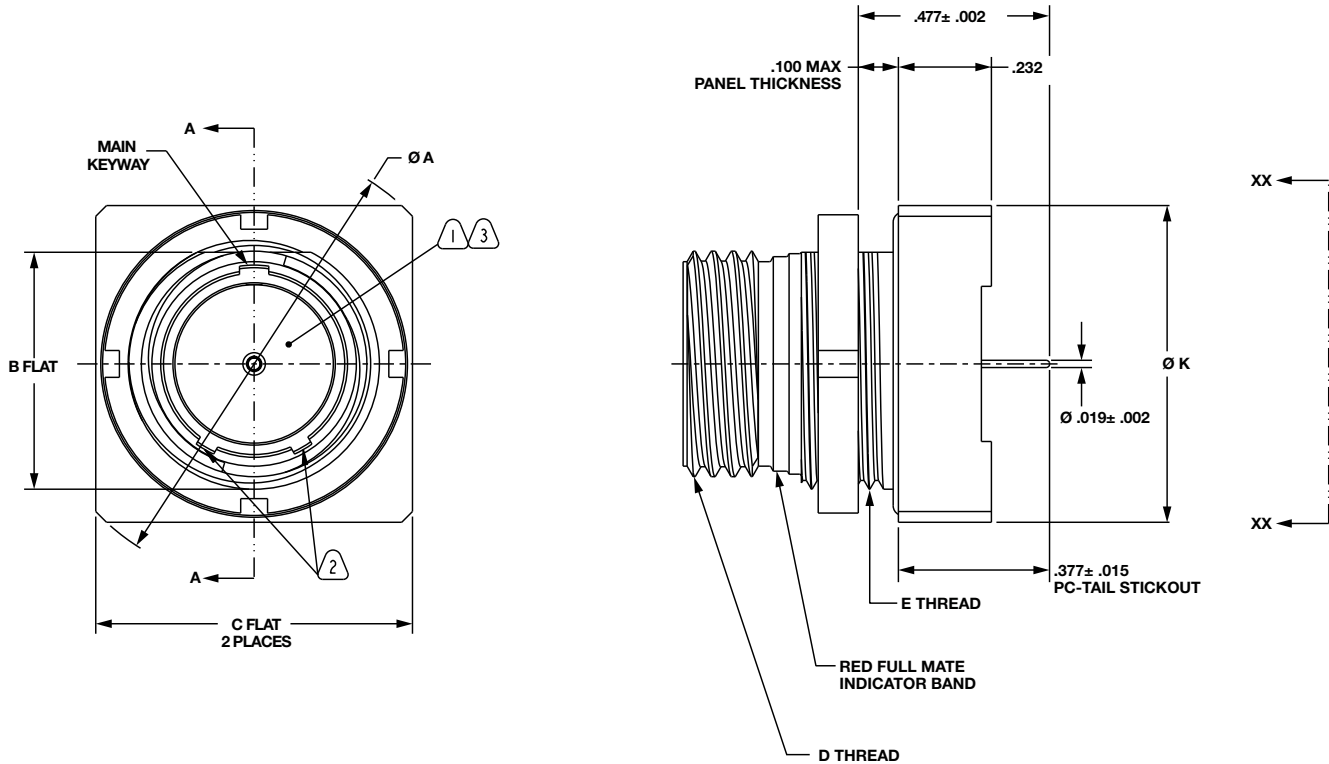

| Shell Size | A Dia. | | B Flat | | C Flat | | D Thread | E Thread | K Dia. | |
|------------|--------|-------|--------|-------|--------|-------|-------------------|-----------|--------|-------|
| | in. | mm. | in. | mm. | in. | mm. | | | in. | mm. |
| 5 | .575 | 14.61 | .350 | 8.89 | .545 | 13.84 | .3125-.05P-.1L-2A | .3750-28 | .844 | 21.43 |
| 6 | .635 | 16.13 | .410 | 10.41 | .595 | 15.11 | .3750-.05P-.1L-2A | .4375-28 | .900 | 22.86 |
| 7 | .755 | 19.18 | .536 | 13.61 | .723 | 18.36 | .4375-.05P-.1L-2A | .5625-32 | NA | NA |
| 8 | .755 | 19.18 | .536 | 13.61 | .723 | 18.36 | .5000-.05P-.1L-2A | .5625-32 | NA | NA |
| 9 | .830 | 21.08 | .596 | 15.14 | .790 | 20.07 | .5625-.05P-.1L-2A | .6250-28 | 1.000 | 25.4 |
| 10 | .890 | 22.61 | .658 | 16.71 | .855 | 21.72 | .6250-.05P-.1L-2A | .6875-28 | NA | NA |
| 13 | 1.078 | 27.38 | .845 | 21.46 | 1.044 | 26.52 | .8125-.1P-.2L-2A | .8750-28 | NA | NA |
| 16 | 1.264 | 32.11 | 1.022 | 25.96 | 1.230 | 31.24 | 1.0000-.1P-.2L-2A | 1.0625-20 | NA | NA |
| 17 | 1.325 | 33.66 | 1.096 | 27.84 | 1.290 | 32.77 | 1.0625-.1P-.2L-2A | 1.1250-28 | NA | NA |
| 21 | 1.625 | 41.28 | 1.345 | 34.16 | 1.577 | 40.06 | 1.3125-.1P-.2L-2A | 1.3750-28 | NA | NA |

2M801

F

2M801 Protection Caps

Ordering Guide for Metal Protection Cap 2M667-217 and 218

2M801 Double Start Protective Caps are available in plug and receptacle versions. Protective caps keep the connector interface dry and clean while not in use. Caps come in a variety of materials, lanyard styles and lengths to accommodate specific design requirements.

2M801 FEATURES INCLUDE:

- Aluminum or Stainless Steel Bodies
- Rubber Gaskets for Environmental Sealing
- Stainless Steel Fittings
- Variety of attachments



| 1. | 2. | 3. | 4. | 5. | 6. |
|-----------|---------------|-----------------|----------------------|-----------------|-----------------------------|
| SERIES | SERVICE CLASS | ATTACHMENT TYPE | CONNECTOR SHELL SIZE | ATTACHMENT CODE | ATTACHMENT LENGTH IN INCHES |
| 2M667-21X | -NF | -S | 5 | 04 | -5 |

| 1. SERIES | |
|-----------|--------------------------------------|
| Part # | Description |
| 2M667-217 | Protection Caps 2M801 Plugs |
| 2M667-218 | Protection Caps 2M801 Receptacles |

| 4. CONNECTOR SHELL SIZE | |
|-------------------------|--|
| Part # | |
| 5 | |
| 6 | |
| 7 | |
| 8 | |
| 9 | |
| 10 | |
| 13 | |
| 16 | |
| 17 | |
| 21 | |

| 2. SERVICE CLASS | | | |
|------------------|--------|---------------------------------|------|
| Material | Part # | Description | RoHS |
| ALUMINUM | -C | Black Anodized (Non-conductive) | |
| | -M | Electroless Nickel | |
| | -NF | Olive Drab Cadmium | |
| | -MT | Durmalon (Ni PTFE) | |
| | -ZN | Olive Drab Zinc Nickel | |
| | -ZNU | Black Zinc Nickel | |
| STAINLESS STEEL | -Z1 | Passivated | |
| | -ZL | Electrolytic Nickel | |

| 3. ATTACHMENT TYPE | | |
|--------------------|--------|--|
| | Part # | Description |
| | -G | Nylon Rope |
| | -H | Stainless Steel Wire Rope, Teflon® Jacket |
| | -N | No Attachment |
| | -S | Stainless Steel Sash Chain |
| | -SK | Nylon Rope With Slip Knot |
| | -T | Stainless Steel Wire Rope, No Jacket |
| | -U | Stainless Steel Wire Rope, Polyurethane Jacket |

| 5. ATTACHMENT CODE | | | |
|--|------------|-------------------------|----------------|
| Omit for attachment Types N (No Attachment) and SK (Slip Knot) | | | |
| | Small Ring | 01 - 126 (3.20) I.D. | |
| | | 02 - 145 (3.68) I.D. | |
| | | 04 - 188 (4.78) I.D. | |
| | | 06 - 197 (5.00) I.D. | |
| | | | For Shell Size |
| | Large Ring | 14 - 385 (9.78) I.D. | 5 |
| | | 15 - 445 (11.30) I.D. | 6 |
| | | 16 - 570 (14.48) I.D. | 7, 8 |
| | | 17 - 635 (16.13) I.D. | 9 |
| | | 18 - 695 (17.65) I.D. | 10 |
| | | 19 - 885 (22.48) I.D. | 13 |
| | | 20 - 1,070 (27.17) I.D. | 16 |
| | | 21 - 1,135 (28.83) I.D. | 17 |
| | Split Ring | 50 - 420 (10.67) I.D. | |
| | | 52 - 480 (12.19) I.D. | |
| | | 54 - 635 (16.13) I.D. | |
| | | 56 - 745 (18.92) I.D. | |
| | | 58 - 885 (22.48) I.D. | |
| | | 60 - 1,010 (25.65) I.D. | |
| | | 64 - 1,125 (28.58) I.D. | |
| 68 - 1,345 (34.16) I.D. | | | |

| 5. ADDITIONAL ATTACHMENT CODE | |
|-------------------------------|-------------------------|
| | Large Ring |
| | 22 - 1,210 (30.73) I.D. |
| | 25 - 1,530 (38.86) I.D. |
| | 23 - 1,275 (32.39) I.D. |

| 6. ATTACHMENT LENGTH IN INCHES | |
|--|-------------|
| -5 | Inch Length |
| Omit for attachment Type N (No Attachment) Example "-5" equals five inch length | |

Assembly Instructions for Protection Cap, see page 100.

2M801 Dual-Start ACME Threads

Metal Protective Cap 2M667-217



2M667-217 (PLUG)

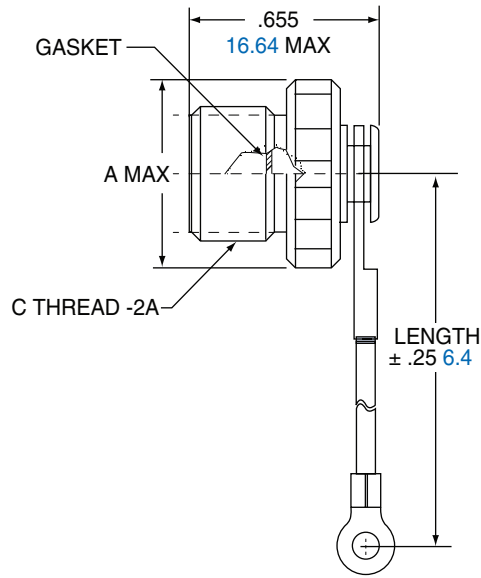

| Shell Size | A Max. | | B Max. | | C |
|------------|--------|-------|--------|-------|----------------|
| | in. | mm. | in. | mm. | |
| 5 | .463 | 11.76 | .550 | 13.97 | .3125-.05P-1L |
| 6 | .523 | 13.28 | .613 | 15.57 | .3750-.05P-1L |
| 7 | .588 | 14.94 | .700 | 17.78 | .4375-.05P-1L |
| 8 | .648 | 16.46 | .758 | 19.25 | .5000-.05-.1L |
| 9 | .713 | 18.11 | .813 | 20.65 | .5625-.05P-.1L |
| 10 | .773 | 19.63 | .893 | 22.68 | .6250-.05P-1L |
| 13 | .963 | 24.46 | 1.063 | 27.00 | .8125-.1P-.2L |
| 16 | 1.148 | 29.16 | 1.257 | 31.93 | 1.0000-.1P-.2L |
| 17 | 1.213 | 30.81 | 1.313 | 33.35 | 1.0625-.1P-.2L |
| 21 | 1.473 | 37.41 | 1.563 | 39.70 | 1.3125-.1P-.2L |

| MATERIALS | |
|----------------|-----------------------------------|
| Cover | Aluminum alloy or stainless steel |
| Gasket | Silicone rubber |
| Wire, Hardware | Stainless steel, passivated |

2M801

F

2M801 Dual-Start ACME Threads

Metal Protective Cap 2M667-218

2M667-218 (RECEPTACLE)

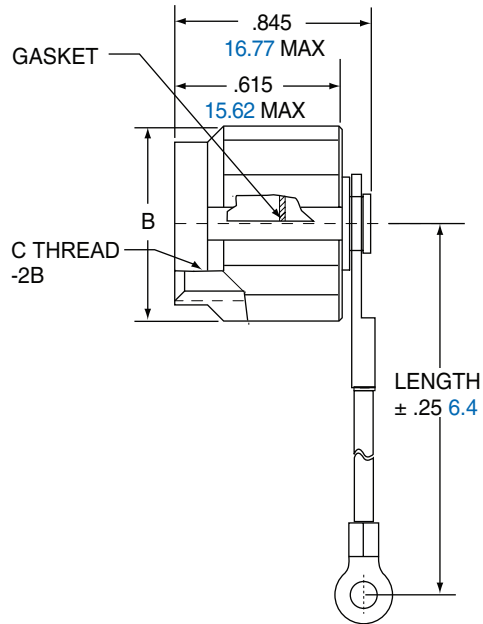

| Shell Size | A Max. | | B Max. | | C |
|------------|--------|-------|--------|-------|----------------|
| | in. | mm. | in. | mm. | |
| 5 | .463 | 11.76 | .550 | 13.97 | .3125-.05P-1L |
| 6 | .523 | 13.28 | .613 | 15.57 | .3750-.05P-1L |
| 7 | .588 | 14.94 | .700 | 17.78 | .4375-.05P-1L |
| 8 | .648 | 16.46 | .758 | 19.25 | .5000-.05-.1L |
| 9 | .713 | 18.11 | .813 | 20.65 | .5625-.05P-.1L |
| 10 | .773 | 19.63 | .893 | 22.68 | .6250-.05P-1L |
| 13 | .963 | 24.46 | 1.063 | 27.00 | .8125-.1P-.2L |
| 16 | 1.148 | 29.16 | 1.257 | 31.93 | 1.0000-.1P-.2L |
| 17 | 1.213 | 30.81 | 1.313 | 33.35 | 1.0625-.1P-.2L |
| 21 | 1.473 | 37.41 | 1.563 | 39.70 | 1.3125-.1P-.2L |

MATERIALS

| | |
|----------------|-----------------------------------|
| Cover | Aluminum alloy or stainless steel |
| Gasket | Silicone rubber |
| Wire, Hardware | Stainless steel, passivated |

Amphenol's 2M Micro38999 Connector Series... The New Aerospace Standard

Averaging less than half the size and weight of their 38999 ancestors, Amphenol's 2M Micro38999 series are an easy and inexpensive way to take weight out of your system. 2M meet or exceed most environmental and performance requirements listed in MIL-DTL-38999, so modernizing your equipment doesn't mean sacrificing ruggedness. With almost 2,000,000 configurations in every termination style and a full complement of accessories available right out of the catalog, customization has never been easier. Smarter, faster and smaller: Amphenol's 2M... the only connector you'll ever need.



Page Guide

| | |
|-----------------------|------|
| 2M805 | |
| Order | G-82 |
| Flange Mount..... | G-83 |
| Solder Mount..... | G-84 |
| Jam Nut..... | G-85 |
| 2M804 | |
| Order | G-86 |
| Rear Panel Jam | G-87 |
| Front Panel Jam..... | G-88 |
| 2M803 | |
| Order | G-89 |
| Flange Mt. / Jam | G-90 |
| 2M801 | |
| Order | G-91 |
| Jam Nut..... | G-92 |
| Square Flange | G-93 |
| Weld Mount | G-94 |

Why 2M Hermetic?

2M Series of Hermetic Receptacles provide superior sealing of 1×10^{-7} cc/second helium leak rate and are 100% tested prior to shipping. This superior sealing is accomplished through the use of glass insulator fused to stainless steel shells and nickel iron alloy contacts.



2M805 Tri-Start Hermetic Receptacle

Ordering Guide for 2M805-006

2M805 Series of Hermetic Receptacles provide superior sealing of 1x10⁻⁸ cc/second helium leak rate and are 100% tested prior to shipping. This superior sealing is accomplished through the use of glass insulator fused to stainless steel shells and iron alloy contacts.

2M805 FEATURES INCLUDE:

- Low profile shells for minimum box protrusion
- Shell Standoffs for PC Board washout
- Non-removable PC and/or Solder cup contacts
- Hermetic Sealing



| 1. SERIES | 2. SHELL SIZE | 3. SERVICE CLASS | 4. SHELL SIZE-INSERT AGGMT | 5. CONTACTS | 6. KEYING |
|-----------|---------------|------------------|----------------------------|-------------|-----------|
| 2M805-006 | -07 | Z1 | 12-26 | C | A |

Example Part Number

| 1. SERIES | |
|-----------|---------------------|
| Part # | Description |
| 2M805-006 | Hermetic Receptacle |

| 2. SHELL SIZE | |
|---------------|--|
| Part # | Description |
| -02 | Square Flange |
| -03 | Weld Mount (only available in Z1 Finish) |
| -07 | Jam Nut for Rear Panel Mounting Receptacle |

| 3. SERVICE CLASS | | | |
|------------------|--------|---------------------|------|
| Material | Part # | Description | RoHS |
| STAINLESS STEEL | Z1 | Passivated | |
| | ZL | Electrolytic Nickel | |

| 4. SHELL SIZE-INSERT ARRANGEMENT |
|----------------------------------|
| See Table on pages 7-20 |

| 5. CONTACTS | |
|-------------|---|
| Part # | Description |
| P | Pin- Solder Cup |
| C | Pin-PC Tail |
| H | Pin, Solder Cup- Without Interfacial Seal |
| Y | Pin, PC Tail- Without Interfacial Seal |

| 6. KEYING | | |
|-----------|------|------|
| Part # | A° | B° |
| A | 150° | 210° |
| B | 75° | 210° |
| C | 95° | 230° |
| D | 140° | 275° |

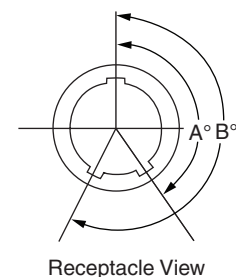

Note: Please contact the factory directly for a listing of tooled interfacial seals for the hermetically sealed connectors.

Please note, Amphenol standard 2M hermetic connector are provided less the interfacial seal. Please contact the factory for availability on the interfacial seal.

2M805 Tri-Start Flange Mount Hermetic

2M805-006-02



2M805-006-02

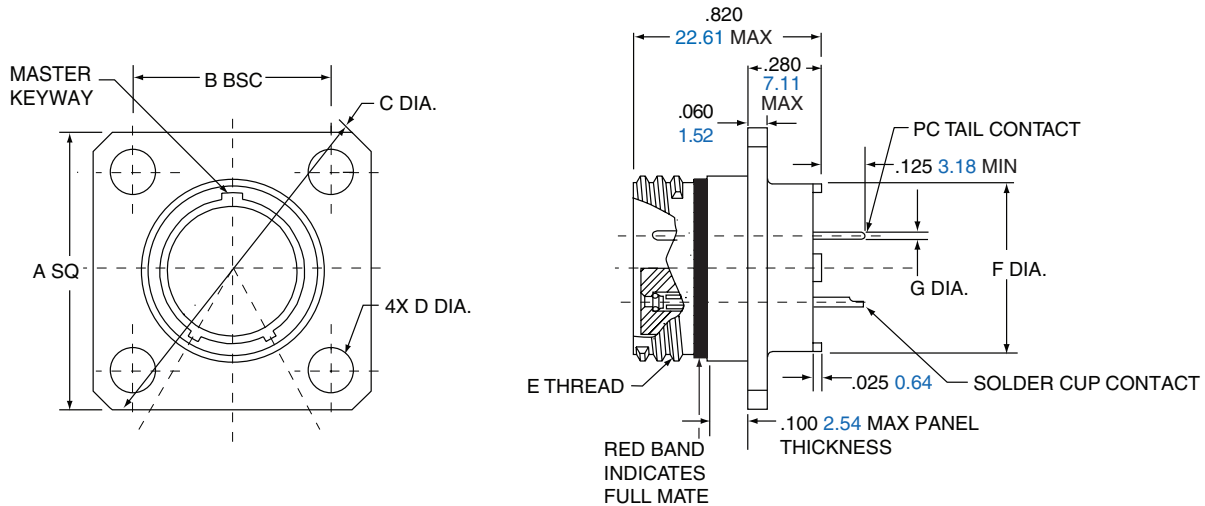

| Shell Size | A Sq. | | B BSC. | | C Dia. | | D Dia. | | E Threads | F Dia. | | G PC Tail Dia. |
|------------|-------|-------|--------|-------|--------|-------|-----------|----------|----------------------|--------|-------|------------------------------------|
| | in. | mm. | in. | mm. | in. | mm. | in. ±.003 | mm. ±.08 | | in. | mm. | |
| 8 | .853 | 21.67 | .660 | 16.76 | 1.153 | 29.29 | .091 | 2.31 | .5000-.1P-.3L-TS-2A | .330 | 8.38 | #23 .018/.022 0.46/0.56 |
| 9 | .916 | 23.27 | .723 | 18.36 | 1.233 | 31.32 | .091 | 2.31 | .5625-.1P-.3L-TS-2A | .432 | 10.97 | #20/20HD .024/.028 0.64/0.69 |
| 10 | .978 | 24.84 | .785 | 19.94 | 1.333 | 33.86 | .091 | 2.31 | .6250-.1P-.3L-TS-2A | .493 | 12.52 | #20/20HD .024/.028 0.64/0.69 |
| 11 | 1.042 | 26.47 | .848 | 21.54 | 1.413 | 35.89 | .091 | 2.31 | .6875-.1P-.3L-TS-2A | .551 | 14.00 | #16 .060/.064 1.521/1.63 |
| 12 | 1.102 | 27.99 | .909 | 23.09 | 1.503 | 38.18 | .091 | 2.31 | .7500-.1P-.3L-TS-2A | .622 | 15.80 | #16 .060/.064 1.521/1.63 |
| 15 | 1.291 | 32.79 | 1.058 | 26.87 | 1.753 | 44.53 | .125 | 3.18 | .9375-.1P-.3L-TS-2A | .703 | 17.86 | #12 .092/.096 2.34/2.44 |
| 18 | 1.478 | 37.54 | 1.255 | 31.88 | 2.003 | 50.88 | .125 | 3.18 | 1.1250-.1P-.3L-TS-2A | .863 | 21.92 | #12 .092/.096 2.34/2.44 |
| 19 | 1.540 | 39.12 | 1.327 | 33.71 | 2.097 | 53.26 | .125 | 3.18 | 1.1875-.1P-.3L-TS-2A | .912 | 23.16 | #12 .092/.096 2.34/2.44 |
| 23 | 1.790 | 45.47 | 1.570 | 39.88 | 2.443 | 62.05 | .125 | 3.18 | 1.4375-.1P-.3L-TS-2A | 1.163 | 29.54 | #12 .092/.096 2.34/2.44 |

Hermetic

G

2M805 Tri-Start Solder Mount Hermetic

2M805-006-03

2M805-006-03

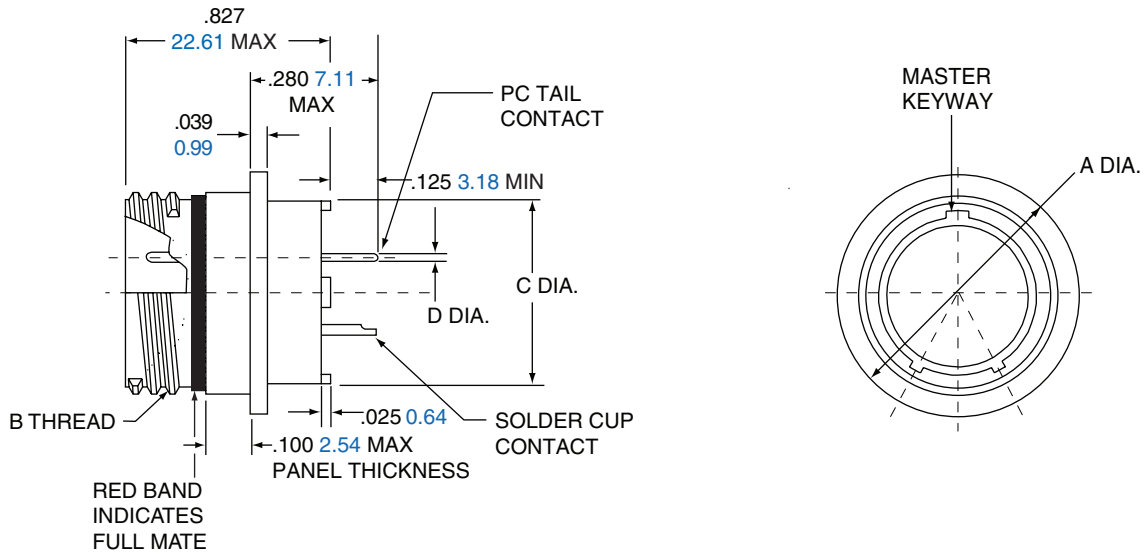

| Shell Size | A Dia. | | B Threads | C Dia. | | D PC Tail Dia. |
|------------|--------|-------|----------------------|--------|-------|---|
| | in. | mm. | | in. | mm. | |
| 8 | .625 | 15.88 | .5000-.1P-.3L-TS-2A | .330 | 8.38 | #23 .018/.022 0.46/0.56 |
| 9 | .688 | 17.48 | .5625-.1P-.3L-TS-2A | .432 | 10.97 | |
| 10 | .750 | 19.75 | .6250-.1P-.3L-TS-2A | .493 | 12.52 | #20/20HD .025/.027 0.64/0.69 |
| 11 | .812 | 20.62 | .6875-.1P-.3L-TS-2A | .551 | 14.00 | |
| 12 | .875 | 22.23 | .7500-.1P-.3L-TS-2A | .620 | 15.78 | |
| 15 | 1.062 | 26.97 | .9375-.1P-.3L-TS-2A | .703 | 17.86 | #16 .060/.064 1.521/1.63 |
| 18 | 1.250 | 31.75 | 1.1250-.1P-.3L-TS-2A | .863 | 21.92 | |
| 19 | 1.312 | 33.32 | 1.1875-.1P-.3L-TS-2A | .912 | 23.16 | #12 .092/.096 2.34/2.44 |
| 23 | 1.563 | 39.70 | 1.4375-.1P-.3L-TS-2A | 1.162 | 29.51 | |

Hermetic

2M805 Tri-Start Jam Nut Hermetic

2M805-006-07



2M805-006-07

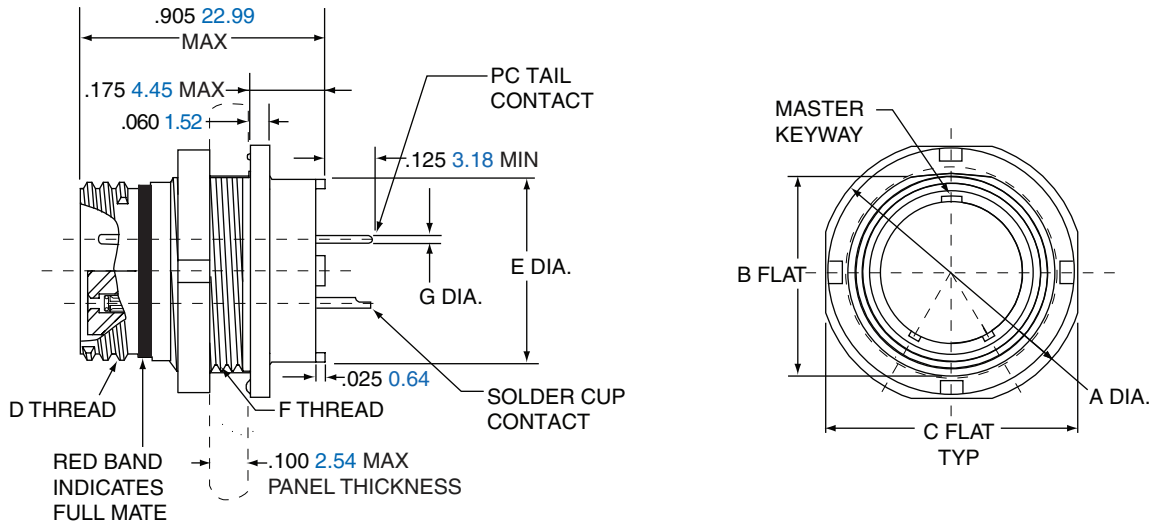

| Shell Size | A Dia. | | B Flat | | C Flat | | D Threads | E Dia. | | F Threads | G PC Tail Dia. |
|------------|--------|-------|--------|-------|--------|-------|----------------------|--------|-------|-----------------|------------------------------------|
| | in. | mm. | in. | mm. | in. | mm. | | in. | mm. | | |
| 8 | .760 | 19.30 | .535 | 13.59 | .730 | 18.54 | .5000-.1P-.3L-TS-2A | .330 | 8.38 | .5625-28 UN-2A | #23 .018/.022 0.46/0.56 |
| 9 | .880 | 22.35 | .661 | 16.79 | .850 | 21.59 | .5625-.1P-.3L-TS-2A | .432 | 10.97 | .6875-28 UN-2A | |
| 10 | .880 | 22.35 | .661 | 16.79 | .850 | 21.59 | .6250-.1P-.3L-TS-2A | .493 | 12.52 | .6875-28 UN-2A | #20/20HD .024/.028 0.64/0.69 |
| 11 | .955 | 24.26 | .721 | 18.31 | .925 | 23.50 | .6875-.1P-.3L-TS-2A | .551 | 14.00 | .7500-28 UN-2A | |
| 12 | 1.060 | 26.92 | .784 | 19.91 | 1.035 | 26.29 | .7500-.1P-.3L-TS-2A | .620 | 15.78 | .8125-28 UN-2A | |
| 15 | 1.203 | 30.56 | .970 | 24.64 | 1.173 | 29.79 | .9375-.1P-.3L-TS-2A | .703 | 17.86 | 1.0000-28 UN-2A | #16 .060/.064 1 .521/1.63 |
| 18 | 1.389 | 35.28 | 1.147 | 29.13 | 1.359 | 34.52 | 1.1250-.1P-.3L-TS-2A | .863 | 21.92 | 1.1875-28 UN-2A | |
| 19 | 1.450 | 36.83 | 1.221 | 31.01 | 1.420 | 36.07 | 1.1875-.1P-.3L-TS-2A | .912 | 23.16 | 1.2500-28 UN-2A | #12 .092/.096 2.34/2.44 |
| 23 | 1.705 | 43.31 | 1.470 | 37.34 | 1.675 | 42.55 | 1.4375-.1P-.3L-TS-2A | 1.162 | 29.51 | 1.5000-28 UN-2A | |

PANEL CUTOUT FOR JAM NUT

| Shell Size | A Flat | | B Dia | |
|------------|--------------|---------------|--------------|---------------|
| | in. ±.002 | mm. ± 0.05 | in. ±.005 | mm. ± 0.13 |
| 8 | .543 | 13.79 | .572 | 14.53 |
| 9 | .669 | 16.99 | .698 | 17.73 |
| 10 | .669 | 16.99 | .698 | 17.73 |
| 11 | .729 | 18.51 | .760 | 19.30 |
| 12 | .792 | 20.17 | .822 | 20.88 |
| 15 | .978 | 24.84 | 1.010 | 25.65 |
| 18 | 1.155 | 29.34 | 1.198 | 30.43 |
| 19 | 1.231 | 31.27 | 1.260 | 32.00 |
| 23 | 1.480 | 37.59 | 1.510 | 38.35 |

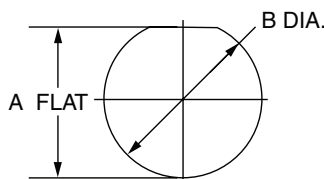

2M804 Push-Pull Hermetic Receptacle

Ordering Guide for 2M804-006

2M804 Series of Hermetic Receptacles provide superior sealing of 1×10^{-8} cc/second helium leak rate and are 100% tested prior to shipping. This superior sealing is accomplished through the use of glass insulator fused to stainless steel shells and iron alloy contacts.

2M804 FEATURES INCLUDE:

- Low profile shells for minimum box protrusion
- Shell Standoffs for PC Board washout
- Non-removable PC and/or Solder cup contacts
- Hermetic Sealing

| 1. | 2. | 3. | 4. | 5. | 6. |
|-----------|------------|---------------|-------------------------|----------|--------|
| SERIES | SHELL SIZE | SERVICE CLASS | SHELL SIZE-INSERT AGGMT | CONTACTS | KEYING |
| 2M804-006 | -07 | Z1 | 9-19 | P | A |

Example Part Number

| 1. SERIES | |
|-----------|---|
| Part # | Description |
| 2M804-006 | Hermetic Receptacle with Printed Circuit Board Contacts or Solder Cup Contacts. |

| 2. SHELL SIZE | |
|---------------|--|
| Part # | Description |
| -00 | Jam Nut for Front Panel Mounting |
| -07 | Jam Nut for Rear Panel Mounting Receptacle |

| 3. SERVICE CLASS | | | |
|------------------|--------|---------------------|------|
| Material | Part # | Description | RoHS |
| STAINLESS STEEL | Z1 | Passivated | |
| | ZL | Electrolytic Nickel | |

| 4. SHELL SIZE-INSERT ARRANGEMENT | |
|----------------------------------|--|
| See Table pg 7-20 | |

| 5. CONTACTS | |
|-------------|---|
| Part # | Description |
| P | Pin- Solder Cup |
| C | Pin-PC Tail |
| H | Pin, Solder Cup- Without Interfacial Seal |
| Y | Pin, PC Tail- Without Interfacial Seal |

| 6. KEYING | | |
|-----------|------|------|
| Part # | A° | B° |
| A | 150° | 210° |
| B | 75° | 210° |
| C | 95° | 230° |
| D | 140° | 275° |

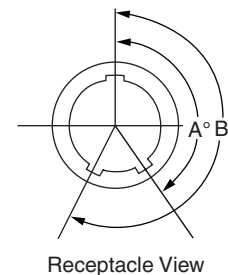

Note: Please contact the factory directly for a listing of tooled interfacial seals for the hermetically sealed connectors. Please note, Amphenol standard 2M hermetic connector are provided less the interfacial seal. Please contact the factory for availability on the interfacial seal.

2M804 Push-Pull Rear Panel Jam Nut Hermetic

2M804-006-07



2M804-006-07

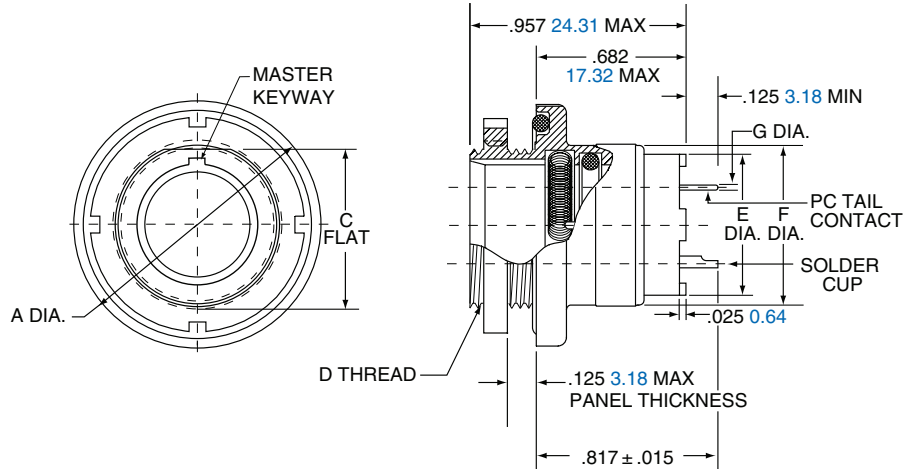

| Shell Size | A Dia. | | C Flat | | D Thread UN-2A | E Dia. | | F Dia. | | G PC Tail Dia. |
|------------|--------|-------|--------|-------|----------------|--------|-------|--------|-------|------------------------------------|
| | in. | mm. | in. | mm. | | in. | mm. | in. | mm. | |
| 5 | .773 | 19.63 | .414 | 10.52 | .4375-32 | .274 | 6.96 | .448 | 11.38 | #23 .018/.022 0.46/0.56 |
| 6 | .833 | 21.16 | .468 | 11.89 | .5000-32 | .329 | 8.36 | .513 | 13.03 | |
| 7 | .903 | 22.94 | .593 | 15.06 | .6250-28 | .431 | 10.95 | .573 | 14.55 | #20/20HD .025/.027 0.64/0.69 |
| 8 | .958 | 24.33 | .593 | 15.06 | .6250-28 | .493 | 12.52 | .596 | 15.14 | |
| 9 | .998 | 25.35 | .653 | 16.59 | .6875-28 | .551 | 14.00 | .691 | 17.55 | #16 .060/.064 1.52/1.63 |
| 10 | 1.083 | 27.51 | .721 | 18.31 | .7500-28 | .619 | 15.72 | .728 | 18.49 | |
| 12 | 1.183 | 30.05 | .843 | 21.41 | .8750-28 | .703 | 17.86 | .883 | 22.43 | #12 .092/.096 2.34/2.44 |
| 14 | 1.323 | 33.60 | .968 | 24.59 | 1.0000-28 | .863 | 21.92 | 1.003 | 25.48 | |
| 15 | 1.373 | 34.87 | 1.036 | 26.31 | 1.0625-20 | .913 | 23.19 | 1.063 | 27.00 | |

JAM NUT PANEL CUTOUT

| Shell Size | A Flat | | B Dia. | |
|------------|--------------|---------------|--------------|---------------|
| | in. ±.002 | mm. ± 0.05 | in. ±.005 | mm. ± 0.13 |
| 5 | .423 | 10.74 | .448 | 11.38 |
| 6 | .475 | 12.07 | .510 | 12.95 |
| 7 | .602 | 15.29 | .635 | 16.13 |
| 8 | .602 | 15.29 | .635 | 16.13 |
| 9 | .663 | 16.84 | .698 | 17.73 |
| 10 | .729 | 18.82 | .760 | 19.30 |
| 12 | .851 | 21.62 | .885 | 22.48 |
| 14 | .976 | 24.79 | 1.010 | 25.65 |

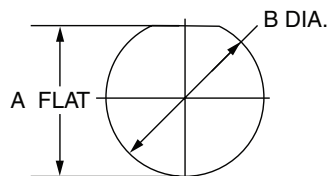

Hermetic

G

2M804 Front Panel Jam Nut Hermetic

2M804-006-00

2M804-006-00

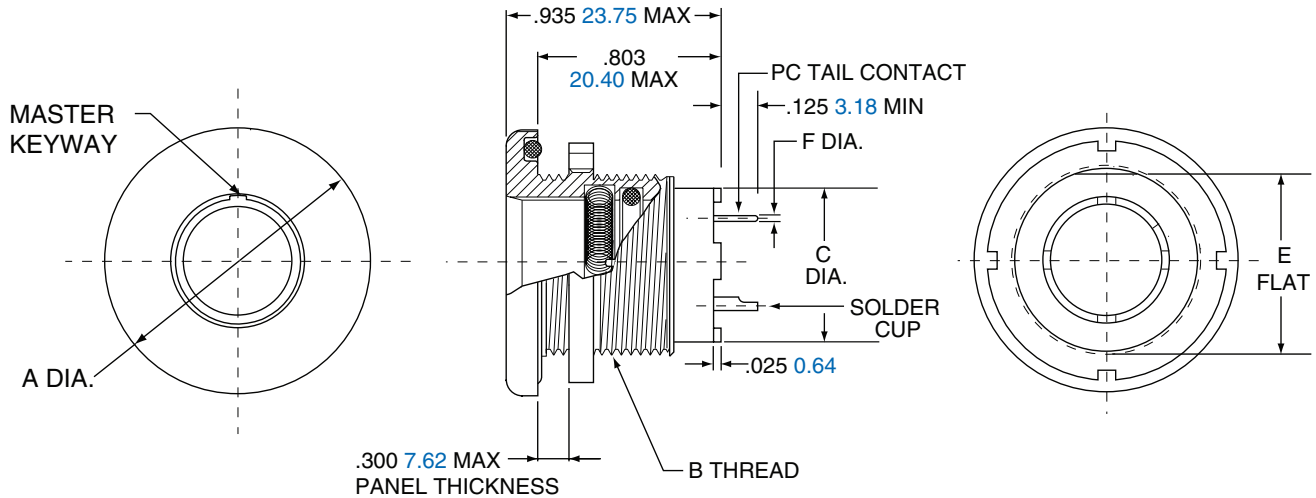

| Shell Size | A Dia. | | B Thread UN-2A | C Dia. | | E Flat. | | F PC Tail Dia. |
|------------|--------|-------|----------------|--------|-------|---------|-------|------------------------------------|
| | in. | mm. | | in. | mm. | in. | mm. | |
| 5 | .830 | 21.08 | .5000-32 | .274 | 6.96 | .470 | 11.94 | #23 .018/.022 0.46/0.56 |
| 6 | .884 | 22.45 | .5625-32 | .329 | 8.36 | .529 | 13.44 | |
| 7 | .994 | 25.25 | .6875-28 | .431 | 10.95 | .663 | 16.84 | #20/20HD .025/.027 0.64/0.69 |
| 8 | .994 | 25.25 | .6875-28 | .493 | 12.52 | .663 | 16.84 | |
| 9 | 1.073 | 27.25 | .7500-28 | .551 | 14.00 | .719 | 18.26 | #16 .060/.064 1.52/1.63 |
| 10 | 1.138 | 28.91 | .8125-28 | .619 | 15.72 | .778 | 19.76 | |
| 12 | 1.338 | 33.99 | 1.0000-28 | .703 | 17.86 | .969 | 24.61 | |
| 14 | 1.388 | 35.26 | 1.0625-20 | .863 | 21.92 | 1.019 | 25.88 | #12 .092/.096 2.34/2.44 |
| 15 | 1.453 | 36.91 | 1.1250-28 | .913 | 23.19 | 1.113 | 28.27 | |

JAM NUT PANEL CUTOUT

| Shell Size | A Flat | | B Dia. | |
|------------|--------------|---------------|--------------|---------------|
| | in. ±.002 | mm. ± 0.05 | in. ±.005 | mm. ± 0.13 |
| 5 | .477 | 12.12 | .510 | 12.95 |
| 6 | .537 | 13.64 | .635 | 16.13 |
| 7 | .670 | 17.02 | .635 | 16.13 |
| 8 | .670 | 17.02 | .698 | 17.73 |
| 9 | .727 | 18.47 | .760 | 19.30 |
| 10 | .787 | 19.81 | .885 | 22.48 |
| 12 | .977 | 24.82 | 1.010 | 25.65 |
| 14 | 1.027 | 26.09 | 1.073 | 27.25 |
| 15 | 1.120 | 28.45 | 1.135 | 28.83 |

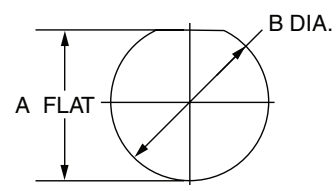

Hermetic



2M803 Hermetic

Ordering Guide for 2M803-006 Receptacles



2M803 Series of Hermetic Receptacles provide superior sealing of 1x10⁻⁸ cc/second helium leak rate and are 100% tested prior to shipping. This superior sealing is accomplished through the use of glass insulator fused to stainless steel shells and iron alloy contacts.

2M803 FEATURES INCLUDE:

- Low profile shells for minimum box protrusion
- Shell Standoffs for PC Board washout
- Non-removable PC and/or Solder cup contacts
- Hermetic Sealing

| 1. | 2. | 3. | 4. | 5. | 6. |
|-----------|------------|---------------|-------------------------|----------|--------|
| SERIES | SHELL SIZE | SERVICE CLASS | SHELL SIZE-INSERT AGGMT | CONTACTS | KEYING |
| 2M803-006 | -07 | Z1 | 6-7 | P | A |

Example Part Number

| 1. Series | |
|-----------|---|
| Part # | Description |
| 2M803-006 | Hermetic Receptacles with PCB Contacts or Solder Cup Contacts |

| 2. Shell Size | |
|---------------|--------------|
| Part # | Description |
| -02 | Flange Mount |
| -07 | Jam Nut |

| 3. Service Class | | | |
|------------------|--------|---------------------|--|
| Material | Part # | Description | |
| STAINLESS STEEL | Z1 | Passivated | |
| | ZL | Electrolytic Nickel | |

| 4. Shell Size-Insert Arrangement |
|----------------------------------|
| See Table pg 7-20 |

| 5. Contacts | |
|-------------|---|
| Part # | Description |
| P | Pin- Solder Cup |
| C | Pin-PC Tail |
| H | Pin, Solder Cup- Without Interfacial Seal |
| Y | Pin, PC Tail- Without Interfacial Seal |

| 6. Keying | | |
|------------|------|------|
| Part # | A° | B° |
| N (NORMAL) | 150° | 210° |
| X | 75° | 210° |
| Y | 95° | 230° |
| Z | 140° | 275° |

Note: Please contact the factory directly for a listing of tooled interfacial seals for the hermetically sealed connectors.

Please note, Amphenol standard 2M hermetic connector are provided less the interfacial seal. Please contact the factory for availability on the interfacial seal.

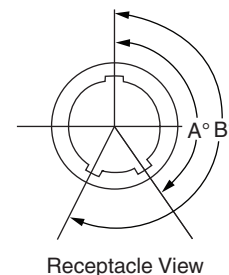

2M803 Hermetic

Flange Mount and Jam Nut 2M803-006-02 and -07

2M803-006-02

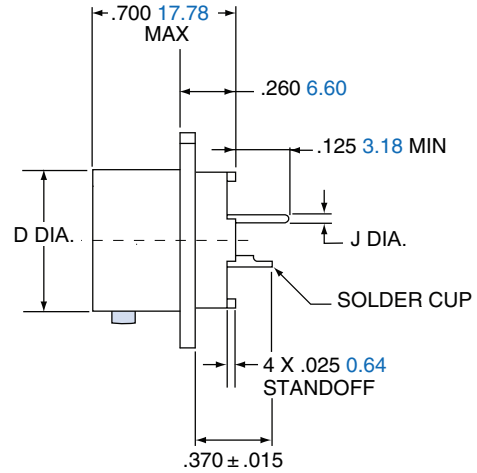
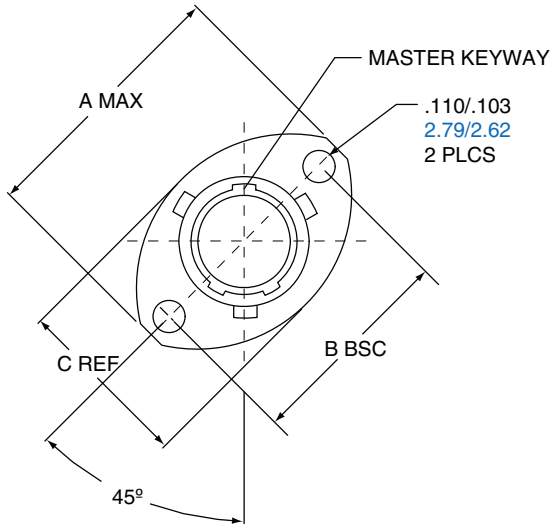

2M803-006-07

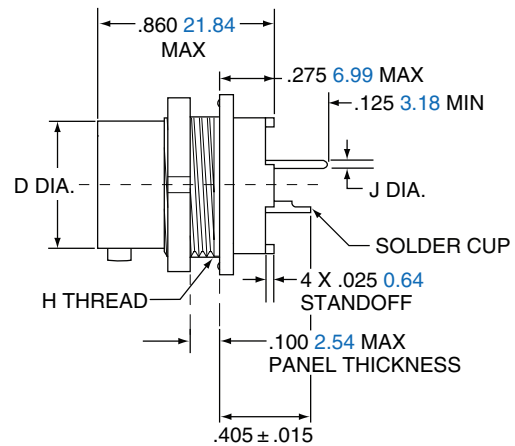
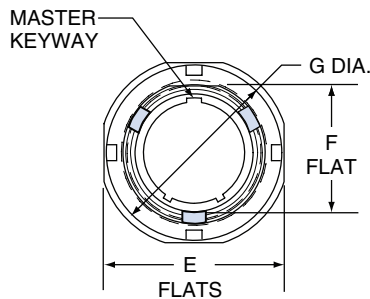

| Shell Size | A Max. | | B BSC. | | C Ref. | | D Dia. | | E Flats | | F Flat | | G Dia. | | H Thread | J PC Tail Dia. |
|------------|--------|-------|--------|-------|--------|-------|--------|-------|---------|-------|--------|-------|--------|-------|------------------|------------------------------------|
| | in. | mm | in. | mm | in. | mm | in. | mm | in. | mm | in. | mm | in. | mm | | |
| 5 | .710 | 18.03 | .513 | 13.03 | .460 | 11.68 | .300 | 7.62 | .545 | 13.84 | .350 | 8.89 | .575 | 14.61 | .3750-32 UNEF-2A | #23 .018/.022 0.46/0.56 |
| 6 | .788 | 20.02 | .598 | 15.19 | .522 | 13.26 | .362 | 9.19 | .595 | 15.11 | .410 | 10.42 | .635 | 16.13 | .4375-28 UNEF-2A | #20/20HD .025/.027 0.64/0.69 |
| 7 | .895 | 22.73 | .708 | 17.98 | .590 | 14.99 | .436 | 11.07 | .723 | 18.36 | .536 | 13.61 | .755 | 19.18 | .5625-32 UN-2A | #16 .060/.064 1.52/1.63 |
| 8 | 1.154 | 29.31 | .964 | 24.49 | .665 | 16.98 | .500 | 12.70 | .790 | 20.07 | .593 | 15.10 | .830 | 21.08 | .6250-28 UN-2A | #12 .092/.096 2.34/2.44 |
| 9 | 1.210 | 30.73 | 1.017 | 25.83 | .721 | 18.31 | .561 | 14.25 | .790 | 20.07 | .596 | 15.14 | .830 | 21.08 | .6250-28 UN-2A | |
| 10 | 1.291 | 32.79 | 1.101 | 27.97 | .795 | 20.19 | .635 | 16.13 | .925 | 23.51 | .721 | .721 | .955 | 24.26 | .7500-28 UN-2A | |
| 12 | 1.395 | 35.43 | 1.204 | 30.58 | .874 | 22.20 | .714 | 18.14 | 1.044 | 26.52 | .845 | 21.46 | 1.078 | 27.38 | .8750-28 UN-2A | |
| 14 | 1.550 | 39.37 | 1.280 | 32.51 | 1.050 | 26.67 | .865 | 21.97 | 1.230 | 31.24 | 1.022 | 25.96 | 1.264 | 32.11 | 1.0625-20 UN-2A | |
| 15 | N/A | N/A | N/A | N/A | N/A | N/A | .924 | 23.47 | 1.287 | 32.69 | 1.093 | 27.76 | 1.322 | 33.58 | 1.1250-28 UN-2A | |

2M801 Hermetic

Ordering Guide for Hermetic Receptacle 2M801-012



2M801 Series of Hermetic Receptacles provide superior sealing of 1x10⁻⁸ cc/second helium leak rate and are 100% tested prior to shipping. This superior sealing is accomplished through the use of glass insulator fused to stainless steel shells and iron alloy contacts.

2M801 FEATURES INCLUDE:

- Low profile shells for minimum box protrusion
- Shell Standoffs for PC Board washout
- Non-removable PC and/or Solder cup contacts
- Hermetic Sealing



| 1. SERIES | 2. SHELL SIZE | 3. SERVICE CLASS | 4. SHELL SIZE-INSERT AGGMT | 5. CONTACTS | 6. KEYING |
|-----------|---------------|------------------|----------------------------|-------------|-----------|
| 2M801-012 | -02 | Z1 | 6-7 | P | A |

Example Part Number

| 1. SERIES | |
|-----------|---|
| Part # | Description |
| 2M801-012 | Hermetic Receptacles with Printed Circuit Board Contacts or Solder cup contacts |

| 2. SHELL SIZE | |
|---------------|--|
| Part # | Description |
| -02 | Flange Mount |
| -03 | Weld Mount (only available is Z1 finish) |
| -07 | Jam Nut |

| 3. SERVICE CLASS | | | |
|------------------|--------|--|------|
| Material | Part # | Description | RoHS |
| STAINLESS STEEL | Z1 | Passivated | |
| | ZL | Electrolytic Nickel | |
| | ZB | Stainless Steel with Olive Drab Cadmium Finish | |

| 4. SHELL SIZE-INSERT ARRANGEMENT | |
|----------------------------------|--|
| See Table pg 7-20 | |

| 5. CONTACTS | |
|-------------|---|
| Part # | Description |
| P | Pin- Solder Cup |
| C | Pin-PC Tail |
| H | Pin, Solder Cup- Without Interfacial Seal |
| Y | Pin, PC Tail- Without Interfacial Seal |

| 6. KEYING | | |
|------------|------|------|
| Part # | A° | B° |
| A (NORMAL) | 150° | 210° |
| B | 75° | 210° |
| C | 95° | 230° |
| D | 140° | 275° |
| E | 75° | 275° |
| F | 95° | 210° |

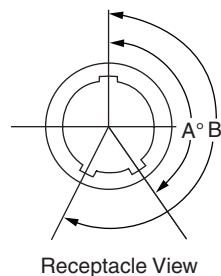

Note: Please contact the factory directly for a listing of tooled interfacial seals for the hermetically sealed connectors.

2M801 Hermetic

Hermetic Jam Nut Connector 2M801-012-07

2M801-012-07

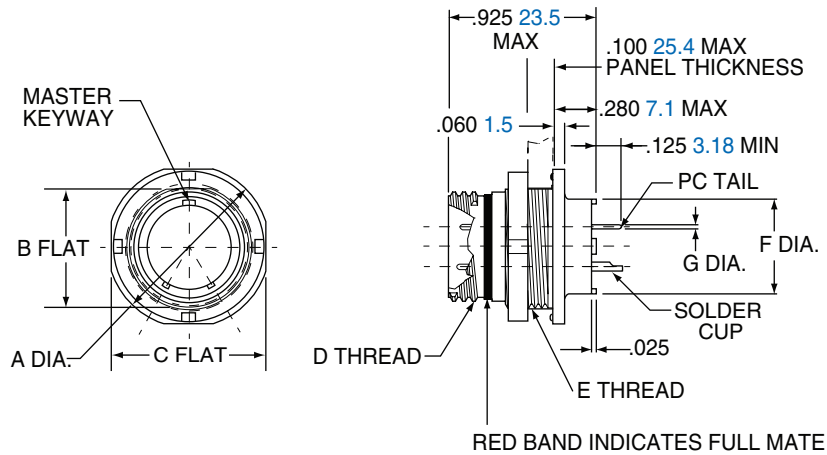

| Shell Size | A Dia. | | B Flat | | C Flat | | D Thread | UN-2A E Thread | F Dia. | | G Dia. Tail Dia. |
|------------|--------|-------|--------|-------|--------|-------|-------------------|-------------------|--------|-------|------------------------------------|
| | in. | mm. | in. | mm. | in. | mm. | | | in. | mm. | |
| 5 | .575 | 14.61 | .350 | 8.89 | .545 | 13.84 | .3125-.05P-.1L-2A | .3750-28 | .244 | 6.20 | #23 .018/.022 0.46/0.56 |
| 6 | .635 | 16.13 | .410 | 10.41 | .595 | 15.11 | .3750-.05P-.1L-2A | .4375-28 | .330 | 8.38 | |
| 7 | .755 | 19.18 | .536 | 13.61 | .723 | 18.36 | .4375-.05P-.1L-2A | .5625-32 | .432 | 10.97 | |
| 8 | .755 | 19.18 | .536 | 13.61 | .723 | 18.36 | .5000-.05P-.1L-2A | .5625-32 | .493 | 12.52 | #20/20HD .024/.028 0.64/0.69 |
| 9 | .830 | 21.08 | .596 | 15.14 | .790 | 20.07 | .5625-.05P-.1L-2A | .6250-28 | .551 | 14.00 | |
| 10 | .890 | 22.61 | .658 | 16.71 | .855 | 21.72 | .6250-.05P-.1L-2A | .6875-28 | .620 | 15.75 | #16 |
| 13 | 1.078 | 27.38 | .845 | 21.46 | 1.044 | 26.52 | .8125-.1P-.2L-2A | .8750-28 | .703 | 17.86 | .060/.064 1.52/1.63 |
| 16 | 1.264 | 32.11 | 1.022 | 25.96 | 1.230 | 31.24 | 1.0000-.1P-.2L-2A | 1.0625-20 | .863 | 21.92 | |
| 17 | 1.325 | 33.66 | 1.096 | 27.84 | 1.290 | 32.77 | 1.0625-.1P-.2L-2A | 1.125-28 | .912 | 23.16 | #12 .092/.096 2.34/2.44 |
| 21 | 1.625 | 41.28 | 1.345 | 34.16 | 1.577 | 40.06 | 1.3125-.1P-.2L-2A | 1.375-28 | 1.170 | 29.72 | |

PANEL CUTOUT

| Shell Size | A Flat | | B Dia. | |
|------------|--------------|---------------|--------------|---------------|
| | in. ±.002 | mm. ± 0.05 | in. ±.002 | mm. ± 0.05 |
| 5 | .356 | 9.04 | .385 | 9.78 |
| 6 | .416 | 10.57 | .447 | 11.35 |
| 7 | .542 | 13.77 | .572 | 14.53 |
| 8 | .542 | 13.77 | .572 | 14.53 |
| 9 | .602 | 15.29 | .635 | 16.13 |
| 10 | .666 | 16.92 | .697 | 17.70 |
| 13 | .851 | 21.62 | .885 | 22.48 |
| 16 | 1.028 | 26.11 | 1.075 | 27.31 |
| 17 | 1.102 | 27.99 | 1.135 | 28.83 |
| 21 | 1.354 | 34.39 | 1.385 | 35.18 |

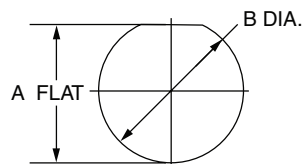

2M801 Dual-Start ACME Threads

Hermetic Square Flange Connector 2M801-012-02



2M801-012-02

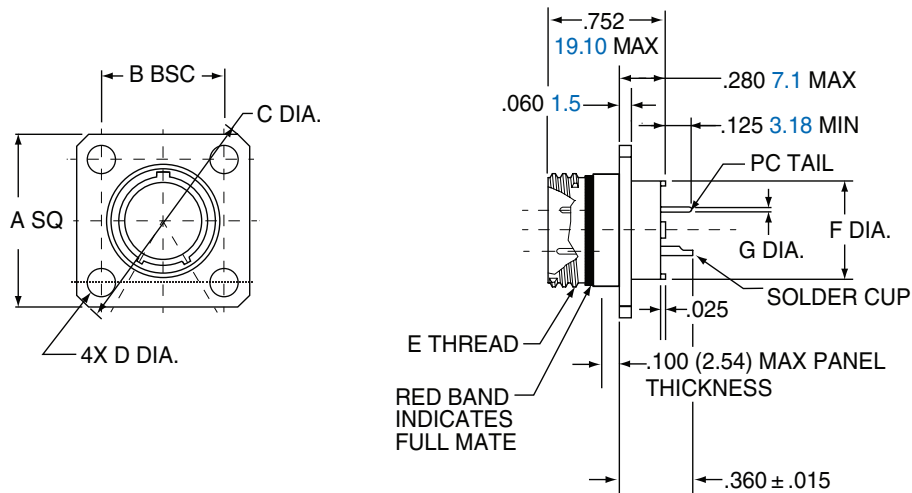

| Shell Size | A SQ. | | B BSC | | C Dia. | | D Dia. | | E Thread | F Dia. | | G. Dia. Tail Dia. |
|------------|-------|-------|-------|-------|--------|-------|-----------|------------|-------------------|--------|-------|------------------------------------|
| | in. | mm. | in. | mm. | in. | mm. | in. ±.003 | mm. ± 0.08 | | in. | mm. | |
| 5 | .530 | 13.46 | .363 | 9.22 | .680 | 17.27 | .093 | 2.36 | .3125-.05P-.1L-2A | .244 | 6.20 | #23 .018/.022 0.46/0.56 |
| 6 | .590 | 14.99 | .423 | 10.74 | .750 | 19.05 | .093 | 2.36 | .3750-.05P-.1L-2A | .330 | 8.38 | #20/20HD .025/.027 0.64/0.69 |
| 7 | .650 | 16.51 | .483 | 12.27 | .850 | 21.59 | .093 | 2.36 | .4375-.05P-.1L-2A | .432 | 10.97 | #16 .060/.064 1.52/1.63 |
| 8 | .712 | 18.08 | .545 | 13.84 | .938 | 23.83 | .093 | 2.36 | .5000-.05P-.1L-2A | .493 | 12.52 | #12 .092/.096 2.34/2.44 |
| 9 | .850 | 21.56 | .607 | 15.42 | 1.125 | 28.58 | .128 | 3.25 | .5625-.05P-.1L-2A | .551 | 14.00 | |
| 10 | .890 | 22.61 | .670 | 17.02 | 1.188 | 30.18 | .128 | 3.25 | .6250-.05P-.1L-2A | .620 | 15.75 | |
| 13 | 1.030 | 26.16 | .812 | 20.62 | 1.375 | 34.93 | .128 | 3.25 | .8125-.1P-.2L-2A | .703 | 17.86 | |
| 16 | 1.219 | 31.96 | .981 | 24.92 | 1.625 | 41.28 | .128 | 3.25 | 1.0000-.1P-.2L-2A | .863 | 21.92 | |
| 17 | 1.280 | 32.51 | 1.060 | 26.92 | 1.700 | 43.18 | .128 | 3.25 | 1.0625-.1P-.2L-2A | .912 | 23.16 | |
| 21 | 1.430 | 36.32 | 1.205 | 30.61 | 1.940 | 49.28 | .128 | 3.25 | 1.3125-.1P-.2L-2A | 1.170 | 29.72 | |

PANEL CUTOUT

| Shell Size | A Dia. | | B BSC | | C Dia. | |
|------------|--------|-------|-------|-------|--------|------|
| | in. | mm. | in. | mm. | in. | mm. |
| 5 | .330 | 8.38 | .363 | 9.22 | .093 | 2.36 |
| 6 | .390 | 9.91 | .423 | 10.74 | .093 | 2.36 |
| 7 | .450 | 11.43 | .483 | 12.27 | .093 | 2.36 |
| 8 | .510 | 12.95 | .545 | 13.84 | .093 | 2.36 |
| 9 | .575 | 14.61 | .607 | 15.42 | .128 | 3.25 |
| 10 | .640 | 16.26 | .670 | 17.02 | .128 | 3.25 |
| 13 | .825 | 20.96 | .812 | 20.65 | .128 | 3.25 |
| 16 | 1.015 | 25.78 | .981 | 24.92 | .128 | 3.25 |
| 17 | 1.075 | 27.31 | 1.060 | 26.92 | .128 | 3.25 |
| 21 | 1.325 | 33.66 | 1.205 | 30.61 | .128 | 3.25 |

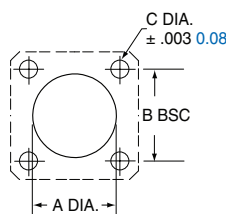

2M801 Dual-Start ACME Threads

Hermetic Weld Mount Connector 2M801-012-03

2M801-012-03

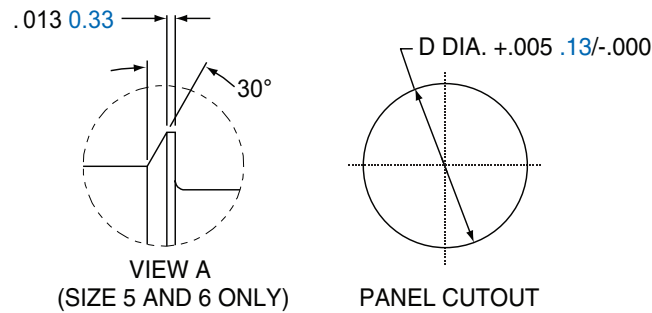
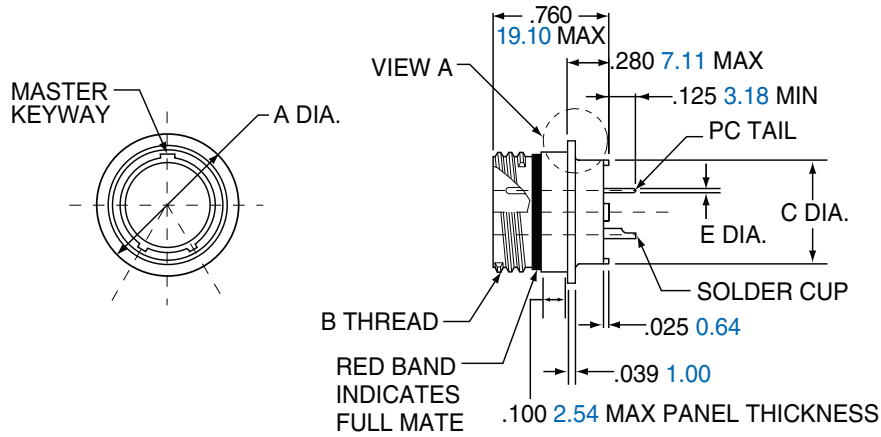

| Shell Size | A Dia | | B Thread | C Dia. | | D Dia. Panel Cutout | | G. PC Tail Dia. |
|------------|-------|-------|-------------------|--------|-------|---------------------|-------|------------------------------------|
| | in. | mm. | | in. | mm. | in. | mm. | |
| 5 | .395 | 10.03 | .3125-.05P-.1L-2A | .244 | 6.20 | .319 | 8.10 | #23 .018/.022 0.46/0.56 |
| 6 | .455 | 11.56 | .3750-.05P-.1L-2A | .330 | 8.38 | .379 | 9.55 | |
| 7 | .520 | 13.21 | .4375-.05P-.1L-2A | .432 | 11.97 | .438 | 11.13 | #20/20HD .024/.028 0.64/0.69 |
| 8 | .580 | 14.73 | .5000-.05P-.1L-2A | .493 | 12.52 | .502 | 11.13 | |
| 9 | .645 | 16.38 | .5625-.05P-.1L-2A | .551 | 14.00 | .563 | 14.30 | #16 .060/.064 1.52/1.63 |
| 10 | .705 | 18.01 | .6250-.05P-.1L-2A | .620 | 15.75 | .627 | 11.13 | |
| 13 | .895 | 22.73 | .8125-.1P-.2L-2A | .703 | 17.86 | .814 | 20.68 | #12 .092/.096 2.34/2.44 |
| 16 | 1.080 | 27.43 | 1.0000-.1P-.2L-2A | .863 | 21.92 | 1.007 | 25.58 | |
| 17 | 1.145 | 29.08 | 1.0625-.1P-.2L-2A | .912 | 23.16 | 1.067 | 27.10 | |
| 21 | 1.395 | 35.43 | 1.3125-.1P-.2L-2A | 1.170 | 29.72 | 1.320 | 33.53 | |

For 2M Filtered High Density Connectors, Look to the leader...

Amphenol® EMI Protection Connectors have been designed and manufactured for over 45 years. Our EMI protection connectors offer the versatility of our standard 2M connectors with EMI protection to suit the demands of your application.

Advantages of Filter Connectors

- Reduction in overall weight and space with the elimination of external filtering
- Reduction in solder joints
- Fewer components equals a cost effective solution with increased reliability
- Eliminates radiated and conducted EMI from entering the box
- Perfect for retrofits or late design-in
- Can utilize standard connector packaging



Resources

Amphenol Aerospace Factory Direct: 607.563.5011
Filter Technical Support: FilterApps@Amphenol-aa.com

Quality

All filter connectors undergo extensive mechanical and electrical testing to ensure consistent, quality hardware.

Standard Electrical Tests

- 100% Insulation Resistance testing
- 100% Dielectric Withstanding Voltage testing
- 100% Capacitance testing at 1KHz

Special Tests/Processes Available

- Attenuation testing (through 100 MHz)
- Leakage inspection
- Thermal cycling/shock
- Burn-in
- De-gassing

**AMPHENOL WILL WORK TO PROVIDE THE BEST SOLUTION IN
STANDARD 2M PACKAGING FOR THE MOST COST
EFFECTIVE SOLUTIONS AVAILABLE**

Filtered 2M Attenuation Characteristics

Note: Below are typical capacitance values. Other capacitance values are available. Please consult Amphenol Aerospace for availability.

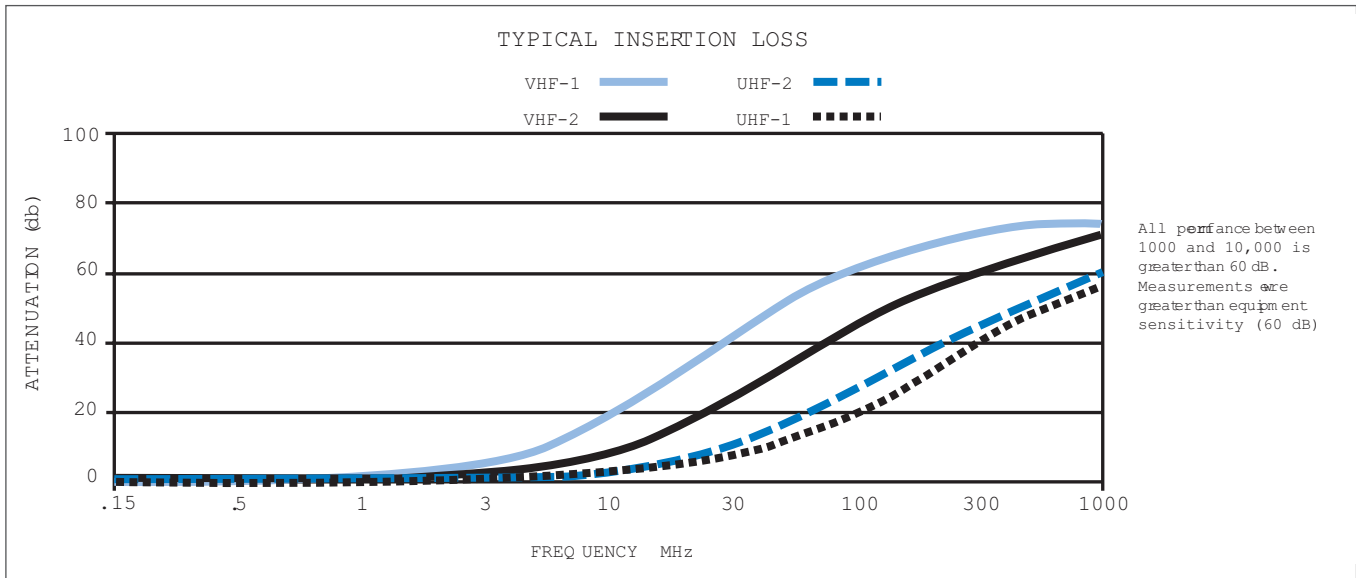

**TYPICAL INSERTION LOSS (dB)
PER MIL-STD-220, 5 ADC, 25°C**

| Capacitance | 1MHz | 3MHz | 10MHz | 30MHz | 100MHz | 300MHz | 1000MHz |
|--------------------------|------|------|-------|-------|--------|--------|---------|
| 375 pf UHF ₁ | 0 | 0 | 1 | 8 | 16 | - | - |
| 750 pf UHF ₂ | 0 | 0 | 3 | 10 | 19 | - | - |
| 2500 pf VHF ₂ | 0 | 2 | 8 | 20 | 28 | - | - |
| 7000 pf VHF ₁ | 5 | 9 | 17 | 23 | 40 | - | - |

Most filter attenuation curves and capacitance values are expressed at 25°C. However, temperature can affect the capacitance of a barium titanate filter element, affecting the insertion loss that the element will cause. In order to assist the user in anticipating the effect of various temperatures, the following charts applicable to Amphenol filter connectors utilizing VHF-1, VHF-2, UHF-1 and UHF-2 filters are provided. Please note that all insertion loss (attenuation) values given were measured with no load applied. The band designations refer to MIL-STD-2120.

VHF-1

Typical Capacitance = 7,000 pf Min. 4,900 pf Max. 12,000 pf
Band G, Type Pi

| Temp. | F _{co} | 1MHz | 3MHz | 10MHz | 30MHz | 100MHz | 300MHz | 1000MHz |
|--------|-----------------|------|------|-------|-------|--------|--------|---------|
| -55°C | - | 1 | 2 | 8 | 21 | 44 | 61 | 65 |
| Room | 1.27M | 1 | 6 | 18 | 42 | 62 | 72 | 75 |
| +125°C | - | 0 | 2 | 9 | 24 | 45 | 62 | 64 |

Note: F_{co} = Cut-off Frequency

VHF-2

Typical Capacitance = 2,500 pf Min. 1,900 pf Max. 4,000 pf
Band E, Type Pi

| Temp. | F _{co} | 1MHz | 3MHz | 10MHz | 30MHz | 100MHz | 300MHz | 1000MHz |
|--------|-----------------|------|------|-------|-------|--------|--------|---------|
| -55°C | - | 0 | 2 | 7 | 17 | 40 | 58 | 71 |
| Room | 3.3M | 0 | 2 | 8 | 24 | 46 | 61 | 71 |
| +125°C | - | 0 | 3 | 10 | 26 | 46 | 63 | 69 |

UHF-1

Typical Capacitance = 375 pf Min. 290 pf Max. 450 pf
Band B, Type Pi

| Temp. | F _{co} | 1MHz | 3MHz | 10MHz | 30MHz | 100MHz | 300MHz | 1000MHz |
|--------|-----------------|------|------|-------|-------|--------|--------|---------|
| -55°C | - | 0 | 0 | 1 | 6 | 21 | 43 | 58 |
| Room | 21.9M | 0 | 0 | 1 | 8 | 18 | 42 | 56 |
| +125°C | - | 0 | 0 | 1 | 8 | 17 | 38 | 50 |

UHF-2

Typical Capacitance = 750 pf Min. 500 pf Max. 1,100 pf
Band C, Type Pi

| Temp. | F _{co} | 1MHz | 3MHz | 10MHz | 30MHz | 100MHz | 300MHz | 1000MHz |
|--------|-----------------|------|------|-------|-------|--------|--------|---------|
| -55°C | - | 0 | 0 | 3 | 9 | 25 | 46 | 61 |
| Room | 12.7M | 0 | 0 | 3 | 10 | 28 | 46 | 61 |
| +125°C | - | 0 | 0 | 3 | 10 | 24 | 42 | 60 |

Please consult the Amphenol Circular Interconnects catalog 12-C Edition 4 for full Amphenol EMI/EMP Filter Protection information.

Page Guide

| | |
|-----------------------|-----------|
| Contact/ Tools | J98 |
| Assembly | J99-100 |
| Plugs/ Tools..... | J101, 102 |
| Strain Relief Clamp . | J103, 104 |
| Micro Band | |
| Adapter..... | J105-108 |
| Enviromental | |
| Backshells | J109, 110 |
| EMI Backshells | J111-114 |
| Shortening Cap | |
| Backshell..... | J115, 116 |
| Shrink Boots | J117, 118 |
| Hex Jam Nut..... | J119 |
| Flange Gasket..... | J120, 121 |
| O Rings..... | J122 |

2M Accessories, Contacts, and tools

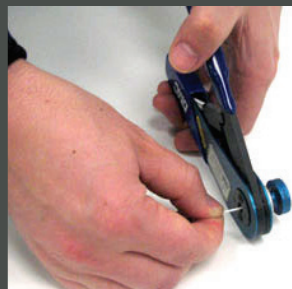

2M

2M Series Contacts and Tools

Crimp Contacts

| Contact Size | Type | AMPS | Wire Size AWG | Part Number | Color Band | | |
|--------------|--------|------|---------------|----------------------|------------|-------|--------|
| | | | | | 1st | 2nd | 3rd |
| #23 | Pin | 5 | #22-#28 | 2M809-001 | N/A | N/A | N/A |
| | Pin | | #26-#30 | 2M809-042* | Blue | N/A | N/A |
| | Socket | | #22-#28 | 2M809-002 | N/A | N/A | N/A |
| | Socket | | #26-#30 | 2M809-043* | Blue | N/A | N/A |
| #20HD | Pin | 7.5 | #20-#24 | 2M809-204 | N/A | N/A | N/A |
| | Socket | | #20-#24 | 2M809-205 | N/A | N/A | N/A |
| #20 | Pin | 7.5 | #20-#24 | M39029/58-363 | Orange | Blue | Orange |
| | Socket | | #20-#24 | M39029/57-357 | Orange | Green | Violet |
| #16 | Pin | 13 | #16-#20 | M39029/58-364 | Orange | Blue | Orange |
| | Socket | | #16-#20 | M39029/57-358 | Orange | Green | Gray |
| #12 | Pin | 23 | #12-#14 | M39029/58-365 | Orange | Blue | Green |
| | Socket | | #12-#14 | M39029/57-359 | Orange | Green | White |



*Special order please consult Amphenol-Aerospace for information.

Contact Tools

| Contact Size | Tooling Part Numbers | | |
|--------------|----------------------|-----------------------|--|
| | Crimper | Positioner | Insertion/ Removal Number |
| #23 | M22520/2-01 | K1461-1* (Daniels) | DAK225-22* (Daniels Insertion Only) |
| | | | 2M809-23R (Removal only) |
| #20HD | M22520/2-01 | 2M809-206 | 2M809-20HDR (Removal only) |
| #20 | M22520/1-01 | M22520/1-04 | M81969/14-10 |
| #16 | M22520/1-01 | M22520/1-04 | M81969/14-03 |
| #12 | M22520/1-01 | M22520/1-04 | M81969/14-04 |

*Daniels Manufacturing Co. part number

Crimp Tensile Strength

| Contact Size | Wire Gage | Silver or Tin Coated Copper Wire | Nickel Coated Copper Wire |
|--------------|-----------|----------------------------------|---------------------------|
| #23, #20HD | #22 | 12 | 8 |
| #23, #20HD | #24 | 8 | 6 |
| #23 | #26 | 5 | 3 |
| #23 | #28 | 3 | 2 |
| #23 | #30 | 1.5 | 1.5 |

Tensile Strength for size #23 and #20HD only
Values represent minimums and are in pounds

Series 2M Torque Values

| Shell Size Series 2M801, 2M803 | Shell Size Series 2M805 | Coupling Torque | | | | Jam Nut Tightening | | | | Backshell Tightening | | | |
|--------------------------------|-------------------------|-----------------|------|------|------|--------------------|------|------|------|----------------------|------|------|------|
| | | In-LBs. | | N-m | | In-LBs. | | N-m | | In-LBs. | | N-m | |
| | | Min. | Max. | Min. | Max. | Min. | Max. | Min. | Max. | Min. | Max. | Min. | Max. |
| 5 | - | 25 | 35 | 2.8 | 4.0 | 20 | 25 | 2.2 | 2.8 | 13 | 17 | 1.5 | 1.9 |
| 6 | 8 | 35 | 40 | 4.0 | 4.5 | 20 | 25 | 2.2 | 2.8 | 18 | 22 | 2.0 | 2.5 |
| 7 | 9 | 35 | 40 | 4.0 | 4.5 | 20 | 25 | 2.2 | 2.8 | 30 | 40 | 3.4 | 4.5 |
| 8 | 10 | 40 | 50 | 4.5 | 5.7 | 20 | 25 | 2.2 | 2.8 | 30 | 40 | 3.4 | 4.5 |
| 9 | 11 | 40 | 50 | 4.5 | 5.7 | 20 | 25 | 2.2 | 2.8 | 35 | 45 | 4.0 | 5.1 |
| 10 | 12 | 50 | 60 | 5.7 | 6.8 | 25 | 30 | 2.8 | 3.3 | 35 | 45 | 4.0 | 5.1 |
| 12, 13 | 15 | 50 | 60 | 5.7 | 6.8 | 25 | 30 | 2.8 | 3.3 | 35 | 45 | 4.0 | 5.1 |
| 14, 16 | 18 | 55 | 65 | 6.2 | 7.3 | 25 | 30 | 2.8 | 3.3 | 35 | 45 | 4.0 | 5.1 |
| 15, 17 | 19 | 55 | 65 | 6.2 | 7.3 | 25 | 30 | 2.8 | 3.3 | 35 | 45 | 4.0 | 5.1 |
| 21 | 23 | 55 | 65 | 6.2 | 7.3 | 25 | 30 | 2.8 | 3.3 | 35 | 45 | 4.0 | 5.1 |

2M Series Assembly Instructions



Wire Stripping

1. Strip wire to required length. (See Figure at right). When using hot wire stripping, do not wipe melted insulation material on wire strands; with mechanical strippers do not cut or nick strands.
2. See Table 1 for proper finished outside wire dimensions.
3. Twist strands together to form a firm bundle.
4. Insert stripped wire into contact applying slight pressure until wire insulation butts against wire well. Check inspection hole to see that wire strands are visible. If there are strayed wire strands, entire wire end should be re-twisted. When wire is stripped and properly installed into contact, the next step is to crimp the wire inside the contact by using the proper crimping tool.

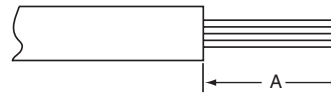

Stripping Dimensions

| Wire Size | A |
|-----------|-------------|
| 23 | .115 (2.92) |
| 20/20HD | .188 (4.77) |
| 16 | .188 (4.77) |
| 12 | .188 (4.77) |

Table 1

| Contact Size | Wire Dimension (inches)** | |
|--------------|---------------------------|------|
| | Min. | Max. |
| 10 | .135 | .162 |
| 12 | .097 | .142 |
| 16 | .065 | .109 |
| 20/20HD | .040 | .077 |
| 23 | .025 | .048 |

** Min. diameters to insure moisture proof assembly; max. diameters to permit use of metal removal tools.

Crimping

See table on preceding page for more information on crimp contacts, contact tools, and crimp tensile strength

1. Insert stripped wire into contact crimp pot. Wire must be visible through inspection hole.
2. Using correct crimp tool and locator, cycle the tool once to be sure the indentors are open, insert contact and wire into locator. Squeeze tool handles firmly and completely to insure a proper crimp. The tool will not release unless the crimp indentors in the tool head have been fully actuated.
3. Release crimped contact and wire from tool. Be certain the wire is visible through inspection hole in contact.

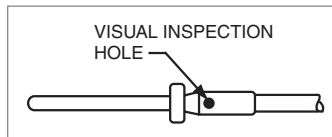

Examples of M22520 Series Crimping Tools:
Shown top: tool used for small size 23 contacts.
Shown bottom: tool used for size 20, 16 or 12 contacts and has a positioner that can be dialed for each contact size.

Contact Insertion

1. First remove hardware from the plug and receptacle and slide the hardware over wires in proper sequence.
2. Use proper plastic or metal insertion tool for corresponding contact. (Consult Insertion Tool table on preceding page). Slide correct tool (with plastic tool use colored end) over wire insulation and slide forward until tool bottoms against rear contact shoulder.
3. Next align the tool and contact up to the properly identified cavity at rear of connector plug. Use firm, even pressure; do not use excessive pressure. It is recommended to start at the center cavity. Contact must be aligned with grommet hole and not inserted at an angle. Push forward until contact is felt to snap into position within insert.

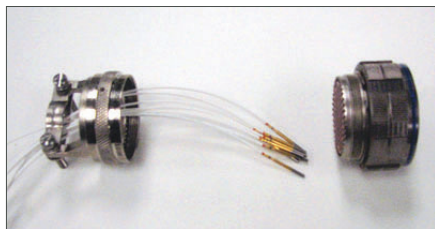

Note: All plastic tools are double-ended. The colored side is the insertion tool and the white side is the removal tool.

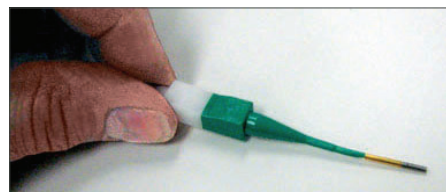

Plastic tool with contact in proper position.



Metal tool with contact.

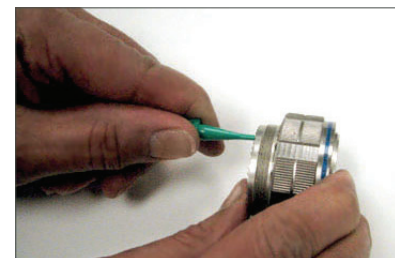

Continued on next page.

2M Series

Assembly Instructions

CONTACT INSERTION, CONT.

- Remove tool and pull back lightly on wire, making sure contact stays properly seated and isn't dragged back with the tool. Repeat operation with remainder of contacts to be inserted, beginning with the center cavity and working outward in alternating rows.

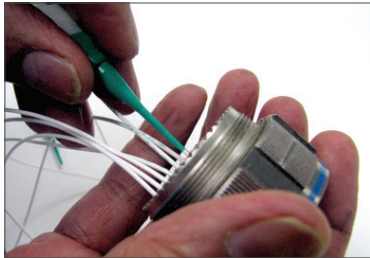

CAUTION: when inserting or removing contacts, do not spread or rotate tool tips.

- After all contacts are inserted, fill any empty cavities with wire sealing plugs.

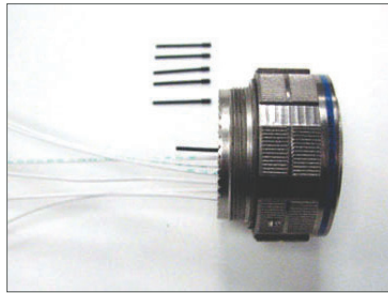

- Reassemble plug or receptacle hardware slide forward and tighten using connector pliers. Connector holding tools are recommended while tightening back accessories. When using strain relief, center wires at bar clamp. Slide clamp grommet into position and tighten clamp bar screws. When tightening screws, pressure should be applied in the same direction that clamp is threaded to rear threads of connector. When not using clamp grommet, build up wire bundle with vinyl tape so clamp bar will maintain pressure on wires.



CONTACT REMOVAL

- Remove hardware from plug or receptacle and slide hardware back along wire bundle.

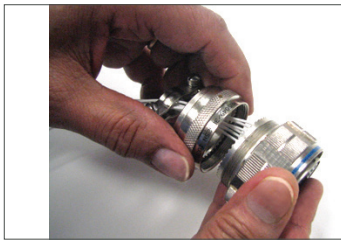

- Use proper plastic or metal removal tool for corresponding contact. Slide correct size tool over wire insulation.

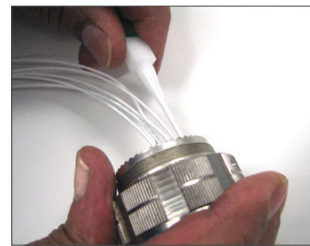

Use white end of plastic tool for removal of contacts.

- Insert plastic or metal removal tool into contact cavity until tool tips enter rear grommet and come to a positive stop. Hold tool tip firmly against positive stop on contact shoulder. Grip wire and simultaneously remove tool and contact. (On occasion, it may be necessary to remove tool, rotate 90° and reinsert.)

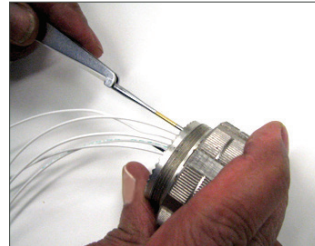

Removal of contacts with metal tool.

CAP ATTACHMENT TO JAM NUT RECEPTACLE

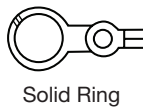
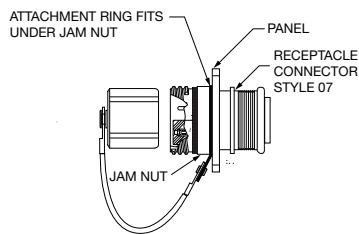

CAP ATTACHMENT TO PANEL

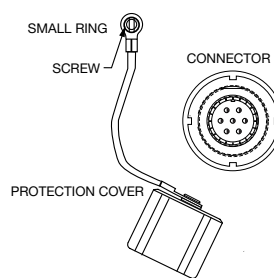

Small Ring for Attaching Receptacle Covers to a Panel with a Screw

CAP ATTACHMENT TO CABLE ASSEMBLY

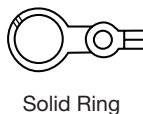
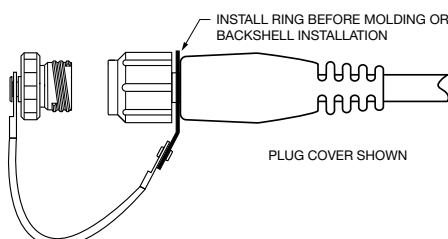

REMOVABLE CAP ATTACHMENT TO CABLE

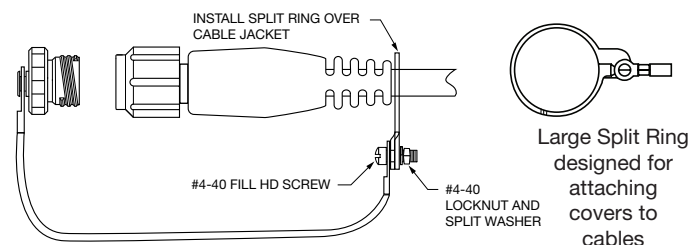

Large Split Ring designed for attaching covers to cables

2M Series Contacts and Tools

Grommet Sealing Plugs, Spanner Tool & Holding Tool



Grommet Sealing Plugs

| Size | Color | Part Number | Military Part Number |
|------|--------|-------------|----------------------|
| #23 | Black | 2M809-155 | MS27488-22-2 |
| #20 | Red | 2M859-012 | MS27488-20-2 |
| #16 | Green | 2M859-013 | MS27488-16-2 |
| #12 | Orange | 2M859-014 | MS27488-12-2 |

Spanner Tool for Tightening Series 2M Jam Nuts

| Shell Size | Holding Tool Part Number (Add P or R) | | | | |
|------------|---------------------------------------|--------------|-----------------------|-----------------------|--------------|
| | Series 2M801 | Series 2M803 | Series 2M804 Style 07 | Series 2M804 Style 00 | Series 2M805 |
| 5 | 2M600-146-02 | 2M600-137-05 | 2M600-146-03 | 2M600-147-05 | |
| 6 | 2M600-146-03 | 2M600-137-06 | 2M600-146-04 | 2M600-147-06 | |
| 7 | 2M600-146-05 | 2M600-137-07 | 2M600-146-06 | 2M600-147-07 | |
| 8 | 2M600-146-05 | 2M600-137-08 | 2M600-146-06 | 2M600-147-07 | 2M600-154-08 |
| 9 | 2M600-146-06 | 2M600-137-09 | 2M600-146-07 | 2M600-147-09 | 2M600-154-09 |
| 10 | 2M600-146-07 | 2M600-137-10 | 2M600-146-08 | 2M600-147-10 | 2M600-154-09 |
| 11 | | | | | 2M600-154-11 |
| 12 | | 2M600-137-12 | 2M600-141-10 | 2M600-147-12 | 2M600-154-12 |
| 13 | 2M600-146-10 | | | | |
| 14 | | 2M600-137-14 | 2M600-141-12 | 2M600-147-14 | |
| 15 | | 2M600-137-15 | 2M600-141-13 | 2M600-147-15 | 2M600-154-15 |
| 16 | 2M600-146-13 | | | | |
| 17 | 2M600-146-14 | | | | |
| 18 | | | | | 2M600-154-18 |
| 19 | | | | | 2M600-154-19 |
| 21 | 2M600-146-17 | | | | |
| 23 | | | | | 2M600-154-23 |

Connector Holding Tool for Tightening Backshells Accessories

| Shell Size | Holding Tool Part Number (Add P or R) | | | |
|------------|---------------------------------------|---------------|----------------|----------------|
| | Series 2M801 • | Series 2M803* | Series 2M804 × | Series 2M805 • |
| 5 | 2M600MM005-05 | 2M600-140-5 | 2M600-141-5 | |
| 6 | 2M600MM005-06 | 2M600-140-6 | 2M600-141-6 | |
| 7 | 2M600MM005-07 | 2M600-140-7 | 2M600-141-7 | |
| 8 | 2M600MM005-08 | 2M600-140-8 | 2M600-141-8 | 2M600-155-8 |
| 9 | 2M600MM005-09 | 2M600-140-9 | 2M600-141-9 | 2M600-155-9 |
| 10 | 2M600MM005-10 | 2M600-140-10 | 2M600-141-10 | 2M600-155-10 |
| 11 | | | | 2M600-155-11 |
| 12 | | 2M600-140-12 | 2M600-141-12 | 2M600-155-12 |
| 13 | 2M600MM005-13 | | | |
| 14 | | 2M600-140-14 | 2M600-141-14 | |
| 15 | | 2M600-140-15 | 2M600-141-15 | 2M600-155-15 |
| 16 | 2M600MM005-16 | | | |
| 17 | 2M600MM005-17 | | | |
| 18 | | | | 2M600-155-18 |
| 19 | | | | 2M600-155-19 |
| 21 | 2M600MM005-21 | | | |
| 23 | | | | 2M600-155-23 |



*Add P for Plug holder or R for receptacle holder, followed by polarizing position (N, X, Y, Z)

• Add P for Plug holder or R for Receptacle holder, followed by polarizing position (A, B, C, D).

× Add P for Plug holder or R for Receptacle holder.

2M Series Contacts and Tools

Micro Band Shield Termination Tool

Micro Band Shield Termination System:

Micro Band Termination: For assembling cables to overmolded style 2M connectors or backshells, the Micro Band System offers quick termination of cable shields and flexibility to be utilized on a wide range of parts with just one band size. These rugged straps have passed numerous hazardous environmental testing, including shock and vibration. Approved for use in military and aerospace applications.

MATERIALS:

Micro Band Installation Tool. Use with .120" (3.05 mm) wide bands. 6.75 inches (172 mm.) length, 1.2 pounds (0.6 Kg.)

Micro Band, .120" (3.05 mm) wide. Available in two lengths, flat or pre-coiled. Stainless steel.



| Description | Part Number |
|------------------------------|------------------|
| Micro Band Installation Tool | 2M600-061 |

| Length | | Part Number | Accommodates Diameter | |
|--------|--------|------------------|-----------------------|-------|
| inch | mm | | Flat | inch |
| 8.125 | 206.38 | 2M600-057 | .88 | 22.35 |
| 14.250 | 361.95 | 2M600-083 | 1.88 | 47.75 |

Micro Band Shield Termination Instructions:

1. Prepare cable braid for termination process (Figure 1).
2. Push braid forward over adapter retention lip to the adapter incline point (or .4" [10.2mm] minimum braid length). Milk braid as required to remove slack and ensure a snug fit around the shield termination area (Figure 2).
3. Prepare the band in the following manner: **IMPORTANT:** Due to connector/adaptor circumference, it may be necessary to prepare the band around the cable or retention area.
 - A. Roll band through the buckle slot twice. (Band must be double-coiled!)
 - B. Pull on band until mark (▷) is within approximately .250 inch (6.4mm) of buckle slot (Figure 3). The band may be tightened further if desired.

NOTE: Prepared band should have this (▷) mark visible approximately where shown in Figure 3.

Shield Termination Clamping Process (Figures 4 thru 8)

NOTE: To free tool handles, squeeze handles together and move holding clips to center of tool.

4. Squeeze gray gripper release lever and insert band into the front end opening of the tool. (Circular portion of looped band must always face downward.)

5. Aligning the band and tool with the shield termination area, squeeze blue pull-up handle repeatedly in full strokes until it locks against tool body. (This indicates the band is compressed to the tool precalibrated tension.)

NOTE: To loosen or remove band before locking and cut-off, squeeze gray grip per release lever on tool and pull band out. To loosen or remove band after blue pull-up handle locks against tool body, squeeze pull-up handle and push tension release lever on top of tool forward. Let tension handle return to original position and use the gripper release lever to remove band.
6. Complete the clamping process by squeezing the black cut-off handle to form lock and trim excess band. To remove excess band from tool, squeeze gray gripper release handle, pull out and dispose. Inspect shield termination.

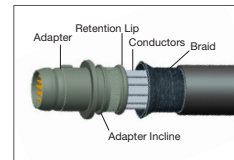

Fig. 1

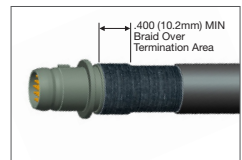

Fig. 2

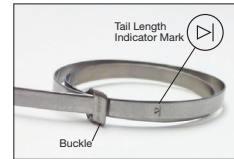

Fig. 3



Fig. 4

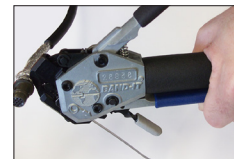

Fig. 5

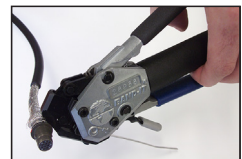

Fig. 6



Fig. 7

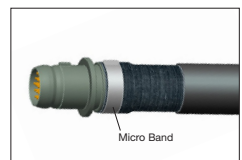

Fig. 8

2M Strain Relief Clamp Ordering Information

2M620MS064 and 2M620MS065



| 1. | 2. | 3. |
|-------------|---------------|-----------|
| PART NUMBER | SERVICE CLASS | SIZE CODE |
| 2M620MS06X | -M | 07 |



| 1. PART NUMBER | |
|----------------|--------------------|
| Part # | Description |
| 2M620MS065 | Rotatable Coupling |
| 2M620MS064 | Direct Coupling |

| 2. SERVICE CLASS | | | |
|------------------|--------|---------------------------------|------|
| Material | Part # | Description | RoHS |
| ALUMINUM | -C | Black Anodized (Non-conductive) | |
| | -M | Electroless Nickel | |
| | -NF | Olive Drab Cadmium | |
| | -MT | Durmalon (Ni PTFE) | |
| | -ZN | Olive Drab Zinc Nickel | |
| | -ZNU | Black Zinc Nickel | |
| STAINLESS STEEL | -Z1 | Passivated | |
| | -ZL | Electrolytic Nickel | |

| 3. SIZE CODE | | | | |
|--------------|---------------------|----------------------|----------------------------|--------------|
| Size Code | UNEF-2B Thread Size | Cable Entry Diameter | Shell Size | |
| | | | Series 2M801, 2M803, 2M804 | Series 2M805 |
| 05 | .2500-32 UNEF | .11 | 5 | |
| 06 | .3125-32 UNEF | .17 | 6 | |
| 11 | .3750-32 UNEF | .17 | | 8 |
| 07 | .4375-28 UNEF | .23 | 7 | 9 |
| 08 | .5000-28 UNEF | .30 | 8 | 10 |
| 09 | .5625-24 UNEF | .30 | 9 | 11 |
| 10 | .6250-24 UNEF | .36 | 10 | 12 |
| 12 | .6875-24 UNEF | .42 | 12, 13 | |
| 13 | .7500-20 UNEF | .42 | | 15 |
| 14 | .9375-20 UNEF | .48 | 14, 15, 16, 17 | 18, 19 |
| 15 | .9375-20 UNEF | .61 | 14, 15, 16, 17 | 18, 19 |
| 17 | 1.1875-18 UNEF | .86 | 21 | 23 |

| MATERIALS | |
|-------------------------|--|
| Nut, Clamp, and Saddles | Aluminum Alloy 6061-T6 or 300 Series SST |
| Hardware | 300 Series Stainless Steel |

2M Strain Relief Clamp Dimensions

2M620MS064 and 2M620MS065

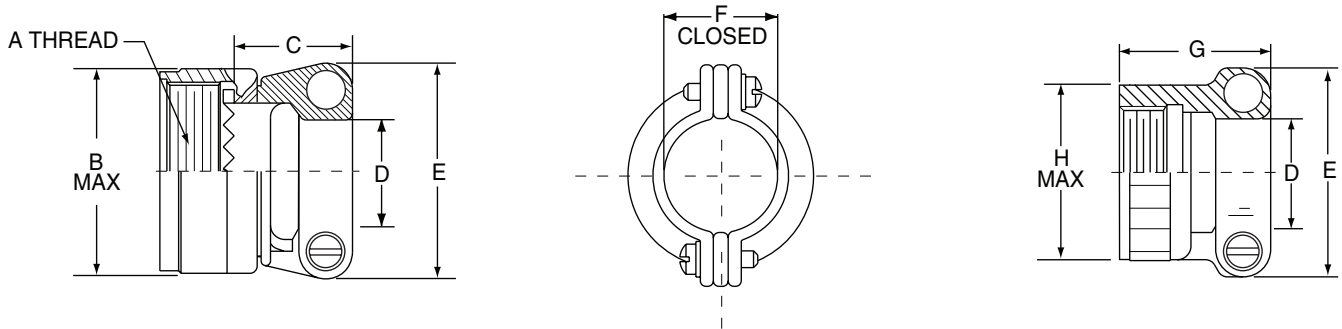

| Size Code | A Threads UNEF-2B | B Max. | | C Max. | | D DIA. | | E | | F | | G Max | | H Max. | |
|-----------|----------------------|--------|-------|--------|-------|---------------|---------------|---------------|---------------|---------------|---------------|-------|-------|--------|-------|
| | | in. | mm. | in. | mm. | in. ± .015 | mm. ± 0.38 | in. ± .015 | mm. ± 0.38 | in. ± .030 | mm. ± 0.76 | in. | mm. | in. | mm. |
| 05 | .2500-32 | .470 | 11.94 | .688 | 17.48 | .119 | 3.02 | .496 | 12.60 | .110 | 2.79 | .625 | 15.88 | .350 | 8.89 |
| 06 | .3125-32 | .530 | 13.46 | .688 | 17.48 | .182 | 4.62 | .582 | 14.78 | .170 | 4.32 | .625 | 15.88 | .415 | 10.54 |
| 11 | .3750-32 | .570 | 14.48 | .688 | 17.48 | .182 | 4.62 | .582 | 14.78 | .170 | 4.32 | .625 | 15.88 | .465 | 11.81 |
| 07 | .4375-28 | .637 | 16.18 | .688 | 17.48 | .244 | 6.20 | .656 | 16.66 | .230 | 5.08 | .688 | 17.48 | .530 | 13.46 |
| 08 | .5000-28 | .700 | 17.78 | .688 | 17.48 | .307 | 7.80 | .726 | 18.44 | .300 | 7.62 | .688 | 17.48 | .595 | 15.11 |
| 09 | .5625-24 | .758 | 19.25 | .750 | 19.05 | .307 | 7.80 | .726 | 18.44 | .300 | 7.62 | .750 | 19.05 | .650 | 16.51 |
| 10 | .6250-24 | .819 | 20.80 | .750 | 19.05 | .369 | 9.37 | .885 | 22.48 | .360 | 9.14 | .875 | 22.23 | .715 | 18.16 |
| 12 | .6875-24 | .896 | 22.76 | .750 | 19.05 | .432 | 10.97 | .952 | 24.18 | .420 | 10.67 | .875 | 22.23 | .785 | 19.94 |
| 13 | .7500-20 | .930 | 23.62 | .750 | 19.05 | .432 | 10.97 | .952 | 24.18 | .420 | 10.67 | .875 | 22.23 | .830 | 21.08 |
| 14 | .9375-20 | 1.137 | 28.88 | .750 | 19.05 | .494 | 12.55 | 1.018 | 25.86 | .480 | 12.19 | 1.000 | 25.40 | 1.020 | 25.91 |
| 15 | .9375-20 | 1.137 | 28.88 | .750 | 19.05 | .619 | 15.72 | 1.148 | 29.16 | .610 | 15.49 | 1.000 | 25.40 | 1.020 | 25.19 |
| 17 | 1.1875-18 | 1.397 | 35.48 | .750 | 19.05 | .869 | 22.07 | 1.400 | 35.56 | .860 | 21.84 | 1.125 | 28.58 | 1.280 | 32.51 |

2M Thread-On Micro Band Adapter

Ordering Information 2M440MS135, MK135 and ML135



| 1. | 2. | 3. | 4. | 5. | 6. |
|-------------|---------------|-----------|------------------|--------|--------------|
| PART NUMBER | SERVICE CLASS | SIZE CODE | CABLE ENTRY SIZE | LENGTH | BAND OPTIONS |
| 2M440MX135 | -M | 07 | 05 | -6 | K |

Omit for no band supplied
K adapter is supplied with
Micro Band shield termination
band, pre-coiled

| 1. PART NUMBER | |
|----------------|----------------|
| Part # | Description |
| 2M440MS135 | Straight Entry |
| 2M440MK135 | 45° Entry |
| 2M440ML135 | 90° Entry |

| 2. SERVICE CLASS | | | |
|------------------|--------|---------------------------------|------|
| Material | Part # | Description | RoHS |
| ALUMINUM | -C | Black Anodized (Non-conductive) | |
| | -M | Electroless Nickel | |
| | -NF | Olive Drab Cadmium | |
| | -MT | Durmalon (Ni PTFE) | |
| | -ZN | Olive Drab Zinc Nickel | |
| | -ZNU | Black Zinc Nickel | |
| STAINLESS STEEL | -Z1 | Passivated | |
| | -ZL | Electrolytic Nickel | |

| 3. SIZE CODE | |
|--------------|-----------|
| 05 | .2500-32 |
| 06 | .3125-32 |
| 11 | .3750-32 |
| 07 | .4375-28 |
| 08 | .5000-28 |
| 09 | .5625-24 |
| 10 | .6250-24 |
| 12 | .6875-24 |
| 13 | .7500-20 |
| 14 | .9375-20 |
| 17 | 1.1875-18 |

| 4. CABLE ENTRY SIZE | | |
|---------------------|------|-------|
| 02 | .125 | 05-17 |
| 03 | .188 | 05-17 |
| 04 | .250 | 06-17 |
| 05 | .312 | 07-17 |
| 06 | .375 | 07-17 |
| 07 | .438 | 08-17 |
| 08 | .500 | 09-17 |
| 09 | .562 | 10-17 |
| 10 | .625 | 12-17 |
| 11 | .688 | 14-17 |
| 12 | .750 | 14-17 |
| 13 | .812 | 14-17 |
| 14 | .875 | 14-17 |

| 5. LENGTH | |
|-----------------------------------|-----------------|
| Straight Entry 2M440MS135 Only | |
| Length Code | Length (inches) |
| -6 | .750 |
| -7 | .875 |
| -8 | 1.000 |
| -9 | 1.125 |
| -10 | 1.250 |
| -11 | 1.375 |
| -12 | 1.500 |
| -13 | 1.625 |
| -14 | 1.750 |
| -15 | 1.875 |
| -16 | 2.000 |
| -17 | 2.125 |
| -18 | 2.250 |
| -19 | 2.375 |
| -20 | 2.500 |

Specify Length in increments of .125 inches (3.18 mm.)

| SHELL SIZE | | | | | |
|-------------------|-----------|--------------|--------------|--------------|--------------|
| Accessory Thread | Size Code | Series 2M801 | Series 2M803 | Series 2M804 | Series 2M805 |
| .2500-32 UNEF-2B | 05 | 5 | 5 | 5 | |
| .3125-32 UNEF-2B | 06 | 6 | 6 | 6 | |
| .3750-32 UNEF-2B | 11 | | | | 8 |
| .4375-28 UNEF-2B | 07 | 7 | 7 | 7 | 9 |
| .5000-28 UNEF-2B | 08 | 8 | 8 | 8 | 10 |
| .5625-24 UNEF-2B | 09 | 9 | 9 | 9 | 11 |
| .6250-24 UNEF-2B | 10 | 10 | 10 | 10 | 12 |
| .6875-24 UNEF-2B | 12 | 13 | 12 | 12 | |
| .7500-20 UNEF-2B | 13 | | | | 15 |
| .9375-20 UNEF-2B | 14 | 16,17 | 14, 15 | 14, 15 | 18, 19 |
| 1.1875-18 UNEF-2B | 17 | 21 | | | 23 |

| MATERIALS | |
|--------------|----------------------------------|
| Nut, Adapter | Aluminum Alloy or 300 Series SST |
| Band | 300 Series SST |
| O-Ring | Silicone Elastomer |

Accessories
Contacts Tools

J

2M Thread-On Micro Band Adapter

2M440MS135, MK135 and ML135

| Size Code | A Threads UNEF-2B | B Max | | C Max. | | D Max. | | E Max. | | F Max. | |
|-----------|-------------------------|-------|-------|--------|-------|--------|-------|--------|-------|--------|-------|
| | | in. | mm. | in. | mm. | in. | mm. | in. | mm. | in. | mm. |
| 05 | .2500-32 | .470 | 11.94 | .530 | 13.46 | .660 | 16.76 | .630 | 16.00 | .780 | 19.81 |
| 06 | .3125-32 | .530 | 13.46 | .550 | 13.97 | .670 | 17.02 | .660 | 16.76 | .790 | 20.27 |
| 11 | .3750-32 | .570 | 14.48 | .560 | 14.22 | .680 | 17.27 | .680 | 17.27 | .810 | 20.57 |
| 07 | .4375-28 | .637 | 16.18 | .570 | 14.48 | .690 | 17.53 | .700 | 17.48 | .830 | 21.08 |
| 08 | .5000-28 | .700 | 17.78 | .580 | 14.73 | .700 | 17.78 | .740 | 18.80 | .860 | 21.84 |
| 09 | .5625-24 | .758 | 19.25 | .590 | 14.99 | .710 | 18.03 | .770 | 19.56 | .890 | 22.61 |
| 10 | .6250-24 | .819 | 20.80 | .610 | 15.49 | .730 | 18.54 | .800 | 20.32 | .920 | 23.37 |
| 12 | .6875-24 | .896 | 22.76 | .640 | 16.26 | .750 | 19.05 | .840 | 21.34 | .970 | 24.64 |
| 13 | .7500-20 | .930 | 23.62 | .660 | 16.76 | .770 | 19.56 | .880 | 22.35 | 1.020 | 25.91 |
| 14 | .9375-20 | 1.137 | 28.88 | .690 | 17.53 | .800 | 20.32 | .950 | 24.13 | 1.090 | 27.69 |
| 17 | 1.1875-18 | 1.387 | 35.23 | .720 | 18.29 | .830 | 21.08 | 1.010 | 25.65 | 1.160 | 29.46 |

STRAIGHT ENTRY ROTATABLE COUPLING 2M440MS135

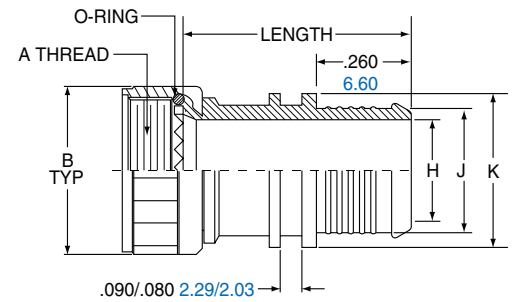

| CABLE ENTRY | | | | | | | |
|------------------|---------------|---------------|---------------|---------------|---------------|---------------|---------------------|
| Cable Entry Code | H Dia. | | J Dia. | | K Dia. | | Use With Size Codes |
| | in. ± .015 | mm. ± 0.38 | in. ± .015 | mm. ± 0.38 | in. ± .015 | mm. ± 0.38 | |
| 02 | .125 | 3.18 | .164 | 4.17 | .266 | 6.76 | 05-14 |
| 03 | .188 | 4.78 | .227 | 5.77 | .329 | 8.36 | 05-14 |
| 04 | .250 | 6.35 | .289 | 7.34 | .391 | 9.93 | 06-14 |
| 05 | .312 | 7.92 | .351 | 8.92 | .453 | 11.51 | 07-14 |
| 06 | .375 | 9.53 | .414 | 10.52 | .516 | 13.11 | 07-14 |
| 07 | .438 | 11.13 | .477 | 12.12 | .579 | 14.71 | 08-14 |
| 08 | .500 | 12.70 | .539 | 13.69 | .641 | 16.28 | 09-14 |
| 09 | .562 | 14.27 | .601 | 15.27 | .703 | 17.86 | 10-14 |
| 10 | .625 | 15.88 | .664 | 16.87 | .766 | 19.46 | 12-14 |
| 11 | .688 | 17.48 | .727 | 18.47 | .829 | 21.06 | 14 |
| 12 | .750 | 19.05 | .789 | 20.04 | .891 | 22.63 | 14 |
| 13 | .812 | 20.62 | .851 | 21.62 | .953 | 24.21 | 14 |
| 14 | .875 | 22.23 | .914 | 23.22 | 1.016 | 25.81 | 14 |

45° ENTRY ROTATABLE COUPLING 2M440MK135

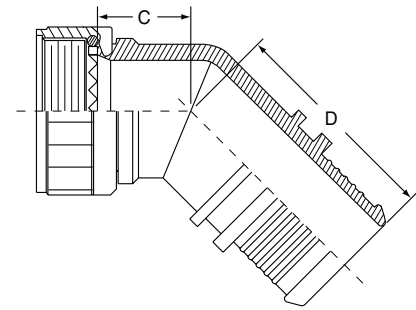

| CONNECTOR SHELL SIZE | | | |
|----------------------|-------------------|----------------------------|--------------|
| Size Code | A Threads | Shell Size | |
| | | Series 2M801, 2M803, 2M804 | Series 2M805 |
| 05 | .2500-32 UNEF-2B | 5 | |
| 06 | .3125-32 UNEF-2B | 6 | |
| 11 | .3750-32 UNEF-2B | | 8 |
| 07 | .4375-28 UNEF-2B | 7 | 9 |
| 08 | .5000-28 UNEF-2B | 8 | 10 |
| 09 | .5625-24 UNEF-2B | 9 | 11 |
| 10 | .6250-24 UNEF-2B | 10 | 12 |
| 12 | .6875-24 UNEF-2B | 12, 13 | |
| 13 | .7500-20 UNEF-2B | | 15 |
| 14 | .9375-20 UNEF-2B | 14, 15, 16, 17 | 18, 19 |
| 17 | 1.1875-18 UNEF-2B | 21 | 23 |

90° ENTRY ROTATABLE COUPLING 2M440ML135

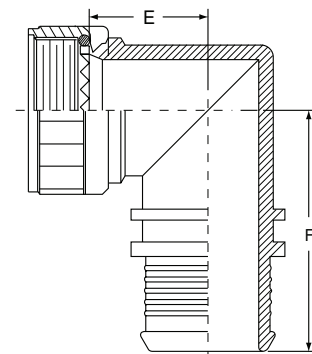

2M Low-Profile Micro Band Adapter Order Info

2M440MS134



| 1. | 2. | 3. | 4. | 5. | 6. |
|-------------|---------------|-----------|------------------|--------|--------------|
| PART NUMBER | SERVICE CLASS | SIZE CODE | CABLE ENTRY SIZE | LENGTH | BAND OPTIONS |
| 2M440MS134 | -M | 07 | 05 | -6 | K |

Omit for no band supplied
K adapter is supplied with
Micro Band shield
termination band, pre-coiled

| 1. PART NUMBER | |
|----------------|----------------|
| Part # | Description |
| 2M440MS134 | Straight Entry |

| 2. SERVICE CLASS | | | |
|------------------|--------|---------------------------------|------|
| Material | Part # | Description | RoHS |
| ALUMINUM | -C | Black Anodized (Non-conductive) | |
| | -M | Electroless Nickel | |
| | -NF | Olive Drab Cadmium | |
| | -MT | Durmalon (Ni PTFE) | |
| | -ZN | Olive Drab Zinc Nickel | |
| | -ZNU | Black Zinc Nickel | |
| STAINLESS STEEL | -Z1 | Passivated | |
| | -ZL | Electrolytic Nickel | |

| 3. SIZE CODE | |
|--------------|-----------|
| 05 | .2500-32 |
| 06 | .3125-32 |
| 11 | .3750-32 |
| 07 | .4375-28 |
| 08 | .5000-28 |
| 09 | .5625-24 |
| 10 | .6250-24 |
| 12 | .6875-24 |
| 13 | .7500-20 |
| 14 | .9375-20 |
| 17 | 1.1875-18 |

| 4. CABLE ENTRY SIZE | | |
|---------------------|------|-----------|
| 01 | .094 | 05-06, 11 |
| 02 | .125 | 05-07, 11 |
| 03 | .175 | 05-08, 11 |
| 04 | .234 | 06-08 |
| 05 | .272 | 07-09 |
| 06 | .312 | 07-10 |
| 07 | .375 | 08-13 |
| 08 | .438 | 09-13 |
| 09 | .500 | 10-13 |
| 10 | .562 | 12-14, 17 |
| 11 | .625 | 14, 17 |
| 12 | .688 | 14, 17 |
| 13 | .750 | 14, 17 |
| 14 | .812 | 14, 17 |

| 5. LENGTH | |
|-----------------------------------|-----------------|
| Straight Entry 2M440MS135 Only | |
| Length Code | Length (inches) |
| -6 | .750 |
| -7 | .875 |
| -8 | 1.000 |
| -9 | 1.125 |
| -10 | 1.250 |
| -11 | 1.375 |
| -12 | 1.500 |
| -13 | 1.625 |
| -14 | 1.750 |
| -15 | 1.875 |
| -16 | 2.000 |
| -17 | 2.125 |
| -18 | 2.250 |
| -19 | 2.375 |
| -20 | 2.500 |

Specify Length in increments of .125 inches (3.18 mm.)

| SHELL SIZE | | | | | |
|-------------------|-----------|--------------|--------------|--------------|--------------|
| Accessory Thread | Size Code | Series 2M801 | Series 2M803 | Series 2M804 | Series 2M805 |
| .2500-32 UNEF-2B | 05 | 5 | 5 | 5 | |
| .3125-32 UNEF-2B | 06 | 6 | 6 | 6 | |
| .3750-32 UNEF-2B | 11 | | | | 8 |
| .4375-28 UNEF-2B | 07 | 7 | 7 | 7 | 9 |
| .5000-28 UNEF-2B | 08 | 8 | 8 | 8 | 10 |
| .5625-24 UNEF-2B | 09 | 9 | 9 | 9 | 11 |
| .6250-24 UNEF-2B | 10 | 10 | 10 | 10 | 12 |
| .6875-24 UNEF-2B | 12 | 13 | 12 | 12 | |
| .7500-20 UNEF-2B | 13 | | | | 15 |
| .9375-20 UNEF-2B | 14 | 16,17 | 14, 15 | 14, 15 | 18, 19 |
| 1.1875-18 UNEF-2B | 17 | 21 | | | 23 |

| MATERIALS | |
|--------------|----------------------------------|
| Nut, Adapter | Aluminum Alloy or 300 Series SST |
| Band | 300 Series SST |
| O-Ring | Silicone Elastomer |

Accessories
Contacts Tools

J

2M Low-Profile Micro-Band Adapter Dimensions

2M440MS134

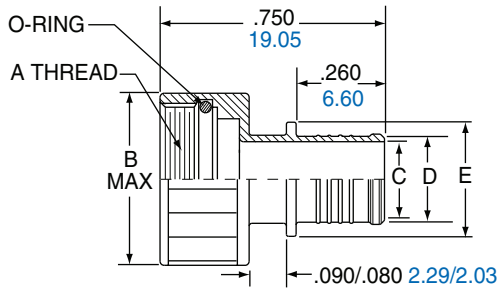

| CONNECTOR SHELL SIZE | | | |
|----------------------|-------------------|--------|-------|
| Size Code | A Threads | B Max. | |
| | | in. | mm. |
| 05 | .2500-32 UNEF-2B | .350 | 8.89 |
| 06 | .3125-32 UNEF-2B | .415 | 10.54 |
| 11 | .3750-32 UNEF-2B | .465 | 11.81 |
| 07 | .4375-28 UNEF-2B | .530 | 13.46 |
| 08 | .5000-28 UNEF-2B | .595 | 15.11 |
| 09 | .5625-24 UNEF-2B | .650 | 16.51 |
| 10 | .6250-24 UNEF-2B | .715 | 18.16 |
| 12 | .6875-24 UNEF-2B | .785 | 19.94 |
| 13 | .7500-20 UNEF-2B | .830 | 21.08 |
| 14 | .9375-20 UNEF-2B | 1.020 | 25.91 |
| 17 | 1.1875-18 UNEF-2B | 1.280 | 32.51 |

| Cable Entry Code | CABLE ENTRY | | | | | | Use With Size Codes |
|------------------|-------------|------------|------------|------------|------------|------------|---------------------|
| | C Dia. | | D Dia. | | E Dia. | | |
| | in. ± .015 | mm. ± 0.38 | in. ± .015 | mm. ± 0.38 | in. ± .015 | mm. ± 0.38 | |
| 01 | .094 | 2.39 | .133 | 3.38 | .235 | 5.97 | 05-06 |
| 02 | .125 | 3.18 | .164 | 4.17 | .266 | 6.76 | 05-07 |
| 03 | .172 | 4.37 | .211 | 5.36 | .313 | 7.95 | 05-08 |
| 04 | .234 | 5.94 | .273 | 6.93 | .375 | 9.53 | 06-08 |
| 05 | .272 | 6.91 | .311 | 7.90 | .413 | 10.49 | 07-09 |
| 06 | .312 | 7.92 | .351 | 8.92 | .453 | 11.51 | 07-10 |
| 07 | .375 | 9.53 | .414 | 10.52 | .516 | 13.11 | 08-12 |
| 08 | .438 | 11.13 | .477 | 12.12 | .579 | 14.71 | 09-12 |
| 09 | .500 | 12.70 | .539 | 13.69 | .641 | 16.28 | 10-12 |
| 10 | .562 | 14.27 | .601 | 15.27 | .703 | 17.88 | 12-14 |
| 11 | .625 | 15.88 | .664 | 16.87 | .766 | 19.46 | 14 |
| 12 | .688 | 17.48 | .727 | 18.47 | .829 | 21.06 | 14 |
| 13 | .750 | 19.05 | .789 | 20.04 | .891 | 22.63 | 14 |
| 14 | .812 | 20.62 | .851 | 21.62 | .953 | 24.21 | 14 |

| Size Code | A Threads | CONNECTOR SHELL SIZE | |
|-----------|-------------------|----------------------------|--------------|
| | | Shell Size | |
| | | Series 2M801, 2M803, 2M804 | Series 2M805 |
| 05 | .2500-32 UNEF-2B | 5 | |
| 06 | .3125-32 UNEF-2B | 6 | |
| 11 | .3750-32 UNEF-2B | | 8 |
| 07 | .4375-28 UNEF-2B | 7 | 9 |
| 08 | .5000-28 UNEF-2B | 8 | 10 |
| 09 | .5625-24 UNEF-2B | 9 | 11 |
| 10 | .6250-24 UNEF-2B | 10 | 12 |
| 12 | .6875-24 UNEF-2B | 12, 13 | |
| 13 | .7500-20 UNEF-2B | | 15 |
| 14 | .9375-20 UNEF-2B | 14, 15, 16, 17 | 18, 19 |
| 17 | 1.1875-18 UNEF-2B | 21 | 23 |

2M Environmental Backshell Ordering Info

2M370MS37, MS038, MB038 and MA038



| 1. | 2. | 3. | 4. | 5. | 6. |
|-------------|---------------|-----------|------------------|--------|---------|
| PART NUMBER | SERVICE CLASS | SIZE CODE | CABLE ENTRY SIZE | LENGTH | OPTIONS |
| 2M370MS038 | -M | 07 | 05 | -6 | N |

Omit for screw clamp with saddle bars
 N Optional Compression Nut,
 Low Profile

| 1. PART NUMBER | |
|----------------|-----------------------------------|
| Part # | Description |
| 2M370MS038 | Straight Entry Rotatable Coupling |
| 2M370MS037 | Straight Entry, Direct Coupling |
| 2M370MB038 | 45° Entry |
| 2M370MA038 | 90° Entry |

| 2. SERVICE CLASS | | | |
|------------------|-----------------|---------------------------------|------------|
| Material | Part # | Description | RoHS |
| ALUMINUM | -C | Black Anodized (Non-conductive) | |
| | -M | Electroless Nickel | |
| | -NF | Olive Drab Cadmium | |
| | -MT | Durmalon (Ni PTFE) | |
| | -ZN | Olive Drab Zinc Nickel | |
| | -ZNU | Black Zinc Nickel | |
| | STAINLESS STEEL | -Z1 | Passivated |
| -ZL | | Electrolytic Nickel | |

| 3. SIZE CODE | |
|--------------|-----------|
| 05 | .2500-32 |
| 06 | .3125-32 |
| 11 | .3750-32 |
| 07 | .4375-28 |
| 08 | .5000-28 |
| 09 | .5625-24 |
| 10 | .6250-24 |
| 12 | .6875-24 |
| 13 | .7500-20 |
| 14 | .9375-20 |
| 17 | 1.1875-18 |

| 4. CABLE ENTRY SIZE | | |
|---------------------|------|------|
| Code | Max. | Min. |
| 01 | .109 | .031 |
| 02 | .172 | .078 |
| 03 | .234 | .140 |
| 04 | .297 | .203 |
| 05 | .359 | .265 |
| 06 | .422 | .328 |
| 07 | .484 | .390 |
| 08 | .547 | .463 |
| 09 | .609 | .515 |

| 5. LENGTH | |
|------------------------------|-----------------|
| Straight Entry 2M440MS. Only | |
| Length Code | Length (inches) |
| -5 | .625 |
| -6 | .750 |
| -7 | .875 |
| -8 | 1.000 |
| -9 | 1.125 |
| -10 | 1.250 |
| -11 | 1.375 |
| -12 | 1.500 |
| -13 | 1.625 |
| -14 | 1.750 |
| -15 | 1.875 |
| -16 | 2.000 |
| -17 | 2.125 |
| -18 | 2.250 |
| -19 | 2.375 |
| -20 | 2.500 |

Specify Length in increments of .125 inches (3.18 mm.)

| SHELL SIZE | | | | | |
|-------------------|-----------|--------------|--------------|--------------|--------------|
| Accessory Thread | Size Code | Series 2M801 | Series 2M803 | Series 2M804 | Series 2M805 |
| .2500-32 UNEF-2B | 05 | 5 | 5 | 5 | |
| .3125-32 UNEF-2B | 06 | 6 | 6 | 6 | |
| .3750-32 UNEF-2B | 11 | | | | 8 |
| .4375-28 UNEF-2B | 07 | 7 | 7 | 7 | 9 |
| .5000-28 UNEF-2B | 08 | 8 | 8 | 8 | 10 |
| .5625-24 UNEF-2B | 09 | 9 | 9 | 9 | 11 |
| .6250-24 UNEF-2B | 10 | 10 | 10 | 10 | 12 |
| .6875-24 UNEF-2B | 12 | 13 | 12 | 12 | |
| .7500-20 UNEF-2B | 13 | | | | 15 |
| .9375-20 UNEF-2B | 14 | 16,17 | 14, 15 | 14, 15 | 18, 19 |
| 1.1875-18 UNEF-2B | 17 | 21 | | | 23 |

| MATERIALS | |
|---------------------------------|--|
| Adapter, Clamp, Nut and Saddles | Aluminum Alloy 6061-T6 or 300 Series Stainless Steel |
| O-Rings | Silicone Rubber |
| Hardware | 300 Series Stainless Steel |

Accessories
Contacts Tools

J

2M Environmental Backshell

2M370MS037, MS038, MB038 and MA038

STRAIGHT ENTRY
ROTATABLE COUPLING
2M370MS038

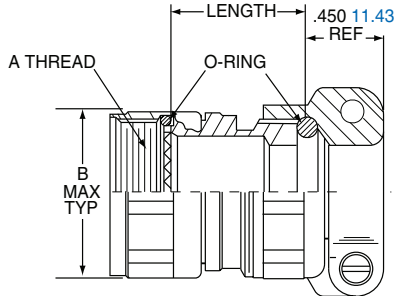

STRAIGHT ENTRY
DIRECT COUPLING
2M370MS037

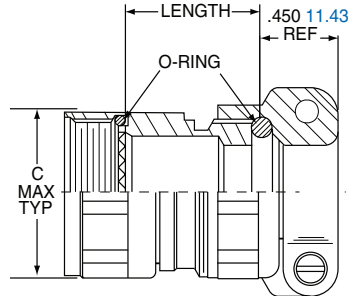

CLAMP STYLE N
COMPRESSION NUT

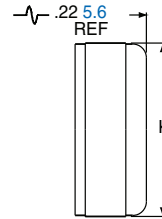

SADDLE CLAMP

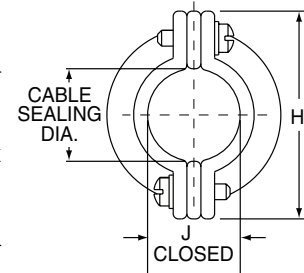

45° ENTRY
ROTATABLE COUPLING
2M370MB038

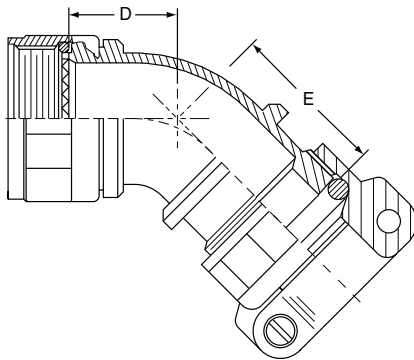

90° ENTRY
ROTATABLE COUPLING
2M370MA038

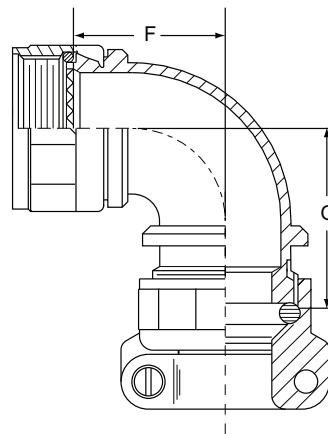

| Size Code | A Threads UNEF-2B | B Max. | | C Max. | |
|-----------|-------------------|--------|-------|--------|-------|
| | | in. | mm. | in. | mm. |
| 05 | .2500-32 | .470 | 11.94 | .350 | 8.89 |
| 06 | .3125-32 | .530 | 13.46 | .415 | 10.54 |
| 11 | .3750-32 | .570 | 14.48 | .465 | 11.68 |
| 07 | .4375-28 | .637 | 16.18 | .530 | 13.46 |
| 08 | .5000-28 | .700 | 17.78 | .595 | 15.11 |
| 09 | .5625-24 | .758 | 19.25 | .650 | 16.51 |
| 10 | .6250-24 | .819 | 20.80 | .715 | 18.16 |
| 12 | .6875-24 | .896 | 22.76 | .785 | 19.94 |
| 13 | .7500-20 | .930 | 23.62 | .830 | 21.08 |
| 14 | .9375-20 | 1.137 | 28.88 | 1.020 | 25.91 |
| 17 | 1.1875-18 | 1.280 | 32.51 | 1.280 | 32.51 |

| CABLE ENTRY | | | | | | | | | | | | | | | | |
|------------------|--------------------|------|--------|-------|--------|-------|--------|-------|--------|-------|--------|--------|--------|--------|--------|--------|
| Cable Entry Code | Cable Sealing Dia. | | D Max. | | E Max. | | F Max. | | G Max. | | H Dia. | | J Dia. | | K Dia. | |
| | Max. | Min. | in. | mm. | in. | mm. | in. | mm. | in. | mm. | ± .015 | ± 0.38 | ± .030 | ± 0.76 | ± .015 | ± 0.38 |
| | 01 | .109 | .031 | .603 | 15.32 | .581 | 14.67 | .724 | 18.39 | .702 | 17.83 | .496 | 12.60 | .110 | 2.79 | .398 |
| 02 | .172 | .078 | .603 | 15.32 | .581 | 14.67 | .724 | 18.39 | .702 | 17.83 | .582 | 14.78 | .170 | 4.32 | .460 | 11.68 |
| 03 | .234 | .140 | .603 | 15.32 | .581 | 14.67 | .724 | 18.39 | .702 | 17.83 | .656 | 16.66 | .230 | 5.84 | .523 | 13.28 |
| 04 | .297 | .203 | .629 | 15.98 | .607 | 15.42 | .786 | 19.96 | .764 | 19.41 | .726 | 18.44 | .300 | 7.62 | .585 | 14.86 |
| 05 | .359 | .265 | .629 | 15.98 | .607 | 15.42 | .786 | 19.96 | .764 | 19.41 | .885 | 22.48 | .360 | 9.14 | .647 | 16.43 |
| 06 | .422 | .328 | .655 | 16.64 | .633 | 16.00 | .848 | 21.54 | .826 | 20.98 | .952 | 24.18 | .420 | 10.67 | .710 | 18.03 |
| 07 | .484 | .390 | .655 | 16.64 | .633 | 16.00 | .848 | 21.54 | .826 | 20.98 | 1.018 | 25.86 | .480 | 12.19 | .773 | 19.63 |
| 08 | .547 | .453 | .707 | 17.96 | .685 | 17.40 | .911 | 23.14 | .889 | 22.68 | 1.084 | 27.53 | .550 | 13.97 | .835 | 21.21 |
| 09 | .609 | .515 | .707 | 17.96 | .685 | 17.40 | .911 | 23.14 | .889 | 22.58 | 1.148 | 29.16 | .610 | 15.49 | .897 | 22.76 |

2M EMI Backshell Ordering Information

2M380MS137, MS135, MB137 and MA137



| 1. | 2. | 3. | 4. | 5. | 6. |
|-------------|---------------|-----------|------------------|--------|---------|
| PART NUMBER | SERVICE CLASS | SIZE CODE | CABLE ENTRY SIZE | LENGTH | OPTIONS |
| 2M380MS135 | -M | 07 | 05 | -6 | N |

Omit for screw clamp with saddle bars
N Optional Compression Nut, Low Profile

| 1. PART NUMBER | |
|----------------|-----------------------------------|
| Part # | Description |
| 2M380MS137 | Straight Entry Rotatable Coupling |
| 2M380MS135 | Straight Entry, Direct Coupling |
| 2M380MB137 | 45° Entry |
| 2M380MA137 | 90° Entry |

| 2. SERVICE CLASS | | | |
|------------------|--------|---------------------------------|------|
| Material | Part # | Description | RoHS |
| ALUMINUM | -C | Black Anodized (Non-conductive) | |
| | -M | Electroless Nickel | |
| | -NF | Olive Drab Cadmium | |
| | -MT | Durmalon (Ni PTFE) | |
| | -ZN | Olive Drab Zinc Nickel | |
| | -ZNU | Black Zinc Nickel | |
| STAINLESS STEEL | -Z1 | Passivated | |
| | -ZL | Electrolytic Nickel | |

| 3. SIZE CODE | |
|--------------|-----------|
| 05 | .2500-32 |
| 06 | .3125-32 |
| 11 | .3750-32 |
| 07 | .4375-28 |
| 08 | .5000-28 |
| 09 | .5625-24 |
| 10 | .6250-24 |
| 12 | .6875-24 |
| 13 | .7500-20 |
| 14 | .9375-20 |
| 17 | 1.1875-18 |

| 4. CABLE ENTRY SIZE | |
|---------------------|--------------------------------|
| Code | Saddle Clamp Dia. Fully Closed |
| 01 | .109 |
| 02 | .172 |
| 03 | .234 |
| 04 | .297 |
| 05 | .359 |
| 06 | .422 |
| 07 | .484 |
| 08 | .547 |
| 09 | .609 |

| 5. LENGTH | |
|-----------------------------|-----------------|
| Straight Entry 2M380MS Only | |
| Length Code | Length (inches) |
| -5 | .625 |
| -6 | .750 |
| -7 | .875 |
| -8 | 1.000 |
| -9 | 1.125 |
| -10 | 1.250 |
| -11 | 1.375 |
| -12 | 1.500 |
| -13 | 1.625 |
| -14 | 1.750 |
| -15 | 1.875 |
| -16 | 2.000 |
| -17 | 2.125 |
| -18 | 2.250 |
| -19 | 2.375 |
| -20 | 2.500 |

Specify Length in increments of .125 inches (3.18 mm.)

| SHELL SIZE | | | | | | | |
|-------------------|-----------|--------------|--------------|--------------|--------------|--|--|
| Accessory Thread | Size Code | Series 2M801 | Series 2M803 | Series 2M804 | Series 2M805 | | |
| .2500-32 UNEF-2B | 05 | 5 | 5 | 5 | | | |
| .3125-32 UNEF-2B | 06 | 6 | 6 | 6 | | | |
| .3750-32 UNEF-2B | 11 | | | | 8 | | |
| .4375-28 UNEF-2B | 07 | 7 | 7 | 7 | 9 | | |
| .5000-28 UNEF-2B | 08 | 8 | 8 | 8 | 10 | | |
| .5625-24 UNEF-2B | 09 | 9 | 9 | 9 | 11 | | |
| .6250-24 UNEF-2B | 10 | 10 | 10 | 10 | 12 | | |
| .6875-24 UNEF-2B | 12 | 13 | 12 | 12 | | | |
| .7500-20 UNEF-2B | 13 | | | | 15 | | |
| .9375-20 UNEF-2B | 14 | 16,17 | 14, 15 | 14, 15 | 18, 19 | | |
| 1.1875-18 UNEF-2B | 17 | 21 | | | 23 | | |

| MATERIALS | |
|---------------------------------|--|
| Adapter, Clamp, Nut and Saddles | Aluminum Alloy 6061-T6 or 300 Series Stainless Steel |
| O-Rings | Silicone Rubber |
| Hardware | 300 Series Stainless Steel |

Accessories
Contacts Tools

2M EMI Backshell

2M380MS137, MS135, MB138 and MA138

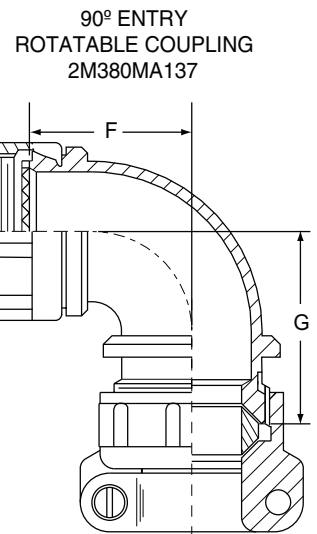
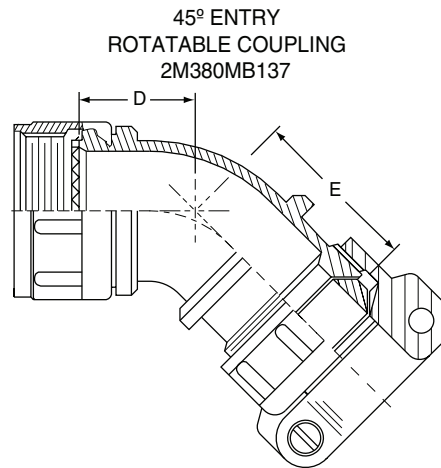
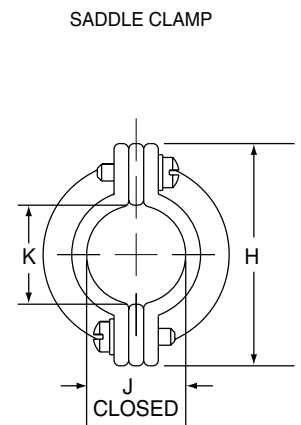
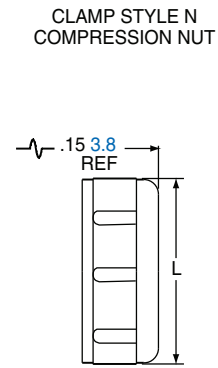
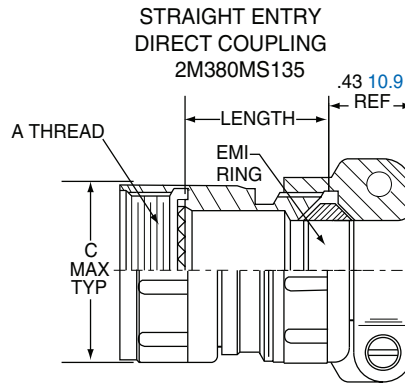
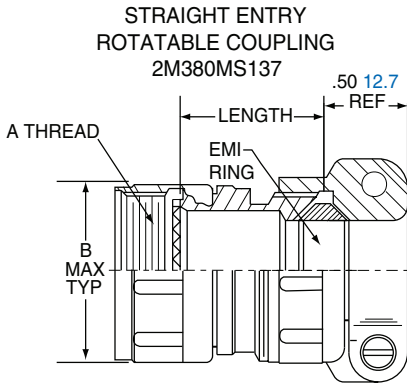

| Size Code | A Threads | B Max. | | C Max. | |
|-----------|-------------------|--------|-------|--------|-------|
| | | in. | mm. | in. | mm. |
| 05 | .2500-32 UNEF-2B | .470 | 11.94 | .350 | 8.89 |
| 06 | .3125-32 UNEF-2B | .530 | 13.46 | .415 | 10.54 |
| 11 | .3750-32 UNEF-2B | .570 | 14.48 | .465 | 11.68 |
| 07 | .4375-28 UNEF-2B | .637 | 16.18 | .530 | 13.46 |
| 08 | .5000-28 UNEF-2B | .700 | 17.78 | .595 | 15.11 |
| 09 | .5625-24 UNEF-2B | .758 | 19.25 | .650 | 16.51 |
| 10 | .6250-24 UNEF-2B | .819 | 20.80 | .715 | 18.16 |
| 12 | .6875-24 UNEF-2B | .896 | 22.76 | .785 | 19.94 |
| 13 | .7500-20 UNEF-2B | .930 | 23.62 | .830 | 21.08 |
| 14 | .9375-20 UNEF-2B | 1.137 | 28.88 | 1.020 | 25.91 |
| 17 | 1.1875-18 UNEF-2B | 1.387 | 35.23 | 1.280 | 32.51 |

| Cable Entry Code | CABLE ENTRY | | | | | | | | | | | | | | | |
|------------------|-------------|-------|--------|-------|--------|-------|--------|-------|------------|------------|---------------|------------|------------|------------|------------|------------|
| | D Max. | | E Max. | | F Max. | | G Max. | | H | | J Dia. Closed | | K Dia. | | L Dia. | |
| | in. | mm. | in. | mm. | in. | mm. | in. | mm. | in. ± .015 | mm. ± 0.38 | in. ± .030 | mm. ± 0.76 | in. ± .015 | mm. ± 0.38 | in. ± .015 | mm. ± 0.38 |
| 01 | .603 | 15.32 | .581 | 14.67 | .724 | 18.39 | .702 | 17.83 | .496 | 12.60 | .110 | 2.79 | .119 | 3.02 | .398 | 10.11 |
| 02 | .603 | 15.32 | .581 | 14.67 | .724 | 18.39 | .702 | 17.83 | .582 | 14.78 | .170 | 4.32 | .182 | 4.62 | .460 | 11.68 |
| 03 | .603 | 15.32 | .581 | 14.67 | .724 | 18.39 | .702 | 17.83 | .656 | 16.66 | .230 | 5.84 | .244 | 6.20 | .523 | 13.28 |
| 04 | .629 | 15.98 | .607 | 15.42 | .786 | 19.96 | .764 | 19.41 | .726 | 18.44 | .300 | 7.62 | .307 | 7.80 | .585 | 14.86 |
| 05 | .629 | 15.98 | .607 | 15.42 | .786 | 19.96 | .764 | 19.41 | .885 | 22.48 | .360 | 9.14 | .369 | 9.37 | .647 | 16.43 |
| 06 | .655 | 16.64 | .633 | 16.00 | .848 | 21.54 | .826 | 20.98 | .952 | 24.18 | .420 | 10.67 | .432 | 10.97 | .710 | 18.03 |
| 07 | .655 | 16.64 | .633 | 16.00 | .848 | 21.54 | .826 | 20.98 | 1.018 | 25.86 | .480 | 12.19 | .494 | 12.55 | .773 | 19.63 |
| 08 | .707 | 17.96 | .685 | 17.40 | .911 | 23.14 | .889 | 22.68 | 1.084 | 27.53 | .550 | 13.97 | .557 | 14.15 | .835 | 21.21 |
| 09 | .707 | 17.96 | .685 | 17.40 | .911 | 23.14 | .889 | 22.58 | 1.148 | 29.16 | .610 | 15.49 | .619 | 15.72 | .897 | 22.76 |

2M Environmental EMI Backshell Ordering Info

2M390MS077, MS076, 2M390MB077 and 2M390MA077



| 1. | 2. | 3. | 4. | 5. | 6. |
|-------------|---------------|-----------|------------------|--------|---------|
| PART NUMBER | SERVICE CLASS | SIZE CODE | CABLE ENTRY SIZE | LENGTH | OPTIONS |
| 2M390MS076 | -M | 07 | 05 | -6 | N |

Omit for screw clamp with saddle bars
N Optional Compression Nut, Low Profile

| 1. PART NUMBER | |
|----------------|-----------------------------------|
| Part # | Description |
| 2M390MS077 | Straight Entry Rotatable Coupling |
| 2M390MS076 | Straight Entry, Direct Coupling |
| 2M390MB077 | 45° Entry Rotatable Coupling |
| 2M390MA077 | 90° Entry Rotatable Coupling |

| 2. SERVICE CLASS | |
|------------------|------------------------------------|
| Material | Part # Description RoHS |
| ALUMINUM | -C Black Anodized (Non-conductive) |
| | -M Electroless Nickel |
| | -NF Olive Drab Cadmium |
| | -MT Durmalon (Ni PTFE) |
| | -ZN Olive Drab Zinc Nickel |
| | -ZNU Black Zinc Nickel |
| STAINLESS STEEL | -Z1 Passivated |
| | -ZL Electrolytic Nickel |

| 3. SIZE CODE | |
|--------------|-----------|
| Code | Range |
| 05 | .2500-32 |
| 06 | .3125-32 |
| 11 | .3750-32 |
| 07 | .4375-28 |
| 08 | .5000-28 |
| 09 | .5625-24 |
| 10 | .6250-24 |
| 12 | .6875-24 |
| 13 | .7500-20 |
| 14 | .9375-20 |
| 17 | 1.1875-18 |

| 4. CABLE ENTRY SIZE | | |
|---------------------|------|------|
| Code | Max. | Min. |
| 01 | .109 | .031 |
| 02 | .172 | .078 |
| 03 | .234 | .140 |
| 04 | .297 | .203 |
| 05 | .359 | .265 |
| 06 | .422 | .328 |
| 07 | .484 | .390 |
| 08 | .547 | .463 |
| 09 | .609 | .515 |
| 10 | .672 | .578 |
| 11 | .734 | .640 |

| 5. LENGTH | |
|-----------------------------|-----------------|
| Straight Entry 2M380MS Only | |
| Length Code | Length (inches) |
| -5 | .625 |
| -6 | .750 |
| -7 | .875 |
| -8 | 1.000 |
| -9 | 1.125 |
| -10 | 1.250 |
| -11 | 1.375 |
| -12 | 1.500 |
| -13 | 1.625 |
| -14 | 1.750 |
| -15 | 1.875 |
| -16 | 2.000 |
| -17 | 2.125 |
| -18 | 2.250 |
| -19 | 2.375 |
| -20 | 2.500 |

Specify Length in increments of .125 inches (3.18 mm.)

| SHELL SIZE | | | | | |
|-------------------|-----------|--------------|--------------|--------------|--------------|
| Accessory Thread | Size Code | Series 2M801 | Series 2M803 | Series 2M804 | Series 2M805 |
| .2500-32 UNEF-2B | 05 | 5 | 5 | 5 | |
| .3125-32 UNEF-2B | 06 | 6 | 6 | 6 | |
| .3750-32 UNEF-2B | 11 | | | | 8 |
| .4375-28 UNEF-2B | 07 | 7 | 7 | 7 | 9 |
| .5000-28 UNEF-2B | 08 | 8 | 8 | 8 | 10 |
| .5625-24 UNEF-2B | 09 | 9 | 9 | 9 | 11 |
| .6250-24 UNEF-2B | 10 | 10 | 10 | 10 | 12 |
| .6875-24 UNEF-2B | 12 | 13 | 12 | 12 | |
| .7500-20 UNEF-2B | 13 | | | | 15 |
| .9375-20 UNEF-2B | 14 | 16,17 | 14, 15 | 14, 15 | 18, 19 |
| 1.1875-18 UNEF-2B | 17 | 21 | | | 23 |

| MATERIALS | |
|---------------------------------|--|
| Adapter, Clamp, Nut and Saddles | Aluminum Alloy 6061-T6 or 300 Series Stainless Steel |
| O-Rings | Silicone Rubber |
| Hardware | 300 Series Stainless Steel |

Accessories
Contacts Tools

2M Environmental EMI Backshell

2M390MS077, MS076, MB077 and MA077

STRAIGHT ENTRY
ROTATABLE COUPLING
2M390MS077

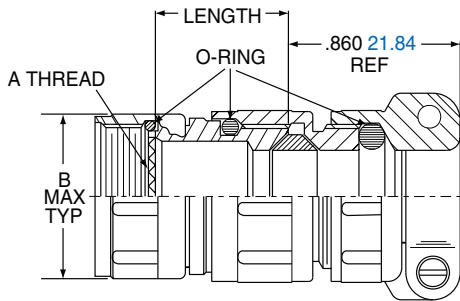

STRAIGHT ENTRY
DIRECT COUPLING
2M390MS076

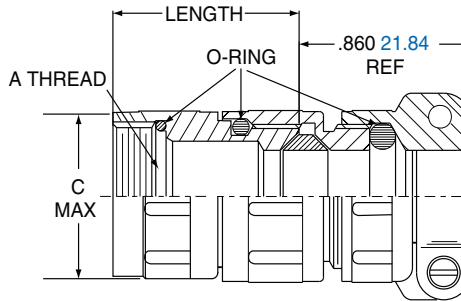

CLAMP STYLE N
COMPRESSION NUT

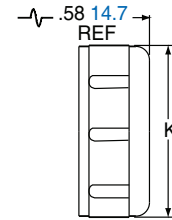

45° ENTRY
ROTATABLE COUPLING
2M390MB077

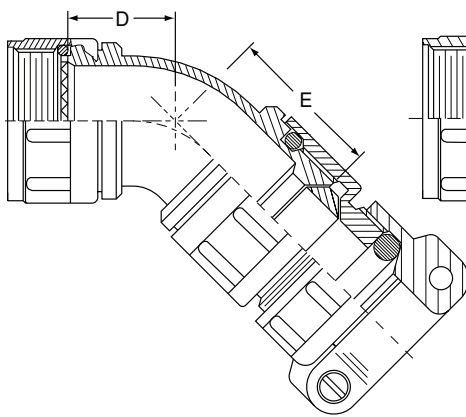

90° ENTRY
ROTATABLE COUPLING
2M390MA077

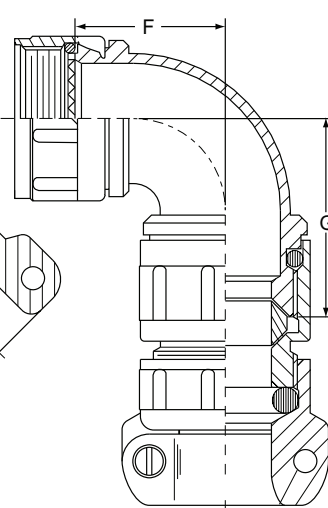

SADDLE CLAMP

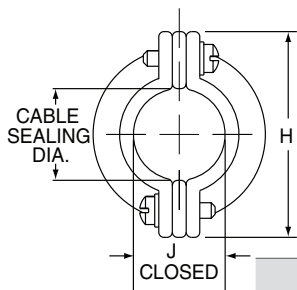

| Size Code | A Threads UNEF-2B | B Max. | | C Max. | |
|-----------|-------------------|--------|-------|--------|-------|
| | | in. | mm. | in. | mm. |
| 05 | .2500-32 | .470 | 11.94 | .350 | 8.89 |
| 06 | .3125-32 | .530 | 13.46 | .415 | 10.54 |
| 11 | .3750-32 | .570 | 14.48 | .570 | 14.48 |
| 07 | .4375-28 | .637 | 16.18 | .530 | 13.46 |
| 08 | .5000-28 | .700 | 17.78 | .595 | 15.11 |
| 09 | .5625-24 | .758 | 19.25 | .650 | 16.51 |
| 10 | .6250-24 | .819 | 20.80 | .715 | 18.16 |
| 12 | .6875-24 | .896 | 22.76 | .785 | 19.94 |
| 13 | .7500-20 | .930 | 23.62 | .830 | 21.08 |
| 14 | .9375-20 | 1.137 | 28.88 | 1.020 | 25.91 |
| 17 | 1.1875-18 | 1.387 | 35.23 | 1.280 | 32.51 |

| Ca- ble Entry Code | Cable Sealing Dia. | | CABLE ENTRY | | | | | | | | H | | J Dia. Closed | | K Dia. | |
|-----------------------------|--------------------------|------|-------------|-------|--------|-------|--------|-------|--------|-------|---------------|---------------|---------------|---------------|---------------|---------------|
| | | | D Max. | | E Max. | | F Max. | | G Max. | | in. ± .010 | mm. ± 0.25 | in. ± .030 | mm. ± 0.76 | in. ± .010 | mm. ± 0.25 |
| | | | Max. | Min. | In. | mm. | in. | mm. | in. | mm. | | | | | | |
| 01 | .109 | .031 | .603 | 15.32 | .681 | 14.67 | .724 | 18.39 | .802 | 20.37 | .496 | 12.60 | .110 | 2.79 | .398 | 10.11 |
| 02 | .172 | .078 | .603 | 15.32 | .681 | 14.67 | .724 | 18.39 | .802 | 20.37 | .582 | 14.78 | .170 | 4.32 | .460 | 11.68 |
| 03 | .234 | .140 | .603 | 15.32 | .681 | 14.67 | .724 | 18.39 | .802 | 20.37 | .656 | 16.66 | .230 | 5.84 | .523 | 13.28 |
| 04 | .297 | .203 | .629 | 15.98 | .707 | 15.42 | .786 | 19.96 | .864 | 21.95 | .726 | 18.44 | .300 | 7.62 | .585 | 14.86 |
| 05 | .359 | .265 | .629 | 15.98 | .707 | 15.42 | .786 | 19.96 | .864 | 21.95 | .885 | 22.48 | .360 | 9.14 | .647 | 16.43 |
| 06 | .422 | .328 | .655 | 16.64 | .733 | 16.00 | .848 | 21.54 | .926 | 23.52 | .952 | 24.18 | .420 | 10.67 | .710 | 18.03 |
| 07 | .484 | .390 | .655 | 16.64 | .733 | 16.00 | .848 | 21.54 | .926 | 23.52 | 1.018 | 25.86 | .480 | 12.19 | .773 | 19.63 |
| 08 | .547 | .453 | .707 | 17.96 | .785 | 17.40 | .911 | 23.14 | .989 | 25.12 | 1.084 | 27.53 | .550 | 13.97 | .835 | 21.21 |
| 09 | .609 | .515 | .707 | 17.96 | .785 | 17.40 | .911 | 23.14 | .989 | 25.12 | 1.148 | 29.16 | .610 | 15.49 | .897 | 22.78 |

2M Shorting Cap Backshell Ordering Info

2M340MS026



| 1. | 2. | 3. | 4. | 5. | 6. | 5. |
|-------------|---------------|-----------------|-----------|--------|-----------------|--------|
| PART NUMBER | SERVICE CLASS | ATTACHMENT TYPE | SIZE CODE | LENGTH | ATTACHMENT CODE | LENGTH |
| 2M340MS026 | -M | -G | 07 | -4 | 02 | -5 |

Omit for attachment Type N (No Attachment) Ex. "-5" equals five inch length

| 1. PART NUMBER | | 2. SERVICE CLASS | | | 3. ATTACHMENT TYPE | | 4. SIZE CODE | | |
|----------------|------------------------|------------------|--------|---------------------------------|--------------------|-----------|--|----|----------|
| Part # | Description | Material | Part # | Description | RoHS | | | | |
| 2M340MS026 | Shorting Cap Backshell | ALUMINUM | -C | Black Anodized (Non-conductive) | | -G | Nylon Rope | 05 | .2500-32 |
| | | | -M | Electroless Nickel | | -H | Stainless Steel Wire Rope, Teflon® Jacket | 06 | .3125-32 |
| | | | -NF | Olive Drab Cadmium | | -N | No Attachment | 11 | .3750-32 |
| | | | -MT | Durmalon (Ni PTFE) | | -S | Stainless Steel Sash Chain | 07 | .4375-28 |
| | | | -ZN | Olive Drab Zinc Nickel | | -SK | Nylon Rope With Slip Knot | 08 | .5000-28 |
| | | | -ZNU | Black Zinc Nickel | | -U | Stainless Steel Wire Rope, Polyurethane Jacket | 09 | .5625-24 |
| | | | -Z1 | Passivated | | | | 10 | .6250-24 |
| | | | -ZL | Electrolytic Nickel | | | | 12 | .6875-24 |
| | | | | | | | | 13 | .7500-20 |
| | | | | | | | | 14 | .9375-20 |
| | | | | | 17 | 1.1875-18 | | | |

| 5. LENGTH | |
|--------------------------|-----------------|
| Overall Length in Inches | |
| Length Code | Length (inches) |
| -4 | .50 |
| -5 | .75 |
| -6 | 1.00 |
| -7 | 1.25 |
| -8 | 1.50 |
| -9 | 1.75 |
| -10 | 2.00 |
| -11 | 2.25 |
| -12 | 2.50 |
| -13 | 2.75 |
| -14 | 3.00 |

| 6. ATTACHMENT CODE | |
|--|--|
| Omit for attachment Types N (No Attachment) and SK (Slip Knot) | |
| | SMALL RING 01 –.126 (3.20) I.D. 02 –.145 (3.68) I.D. 04 –.188 (4.78) I.D. 06 –.197 (5.00) I.D. |
| | LARGE RING 14 –.385 (9.78) I.D. 15 –.445 (11.30) I.D. 16 –.570 (14.48) I.D. 17 –.635 (16.13) I.D. 18 –.695 (17.65) I.D. 19 –.885 (22.48) I.D. 20 –1.070 (27.17) I.D. |
| | SPLIT RING 50 –.420 (10.67) I.D. 52 –.480 (12.19) I.D. 54 –.635 (16.13) I.D. 56 –.745 (18.92) I.D. 58 –.885 (22.48) I.D. 60 –1.010 (25.65) I.D. 64 –1.125 (28.58) I.D. 68 –1.345 (34.16) I.D. |

| MATERIALS | |
|---------------------------------|--|
| Adapter, Clamp, Nut and Saddles | Aluminum Alloy 6061-T6 or 300 Series Stainless Steel |
| Hardware | 300 Series SST |
| O-Ring | Silicone Elastomer |

Assembly Instructions for Protection Cap, see page 100.

2M Shorting Cap Backshell Dimensions

2M340MS026

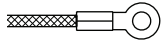

Small Ring for Attaching to a Panel with a Screw

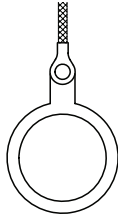

Large Solid Ring for Attaching to a Jam Nut Receptacle

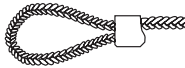

Nylon Rope Slip Knot (SK) for attaching Covers to Cables

ATTACHMENT OPTIONS

| Dia. Code | Ring I.D. | | Ring O. D. | |
|-----------|-----------|-------|------------|-------|
| | in. | mm. | in. | mm. |
| | ± .005 | ± .13 | Max | Max |
| 01 | .126 | 8.89 | .31 | 7.9 |
| 02 | .145 | 10.54 | .31 | 7.9 |
| 04 | .188 | 11.81 | .31 | 7.9 |
| 06 | .197 | 13.46 | .31 | 7.9 |
| Dia. Code | Ring I.D. | | Ring O. D. | |
| | in. | mm. | in. | mm. |
| | ± .010 | ± .25 | ± .015 | ± .38 |
| 14 | .385 | 9.78 | .510 | 12.95 |
| 15 | .445 | 11.30 | .565 | 14.35 |
| 16 | .570 | 14.48 | .685 | 17.40 |
| 17 | .635 | 16.13 | .760 | 19.30 |
| 18 | .695 | 17.65 | .820 | 20.82 |
| 19 | .885 | 22.48 | 1.010 | 25.65 |
| 20 | 1.070 | 27.17 | 1.195 | 30.35 |
| 21 | 1.135 | 28.83 | 1.250 | 31.75 |
| 22 | 1.210 | 30.73 | 1.312 | 33.32 |

55° to +100°C., black, flexible, good abrasion resistance, good resistance to fuels, .120" 3mm diameter. Length includes .5" 13mm diameter loop.

DIMENSIONS

| Size Code | A Max Dia. | | B Threads |
|-----------|------------|-------|-------------------|
| | in. | mm. | |
| 05 | .350 | 8.89 | .2500-32 UNEF-2B |
| 06 | .415 | 10.54 | .3125-32 UNEF-2B |
| 11 | .465 | 11.81 | .3750-32 UNEF-2B |
| 07 | .530 | 13.46 | .4375-28 UNEF-2B |
| 08 | .595 | 14.35 | .5000-28 UNEF-2B |
| 09 | .650 | 16.51 | .5625-24 UNEF-2B |
| 10 | .715 | 18.16 | .6250-24 UNEF-2B |
| 12 | .785 | 19.94 | .6875-24 UNEF-2B |
| 13 | .830 | 21.08 | .7500-20 UNEF-2B |
| 14 | 1.020 | 25.91 | .9375-20 UNEF-2B |
| 17 | 1.270 | 32.26 | 1.1875-18 UNEF-2B |

LANYARD OPTIONS

| | |
|--------------------------------------|---|
| <p>Nylon Rope</p> | -55° to +100°C., black, very flexible, good abrasion resistance, good resistance to fuels, .120" 3mm diameter |
| <p>Polyurethane Coated Wire Rope</p> | Black polyurethane over stainless steel rope, very flexible, excellent abrasion resistance, excellent resistance to fuels, .080" 2mm diameter |
| <p>Teflon® Jacketed Wire Rope</p> | Translucent FEP jacket over stainless steel, -55° to +200°C., fair flexibility, good abrasion resistance, .100" diameter |
| <p>Sash Chain</p> | Stainless steel, #8 chain, .240" 6mm diameter |

2M Series Backshells and Accessories

2M809S060, 2M809A060 Shrink Boots



The 2M Series of Shrink Boots is intended for use with the 2M series of connectors supplied with Banding Platforms. All shrink boots are supplied pre-coated with Hi-Temperature, Hot-Melt adhesive that will seal the boot to both the cable and connector. The boots also contains a lip that will lock on to a groove on the connector for improved strain relief.

High Performance Elastomer - Lipped Shrink Boot

- Pre-coated with Adhesive
- Operating Temperature: -70°C to +150°C
- Rated for 3000 hrs. continuous operation at +150°C
- Excellent resistance to fuels, oils, and solvents

| Material | Spec |
|-------------------------|-----------------|
| Fluid Resistant Polymer | VG 95343 Part 6 |

| Boot Size | Shell Size | | Straight Shrink Boots Part Number | Right Angle Boots Part Number |
|-----------|----------------------------|--------------|---|---|
| | Series 2M801, 2M803, 2M804 | Series 2M805 | Pre-Coated with Hi-Temp Hot-Melt Adhesive | Pre-Coated with Hi-Temp Hot-Melt Adhesive |
| 1 | 5 | N/A | 2M809S060-1G | 2M809A060-1G |
| 2 | 6, 7 | 8,9 | 2M809S060-2G | 2M809A060-2G |
| 3 | 8, 9 | 10,11 | 2M809S060-3G | 2M809A060-3G |
| 4 | 10, 12, 13 | 12, 15 | 2M809S060-4G | 2M809A060-4G |
| 5 | 14, 15, 16, 17 | 18, 19 | 2M809S060-5G | 2M809A060-5G |
| 6 | 21 | 23 | 2M809S060-6G | 2M809A060-6G |

Zero Halogen - Lipped Shrink Boots

- Low Smoke, Zero Halogen
- Toxicity Requirements: Meets U.S. and EU standards
- Pre-coated with Adhesive
- Operating Temperature: -30°C to +125°C
- Good resistance to fuels, oils, and solvents

| Material | Spec |
|------------------------|----------------|
| Low Smoke Halogen Free | NAVSEA 5617649 |

| Boot Size | Shell Size | | Straight Shrink Boot Part Number | Right Angle Shrink Boots Part Number |
|-----------|----------------------------|--------------|---|---|
| | Series 2M801, 2M803, 2M804 | Series 2M805 | Pre-Coated with Hi-Temp Hot-Melt Adhesive | Pre-Coated with Hi-Temp Hot-Melt Adhesive |
| 1 | 5 | N/A | 2M809S060-1H | 2M809A060-1H |
| 2 | 6, 7 | 8,9 | 2M809S060-2H | 2M809A060-2H |
| 3 | 8, 9 | 10,11 | 2M809S060-3H | 2M809A060-3H |
| 4 | 10, 12, 13 | 12, 15 | 2M809S060-4H | 2M809A060-4H |
| 5 | 14, 15, 16, 17 | 18, 19 | 2M809S060-5H | 2M809A060-5H |
| 6 | 21 | 23 | 2M809S060-6H | 2M809A060-6H |

Size 1 right angle supplied less lip see page 108

Series 2M Torque Values

| Series 2M801, 2M803, 2M804, 2M805 Recommended Torque Values | | | | | |
|---|-------------------------|----------------------|------|------|------|
| Shell Size Series 2M801, 2M803, 2M804 | Shell Size Series 2M805 | Backshell Tightening | | | |
| | | In-LBs. | | N-m | |
| | | Min. | Max. | Min. | Max. |
| 5 | - | 13 | 17 | 1.5 | 1.9 |
| 6 | 8 | 18 | 22 | 2.0 | 2.5 |
| 7 | 9 | 30 | 40 | 3.4 | 4.5 |
| 8 | 10 | 30 | 40 | 3.4 | 4.5 |
| 9 | 11 | 35 | 45 | 4.0 | 5.1 |
| 10 | 12 | 35 | 45 | 4.0 | 5.1 |
| 12, 13 | 15 | 35 | 45 | 4.0 | 5.1 |
| 14, 16 | 18 | 35 | 45 | 4.0 | 5.1 |
| 15, 17 | 19 | 35 | 45 | 4.0 | 5.1 |
| 21 | 23 | 35 | 45 | 4.0 | 5.1 |



2M Backshells and Accessories

2M809S060, 2M809A060 Shrink Boots

Lipped Straight Shrink Boots

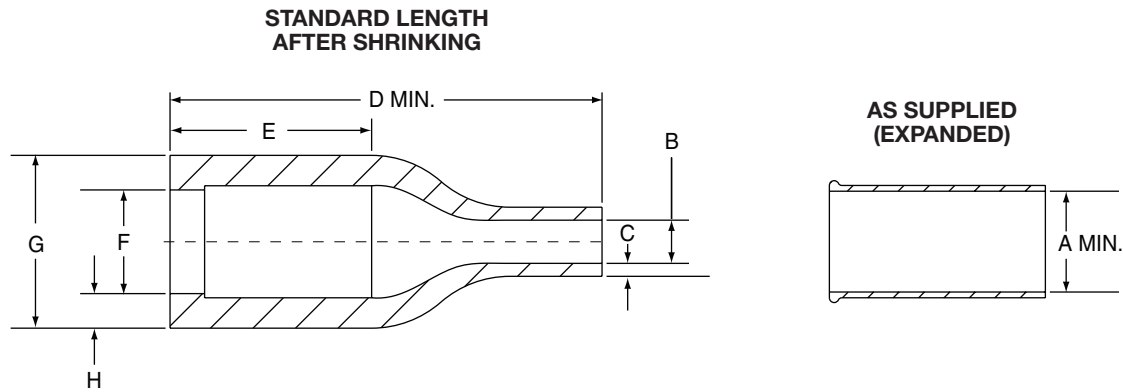

| Boot Size | A Min. | | B Max. | | C±20% | | D±10% | | E Ref. | | F Max. | | G Ref. | | H±30% | |
|-----------|--------|------|--------|------|-------|------|-------|-------|--------|------|--------|-------|--------|-------|-------|------|
| | in. | mm. | in. | mm. | in. | mm. | in. | mm. | in. | mm. | in. | mm. | in. | mm. | in. | mm. |
| 1 | .350 | 9.0 | .075 | 1.91 | .023 | .584 | .750 | 19.0 | .350 | 9.0 | .182 | 4.62 | .300 | 7.6 | .060 | 1.52 |
| 2 | .650 | 16.5 | .150 | 3.8 | .050 | 1.27 | 1.000 | 25.4 | .560 | 14.2 | .238 | 6.05 | .410 | 10.5 | .090 | 2.29 |
| 3 | .920 | 23.4 | .220 | 5.6 | .060 | 1.52 | 1.500 | 38.1 | 0.830 | 21.1 | .338 | 8.59 | .530 | 13.46 | .100 | 2.54 |
| 4 | 1.120 | 28.4 | .260 | 6.6 | .070 | 1.78 | 2.160 | 54.9 | 1.090 | 27.7 | .488 | 12.40 | .700 | 17.8 | .110 | 2.79 |
| 5 | 1.220 | 31.0 | .280 | 7.1 | .080 | 2.03 | 2.640 | 67.0 | 1.380 | 35.0 | .628 | 15.95 | .860 | 21.8 | .120 | 3.05 |
| 6 | 1.680 | 42.7 | .390 | 9.9 | .080 | 2.03 | 4.080 | 103.6 | 2.220 | 56.4 | .984 | 25.00 | 1.270 | 32.2 | .143 | 3.63 |

Lipped Right Angle Shrink Boots

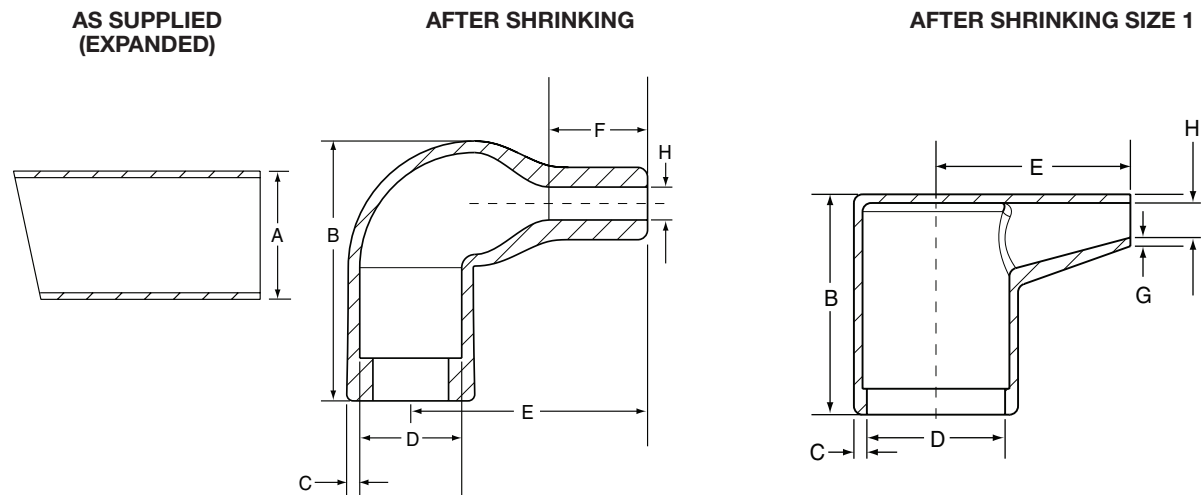

| Boot Size | A Min. | | B Ref. | | C±30% | | D Max. | | E±20% | | F Ref. | | G±20% | | H Max | |
|-----------|--------|------|--------|------|-------|-----|--------|------|-------|------|--------|------|-------|-----|-------|-----|
| | in. | mm. | in. | mm. | in. | mm. | in. | mm. | in. | mm. | in. | mm. | in. | mm. | in. | mm. |
| 1 | .240 | 6.0 | .510 | 13.0 | .040 | 1.0 | .322 | 8.18 | .410 | 10.5 | N/A | N/A | .020 | 0.5 | .080 | 2.0 |
| 2 | .650 | 16.5 | .790 | 20.1 | .040 | 1.0 | .310 | 7.9 | .720 | 18.3 | .300 | 7.62 | .060 | 1.6 | .100 | 2.5 |
| 3 | .920 | 23.3 | .900 | 22.9 | .050 | 1.3 | .410 | 10.4 | .800 | 20.3 | .230 | 5.8 | .050 | 1.3 | .220 | 5.6 |
| 4 | 1.120 | 28.5 | 1.120 | 28.5 | .060 | 1.5 | .560 | 14.2 | 1.170 | 29.8 | .280 | 7.1 | .060 | 1.5 | .250 | 6.3 |
| 5 | 1.220 | 30.9 | 1.200 | 30.5 | .070 | 1.8 | .700 | 17.8 | 1.400 | 35.6 | .340 | 8.6 | .070 | 1.8 | .280 | 7.1 |
| 6 | 1.680 | 42.6 | 1.700 | 43.2 | .080 | 2.0 | 1.100 | 27.9 | 2.100 | 53.3 | .620 | 15.7 | .080 | 2.0 | .380 | 9.7 |

2M Backshells and Accessories

Hex Jam Nuts for 2M Receptacles- 2M809-035

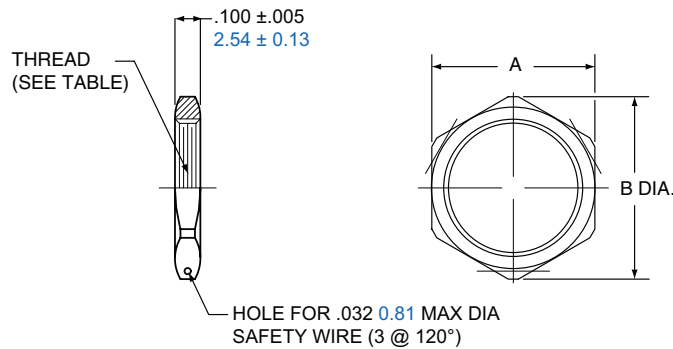

| Thread Size Class 2B | Part Number | | | | | | Dimensions | | | |
|-------------------------|-----------------------|-----------------------|----------------------|-----------------|----------------|-----------------------|------------|-------|--------|-------|
| | Aluminum | | | Stainless Steel | | | A Hex. | | B Dia. | |
| | Electroless Nickel | Olive Drab Cadmium | Black Zinc Nickel | Nickel-PTFE | Passivated | Black Zinc- Cobalt | In. | mm. | In. | mm. |
| .2500-32 UNEF | 2M809-035M01W | 2M809-035NF01W | 2M809-035ZNU01W | 2M809-035MT01W | 2M809-035Z101W | 2M809-035ZC01W | .375 | 9.53 | .403 | 10.24 |
| .3125-28 UN | 2M809-035M02W | 2M809-035NF02W | 2M809-035ZNU02W | 2M809-035MT02W | 2M809-035Z102W | 2M809-035ZC02W | .4375 | 11.11 | .475 | 12.07 |
| .3125-32 UNEF | 2M809-035M03W | 2M809-035NF03W | 2M809-035ZNU03W | 2M809-035MT03W | 2M809-035Z103W | 2M809-035ZC03W | .4375 | 11.11 | .475 | 12.07 |
| .3750-28 UN | 2M809-035M04W | 2M809-035NF04W | 2M809-035ZNU04W | 2M809-035MT04W | 2M809-035Z104W | 2M809-035ZC04W | .500 | 12.70 | .547 | 13.89 |
| .4375-28 UNEF | 2M809-035M05W | 2M809-035NF05W | 2M809-035ZNU05W | 2M809-035MT05W | 2M809-035Z105W | 2M809-035ZC05W | .5625 | 14.29 | .620 | 15.75 |
| .5625-24 UNEF | 2M809-035M06W | 2M809-035NF06W | 2M809-035ZNU06W | 2M809-035MT06W | 2M809-035Z106W | 2M809-035ZC06W | .6875 | 17.46 | .755 | 19.18 |
| .5625-28 UN | 2M809-035M16W | 2M809-035NF16W | 2M809-035ZNU16W | 2M809-035MT16W | 2M809-035Z116W | 2M809-035ZC16W | .6875 | 17.46 | .755 | 19.18 |
| .5625-32 UN | 2M809-035M07W | 2M809-035NF07W | 2M809-035ZNU07W | 2M809-035MT07W | 2M809-035Z107W | 2M809-035ZC07W | .6875 | 17.46 | .755 | 19.18 |
| .6250-28 UN | 2M809-035M08W | 2M809-035NF08W | 2M809-035ZNU08W | 2M809-035MT08W | 2M809-035Z108W | 2M809-035ZC08W | .750 | 19.05 | .830 | 21.08 |
| .6875-28 UN | 2M809-035M09W | 2M809-035NF09W | 2M809-035ZNU09W | 2M809-035MT09W | 2M809-035Z109W | 2M809-035ZC09W | .8125 | 20.64 | .898 | 22.81 |
| .7500-28 UN | 2M809-035M10W | 2M809-035NF10W | 2M809-035ZNU10W | 2M809-035MT10W | 2M809-035Z110W | 2M809-035ZC10W | .875 | 22.23 | .970 | 24.64 |
| .8125-28 UN | 2M809-035M17W | 2M809-035NF17W | 2M809-035ZNU17W | 2M809-035MT17W | 2M809-035Z117W | 2M809-035ZC17W | .9375 | 23.81 | 1.030 | 26.16 |
| .8750-28 UN | 2M809-035M11W | 2M809-035NF11W | 2M809-035ZNU11W | 2M809-035MT11W | 2M809-035Z111W | 2M809-035ZC11W | 1.000 | 25.40 | 1.078 | 27.38 |
| .9375-20 UNEF | 2M809-035M12W | 2M809-035NF12W | 2M809-035ZNU12W | 2M809-035MT12W | 2M809-035Z112W | 2M809-035ZC12W | 1.0625 | 26.99 | 1.187 | 30.15 |
| .9375-28 UN | 2M809-035M13W | 2M809-035NF13W | 2M809-035ZNU13W | 2M809-035MT13W | 2M809-035Z113W | 2M809-035ZC13W | 1.0625 | 26.99 | 1.187 | 30.15 |
| 1.0000-28 UN | 2M809-035M18W | 2M809-035NF18W | 2M809-035ZNU18W | 2M809-035MT18W | 2M809-035Z118W | 2M809-035ZC18W | 1.125 | 28.58 | 1.200 | 30.48 |
| 1.0625-20 UN | 2M809-035M14W | 2M809-035NF14W | 2M809-035ZNU14W | 2M809-035MT14W | 2M809-035Z114W | 2M809-035ZC14W | 1.1875 | 30.16 | 1.264 | 32.11 |
| 1.1250-28 UN | 2M809-035M15W | 2M809-035NF15W | 2M809-035ZNU15W | 2M809-035MT15W | 2M809-035Z115W | 2M809-035ZC15W | 1.250 | 31.75 | 1.325 | 33.66 |
| 1.1875-28 UN | 2M809-035M19W | 2M809-035NF19W | 2M809-035ZNU19W | 2M809-035MT19W | 2M809-035Z119W | 2M809-035ZC19W | 1.3125 | 33.34 | 1.415 | 35.94 |
| 1.2500-28 UN | 2M809-035M20W | 2M809-035NF20W | 2M809-035ZNU20W | 2M809-035MT20W | 2M809-035Z120W | 2M809-035ZC20W | 1.375 | 34.93 | 1.490 | 37.85 |
| 1.5000-28 UN | 2M809-035M21W | 2M809-035NF21W | 2M809-035ZNU21W | 2M809-035MT21W | 2M809-035Z121W | 2M809-035ZC21W | 1.625 | 41.28 | 1.750 | 44.45 |

Accessories
Contacts Tools

2M Backshells and Accessories

Flange Gaskets 2M809-108

Flange Gaskets for Series 2M801 Receptacles

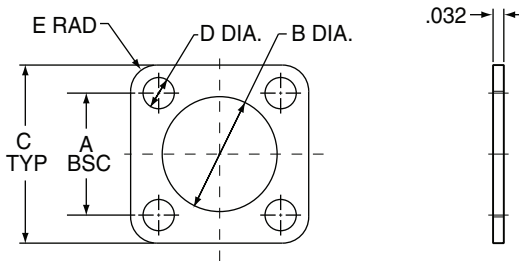

| Shell Size | Part Number | | | A Bsc. | | B Dia. | | C Typ. | | D Dia. | | E Rad. | |
|------------|----------------|--------------|---------------------------|--------|-------|--------|-------|--------|-------|--------|------|--------|------|
| | Fluorosilicone | Viton® | Conductive Fluorosilicone | in. | mm. | in. | mm. | in. | mm. | in. | mm. | in. | mm. |
| 5 | 2M809-108F11 | 2M809-108V11 | 2M809-108X11 | .363 | 9.22 | .342 | 8.69 | .530 | 13.46 | .093 | 2.36 | .078 | 1.98 |
| 6 | 2M809-108F12 | 2M809-108V12 | 2M809-108X12 | .423 | 10.74 | .405 | 10.29 | .590 | 14.99 | .093 | 2.36 | .078 | 1.98 |
| 7 | 2M809-108F13 | 2M809-108V13 | 2M809-108X13 | .483 | 12.27 | .467 | 11.86 | .650 | 16.51 | .093 | 2.36 | .078 | 1.98 |
| 8 | 2M809-108F14 | 2M809-108V14 | 2M809-108X14 | .545 | 13.84 | .530 | 13.46 | .712 | 18.08 | .093 | 2.36 | .078 | 1.98 |
| 9 | 2M809-108F16 | 2M809-108V16 | 2M809-108X16 | .607 | 15.42 | .560 | 14.22 | .850 | 21.59 | .125 | 3.18 | .105 | 2.67 |
| 10 | 2M809-108F15 | 2M809-108V15 | 2M809-108X15 | .670 | 17.02 | .655 | 16.64 | .890 | 22.61 | .125 | 3.18 | .105 | 2.67 |
| 13 | 2M809-108F17 | 2M809-108V17 | 2M809-108X17 | .812 | 20.62 | .842 | 21.39 | 1.030 | 26.16 | .125 | 3.18 | .105 | 2.67 |
| 16 | 2M809-108F18 | 2M809-108V18 | 2M809-108X18 | .981 | 24.92 | 1.030 | 26.16 | 1.219 | 30.96 | .125 | 3.18 | .105 | 2.67 |
| 17 | 2M809-108F19 | 2M809-108V19 | 2M809-108X19 | 1.060 | 26.92 | 1.092 | 27.74 | 1.280 | 32.51 | .125 | 3.18 | .105 | 2.67 |
| 21 | 2M809-108F43 | 2M809-108V43 | 2M809-108X43 | 1.205 | 30.61 | 1.332 | 33.83 | 1.427 | 36.25 | .125 | 3.18 | .105 | 2.67 |

Flange Gaskets for Series 2M803 Receptacles

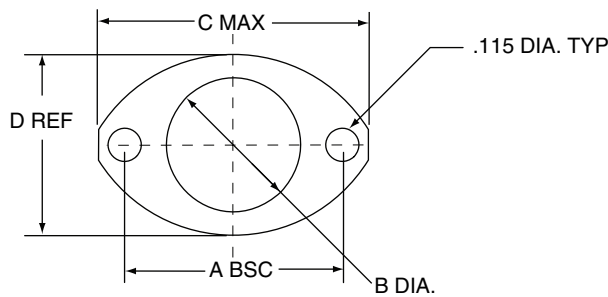

| Shell Size | Part Number | | | A Bsc. | | B Dia. | | C Max. | | D Ref. | |
|------------|----------------|--------------|---------------------------|--------|-------|--------|-------|--------|-------|--------|-------|
| | Fluorosilicone | Viton® | Conductive Fluorosilicone | in. | mm. | in. | mm. | in. | mm. | in. | mm. |
| 5 | 2M809-108F31 | 2M809-108V31 | 2M809-108X31 | .513 | 13.03 | .345 | 8.00 | .710 | 18.03 | .460 | 11.68 |
| 6 | 2M809-108F32 | 2M809-108V32 | 2M809-108X32 | .598 | 15.19 | .405 | 10.29 | .795 | 20.19 | .522 | 13.26 |
| 7 | 2M809-108F33 | 2M809-108V33 | 2M809-108X33 | .708 | 17.98 | .475 | 12.07 | .900 | 22.86 | .590 | 14.99 |
| 8 | 2M809-108F34 | 2M809-108V34 | 2M809-108X34 | .964 | 24.51 | .545 | 13.84 | 1.160 | 29.46 | .670 | 17.02 |
| 9 | 2M809-108F35 | 2M809-108V35 | 2M809-108X35 | 1.017 | 25.83 | .605 | 15.37 | 1.215 | 30.86 | .721 | 18.31 |
| 10 | 2M809-108F36 | 2M809-108V36 | 2M809-108X36 | 1.101 | 37.97 | .682 | 17.32 | 1.295 | 32.89 | .795 | 20.19 |
| 12 | 2M809-108F37 | 2M809-108V37 | 2M809-108X37 | 1.204 | 30.58 | .757 | 19.23 | 1.400 | 35.56 | .874 | 22.20 |
| 14 | 2M809-108F38 | 2M809-108V38 | 2M809-108X38 | 1.280 | 32.51 | .910 | 23.11 | 1.555 | 39.50 | 1.050 | 26.67 |
| 15 | 2M809-108F39 | 2M809-108V39 | 2M809-108X39 | 1.370 | 34.80 | .970 | 24.64 | 1.640 | 41.66 | 1.150 | 29.21 |

2M Backshells and Accessories

Flange Gaskets 2M809-108



Flange Gaskets for Series 2M805 Receptacles

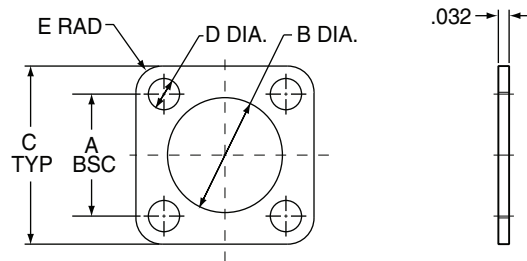

| Shell Size | Part Number | | | A Bsc. | | B Dia. | | C Typ. | | D Dia. | | E Rad. | |
|------------|----------------|--------------|---------------------------|--------|-------|--------|-------|--------|-------|--------|------|--------|------|
| | Fluorosilicone | Viton® | Conductive Fluorosilicone | in. | mm. | in. | mm. | in. | mm. | in. | mm. | in. | mm. |
| 8 | 2M809-108F20 | 2M809-108V20 | 2M809-108X20 | .660 | 16.76 | .530 | 13.46 | .850 | 21.46 | .093 | 2.36 | .078 | 1.98 |
| 9 | 2M809-108F21 | 2M809-108V21 | 2M809-108X21 | .723 | 18.36 | .590 | 14.99 | .913 | 23.19 | .093 | 2.36 | .078 | 1.98 |
| 10 | 2M809-108F22 | 2M809-108V22 | 2M809-108X22 | .785 | 19.94 | .660 | 16.76 | .975 | 24.77 | .093 | 2.36 | .078 | 1.98 |
| 11 | 2M809-108F23 | 2M809-108V23 | 2M809-108X23 | .848 | 21.54 | .720 | 18.29 | 1.039 | 26.39 | .093 | 2.36 | .078 | 1.98 |
| 12 | 2M809-108F24 | 2M809-108V24 | 2M809-108X24 | .909 | 23.09 | .780 | 19.81 | 1.099 | 27.91 | .093 | 2.36 | .078 | 1.98 |
| 15 | 2M809-108F25 | 2M809-108V25 | 2M809-108X25 | 1.058 | 26.87 | .970 | 24.64 | 1.288 | 32.72 | .125 | 3.18 | .105 | 2.67 |
| 18 | 2M809-108F26 | 2M809-108V26 | 2M809-108X26 | 1.255 | 31.88 | 1.160 | 29.46 | 1.475 | 37.47 | .125 | 3.18 | .105 | 2.67 |
| 19 | 2M809-108F27 | 2M809-108V27 | 2M809-108X27 | 1.327 | 33.71 | 1.220 | 30.99 | 1.537 | 39.04 | .125 | 3.18 | .105 | 2.67 |
| 23 | 2M809-108F28 | 2M809-108V28 | 2M809-108X28 | 1.570 | 39.88 | 1.458 | 37.03 | 1.797 | 45.64 | .125 | 3.18 | .105 | 2.67 |

2M Backshells and Accessories

O-Rings 2M809-109

O-Rings Series 2M801 Jam Nut Receptacles

| Shell Size | Part Number | | | | Inside Dia. | | Cross-Section | |
|------------|----------------|---------------|-----------------------------------|--|-------------|-------|---------------|------|
| | Fluorosilicone | EPDM | Conductive Silicone Cho-Seal 1285 | Conductive Fluoro-Silicone Cho-Seal 1298 | in. | mm. | in. | mm. |
| 5 | 2M809-054-05F | 2M809-054-05E | 249-003-2M801-05B | 249-003-2M801-05C | .395 | 10.03 | .048 | 1.22 |
| 6 | 2M809-054-06F | 2M809-054-06E | 249-003-2M801-06B | 249-003-2M801-06C | .458 | 11.63 | .048 | 1.22 |
| 7 | 2M809-054-07F | 2M809-054-07E | 249-003-2M801-07B | 249-003-2M801-07C | .595 | 15.11 | .048 | 1.22 |
| 8 | 2M809-054-08F | 2M809-054-08E | 249-003-2M801-08B | 249-003-2M801-08C | .595 | 15.11 | .048 | 1.22 |
| 9 | 2M809-054-09F | 2M809-054-09E | 249-003-2M801-09B | 249-003-2M801-09C | .660 | 16.76 | .048 | 1.22 |
| 10 | 2M809-054-10F | 2M809-054-10E | 249-003-2M801-10B | 249-003-2M801-10C | .710 | 18.03 | .048 | 1.22 |
| 13 | 2M809-054-13F | 2M809-054-13E | 249-003-2M801-13B | 249-003-2M801-13C | .900 | 22.86 | .048 | 1.22 |
| 16 | 2M809-054-16F | 2M809-054-16E | 249-003-2M801-16B | 249-003-2M801-16C | 1.090 | 27.69 | .048 | 1.22 |
| 17 | 2M809-054-17F | 2M809-054-17E | 249-003-2M801-17B | 249-003-2M801-17C | 1.135 | 28.83 | .048 | 1.22 |
| 21 | 2M809-054-21F | 2M809-054-21E | 249-003-2M801-21B | 249-003-2M801-21C | 1.535 | 38.99 | .048 | 1.22 |

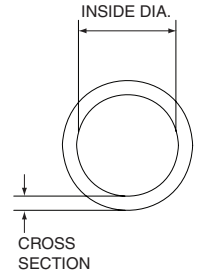

O-Rings Series 2M804 Rear Mount Jam Nut Receptacles

| Shell Size | Part Number | | | | Inside Diameter | | Cross Section | |
|------------|----------------|---------------|-----------------------------------|---|-----------------|-------|---------------|------|
| | Fluorosilicone | EPDM | Conductive Silicone Cho-Seal 1285 | Conductive Fluorosilicone Cho-Seal 1298 | in. | mm. | in. | mm. |
| 5 | 2M809-055-05F | 2M809-055-05E | 249-003-2M804-05B | 249-003-2M804-05C | .489 | 12.42 | .070 | 1.78 |
| 6 | 2M809-055-06F | 2M809-055-06E | 249-003-2M804-06B | 249-003-2M804-06C | .525 | 13.34 | .070 | 1.78 |
| 7 | 2M809-055-07F | 2M809-055-07E | 249-003-2M804-07B | 249-003-2M804-07C | .630 | 16.00 | .070 | 1.78 |
| 8 | 2M809-055-08F | 2M809-055-08E | 249-003-2M804-08B | 249-003-2M804-08C | .676 | 17.17 | .070 | 1.78 |
| 9 | 2M809-055-09F | 2M809-055-09E | 249-003-2M804-09B | 249-003-2M804-09C | .739 | 18.77 | .070 | 1.78 |
| 10 | 2M809-055-10F | 2M809-055-10E | 249-003-2M804-10B | 249-003-2M804-10C | .801 | 20.35 | .070 | 1.78 |
| 12 | 2M809-055-12F | 2M809-055-12E | 249-003-2M804-12B | 249-003-2M804-12C | .926 | 23.52 | .070 | 1.78 |
| 14 | 2M809-055-14F | 2M809-055-14E | 249-003-2M804-14B | 249-003-2M804-14C | 1.051 | 26.70 | .070 | 1.78 |
| 15 | 2M809-055-15F | 2M809-055-15E | 249-003-2M804-15B | 249-003-2M804-15C | 1.114 | 28.30 | .070 | 1.78 |

O-Rings Series 2M805 Jam Nut Receptacles

| Shell Size | Part Number | | | | Inside Diameter | | Cross Section | |
|------------|----------------|---------------|-----------------------------------|---|-----------------|-------|---------------|------|
| | Fluorosilicone | EPDM | Conductive Silicone Cho-Seal 1285 | Conductive Fluorosilicone Cho-Seal 1298 | in. | mm. | in. | mm. |
| 8 | 2M809-150-08F | 2M809-150-08E | 249-003-2M805-08B | 249-003-2M805-08C | .595 | 15.11 | .048 | 1.22 |
| 9 | 2M809-150-09F | 2M809-150-09E | 249-003-2M805-09B | 249-003-2M805-09C | .710 | 18.03 | .048 | 1.22 |
| 10 | 2M809-150-10F | 2M809-150-10E | 249-003-2M805-10B | 249-003-2M805-10C | .710 | 18.03 | .048 | 1.22 |
| 11 | 2M809-150-11F | 2M809-150-11E | 249-003-2M805-11B | 249-003-2M805-11C | .785 | 19.94 | .048 | 1.22 |
| 12 | 2M809-150-12F | 2M809-150-12E | 249-003-2M805-12B | 249-003-2M805-12C | .900 | 22.86 | .048 | 1.22 |
| 15 | 2M809-150-15F | 2M809-150-15E | 249-003-2M805-15B | 249-003-2M805-15C | 1.030 | 26.16 | .048 | 1.22 |
| 18 | 2M809-150-18F | 2M809-150-18E | 249-003-2M805-18B | 249-003-2M805-18C | 1.200 | 30.48 | .048 | 1.22 |
| 19 | 2M809-150-19F | 2M809-150-19E | 249-003-2M805-19B | 249-003-2M805-19C | 1.250 | 31.75 | .048 | 1.22 |
| 23 | 2M809-150-23F | 2M809-150-23E | 249-003-2M805-23B | 249-003-2M805-23C | 1.535 | 38.99 | .048 | 1.22 |

Looking for pricing, stock, or lifecycle information?

Click below to explore more details on WIN SOURCE:

-  [View 2M801-009-01M10-201PA on WIN SOURCE](#)
-  [Amphenol Aerospace Operations Information](#)

Optimize Your Supply Chain with WIN SOURCE Solutions

-  Global Sourcing Solution
-  Obsolete Management
-  Cost Control Management
-  Shortage Management
-  Alternative Solution
-  Excess Inventory Management