

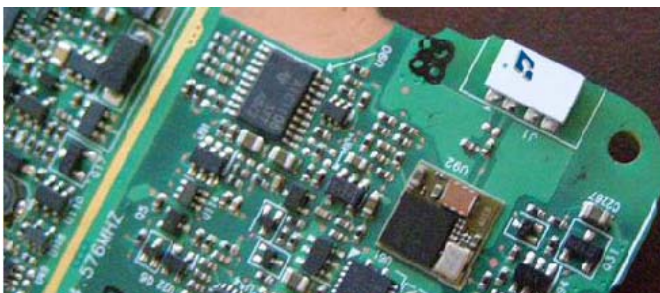

**THE DATASHEET OF
M830510**



Savvi™ Embedded Ceramic WLAN 802.11 a/b/g Antenna 2.4–2.5 and 4.9–5.8 GHz



Ethertronics' Savvi series of Isolated Magnetic Dipole™ (IMD) antennas deliver on the key needs of device designers for higher functionality and performance in smaller/thinner designs. These innovative antennas provide compelling advantages for laptops, handheld PCs, industrial devices, or other WLAN enabled equipment.

TECHNOLOGY ADVANTAGES

Real-World Performance and Implementation

Ceramic antennas may look alike on the outside, but the important difference is inside. Other antennas may contain simple PiFA or monopole designs that interact with their surroundings, complicating layout or changing performance with use position. Ethertronics' antennas utilize patented IMD technology to deliver a unique size and performance combination.



Stays in Tune

High RF isolation means IMD antennas resist detuning regardless of usage position. And one standardized part can typically be placed in a variety of locations.

Smallest Effective Size

IMD antennas require a

smaller keep-out area for surrounding components, leading to a smaller effective size.

High Performance

IMD's high efficiency and simple design rules lower development risk and speed time-to-market without sacrificing performance. Plus, high RF selectivity eliminates the cost and space for band-pass circuitry.

More information is available on our Website at www.ethertronics.com/resources/.

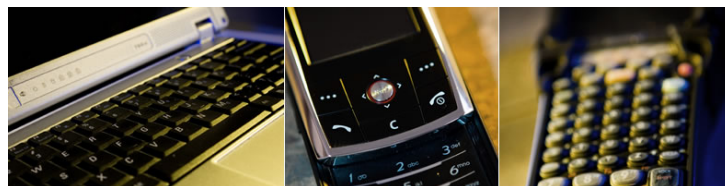

KEY BENEFITS

DESIGN ADVANTAGES

Best in Class Performance—Smallest Occupied Volume

- 81% peak efficiency
- Minimal ground clearance and component “keep out” areas. Very low component height.
- High selectivity eliminates the need for additional filters and frees board space.

High Tolerance to Frequency Shifts

- IMD's high RF isolation resists antenna de-tuning that can otherwise impair reception.
- Single part works for various PCB sizes and layouts.

Quicker Time-to-Market

- Fewer design changes
- Simpler implementation—no matching networks.

RoHS Compliant

- Antennas comply with appropriate RoHS Directives.

END USER ADVANTAGES

Superior Range

- Greater antenna efficiency means longer range.

Exceptional Coverage

- Better coverage means fewer or no dead spots, or slow speed connections, for a better end user experience.

SERVICE AND SUPPORT

Extensive RF Experience

- Our Savvi ceramic antennas are supported by extensive application notes, and when needed, by the expertise of RF engineers who have integrated hundreds of antenna designs into wireless devices.

Global Operations & Design Support

- Ethertronics' global operations encompass an integrated network of design centers that provide local customer support.

PRODUCT: WLAN Antenna

Ethertronics' Savvi™ WLAN Embedded Antenna Specifications
 Ethertronics produces a wide variety of standard and custom antennas to meet user needs.
 Below are the typical specs for a WLAN application.

Electrical Specifications

Typical Characteristics
 (inside an enclosure)

WLAN a/b/g Antenna	2.4–2.5 GHz (b/g)	4.9–5.8 GHz (a)
Peak Gain	1.1 dBi	3.2 dBi
Average Efficiency	54%	69%
VSWR Match	2.6:1 max	3.0:1 max
Feed Point Impedance	50 Ω unbalanced	

Mechanical Specifications

Size	8.00x3.00x1.33mm
Mounting	Surface mount
Weight	.2 grams
Packaging	Tape & Reel M830510: Minimum Order Quantity of 99,000 pcs. Order multiples of 4,500 pcs. M830510-1K: Minimum Order Quantity of 1,000 pcs. Order multiples of 1,000

Typical Efficiency, Return Loss

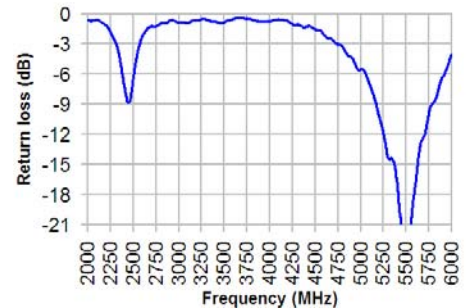
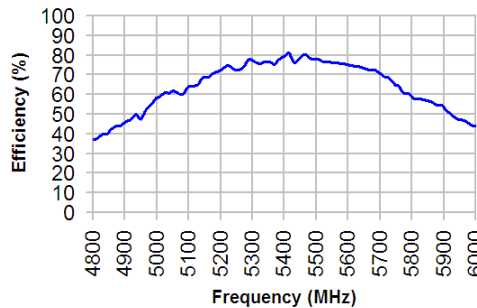
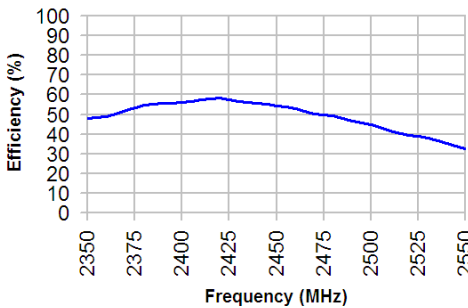

Antenna Radiation Patterns

WLAN (a)

Typical Performance
 Ethertronics' Test Board
 PCB: 40x80mm

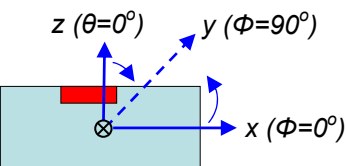

WLAN (b/g)

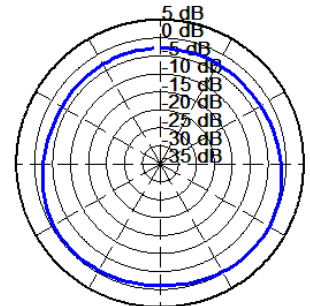
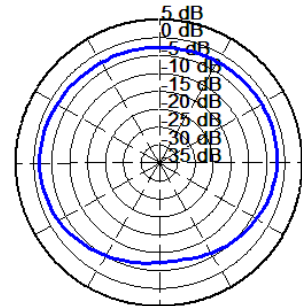
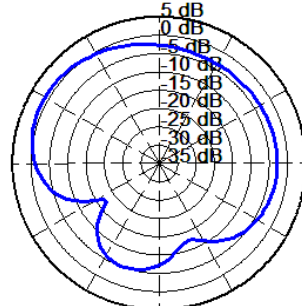
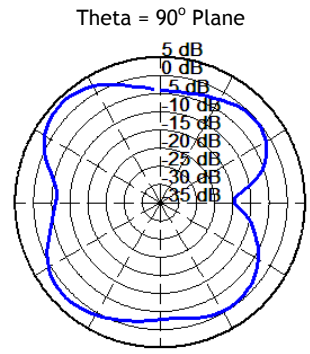
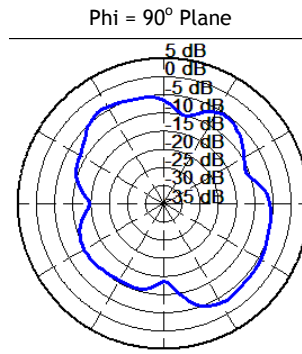
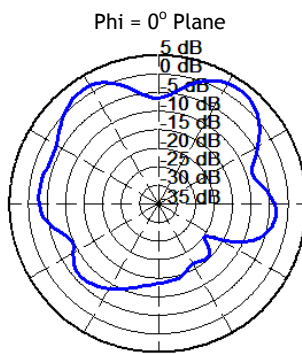

Looking for pricing, stock, or lifecycle information?

Click below to explore more details on WIN SOURCE:

 [View M830510 on WIN SOURCE](#)

 [Ethertronics/AVX Information](#)

Optimize Your Supply Chain with WIN SOURCE Solutions

-  Global Sourcing Solution
-  Obsolete Management
-  Cost Control Management
-  Shortage Management
-  Alternative Solution
-  Excess Inventory Management