



**THE DATASHEET OF  
TDF8530TH/N2,118**





## NXP quad-channel Class-D audio amplifier TDF8530TH

# Award-winning 4-channel Class-D amplifier for seamless audio in hybrid cars

Winner of the CEM Yearly Choice Award for “Most Competitive Automotive Electronics Product,” this ultra-efficient device supports 6 V stop-start applications and delivers audiophile sound quality.

### KEY FEATURES

- ▶ Outstanding sound performance confirmed by customer feedback
  - Harmonics
  - THD
  - Plop
  - Noise level
  - Frequency range
- ▶ Energy efficiency and start-stop support
  - Ultra-efficient 4-channel Class-D amplifier
    - Output power: 4 x 70 W
    - Supply voltage: 6 to 24 V
  - Uninterrupted sound experience in cars with start-stop systems
  - Low operating voltage: down to 6 V
- ▶ Protection and diagnostics for automotive robustness
  - Thermal fold-back in hardware for optimal sound under maximum power conditions
  - Protection against slamming a door or the trunk lid

- Full range of diagnostics increases quality, reduces yield loss, and lowers screening costs
- ▶ AEC-Q100 ensuring automotive quality
- ▶ Small HSOP44 package (SOT1131-1)

### ADVANCED CLOCKING FOR EMC ROBUSTNESS:

- ▶ Switchable oscillator clock source: internal for Master mode or external for Slave mode
- ▶ Spread spectrum mode
- ▶ Phase staggering
- ▶ Frequency hopping

### APPLICATIONS

- ▶ Automotive head-unit radio
- ▶ Automotive sound systems



NXP's highly integrated, high-performance Class-D amplifiers for automotive applications bring concert-quality sound to in-car entertainment systems.

The TDF8530, one of the latest additions to NXP's portfolio, is an ultra-efficient, quad-channel Class-D audio amplifier that supports the 6 V requirement for start-stop vehicles. It enables a rich, seamless audio experience in hybrid electric vehicles, micro-hybrids, mild hybrids, and other energy-saving vehicles that use start-stop systems.

The TDF8530 is optimized for use in the head-unit radio and in sound-system platforms. It also supports new applications, such as ambient sound systems, which generate engine sounds in electric vehicles, and active noise-cancellation systems.

The TDF8530 is an ultra-efficient device, generating 70 W per channel at the maximum supply voltage of 24 V. It delivers optimal sound under maximum power conditions, offers outstanding EMC performance, and uses a thermal fold-back, integrated in hardware, to protect the device from overheating.

A full range of diagnostics and protections ensure full robustness in the harsh automotive environment. Controlled by the I<sup>2</sup>C bus, the diagnostics cover familiar functions such as speaker protection, clip detection, and AC load tweeter detection, and also include unique features for start-up functions.

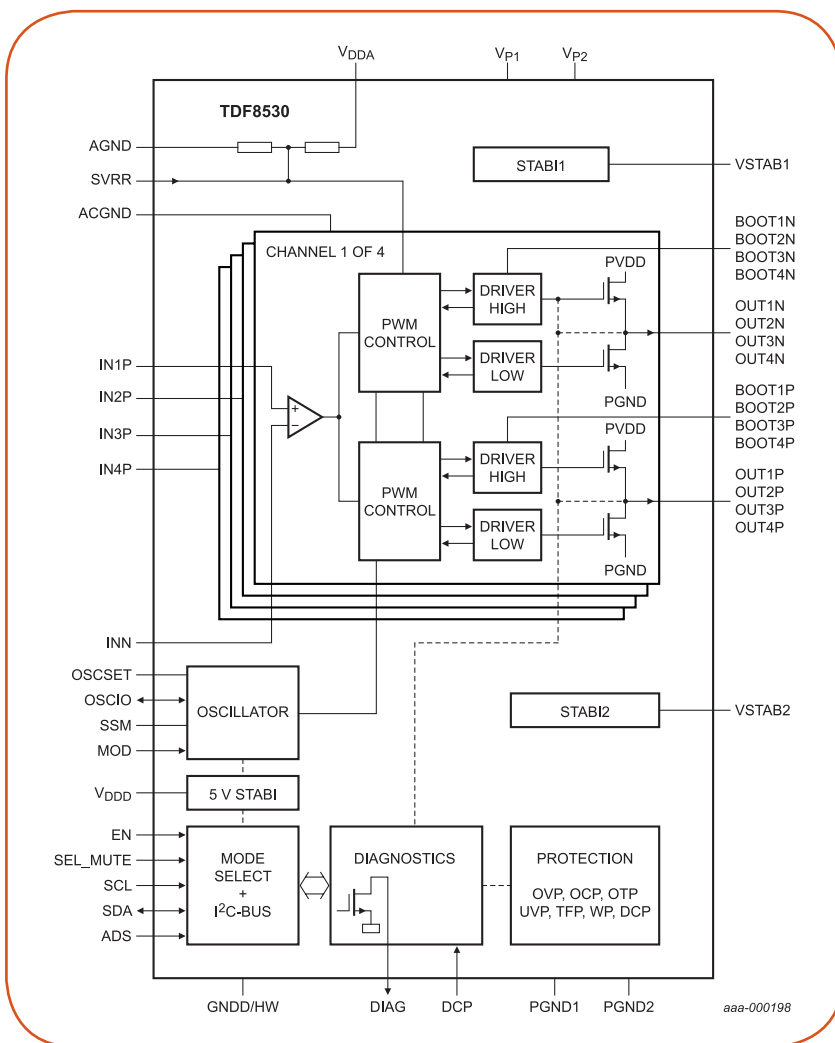

**Block diagram**

[www.nxp.com](http://www.nxp.com)

© 2013 NXP Semiconductors N.V.

All rights reserved. Reproduction in whole or in part is prohibited without the prior written consent of the copyright owner. The information presented in this document does not form part of any quotation or contract, is believed to be accurate and reliable and may be changed without notice. No liability will be accepted by the publisher for any consequence of its use. Publication thereof does not convey nor imply any license under patent- or other industrial or intellectual property rights.

Date of release: April 2013

Document order number: 9397 750 17410

Printed in the Netherlands

## Looking for pricing, stock, or lifecycle information?

Click below to explore more details on WIN SOURCE:

- ⊖ [View TDF8530TH/N2,118 on WIN SOURCE](#)
- ⊖ [NXP / Nexperia Information](#)

## Optimize Your Supply Chain with WIN SOURCE Solutions

- ✓ Global Sourcing Solution
- ✓ Obsolete Management
- ✓ Cost Control Management
- ✓ Shortage Management
- ✓ Alternative Solution
- ✓ Excess Inventory Management