



**THE DATASHEET OF
IS62WV5128EBLL-45TLI**



IS62WV5128EALL/EBLL/ECLL IS65WV5128EBLL/ECLL

512Kx8 LOW VOLTAGE, ULTRA LOW POWER CMOS STATIC RAM

APRIL 2017

KEY FEATURES

- High-speed access time: 35ns, 45ns, 55ns
- CMOS low power operation
 - Operating Current: 22 mA (max) at 85°C
 - CMOS Standby Current: 3.7uA (typ) at 25°C
- TTL compatible interface levels
- Single power supply
 - 1.65V-2.2V V_{DD} (IS62/65WV5128EALL)
 - 2.2V-3.6V V_{DD} (IS62/65WV5128EBLL)
 - 3.3V +/-5% V_{DD} (IS62/65WV5128ECLL)
- Three state outputs
- Industrial and Automotive temperature support
- Lead-free available

DESCRIPTION

The *ISSI* IS62/65WV5128EALL/BLL/CLL are high-speed, 4M bit static RAMs organized as 512K words by 8 bits. It is fabricated using *ISSI*'s high-performance CMOS technology. This highly reliable process coupled with innovative circuit design techniques, yields high-performance and low power consumption devices.

When CS# is HIGH (deselected), the device assumes a standby mode at which the power dissipation can be reduced down with CMOS input levels.

Easy memory expansion is provided by using Chip Enable and Output Enable inputs. The active LOW Write Enable (WE#) controls both writing and reading of the memory.

The IS62/65WV5128EALL/EBLL are packaged in the JEDEC standard 32-pin TSOP (TYPE I/II), sTSOP (TYPE I), SOP and 36-pin mini BGA.

FUNCTIONAL BLOCK DIAGRAM

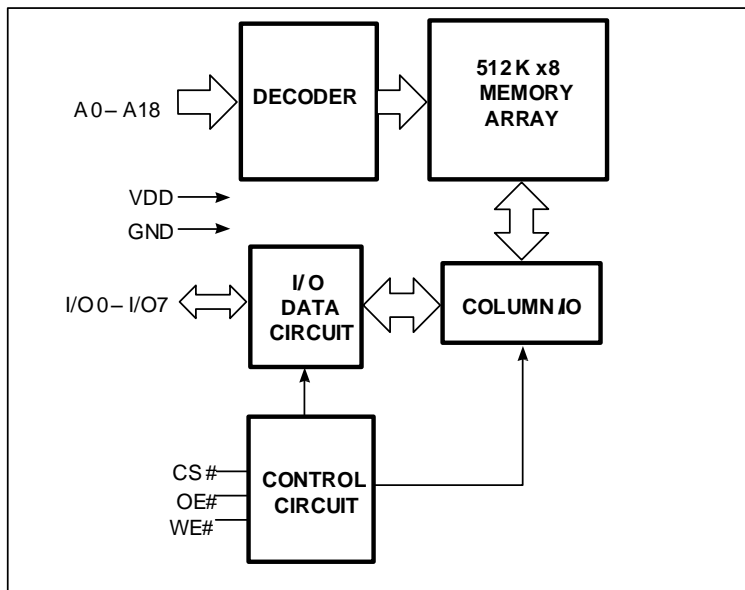

Copyright © 2017 Integrated Silicon Solution, Inc. All rights reserved. ISSI reserves the right to make changes to this specification and its products at any time without notice. ISSI assumes no liability arising out of the application or use of any information, products or services described herein. Customers are advised to obtain the latest version of this device specification before relying on any published information and before placing orders for products.

Integrated Silicon Solution, Inc. does not recommend the use of any of its products in life support applications where the failure or malfunction of the product can reasonably be expected to cause failure of the life support system or to significantly affect its safety or effectiveness. Products are not authorized for use in such applications unless Integrated Silicon Solution, Inc. receives written assurance to its satisfaction, that:

- a.) the risk of injury or damage has been minimized;
- b.) the user assume all such risks; and
- c.) potential liability of Integrated Silicon Solution, Inc is adequately protected under the circumstances

IS62WV5128EALL/EBLL/ECLL
IS65WV5128EBLL/ECLL

PIN CONFIGURATIONS

36-Pin mini BGA (6mm x 8mm)

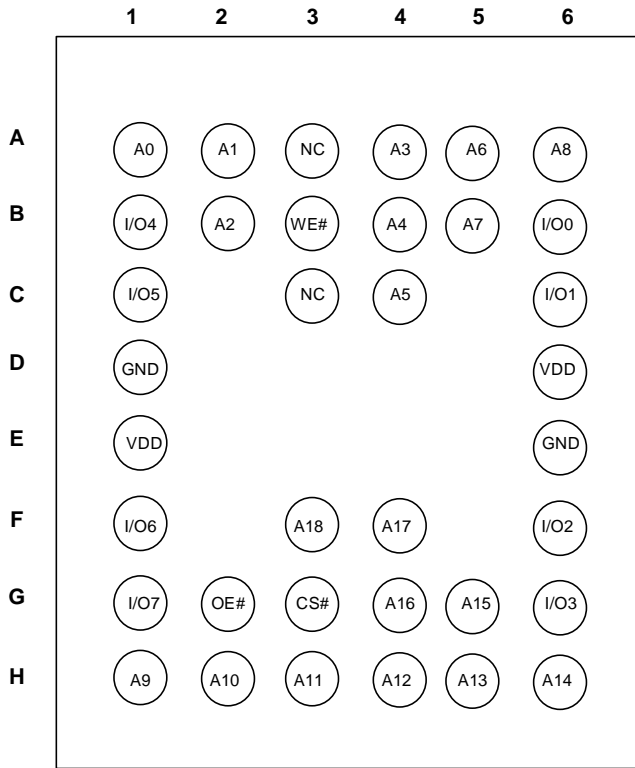

32-Pin TSOP (Type I)
32-Pin STSOP (Type I)

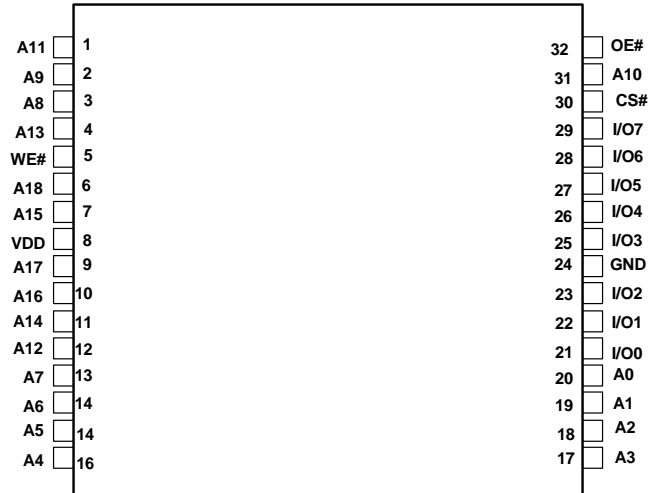

32-Pin SOP
32-Pin TSOP (Type II)

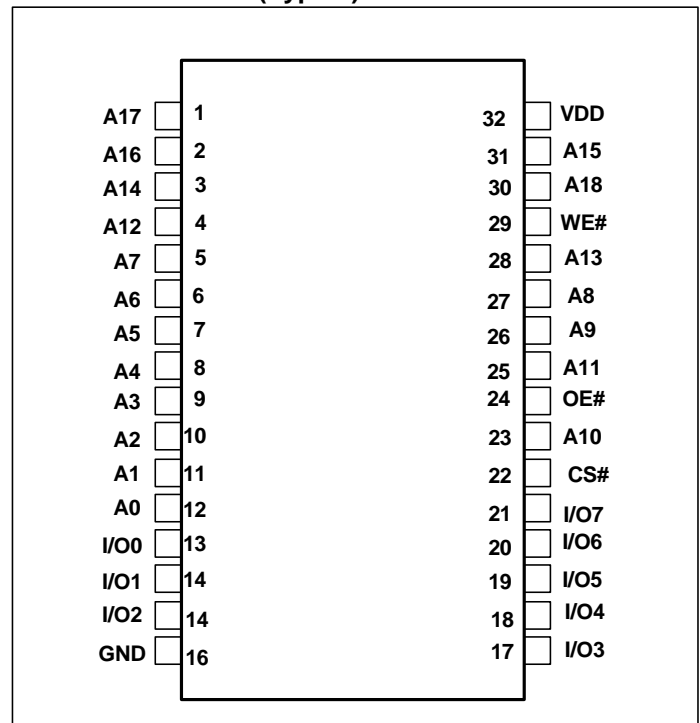

PIN DESCRIPTIONS

A0-A18	Address Inputs
I/O0-I/O7	Data Inputs/Outputs
CS#	Chip Enable Input
OE#	Output Enable Input
WE#	Write Enable Input
NC	No Connection
VDD	Power
GND	Ground

IS62WV5128EALL/EBLL/ECLL IS65WV5128EBLL/ECLL

FUNCTION DESCRIPTION

SRAM is one of random access memories. SRAM has three different modes supported. Each function is described below with Truth Table.

STANDBY MODE

Device enters standby mode when deselected (CS# HIGH). The input and output pins (I/O0-7) are placed in a high impedance state. CMOS input in this mode will maximize saving power.

WRITE MODE

Write operation issues with Chip selected (CS# LOW) and Write Enable (WE#) input LOW. The input and output pins (I/O0-7) are in data input mode. Output buffers are closed during this time even if OE# is LOW.

READ MODE

Read operation issues with Chip selected (CS# LOW) and Write Enable (WE#) input HIGH. When OE# is LOW, output buffer turns on to make data output. Any input to I/O pins during READ mode is not permitted.

In the READ mode, output buffers can be turned off by pulling OE# HIGH. In this mode, internal device operates as READ but I/Os are in a high impedance state. Since device is in READ mode, active current is used.

TRUTH TABLE

Mode	CS#	WE#	OE#	I/O0-I/O7	VDD Current
Not Selected	H	X	X	High-Z	ISB2
Output Disabled	L	H	H	High-Z	ICC,ICC1
Write	L	L	X	DIN	ICC,ICC1
Read	L	H	L	DOUT	ICC,ICC1

IS62WV5128EALL/EBLL/ECLL
IS65WV5128EBLL/ECLL
ABSOLUTE MAXIMUM RATINGS AND OPERATING RANGE
ABSOLUTE MAXIMUM RATINGS⁽¹⁾

Symbol	Parameter	Value	Unit
V _{term}	Terminal Voltage with Respect to GND	-0.5 to V _{DD} + 0.5	V
V _{DD}	V _{DD} Related to GND	-0.3 to 4.0	V
t _{Stg}	Storage Temperature	-65 to +150	°C
P _T	Power Dissipation	1.0	W

Notes:

1. Stress greater than those listed under ABSOLUTE MAXIMUM RATINGS may cause permanent damage to the device. This is a stress rating only and functional operation of the device at these or any other conditions above those indicated in the operational sections of this specification is not implied. Exposure to absolute maximum rating conditions for extended periods may affect reliability.

OPERATING RANGE⁽¹⁾

Range	Ambient Temperature	Part Number	SPEED (max)	VDD(min)	VDD(typ)	VDD(max)
Commercial	0°C to +70°C	~EALL	55 ns	1.65V	1.8V	2.2V
Industrial	-40°C to +85°C		55 ns	1.65V	1.8V	2.2V
Automotive	-40°C to +125°C		55 ns	1.65V	1.8V	2.2V
Commercial	0°C to +70°C	~EBLL	45ns	2.2V	3.0V	3.6V
Industrial	-40°C to +85°C		45ns	2.2V	3.0V	3.6V
Automotive	-40°C to +125°C		55ns	2.2V	3.0V	3.6V
Commercial	0°C to +70°C	~ECLL	35ns	3.135V	3.3V	3.465V
Industrial	-40°C to +85°C		35ns	3.135V	3.3V	3.465V
Automotive	-40°C to +125°C		45ns	3.135V	3.3V	3.465V

Note:

1. Full device AC operation assumes a 100 μs ramp time from 0 to V_{cc}(min) and 200 μs wait time after V_{cc} stabilization.

PIN CAPACITANCE⁽¹⁾

Parameter	Symbol	Test Condition	Max	Units
Input capacitance	C _{IN}	T _A = 25°C, f = 1 MHz, V _{DD} = V _{DD} (typ)	6	pF
DQ capacitance (IO0–IO7)	C _{I/O}		8	pF

Note:

1. These parameters are guaranteed by design and tested by a sample basis only.

THERMAL CHARACTERISTICS⁽¹⁾

Parameter	Symbol	Rating	Units
Thermal resistance from junction to ambient (airflow = 1m/s)	R _{θJA}	TBD	°C/W
Thermal resistance from junction to pins	R _{θJB}	TBD	°C/W
Thermal resistance from junction to case	R _{θJC}	TBD	°C/W

Note:

1. These parameters are guaranteed by design and tested by a sample basis only.

**IS62WV5128EALL/EBLL/ECLL
IS65WV5128EBLL/ECLL**
AC TEST CONDITIONS (OVER THE OPERATING RANGE)

Parameter	Unit (1.65V~2.2V)	Unit (2.2V~3.6V)	Unit (3.3V +/-5%)
Input Pulse Level	0V to V_{DD}	0V to V_{DD}	0V to V_{DD}
Input Rise and Fall Time	1V/ns	1V/ns	1V/ns
Output Timing Reference Level	0.9V	$\frac{1}{2} V_{DD}$	$\frac{1}{2} V_{DD} + 0.05V$
R1	13500	1005	1213
R2	10800	820	1378
V_{TM}	1.8V	V_{DD}	V_{DD}
Output Load Conditions	Refer to Figure 1 and 2		

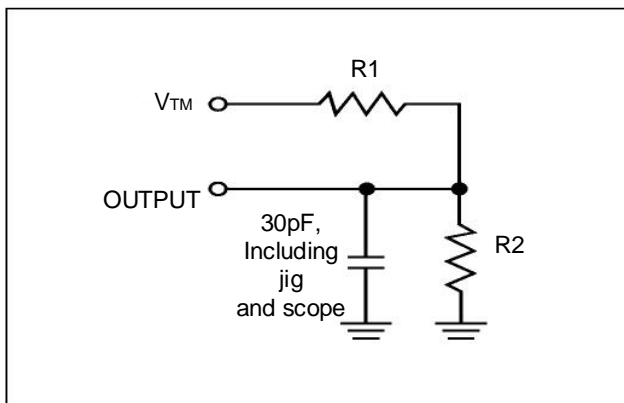
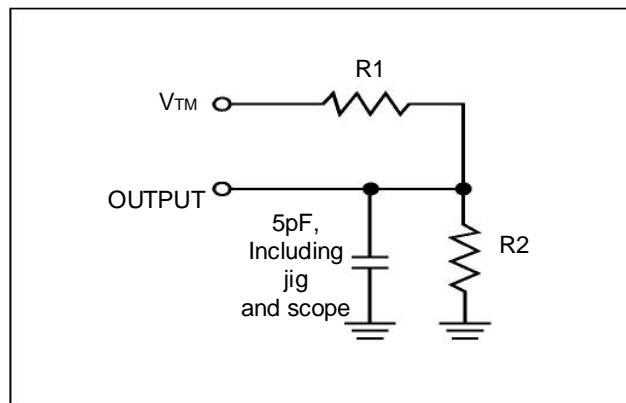
OUTPUT LOAD CONDITIONS FIGURES
FIGURE 1

FIGURE 2

IS62WV5128EALL/EBLL/ECLL
IS65WV5128EBLL/ECLL
DC ELECTRICAL CHARACTERISTICS
IS62(5)WV5128EALL DC ELECTRICAL CHARACTERISTICS- I (OVER THE OPERATING RANGE)
VDD = 1.65V ~ 2.2V

Symbol	Parameter	Test Conditions	Min	Max	Unit
V _{OH}	Output HIGH Voltage	I _{OH} = -0.1 mA	1.4	—	V
V _{OL}	Output LOW Voltage	I _{OL} = 0.1 mA	—	0.2	V
V _{IH} ⁽¹⁾	Input HIGH Voltage		1.4	V _{DD} + 0.2	V
V _{IL} ⁽¹⁾	Input LOW Voltage		-0.2	0.4	V
I _{LI}	Input Leakage	GND < V _{IN} < V _{DD}	-1	1	μA
I _{LO}	Output Leakage	GND < V _{IN} < V _{DD} , Output Disabled	-1	1	μA

Notes:

- V_{ILL}(min) = -1.0V AC (pulse width < 10ns). Not 100% tested.
V_{IIH}(max) = V_{DD} + 1.0V AC (pulse width < 10ns). Not 100% tested.

IS62(5)WV5128EBLL DC ELECTRICAL CHARACTERISTICS- I (OVER THE OPERATING RANGE)
VDD = 2.2V ~ 3.6V

Symbol	Parameter	Test Conditions	Min	Max	Unit
V _{OH}	Output HIGH Voltage	2.2 ≤ V _{DD} < 2.7, I _{OH} = -0.1 mA	2.0	—	V
		2.7 ≤ V _{DD} ≤ 3.6, I _{OH} = -1.0 mA	2.4	—	V
V _{OL}	Output LOW Voltage	2.2 ≤ V _{DD} < 2.7, I _{OL} = 0.1 mA	—	0.4	V
		2.7 ≤ V _{DD} ≤ 3.6, I _{OL} = 2.1 mA	—	0.4	V
V _{IH} ⁽¹⁾	Input HIGH Voltage	2.2 ≤ V _{DD} < 2.7	1.8	V _{DD} + 0.3	V
		2.7 ≤ V _{DD} ≤ 3.6	2.0	V _{DD} + 0.3	V
V _{IL} ⁽¹⁾	Input LOW Voltage	2.2 ≤ V _{DD} < 2.7	-0.3	0.6	V
		2.7 ≤ V _{DD} ≤ 3.6	-0.3	0.8	V
I _{LI}	Input Leakage	GND < V _{IN} < V _{DD}	-1	1	μA
I _{LO}	Output Leakage	GND < V _{IN} < V _{DD} , Output Disabled	-1	1	μA

Notes:

- V_{ILL}(min) = -2.0V AC (pulse width < 10ns). Not 100% tested.
V_{IIH}(max) = V_{DD} + 2.0V AC (pulse width < 10ns). Not 100% tested.

IS62(5)WV5128ECLL DC ELECTRICAL CHARACTERISTICS - I (OVER THE OPERATING RANGE)
VDD = 3.3V +/-5%

Symbol	Parameter	Test Conditions	Min	Max	Unit
V _{OH}	Output HIGH Voltage	I _{OH} = -1.0 mA	2.4	—	V
V _{OL}	Output LOW Voltage	I _{OL} = 2.1 mA	—	0.4	V
V _{IH} ⁽¹⁾	Input HIGH Voltage		2.0	V _{DD} + 0.3	V
V _{IL} ⁽¹⁾	Input LOW Voltage		-0.3	0.8	V
I _{LI}	Input Leakage	GND < V _{IN} < V _{DD}	-1	1	μA
I _{LO}	Output Leakage	GND < V _{IN} < V _{DD} , Output Disabled	-1	1	μA

Notes:

- V_{ILL}(min) = -2.0V AC (pulse width < 10ns). Not 100% tested.
V_{IIH}(max) = V_{DD} + 2.0V AC (pulse width < 10ns). Not 100% tested.
- V_{DD}=3.3V +/-5% is for high speed of 35ns device (ECLL).

IS62WV5128EALL/EBLL/ECLL
IS65WV5128EBLL/ECLL
IS62(5)WV5128EALL DC ELECTRICAL CHARACTERISTICS-II FOR POWER
(OVER THE OPERATING RANGE)

Symbol	Parameter	Test Conditions	Grade	55ns		Unit	
				Typ ⁽¹⁾	Max		
ICC	V _{DD} Dynamic Operating Supply Current	V _{DD} = V _{DD(max)} , I _{OUT} = 0mA, f = f _{max} , CS# = V _{IL}	Com.	-	20	mA	
			Ind.	-	22		
			Auto. A3	-	22		
ICC1	V _{DD} Static Operating Supply Current	V _{DD} = V _{DD(max)} , I _{OUT} = 0mA, f = 0, CS# = V _{IL}	Com.	-	5	mA	
			Ind.	-	5		
			Auto. A3	-	5		
ISB2	CMOS Standby Current (CMOS Inputs)	V _{DD} = V _{DD(max)} , f = 0, CS# ≥ V _{DD} - 0.2V, VIN ≤ 0.2V or VIN ≥ V _{DD} - 0.2V	Com.	25°C	3.7	6	µA
				40°C	3.8	7	
				70°C	3.9	9	
			Ind.	85°C	4.1	10	
			Auto. A3	125°C	8.1	25	

Note:

1. Typical values are measured at V_{DD} = 1.8V, T_A = 25°C, and not 100% tested.

IS62(5)WV5128EBLL/ECLL DC ELECTRICAL CHARACTERISTICS-II FOR POWER
(OVER THE OPERATING RANGE)

Symbol	Parameter	Test Conditions	Grade	35ns ⁽¹⁾		45/55ns		Unit	
				Typ ⁽²⁾	Max	Typ ⁽²⁾	Max		
ICC	V _{DD} Dynamic Operating Supply Current	V _{DD} = V _{DD(max)} , I _{OUT} = 0mA, f = f _{max} , CS# = V _{IL}	Com.	-	22	-	20	mA	
			Ind.	-	25	-	22		
			Auto. A3	-	-	-	22		
ICC1	V _{DD} Static Operating Supply Current	V _{DD} = V _{DD(max)} , I _{OUT} = 0mA, f = 0, CS# = V _{IL}	Com.	-	5	-	5	mA	
			Ind.	-	5	-	5		
			Auto. A3	-	-	-	5		
ISB2	CMOS Standby Current (CMOS Inputs)	V _{DD} = V _{DD(max)} , f = 0, CS# ≥ V _{DD} - 0.2V, VIN ≤ 0.2V or VIN ≥ V _{DD} - 0.2V	Com.	25°C	3.7	6	3.7	6	µA
				40°C	3.8	7	3.8	7	
				70°C	3.9	9	3.9	9	
			Ind.	85°C	4.1	10	4.1	10	
			Auto. A3	125°C	8.1	25	8.1	25	

Notes:

1. 35 ns speed bin is for ECLL (V_{DD}=3.3V +/-5%) only.
2. Typical values are measured at V_{DD} = 3.0V, and not 100% tested.

IS62WV5128EALL/EBLL/ECLL
IS65WV5128EBLL/ECLL
AC CHARACTERISTICS⁽⁶⁾ (OVER OPERATING RANGE)
READ CYCLE AC CHARACTERISTICS

Parameter	Symbol	35ns ⁽⁷⁾		45ns		55ns		unit	notes
		Min	Max	Min	Max	Min	Max		
Read Cycle Time	tRC	35	-	45	-	55	-	ns	1,5
Address Access Time	tAA	-	35	-	45	-	55	ns	1
Output Hold Time	tOHA	8	-	10	-	10	-	ns	1
CS# Access Time	tACS	-	35	-	45	-	55	ns	1
OE# Access Time	tDOE	-	18	-	20	-	25	ns	1
OE# to High-Z Output	tHZOE	-	12	-	15	-	20	ns	2
OE# to Low-Z Output	tLZOE	4	-	5	-	5	-	ns	2
CS# to High-Z Output	tHZCS	-	12	-	15	-	20	ns	2
CS# to Low-Z Output	tLZCS	10	-	10	-	10	-	ns	2

WRITE CYCLE AC CHARACTERISTICS

Parameter	Symbol	35ns ⁽⁷⁾		45ns		55ns		unit	notes
		Min	Max	Min	Max	Min	Max		
Write Cycle Time	tWC	35	-	45	-	55	-	ns	1,3,5
CS# to Write End	tSCS	30	-	35	-	40	-	ns	1,3
Address Setup Time to Write End	tAW	30	-	35	-	40	-	ns	1,3
Address Hold from Write End	tHA	0	-	0	-	0	-	ns	1,3
Address Setup Time	tSA	0	-	0	-	0	-	ns	1,3
WE# Pulse Width	tPWE	30	-	35	-	40	-	ns	1,3,4
Data Setup to Write End	tSD	18	-	20	-	25	-	ns	1,3
Data Hold from Write End	tHD	0	-	0	-	0	-	ns	1,3
WE# LOW to High-Z Output	tHZWE	-	12	-	15	-	20	ns	2,3
WE# HIGH to Low-Z Output	tLZWE	4	-	5	-	5	-	ns	2,3

Notes:

1. Tested with the load in Figure 1.
2. Tested with the load in Figure 2. Transition is measured ± 500 mV from steady-state voltage. tHZOE, tHZCS, tHZB, and tHZWE transitions are measured when the output enters a high impedance state. Not 100% tested.
3. The internal write time is defined by the overlap of CS# = LOW, and WE# = LOW. All four conditions must be in valid states to initiate a Write, but any condition can go inactive to terminate the Write. The Data Input Setup and Hold timing are referenced to the rising or falling edge of the signal that terminates the write.
4. tPWE > tHZWE + tSD when OE# is LOW.
5. Address inputs must meet V_{IH} and V_{IL} SPEC during this period. Any glitch or unknown inputs are not permitted. Unknown input with standby mode is acceptable.
6. Data retention characteristics are defined later in DATA RETENTION CHARACTERISTICS.
7. 35 ns speed bin is at VDD=3.3V +/-5% .

IS62WV5128EALL/EBLL/ECLL
IS65WV5128EBLL/ECLL

TIMING DIAGRAM

READ CYCLE NO. 1⁽¹⁾ (ADDRESS CONTROLLED, CS# = OE# = LOW, WE# = HIGH)

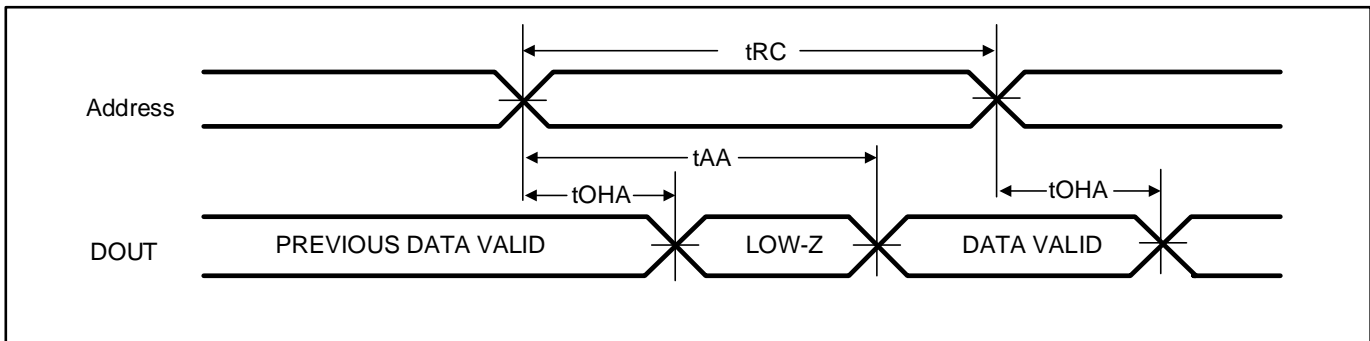

Note:

1. The device is continuously selected.

READ CYCLE NO. 2⁽¹⁾ (OE# CONTROLLED)

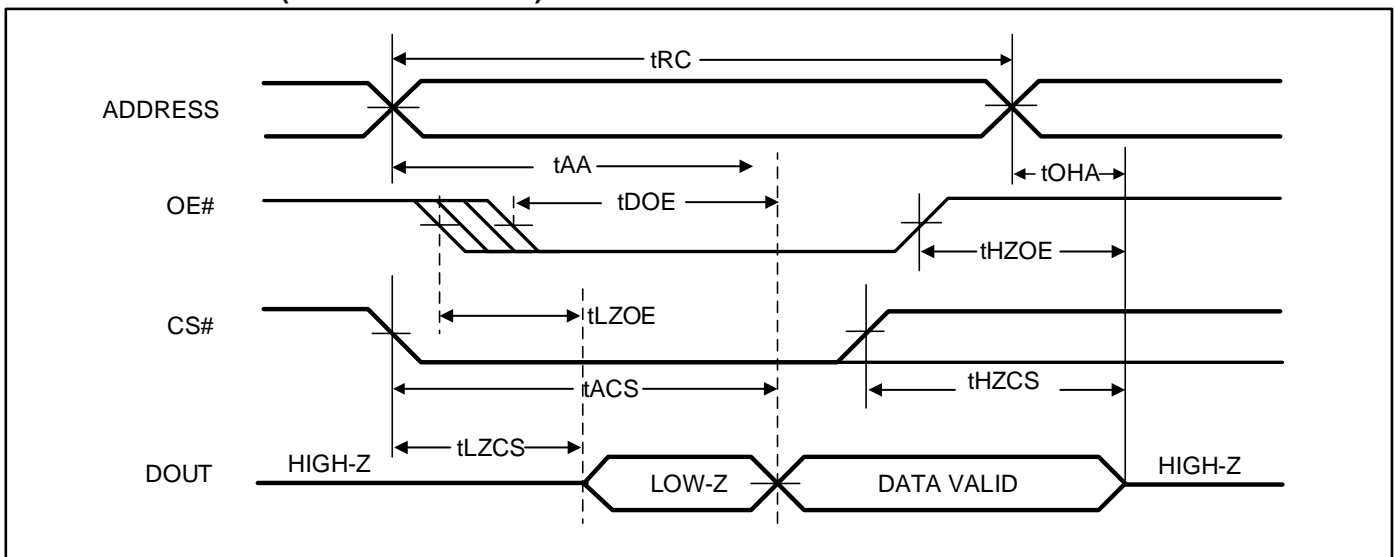

Note:

1. Address is valid prior to or coincident with CS# LOW transition.

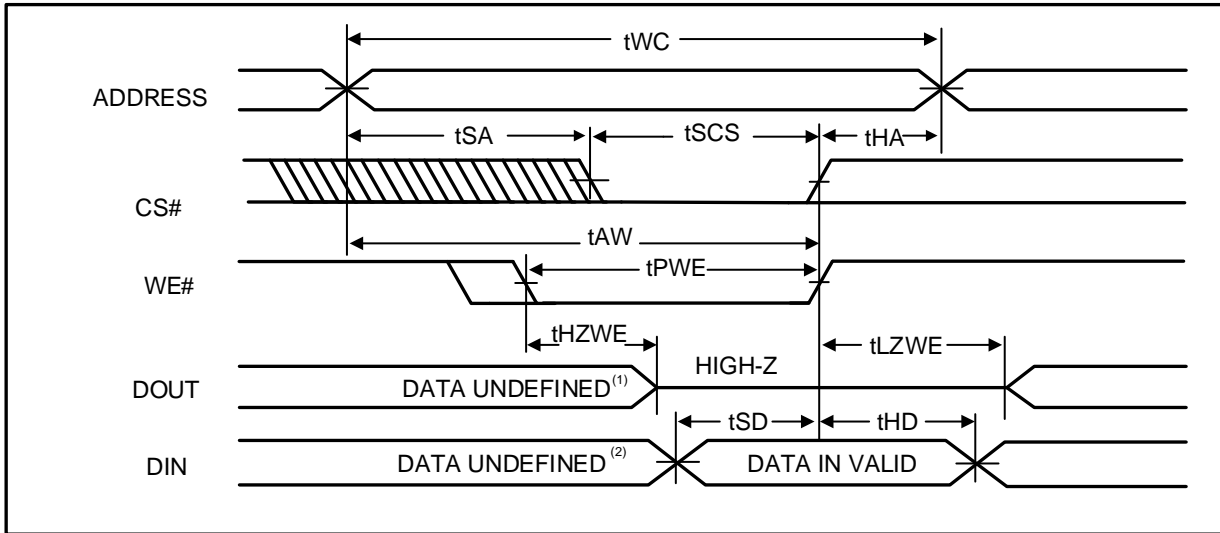
**IS62WV5128EALL/EBLL/ECLL
IS65WV5128EBLL/ECLL**
WRITE CYCLE NO. 1 ^(1,2) (CS# Controlled, OE# = HIGH or LOW)

Notes:

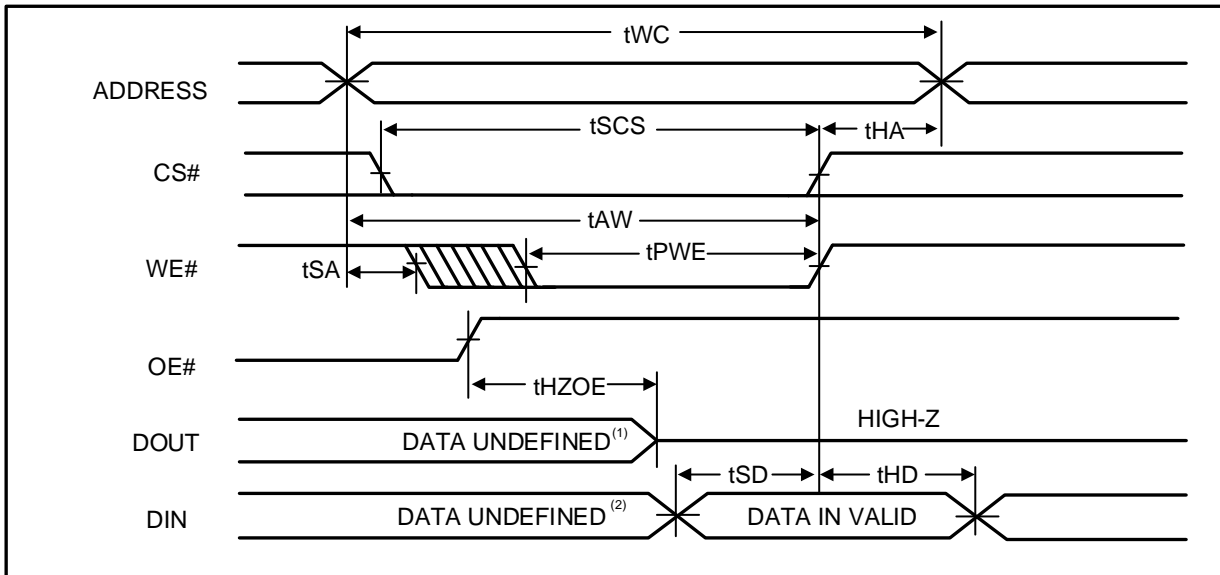
1. tHZWE is based on the assumption when tSA=0nS after READ operation. Actual DOUT for tHZWE may not appear if OE# goes high before Write Cycle. tHZOE is the time DOUT goes to High-Z after OE# goes high.
2. During this period the I/Os are in output state. Do not apply input signals.

WRITE CYCLE NO. 2 ^(1,2) (WE# CONTROLLED: OE# IS HIGH DURING WRITE CYCLE)

Notes:

1. tHZOE is the time DOUT goes to High-Z after OE# goes high.
2. During this period the I/Os are in output state. Do not apply input signals.

IS62WV5128EALL/EBLL/ECLL
IS65WV5128EBLL/ECLL

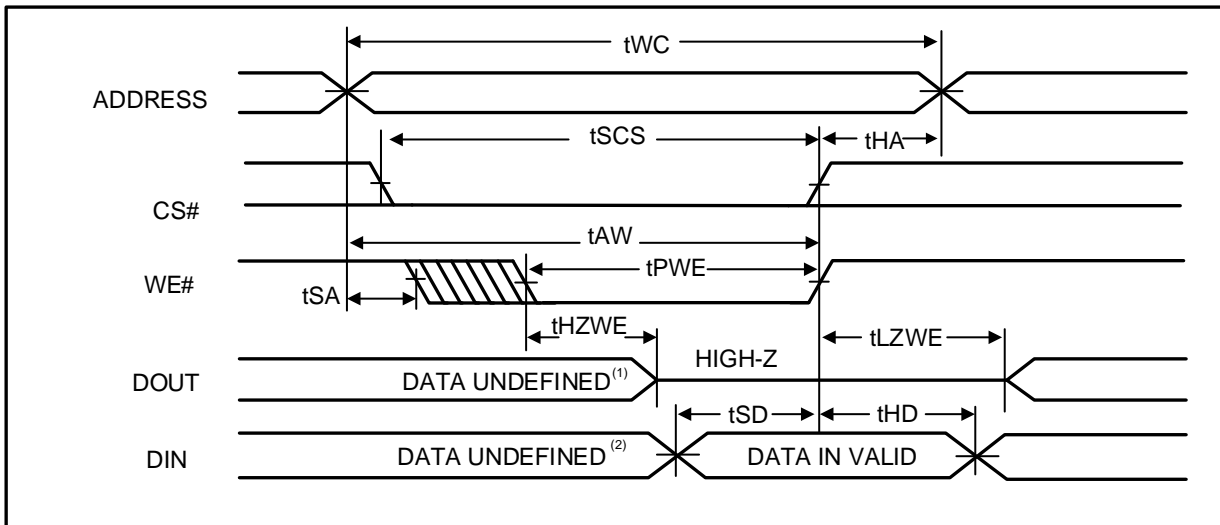
WRITE CYCLE NO. 3⁽¹⁾ (WE# CONTROLLED: OE# IS LOW DURING WRITE CYCLE)



Note:

1. If OE# is low during write cycle, tHZWE must be met in the application. Do not apply input signal during this period. Data output from the previous READ operation will drive IO BUS.

IS62WV5128EALL/EBLL/ECLL
IS65WV5128EBLL/ECLL
DATA RETENTION CHARACTERISTICS

Symbol	Parameter	Test Condition	OPTION	Min	Typ	Max	Unit
V_{DR}	V_{DD} for Data Retention	See Data Retention Waveform		1.5	-	3.6	V
I_{DR}	Data Retention Current	$V_{DD} = V_{DR}(\text{min})$, $CS\# \geq V_{DD} - 0.2V$ $V_{IN} \leq 0.2V$ or $V_{IN} \geq V_{DD} - 0.2V$	Com.	-	-	9	uA
			Ind.	-	-	10	
			Auto	-	-	25	
			typ. ⁽¹⁾	3.6			
t_{SDR}	Data Retention Setup Time	See Data Retention Waveform		0	-	-	ns
t_{RDR}	Recovery Time	See Data Retention Waveform		t_{RC}	-	-	ns

Note:

1. Typical values are measured at $V_{DD} = 1.8V$ or $3V$, $T_A = 25^\circ C$, and not 100% tested.
2. V_{DD} power down slope must be longer than 100 us/volt when enter into Data Retention Mode.

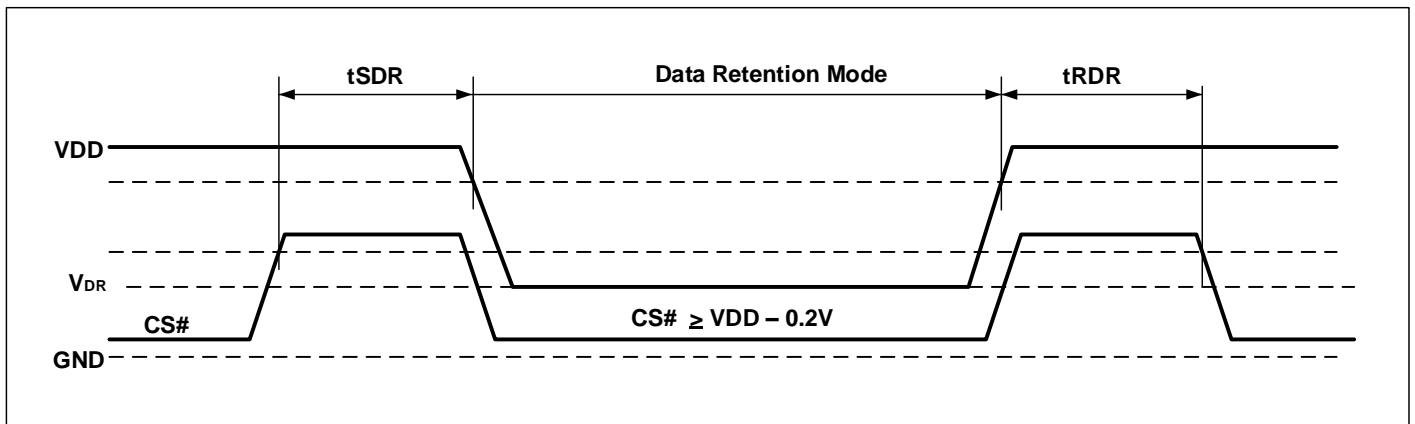
DATA RETENTION WAVEFORM (CS# CONTROLLED)

IS62WV5128EALL/EBLL/ECLL
IS65WV5128EBLL/ECLL
ORDERING INFORMATION
IS62WV5128EALL (1.65V - 2.2V)
Industrial Range: -40°C to +85°C

Speed (ns)	Order Part No.	Package
55	IS62WV5128EALL-55TLI	TSOP, Type I (8 x 20 mm), Lead-free
55	IS62WV5128EALL-55T2LI	TSOP, Type II, Lead-free
55	IS62WV5128EALL-55BI	mini BGA (6mm x 8mm)
55	IS62WV5128EALL-55BLI	mini BGA (6mm x 8mm), Lead-free
55	IS62WV5128EALL-55HLI	sTSOP (Type I), Lead-free (8 x 13.4 mm)

AUTOMOTIVE RANGE (A3): -40°C TO +125°C
**PLEASE CONTACT ISSI MARKETING*
IS62WV5128EBLL (2.2V – 3.6V)
Industrial Range: -40°C to +85°C

Speed (ns)	Order Part No.	Package
45	IS62WV5128EBLL-45TLI	TSOP, Type I (8 x 20 mm), Lead-free
45	IS62WV5128EBLL-45QLI	SOP, Lead-free
45	IS62WV5128EBLL-45T2LI	TSOP, Type II, Lead-free
45	IS62WV5128EBLL-45BI	mini BGA (6mm x 8mm)
45	IS62WV5128EBLL-45BLI	mini BGA (6mm x 8mm), Lead-free
45	IS62WV5128EBLL-45HLI	sTSOP (Type I), (8 x 13.4 mm), Lead-free

Automotive Range (A3): -40°C to +125°C

Speed (ns)	Order Part No.	Package
55	IS65WV5128EBLL-55CT2LA3	TSOP (Type II), Lead-free, Copper Lead-frame
55	IS65WV5128EBLL-55BLA3	mini BGA (6mm x 8mm), Lead-free

IS62WV5128EALL/EBLL/ECLL
IS65WV5128EBLL/ECLL
IS62WV5128ECLL (3.3V+/-5%)
Industrial Range: -40°C to +85°C

Speed (ns)	Order Part No.	Package
35	IS62WV5128ECLL-35TLI	TSOP, Type I (8 x 20 mm), Lead-free
35	IS62WV5128ECLL-35QLI	SOP, Lead-free
35	IS62WV5128ECLL-35T2LI	TSOP, Type II, Lead-free
35	IS62WV5128ECLL-35BI	mini BGA (6mm x 8mm)
35	IS62WV5128ECLL-35BLI	mini BGA (6mm x 8mm), Lead-free
35	IS62WV5128ECLL-35HLI	sTSOP (Type I), (8 x 13.4 mm), Lead-free

Automotive Range (A3): -40°C to +125°C

Speed (ns)	Order Part No.	Package
45	IS65WV5128ECLL-45CT2LA3	TSOP (Type II), Lead-free, Copper Lead-frame
45	IS65WV5128ECLL-45BLA3	mini BGA (6mm x 8mm), Lead-free

IS62WV5128EALL/EBLL/ECLL
IS65WV5128EBLL/ECLL

PACKAGE INFORMATION

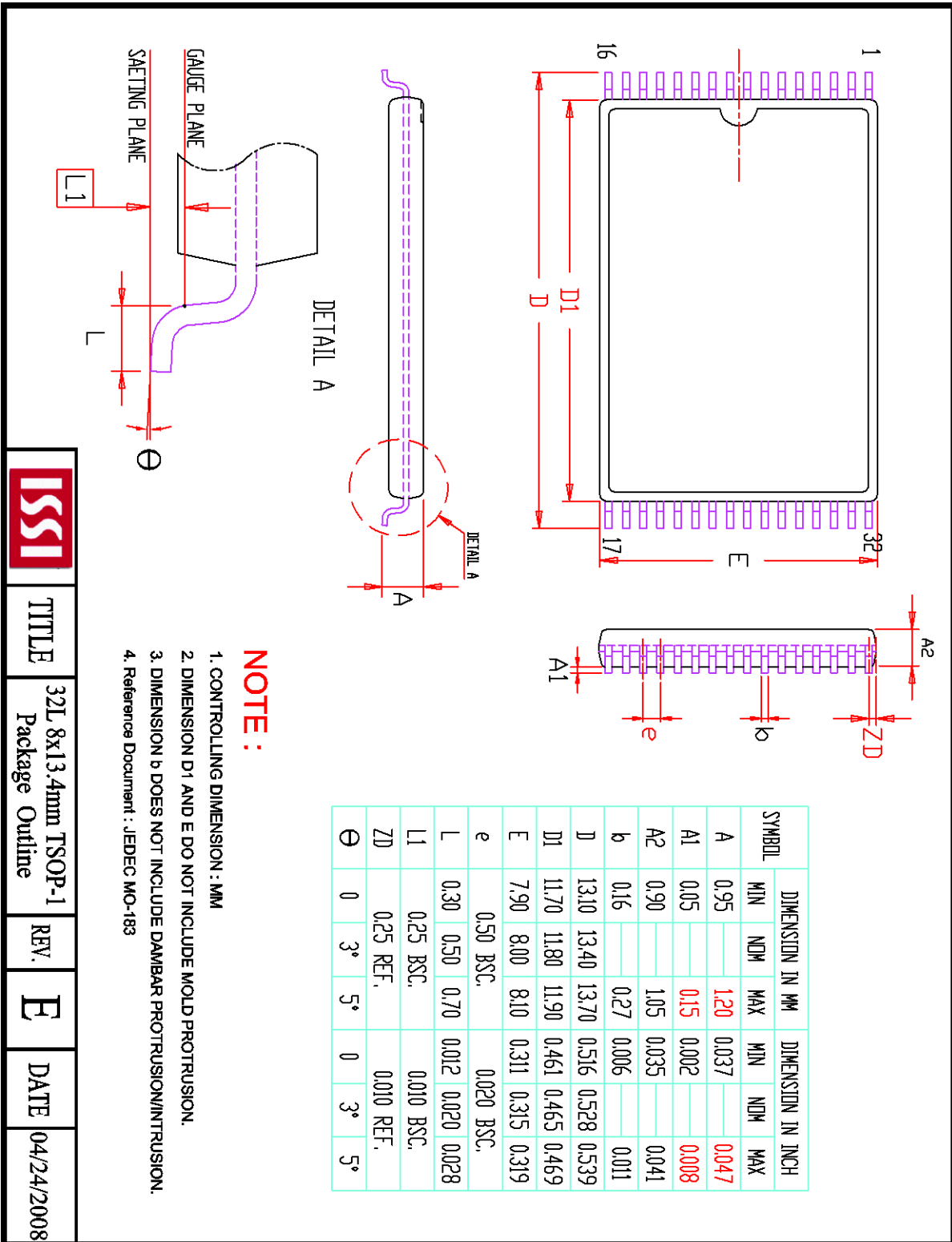

TITLE	32L 8x13.4mm TSOP-1 Package Outline	REV.	E	DATE	04/24/2008
-------	--	------	---	------	------------

IS62WV5128EALL/EBLL/ECLL
IS65WV5128EBLL/ECLL

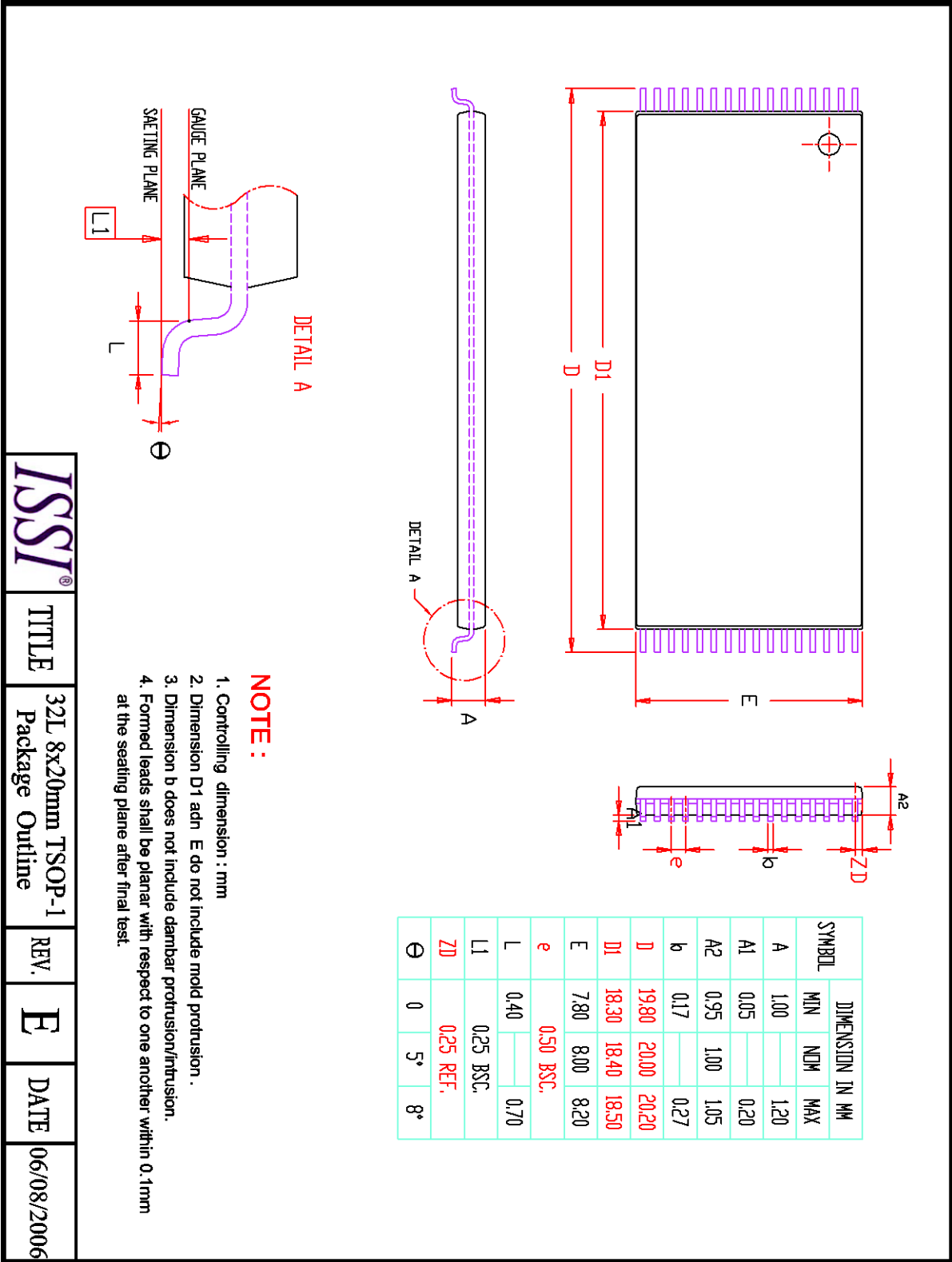

ISSI	TITLE	REV.	DATE
	32L 8x20mm TSOP-1 Package Outline	E	06/08/2006

IS62WV5128EALL/EBLL/ECLL
IS65WV5128EBLL/ECLL

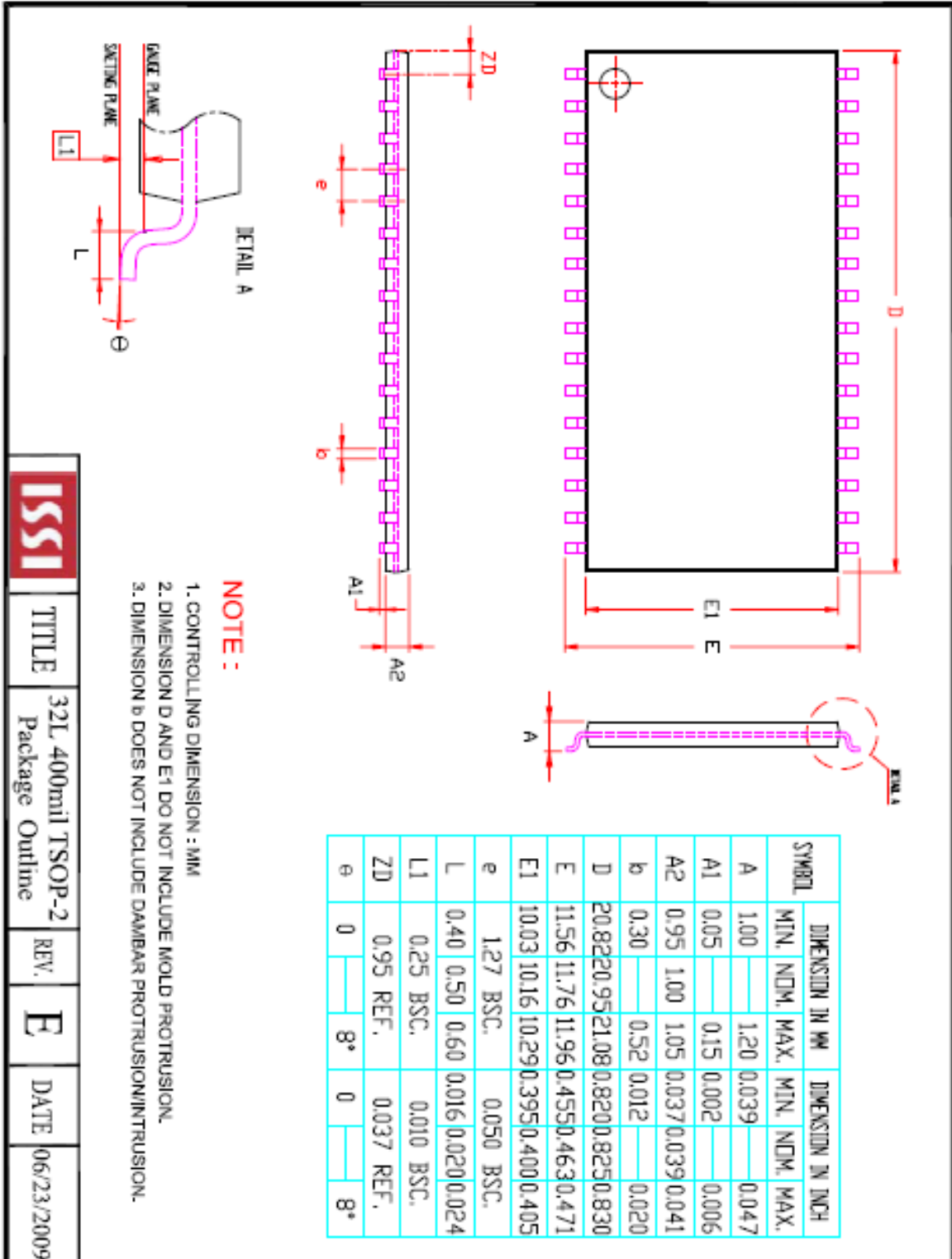

ISSI	TITLE	32L 400mil TSOP-2 Package Outline	REV.	E	DATE	06/23/2009
-------------	-------	--------------------------------------	------	----------	------	------------

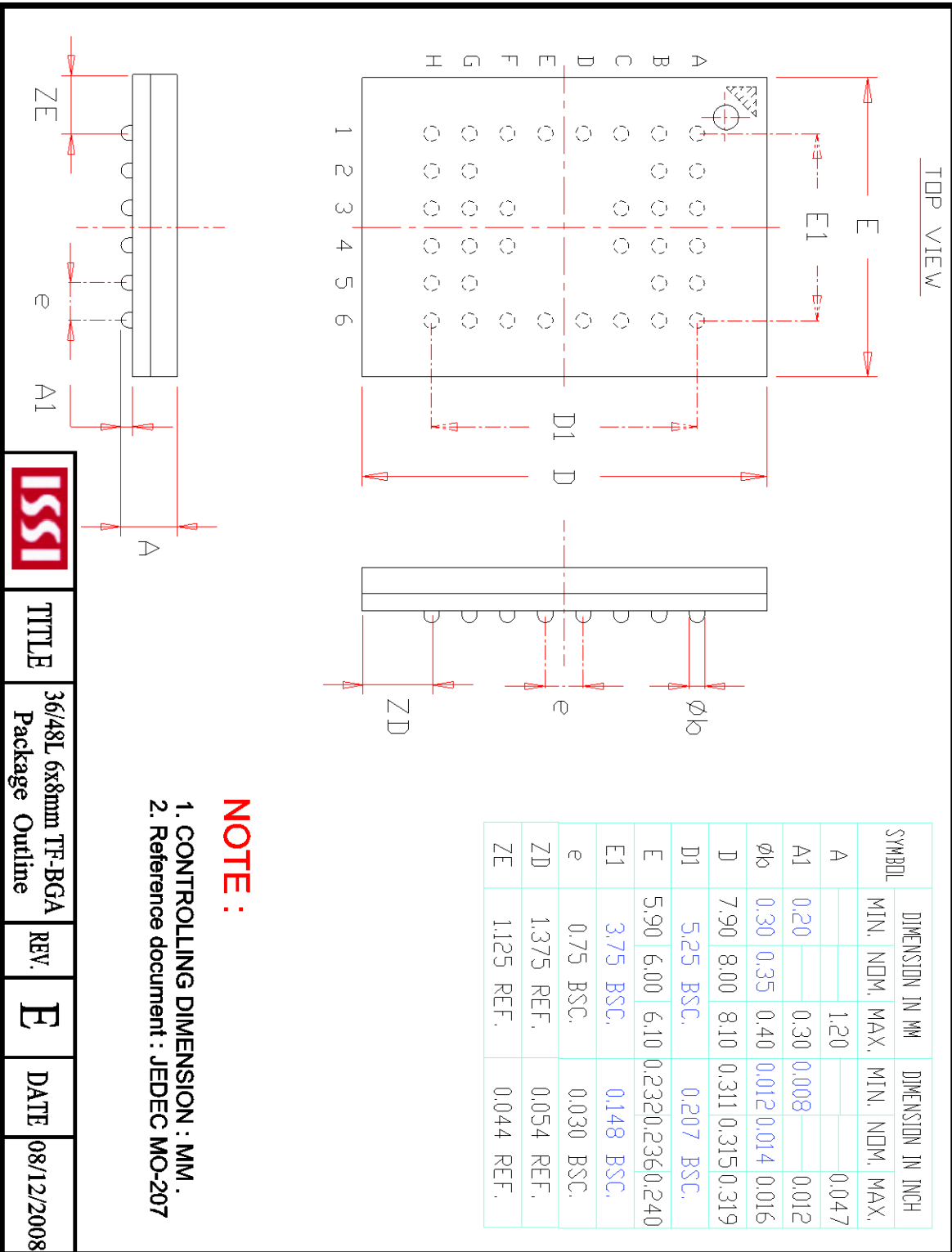

Looking for pricing, stock, or lifecycle information?

Click below to explore more details on WIN SOURCE:

- ⊖ [View IS62WV5128EBLL-45TLI on WIN SOURCE](#)
- ⊖ [ISSI, Integrated Silicon Solution Inc Information](#)

Optimize Your Supply Chain with WIN SOURCE Solutions

- ✓ Global Sourcing Solution
- ✓ Obsolete Management
- ✓ Cost Control Management
- ✓ Shortage Management
- ✓ Alternative Solution
- ✓ Excess Inventory Management