



**THE DATASHEET OF
ALP22A223DD040**



Overview

The KEMET ALP22 and ALT22/23 capacitors feature low ESR and high frequency impedance. The ALP/T22/23 capacitors have a very high CV per unit volume.

Applications

The ALP solder pin and ALT solder tag range details are incorporated herein, primarily, for maintenance and/or replacement purposes.

Benefits

- Solder tag (ALT) and DIN standard solder pin (ALP)
- Long life, up to 26,000 hours at +85°C (V_R, I_R applied)
- ALC snap-in should be considered for new designs



Part Number System

ALP	22A	682	AB	010	
Series	Version	Capacitance Code (μF)	Size Code	Rated Voltage (VDC)	
ALP = Solder pin ALT = Solder tag	22A = Standard 23A = Threaded Mounting Stud (ALT only)	First two digits represent significant figures. Third digit specifies number of zeros.	See Dimension Table	040 = 40 063 = 63 100 = 100 200 = 200	250 = 250 385 = 385 400 = 400 450 = 450

Performance Characteristics

Item	Performance Characteristics	
Capacitance Range	22 – 150,000 μ F	
Rated Voltage	40 – 450 VDC	
Operating Temperature	-40 to +85°C	
Storage Temperature Range	-55 to +85°C	
Capacitance Tolerance	\pm 20% at 100 Hz/+20°C	
Operational Lifetime	D (mm)	Rated Voltage and Ripple Current at +85°C (hours)
	25	12,000
	30	15,000
	35	18,000
	40	26,000
End of Life Requirement	Δ C/C < \pm 10%	
Shelf Life	2,000 hours at +85°C or 30,000 hours at +40°C 0 VDC	
Leakage Current	I = 0.006 CV or 6,000 μ A (whichever is smaller)	
	C = rated capacitance (μ F), V = rated voltage (VDC). Voltage applied for 5 minutes at +20°C.	
Standards	IEC 60384-4	

Surge Voltage

Condition	Voltage (VDC)				
	40	63	100	200	385
\leq 30 second surge, 1,000 cycles at +85°C	46	72.5	115	230	423.5

Test Method & Performance

Endurance Life Test		
Conditions	Performance	
Temperature	+85°C	
Test Duration	5,000 hours	
Ripple Current	Available upon request	
Voltage	The sum of DC voltage and the peak AC voltage must not exceed the rated voltage of the capacitor	
Performance	The following specifications will be satisfied when the capacitor is tested at +20°C:	
Capacitance Change	≤ 100 V	Within 15% of the initial value
	> 100 V	Within 10% of the initial value
Equivalent Series Resistance	Does not exceed 200% of the initial value	
Leakage Current	Does not exceed leakage current limit	

Dimensions – Millimeters (ALP)

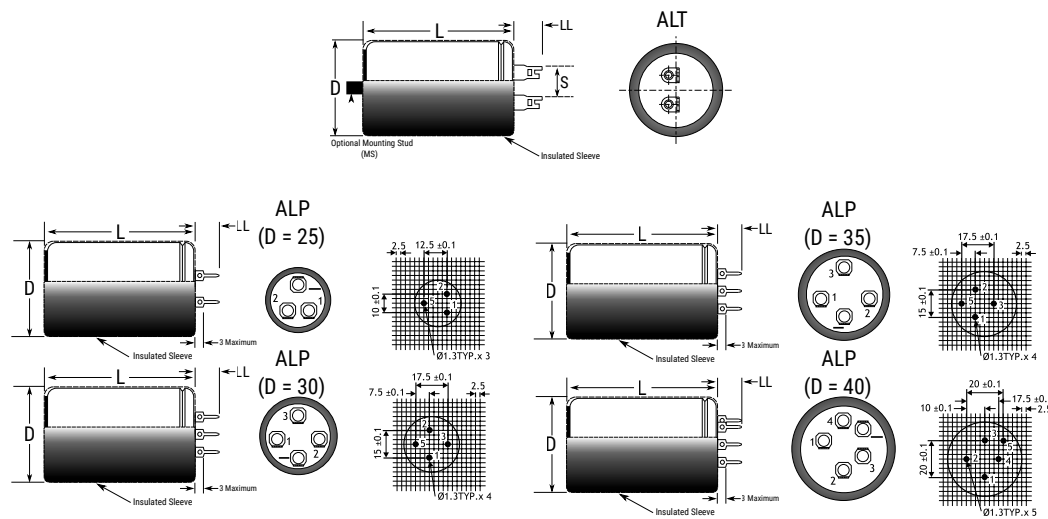

Size Code	Dimensions in mm			Approximate Weight Grams
	D	L	LL	
	±1	±2	±0.5	
AB	25	45	7.5	30
BB	30	45	7.5	50
CB	35	45	7.5	65
CD	35	55	7.5	75
DB	40	45	7.5	80
DD	40	55	7.5	95
DE	40	75	7.5	125
DF	40	105	7.5	170

Note: Dimensions include sleeving

Dimensions – Millimeters (ALT)

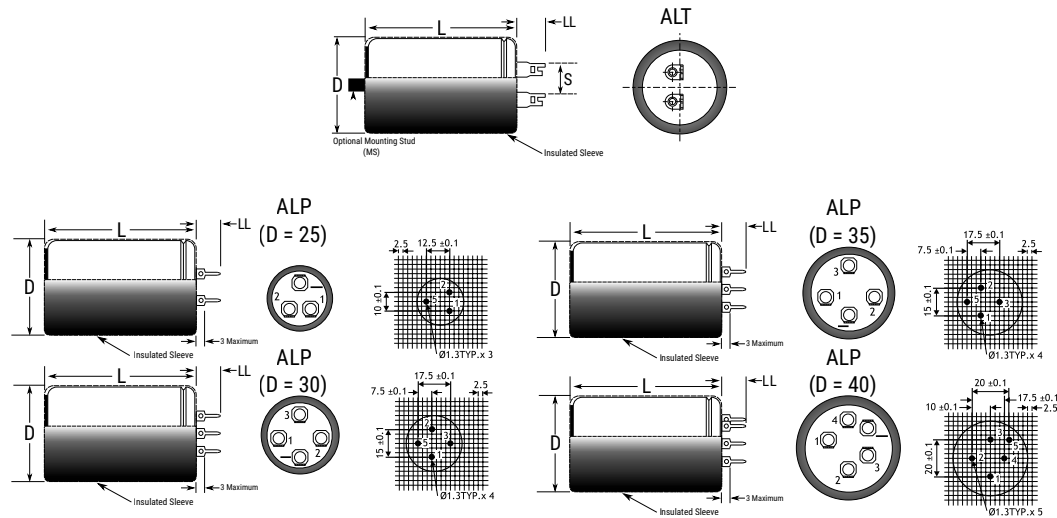

Size Code	Dimensions in mm				Mounting Stud (M x H)	Mounting Clip	Approximate Weight Grams
	D	L	S	LL			
	±1	±2	±0.5	±1			
AA	25	35	10	10	M8 x 12	V2/H1	30
AB	25	45	10	10	M8 x 12	V2/H1	39
BB	30	45	10	10	M8 x 12		50
CB	35	45	10	10	M8 x 12	V3/H2	65
CD	35	55	10	10	M8 x 12	V3/H2	75
DB	40	45	10	10	M8 x 12	V9	80
DD	40	55	10	10	M8 x 12	V9	95
DE	40	75	10	10	M8 x 12	V9	125
DF	40	105	10	10	M8 x 12	V9	170

Note: Dimensions include sleeving

Shelf Life

The capacitance, ESR and impedance of a capacitor will not change significantly after extended storage periods, however the leakage current will very slowly increase. KEMET products are particularly stable and allow a shelf life in excess of three years at 40°C. See sectional specification under each product series for specific data.

Re-age (Reforming) Procedure

Apply the rated voltage to the capacitor at room temperature for a period of one hour, or until the leakage current has fallen to a steady value below the specified limit. During re-aging a maximum charging current of twice the specified leakage current or 5 mA (whichever is greater) is suggested.

Reliability

The reliability of a component can be defined as the probability that it will perform satisfactorily under a given set of conditions for a given length of time.

In practice, it is impossible to predict with absolute certainty how any individual component will perform; thus, we must utilize probability theory. It is also necessary to clearly define the level of stress involved (e.g. operating voltage, ripple current, temperature and time). Finally, the meaning of satisfactory performance must be defined by specifying a set of conditions which determine the end of life of the component.

Reliability as a function of time, $R(t)$, is normally expressed as: $R(t) = e^{-\lambda t}$

where $R(t)$ is the probability that the component will perform satisfactorily for time t , and λ is the failure rate.

Failure Rate

The failure rate is the number of components failing per unit time. The failure rate of most electronic components follows the characteristic pattern:

- Early failures are removed during the manufacturing process.
- The operational life is characterized by a constant failure rate.
- The wear out period is characterized by a rapidly increasing failure rate.

The failures in time (FIT) are given with a 60% confidence level for the various type codes. By convention, FIT is expressed as 1×10^{-9} failures per hour. Failure rate is also expressed as a percentage of failures per 1,000 hours.

e.g., 100 FIT = 1×10^{-7} failures per hour = 0.01%/1,000 hours

End of Life Definition

Catastrophic Failure: short circuit, open circuit or safety vent operation

Parametric Failure:

- Change in capacitance $> \pm 10\%$
- Leakage current $>$ specified limit
- ESR $> 2 \times$ initial ESR value

MTBF

The mean time between failures (MTBF) is simply the inverse of the failure rate.

$$\text{MTBF} = 1/\lambda$$

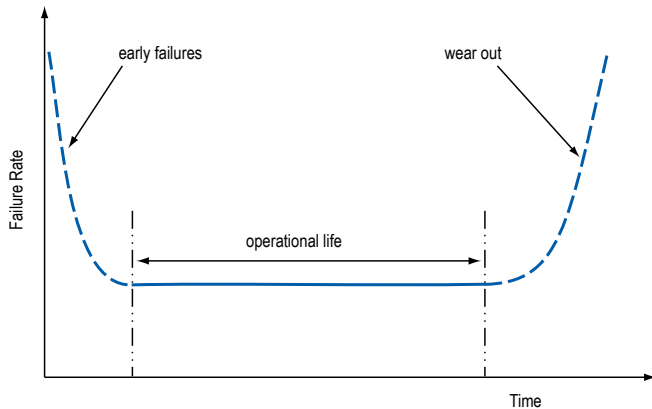

Environmental Compliance

As an environmentally conscious company, KEMET is working continuously with improvements concerning the environmental effects of both our capacitors and their production. In Europe (RoHS Directive) and in some other geographical areas like China, legislation has been put in place to prevent the use of some hazardous materials, such as lead (Pb), in electronic equipment. All products in this catalog are produced to help our customers' obligations to guarantee their products and fulfill these legislative requirements. The only material of concern in our products has been lead (Pb), which has been removed from all designs to fulfill the requirement of containing less than 0.1% of lead in any homogeneous material. KEMET will closely follow any changes in legislation world wide and makes any necessary changes in its products, whenever needed.

Some customer segments such as medical, military and automotive electronics may still require the use of lead in electrode coatings. To clarify the situation and distinguish products from each other, a special symbol is used on the packaging labels for RoHS compatible capacitors.

Because of customer requirements, there may appear additional markings such as LF = Lead Free or LFW = Lead Free Wires on the label.

NOT FOR NEW DESIGN

Pin/Solder Tag – ALP22 and ALT22/23 Series, +85°C

Table 1A – Ratings & Part Number Reference (ALP)

VDC	Rated Capacitance (μF)	Capacitance Tolerance	Size Code	Case Size	Part Number
40	4,700	20%	AB	25 x 45	ALP22A472AB040
40	6,800	20%	BB	30 x 45	ALP22A682BB040
40	10,000	20%	CB	35 x 45	ALP22A103CB040
40	15,000	20%	CD	35 x 55	ALP22A153CD040
40	22,000	20%	DD	40 x 55	ALP22A223DD040
63	2,700	20%	AB	25 x 45	ALP22A272AB063
63	4,700	20%	BB	30 x 45	ALP22A472BB063
63	10,000	20%	CD	35 x 55	ALP22A103CD063
63	10,000	20%	DD	40 x 55	ALP22A103DD063
63	15,000	20%	DE	40 x 75	ALP22A153DE063
100	1,000	20%	AB	25 x 45	ALP22A102AB100
100	4,700	20%	DD	40 x 55	ALP22A472DD100
100	10,000	20%	DF	40 x 105	ALP22A103DF100
200	220	20%	AB	25 x 45	ALP22A221AB200
200	680	20%	CD	35 x 55	ALP22A681CD200
200	680	20%	DB	40 x 45	ALP22A681DB200
200	1,000	20%	DD	40 x 55	ALP22A102DD200
200	2,200	20%	DF	40 x 105	ALP22A222DF200
385	220	20%	CB	35 x 45	ALP22A221CB385
385	470	20%	DD	40 x 55	ALP22A471DD385
385	680	20%	DE	40 x 75	ALP22A681DE385
385	1,000	20%	DF	40 x 105	ALP22A102DF385
450	100	20%	BB	30 x 45	ALP22A101BB450
450	220	20%	CD	35 x 55	ALP22A221CD450
450	470	20%	DE	40 x 75	ALP22A471DE450
450	680	20%	DF	40 x 105	ALP22A681DF450
450	820	20%	DF	40 x 105	ALP22A821DF450
450	1,000	20%	DE	40 x 75	ALP22A102DE450
VDC	Rated Capacitance (μF)	Capacitance Tolerance	Size Code	Case Size	Part Number

Table 1B – Ratings & Part Number Reference (ALT)

VDC	Rated Capacitance (μF)	Capacitance Tolerance	Size Code	Case Size	Part Number
40	4,700	20%	AB	25 x 45	ALT22A472AB040
40	10,000	20%	CB	35 x 45	ALT22A103CB040
40	15,000	20%	CD	35 x 55	ALT22A153CD040
40	22,000	20%	DD	40 x 55	ALT22A223DD040
63	4,700	20%	BB	30 x 45	ALT22A472BB063
63	10,000	20%	CD	35 x 55	ALT22A103CD063
63	15,000	20%	DE	40 x 75	ALT22A153DE063
100	1,000	20%	AB	25 x 45	ALT22A102AB100
100	4,700	20%	DD	40 x 55	ALT22A472DD100
100	10,000	20%	DF	40 x 105	ALT22A103DF100
200	220	20%	AB	25 x 45	ALT22A221AB200
200	680	20%	DB	40 x 45	ALT22A681DB200
200	1,000	20%	DD	40 x 55	ALT22A102DD200
200	2,200	20%	DF	40 x 105	ALT22A222DF200
385	100	20%	AB	25 x 45	ALT22A101AB385
385	150	20%	BB	30 x 45	ALT22A151BB385
385	470	20%	DD	40 x 55	ALT22A471DD385
385	1,000	20%	DF	40 x 105	ALT22A102DF385
VDC	Rated Capacitance (μF)	Capacitance Tolerance	Size Code	Case Size	Part Number

Print Detail

- KEMET Logo
- Rated capacitance
- Capacitance tolerance
- Rated voltage
- Climatic Category
- Date of manufacture and Batch No.
- Article code

Construction Data

The manufacturing process begins with the anode foil being electrochemically etched to increase the surface area and then “formed” to produce the aluminum oxide layer. Both the anode and cathode foils are then interleaved with absorbent paper and wound into a cylinder. During the winding process, aluminum tabs are attached to each foil to provide the electrical contact.

The deck, complete with terminals, is attached to the tabs and then folded down to rest on top of the winding. The complete winding is impregnated with electrolyte before being housed in a suitable container, usually an aluminum can, and sealed. Throughout the process, all materials inside the housing must be maintained at the highest purity and be compatible with the electrolyte.

Each capacitor is aged and tested before being sleeved and packed. The purpose of aging is to repair any damage in the oxide layer and thus reduce the leakage current to a very low level. Aging is normally carried out at the rated temperature of the capacitor and is accomplished by applying voltage to the device while carefully controlling the supply current. The process may take several hours to complete.

Damage to the oxide layer can occur due to variety of reasons:

- Slitting of the anode foil after forming
- Attaching the tabs to the anode foil
- Minor mechanical damage caused during winding

A sample from each batch is taken by the quality department after completion of the production process.

The following tests are applied and may be varied at the request of the customer. In this case the batch, or special procedure, will determine the course of action.

Electrical:

- Leakage current
- Capacitance
- ESR
- Impedance
- Tan Delta

Mechanical/Visual:

- Overall dimensions
- Torque test of mounting stud
- Print detail
- Box labels
- Packaging, including packed quantity

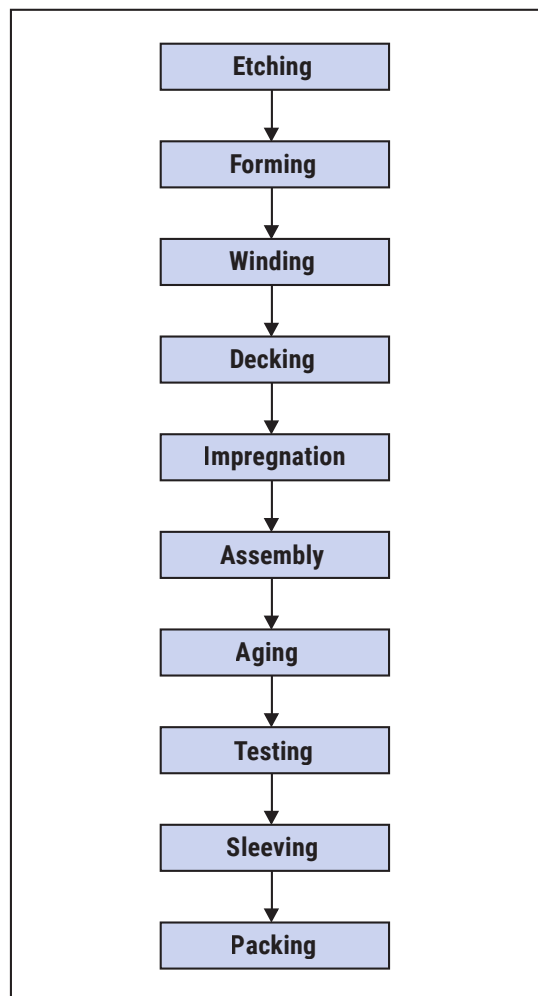
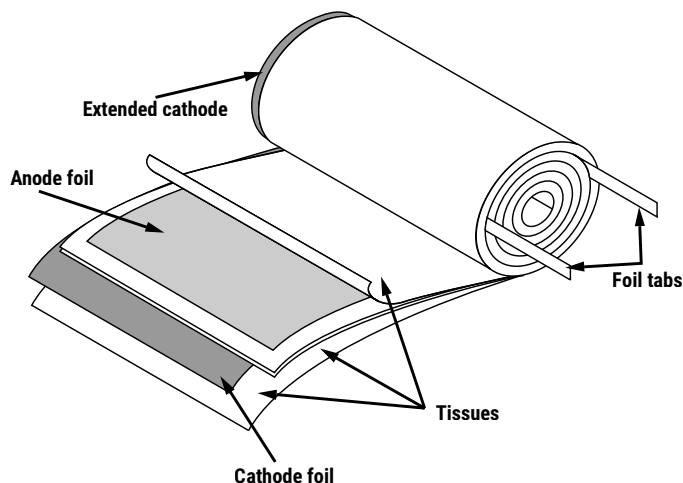

KEMET Electronics Corporation Sales Offices

For a complete list of our global sales offices, please visit www.kemet.com/sales.

Disclaimer

YAGEO Corporation and its affiliates do not recommend the use of commercial or automotive grade products for high reliability applications or manned space flight.

All product specifications, statements, information and data (collectively, the "Information") in this datasheet are subject to change. The customer is responsible for checking and verifying the extent to which the Information contained in this publication is applicable to an order at the time the order is placed. All Information given herein is believed to be accurate and reliable, but it is presented without guarantee, warranty, or responsibility of any kind, expressed or implied.

Statements of suitability for certain applications are based on KEMET Electronics Corporation's ("KEMET") knowledge of typical operating conditions for such applications, but are not intended to constitute – and KEMET specifically disclaims – any warranty concerning suitability for a specific customer application or use. The Information is intended for use only by customers who have the requisite experience and capability to determine the correct products for their application. Any technical advice inferred from this Information or otherwise provided by KEMET with reference to the use of KEMET's products is given gratis, and KEMET assumes no obligation or liability for the advice given or results obtained.

Although KEMET designs and manufactures its products to the most stringent quality and safety standards, given the current state of the art, isolated component failures may still occur. Accordingly, customer applications which require a high degree of reliability or safety should employ suitable designs or other safeguards (such as installation of protective circuitry or redundancies) in order to ensure that the failure of an electrical component does not result in a risk of personal injury or property damage.

Although all product-related warnings, cautions and notes must be observed, the customer should not assume that all safety measures are indicated or that other measures may not be required.

KEMET requires its products to be packaged and shipped on pallets. This is because KEMET's products are specifically designed to be packed onto pallets during shipment. If for any reason, the products are removed from pallets by the shipping party and shipped to the end customer, then additional external protection is required. In this instance, an external box with two carton layers and an upwards orientation sticker must be used by the shipping party, with the empty space filled with filling material, and afterwards sealing the box. If this packing and packaging guideline is not followed by the shipping party, the shipping party, and not KEMET, will be held responsible for any packaging, packing and/or product damages upon delivery of the products to the end customer. KEMET hereby disclaims any liability for damages to the products or otherwise that have been, or threaten to be, inflicted, result from or are in any way related to the packaging, packing or damage by the shipping party in contravention of the packing and packaging guidelines herein.

KEMET is a registered trademark of KEMET Electronics Corporation.

Looking for pricing, stock, or lifecycle information?

Click below to explore more details on WIN SOURCE:

 [View ALP22A223DD040 on WIN SOURCE](#)

 [Kemet Information](#)

Optimize Your Supply Chain with WIN SOURCE Solutions

-  Global Sourcing Solution
-  Obsolete Management
-  Cost Control Management
-  Shortage Management
-  Alternative Solution
-  Excess Inventory Management