



**THE DATASHEET OF  
RA81F0473STGNH#KB0**



### Description

The F0473 is an integrated dual-path RF front-end consisting of an RF switch and two gain stages with 6dB gain control used in the analog front-end receiver of an Active Antenna System (AAS). The F0473 supports frequencies from 3.3GHz to 4.2GHz.

The F0473 provides 35dB gain with +15dBm OP1dB, and 1.3dB noise figure (NF). Gain is reduced 6dB in a single step with a maximum settling time of 35ns. The device uses a single 3.3V supply and 130mA of I<sub>DD</sub>.

The F0473 is offered in a 5 × 5 × 0.8 mm, 32-pin package with 50Ω input and output amplifier impedances for ease of integration into the signal path.

### Typical Applications

- Multi-mode, Multi-carrier receivers
- 4.5G (LTE Advanced)
- 5G NR bands n77 and n78

### Features

- Gain
  - 35dB typical in High Gain Mode
  - 29dB typical in Low Gain Mode
- 1.3dB typical NF
- OP1dB
  - +15dBm typical in High Gain Mode
  - +14dBm typical in Low Gain Mode
- 50Ω single-ended input / output amplifier impedances
- I<sub>DD</sub> = 130mA
- Independent Standby Mode for power savings
- Supply voltage: +3.15V to +3.45V
- 5 × 5 mm, 32-VFQFPN package
- -40°C to +105°C exposed pad operating temperature range

### Block Diagram

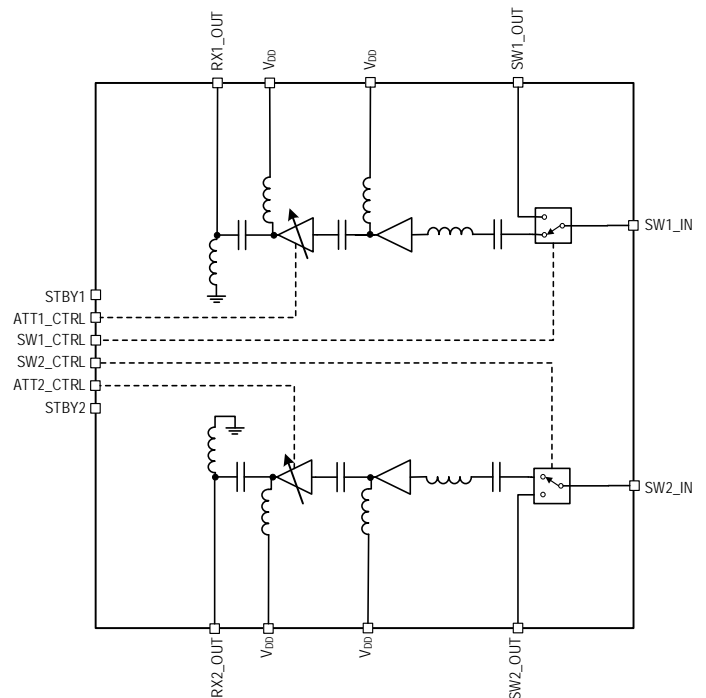

## Ordering Information

Orderable Part Number	Package	MSL Rating	Shipping Packaging	Temperature
RA81F0473STGNH#KB0	5 × 5 × 0.8 mm 32-VFQFPN	TBD	Tray	-40° to +105°C
RA81F0473STGNH#BB0	5 × 5 × 0.8 mm 32- VFQFPN	TBD	Reel	-40° to +105°C
RTKA81F0473ST000RU	Evaluation Board			

## Revision History

Revision Date	Description of Change
May 19, 2020	Initial release.

## IMPORTANT NOTICE AND DISCLAIMER

RENESAS ELECTRONICS CORPORATION AND ITS SUBSIDIARIES (“RENESAS”) PROVIDES TECHNICAL SPECIFICATIONS AND RELIABILITY DATA (INCLUDING DATASHEETS), DESIGN RESOURCES (INCLUDING REFERENCE DESIGNS), APPLICATION OR OTHER DESIGN ADVICE, WEB TOOLS, SAFETY INFORMATION, AND OTHER RESOURCES “AS IS” AND WITH ALL FAULTS, AND DISCLAIMS ALL WARRANTIES, EXPRESS OR IMPLIED, INCLUDING, WITHOUT LIMITATION, ANY IMPLIED WARRANTIES OF MERCHANTABILITY, FITNESS FOR A PARTICULAR PURPOSE, OR NON-INFRINGEMENT OF THIRD-PARTY INTELLECTUAL PROPERTY RIGHTS.

These resources are intended for developers who are designing with Renesas products. You are solely responsible for (1) selecting the appropriate products for your application, (2) designing, validating, and testing your application, and (3) ensuring your application meets applicable standards, and any other safety, security, or other requirements. These resources are subject to change without notice. Renesas grants you permission to use these resources only to develop an application that uses Renesas products. Other reproduction or use of these resources is strictly prohibited. No license is granted to any other Renesas intellectual property or to any third-party intellectual property. Renesas disclaims responsibility for, and you will fully indemnify Renesas and its representatives against, any claims, damages, costs, losses, or liabilities arising from your use of these resources. Renesas' products are provided only subject to Renesas' Terms and Conditions of Sale or other applicable terms agreed to in writing. No use of any Renesas resources expands or otherwise alters any applicable warranties or warranty disclaimers for these products.

(Disclaimer Rev.1.01 Jan 2024)

### Corporate Headquarters

TOYOSU FORESIA, 3-2-24 Toyosu,  
Koto-ku, Tokyo 135-0061, Japan  
[www.renesas.com](http://www.renesas.com)

### Trademarks

Renesas and the Renesas logo are trademarks of Renesas Electronics Corporation. All trademarks and registered trademarks are the property of their respective owners.

### Contact Information

For further information on a product, technology, the most up-to-date version of a document, or your nearest sales office, please visit [www.renesas.com/contact-us/](http://www.renesas.com/contact-us/).

## Looking for pricing, stock, or lifecycle information?

Click below to explore more details on WIN SOURCE:

- ⊖ [View RA81F0473STGNH#KB0 on WIN SOURCE](#)
- ⊖ [Renesas Electronics America](#) Information

## Optimize Your Supply Chain with WIN SOURCE Solutions

- ✓ Global Sourcing Solution
- ✓ Obsolete Management
- ✓ Cost Control Management
- ✓ Shortage Management
- ✓ Alternative Solution
- ✓ Excess Inventory Management